

NOTE:
REFER TO SECTIONS
ON SHEET 2 OF 2

SPLASH PAD (SEE G.102 AND
G.103) AND / OR PRETREATMENT
MEASURES AS SHOWN ON PLANS
BIORETENTION AREA, BIOSWALE,
OR VEGETATED SWALE (TYP.)

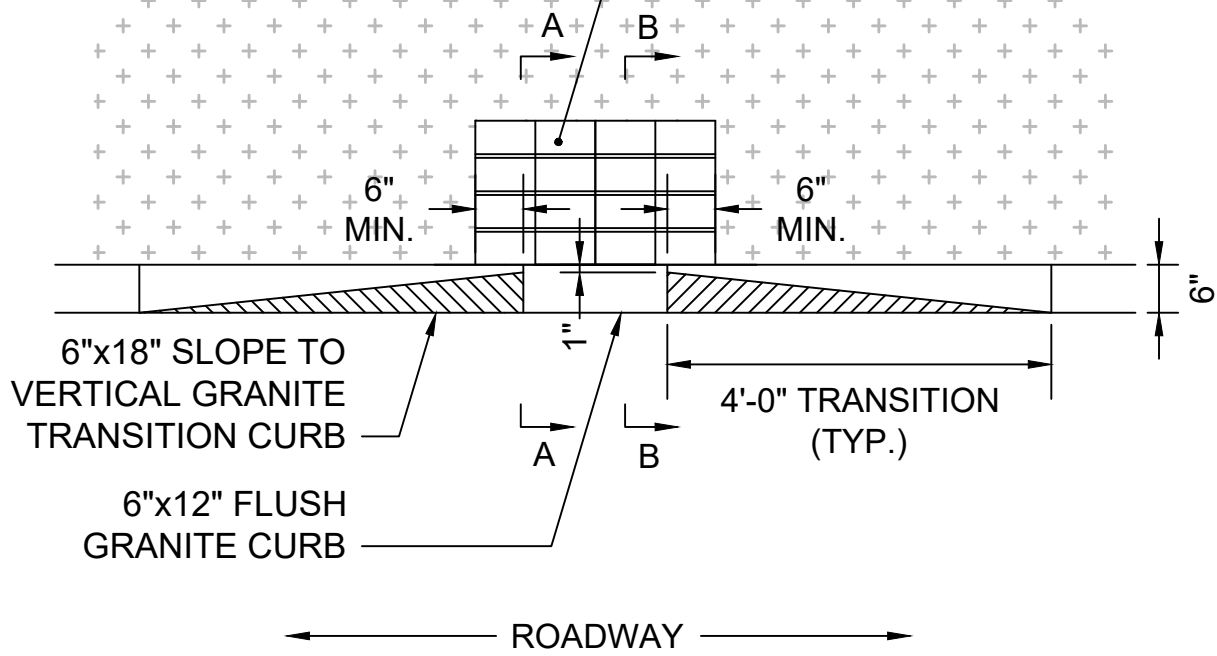

PLAN VIEW

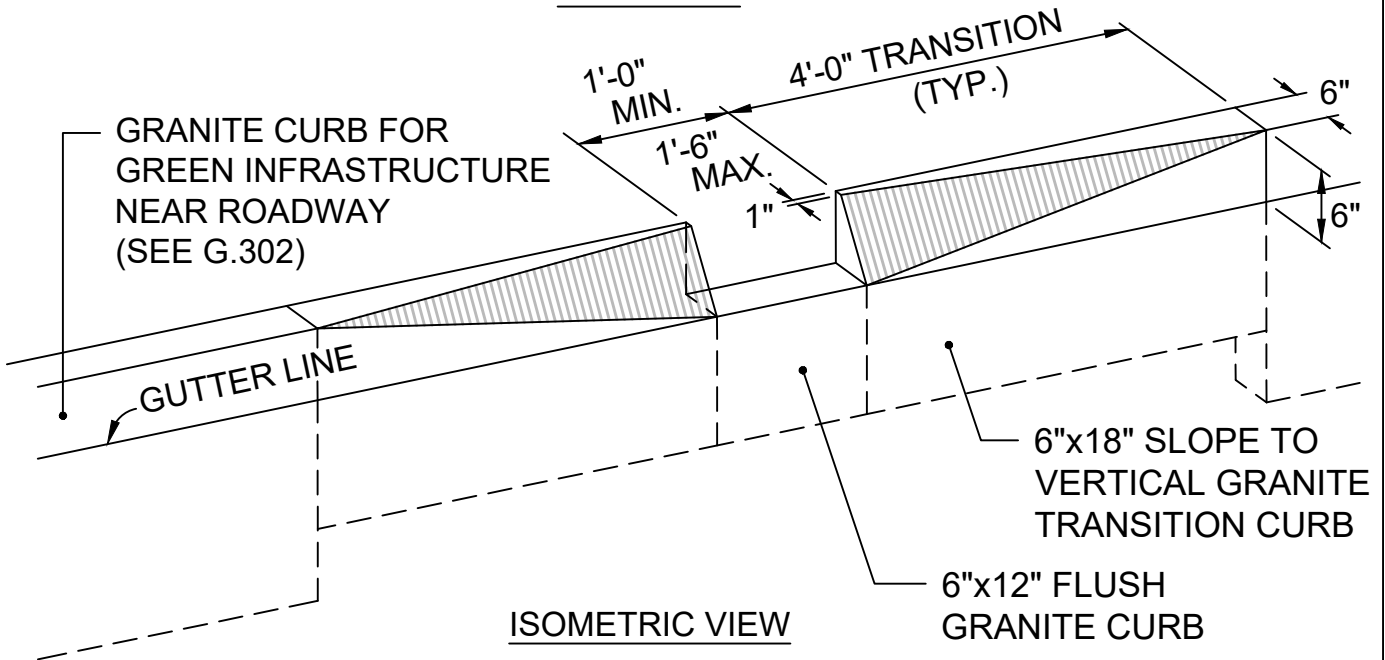

ISOMETRIC VIEW



**Public Works Department
Engineering Division**
1 CITY HALL SQUARE, ROOM 710
BOSTON, MA 02201
(617) 635-4968

**CURB CUT INLET
(1 OF 2)**

**DATE OF ISSUE:
DECEMBER 2024**

SCALE: N.T.S.

DETAIL NO.

G.101