



Martha Picket

Dress Boston

12/22/2023

dressboston

DRESS BOSTON

PROJECT 00529_DRESS BOSTON_EXTERIOR SIGNAGE - REV #4

SUBMISSION DATE

11/14/2023

REVISION DATE

11/30/2023 KW

12/04/2023 KW

12/13/2023 DD

12/21-2023 DD



BLUEBIRD
GRAPHIC SOLUTIONS

17 Everberg Road, Unit E
Woburn, MA 01801

info@bluebirdgs.com
617.250.8500



BLUEBIRD
GRAPHIC SOLUTIONS

17 Everberg Road, Unit E
Woburn, MA 01801

info@bluebirdgs.com
617.250.8500

CLIENT
DRESS BOSTON

ADDRESS
575 TREMONT ST
BOSTON, MA 02118

PROJECT
EXTERIOR SIGNAGE

JOB #
PROJ-00529

SUBMISSION DATE
11/14/2023

REVISION DATE
11/30/2023 KW
12/04/2023 KW
12/13/2023 DD
12/21/2023 DD



TYPICAL; NOT FOR PRODUCTION

01 FRONT VIEW
1 1/2" = 1'-0"

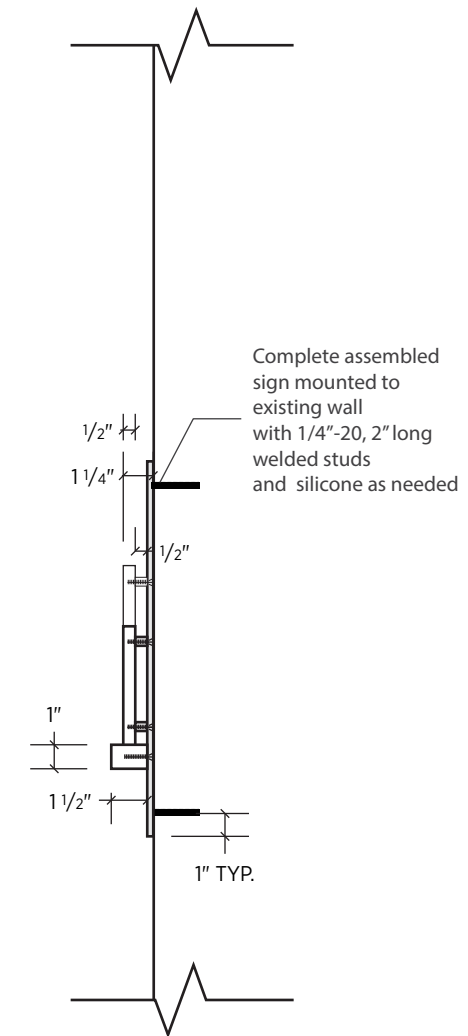

02 SIDE VIEW
1 1/2" = 1'-0"

SIGN TYPE A - MAIN ENTRY LOGO SIGN

Quantity (1)

PALETTE

- PAINT: TO MATCH 120 WHITE
- PAINT: TO MATCH 160 BLACK
- PAINT: TO MATCH GREY TBD

DESIGNER: K. WHITE, D.DUNCAN
PM: A. CLAYTON

SIGN TYPE	DRAWING
A	1.0



BLUEBIRD
GRAPHIC SOLUTIONS

17 Everberg Road, Unit E
Woburn, MA 01801

info@bluebirdgs.com
617.250.8500

CLIENT
DRESS BOSTON

ADDRESS
575 TREMONT ST
BOSTON, MA 02118

PROJECT
EXTERIOR SIGNAGE

JOB#
PROJ-00529

SUBMISSION DATE
11/14/2023

REVISION DATE
11/30/2023 KW
12/04/2023 KW
12/13/2023 DD
12/21/2023 DD

DESIGNER: K. WHITE, D.DUNCAN
PM: A. CLAYTON

SIGN TYPE	DRAWING
A	1.1



Endurance LED outdoor
sconce light, installed
by others

**NOTE: TOTAL SQUARE FOOTAGE OF SIGN TO BE
APPROXIMATELY 6.18' SQ. FT.**



BLUEBIRD
GRAPHIC SOLUTIONS

17 Everberg Road, Unit E
Woburn, MA 01801

info@bluebirdgs.com
617.250.8500

CLIENT
DRESS BOSTON

ADDRESS
575 TREMONT ST
BOSTON, MA 02118

PROJECT
EXTERIOR SIGNAGE

JOB#
PROJ-00529

SUBMISSION DATE
11/14/2023

REVISION DATE
12/04/2023
12/21/2023 DD

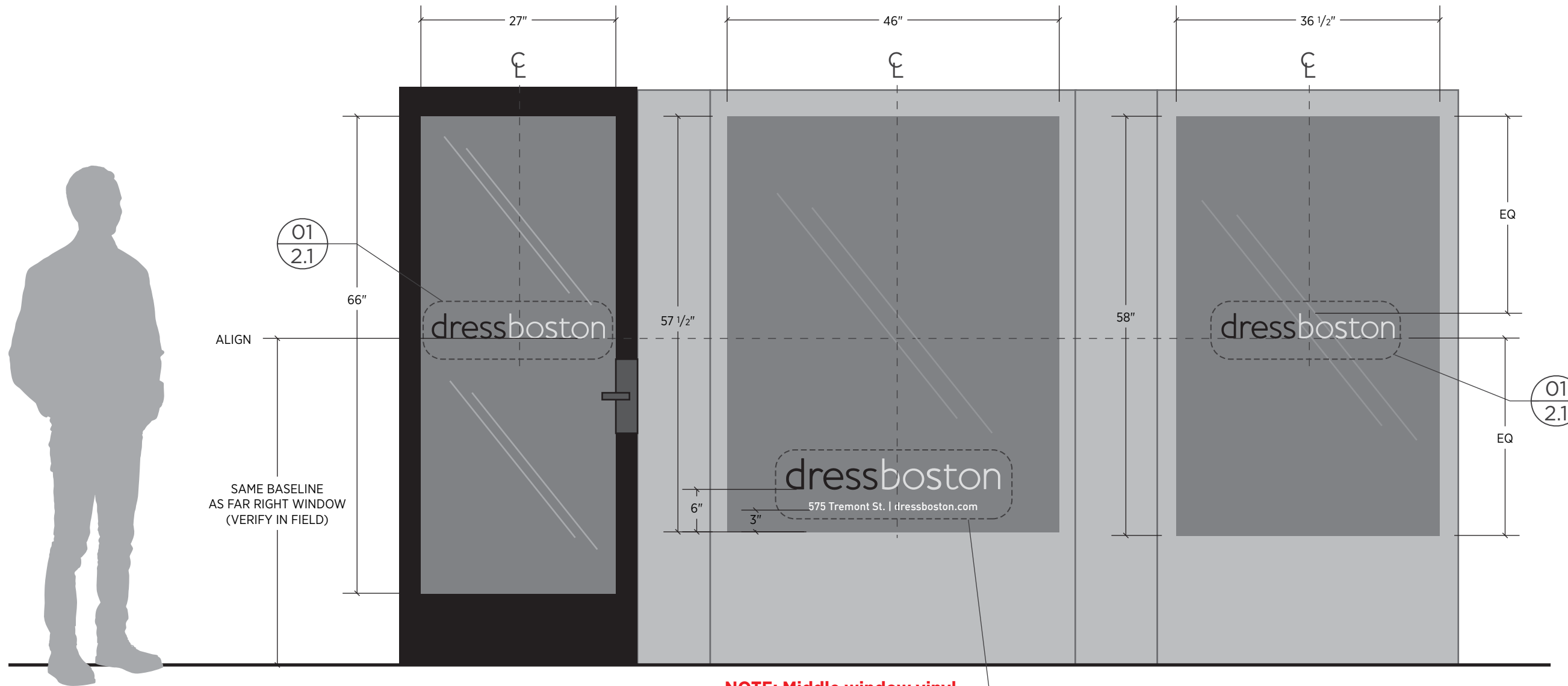

NOTE: Middle window vinyl final placement to be verified in the field with customer.

01 | ELEVATION
3/4" = 1'-0"

SIGN TYPE B - VINYL LOGOS

Quantity (3 SETS)

PALETTE

- VINYL: TO MATCH DUSTED CRYSTAL
- VINYL: TO MATCH MATTE BLACK
- VINYL: TO MATCH MATTE WHITE

DESIGNER: K. WHITE, D.DUNCAN
PM: A. CLAYTON

SIGN TYPE	DRAWING
B	2.0



BLUEBIRD
GRAPHIC SOLUTIONS

17 Everberg Road, Unit E
Woburn, MA 01801

info@bluebirdgs.com
617.250.8500

CLIENT
DRESS BOSTON

ADDRESS
575 TREMONT ST
BOSTON, MA 02118

PROJECT
EXTERIOR SIGNAGE

JOB #
PROJ-00529

SUBMISSION DATE
11/14/2023

REVISION DATE
12/04/2023
12/21/2023 DD

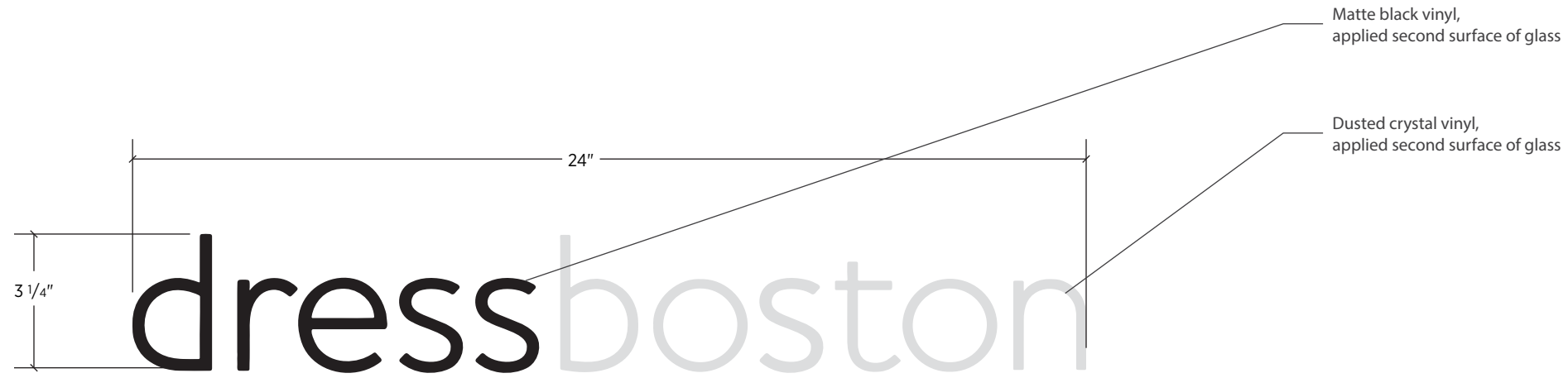

QTY 2

01 | VINYL 1
3" = 1'-0"

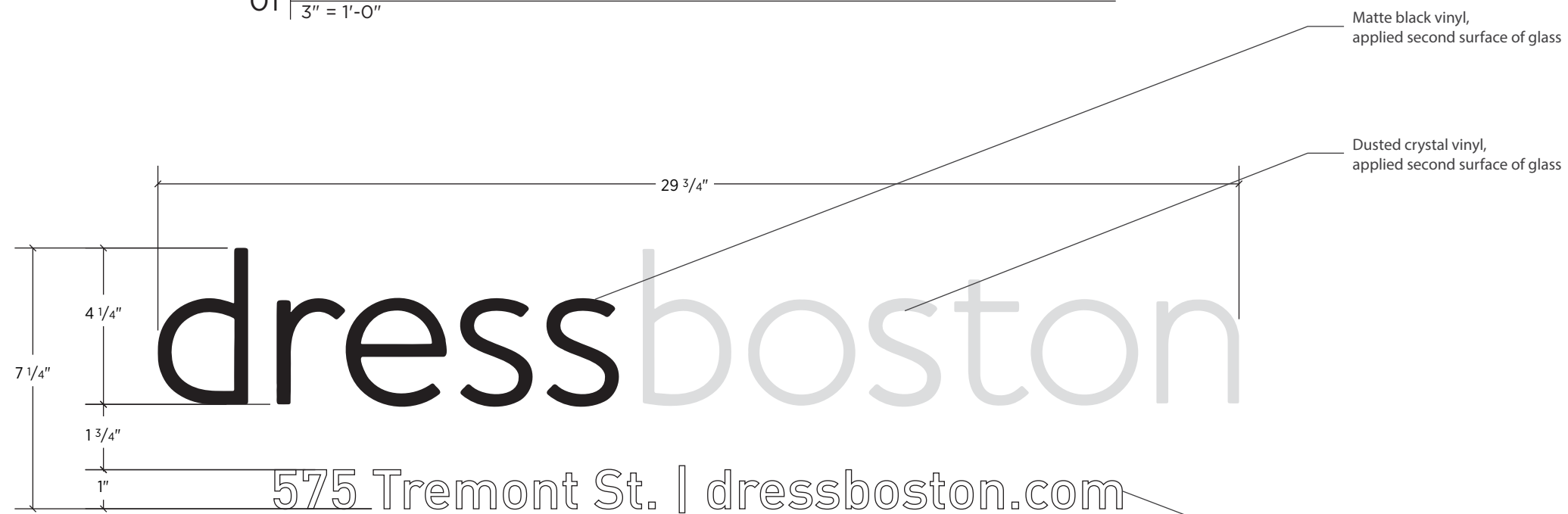

QTY 1

02 | VINYL 2
3" = 1'-0"

DESIGNER: K. WHITE, D.DUNCAN
PM: A. CLAYTON

SIGN TYPE	DRAWING
B	2.1