

BOQUERIA

EXTERIOR LOUVERS SUBMISSION

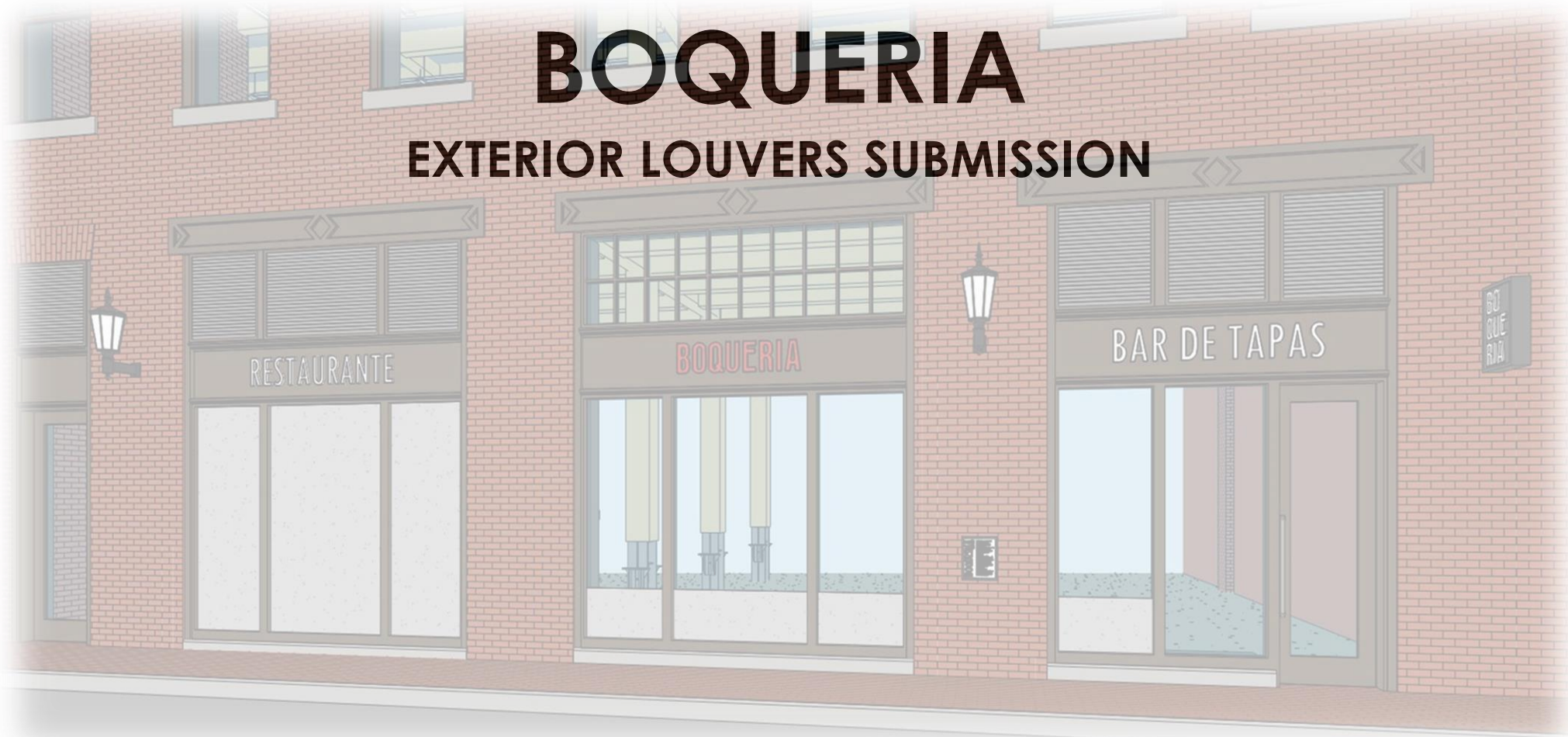

25 THOMSON PLACE

BOQUERIA

DESIGN REVIEW AGENDA

LOCATION OF BUILDING WITHIN DISTRICT

EXISTING PHOTOS

PROPOSED LOUVER ELEMENTS

- 25 THOMSON EXISTING CONDITIONS
- 25 THOMSON LOUVER DESIGN
- 25 THOMSON LOUVER DETAILS

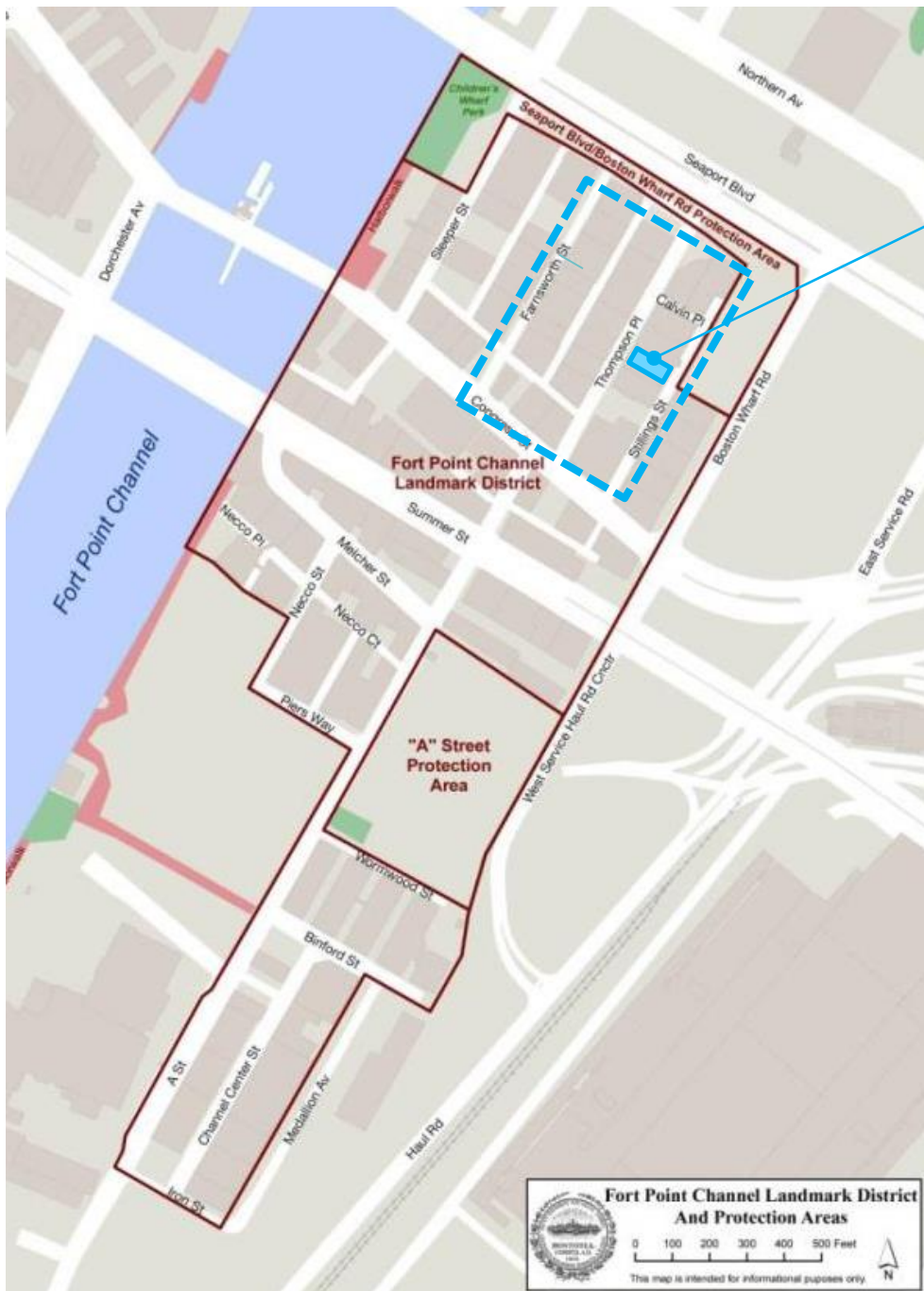

25 THOMSON PLACE



FORT POINT CHANNEL LANDMARK DISTRICT

PROJECT LOCATION MAPS



EXISTING CONDITION PHOTO

25 THOMSON PLACE – VIEW FROM STILLINGS STREET

BOQUERIA

3.9.2023

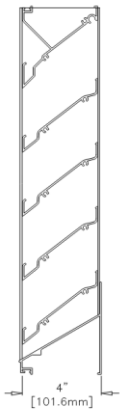

LOUVER DETAIL
(PAINT COLOR TO MATCH STOREFRONT)

REMOVE EXISTING LOUVER AND INFILL WITH SOLID PANEL

INTAKE & EXHAUST LOUVERS TO REPLACE TRANSOM GLAZING

INTAKE & EXHAUST LOUVERS TO REPLACE TRANSOM GLAZING

PAINTED WD DIVIDERS TO MATCH EXISTING STOREFRONT AND ALIGN WITH ELEMENTS BELOW



EXISTING GLAZED STOREFRONTS

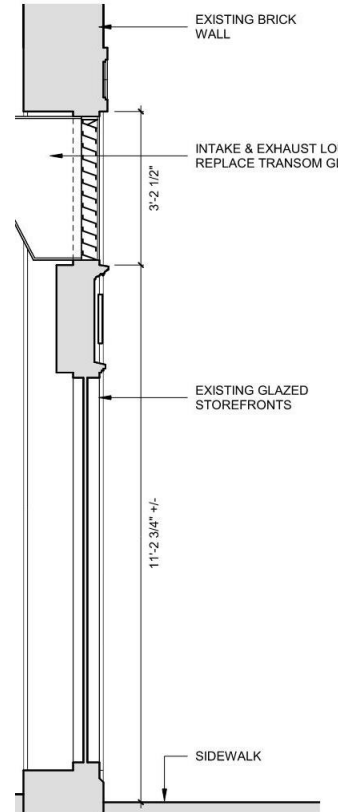

EXISTING BRICK WALL

INTAKE & EXHAUST LOUVER
REPLACE TRANSOM GLAZING

3'-2 1/2"

EXISTING GLAZED STOREFRONTS

11'-2 3/4" +/-

SIDEWALK

PROPOSED ELEVATION & WALL SECTION

STILLINGS STREET – EXTERIOR ELEVATION & WALL SECTION

INTRODUCE NEW LOUVERS IN THESE AREAS



REMOVE EXISTING EXHAUST PANEL AND INFILL WITH SOLID PANEL

LOUVER SCOPE

STILLINGS STREET VIEW – CONCEPTUAL RENDERING

BOQUERIA

3.9.2023



PERSPECTIVE OF LOUVERS AT FACADE

STILLINGS STREET VIEW – CONCEPTUAL RENDERING

BOQUERIA

3.9.2023



BOQUERIA