

Proposal for 1 Taylor Street Apt A

Contact info:
Skyler Kramer
Cell: 203-241-0235
Email: skykramer@gmail.com

Description of work:

Fireplace: 1 Taylor street apartment A contains an outdated firebox and brick chimney with a metal liner inside. The Firebox does not have a door, and the base of said box has subsequent rust rendering it in need of repair. Instead of repairing a dangerous and inefficient wood burning fire box, it is the proposal the owners (Skyler Kramer and Rebecca Smeltzer) to replace the firebox with a high efficiency gas fireplace. This fireplace itself while not in the purview of the South End Landmark District, will require a vent protruding from the existing brick chimney which is. It is the request of the owner to install a vent on the existing brick chimney that will be Copper or Copper in color and appearance. No additional holes will be created on the outside structure. The original chimney opening will be used. This type of vent is necessary to negate additional holes and is the safest and most efficient vent type. The alternative would be an intrusive direct vent that would require an additional hole in the unit.

Chimney Location

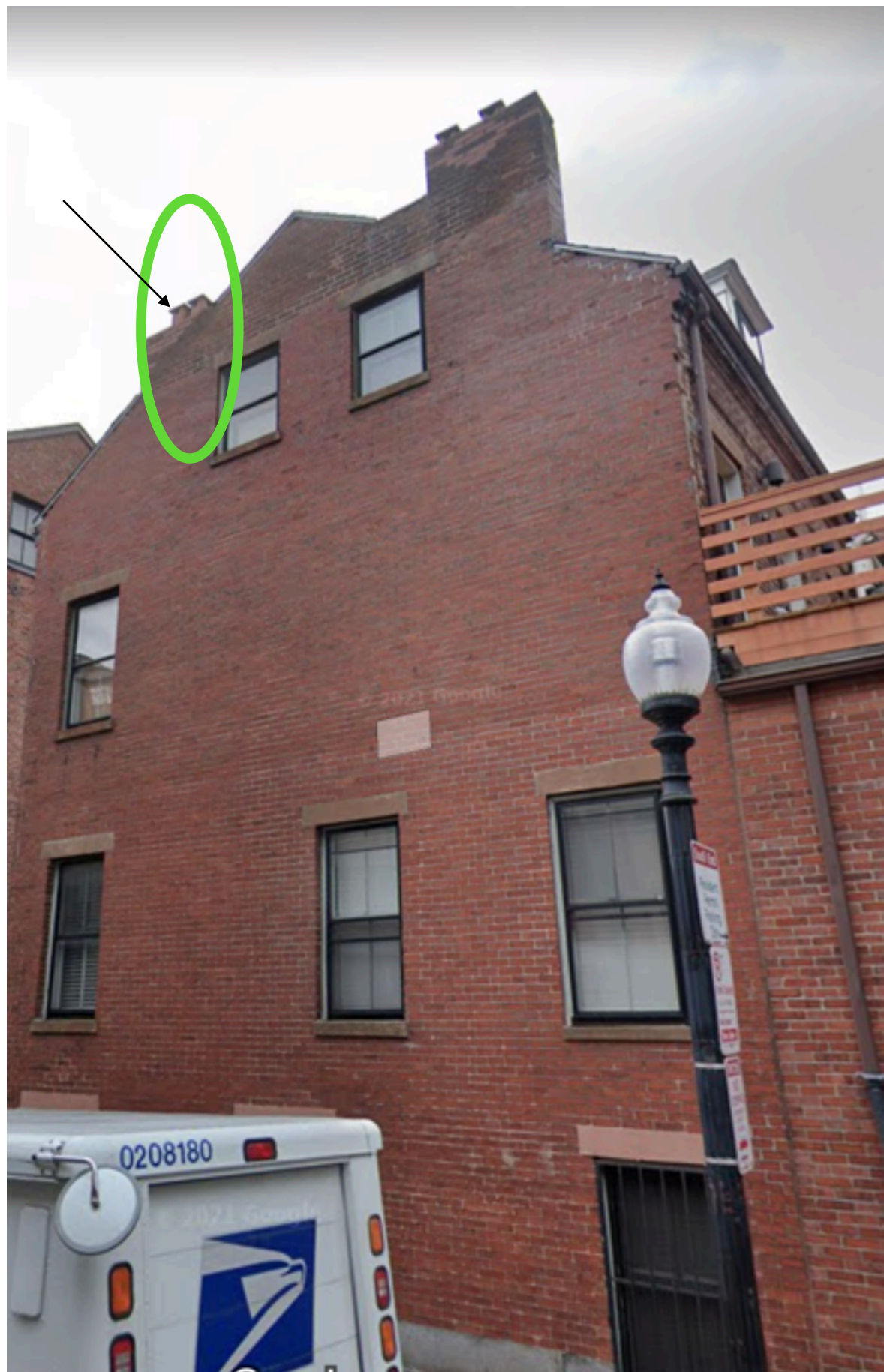

Chimney Location



Copper (painted) Cap



***Actual cap will be copper in color**



No additional holes will be made in the unit, original chimney hole will be used

***Actual cap will be copper in color**

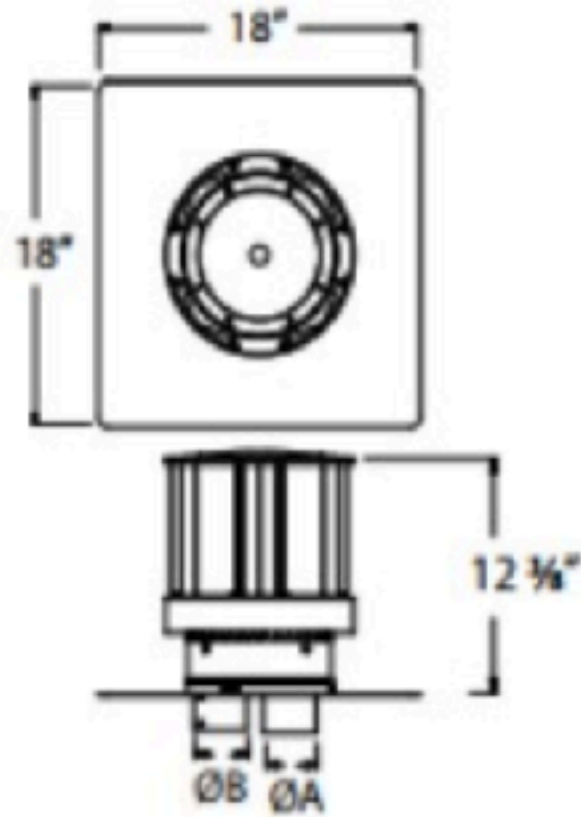

In depth view of vent, piping will be inserted into existing chimney opening

***Actual cap will be copper in color**

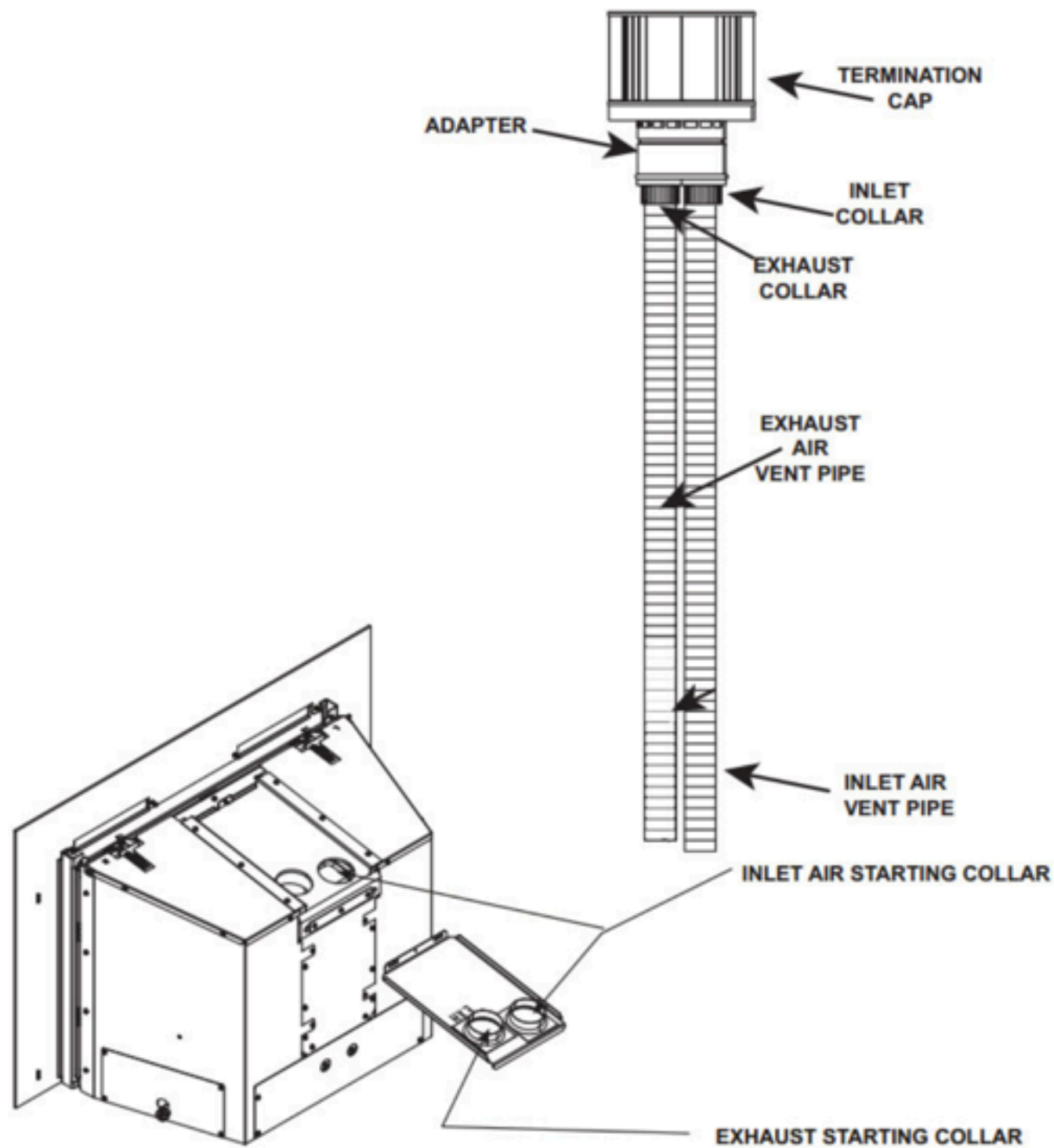
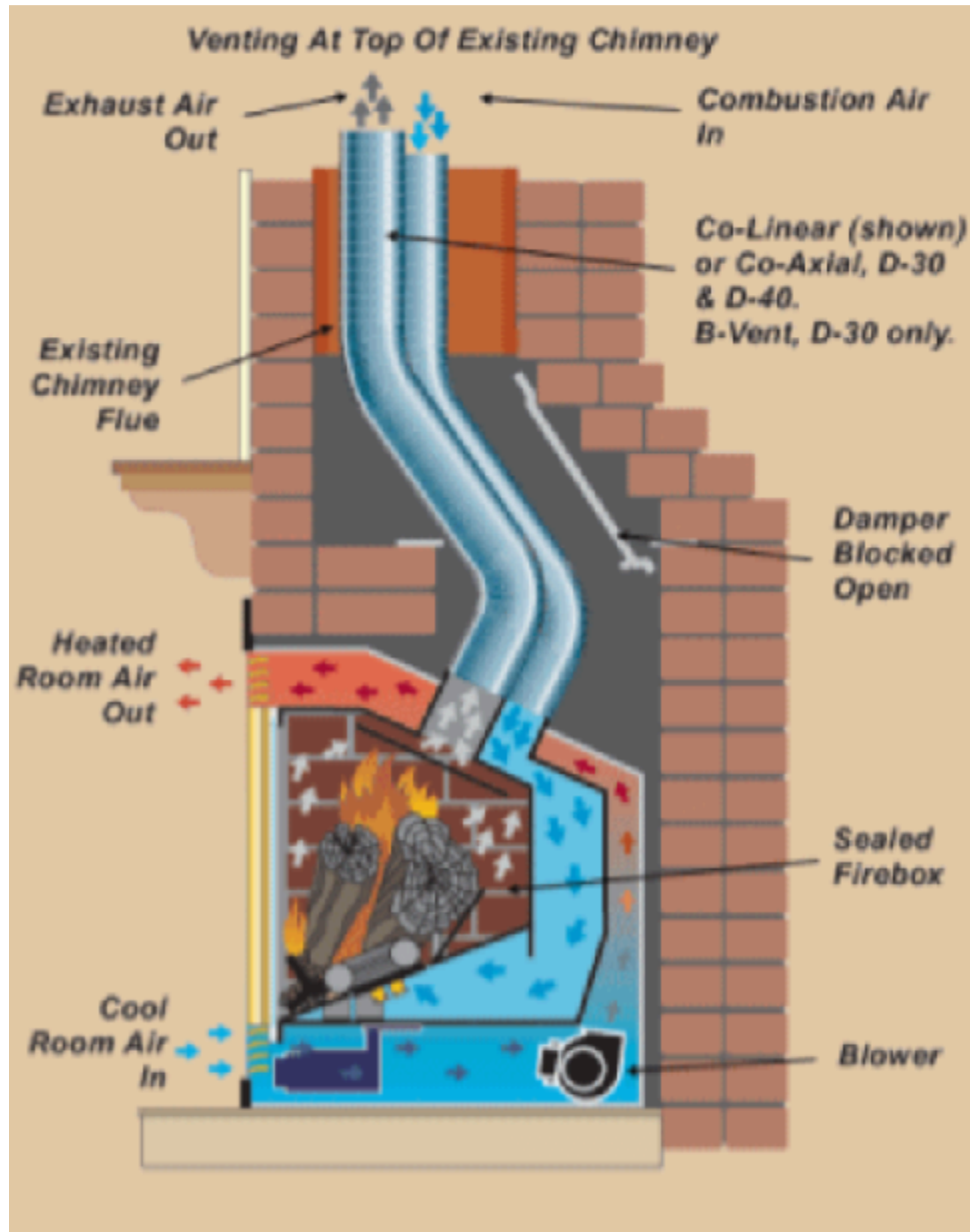

Diagram of interior pipe and connection to stove

***Actual cap will be copper in color**



Side view of chimney and highly efficient working stove

Examples of Vent cap on other South End homes:



10 Bond Street



46 Dartmouth Street



16 Bond street



85 Warren ave

Examples of Vent cap on other South End homes:



7-3 Upton Street



35 Upton Street



191 W Brookline Street



8 Ringgold Street