



ENVIRONMENTAL CONSULTANTS

Sound Science. Creative Solutions.®

15 Research Drive
Amherst, Massachusetts 01002
Tel 413.256.0202 Fax 413.256.1092
www.swca.com

March 17, 2022

Boston Conservation Commission
1 City Hall Square
Boston, MA 02201

Re: Charles River Vegetation Management Plan Notice of Intent

Dear Conservation Commission Members:

SWCA Environmental Consultants (SWCA) is submitting the enclosed updated Notice of Intent (NOI) on behalf of the Massachusetts Department of Conservation and Recreation (DCR) for continued general maintenance within the Charles River Reservation as well as specific focus areas for invasive plant management within the project work area. DCR is also updating the Charles River Vegetation Management Plan (CRVMP) and bank restoration project development concurrently with this filing to minimize the need for continued vegetation trimming in the future. Any edits made to the NOI narrative are marked with blue text and any edits to forms and figures are marked in the attached table.

All vegetation management activities will be carried out in a manner that has no potential for damage to the environment and all efforts will be made to avoid and minimize any potential impacts to the maximum extent practicable. These activities are limited to mowing, cutting, and pruning of vegetation as well as the removal of invasive vegetation. Any alteration associated with the proposed work includes the augmentation and sometimes destruction of vegetation (e.g., in the case of invasive plant removal). The following vegetation management activities are proposed in this NOI.

- Continued general maintenance: routine vegetation maintenance within landscaped areas, lawn, woodland, circulation, green infrastructure, DCR structures, meadow, and river's edge areas to be performed on a periodic basis (as has been performed in the past) to maintain valuable habitat, provide continued safe access to the public, and maintain recreational resources within the Charles River Reservation.
- Continued special event maintenance: trimming vegetation to 24 inches within the riparian zone prior to specific events (once annually for each event, as has been performed in the past) to maintain historic view corridors and manage safe access for emergency personnel during the Head of the Charles Regatta and the Fourth of July Celebration.
- Invasive plant management focus areas: DCR has identified a total of four focus areas for invasive plant management, that align with their broader goals for the CRVMP, to restore the natural capacity of the existing wetland resource areas to sustain the interests of the Wetlands Protection Act through the restoration of native vegetation and ecological integrity of the Charles River Reservation.

This filing was originally submitted on April 20, 2022 with a check for the Boston portion of the filing fee (\$300) as well as the fee for projects with a fair cost of more than \$10,000 (\$1,500) and all required filing documents.

Sincerely,

A handwritten signature in black ink that reads 'Naomi Valentine'. The signature is written in a cursive, flowing style.

Naomi Valentine
Ecological Restoration Team Lead

	Conservation Commission Comment	SWCA Response	Section Referenced
1	Is this project subject to MEPA review? If so, please include proof it was noticed in the Environmental Monitor.	The majority of the proposed work falls under the category of routine maintenance. Therefore, the MEPA review thresholds do not apply. Invasive plant management is the only scope item that could trigger MEPA thresholds. However, in reviewing project impacts, invasive management is below the review thresholds and the project description has been posted as an Ecological Restoration project in the Environmental Monitor.	N/A
2	Sections A.4 and C.1 on the Boston NOI form were not completed.	A.4 (representative info) was filled out in filing Q: was this what you meant to reference? C.1 (other applicable standards & requirements) have been added: "Orders of Conditions are needed in the three other municipalities (Cambridge, Watertown, and Newton) within the Charles River Reservation (South Basin). No other permits are required for this vegetation management plan."	Boston NOI Form
3	The FEMA Firm was not included with the NOI.	This has been included as Figure 7 – the FEMA Firm layer over the project extent.	Appendix C
4	The translated notice with the project information, translation certification, and the babel notice were not included with the NOI.	These were sent to the Conservation Commission on 4/27/22 and are included in this updated filing. The Babel Notice was sent on 5/5/22.	Appendix B
5	The plans provided were not stamped. At a minimum, stamped site surveys/delineations should be provided for the BVW/IVW onsite specifically referencing the wetland flags noted in the narrative.	SWCA has included an additional figure (Figure 8) with a larger scale of all delineated wetlands and their flag numbers. Since all flags were geolocated with a sub-meter accurate GPS unit and stamped plans would not offer further detail/accurate information, SWCA requests that this requirement be waived. Previous filings have been accepted with similar detail. Is this accepted?	Appendix C
6	Lawn maintenance is not subject to the Act, and therefore should not be quantified in the NOI.	These impacts have been removed from the filing for the Lawn Landscape Type. Additionally, the following Landscape Types' impact calculations have been adjusted to remove this impact: Woodland (T): only 1% of polygon includes non-mowing impact Landscape Areas (LA): only 10% include non-mowing impact Green Infrastructure (GI): only 15% include active management/impact Structure (S): only 50% includes active management/impact	Form 3 Boston NOI Form Table 3 (narrative) Table 5 (narrative) Table 9 (narrative)
7	Please include a section in the narrative addressing the status of the tree inventory, as well as more detail on the proposed tree removal (the Commission will likely request the tree inventory prior to closing the hearing as to better evaluate the VMP).	DCR is currently contracting an arborist (Bartlett Tree) to complete a tree inventory (Section 2.1.1 and Appendix E). Text added to NOI: "The Esplanade Association and Harvard Boathouse staff have already updated their tree inventory, the results of which have been submitted to the Conservation Commission. DCR is currently contracting Bartlett Tree to finish the remainder of the tree survey within the 2022 calendar year. The results will be submitted to the Conservation Commission. The full details of this update are included in Appendix E. Tree maintenance and continued monitoring is a large-scale effort for the proposed project and will be reported on annually as updated data and/or tree maintenance are needed. DCR requests that the updated tree survey and ongoing specific maintenance details be presented to the Boston Conservation Commission in annual reporting and not be required in their entirety under this filing due to the very large scale of the project. No tree removal or maintenance will take place until the arboreal study is completed. The only exception to this is if there are trees threatening public health and safety."	Section 2.1.1 Appendix E
8	The NOI states this project qualifies as an ecological restoration project "Other," furthering three interests of the Act (storm damage prevention, prevention of pollution, and protection of wildlife habitat). The narrative should include a discussion on how this project furthers those interests and complies with the provisions at 310 CMR 10.53(1), (2), (7), and (8).	This is being filed as an Ecological Restoration Limited Project because of the overall restoration goals of the project. General historic maintenance (Landscape Types and special events maintenance) is planned to be reduced in multiple manners: (1) restoration of riparian areas following results of test plots [DEP File No. 006-1780] (2) conversion of underutilized lawn to native meadow, and (3) overall resilient stewardship goals included in Section 1 (Introduction). Table 10 includes responses to the General Provisions for all wetlands (310 CMR 10.03), which mirrors much of what is included in the General Provisions for Inland Wetlands (310 CMR 10.53). However, elaboration has been added to respond to 310 CMR 10.53(1), (2), (7), and (8).	Table 8 (existing and added text) Section 5.3.1 (new section) Table 10

	Conservation Commission Comment	SWCA Response	Section Referenced
9	The Commission has promulgated regulations and performance standards related to IVW that officially took effect on April 8. The IVW performance standards should be included in Section 6, as should the language from the Ordinance on the Waterfront Area.	This has been added to the filing. The only impact to IVW is the management of invasive phragmites (<i>Phragmites australis</i>).	Section 6.5
10	The narrative should include a discussion on climate change as it relates to the proposed project.	This detail is included in the Introduction and has been elaborated on in the narrative.	Section 1
11	The way the work in different landscape types is broken up is very confusing, especially in relation to the way wetlands are classified under the Act. Please make sure it is clear what the total impacts are to each wetland resource area under the Act and the Ordinance, regardless of what type of landscape those areas are classified as.	This has been edited on the figures and in the text. The “Wetland (W)” Landscape Type has been removed and the BVW and IVW have been symbolized on the map instead. No maintenance work was ever proposed within BVW and IVW - only invasive plant management. Updates to impacts have been updated.	Table 3 (narrative) Table 5 (narrative) Table 9 (narrative)
12	The Dragon Boat Festival is mentioned in the cover letter, but is not referenced anywhere else in the NOI. Is any event-specific work being proposed for this event?	This was an update error, which has been fixed. It has been decided that there is no vegetation management associated with the Dragon Boat Festival in Boston. The only management associated with the Dragon Boat Festival is located in Cambridge.	Cover Letter
13	Section 5.1 - There are conflicting statements as to whether there are AULs on the project site or not. Please clarify this.	This was updated in the narrative. There are no AULs present.	Section 5.1
14	The breakdowns of maintenance and impacts are not clear. The Commission specifically requested revisions to DCR's Aquatic VMP that specifically address this comment. We highly recommend you review the Aquatic VMP as to how the Commission wants the information presented for its consideration.	See statement above (Comment 11). Impacts per maintenance type are clearly broken out in Tables in the narrative and have been updated accordingly. Total impacts for the project are also included in the narrative.	Table 5 (narrative) Table 7 (narrative) Table 9 (narrative)
15	Section 5.2 - What defines target vegetation? Does this refer to all vegetation or to specific species?	Target vegetation includes nuisance (i.e., indigo) and invasive vegetation – native vegetation shall be avoided during trimming.	Section 5.2
16	5.3 - No restoration plan is provided. What specifically is being proposed as restoration work?	The filing has been revised to include the restoration plans from the Test Plot Notice of Intent. DCR is working on developing restoration approaches to specific section of the riparian zones within the project area. The results of the Test Plots will determine what vegetation and restoration approach will be best in various terrains/sections of the Reservation. DCR will submit an annual plan to the Conservation Commission regarding which sections are to be restored each year and will include which restoration design is to be implemented in each area. DCR is available to accompany the Conservation Commission on site visit prior to approval of each annual plan if the Commission prefers to include that as a special condition of the work.	Appendix E
17	7.3 - The discussion of the means and methods is lacking. Please provide more details on the work that is being proposed and how it will be done, especially in regards to herbicide application (which herbicides are proposed in which areas, when and how will they be applied, etc.) and the breakdown of work to be done by volunteers and by professionals.	These details are included in the following locations of the submittal: General Maintenance in Landscape Type polygons: conducted per Table 4 and Appendix E Special Events: conducted per Table 6 Invasive Management: Table 6 and Appendix F (Section 7.3 includes minimization and avoidance techniques only)	Table 4 Appendix E Table 6 Appendix F

	Conservation Commission Comment	SWCA Response	Section Referenced
18	The alternatives analysis should include more detail on the alternatives considered, and should also include a justification for the selected/preferred alternative.	This has been updated.	Appendix A
19	It is unclear if this VMP is intended to cover the installation of the temporary docks, or if these docks will be included under separate filings.	Temporary dock locations are included in this filing ONLY to signify where vegetation is cut flush to the bank, as opposed to a 24-inch trimming. The dock installation itself is not a part of this filing.	N/A
20	The VMP only extends to the old locks, rather than the Charles River Dam. Is any work being proposed at North Point Park or along other portions of the Reservation extending to the Dam?	This has been extended and calculations have been updated, as have all figures.	Form 3 Boston NOI Form NOI Narrative Appendix C

Additional Comments and Responses based on the Peer Review Conducted for the Cambridge Filing of This Project

	Cambridge Peer Review Comment	SWCA Response	Section Referenced
1	Include text stating the project is being filed as an Ecological Restoration Limited Project with text stating specifically why DCR believes the project meets the project criteria.	Added: "This NOI is being filed as an Ecological Restoration Limited Project as an invasive vegetation management and plans to further the following interests of the act: storm damage prevention, prevention of pollution, and protection of wildlife habitat. Please reach out with any questions."	Already addressed in Boston Comment 8
2	Provide explanation for why the project is exempt from provisions of the MassDEP Stormwater Standards	There will be no alteration to existing stormwater management. Where vegetation is trimmed or removed, stormwater BMPs will be in place to ensure proper management of stormwater (as required for general management plans). [Added to Introduction]	Section 1
3	Impacts should only be reported under "size of proposed alteration". "Proposed replacement" should only be filled out if you plan to compensate for losses with mitigation.	No precise amount of restoration has yet been calculated. However, the goal is to restore large sections of riparian area, currently mown areas, etc. with resilient native vegetation and restored to native meadow, respectively.	WPA Form 3 Boston NOI Form
4	It is not clear if Section 2 is intended to present only vegetation management activates currently occurring and those that are planned under the revised CRVMP. - Recommend presenting proposed work in Section 5 alone	Some proposed text was accidentally included in Section 2. This section includes details on the locations of all management to occur alone. All proposed work has been moved to Section 5.	Moved from Section 2 to Section 5
5	Text states that DCR performs various types of regular maintenance, with no additional detail.	All activities associated with regular maintenance are included in Table 4 and elaborated on in Appendix E. - No additional text added.	Table 4 Appendix E
6	Recommend expanding on the changes in routine maintenance (active management to passive landscape units with more native species) to include more detail.	1. Restoration of riparian areas following results of test plots (currently being monitored in Boston within the Reservation) 2. Conversion of underutilized lawn to native meadow Specific plans will be submitted to the Conservation Commission prior to implementation annually.	Section 5.3
7	Clarify narrative regarding special events. Narrative mentions "one-time trimming".	Existing text from this section: "As these are short-term events, they only require vegetation management at one discrete time each year, leading up to their scheduled date." Added additional repetition of this explanation to Table; "one-time trimming" has been changed to "once-annual trimming"	Section 5.2

	Cambridge Peer Review Comment	SWCA Response	Section Referenced
8	Narrative does not explain how routine vegetation management and special event vegetation management activities qualify as Ecological Restoration. Recommend clarifying text to explain how the project meets these goals.	Noted in previous comment: The proposed restoration of River’s Edge (and general riparian area) will increase storm damage prevention (existing conditions are conducive to erosion), pollution prevention, and protection of wildlife habitat (revegetating with more suitable native habitat).	Already addressed in Boston Comment 8 and Cambridge Comment 1
9	Clarify terminology throughout text between “Regulated resource area”, “wetland resource area”, and “jurisdictional resource area”	As commented, these all mean the same thing. They have all been changed to “regulated wetland resource area”.	Throughout narrative
10	Explanation of why trimming of desirable vegetation within BLSF and other regulated wetland resource areas will not degrade wildlife habitat functions requires further explain how the work will be performed to encourage desirable veg and avoid impacts to existing habitat.	DCR’s ultimate goal is to eliminate or reduce all special event trimming. This will be eliminated by replacing the existing non-native and invasive bank and riverfront area vegetation with low growing native vegetation. Unfortunately, the trimming area is very large, and the effort will be slow and costly. BMPs are included to minimize impacts.	Section 6.3
11	Recommend removing the term “mitigate” from this Section. Also, recommend including seasonal work window restrictions for various activities, such as tree/shrub pruning, to protect wildlife habitat and further ecological restoration goals.	“Mitigate” has been changed to “restore” in all locations. The only trimming planed occurs just prior to the special events. The timing for these is within three weeks of each event. Any nests are avoided.	Section 7
12	Alternatives analysis currently only examines alternatives for special event vegetation management associated with the Head of the Charles Regatta. – Include alternatives for all activities proposed	All vegetation trimming for special events includes the same scope of work as the HOC There are no alternatives to general maintenance. Invasive control includes a full range of options.	Appendix A; Alternatives Analysis

Charles River Vegetation Management Plan

Notice of Intent Submittal

Boston, Massachusetts

MAY 2022

PREPARED ON BEHALF OF

**Massachusetts Department of
Conservation and Recreation**

PREPARED BY

SWCA Environmental Consultants

Massachusetts Department of Environmental Protection

Bureau of Resource Protection - Wetlands

WPA Form 3 - Notice of Intent

Massachusetts Wetlands Protection Act M.G.L. c. 131, §40

Provided by MassDEP:
MassDEP File #:
eDEP Transaction #:1365251
City/Town:BOSTON

A.General Information

1. Project Location:

a. Street Address CHARLES RIVER RESERVATION
b. City/Town BOSTON c. Zip Code 02114
d. Latitude 42.35143N Longitude 71.10509W
f. Map/Plat # N/A g.Parcel/Lot 2203416000; 2202748000; 2200577000 ; 2200470000; 2200302000; 2200103000; # 0503747000; 2100370000; 0502498000; 0300943000

2. Applicant:

Individual Organization

a. First Name DANIELLE b.Last Name MELLETT
c. Organization DEPARTMENT OF CONSERVATION AND RECREATION
d. Mailing Address 251 CAUSEWAY STREET, SUITE 900
e. City/Town BOSTON f. State MA g. Zip Code 02114
h. Phone Number i. Fax j. Email danielle.mellett@state.ma.us

3.Property Owner:

more than one owner

a. First Name b. Last Name
c. Organization
d. Mailing Address CHARLES RIVER RESERVATION
e. City/Town f.State g. Zip Code
h. Phone Number i. Fax j.Email

4.Representative:

a. First Name NAOMI b. Last Name VALENTINE
c. Organization SWCA ENVIRONMENTAL CONSULTANTS
d. Mailing Address 15 RESEARCH DRIVE
e. City/Town AMHERST f. State MA g. Zip Code 01002
h.Phone Number 413-658-2012 i.Fax j.Email nvalentine@swca.com

5.Total WPA Fee Paid (Automatically inserted from NOI Wetland Fee Transmittal Form):

a.Total Fee Paid 750.00 b.State Fee Paid 362.50 c.City/Town Fee Paid 387.50

6.General Project Description:

THE PROPOSED PROJECT IS FOR THE UPDATED CHARLES RIVER VEGETATION MANAGEMENT PLAN, WHICH INCLUDES THE CONTINUATION OF ROUTINE MAINTENANCE OF THE CHARLES RIVER RESERVATION (LANDS, LANDSCAPED AREAS, GREEN INFRASTRUCTURE, STRUCTURES, CIRCULATION, WOODLAND, MEADOW, AND RIVER'S EDGE), CONTINUED VEGETATION MANAGEMENT FOR ANNUAL SPECIAL EVENTS, AND PROPOSED INVASIVE PLANT MANAGEMENT IN FOUR SPECIFIC FOCUS AREAS WITHIN THE BOSTON PORTION OF THE RESERVATION.

Massachusetts Department of Environmental Protection

Bureau of Resource Protection - Wetlands

WPA Form 3 - Notice of Intent

Massachusetts Wetlands Protection Act M.G.L. c. 131, §40

Provided by MassDEP:
 MassDEP File #:
 eDEP Transaction #:1365251
 City/Town:BOSTON

2. Width of Riverfront Area (check one) 25 ft. - Designated Densely Developed Areas only
 100 ft. - New agricultural projects only
 200 ft. - All other projects

3. Total area of Riverfront Area on the site of the proposed project 2452864 square feet

4. Proposed Alteration of the Riverfront Area:

118,022 118,022
 a. total square feet b. square feet within 100 ft. c. square feet between 100 ft. and 200 ft.

5. Has an alternatives analysis been done and is it attached to this NOI? Yes No
 6. Was the lot where the activity is proposed created prior to August 1, 1996? Yes No

3.Coastal Resource Areas: (See 310 CMR 10.25 - 10.35)

Resource Area	Size of Proposed Alteration	Proposed Replacement (if any)
a. <input type="checkbox"/> Designated Port Areas	Indicate size under	Land under the ocean below,
b. <input type="checkbox"/> Land Under the Ocean	1. square feet	
	2. cubic yards dredged	
c. <input type="checkbox"/> Barrier Beaches	Indicate size under Coastal Beaches and/or Coastal Dunes, below	
d. <input type="checkbox"/> Coastal Beaches	1. square feet	2. cubic yards beach nourishment
e. <input type="checkbox"/> Coastal Dunes	1. square feet	2. cubic yards dune nourishment
f. <input type="checkbox"/> Coastal Banks	1. linear feet	
g. <input type="checkbox"/> Rocky Intertidal Shores	1. square feet	
h. <input type="checkbox"/> Salt Marshes	1. square feet	2. sq ft restoration, rehab, crea.
i. <input type="checkbox"/> Land Under Salt Ponds	1. square feet	
	2. cubic yards dredged	
j. <input type="checkbox"/> Land Containing Shellfish	1. square feet	
k. <input type="checkbox"/> Fish Runs	Indicate size under Coastal Banks, Inland Bank, Land Under the Ocean, and/or inland Land Under Waterbodies and Waterways, above	
	1. cubic yards dredged	
l. <input type="checkbox"/> Land Subject to Coastal Storm Flowage	1. square feet	

□ **Massachusetts Department of Environmental Protection**

Bureau of Resource Protection - Wetlands

WPA Form 3 - Notice of Intent

Massachusetts Wetlands Protection Act M.G.L. c. 131, §40

Provided by MassDEP:

MassDEP File #:

eDEP Transaction #:1365251

City/Town:BOSTON

4.Restoration/Enhancement

Restoration/Replacement

If the project is for the purpose of restoring or enhancing a wetland resource area in addition to the square footage that has been entered in Section B.2.b or B.3.h above, please entered the additional amount here.

a. square feet of BVW

b. square feet of Salt Marsh

5.Projects Involves Stream Crossings

Project Involves Streams Crossings

If the project involves Stream Crossings, please enter the number of new stream crossings/number of replacement stream crossings.

a. number of new stream crossings

b. number of replacement stream crossings

C. Other Applicable Standards and Requirements

Streamlined Massachusetts Endangered Species Act/Wetlands Protection Act Review

1. Is any portion of the proposed project located in **Estimated Habitat of Rare Wildlife** as indicated on the most recent Estimated Habitat Map of State-Listed Rare Wetland Wildlife published by the Natural Heritage of Endangered Species program (NHESP)?

a. Yes No

If yes, include proof of mailing or hand delivery of NOI to:

Natural Heritage and Endangered Species

Program

Division of Fisheries and Wildlife

1 Rabbit Hill Road

Westborough, MA 01581

b. Date of map:FROM MAP VIEWER

If yes, the project is also subject to Massachusetts Endangered Species Act (MESA) review (321 CMR 10.18)...

c. Submit Supplemental Information for Endangered Species Review * (Check boxes as they apply)

1. Percentage/acreage of property to be altered:

(a) within Wetland Resource Area

percentage/acreage

(b) outside Resource Area

percentage/acreage

2. Assessor's Map or right-of-way plan of site

3. Project plans for entire project site, including wetland resource areas and areas outside of wetland jurisdiction, showing existing and proposed conditions, existing and proposed tree/vegetation clearing line, and clearly demarcated limits of work **

a. Project description (including description of impacts outside of wetland resource area & buffer zone)

b. Photographs representative of the site

c. MESA filing fee (fee information available at: <http://www.mass.gov/eea/agencies/dfg/dfw/natural-heritage/regulatory-review/mass-endangered-species-act-mesa/esa-fee-schedule.html>)

Make check payable to "Natural Heritage & Endangered Species Fund" and **mail to NHESP** at above address

Projects altering 10 or more acres of land, also submit:

d. Vegetation cover type map of site

□ **Massachusetts Department of Environmental Protection**

Bureau of Resource Protection - Wetlands

WPA Form 3 - Notice of Intent

Massachusetts Wetlands Protection Act M.G.L. c. 131, §40

Provided by MassDEP:
MassDEP File #:
eDEP Transaction #:1365251
City/Town:BOSTON

e. Project plans showing Priority & Estimated Habitat boundaries

d. OR Check One of the following

1. Project is exempt from MESA review. Attach applicant letter indicating which MESA exemption applies. (See 321 CMR 10.14, <http://www.mass.gov/eea/agencies/dfg/dfw/laws-regulations/cmr/321-cmr-1000-massachusetts-endangered-species-act.html#10.14>; the NOI must still be sent to NHESP if the project is within estimated habitat pursuant to 310 CMR 10.37 and 10.59.)

2. Separate MESA review ongoing.

a. NHESP Tracking Number

b. Date submitted to NHESP

3. Separate MESA review completed.

Include copy of NHESP "no Take" determination or valid Conservation & Management Permit with approved plan.

* Some projects **not** in Estimated Habitat may be located in Priority Habitat, and require NHESP review...

2. For coastal projects only, is any portion of the proposed project located below the mean high waterline or in a fish run?

a. Not applicable - project is in inland resource area only

b. Yes No

If yes, include proof of mailing or hand delivery of NOI to either:

South Shore - Cohasset to Rhode Island, and the Cape & Islands:

North Shore - Hull to New Hampshire:

Division of Marine Fisheries -
Southeast Marine Fisheries Station
Attn: Environmental Reviewer
836 S. Rodney French Blvd
New Bedford, MA 02744

Division of Marine Fisheries -
North Shore Office
Attn: Environmental Reviewer
30 Emerson Avenue
Gloucester, MA 01930

If yes, it may require a Chapter 91 license. For coastal towns in the Northeast Region, please contact MassDEP's Boston Office. For coastal towns in the Southeast Region, please contact MassDEP's Southeast Regional office.

3. Is any portion of the proposed project within an Area of Critical Environmental Concern (ACEC)?

a. Yes No

If yes, provide name of ACEC (see instructions to WPA Form 3 or DEP Website for ACEC locations). **Note:** electronic filers click on Website.

b. ACEC Name

4. Is any portion of the proposed project within an area designated as an Outstanding Resource Water (ORW) as designated in the Massachusetts Surface Water Quality Standards, 314 CMR 4.00?

a. Yes No

5. Is any portion of the site subject to a Wetlands Restriction Order under the Inland Wetlands Restriction Act (M.G.L.c. 131, § 40A) or the Coastal Wetlands Restriction Act (M.G.L.c. 130, § 105)?

a. Yes No

6. Is this project subject to provisions of the MassDEP Stormwater Management Standards?

a. Yes, Attach a copy of the Stormwater Report as required by the Stormwater Management Standards per 310 CMR 10.05(6)(k)-(q) and check if:

1. Applying for Low Impact Development (LID) site design credits (as described in Stormwater Management Handbook

□ **Massachusetts Department of Environmental Protection**

Bureau of Resource Protection - Wetlands

WPA Form 3 - Notice of Intent

Massachusetts Wetlands Protection Act M.G.L. c. 131, §40

Provided by MassDEP:
MassDEP File #:
eDEP Transaction #:1365251
City/Town:BOSTON

- Vol.2, Chapter 3)
- 2. A portion of the site constitutes redevelopment
- 3. Proprietary BMPs are included in the Stormwater Management System

b. No, Explain why the project is exempt:

- 1. Single Family Home
- 2. Emergency Road Repair
- 3. Small Residential Subdivision (less than or equal to 4 single-family houses or less than or equal to 4 units in multi-family housing project) with no discharge to Critical Areas.

D. Additional Information

Applicants must include the following with this Notice of Intent (NOI). See instructions for details.

Online Users: Attach the document transaction number (provided on your receipt page) for any of the following information you submit to the Department by regular mail delivery.

- 1. USGS or other map of the area (along with a narrative description, if necessary) containing sufficient information for the Conservation Commission and the Department to locate the site. (Electronic filers may omit this item.)
- 2. Plans identifying the location of proposed activities (including activities proposed to serve as a Bordering Vegetated Wetland [BVW] replication area or other mitigating measure) relative to the boundaries of each affected resource area.
- 3. Identify the method for BVW and other resource area boundary delineations (MassDEP BVW Field Data Form(s). Determination of Applicability, Order of Resource Area Delineation, etc.), and attach documentation of the methodology.
- 4. List the titles and dates for all plans and other materials submitted with this NOI.

a. Plan Title: b. Plan Prepared By: c. Plan Signed/Stamped By: d. Revised Final Date: e. Scale:

- 5. If there is more than one property owner, please attach a list of these property owners not listed on this form.
- 6. Attach proof of mailing for Natural Heritage and Endangered Species Program, if needed.
- 7. Attach proof of mailing for Massachusetts Division of Marine Fisheries, if needed.
- 8. Attach NOI Wetland Fee Transmittal Form.
- 9. Attach Stormwater Report, if needed.



Massachusetts Department of Environmental Protection
Bureau of Resource Protection - Wetlands

WPA Form 3 – Notice of Intent

Massachusetts Wetlands Protection Act M.G.L. c. 131, §40

Provided by MassDEP:	
MassDEP File Number	
1365251	
Document Transaction Number	
Boston	
City/Town	

F. Signatures and Submittal Requirements

I hereby certify under the penalties of perjury that the foregoing Notice of Intent and accompanying plans, documents, and supporting data are true and complete to the best of my knowledge. I understand that the Conservation Commission will place notification of this Notice in a local newspaper at the expense of the applicant in accordance with the wetlands regulations, 310 CMR 10.05(5)(a).

I further certify under penalties of perjury that all abutters were notified of this application, pursuant to the requirements of M.G.L. c. 131, § 40. Notice must be made by Certificate of Mailing or in writing by hand delivery or certified mail (return receipt requested) to all abutters within 100 feet of the property line of the project location.

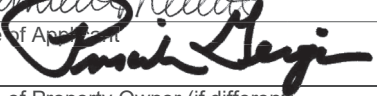
 1. Signature of Applicant	4/12/22
 3. Signature of Property Owner (if different) Naomi Valentine	4/12/22
<small>Digitally signed by Naomi Valentine Date: 2022.04.12 10:45:45 -04'00'</small> 5. Signature of Representative (if any)	4/12/22
2. Date	4/12/22
4. Date	4/12/22
6. Date	4/12/22

For Conservation Commission:

Two copies of the completed Notice of Intent (Form 3), including supporting plans and documents, two copies of the NOI Wetland Fee Transmittal Form, and the city/town fee payment, to the Conservation Commission by certified mail or hand delivery.

For MassDEP:

One copy of the completed Notice of Intent (Form 3), including supporting plans and documents, one copy of the NOI Wetland Fee Transmittal Form, and a **copy** of the state fee payment to the MassDEP Regional Office (see Instructions) by certified mail or hand delivery.

Other:

If the applicant has checked the "yes" box in any part of Section C, Item 3, above, refer to that section and the Instructions for additional submittal requirements.

The original and copies must be sent simultaneously. Failure by the applicant to send copies in a timely manner may result in dismissal of the Notice of Intent.

□ **Massachusetts Department of Environmental Protection**
Bureau of Resource Protection - Wetlands
WPA Form 3 - Notice of Intent
Massachusetts Wetlands Protection Act M.G.L. c. 131, §40

Provided by MassDEP:
MassDEP File #:
eDEP Transaction #:1365251
City/Town:BOSTON

E. Fees

1. Fee Exempt: No filing fee shall be assessed for projects of any city, town, county, or district of the Commonwealth, federally recognized Indian tribe housing authority, municipal housing authority, or the Massachusetts Bay Transportation Authority.

Applicants must submit the following information (in addition to pages 1 and 2 of the NOI Wetland Fee Transmittal Form) to confirm fee payment:

<u>020214 & 020215</u>	<u>4/20/2022</u>
2. Municipal Check Number	3. Check date
<u>eDEP Filing Online Payment</u>	<u>4/20/2022</u>
4. State Check Number	5. Check date
<u>SWCA, Incorporated</u>	
6. Payer name on check: First Name	7. Payer name on check: Last Name

F. Signatures and Submittal Requirements

I hereby certify under the penalties of perjury that the foregoing Notice of Intent and accompanying plans, documents, and supporting data are true and complete to the best of my knowledge. I understand that the Conservation Commission will place notification of this Notice in a local newspaper at the expense of the applicant in accordance with the wetlands regulations, 310 CMR 10.05(5)(a).

I further certify under penalties of perjury that all abutters were notified of this application, pursuant to the requirements of M.G.L. c. 131, § 40. Notice must be made by Certificate of Mailing or in writing by hand delivery or certified mail (return receipt requested) to all abutters within 100 feet of the property line of the project location.

See Previous Sheet
1. Signature of Applicant

2. Date

See Previous Sheet
3. Signature of Property Owner (if different)

4. Date

See Previous Sheet
5. Signature of Representative (if any)

6. Date

For Conservation Commission:

Two copies of the completed Notice of Intent (Form 3), including supporting plans and documents, two copies of the NOI Wetland Fee Transmittal Form, and the city/town fee payment, to the Conservation Commission by certified mail or hand delivery.

For MassDEP:

One copy of the completed Notice of Intent (Form 3), including supporting plans and documents, one copy of the NOI Wetland Fee Transmittal Form, and a **copy** of the state fee payment to the MassDEP Regional Office (see Instructions) by certified mail or hand delivery.

Other:

If the applicant has checked the "yes" box in Section C, Items 1-3, above, refer to that section and the Instructions for additional submittal requirements.

The original and copies must be sent simultaneously. Failure by the applicant to send copies in a timely manner may result in dismissal of the Notice of Intent.

Massachusetts Department of Environmental Protection
 Bureau of Resource Protection - Wetlands
WPA Form 3 - Notice of Wetland Fee Transmittal
Form
 Massachusetts Wetlands Protection Act M.G.L. c. 131, §40

Provided by MassDEP:
 MassDEP File #:
 eDEP Transaction #:1365251
 City/Town: BOSTON

A. Applicant Information

1. Applicant:

a. First Name	DANIELLE	b. Last Name	MELLETT		
c. Organization	DEPARTMENT OF CONSERVATION AND RECREATION				
d. Mailing Address	251 CAUSEWAY STREET, SUITE 900				
e. City/Town	BOSTON	f. State	MA	g. Zip Code	02114
h. Phone Number		i. Fax		j. Email	danielle.mellett@state.ma.us

2. Property Owner:(if different)

a. First Name		b. Last Name			
c. Organization					
d. Mailing Address	CHARLES RIVER RESERVATION				
e. City/Town		f. State		g. Zip Code	
h. Phone Number		i. Fax		j. Email	

3. Project Location:

a. Street Address	CHARLES RIVER RESERVATION	b. City/Town	BOSTON
-------------------	---------------------------	--------------	--------

Are you exempted from Fee?

Note: Fee will be exempted if you are one of the following:

- City/Town/County/District
- Municipal Housing Authority
- Indian Tribe Housing Authority
- MBTA

State agencies are only exempt if the fee is less than \$100

B. Fees

Activity Type	Activity Number	Activity Fee	RF Multiplier	Sub Total
H.) CONTROL VEGETATION IN DEVELOPMENT;	1	500.00	RFA MULTIPLIER 1.5	750.00
		City/Town share of filling fee \$387.50	State share of filing fee \$362.50	Total Project Fee \$750.00



WPA Form 3 – Notice of Intent

Appendix A: Ecological Restoration Limited Project Checklists

Massachusetts Wetlands Protection Act M.G.L. c. 131, §40

Eligibility Checklist

This Ecological Restoration Limited Project Eligibility Checklist guides the applicant in determining if their project is eligible to file as an Inland or Coastal Ecological Restoration Limited Project (310 CMR 10.53(4) or 310 CMR 10.24(8) respectively). These criteria must be met when submitting the Ecological Restoration Limited Project Notice of Intent to ensure that the restoration and improvement of the natural capacity of a Resource Area(s) to protect and sustain the interests identified in the WPA is **necessary** to achieve the project's ecological restoration goals.

Important:
When filling out forms on the computer, use only the tab key to move your cursor - do not use the return key.



Note:
Before completing this form consult your local Conservation Commission regarding any municipal bylaw or ordinance.

Regulatory Features of All Coastal and Inland Ecological Restoration Limited Projects

- (a) May result in the temporary or permanent loss of or conversion of Resource Area: An Ecological Restoration Limited Project that meets the requirements of 310 CMR 10.24(8) may result in the temporary or permanent loss of Resource Areas and/or the conversion of one Resource Area to another when such loss is necessary to the achievement of the project's ecological restoration goals.
- (b) Exemption from wildlife habitat evaluation: A NOI for an Ecological Restoration Limited Project that meets the minimum requirements for Ecological Restoration Projects and for a MassDEP Combined Application outlined in 310 CMR 10.12(1) and (2) is exempt from providing a wildlife habitat evaluation (310 CMR 10.60).
- (c) The following are considerations for applicants filing an Ecological Restoration Limited Project NOI and for the issuing authority approving a project as an Ecological Restoration Limited Project:
 - The condition of existing and historic Resource Areas proposed for restoration.
 - Evidence of the extent and severity of the impairment(s) that reduce the capacity of the Resource Areas to protect and sustain the interests identified in M.G.L. c. 131, § 40.
 - The magnitude and significance of the benefits of the Ecological Restoration Project in improving the capacity of the affected Resource Areas to protect and sustain the other interests identified in M.G.L. c. 131, § 40.
 - The magnitude and significance of the impacts of the Ecological Restoration Project on existing Resource Areas that may be modified, converted and/or lost and the interests for which said Resource Areas are presumed significant in 310 CMR 10.00, and the extent to which the project will:
 - a. avoid adverse impacts to Resource Areas and the interests identified in M.G.L. c. 131, § 40, that can be avoided without impeding the achievement of the project's ecological restoration goals.
 - b. minimize adverse impacts to Resource Areas and the interests identified in M.G.L. c. 131, § 40, that are necessary to the achievement of the project's ecological restoration goals.
 - c. utilize best management practices such as erosion and siltation controls and proper construction sequencing to avoid and minimize adverse construction impacts to resource areas and the interests identified in M.G.L. c. 131, § 40.



WPA Form 3 – Notice of Intent

Appendix A: Ecological Restoration Limited Project Checklists

Massachusetts Wetlands Protection Act M.G.L. c. 131, §40

Eligibility Criteria - Coastal Ecological Restoration Limited Projects (310 CMR 10.24(8))

Provided by MassDEP:

MassDEP File Number

Document Transaction Number

Boston

City/Town

Complete this Eligibility Criteria Checklist **before** filling out a Notice of Intent Application to determine if your project qualifies as a Coastal Ecological Restoration Limited Project. (310 CMR 10.24(8)) Sign the Eligibility Certification at the end of Appendix A, and attach the checklist with supporting documentation and the Eligibility Certification to your Notice of Intent Application.

General Eligibility Criteria for All Coastal Ecological Restoration Limited Projects

Notwithstanding the requirements of 310 CMR 10.25 through 10.35, 310 CMR 10.54 through 10.58, and the Wildlife Habitat evaluations in 310 CMR 10.60, the Issuing Authority may issue an Order of Conditions permitting an Ecological Restoration Project listed in 310 CMR 10.24(8)(e) as an Ecological Restoration Limited Project and impose such conditions as will contribute to the interests identified in the WPA M.G.L. provided that the project meets all the requirements in 310 CMR 10.24(8).

- The project is an Ecological Restoration Project as defined in 310 CMR 10.04 and is a project type listed below [310 CMR 10.24(8)(e)].
- Tidal Restoration.
- Shellfish Habitat Restoration.
- Other Ecological Restoration Limited Project Type.
- The project will further at least one of the WPA (M.G.L. c. 131, § 40) interests identified below.
 - Protection of public or private water supply.
 - Protection of ground water supply.
 - Flood control.
 - Storm damage prevention.
 - Prevention of pollution.
 - Protection of land containing shellfish.
 - Protection of fisheries.
 - Protection of wildlife habitat.
- If the project will impact an area located within estimated habitat which is indicated on the most recent Estimated Habitat Map of State-Listed Rare Wetlands, a NHESP preliminary written determination is attached to the NOI submittal that the project will not have any adverse long-term and short-term effects on specified habitat sites of Rare Species or the project will be carried out in accordance with an approved NHESP habitat management plan.



WPA Form 3 – Notice of Intent

Appendix A: Ecological Restoration Limited Project Checklists

Massachusetts Wetlands Protection Act M.G.L. c. 131, §40

Eligibility Criteria - Coastal Ecological Restoration Limited Projects (310 CMR 10.24(8)) (Cont.)

Provided by MassDEP:

MassDEP File Number

Document Transaction Number

Boston
City/Town

General Eligibility Criteria for All Coastal Ecological Restoration Limited Projects (cont.)

- If the project is located in a Coastal Dune or Barrier Beach, the project avoids and minimizes armoring of the Coastal Dune or Barrier Beach to the maximum extent practicable.
- The project complies with all applicable provisions of 310 CMR 10.24(1) through (6) and 310 CMR 10.24(9) and (10).

Additional Eligibility Criteria for Specific Coastal Ecological Restoration Limited Project Types

These additional criteria must be met to qualify as an Ecological Restoration Limited Project to ensure that the restoration and improvement of the natural capacity of a Resource Area to protect and sustain the interests identified in the WPA is **necessary** to achieve the project's ecological restoration goals.

- This Ecological Restoration Limited Project application meets the eligibility criteria for Ecological Restoration Limited Project [310 CMR 10.24(8)(a) through (d) and as proposed, furthers at least one of the WPA interests is for the project type identified below.

Tidal Restoration Projects

- A project to restore tidal flow that will not significantly increase flooding or storm damage impacts to the built environment, including without limitation, buildings, wells, septic systems, roads or other man-made structures or infrastructure.

Shellfish Habitat Restoration Projects

- The project has received a Special Projects Permit from the Division of Marine Fisheries or, if a municipality, has received a shellfish propagation permit.
- The project is made of cultch (e.g., shellfish shells from oyster, surf or ocean clam) or is a structure manufactured specifically for shellfish enhancement (e.g., reef blocks, reef balls, racks, floats, rafts, suspended gear).

Other Ecological Restoration Projects that meet the criteria set forth in 310 CMR 10.24(8)(a) through (d).

- Restoration, enhancement, or management of Rare Species habitat.
- Restoration of hydrologic and habitat connectivity.
- Removal of aquatic nuisance vegetation to impede eutrophication.
- Thinning or planting of vegetation to improve habitat value.
- Fill removal and re-grading.
- Riparian corridor re-naturalization.
- River floodplain re-connection.



WPA Form 3 – Notice of Intent

Appendix A: Ecological Restoration Limited Project Checklists

Massachusetts Wetlands Protection Act M.G.L. c. 131, §40

Eligibility Criteria - Coastal Ecological Restoration Limited Projects (310 CMR 10.24(8)) (Cont.)

Additional Eligibility Criteria for Specific Coastal Ecological Restoration Limited Project Types

- In-stream habitat enhancement.
- Remediation of historic tidal wetland ditching.
- Eelgrass restoration.
- Invasive species management.
- Installation of fish passage structures.
- Other. Describe: _____
- This project involves the construction, repair, replacement or expansion of public or private infrastructure (310 CMR 10.24(9)).
 - The NOI attachment labeled _____ is an operation and maintenance plan to ensure that the infrastructure will continue to function as designed.
 - The operation and maintenance plan will be implemented as a continuing condition in the Order of Conditions and the Certificate of Compliance.
 - This project proposes to replace an existing stream crossing (310 CMR 10.24(10)). The crossing complies with the Massachusetts Stream Crossing Standards to the maximum extent practicable with details provided in the NOI. The crossing type:
 - Replaces an existing non-tidal crossing that is part of an Anadromous/Catadromous Fish Run (310 CMR 10.35)
 - Replaces an existing tidal crossing that restricts tidal flow. The tidal restriction will be eliminated to the maximum extent practicable.
 - At a minimum, in evaluating the potential to comply with the standards to the maximum extent practicable the following criteria have been consider site constraints in meeting the standard, undesirable effects or risk in meeting the standard, and the environmental benefit of meeting the standard compared to the cost, by evaluating the following:
 - The potential for downstream flooding;
 - Upstream and downstream habitat (in-stream habitat, wetlands);
 - Potential for erosion and head-cutting;
 - Stream stability;
 - Habitat fragmentation caused by the crossing;
 - The amount of stream mileage made accessible by the improvements;
 - Storm flow conveyance;



WPA Form 3 – Notice of Intent

Appendix A: Ecological Restoration Limited Project Checklists

Massachusetts Wetlands Protection Act M.G.L. c. 131, §40

Eligibility Criteria - Coastal Ecological Restoration Limited Projects (310 CMR 10.24(8)) (Cont.)

Additional Eligibility Criteria for Specific Coastal Ecological Restoration Limited Project Types

- Engineering design constraints specific to the crossing;
- Hydrologic constraints specific to the crossing;
- Impacts to wetlands that would occur by improving the crossing;
- Potential to affect property and infrastructure; and
- Cost of replacement.

Eligibility Criteria - Inland Ecological Restoration Limited Project (310 CMR 10.53(4))

Complete this Eligibility Criteria Checklist **before** filling out a Notice of Intent Application to determine if your project qualifies as an Inland Ecological Restoration Limited Project. (310 CMR 10.53(4)) Sign the Eligibility Certification at the end of Appendix A, and attach the checklist with supporting documentation and the Eligibility Certification to your Notice of Intent Application.

General Eligibility Criteria for All Inland Ecological Restoration Limited Projects

Notwithstanding the requirements of any other provision of 310 CMR 10.25 through 10.35, 310 CMR 10.54 through 10.58, and 310 CMR 10.60, the Issuing Authority may issue an Order of Conditions permitting an Ecological Restoration Project listed in 310 CMR 10.53(4)(e) as an Ecological Restoration Limited Project and impose such conditions as will contribute to the interests identified in M.G.L. c. 131, § 40, provided that:

- The project is an Ecological Restoration Project as defined in 310 CMR 10.04 and is a project type listed below [310 CMR 10.53(4)(e)].
 - Dam Removal
 - Freshwater Stream Crossing Repair and Replacement
 - Stream Daylighting
 - Tidal Restoration
 - Rare Species Habitat Restoration
 - Restoring Fish Passageways
 - Other (describe project type): Invasive Vegetation Management



WPA Form 3 – Notice of Intent
Appendix A: Ecological Restoration Limited
Project Checklists

Massachusetts Wetlands Protection Act M.G.L. c. 131, §40

Eligibility Criteria - Inland Ecological Restoration Limited Project (310
CMR 10.53(4)) (cont.)

Provided by MassDEP:

MassDEP File Number

Document Transaction Number

Boston

City/Town

General Eligibility Criteria for All Inland Ecological Restoration Limited Projects

- The project will further at least one of the WPA (M.G.L. c. 131, § 40) interests identified below.
 - Protection of public or private water supply
 - Protection of ground water supply
 - Flood control
 - Storm damage prevention
 - Prevention of pollution
 - Protection of land containing shellfish
 - Protection of fisheries
 - Protection of wildlife habitat
- If the project will impact an area located within estimated habitat which is indicated on the most recent Estimated Habitat Map of State-Listed Rare Wetlands, a NHESP preliminary written determination is attached to the NOI submittal that the project will have no adverse long-term and short-term effects on specified habitat sites of Rare Species or the project will be carried out in accordance with an approved NHESP habitat management plan.
- The project will be carried out in accordance with any time of year restrictions or other conditions recommended by the Division of Marine Fisheries for coastal waters and the Division of Fisheries and Wildlife in accordance with 310 CMR 10.11(3).
- If the project involves the dredging of 100 cubic yards of sediment or more or dredging of any amount in an Outstanding Resource Water, a Water Quality Certification has been applied for or obtained.
- The project complies with all applicable provisions of 310 CMR 10.53(1), (2), (7), and (8).



WPA Form 3 – Notice of Intent

Appendix A: Ecological Restoration Limited Project Checklists

Massachusetts Wetlands Protection Act M.G.L. c. 131, §40

Eligibility Criteria - Inland Ecological Restoration Limited Project (310 CMR 10.53(4)) (cont.)

Provided by MassDEP:

MassDEP File Number

Document Transaction Number

Boston

City/Town

Additional Eligibility Criteria for Specific Inland Ecological Restoration Limited Project Types

These additional criteria must be met to qualify as an Ecological Restoration Limited Project to ensure that the restoration and improvement of the natural capacity of a Resource Area to protect and sustain the interests identified in the WPA is **necessary** to achieve the project's ecological restoration goals.

This project application meets the eligibility criteria for Ecological Restoration Limited Project in accordance with [310 CMR 10.53(4)(a) through (d) and as proposed, furthers at least one of the WPA interests is for the project type identified below:

Dam Removal

Project is consistent with MassDEP's 2007 Dam Removal Guidance.

Freshwater Stream Crossing Repair and Replacement. The project as proposed and the NOI describes how:

Meeting the eligibility criteria set forth in 310 CMR 10.13 would result in significant stream instability or flooding hazard that cannot otherwise be mitigated, and site constraints make it impossible to meet said criteria.

The project design ensures that the stability of the bank is NOT impaired.

To the maximum extent practicable, the project provides for the restoration of the stream upstream and downstream of the structure as needed to restore stream continuity and eliminate barriers to aquatic organism movement.

The project complies with the requirements of 310 CMR 10.53(7) and (8).

Stream Daylighting Projects

The project meets the eligibility criteria for Ecological Restoration Limited Project [310 CMR 10.53(4)(a) through (d)] and as proposed the NOI describes how the proposed project meets to the maximum extent practicable, consistent with the project's ecological restoration goals, all the performance standards for Bank and Land Under Water Bodies and Waterways.

The project meets the requirements of 310 CMR 10.12(1) and (2) and a wildlife habitat evaluation is not included in the NOI.

Tidal Restoration Project

Restores tidal flow.

the project, including any proposed flood mitigation measures, will not significantly increase flooding or storm damage to the built environment, including without limitation, buildings, wells, septic systems, roads or other man-made structures or infrastructure.



WPA Form 3 – Notice of Intent

Appendix A: Ecological Restoration Limited Project Checklists

Massachusetts Wetlands Protection Act M.G.L. c. 131, §40

Eligibility Criteria - Inland Ecological Restoration Limited Project (310 CMR 10.53(4)) (cont.)

- Other Ecological Restoration Projects** that meet the criteria set forth in 310 CMR 10.53 (4) (a) through (d).
 - Restoration, enhancement, or management of Rare Species habitat.
 - Restoration of hydrologic and habitat connectivity.
 - Removal of aquatic nuisance vegetation to impede eutrophication.
 - Thinning or planting of vegetation to improve habitat value.
 - Riparian corridor re-naturalization.
 - River floodplain re-connection.
 - In-stream habitat enhancement.
 - Fill removal and re-grading.
 - Flow restoration.
 - Installation of fish passage structures.
 - Invasive species management.
 - Other. Describe: _____
- This project involves the construction, repair, replacement or expansion of public or private infrastructure. (310 CMR 10.53(7))
 - The NOI attachment labeled _____ is an operation and maintenance plan to ensure that the infrastructure will continue to function as designed.
 - The operation and maintenance plan will be implemented as a continuing condition in the Order of Conditions and the Certificate of Compliance.
- This project replaces an existing stream crossing (310 CMR 10.53(8)). The crossing type:
 - Replaces an existing non-tidal crossing designed to comply with the Massachusetts Stream Crossing Standards to the maximum extent practicable with details provided in the NOI.
 - Replaces an existing tidal crossing that restricts tidal flow. The tidal restriction will be eliminated to the maximum extent practicable.



WPA Form 3 – Notice of Intent
Appendix A: Ecological Restoration Limited
Project Checklists

Massachusetts Wetlands Protection Act M.G.L. c. 131, §40

Eligibility Criteria - Inland Ecological Restoration Limited Project (310
CMR 10.53(4)) (cont.)

Provided by MassDEP:

MassDEP File Number

Document Transaction Number

Boston

City/Town

- At a minimum, in evaluating the potential to comply with the standards to the maximum extent practicable the following criteria have been consider site constraints in meeting the standard, undesirable effects or risk in meeting the standard, and the environmental benefit of meeting the standard compared to the cost, by evaluating the following:
 - The potential for downstream flooding;
 - Upstream and downstream habitat (in-stream habitat, wetlands);
 - Potential for erosion and head-cutting;
 - Stream stability;
 - Habitat fragmentation caused by the crossing;
 - The amount of stream mileage made accessible by the improvements;
 - Storm flow conveyance;
 - Engineering design constraints specific to the crossing;
 - Hydrologic constraints specific to the crossing;
 - Impacts to wetlands that would occur by improving the crossing;
 - Potential to affect property and infrastructure; and
 - Cost of replacement.



Provided by MassDEP:
MassDEP File Number
Document Transaction Number

WPA Form 3 – Notice of Intent

Appendix A: Ecological Restoration Limited Project Checklists

Boston
City/Town

Massachusetts Wetlands Protection Act M.G.L. c. 131, §40 Required Actions (310 CMR 10.11)

Complete the Required Actions before submitting a Notice of Intent Application for an Ecological Restoration Project and submit a completed copy of this Checklist with the Notice of Intent.

Massachusetts Environmental Policy Act (MEPA) / Environmental Monitor
<https://www.mass.gov/service-details/the-environmental-monitor>

For Ecological Restoration Limited Projects, there are no changes to MEPA requirements.

Submit written notification at least 14 days prior to the filing of a Notice of Intent (NOI) to the Environmental Monitor for publication. A copy of the written notification is attached and provides at minimum:

- A brief description of the proposed project.
- The anticipated NOI submission date to the conservation commission.
- The name and address of the conservation commission that will review the NOI.
- Specific details as to where copies of the NOI may be examined or acquired and where to obtain the date, time, and location of the public hearing.

Massachusetts Endangered Species Act (MESA) /Wetlands Protection Act Review

Preliminary Massachusetts Endangered Species Act Review from the Natural Heritage and Endangered Species Program (NHESP) has been met and the written determination is attached.

Supplemental Information for Endangered Species Review has been submitted.

1. Percentage/acreage of property to be altered:

a. Within Wetland Resource Area _____
Percentage/acreage

b. Outside Wetland Resource Area _____
Percentage/acreage

2. Assessor’s Map or right-of-way plan of site

3. Project plans for entire project site, including wetland resource areas and areas outside of wetlands jurisdiction, showing existing and proposed conditions, existing and proposed tree/vegetation clearing line, and clearly demarcated limits of work.

4. Project description (including description of impacts outside of wetland resource area & buffer zone)

5. Photographs representative of the site

6. MESA filing fee (fee information available at <https://www.mass.gov/how-to/how-to-file-for-a-mesa-project-review>)



WPA Form 3 – Notice of Intent

Appendix A: Ecological Restoration Limited Project Checklists

Massachusetts Wetlands Protection Act M.G.L. c. 131, §40
Required Actions (310 CMR 10.11) (cont.)

Provided by MassDEP:
MassDEP File Number
Document Transaction Number
Boston
City/Town

Make check payable to “Commonwealth of Massachusetts - NHESP” and mail to NHESP:

Natural Heritage & Endangered Species Program

MA Division of Fisheries & Wildlife
1 Rabbit Hill Road
Westborough, MA 01581

- 7. Projects altering 10 or more acres of land, also submit:
 - a. Vegetation cover type map of site
 - b. Project plans showing Priority & Estimated Habitat boundaries

OR Check One of the Following:

- 1. Project is exempt from MESA review.

Attach applicant letter indicating which MESA exemption applies. (See 321 CMR 10.14, <https://www.mass.gov/service-details/ma-endangered-species-act-mesa-overview>; the NOI must still be sent to NHESP if the project is within estimated habitat pursuant to 310 CMR 10.37 and 10.59 – see C4 below)

- 2. Separate MESA review ongoing.

a. NHESP Tracking # _____

b. Date submitted to NHESP _____

- 3. Separate MESA review completed. Include copy of NHESP “no Take” determination or valid Conservation & Management Permit with approved plan.

Estimated Habitat Map of State-Listed Rare Wetlands Wildlife

If a portion of the proposed project is located in **Estimated Habitat of Rare Wildlife** as indicated on the most recent Estimated Habitat Map of State-Listed Rare Wetland Wildlife published by the Natural Heritage and Endangered Species Program (NHESP), complete the portion below. To view habitat maps, see the **Massachusetts Natural Heritage Atlas** or view the maps electronically at: <https://www.mass.gov/guides/masswildlife-publications#-massachusetts-natural-heritage-atlas->

- A preliminary written determination from Natural Heritage and Endangered Species Program (NHESP) must be obtained indicating that:
 - Project will NOT have long- or short-term adverse effect on the actual Resource Area located within estimated habitat indicated on the most recent Estimated Habitat Map of State-Listed Rare Wetlands Wildlife published by NHESP.
 - Project will have long- or short-term adverse effect on the actual Resource Area located within estimated habitat indicated on the most recent Estimated Habitat Map of State-Listed Rare Wetlands Wildlife published by NHESP. A copy of NHESP’s written preliminary determination in accordance with 310 CMR 10.11(2) is attached. This specifies:

Date of the map: _____



WPA Form 3 – Notice of Intent

Appendix A: Ecological Restoration Limited Project Checklists

Massachusetts Wetlands Protection Act M.G.L. c. 131, §40

Required Actions (310 CMR 10.11) (cont.)

Provided by MassDEP:

MassDEP File Number

Document Transaction Number

Boston
City/Town

- If the Rare Species identified is/are likely to continue to be located on or near the project, and if so, whether the Resource Area to be altered is in fact part of the habitat of the Rare Species.
- That if the project alters Resource Area(s) within the habitat of a Rare Species:
- The Rare Species is identified;
- NHESP's recommended changes or conditions necessary to ensure that the project will have no short or long term adverse effect on the habitat of the local population of the Rare Species is provided; or
- An approved NHESP habitat management plan is attached with this Notice of Intent.

Send the request for a preliminary determination to:
Natural Heritage & Endangered Species Program
MA Division of Fisheries & Wildlife
1 Rabbit Hill Road
Westborough, MA 01581

Division of Marine Fisheries

- If the project will occur within a coastal waterbody with a restricted Time of Year, [see Appendix B of the Division of Marine Fisheries (DMF) Technical Report TR 47 "Marine Fisheries Time of Year Restrictions (TOYs) for Coastal Alteration Projects" dated April 2011 <https://www.nae.usace.army.mil/Portals/74/docs/regulatory/StateGeneralPermits/MA/TR-47.pdf>].
- Obtain a DMF written determination stating:
 - The proposed work does NOT require a TOY restriction.
 - The proposed work requires a TOY restriction. Specific recommended TOY restriction and recommended conditions on the proposed work is attached.
- If the project may affect a diadromous fish run [re: Division of Marine Fisheries (DMF) Technical Reports TR 15 through 18, dated 2004: <https://www.mass.gov/service-details/marine-fisheries-technical-reports>]
- Obtain a DMF written determination stating:
 - The design specifications and operational plan for the project are compatible with the passage requirements of the fish run.
 - The design specifications and operational plan for the project are not compatible with the passage requirements of the fish run.



WPA Form 3 – Notice of Intent

Appendix A: Ecological Restoration Limited Project Checklists

Massachusetts Wetlands Protection Act M.G.L. c. 131, §40

Required Actions (310 CMR 10.11) (cont.)

Provided by MassDEP:
MassDEP File Number
Document Transaction Number

Boston
City/Town

Send the request for a written or electronic determination to:

South Shore – Cohasset to Rhode Island border,
and the Cape & Islands:
Division of Marine Fisheries –
South Coast Field Station
Attn: Environmental Reviewer
836 South Rodney French Blvd.
New Bedford, MA 02744
Email: DMF.EnvReview-South@state.ma.us

North Shore – Hull to New Hampshire border:
Division of Marine Fisheries –
North Shore Field Station
Attn: Environmental Reviewer
30 Emerson Avenue
Gloucester, MA 01930
Email: DMF.EnvReview-North@state.ma.us

- Division of Fisheries and Wildlife** – <https://www.mass.gov/orgs/division-of-fisheries-and-wildlife>
 - Projects that involve silt-generating, in-water work that will impact a non-tidal perennial river or stream and the in-water work will not occur between May 1 and August 30.
 - Obtain a written determination from the Division of Fisheries and Wildlife (DFW) as to whether the proposed work requires a TOY restriction.
 - The proposed work does NOT require a TOY restriction.
 - The proposed work requires a TOY restriction. The DFW determination with TOY restriction and other conditions is attached.

MassDEP Water Quality Certification

- Project involves dredging of 100 cubic yards or more in a Resource Area or dredging of any amount in an Outstanding Resource Water (ORW). A copy and proof of the MassDEP Water Quality Certification pursuant to 314 CMR 9.00 is attached to the NOI.
- This project is a Combined Permit Application for 401 Dredging and Restoration (BRP WW 26).

MassDEP Wetlands Restriction Order

Is any portion of the site subject to a Wetlands Restriction Order under the Inland Wetlands Restriction Act (M.G.L. c. 131, § 40A) or the Coastal Wetlands Restriction Act (M.G.L. c. 130, § 105)?

Yes No

Department of Conservation and Recreation

Office of Dam Safety

- For Dam Removal Projects, obtain a written determination from the Department of Conservation and Recreation Office of Dam Safety that the dam is not subject to the jurisdiction of the Office under 302 CMR 10.00, a written determination that the dam removal does not require a permit under 302 CMR 10.00 or a permit authorizing the dam removal in accordance with 302 CMR 10.00 has been issued.



WPA Form 3 – Notice of Intent

Appendix A: Ecological Restoration Limited Project Checklists

Massachusetts Wetlands Protection Act M.G.L. c. 131, §40 Required Actions (310 CMR 10.11) (cont.)

Areas of Critical Environmental Concern (ACECs)

Is any portion of the proposed project within an Area of Critical Environmental Concern (ACEC)?

Yes No

If yes, provide name of ACEC (see instructions to WPA Form 3 or MassDEP Website for ACEC locations).

Name of ACEC

Minimum Required Documents (310 CMR 10.12)

Complete the Required Documents Checklist below and provide supporting materials before submitting a Notice of Intent Application for an Ecological Restoration Project.

This Notice of Intent meets all applicable requirements outlined in for Ecological Restoration Projects in 310 CMR 10.12. Use the checklist below to ensure that all documentation is included with the NOI.

At a minimum, a Notice of Intent for an Ecological Restoration Project shall include the following:

- Description of the project’s ecological restoration goals;
- The location of the Ecological Restoration Project;
- Description of the construction sequence for completing the project;
- A map of the Areas Subject to Protection Under M.G.L. c. 131, § 40, that will be temporarily or permanently altered by the project or include habitat for Rare Species, Habitat of Potential Regional and Statewide Importance, eel grass beds, or Shellfish Suitability Areas.
- The method for BVW and other resource area boundary delineations (MassDEP BVW Field Data Form(s), Determination of Applicability, Order of Resource Area Delineation, etc.) is attached with documentation methodology.
- List the titles and dates for all plans and other materials submitted with this NOI.

Figures 1 through 8	
a. Plan Title	_____
SWCA Environmental Consultants	_____
b. Prepared by	c. Signed and Stamped by
2/23/22	_____
d. Final Revision Date	e. Scale
_____	_____
f. Additional Plan or Document Title	g. Date

- If there is more than one property owner, attach a list of these property owners not listed on this form.
- Attach NOI Wetland Fee Transmittal Form.



WPA Form 3 – Notice of Intent

Appendix A: Ecological Restoration Limited Project Checklists

Massachusetts Wetlands Protection Act M.G.L. c. 131, §40

Minimum Required Documents (310 CMR 10.12)

Provided by MassDEP:

MassDEP File Number

Document Transaction Number

Boston

City/Town

- An evaluation of any flood impacts that may affect the built environment, including without limitation, buildings, wells, septic systems, roads or other man-made structures or infrastructure as well as any proposed flood impact mitigation measures;
- A plan for invasive species prevention and control;
- The Natural Heritage and Endangered Species Program written determination in accordance with 310 CMR 10.11(2), if needed;
- Any Time of Year restrictions and/or other conditions recommended by the Division of Marine Fisheries or the Division of Fisheries and Wildlife in accordance with 310 CMR 10.11(3), (4), (5), if needed;
- Proof that notice was published in the Environmental Monitor as required by 310 CMR 10.11(1);
- A certification by the applicant under the penalties of perjury that the project meets the eligibility criteria set forth in 310 CMR 10.13;
- If the Ecological Restoration Project involves the construction, repair, replacement or expansion of infrastructure, an operation and maintenance plan to ensure that the infrastructure will continue to function as designed;
- If the project involves dredging of 100 cubic yards or more or dredging of any amount in an Outstanding Resource Water, a Water Quality Certification issued by the Department pursuant to 314 CMR 9.00;
- If the Ecological Restoration Project involves work on a stream crossing, information sufficient to make the showing required by 310 CMR 10.24(10) for work in a coastal resource area and 310 CMR 10.53(8) for work in an inland resource area; and
- If the Ecological Restoration Project involves work on a stream crossing, baseline photo-points that capture longitudinal views of the crossing inlet, the crossing outlet and the upstream and downstream channel beds during low flow conditions. The latitude and longitude coordinates of the photo-points shall be included in the baseline data.
- This project is subject to provisions of the MassDEP Stormwater Management Standards. A copy of the Stormwater Report as required by the Stormwater Management Standards per 310 CMR 10.05(6)(k)-(q) is attached.
- Provide information as to whether the project has the potential to impact private water supply wells including agricultural or aquacultural wells or surface water withdrawal points.



Massachusetts Department of Environmental Protection
Bureau of Resource Protection - Wetlands

WPA Form 3 – Notice of Intent
Appendix A: Ecological Restoration Limited
Project Checklists

Massachusetts Wetlands Protection Act M.G.L. c. 131, §40

Provided by MassDEP:
MassDEP File Number
Document Transaction Number

Boston
City/Town

Certification that the Ecological Restoration Project Meets the Eligibility Criteria

I hereby certify under penalties of perjury that the Ecological Restoration Project Notice of Intent application does not meet the Eligibility criteria for an Ecological Restoration Order of Conditions set forth in 310 CMR 10.13, but does meet the Eligibility Criteria for a Ecological Restoration Limited Project set forth in 10.24(8) or 10.53(4) whichever is applicable. I certify that I am familiar with the information contained in the application, and that to the best of my knowledge and belief such information is true, complete, and accurate. I further certify that I possess the authority to undertake the proposed activities.

Signature of Applicant or Authorized Agent

Danielle Mellett

Printed Name of Applicant or Authorized Agent

4/12/22

Date

The certification must be signed by the applicant; however, it may be signed by a duly authorized agent (named in Item 2) if this form is accompanied by a statement by the applicant designating the agent and agreeing to furnish upon request, supplemental information in support of the application.



INSTRUCTIONS FOR COMPLETING APPLICATION NOTICE OF INTENT – BOSTON NOI FORM

The Boston Notice of Intent Form is intended to be a supplement to the WPA Form 3 detailing impacts to locally designated wetland resource areas and buffer zones. Please read these instructions for assistance in completing the Notice of Intent application form. These instructions cover certain items on the Notice of Intent form that are not self-explanatory.

INSTRUCTIONS TO SECTION B: BUFFER ZONE AND RESOURCE AREA IMPACTS

Item 1. Buffer Zone Only. If you check the Buffer Zone Only box in this section you are indicating that the project is entirely in the Buffer Zone to a resource area **under both** the Wetlands Protection Act and Boston Wetlands Ordinance. If so, skip the remainder of Section B and go directly to Section C. Do not check this box if the project is within the Waterfront Area.

Item 2. The **boundaries of coastal resource areas** specific to the Ordinance can be found in Section II of the Boston Wetlands Regulations. You must also include the size of the proposed alterations (and proposed replacement areas) in each resource area.

Item 3. The **boundaries of inland resource areas** specific to the Ordinance can be found in Section II of the Boston Wetlands Regulations. You must also include the size of the proposed alterations (and proposed replacement areas) in each resource area.

INSTRUCTIONS TO SECTION C: OTHER APPLICABLE STANDARDS AND REQUIREMENTS

Item 1. Rare Wetland Wildlife Habitat. Except for Designated Port Areas, no work (including work in the Buffer Zone) may be permitted in any resource area that would have adverse effects on the habitat of rare, "state-listed" vertebrate or invertebrate animal species.

The most recent Estimated Habitat Map of State-Listed Rare Wetland Wildlife is published by the Natural Heritage and Endangered Species Program (NHESP). See: http://maps.massgis.state.ma.us/PRI_EST_HAB/viewer.htm or the *Massachusetts Natural Heritage Atlas*.

If any portion of the proposed project is located within Estimated Habitat, the applicant must send the Natural Heritage Program, at the following address, a copy of the Notice of Intent by certified mail or priority mail (or otherwise sent in a manner that guarantees delivery within two days), no later than the date of the filing of the Notice of Intent with the Conservation Commission.

Evidence of mailing to the Natural Heritage Program (such as Certified Mail Receipt or Certificate of Mailing for Priority Mail) must be submitted to the Conservation Commission along with the Notice of Intent.

Natural Heritage and Endangered Species Program
Division of Fisheries and Wildlife
1 Rabbit Hill Road
Westborough, MA 01581-3336
508.792.7270



A. GENERAL INFORMATION

1. Project Location

<u>Charles River Reservation</u>	<u>Boston</u>	<u>02215</u>
a. Street Address	b. City/Town	c. Zip Code
<u>None Listed</u>	<u>2203416000; 2202748000; 2200577000 ; 2200470000; 2200302000;</u>	
f. Assessors Map/Plat Number	<u>2200103000; 0503747000; 2100370000; 0502498000; 0300943000</u>	
	g. Parcel /Lot Number	

2. Applicant

<u>Danielle</u>	<u>Mellett</u>	<u>Department of Conservation and Recreation</u>
a. First Name	b. Last Name	c. Company
<u>251 Causeway Street, Suite 900</u>		
d. Mailing Address		
<u>Boston</u>	<u>MA</u>	<u>02114</u>
e. City/Town	f. State	g. Zip Code
<u></u>	<u></u>	<u>danielle.mellett@mass.gov</u>
h. Phone Number	i. Fax Number	j. Email address

3. Property Owner

<u></u>	<u></u>	<u>Department of Conservation and Recreation</u>
a. First Name	b. Last Name	c. Company
<u>251 Causeway Street, Suite 900</u>		
d. Mailing Address		
<u>Boston</u>	<u>MA</u>	<u>02114</u>
e. City/Town	f. State	g. Zip Code
<u></u>	<u></u>	<u></u>
h. Phone Number	i. Fax Number	j. Email address

Check if more than one owner

(If there is more than one property owner, please attach a list of these property owners to this form.)

4. Representative (if any)

<u>Naomi</u>	<u>Valentine</u>	<u>SWCA Environmental Consultants</u>
a. First Name	b. Last Name	c. Company
<u>15 Research Drive</u>		
d. Mailing Address		
<u>Amherst</u>	<u>MA</u>	<u>01002</u>
e. City/Town	f. State	g. Zip Code
<u>413.658.2012</u>	<u></u>	<u>nvalentine@swca.com</u>
h. Phone Number	i. Fax Number	j. Email address



5. Is any portion of the proposed project jurisdictional under the Massachusetts Wetlands Protection Act M.G.L. c. 131 §40?

- Yes No

If yes, please file the WPA Form 3 - Notice of Intent with this form

6. General Information

The proposed project is for the updated Charles River Vegetation Management Plan, which includes the continuation of routine maintenance of the Charles River Reservation (lands, landscaped areas, green infrastructure, structures, circulation, woodland, meadow and river's edge), continued vegetation management for annual special events, and proposed invasive plant management in four specific focus areas within the Boston portion of the Reservation.

7. Project Type Checklist

- a. Single Family Home
- b. Residential Subdivision
- c. Limited Project Driveway Crossing
- d. Commercial/Industrial
- e. Dock/Pier
- f. Utilities
- g. Coastal Engineering Structure
- h. Agriculture – cranberries, forestry
- i. Transportation
- j. Other

8. Property recorded at the Registry of Deeds

<u>Suffolk County</u>	
a. County	b. Page Number
c. Book	d. Certificate # (if registered land)

9. Total Fee Paid

<u>\$2,156.25</u>	<u>\$356.25</u>	<u>\$1,800.00</u>
a. Total Fee Paid	b. State Fee Paid	c. City Fee Paid

B. BUFFER ZONE & RESOURCE AREA IMPACTS

Buffer Zone Only - Is the project located only in the Buffer Zone of a resource area protected by the Boston Wetlands Ordinance?

- Yes No

1. Coastal Resource Areas



<u>Resource Area</u>	<u>Resource Area Size</u>	<u>Proposed Alteration*</u>	<u>Proposed Mitigation</u>
<input type="checkbox"/> Coastal Flood Resilience Zone	_____ Square feet	_____ Square feet	_____ Square feet
<input type="checkbox"/> 25-foot Waterfront Area	_____ Square feet	_____ Square feet	_____ Square feet
<input type="checkbox"/> 100-foot Salt Marsh Area	_____ Square feet	_____ Square feet	_____ Square feet
<input type="checkbox"/> Riverfront Area	_____ Square feet	_____ Square feet	_____ Square feet

2. Inland Resource Areas

<u>Resource Area</u>	<u>Resource Area Size</u>	<u>Proposed Alteration*</u>	<u>Proposed Mitigation</u>
<input type="checkbox"/> Inland Flood Resilience Zone	_____ Square feet	_____ Square feet	_____ Square feet
<input checked="" type="checkbox"/> Isolated Wetlands	<u>11,850</u> Square feet	<u>7,819</u> Square feet	_____ Square feet
<input type="checkbox"/> Vernal Pool	_____ Square feet	_____ Square feet	_____ Square feet
<input type="checkbox"/> Vernal Pool Habitat (vernal pool + 100 ft. upland area)	_____ Square feet	_____ Square feet	_____ Square feet
<input checked="" type="checkbox"/> 25-foot Waterfront Area	<u>2,344,834</u> Square feet	<u>80,590</u> Square feet	_____ Square feet
<input checked="" type="checkbox"/> Riverfront Area	<u>2,452,864</u> Square feet	<u>118,022</u> Square feet	_____ Square feet

C. OTHER APPLICABLE STANDARDS & REQUIREMENTS

1. What other permits, variances, or approvals are required for the proposed activity described herein and what is the status of such permits, variances, or approvals?

Orders of Conditions are needed in the three other municipalities (Cambridge, Watertown, and Newton) within the Charles River Reservation (South Basin). No other permits are required for this vegetation management plan.



2. Is any portion of the proposed project located in Estimated Habitat of Rare Wildlife as indicated on the most recent Estimated Habitat Map of State-Listed Rare Wetland Wildlife published by the Natural Heritage and Endangered Species Program (NHESP)? To view habitat maps, see the Massachusetts Natural Heritage Atlas or go to <http://www.mass.gov/dfwele/dfw/nhosp/nhregmap.htm>.
- Yes No

If yes, the project is subject to Massachusetts Endangered Species Act (MESA) review (321 CMR 10.18).

A. Submit Supplemental Information for Endangered Species Review

- Percentage/acreage of property to be altered:
- (1) within wetland Resource Area _____ percentage/acreage
- (2) outside Resource Area _____ percentage/acreage
- Assessor's Map or right-of-way plan of site

3. Is any portion of the proposed project within an Area of Critical Environmental Concern?
- Yes No

If yes, provide the name of the ACEC: _____

4. Is the proposed project subject to provisions of the Massachusetts Stormwater Management Standards?
- Yes. Attach a copy of the Stormwater Checklist & Stormwater Report as required.
 - Applying for a Low Impact Development (LID) site design credits
 - A portion of the site constitutes redevelopment
 - Proprietary BMPs are included in the Stormwater Management System
 - No. Check below & include a narrative as to why the project is exempt
 - Single-family house
 - Emergency road repair
 - Small Residential Subdivision (less than or equal to 4 single family houses or less than or equal to 4 units in a multifamily housing projects) with no discharge to Critical Areas

5. Is the proposed project subject to Boston Water and Sewer Commission Review?
- Yes No



D. SIGNATURES AND SUBMITTAL REQUIREMENTS

I hereby certify under the penalties of perjury that the foregoing Notice of Intent and accompanying plans, documents, and supporting data are true and complete to the best of my knowledge. I understand that the Conservation Commission will place notification of this Notice in a local newspaper at the expense of the applicant in accordance with the Wetlands Protection Ordinance.

Signature of Applicant

4/12/22

Date

Signature of Property Owner (if different)

4/12/22

Date

Naomi Valentine

Digitally signed by Naomi Valentine
Date: 2022.04.12 10:25:40 -04'00'

Signature of Representative (if any)

4/12/22

Date

CHARLES RIVER VEGETATION MANAGEMENT PLAN NOTICE OF INTENT SUBMITTAL

Prepared on Behalf of

Danielle Mellett
Massachusetts Department of Conservation and Recreation
251 Causeway Street
Boston, Massachusetts 02114

Prepared by

SWCA Environmental Consultants
15 Research Drive
Amherst, Massachusetts 01002
(413) 256-0202
www.swca.com

SWCA Project No. 70690-000-AMH

May 2022

CONTENTS

1	Introduction	1
2	Site Description.....	2
2.1	Routine Vegetation Management Landscape Types	3
2.1.1	Tree Management	4
2.2	Special Event Area Descriptions	5
2.2.1	Head of the Charles Regatta	5
2.2.2	Fourth of July Celebration	5
2.3	Invasive Plant Focus Areas.....	5
3	Regulated Wetland Resource Areas	6
3.1	Inland Bank (310 CMR 10.54)	7
3.2	Bordering Vegetated Wetland (310 CMR 10.55).....	8
3.3	Bordering Land Subject to Flooding (310 CMR 10.57).....	9
3.4	Riverfront Area (310 CMR 10.58)	9
3.5	Isolated Vegetated Wetland (Ordinance).....	9
3.6	Waterfront Area (Ordinance).....	10
3.7	Buffer Zone.....	10
4	Other Environmental Constraints	10
5	Proposed Work.....	11
5.1	Routine Maintenance.....	11
5.2	Specific Vegetation Management.....	12
5.3	Restoration Goals	15
5.3.1	Ecological Restoration Limited Project Context	16
5.4	Proposed Impact Calculations	17
6	General Provisions and Performance Standards Review	17
6.1	Bank (310 CMR 10.54(4)).....	18
6.2	Bordering Vegetated Wetland (310 CMR 10.55(4))	19
6.3	Bordering Land Subject to Flooding (310 CMR 10.57(4)(a)).....	20
6.4	Riverfront Area (310 CMR 10.58(4)).....	21
6.5	Isolated Vegetated Wetlands (Boston Wetland Regulations, Section XIV.D.).....	21
7	Avoidance, Minimization, and Restoration.....	23
7.1	General Minimization Strategies	23
7.2	Special Events River’s Edge Trimming	24
7.3	Invasive Plant Management.....	24
8	Summary	25
9	Literature Cited.....	25

Appendices

- Appendix A. Supporting Materials
- Appendix B. Abutter Notification Letters
- Appendix C. Figures
- Appendix D. Site Photographs
- Appendix E. Landscape Type and Restoration Specifications
- Appendix F. Invasive Plant Management Details
- Appendix G. Spill Prevention Plan

Tables

Table 1. Routine Maintenance Landscape Types within the Project Area	4
Table 2. Invasive Plant Focus Areas (west to east-northeast).....	6
Table 3. Types of Vegetation Management within Jurisdictional Resource Areas	7
Table 4. Summary of Prescribed Management Activities by Routine Maintenance Landscape Type	11
Table 5. Total Resource Area Impacts within Vegetation Management Types.....	12
Table 6. Specific Vegetation Management Details*.....	13
Table 7. Impact Calculations within Specific Vegetation Management Areas.....	15
Table 8. Restoration Goals.....	16
Table 9. Resource Area Impact Calculations.....	17
Table 10. General Provisions of all Wetlands and Inland Wetlands (310 CMR 10.03 and 10.53)	17

1 INTRODUCTION

SWCA Environmental Consultants (SWCA) has prepared this Notice of Intent (NOI) on behalf of the Massachusetts Department of Conservation and Recreation (DCR) to implement the Charles River Vegetation Management Plan (CRVMP) along the southern bank of the Charles River in Boston, Massachusetts (the project). Specifically, the project area is located between the [Newton Yacht Club and North Point Park](#). This is part of a greater CRVMP project, which spans various sections of bank and adjacent DCR properties within Boston, Cambridge, Watertown, and Newton. DCR has established the following goals for the CRVMP:

1. Ensure all routine maintenance is carried out in a manner that has no potential for damage to the environment and all vegetation management activities will be performed to avoid and minimize any potential impacts to the maximum extent practicable.
2. Restore the natural capacity of the *existing* Wetland Resource Areas to protect and sustain the interests identified in the Massachusetts Wetlands Protection Act (M.G.L. c. 131, § 40) (WPA) and the City of Boston Wetland Protection and Climate Change Adaptation Ordinance (Sec. 7-1.4) (the Ordinance) and provide for stable and sustainable shorelines; historic vistas; climate resiliency; and a safe, stable tree canopy.
 - a. [Climate change is being considered in the following ways in this filing:](#)
 - i. [Increasing the resilience of the riparian zone through native vegetation installation, invasive plant management, slope stabilization, and higher resilience increased stormwater inputs through phase-based restoration.](#)
 - ii. [Program to increase resilience arboriculture practices and native tree replacement.](#)
 - iii. [Prioritization to convert underutilized lawn space to open meadow.](#)
3. Develop strategies that protect the properties' ecological, recreational and cultural integrity and consistently implement such strategies across all public/private uses of the property (leases, [Memorandums of Agreement [MOAs], special use permits, easements, etc.).
4. Provide public access to outstanding opportunities for passive and active recreation along and adjacent to the riverbank.
5. Steward parklands that reflect the cultural value and 100-year history of the Charles River Reservation.
6. Engage a cooperative network of parkland stakeholders who both enjoy the many recreational opportunities and provide volunteer assistance in managing the CRVMP area.
7. Provide a framework to guide future capital restoration projects.

This NOI has been developed in accordance with the WPA and its implementing regulations (310 Code of Massachusetts Regulations [CMR] 10.00 et seq.), and the Ordinance. The proposed project is filed as an Ecological Restoration Limited Project under 310 CMR 10.53(4). The Ecological Restoration Limited Project Checklist (WPA Form 3 Appendix A) is included at the beginning of this filing. The Charles River Reservation was created within filled tidelands and has since been altered with ornamental plantings (many of which are now considered invasive), lawn and meadow areas, and infrastructure that require maintenance for safe and accessible recreational use. However, the goals of this project are to improve all resources to the extent practicable and restore a more resilient native vegetative community

over time. The proposed project also meets the definition of a Resource Area Enhancement project under Ch. 7-1.4(b) of the Ordinance¹.

The proposed project seeks to manage vegetation within the following resource areas jurisdictional under the WPA: Bank, including the associated 100-foot buffer zone; Bordering Vegetated Wetland (BVW), including the associated 100-foot buffer zone; Bordering Land Subject to Flooding (BLSF); and 25-foot Riverfront Area (RFA). The project area also includes resource areas that are jurisdictional under the Ordinance, including Isolated Vegetated Wetlands (IVW) with associated buffer zone and Waterfront Area. The three types of vegetation management proposed within these resource areas include: 1) routine maintenance; 2) specific vegetation management, including management for special events and invasive and nuisance plants; and 3) restoration (see Section 5). All wetland resource areas within the project area are designated as inland resources, as this section of the Charles River is not tidally influenced. The Boston Conservation Commission has previously accepted all wetland delineations in the Charles River Reservation as inland wetland delineations. All impacts are temporary in nature and no adverse impact will occur to any of the resource areas within or near the project work area (see Section 3).

The proposed project is not subject to the MassDEP Stormwater Standards, as there will be no impact to the existing land's ability to manage stormwater. Furthermore, the restoration planned for the riparian zone and other portions of the Reservation will increase stormwater damage prevention. Where vegetation management occurs, DCR will implement best management practices (BMPs) to ensure that the land's capacity to manage stormwater remains intact. These BMPs are included in this filing below.

Two hard copies and a digital copy of this NOI and associated documents have been submitted to the Boston Conservation Commission. The NOI application and documents have also been filed with the Massachusetts Department of Environmental Protection (DEP) using the eDEP online filing site.

This project is being filed under Category 2h, which includes a fee of \$237.50 to the state. As this project is within the RFA, this fee is multiplied by 1.5 for a total state fee of \$356.25. The Boston Conservation Commission waives their right to the municipal portion of the WPA fee in lieu of their own local filing fees. The local filing fee is calculated as \$300 for Category 2 and \$1,500 for projects with the fair cost of more than \$10,000. Copies of the filing fee checks are included in Appendix A.

Since the project area is a continuous tract of land composed of multiple parcels, some greater than 50 acres, SWCA has notified abutters within 300 feet of the project area, including those in neighboring municipalities and across waterbodies (Ordinance Section Ch. 7-1.4(b)² and (f)). Abutter notification letters were sent in both English and the second most commonly spoken language in the neighborhoods within the project area ([English and Chinese](#)). [Additionally the Babel Notice has been sent to all 300-foot project abutters](#). Appendix B includes a list of certified abutters and a copy of the notification letter.

2 SITE DESCRIPTION

The CRVMP project area in Boston extends from Daly Field to [the Boston portion of North Point Park](#) (Figure C1). Project activities will be completed within the Charles River Reservation, specifically in the riparian area where the terrestrial portions of the parkland meet the Charles River, and immediately

¹ Removal or management of invasive species; removal of debris, garbage, or trash; restoration and/or stabilization of bank or other resource area; planting or management of non-invasive species of vegetation...

² Abutter. The owner of any lot within 300 feet of the property line where the activity is proposed... [including] the owner... who may be in another municipality or across a body of water... When work is... on a tract of land greater than 50 acres, then written notification must be given only to abutters within 300 feet of the project site."

adjacent parklands. The full project area consists of approximately 135.9 acres of land. Figures of the project area are included in Appendix C. Site photographs are included in Appendix D.

The Charles River Reservation provides a vibrant mixture of recreational resources serving adjacent urban neighborhoods and institutions as well as visitors from the metropolitan area and beyond. The banks of the river support a wide range of activities from lawn sports, picnicking, sunbathing, scenic walks, and dog walking to playgrounds, wading pools, tennis courts, and athletic fields. The 18-mile Dr. Paul Dudley White Bicycle Path is used for distance biking, commuting, inline skating, running and walking, as well as road races and walkathons. The river itself supports sailing, rowing, yachting, canoeing, kayaking, boat tours, and fishing.

A vegetative riparian buffer separates the Charles River from the passive recreation areas that include recreational and public use lawns, bikeways, natural surface trails, buildings, parking lots, and other park infrastructure. The vegetative buffer is mainly comprised of scattered pockets of dense vegetation including trees, shrubs, grasses, wildflowers, and vines. Soils are compacted and the vegetation is frequently disturbed by anthropogenic changes in water level, extreme weather events, and recreational activities on the land and water. As a result, the predominant vegetative layer is populated by non-native nuisance species such as false indigo (*Amorpha fruticosa*) and mugwort (*Artemisia vulgaris*), and non-native invasive plant species such as tree of heaven (*Ailanthus altissima*), common reed (*Phragmites australis*), shrub honeysuckle (*Lonicera* spp.), yellow flag iris (*Iris pseudacorus*), and Japanese knotweed (*Reynoutria japonica*). However, native species with high pollinator and wildlife values such as goldenrods (*Solidago* spp.), poison ivy (*Toxicodendron radicans*), jewelweed (*Impatiens capensis*), stinging nettle (*Urtica dioica*), American pokeberry (*Phytolacca americana*), sedges (*Carex* spp.), sensitive fern (*Onoclea sensibilis*), button bush (*Cephalanthus occidentalis*), speckled alder (*Alnus incana*), common yarrow (*Achillea millefolium*), and staghorn sumac (*Rhus typhina*) have persisted through the disturbances.

Other than athletic fields, playgrounds, trails, and parking areas, the project area between the vegetated riparian buffer and the closest DCR Parkway mainly consists of open lawn, lawn with tree canopy, and pockets of woodlands with mature trees. A strip of trees and shrubs is present between the Parkway and the park land. Vegetation along this strip is considered part of the Parkway's historic character and maintain in accordance with DCR's Parkway Master Plan (Toole Design, 2021).

2.1 Routine Vegetation Management Landscape Types

DCR maintains hundreds of thousands of acres of recreational space across the Commonwealth of Massachusetts. It is necessary to maintain these recreational spaces to ensure safe and enjoyable access to these valuable public spaces. The DCR property around the Charles River is no exception.

As part of their park lands, DCR conducts various types of regular maintenance along the Charles River Reservation. Vegetation maintenance is conducted to maintain recreational use, accessibility of pathways and public space, health of specific ecosystems, scenic vistas, landscaping, etc. Routine maintenance within the project area is classified into eight Landscape Types (Table 1; Figure C5). Each Landscape Type falls under one of two Landscape Designations: Naturalized Area (NA) or Reservation Facility (RF).

Table 1. Routine Maintenance Landscape Types within the Project Area

Landscape Type	Key	Area Description	Designation	Size within the Project Area
Lawn	L	Mown turf, natural surface athletic fields, day-use areas	RF	86.16 ac
Meadow	M	Meadows including upland and wetland	NA	2.11 ac
River's Edge	RE	Managed rivers edge (special events and other)	NA	29,686.56 ft
Woodland	T	Mature canopy trees, woodland ground plane with possible shrub understory	NA	19.75 ac
Green Infrastructure	GI	Maintained vegetated stormwater basins and swales, stormwater wetlands, and nature-based solutions	RF	4.42 ac
Landscaped Areas	LA	Vistas, maintenance areas, community gardens, cultural landscape types, etc.	RF	8.19 ac
Circulation	C	Pathways, roads, bridges	RF	9.50 ac; 79,622 ft
Structures	S	Buildings, gates, fences, shoreline infrastructure, utility infrastructure, etc.	RF	2.51 ac; 6,123.97 ft

Note: NA = Naturalized Area; RF = Reservation Facility; ac = acre; ft = linear feet.

2.1.1 Tree Management

As noted in Table 1, there are woodland areas with mature trees within the project area. There are also trees within Bank or in close proximity to Bank and other landscaped areas throughout the project area. DCR continues to prioritize tree inventory, assessment, and as-needed maintenance of these trees. The Lower Basin of the Charles River Reservation is an extremely high use park, where park visitors interact with natural resources, including trees, with a frequency and to an extent perhaps unmatched anywhere else in the DCR system. As landowner and manager, DCR has an explicit responsibility to care for and manage the trees in the park with three priorities serving as guiding principles: 1) maintenance of safety for visitors and DCR staff, 2) maintenance of the ecological health of the park system and 3) maintenance of the aesthetic values of the park that are the foundation of visitor experience.

An updated tree inventory will be conducted, and the resulting plan based on the results of this inventory will be submitted to the Boston Conservation Commission as an addendum to this filing. [The Esplanade Association and Harvard Boathouse staff have already updated their tree inventory, the results of which have been submitted to the Conservation Commission.](#) DCR is currently contracting Bartlett Tree to finish the remainder of the tree survey within the 2022 calendar year. The results will be submitted to the Conservation Commission. The full details of this update are included in Appendix E. Tree maintenance and continued monitoring is a large-scale effort for the proposed project and will be reported on annually as updated data and/or tree maintenance are needed.

DCR requests that the updated tree survey and ongoing specific maintenance details be presented to the Boston Conservation Commission in annual reporting and not be required in their entirety under this filing due to the very large scale of the project. No tree removal or maintenance will take place until the arboreal study is completed. The only exception to this is if there are trees threatening public health and safety. DCR will notify the Boston Conservation Commission if trees become hazardous to public health and safety.

2.2 Special Event Area Descriptions

There are two special events within the project area that require vegetation management in Boston. These events include the Head of the Charles Regatta (HOC) and the Fourth of July celebration. These events require viewing corridor vegetation pruning in specific sections of Bank and riparian zone within the project area. Vegetation management is also completed to provide views of the water for emergency personnel.

Details on the Head of the Charles and Fourth of July Celebration are included below.

2.2.1 Head of the Charles Regatta

The HOC is the largest rowing competition in the world. The event has been held on the Charles River since 1965. The 3-mile racecourse begins at Boston University's DeWolfe Boathouse in Cambridge and ends at Artesani Park in Allston Brighton. The race brings more than 300,000 spectators to the banks of the river. The HOC vegetation management area extends from just upstream of the Artesani Playground Spray Deck to the Western Avenue Bridge. Vegetation management, including event-specific tree maintenance and removal, occurs during the months of August, September, and October. The total linear extent of vegetation trimming associated with the HOC is 6,231 linear feet (1.18 miles). The bank cutting associated with temporary docks is included in this impact calculation.

2.2.2 Fourth of July Celebration

Fourth of July celebrations have been held at the Hatch Shell since 1973, when David Mugar conceived of energizing the Boston Pops Esplanade concert with Tchaikovsky's 1812 Overture, cannons, and fireworks. Boston 4 Celebrations, a non-profit organization, is responsible for coordinating all phases of the celebration. Each year approximately 500,000 people view the fireworks display from both sides of the Lower Basin, boats in the water, and the Harvard and Longfellow Bridges. Approximately 100,000 to 150,000 people view the celebration in the Esplanade, with about 9,000 to 10,000 visitors inside the Music Oval.

The Fourth of July vegetation management area extends from the Boston University Bridge to the Route 28 Bridge (at the Museum of Science) and includes the Esplanade lagoons. Vegetation management, including tree maintenance and removal, occurs between the months of May and June. The total linear extent of vegetation trimming for the Fourth of July is 19,820 linear feet (3.7 miles).

2.3 Invasive Plant Focus Areas

Although there are many invasive plants present within the full project area, DCR has identified four specific focus areas for invasive plant management. These have been prioritized based on their proximity to high-traffic areas, feasibility of management within the next three to five years, and presence of high-concern plant species. These four focus areas are described in Table 2. These areas extend throughout IVW, BVW, Bank, BLSF, RFA, and the 100-foot buffer to Bank and BVW. Focus areas also extend into areas jurisdictional under the Ordinance, including IVW, Waterfront Area, and the 100-foot buffer zone to IVW.

Table 2. Invasive Plant Focus Areas (west to east-northeast)

Focus Area Location	Area Description	Invasive Plant Species (square feet)
1. Daly Field and Tennis Courts	Extends across a 460-foot section of riparian zone (20 to 40 feet wide) in between Bank and the existing bike path, which is to the north of the Daly Field and Tennis Courts. (Total Focus Area: 0.17 acres)	Japanese knotweed (619.85) Shrub honeysuckle (8.63) Glossy buckthorn (574.90) Asiatic bittersweet (217.18) Swallowwort spp. (0.21) Norway maple (105.77) Japanese barberry (0.21)
2. Dr. Paul Dudley White Bike Path (Arsenal Street Bridge)	Extends approximately 995 feet west of the Arsenal Street Bridge between the Dr. Paul Dudley White Bike Path and Bank. (Total Focus Area: 0.84 acres)	Japanese knotweed (6050.06) Black locust (4098.28) European buckthorn (1640.41) Glossy buckthorn (91.86) Asiatic bittersweet (1.75) Norway maple (566.89) Tree of heaven (474.56)
3. Herter Park South	Approximately 6.82 acres of land between the Dr. Paul Dudley White Bike Path parking area across from Charles River Community Health, the Northeastern University Boathouse, Soldiers Field Road, and Bank. (Total Focus Area: 7.51 acres)	Phragmites (37371.20) Japanese knotweed (19857.69) Shrub honeysuckle (13.76) European buckthorn (42545.28) Multiflora Rose (4.45) Asiatic Bittersweet (110.26) Purple loosestrife (4962.62) Tree of heaven (3161.18) Swallowwort (777.58)
4. Herter Park North	Extends from the Northeastern University Boathouse to Eliot Bridge (approximately 4,485 feet (0.85 miles) long), withing approximately 20 feet of Bank. (Total Focus Area: 2.59 acres)	Japanese knotweed (842.66) Barberry, Japanese/European (1.14) Hedge bindweed (351.28) Asiatic bittersweet (168.96) Purple loosestrife (0.57) Reed canarygrass (0.21) Multiflora rose (5.51)

Note: Square footage of invasive plants is determined by absolute percent cover within species-specific field delineated polygons. Invasive plant coverage is overlapping and do not represent cumulative impacts to resource areas. See Table 7 for the total impact to resource areas.

3 REGULATED WETLAND RESOURCE AREAS

A desktop analysis of environmental constraints was performed using Massachusetts Geographic Information System (MassGIS) data layers, U.S. Geological Survey (USGS) StreamStats, and other publicly available data. SWCA also reviewed recent resource area delineations, including unpublished data related to the Herter Park Master Plan (Halverson, 2022). In addition, SWCA conducted a site delineation between January 12 and January 26, 2022, to confirm the presence of previously delineated resource areas throughout the project area.

The proposed CRVMP project area contains BVW, Bank, RFA, BLSF, and buffer zone, as these resource areas are defined by 310 CMR 10.00. There are also management areas within IVW and Waterfront Area, as defined and regulated in the Ordinance. Representative photographs of the project area depicting existing conditions are included in Appendix D.

The following sections define the on-site regulated resource areas. Table 3 includes a breakdown of which resource areas would be impacted by each type of proposed vegetation management.

Table 3. Types of Vegetation Management within Jurisdictional Resource Areas

Resource Area	<u>Routine Maintenance</u>								<u>Specific Vegetation Management</u>				
	L	M	RE	T	GI	LA	C	S	IS Focus Areas				Special Events
									1	2	3	4	
BVW				X*		X*	X*				XX	XX	
IVW†				X*		X*	X*				X		
Bank		XX	X	XX	X*	XX	XX	XX	XX	XX	XX	XX	XX
RFA		X		X	X	X	X	X	X	X	X	X	X
BLSF		X	X	X		X	X	X	X	X	X	X	X
Waterfront Area†		X		X	X	X	X	X	X	X	X		

Note: Impact is overlapping in some resource areas and these values are not cumulative; IS = Invasive Plant Species; † = Ordinance-regulated only; X = impact present within resource area; X* = impact present within buffer zone only; XX = impact within resource area and buffer zone.

3.1 Inland Bank (310 CMR 10.54)

As defined in 310 CMR 10.54 (2)(a and c), a Bank is "the portion of the land surface which normally abuts and confines a water body. It occurs between a water body and a vegetated bordering wetland and adjacent flood plain, or, in the absence of these, it occurs between a water body and an upland. A Bank may be partially or totally vegetated, or it may be comprised of exposed soil, gravel or stone.... The upper boundary of a Bank is the first observable break in the slope or the mean annual flood level, whichever is lower. The lower boundary of a Bank is the mean annual low flow level."

The majority of the project area extends along the Bank and its buffer zone. Portions of the proposed vegetation management activities will occur within the Bank of the Charles River. The Charles River has been actively managed since the 1700s and water levels have been under anthropogenic control since 1910. Along the project area, the Bank consists of a combination of natural (soil) and engineered (stone armored) embankment that is partially vegetated with native, nonnative, and invasive species. The majority of the Bank in the project area is steep (>15% slope) and provides an abrupt change from river to upland area. The steepest sloped area is on either side of Arsenal Street. From the water’s edge to the top of the Bank, the slope of the Bank itself is relatively steep (>15%) with a wooded/high shrub riparian edge and abrupt transition from water’s edge to a relatively flat, gently sloping upland area. Some of the shorelines with low herbaceous/passive recreation areas have gradual (<5%) slopes (Weston and Sampson 2019).

Existing engineered structures include revetments and riprap. The predominant plant community in these areas are false indigo (along the shore edge), evening primrose (*Oenothera biennis*), New England aster (*Symphyotrichum novae-angliae*), and goldenrod. Common invasive plants present are phragmites, Japanese knotweed, and others. There are also various sections of Bank with bulkheads, which are an engineered structure to protect vulnerable shorelines and working waterfront. They do not commonly house vegetation.

Natural Banks throughout the project area predominantly contain shrubs and herbaceous plants with some sections of intermittent to dense tree canopy. The predominant tree community in these areas of Bank include red maple (*Acer rubrum*), oaks (*Quercus* spp.), beech (*Fagus* spp.), ash (*Fraxinus* spp.), and white pine (*Pinus strobus*) as well as invasive trees such as tree of heaven and Norway maple (*Acer*

platanoides). The understory in these areas commonly include poison ivy and various invasive plant species (buckthorn, barberry, multiflora rose, Asiatic bittersweet, etc.).

Portions of the Bank have eroded because of wake action from water-based recreation, stormwater overflow across the Reservation, and human disturbance associated with land-based recreation. Several wildlife species have been observed utilizing the Bank for basking (e.g., turtles and snakes) and shelter (e.g. aquatic animals, rabbits [*Sylvilagus floridanus*], squirrels [*Sciurus* spp.] and chipmunks [*Tamias striatus*]). The vegetation present along the Bank also provides forage for insects, birds, fish, other aquatic animals and small mammals as well as nesting sites for birds, rabbits and other small mammals. Bank vegetation helps provide shade, cooling the river's shoreline, and helps to prevent Bank erosion and improve stormwater water permeability.

3.2 Bordering Vegetated Wetland (310 CMR 10.55)

As defined in 310 CMR 10.55(a–c), BVW are “area(s) where the soils are saturated and/or inundated such that they support a predominance of wetland indicator plants, 50% or more of the vegetative community consists of wetland indicator species, and the ground surface water regime and the vegetative community which occurs in each type of freshwater wetland area specified in [the WPA]” The boundaries of the on-site wetlands were determined in accordance with the U.S. Army Corps of Engineers (USACE) Wetland Delineation (Environmental Laboratory 1987), the Regional Supplement to the Corps of Engineers Wetland Delineation Manual: Northcentral and Northeast Region (Version 2.0) (USACE 2011), as well as in accordance with the WPA and 310 CMR 10.55(2)(c) and further described in MassDEP’s Delineating Bordering Vegetated Wetlands Under the Massachusetts Wetlands Protection Act (1995).

SWCA identified one BVW (Wetland W1) approximately 880 feet (0.17 miles) east of North Beacon Street Bridge along the southern bank of the Charles River. The BVW is classified as a palustrine broad-leaf deciduous scrub-shrub wetland (PSS) located at the toe of slope. The wetland borders a storm drain channel, specifically where the storm drain connects to the Charles River. A culvert, located north of the bike path, feeds the channel. The adjacent upland consists primarily of broad-leaved deciduous forest. Wetland W1 is flagged with pink and black flagging tape inscribed with “Wetland Delineation.” W1 is flagged W1-100 to W1-105 on the western side of the channel and W1-200 to W1-203 on the eastern side of the channel. The wetland is dominated primarily by red maple and glossy buckthorn (*Frangula alnus*). The top layer of soil consists of saturated sandy loam transitioning entirely to muck. Primary and secondary indicators of hydrology were observed, including high water table, soil saturation, water-stained leaves, and geomorphic position. Data forms for these delineations can be found in Appendix A.

The majority of the wetland is within 25 feet of the Charles River Bank and along the Fourth of July trimming route. However, due to the density and size of trees in the surrounding wooded area and the distance of the BVW from the bike path, it does not appear that this location has been managed for Fourth of July trimming in the recent past and will most likely not be subject to vegetation management.

A second BVW, delineated by Halvorson in 2021, surrounds the Herter Park Amphitheater and connects to the southern bank of the Charles River. This BVW is a man-made moat that ranges approximately 20 to 70 feet in width. Standing water is present within the BVW, along with herbaceous vegetation.

The third BVW is located approximately 100 feet west of the SWCA W3 (see Section 3.5 for description). This wetland was delineated by Halvorson in 2021. The wetland consists mostly of phragmites in the herbaceous layer. The wetland is 7,244 square feet.

3.3 Bordering Land Subject to Flooding (310 CMR 10.57)

As defined in 310 CMR 10.57(2)(a), BLSF is “an area with low, flat topography adjacent to and inundated by flood waters rising from creeks, rivers, streams, ponds or lakes. It extends from the banks of these waterways and water bodies; where a bordering vegetated wetland occurs, it extends from said wetland... The boundary of Bordering Land Subject to Flooding is the estimated maximum lateral extent of flood water which will theoretically result from the statistical 100-year frequency storm. Said boundary shall be that determined by reference to the most recently available flood profile data prepared for the community within which the work is proposed under the National Flood Insurance Program (NFIP, currently administered by the Federal Emergency Management Agency, successor to the U.S. Department of Housing and Urban Development). Said boundary, so determined, shall be presumed accurate.”

BLSF within the project area are located between Herter Park and south of the Eliot Bridge. The work to be performed within this area includes invasive plant management within the focus areas as well as Special Event trimming. Although these areas are identified as 100-year floodplain, it is unlikely that the area will flood at the projected 100-year frequency due to the active management of the dam.

3.4 Riverfront Area (310 CMR 10.58)

As defined in 310 CMR 10.58 (2)(a), a RFA is “the area of land between a river's mean annual high water line and a parallel line measured horizontally. The [RFA] may include or overlap other resource areas or their buffer zones.” Mean annual high water line (MAHWL) is defined under 10.58 (2)(a)(2) as the line apparent “from visible markings or changes in the character of soils or vegetation due to the prolonged presence of water... Field indicators include changes in slope, changes in vegetation...”, etc. SWCA identified the MAHWL as concurrent with the first break in slope as the delineation of Bank, which was used to measure the extent of RFA within the project bounds. 10.58 (2)(a)3.a. indicates that the horizontal setback for RFA in Boston is 25 feet from the MAHWL (or Bank, as defined above).

The RFA along the project area consists mostly of a naturally vegetated 3- to 5-foot strip adjacent to the mean low water line that transitions into an actively used park area with grass, trails, typical park infrastructure, and scattered trees. In addition, the Charles River Reservation (including the project area) was developed in 1910. As such, for purposes of the WPA and the River's Protection Act, all of the RFA is considered altered and disturbed.

3.5 Isolated Vegetated Wetland (Ordinance)

The Ordinance protects IVWs, which are defined as freshwater wetlands “which do not border on any permanent water body.” In order to qualify for jurisdiction, an IVW must cover “at least 1,000 square feet in area... and must also meet the definitions of BVW (310 CMR 10.55(2)) with the exception that these wetlands do not border any creeks, rivers, streams, ponds, lakes or other water bodies.”

SWCA identified and flagged two IVWs (W2 and W3) located near the Charles River Community Garden and southwest of the Northeastern University Boathouse. The first IVW, W2, is located south of the community garden, with a small wood chipped path separating it from the garden boundary. The wetland is approximately 2,530 square feet and consists primarily of purple loosestrife (*Lythrum salicaria*) and common soft rush (*Juncus effusus*). The soils consisted of saturated sandy loam with a water table at 9 inches. Primary and secondary indicators of hydrology were observed, including surface water, high water table, soil saturation, and geomorphic position.

The second IVW, W3, is approximately 9,320 square feet and located along a hillside southwest of the community garden. The wetland consists primarily of phragmites and purple loosestrife. The soils in the area consisted of silty loam with a fluctuating water table between 6 to 2 inches within the dense phragmites patch. The hillside is approximately 5% slope with the wetland separated by a maintained grass patch from the paved walking path. Evidence of groundwater seepage was observed in the form of active water seepage across the paved path and saturated soils at the time of the site visit. Primary and secondary indicators of hydrology were observed, including high water table, soil saturation, and microtopographic relief.

Both W2 and W3 are dominated by invasive plant species, purple loosestrife and phragmites, and are located within a previously disturbed area. The surrounding upland area consists of maintained grass landscaping, glossy buckthorn, gray birch (*Betula populifolia*), and Japanese knotweed in the shrub layer, and green ash (*Fraxinus pennsylvanica*) in the overstory. Data forms for these wetlands can be found in Appendix A.

3.6 Waterfront Area (Ordinance)

The Ordinance additionally protects an area within the buffer zone called Waterfront Area, which is defined as “the portion of the buffer zone which extends 25 feet horizontally from the edge of ... inland bank ... [and] riverfront area” as it pertains to the proposed project. The Waterfront Area within the project area includes an additional 25-foot setback from the RFA line and the first 25-foot buffer from Bank, a total of 50 feet of protection from mean annual high water. Therefore, the Ordinance protects the entire 50-foot buffer from Bank as Waterfront Area.

3.7 Buffer Zone

As defined in 310 CMR, Bank and BVW afforded a 100-foot buffer zone. The Ordinance provides additional protections for buffer zones as jurisdictional resource areas. The Ordinance defines buffer zone as “100 feet horizontally lateral from the boundary of any Resource Area, including: freshwater or coastal wetland... bank, reservoir, stream...” The regulated buffer zone in the project area therefore includes all areas within 100 feet of BVW, IVW, and Bank.

The 100-foot buffer zone to the BVW W1 consists of a broad-leaf deciduous forest with signs of previous disturbance, such as pieces of concrete and asphalt mixed in with the soil. Trees in this area do not appear to be recently managed.

BVW located around Herter Park consists of managed landscape and a community garden. The buffer zone is actively used by people throughout the day and in all seasons. The BVW surrounds a hill on which there is an amphitheater. The buffer zone surrounding the three IVWs is partially wooded, partially consists of shrubs, and partially maintained walking path and landscaping.

4 OTHER ENVIRONMENTAL CONSTRAINTS

SWCA reviewed the MassGIS to determine if this site was within or near other sensitive environmental areas that protect rare species, important watersheds, or other special environmental characteristics. No other sensitive resources, including Natural Heritage & Endangered Species Program (NHESP) Priority and Estimated Habitat, Certified Vernal Pools, Areas of Critical Environmental Concern, or Outstanding Resource Waters were identified within the project area (MassGIS 2021a, 2021b, 2021c, 2013, 2009, and

2010). There are also no AUL sites nor DEP Tier Classified 21E Sites (21E sites) located within the proposed work area (MassGIS 2021d and 2021e).

5 PROPOSED WORK

The proposed scope of work associated with this NOI submission includes all planned vegetation management under the updated CRVMP within the City of Boston. That management is divided into three categories: 1) routine maintenance, 2) specific vegetation management, and 3) restoration. Each of these vegetation management types have specific associated areas of focus, timing, and scope. The proposed work has been designed to minimize impact as much as practicable and does not include any soil disturbance, fill, or other alteration other than management of vegetation. Furthermore, the invasive plant species management will target specific plant species and all previous special events trimming will be conducted in the previously approved manner.

5.1 Routine Maintenance

Table 4 includes a list of each Landscape Type as described in Section 2.3 and a description of the prescribed management activities for that Landscape Type.

Table 4. Summary of Prescribed Management Activities by Routine Maintenance Landscape Type

Landscape Type	Key	Area Description	Management Description
Lawn	L	Mown turf, natural surface athletic fields, day-use areas (Total of 86.74 acres in Boston)	<u>Active Management:</u> Bimonthly mowing to 4 inches during growing season. Restored as needed with compost/clean soil and seeding* <u>Avoidance/Minimization:</u> only mown when ground is firm and dry; avoided near trees, shrubs, and plantings <u>Purpose:</u> provide safe recreational resources to the public
Meadow	M	Meadows including upland and wetland (Total of 2.11 acres in Boston)	<u>Minimal management:</u> once a year (spring or fall) – cut vegetation left on site <u>Purpose:</u> maintain wildflower or grassland to low maintenance habitat
River's Edge	RE	Managed rivers edge (special events and other) (Total of 29,687 feet in Boston)	<u>Minimal management:</u> once a year (trim tree branches) <u>Purpose:</u> Provide access to views of the river – predominantly prior to special events and across from installed benches
Woodland	T	Mature canopy trees, woodland ground plane with possible shrub understory? (Total of 19.83 acres in Boston)	<u>Periodic maintenance:</u> tree pruning* and removal are performed following arborist review of trees*. Other vegetation management is conducted with mowers, weedwhackers, and chainsaws. <u>Purpose:</u> ensure safe access to all portions of the project area and enhance aesthetics and health of vegetation in question
Green Infrastructure	GI	Maintained vegetated stormwater basins and swales, stormwater wetlands and nature-based solutions. (Total of 4.42 acres in Boston)	<u>Minimal management:</u> in accordance with the infrastructure Operations and Maintenance Plan

Landscape Type	Key	Area Description	Management Description
Landscaped Areas	LA	Vistas, maintenance areas, community gardens, cultural landscape types, etc. (Total of 8.19 acres in Boston)	<u>Regular management</u> : maintenance includes raking, weeding, clearing fallen branches, removal of dead plant material, and shrub pruning. Areas are replanted and reseeded as necessary* <u>Purpose</u> : maintain aesthetics and safety within planned landscaped areas
Circulation	C	Pathways, roads, bridges, (Total of 9.5 acres and 79,622 feet in Boston)	<u>Active management</u> : bimonthly during growing season to maintain a +/- 5-foot lawn buffer on each side of circulation areas. A +/- 10-foot buffer is managed adjacent to bridges and ramps for woody vegetation. Includes trimming vegetation that encroach on public parkways, sidewalks, paths, bridges, and trails. <u>Purpose</u> : provide safe access and promote favorable conditions for public use.
Structures	S	Buildings, gates, fences, shoreline infrastructure, utility infrastructure, etc. (Total of 2.51 acres and 6,124 feet in Boston)	<u>Minimal management</u> : only performed as needed to remove unwanted vegetation from structures. <u>Purpose</u> : safety for pedestrians and structure maintenance access, and aesthetics

Notes: * DCR has developed approved seed and planting lists as well as tree assessment and management details (Appendix E).

In addition to the work described in these Landscape Types, DCR is committed to the continued survey and maintenance of trees within the project area (See section 5.1.10 below) and working with partners to manually remove invasive plants at Herter Park (See section 5.1.11 below).

Table 5 includes the total impact of each Landscape Type by resource area and buffer.

Table 5. Total Resource Area Impacts within Vegetation Management Types

Resource Area	<u>Routine Maintenance</u>							
	L	M	RE	T	GI	LA	C	S
BVW (sf)	-	-	-	-	-	-	-	-
<i>100-ft Buffer (sf)</i>	-	-	-	1,719	-	3,700	11,120	-
IVW† (sf)	-	-	-	-	-	-	-	-
<i>100-ft Buffer† (sf)</i>	-	-	-	666	-	1,925	2,195	-
Bank (LF)	-	-	29,687	2	-	-	-	9,186
<i>100-ft Buffer (sf)</i>	-	3,560	-	5,447	1,424	1,138	188,750	2,454
RFA (sf)	-	-	-	2,584	-	722	87,423	9,211
BLSF (sf)	-	-	58,140	594	-	36	246,646	10,983
Waterfront Area† (sf)	-	2,964	-	1,249	71	3,050	28,097	35,813

Note: IS = Invasive Plant Species; † = Ordinance-regulated only; As standard lawn maintenance is not subject to the Act, the area of lawn maintenance has been removed from this filing. Only the following percentages of each Landscape Type include actual impact (subject to the Act and ordinance) to wetland resources and buffer zones: 1% of the T, 15% of GI, 10% of LA; 50% of S.

5.2 Specific Vegetation Management

In addition to general operations and maintenance, DCR also conducts specific vegetation management for special events and special improvement projects. There are three special recreational events that require vegetation management within DCR property in the project area. These special events include the

Fourth of July celebration and the HOC, which all take place within the Boston section of the Charles River.

The HOC is a large event that hundreds of spectators and competitors come to view from the banks of the Charles River each year. Similarly, residents visit the Charles River each Fourth of July to view the fireworks from its banks. As these are short-term events, they only require vegetation management **once annually**, leading up to their scheduled date. **In the past, vegetation management was completed along the riparian buffer by cutting all vegetation to the bank’s surface. In addition, trees were assessed by the DCR Arborist and maintained or removed based on a visual assessment. However, vegetation management practices have become less impactful by focusing on the trimming of nuisance and invasive vegetation to a height of 24 inches (from the nearest at grade surface). Temporary dock areas continue to be cut flush to the ground in order to provide safe access to the docks. There are a total of six temporary docks installed as part of the HOC. Tree pruning and removal continues to occur prior to events based on the DCR Arborist’s assessment. Vegetation management, temporary dock installation, and tree management is limited to the areas identified on Figure 6 in Appendix C.**

The **proposed** vegetation management **activities** in this CRVMP NOI include Bank vegetation *trimming* at specific sections of Bank (e.g., viewsheds, view corridors, temporary dock deployment sites) throughout Boston. These areas are located on Figure C6 and detailed in Table 6. All target vegetation (**nuisance and invasive vegetation; mostly false indigo bush**) is trimmed to a height of 24 inches with the exception of six temporary dock locations. **Native vegetation is avoided during these trimming events and any signs of wildlife use (i.e. bird nests) is noted and the surrounding vegetation is avoided (trimming is not conducted).** The vegetation landward of these temporary docks is cut to the ground elevation to allow safe access. **These areas are identified on Figure C6 as a yellow point, while all other target vegetation to be trimmed to 24-inches for the HOC is restricted to thick purple line symbolized on Figure C6.**

The special improvement project included in this NOI entails targeted invasive plant management. DCR strives to manage non-native invasive plant species throughout their properties. However, invasive plants are widespread and can be difficult to manage without a specific plan of action. DCR has identified four focus areas within Boston in which invasive plant management will be prioritized over the next 3 to 5 years. These focus areas were surveyed by SWCA between January 12 and January 26, 2022. The full extent of invasive plants and each plant’s total footprint within each focus area can be seen in Figure C6. Table 5 includes the details of all specific vegetation management associated with this proposed project.

The proposed special event trimming activities are a onetime trim of nuisance shrubs, specifically wild indigo, and invasive species, and therefore a temporal loss. Both the wild indigo and invasive species will continue to grow and sprout following this one-time trim. Trimming will not increase solar exposure or change the overall habitat type, nor will it impact the chemistry or biology of the habitat. Trimming with a combination of mechanical tools such as rotary cut mower (or similar), loppers, chainsaws, pole saws, etc. will also avoid impacts to the soil and the Bank’s existing topography.

Table 6. Specific Vegetation Management Details*

Special Event/Project	Location	Vegetation	Management Description
Head of the Charles Regatta	Artesani Playground Spray Deck to the Western Avenue Bridge	Nuisance and non-native invasive vegetation	Trim all target vegetation to a minimum height of 24 inches in all areas except for temporary docks, which are cut to the ground surface. Maintain clusters of native plants for pollinator and other wildlife habitat and avoid trimming around any nests.

Special Event/Project	Location	Vegetation	Management Description
Fourth of July Celebration	Daly Field to the Western Avenue Bridge	Nuisance and non-native invasive vegetation	Trim all vegetation to a minimum height of 24 inches in all areas except for temporary docks, which are cut to the ground surface. Maintain clusters of native plants for pollinator and other wildlife habitat and avoid trimming around any nests.
Invasive Plant Management	(1) Daly Field and Tennis Courts	Japanese knotweed Shrub honeysuckle Glossy buckthorn Asiatic bittersweet Swallowwort spp. Norway maple Japanese barberry	The predominant vegetation in this area is woody vines and shrubs. These invasive plants will be hand-removed where possible and where not possible, they will be managed through cut-stem herbicide application and other methods detailed in Appendix F. Japanese knotweed will be managed through selective foliar herbicide application. Norway maples will be inspected to determine the priority of management and potentially girdled. Swallowwort will be hand-dug where possible or sprayed with triclopyr where not. Mowing will not be a feasible means of swallowwort management in this area.
Invasive Plant Management	(2) Dr. Paul Dudley White Bike Path (Arsenal Street Bridge)	Japanese knotweed Black locust European buckthorn Glossy buckthorn Asiatic bittersweet Norway maple Tree of heaven	The priority species for management in this area is Japanese knotweed. Approximately 75% of the Japanese knotweed in this location will be managed through herbicide application, as it is widespread and overhanging the bank, where seed can be easily disseminated downstream. The remaining 25% of Japanese knotweed in this area will be managed with the mesh Japanese knotweed method. Black locust, Norway maple, and tree of heaven will be girdled or treated via cut-stem herbicide application. Buckthorn will be hand-removed or treated with cut-stem herbicide application.
Invasive Plant Management	(3) Herter Park South	Phragmites Japanese knotweed Shrub honeysuckle European buckthorn Multiflora Rose Asiatic Bittersweet Purple loosestrife Tree of heaven Swallowwort	The primary invasive plant of concern in this area is phragmites, which will either need to be excavated and monitored for resprouting (following up with selective foliar herbicide application) or be cut to the surface and treated with herbicide. Japanese knotweed in this area will be managed with the mesh Japanese knotweed method, as the populations are isolated and small. Purple loosestrife will be hand-pulled prior to seed development (spring) and treated with herbicide in areas of dense infestations. Swallowwort will be hand-dug where possible or sprayed with triclopyr where not. Mowing is not a feasible means of swallowwort management in this area. All other woody invasive plants will be hand-pulled where small enough and treated via cut-stem herbicide application where not.
Invasive Plant Management	(4) Herter Park North	Japanese knotweed Barberry Hedge bindweed Asiatic bittersweet Purple loosestrife Reed canarygrass Multiflora rose	Japanese knotweed in this area will be managed via selective herbicide application. The patch should be cut in the late spring where possible to reduce the full-height growth of the plant. Reed canarygrass will also require herbicide application in this area. Asiatic bittersweet and multiflora rose will be hand-pulled in locations where stems are small enough and be treated via foliar or cut-stem herbicide application where this is not possible. Purple loosestrife will be hand-pulled where sparse and treated via foliar herbicide application where dense.

Management Notes: * See Appendix F for more details on invasive plant management strategies. This table is intended as a brief overview of likely management methods. Foliar herbicide application should be conducted with a systemic herbicide (e.g., glyphosate, triclopyr), which should be carefully sprayed onto the foliage of the plant during its time of flowering or as close to it as possible without impacting pollinators. Cut-stem herbicide application involves cutting the target vegetation at or very close to the ground surface and applying a concentrated solution of herbicide to the freshly cut stem. Girdling involves cutting the bark and cambium in a circle around the trunk and should be conducted in the spring. Mesh Japanese knotweed treatment involves cutting the existing knotweed to the ground, clearing all vegetation from the area, covering the ground in mesh at the surface. This results in self-pruning as the Japanese knotweed grows wider than the diameter of the mesh, and eventually killing the stand over time.

Table 7 includes the total impact of each specific vegetation management type by each wetland resource and its buffer.

Table 7. Impact Calculations within Specific Vegetation Management Areas

Resource Area	Invasive Plant Focus Areas				Special Events	
	1	2	3	4	HOC	FOJ
BVW (sf)	-	-	6,158	-		
<i>100-ft Buffer (sf)</i>	-	-	18,909	44		
IVW[†] (sf)	-	-	7,819	-		
<i>100-ft Buffer (sf)</i>	-	-	11,604	-		
Bank (LF)	-	70	-	118	6,231	19,820
<i>100-ft Buffer (sf)</i>	717	15,817	24,207	607	6,231	19,820
RFA (sf)	657	12,707	4,111	607	6,231	19,820
BLSF (sf)	340	1,154	104	517		
Waterfront Area[†] (sf)	71	2,651	6,625	-		

Note: IS = Invasive Plant Species; † = Ordinance-regulated only; HOC = Head of the Charles; FOJ = Fourth of July; Invasive plant management impacts have been refined based on the percent cover of invasive plants in each resource area.

5.3 Restoration Goals

While DCR has not yet developed a full restoration plan for this proposed vegetation management program, Table 8 details ongoing restoration goals across various sections of the Charles River Reservation. The Landscape Areas in which DCR will focus restoration projects predominantly include Lawn and River’s Edge. These areas will be restored to allow for more passive maintenance. Any areas of lawn that are underutilized in the Reservation will be converted to native meadow and River’s Edge areas will be systematically restored with native plantings and seed that are low-growing and resilient to the activities associated with the three special events within the project area. DCR will submit an annual plan to the Conservation Commission prior to the start of each field season. This plan will include restoration planting and seeding as well as invasive plant management activities planned for the coming field season.

DCR has developed a seed and planting pallet to be used consistently throughout the Reservation. The seed mix was developed to emphasize the use of native as well as cultural/historic plantings in the park. It is DCR’s intent to encourage the use of the seed/planting pallet for all DCR and partner projects. The planting pallet and planting specifications are attached in Appendix E.

Bank cutting (for visual access of the river) is an interim activity. As part of the project area restoration, DCR shall prioritize bank restoration to reduce the extent of cutting incrementally every year. Special events areas will be prioritized first, and Test Plots will be restored 2 years following their installation (2023). Potential restoration includes invasive and nuisance species removal, replacement with low-growing native vegetation, and bioengineered improvements.

Table 8. Restoration Goals

Proposed Site	Restoration Goal
General Site Restoration (Post Event and Routine Maintenance)	<p>Monitor and vegetate exposed soils and other areas of concern using plant/seed material from the Charles River Seed mix and knowledge gained from the test plots. Stabilize using straw mulch and/or all-natural fiber erosion control blanket as necessary. Restoration areas larger than 10 square feet may require the installation of temporary bird deterrent fencing and the fencing installed around the Test Plots. See Appendix E for the approved Test Plot restoration designs that will be implemented within the project area throughout the course of the permit.</p> <p>If rutting and soil compaction results from vegetation management activities, the area shall be returned to pre-existing conditions, and comparable to the surrounding area, by light hand raking or back blading with machinery (bank excluded). Deep ruts (>10-inches) shall be filled using available loose soil from the general area.</p> <p>Implement CRVMP framework to guide future restoration projects. Seeding and planting details are included in Appendix E.</p>
HOC Temporary Dock Locations	<p>Increase the sustainability and decrease the erodibility of the bank segments frequently managed for temporary docks associated with special events. DCR will work with partners to develop several designs that will promote resource protection while allowing the use and access of the bank for special event. Ideas include revegetation of the bank with low growing hardy vegetation and bio engineering. DCR will present details to the Commission once available. No improvements will be made without the Commission's review and approval.</p>
Invasive Plant Focus Areas	<p>Monitor and revegetate with seed as needed; practice adaptive management and use various methods of management and active restoration when needed.</p>

Note: Test plots were previously permitted through the Boston Conservation Commission and DEP (DEP File No. 006-1780) DCR implemented various bank restoration methods to determine which are the most successful to inform future bank stabilization projects.

5.3.1 Ecological Restoration Limited Project Context

This NOI is being filed as an Ecological Restoration Limited Project because of the overall restoration goals of the project. General historic maintenance (Landscape Type and special events maintenance) is planned to be reduced in multiple manners: (1) restoration of riparian areas following results of test plots (2) conversion of underutilized lawn to native meadow, and (3) overall resilient stewardship goals included in Section 1.

These restoration activities further the following interests of the act. Additionally, each interest listed includes additional information regarding the precise relevant restoration activities.

- Storm damage prevention
 - Restoring bare or lightly vegetated sections of Bank and riparian zone
 - Restoring temporary dock location (special events) vegetation to low-growing, resilient, and hardy vegetation
- Prevention of pollution
 - Increasing the stability and buffering capacity of bank and riparian zone through native restoration
- Protection of wildlife habitat
 - Invasive plant management and restoration with native plant species
 - Restoration general maintenance and special event trimming vegetation to reduce future need for trimming and maintenance (i.e. restore with resilient vegetation that does not require trimming, continued maintenance)
 - Converting underutilized lawn areas to open meadow habitat

5.4 Proposed Impact Calculations

The three types of proposed vegetation management are proposed throughout the project footprint but occur at different times of year and at different intervals. Therefore, there is overlap in the total impact of each type of vegetation. The total impact for the entire project is presented in Table 9 by each regulated wetland resource area. These total impact calculations were determined in ArcGIS based on the overlap of each delineated resource area and the total proposed footprint of all aspects of the CRVMP.

Table 9. Resource Area Impact Calculations

Resource Area	Total Impact	Impact to Buffer Zone
BVW	6,158 square feet	35,564 square feet
IVW	7,819 square feet	16,390 square feet
Bank	38,875 linear feet	202,772 square feet
RFA	118,022 square feet	N/A
BLSF	318,514 square feet	N/A
Waterfront Area	80,590 square feet	N/A

Note: Some resource area calculations overlap and are not cumulative. However, it was not possible to determine which portions of invasive plant management and general maintenance completely overlap. Therefore, there is a slight overestimation of impacts between various aspects of vegetation management for this project.

BVW = Bordering Vegetated Wetland; IVW = Isolated Vegetated Wetland; RFA = Riverfront Area; BLSF = Bordering Land Subject to Flooding; IFRZ = Inland Flood Resilience Zone.

6 GENERAL PROVISIONS AND PERFORMANCE STANDARDS REVIEW

Proposed projects that are subject to the WPA and its implementing regulations must demonstrate how they comply with the general provisions and applicable performance standards. While the Ordinance went into effect in December 2019, regulations implementing the Ordinance have not been issued; however, they are currently being promulgated. Table 10 and the following sections detail the general provisions and performance standards under the WPA associated with the regulated wetland resource area in which the proposed work would occur.

Table 10. General Provisions of all Wetlands and Inland Wetlands (310 CMR 10.03 and 10.53)

Citation	Regulation	Compliance
310 CMR 10.03(1)(a)1. 310 CMR 10.53(1)	The area is not significant to the protection of any of the interests identified in the WPA.	There are no permanent impacts proposed as part of the proposed work. Temporary impacts associated with vegetation management will be targeted and means to minimize regular special event trimming are being assessed currently to decrease the frequency of vegetation trimming needs.
310 CMR 10.03(1)(a)2. 310 CMR 10.53(1)	Work within a resource area will contribute to the protection of the interests of the WPA.	The proposed work that is the subject of this NOI will be located within an area subject to regulation but will not adversely affect any resource areas.
310 CMR 10.03(1)(a)3. 310 CMR 10.53(1)	Work within the buffer zone will contribute to the protection of the interests of the WPA.	Work within the buffer zone is necessary to maintain existing recreational properties and the needs of those properties (active and passive recreation). No work will result in any adverse

Citation	Regulation	Compliance
		impacts to regulated wetland resource areas and will not diminish the ability of the project area to contribute to the interests of the WPA.
310 CMR 10.03(1)(b) 310 CMR 10.53(1)	Claims of work outside of any jurisdictional area impacting a jurisdictional area must demonstrate the work has had an adverse impact.	Not applicable.
310 CMR 10.53(2)	Proposed project subject to a Restriction Order shall conform to both provisions contained in that Order and 310 CMR 10.51 through 10.60	There are no Restriction Orders associated with the proposed work area.
310 CMR 10.03(2)	Credible evidence from a competent source to support the position taken when contesting DEP's position.	Not applicable.
310 CMR 10.03(3)	Installation of subsurface sewage disposal systems.	Not applicable.
310 CMR 10.03(4)	Presumption concerning point-source discharges.	Not applicable.
310 CMR 10.03(5)	Each resource area is presumed to be significant to the interests of the WPA.	All impacts are temporary and furthermore are either part of an active ecological restoration initiative or planned to be restored in coming years in order to minimize trimming activities. Furthermore, all properties proposed for vegetation management are already actively managed by DCR to maintain recreational use.
310 CMR 10.03(6)	Presumption concerning the application of herbicides.	Herbicide application will be minimized to the extent possible and will be limited to the management of invasive and nuisance vegetation within the project area. The selective use of herbicides will be lawfully conducted and will further the protection of wildlife habitat (interest of the WPA) through the elimination of invasive plants and restoration of native vegetation.
310 CMR 10.53(7)	Project involving construction, repair, replacement, or expansion of public or private infrastructure.	While this project does not include the construction, repair, replacement, or expansion of public infrastructure, DCR has submitted this CRVMP as an operations and maintenance plan, because it is critical to the operations of DCR parkland.
310 CMR 10.03(7)(a)	Filing fees for NOIs pursuant to the WPA.	Copies of checks are included in Appendix A.
310 CMR 10.53(8)	Regarding replacement of an existing stream crossing.	Not applicable.

6.1 Bank (310 CMR 10.54(4))

Impacts to Bank are temporary and *de minimis* in nature and consist of trimming nuisance shrubs and invasive species from their existing height to a minimum of 24 inches. Vegetated areas will remain vegetated thus not limiting the Bank's ability to protect the interests specified in 310 CMR 10.54(1), including wildlife habitat. Provisions under 310 CMR 10.54[4]b–c are not included here, as they are not applicable. There are no structures proposed within the project area and there are no features of concern under Massachusetts Endangered Species Act mapped by NHESP within the project area.

(a) Where the presumption set forth in 310 CMR 10.54(3) is not overcome, any proposed work on a Bank shall not impair the following:

1. the physical stability of the Bank, 2.the water carrying capacity of the existing channel within the Bank, 3. ground water and surface water quality 4. the capacity of the Bank to provide breeding habitat, escape cover and food for fisheries, 5. the capacity of the Bank to provide important wildlife habitat functions. A project... that (cumulatively) alter(s) up to 10% or 50 feet (whichever is less) of the length of the Bank found to be significant to the protection of wildlife habitat, shall not be deemed to impair its capacity to provide important wildlife habitat functions.

Trimming of nuisance and invasive vegetation should have no effect on the Bank's physical stability, carrying capacity, or capacity to provide breeding habitat. The proposed activities are a onetime trim of nuisance shrubs, specifically wild indigo, and invasive species, and therefore a temporal loss. Both the wild indigo and invasive species will continue to grow and sprout following this one-time trim. Trimming will not increase solar exposure or change the overall habitat type, nor will it impact the chemistry or biology of the habitat. Trimming with a flail mower (or similar) will also avoid impacts to the soil and the Bank's existing topography. Moreover, trimming will be conducted in a manner sensitive to wildlife. DCR will avoid cutting any shrubs with nests and will avoid all nests noted during cutting. As a result, the project activities will not have long term or adverse effect and will not reduce the Bank's capacity to provide important wildlife habitat functions. As an Ecological Restoration Limited Project, the project is not subject to the requirement to complete a wildlife habitat evaluation under 310 CMR 10.60.

Trimming of nuisance and invasive vegetation should have no effect on the groundwater and surface water quality. Remaining native and trimmed vegetation will continue to assist with water filtration. All trimmed vegetation will be removed from the project area including the river (to the maximum extent possible). Fueled equipment will remain outside of the Bank and spill kits will be available in case of a spill emergency. Staff accompanying the mower operator will assist with plant material removal from the river and alert the operator if any spills are observed.

6. Work on a stream crossing shall be presumed to meet the performance standard set forth in 310 CMR 10.54(4) (a)(b)(c)

The proposed work does not include any stream crossings.

6.2 Bordering Vegetated Wetland (310 CMR 10.55(4))

Work within BVW will be minimal. The only BVW within the project area includes a very small wetland (W1 approximately 880 feet [0.17 miles] east of North Beacon Street Bridge), which will not be impacted by any proposed vegetation management and the moat at Herter Park, which will only be impacted during Fourth of July vegetation trimming.

(a) Where the presumption set forth in 310 CMR 10.55(3) is not overcome, any proposed work in a Bordering Vegetated Wetland shall not destroy or otherwise impair any portion of said area.

The proposed work within BVW is very minimal and only includes once-per-year vegetation trimming for the Fourth of July celebration. None of this trimming will impair any portion of BVW.

(b) & (c) Notwithstanding the provisions of 310 CMR 10.55(4)(a), the issuing authority may issue an Order of Conditions permitting work which results in the loss of ... Bordering Vegetated Wetland ...

There will be no loss of BVW as a result of the proposed work.

(d) Notwithstanding the provisions of 310 CMR 10.55(4)(a), (b) and (c), no project may be permitted which will have any adverse effect on specified habitat sites of rare vertebrate or invertebrate species, as identified by procedures established under 310 CMR 10.59.

Not applicable. The project does not occur within any mapped habitat for rare species as identified by the most recent mapping provided by NHESP (NHESP 2021a, b)

(e) Any proposed work shall not destroy or otherwise impair any portion of a Bordering Vegetated Wetland that is within an Area of Critical Environmental Concern designated by the Secretary of Energy and Environmental Affairs under M.G.L. c. 21A, § 2(7) and 301 CMR 12.00: Areas of Critical Environmental Concern.

Not applicable. The project does not occur within any Areas of Critical Environmental Concern.

6.3 Bordering Land Subject to Flooding (310 CMR 10.57(4)(a))

Impacts to the BLSF are temporary in nature and consist of trimming nuisance shrubs and invasive species from their existing height to a minimum of 24 inches, as well as active invasive plant management within two of the four identified focus areas. Vegetated areas will remain vegetated and there will be no change in topography, flood storage or ground infiltration. Project activities are not anticipated to limit the floodplain's ability to protect the interests specified in 310 CMR 10.57(2)(a)(3).

- 1. Compensatory storage shall be provided for all flood storage volume that will be lost as the result of a proposed project within Bordering Land Subject to Flooding, when in the judgment of the issuing authority said loss will cause an increase or will contribute incrementally to an increase in the horizontal extent and level of flood waters during peak flows.*

This is not applicable as there is no proposed fill associated with this project.

- 8. Work within Bordering Land Subject to Flooding, including that work required to provide the above-specified compensatory storage, shall not restrict flows so as to cause an increase in flood stage or velocity.*

This is not applicable, as there is no proposed fill associated with this project.

- 9. Work in those portions of bordering land subject to flooding found to be significant to the protection of wildlife habitat shall not impair its capacity to provide important wildlife habitat functions.*

As explained above, the proposed project activities should not result in an alteration to any habitat characteristics. Where they do, there will be an improvement to habitat through the elimination of invasive vegetation and restoration of native plant communities. In addition, impacts from the project activities are temporary in nature. Trimming of vegetation will not kill any vegetation and will be conducted with care; leaving vegetation that is of value to pollinators during the time of trimming. DCR anticipates that the vegetation will continue to grow after the trimming as well as into the next growing season. As an Ecological Restoration Limited Project, the project is not subject to the requirement to complete a wildlife habitat evaluation under 310 CMR 10.60.

6.4 Riverfront Area (310 CMR 10.58(4))

Impacts to the RFA are temporary in nature and consist of trimming nuisance shrubs and invasive species from their existing height to a minimum of 24 inches as well as active invasive plant management within the four identified Focus Areas. Vegetated areas will remain vegetated. Therefore, the proposed work will not limit the RFA's ability to protect the interests specified in 310 CMR 10.58(4).

(a) Protection of Other Resource Areas. The work shall meet the performance standards for all other resource areas within the riverfront area, as identified in 310 CMR 10.30 (Coastal Bank), 10.32 (Salt Marsh), 10.55 (Bordering Vegetated Wetland), and 10.57 (Land Subject to Flooding).

A small portion of the project is located within BLSF and BVW. However, the project will not result in any impacts to topography or change in flood storage. The performance standard for this regulated wetland resource area has been taken into consideration and is addressed in Sections 6.4 and 6.2, respectively.

(b) Protection of Rare Species. No project may be permitted within the riverfront area which will have any adverse effect on specified habitat sites of rare wetland or upland, vertebrate or invertebrate species, as identified by the procedures established under 310 CMR 10.59 or 10.37, or which will have any adverse effect on vernal pool habitat certified prior to the filing of the Notice of Intent.

Not applicable. The project does not occur within any mapped habitat for rare species as identified by the most recent mapping provided by NHESP (NHESP 2021)

(c) Practicable and Substantially Equivalent Economic Alternatives. There must be no practicable and substantially equivalent economic alternative to the proposed project with less adverse effects on the interests identified in M.G.L. c. 131 § 40.

There is no practicable or equivalent alternative that would achieve the goals of the proposed project. Furthermore, a portion of the project includes restoration through invasive and nuisance vegetation management to establish a flourishing native vegetative community. As such, this project will result in an improvement to overall quality of habitat within RFA. DCR submitted a brief alternatives analysis with an Administrative Review in 2021, which is included in Appendix A of this NOI submittal.

6.5 Isolated Vegetated Wetlands (Boston Wetland Regulations, Section XIV.D.)

The following Performance Standards have been defined in the Boston Wetlands Regulations for IVW.

1. *... Any proposed work or activity... shall not destroy or otherwise impair any portion of [IVW].*

The only proposed impact to IVW is the management of invasive phragmites, which will be restored with native vegetation. No IVW will be destroyed, rather IVW will be enhanced through the proposed project.

2. *...The Commission may issue an Order of Conditions permitting work or activity which results in the loss of up to 50% of IVW, but not to exceed 5,000 square feet...*

There will be no loss of IVW. The invasive plant management there within will enhance IVW.

3. *...The Commission shall consider the magnitude of the alteration and significance of the affected area...[and the means of] the project to contribute to the protection of the Resource Area Values identified in Section XIV(A).*

The proposed project will protect and/or enhance the following Resource Area Values:

- Protection of public and private water supply and ground water supply and protection of pollution
 - Restored vegetation will help to filter contaminants prior to them matriculating into the water supply
- Protection of flood control and storm damage prevention
 - Restored vegetation will include a mixture of woody and herbaceous vegetation, which will effectively uptake water, help decrease the velocity of stormwater, and decrease the potential impacts of flooding within and surrounding the identified IVW on site.
- The protection of fisheries and to wildlife habitat
 - The invasive plants (particularly phragmites) currently dominating the IVW do not currently provide effective habitat for native wildlife. Eliminating invasive vegetation and restoring the IVW with suitable native vegetation will provide superior habitat for native wildlife species.

4. *In regard to replication and restoration; and 5. In regard to replication and restoration in the loss of a portion of IVW*

This is not applicable. There will be no loss of IVW.

6. *In regard to the removal of trees*

No trees are planned to be removed from the IVW identified on site. Should any hazardous trees need to be removed from this area in the future, DCR will communicate with the Conservation Commission at that time.

7. *In regard to resource area values*

See Section XIV.D.3, above.

8. *... No project may be permitted that will have any adverse impact on specified habitat sites of rare vertebrate or invertebrate species indicated on the most recent Estimated Habitat Map of State-listed Rare Wetlands Wildlife...*

There are no areas of Estimated Habitat of State-listed Rare species within the project area.

9. *Any proposed work or activity shall not destroy or otherwise impair any portion of an IVW that is within ACEC...*

Not applicable.

10. *In regard to Section XIV(D)(9) and 310 CMR 10.53(3)(a), (d), (j), (k), (l), or (q) or 310 CMR 10.24(7)(b).*

Not applicable.

11. *If the IVW affected by proposed work or activity is significant to the Resource Area Values described in Section XIV(A), the applicant shall take into consideration the impacts of climate change.*

Not applicable. See response to Section XIV.D.3 above. Furthermore, the restoration of invasive plant species will be performed with resilient native vegetation in an effort to increase resilience to climate change.

12. *An applicant's failure to take into account Impacts of Climate Change and incorporate mitigation, resilience, and/or adaptation to the Impacts of Climate change shall be an*

independent basis for the Commission to determine that a NOI is incomplete or will otherwise adversely impact the Resource Area Values protected by the Ordinance and these regulations.

See Section 1 of this NOI narrative to details on the intent to increase resilience to Impacts of Climate Change through this proposed project. As stated in response to Section XIV.D.11, restoration of the IVW on site will be performed by eradicating invasive vegetation and restoring the area will flood-resilient native vegetation, which will increase the area's overall ability to withstand the impacts of climate change and will reduce the impacts of periodic flooding that may be observed as an impact to climate change.

7 AVOIDANCE, MINIMIZATION, AND RESTORATION

DCR will minimize all impacts the extent practicable and will **restore** any impacts through systematic restoration practices. DCR has specific minimization strategies for all general activities, Charles River's edge trimming best management practices (BMPs), and invasive plant management minimization practices and BMPs to avoid and reduce impact. Additional restoration information is included in Appendix E.

7.1 General Minimization Strategies

The following minimization strategies are applicable to all activities associated with the proposed work presented in this NOI.

- Vegetation management activities shall adhere to the following stipulations
 - Inspect all equipment prior to arrival onsite
 - Ensure all are properly functioning, all hoses are in good condition (no leaks)
 - Conducted during dry conditions only to as to avoid rutting
 - Does not apply to hand pruning and cutting activities
- Equipment storage, use, and maintenance shall adhere to the following stipulations
 - Conduct all equipment travel along finished grade and on parkland, avoiding exposed tree roots
 - E.g., turf grass, trails, paths, and the Paul Dudley White Greenway
 - Store spill kit(s) near areas where fueled maintenance equipment is being used
 - Spill kit shall include absorbent pads and disposable bags.
 - DCR's Spill Prevention and Control Plan (Appendix G) will be implemented in the event of a spill.
 - Store fueled equipment outside of regulated wetland resource areas and buffers, or in existing paved parking areas when not in use
 - Conduct all equipment maintenance and fueling outside of regulated wetland resource areas and buffers or in paved parking areas
 - Clean equipment that has been placed or used within areas containing invasive species prior to leaving those invasive areas
 - Clean all plant matter (stems, flowers, roots, etc.), soil, or other deleterious materials

7.2 Special Events River's Edge Trimming

Special event trimming activities have been designed to avoid, minimize, and **restore** impacts to regulated wetland resource areas. By using a combination of rotary deck mower (or similar) traveling along the actively used areas of the Reservation and manual cutters (loppers, chainsaws, pole saws), cutting nuisance shrubs and invasive vegetation at 24 inches from the finished grade, and avoiding the trimming of native species.

DCR has proposed this method to meet the following avoidance and minimization outcomes.

- Eliminate the possibility of scalping the ground and Bank
- Retain the Bank's existing topography (no rutting)
- Retain the existing vegetative structure, native plants, and overall micro habitat of the riparian buffer
- Reduce the likelihood of erosion and additional stormwater inputs

These practices are in place for all DCR contractors and internal staff. In the event that the trimming is completed by a DCR designee, DCR shall conduct an onsite meeting with the contractor to review the project area, limits of trimming, and minimization and avoidance practices. DCR shall extend an invitation to the Conservation Commission for this meeting. Any wildlife nests or other important wildlife areas will be flagged for avoidance.

7.3 Invasive Plant Management

All of the above-detailed BMPs also apply to invasive plant management. In addition, DCR will ensure that the following overall BMPs are implemented.

Cutting and Removal of Invasive Vegetation

Invasive plant material cut as part of the invasive plant management shall be disposed consistent with the following by vegetation type.

- Woody material without flowers or seeds: create small stockpiles away from wetlands and recreational facilities (to be coordinated with operations)
- Non woody material: bag and dispose of appropriately
- Flower or seed heads: dead head, bag and dispose of appropriately

Herbicide Application

Only individuals appropriately licensed and certified by the Massachusetts Department of Agricultural Resources Pesticide Bureau will be allowed to apply herbicides. Herbicide applications must comply with all applicable local, state, and federal regulations. DCR must approve all herbicides and surfactants prior to their application.

Additionally, herbicides will not be applied during the following adverse weather conditions.

- High wind velocity, per 333 CMR 11.03(6)
- During periods of dense fog, or moderate to heavy rainfall

- During periods of high temperatures and low humidity (applications of volatile herbicides only)
- When rain is forecast within the 24-hour period after a scheduled application

When applying herbicides, the contractor will follow all labeled restrictions. All plant control treatments will follow all applicable federal and state laws and regulations. The contractor shall provide DCR with copies of any forms/reports filed regarding herbicide application covered under this effort.

The contractor shall comply with all federal, state, and local laws and regulations controlling pollution of the environment. The contractor shall take necessary precautions to prevent pollution of streams, wetlands, and ponds with fuels, oils, chemicals, or other harmful materials and to prevent pollution of the atmosphere from particulate and gaseous matter.

The storage or disposal of fuels, oils, chemicals, or other harmful materials on any project sites or neighboring property is strictly prohibited.

The contractor shall provide to DCR a written record (log) of all work done, including herbicide applications showing dates and times of application, names and license numbers of applicators, weather conditions, volumes, concentrations, types of herbicide solutions used, and locations treated.

Manual Management

If management activities are completed by volunteers, Volunteer Stewardship Agreements shall be in place for the proposed activities.

8 SUMMARY

SWCA is submitting this NOI as an Ecological Restoration Limited Project under 310 CMR 10.53(4) to implement an updated CRVMP within the Charles River Reservation. The proposed project seeks to control invasive plant species and create a standard practice for special event vegetation management within Bank, BVW, IVW, BLSF, and RFA, as well as buffer zones associated with these regulated wetland resource areas. The goal of the proposed project is to reduce and systematically eliminate invasive plant species from the site and improve restoration and sustainable management practices during special events and general maintenance. This will be conducted improvements/refinement to general maintenance practices (Section 5.1), through selective trimming (special events, Section 5.2), the application of herbicide and manual removal (invasive plant management, Section 5.2), and systematic restoration (reseeding and/or revegetation of affected Bank and BVW with native wetland species, Section 5.3). Once implemented, the proposed management plan will increase native biodiversity and increase the habitat for native wildlife species, such as nesting birds.

All work performed within sensitive resource areas discussed in this NOI submission will be performed with the utmost care and selectivity. Sedimentation controls will not be necessary, as soil disturbance will not occur. Pesticides proposed for use are certified for aquatic use and will be applied with caution to non-target species. We are seeking a 5-year Ecological Restoration Order of Conditions to implement the CRVMP that focuses on annual monitoring and adaptive management.

9 LITERATURE CITED

Environmental Laboratory. 1987. Corps of Engineers Wetlands Delineation Manual. Technical Report Y-87-1, U.S. Army Engineer Waterways Experiment Station, Vicksburg, MS.

- Halvorson. 2021. Herter Park Wetland Delineation Data. Herter Park Master Plan (unpublished data).
- Massachusetts Department of Environmental Protection (MassDEP). 1995. Delineating Bordering Vegetated Wetlands Under the Massachusetts Wetlands Protection Act, A Handbook. March 1995.
- Massachusetts Geographic Information System (MassGIS). 2021a. NHESP Priority Habitat of Rare Species. Available at: <https://www.mass.gov/info-details/massgis-data-nhesp-priority-habitats-of-rare-species>. Accessed March 8, 2022.
- MassGIS. 2021b. NHESP Estimated Habitat of Rare Wildlife. Available at: <https://www.mass.gov/info-details/massgis-data-nhesp-estimated-habitats-of-rare-wildlife>.
- MassGIS. 2021c. NHESP Certified Vernal Pools. Available at: <https://www.mass.gov/info-details/massgis-data-nhesp-certified-vernal-pools>. Accessed March 8, 2022.
- MassGIS. 2021d. MassDEP Oil and/or Hazardous Material Sites with Activity and Use Limitations (AUL). Available at: <https://www.mass.gov/info-details/massgis-data-massdep-oil-andor-hazardous-material-sites-with-activity-and-use-limitations-aul>. Accessed March 8, 2022.
- MassGIS. 2021e. MassDEP Tier Classified Oil and/or Hazardous Material Site (MGL c. 21E). Available at: <https://www.mass.gov/info-details/massgis-data-massdep-tier-classified-oil-andor-hazardous-material-sites-mgl-c-21e>. Accessed March 8, 2022.
- MassGIS 2013. NHESP Potential Vernal Pools. Available at: <https://www.mass.gov/info-details/massgis-data-nhesp-potential-vernal-pools>. Accessed March 8, 2022.
- MassGIS. 2010. Outstanding Resource Waters. Available at: <https://www.mass.gov/info-details/massgis-data-outstanding-resource-waters>. Accessed March 8, 2022.
- MassGIS. 2009. Areas of Critical Environmental Concern. Available at: <https://www.mass.gov/info-details/massgis-data-areas-of-critical-environmental-concern>. Accessed March 8, 2022.
- Natural Heritage and Endangered Species Program (NHESP). 2021. Regulated NHESP Areas of Concern. Accessed March 8, 2022.
- Toole Design. 2021. DCR Parkways Master Plan. Prepared for the Commonwealth of Massachusetts. <https://www.mass.gov/doc/dcr-parkways-master-plan-2020/download>
- U.S. Army Corps of Engineers. 2011. Regional Supplement to the Corps of Engineers Wetland Delineation Manual: Northcentral and Northeast Region (Version 2.0), ed. J. S. Wakeley, R. W. Lichvar, C. V. Noble, and J. F. Berkowitz. ERDC/EL TR-12. Vicksburg, MS: U.S. Army Engineer Research and Development Center.
- Weston and Sampson. 2019. Charles River Basin Riverbank Vegetation Management Plan. Massachusetts Department of Conservation and Recreation.

APPENDIX A

Supporting Materials

WETLAND DETERMINATION DATA FORM – Northcentral and Northeast Region

Project/Site: Charles River Vegetation Management Plan City/County: Boston Sampling Date: January 24, 2022
 Applicant/Owner: Department of Conservation and Recreation, Commonwealth of Massachusetts State: MA Sampling Point: W2- Wetland
 Investigator(s): P. Safran and F. Hoey Section, Township, Range: _____
 Landform (hillslope, terrace, etc.): Toeslope Local relief (concave, convex, none): Concave Slope (%): 0
 Subregion (LRR or MLRA): LRR-R Lat: 42.363579 Long: -71.142429 Datum: NAD 88
 Soil Map Unit Name: Urban land, wet substratum NWI classification: n/a

Are climatic / hydrologic conditions on the site typical for this time of year? Yes No _____ (If no, explain in Remarks.)
 Are Vegetation _____, Soil , or Hydrology _____ significantly disturbed? Are "Normal Circumstances" present? Yes No _____
 Are Vegetation _____, Soil _____, or Hydrology _____ naturally problematic? (If needed, explain any answers in Remarks.)

SUMMARY OF FINDINGS – Attach site map showing sampling point locations, transects, important features, etc.

Hydrophytic Vegetation Present? Yes <input checked="" type="checkbox"/> No _____ Hydric Soil Present? Yes <input checked="" type="checkbox"/> No _____ Wetland Hydrology Present? Yes <input checked="" type="checkbox"/> No _____	Is the Sampled Area within a Wetland? Yes <input checked="" type="checkbox"/> No _____ If yes, optional Wetland Site ID: <u>Wetland- W2</u>
Remarks: (Explain alternative procedures here or in a separate report.) W-2 (Wet) is an isolated vegetated wetland located adjacent to a community garden surrounded by walking paths and maintained landscaping. The area appears to have been highly disturbed in the past.	

HYDROLOGY

Wetland Hydrology Indicators: <u>Primary Indicators (minimum of one is required; check all that apply)</u> <input checked="" type="checkbox"/> Surface Water (A1) _____ Water-Stained Leaves (B9) <input checked="" type="checkbox"/> High Water Table (A2) _____ Aquatic Fauna (B13) <input checked="" type="checkbox"/> Saturation (A3) _____ Marl Deposits (B15) _____ Water Marks (B1) _____ Hydrogen Sulfide Odor (C1) _____ Sediment Deposits (B2) _____ Oxidized Rhizospheres on Living Roots (C3) _____ Drift Deposits (B3) _____ Presence of Reduced Iron (C4) _____ Algal Mat or Crust (B4) _____ Recent Iron Reduction in Tilled Soils (C6) _____ Iron Deposits (B5) _____ Thin Muck Surface (C7) _____ Inundation Visible on Aerial Imagery (B7) _____ Other (Explain in Remarks) _____ Sparsely Vegetated Concave Surface (B8)	<u>Secondary Indicators (minimum of two required)</u> _____ Surface Soil Cracks (B6) <input checked="" type="checkbox"/> Drainage Patterns (B10) _____ Moss Trim Lines (B16) _____ Dry-Season Water Table (C2) _____ Crayfish Burrows (C8) _____ Saturation Visible on Aerial Imagery (C9) _____ Stunted or Stressed Plants (D1) <input checked="" type="checkbox"/> Geomorphic Position (D2) _____ Shallow Aquitard (D3) _____ Microtopographic Relief (D4) _____ FAC-Neutral Test (D5)
Field Observations: Surface Water Present? Yes <input checked="" type="checkbox"/> No _____ Depth (inches): <u>3"</u> Water Table Present? Yes <input checked="" type="checkbox"/> No _____ Depth (inches): <u>9"</u> Saturation Present? Yes <input checked="" type="checkbox"/> No _____ Depth (inches): <u>0"</u> (includes capillary fringe)	Wetland Hydrology Present? Yes <input checked="" type="checkbox"/> No _____
Describe Recorded Data (stream gauge, monitoring well, aerial photos, previous inspections), if available: Remarks: Both primary and secondary indicators of hydrology were observed at the W2 (Wet) plot. Surface water was present within the wetland, the soil sample was not taken within surface water location, therefore water table is at 9" where soil sample was taken.	

VEGETATION – Use scientific names of plants.

Sampling Point: W2- Wetland

Tree Stratum (Plot size: <u>30'</u>)	Absolute % Cover	Dominant Species?	Indicator Status															
1. <u>Fraxinus pennsylvanica</u>	<u>5</u>	Yes	FACW	Dominance Test worksheet: Number of Dominant Species That Are OBL, FACW, or FAC: <u>4</u> (A) Total Number of Dominant Species Across All Strata: <u>4</u> (B) Percent of Dominant Species That Are OBL, FACW, or FAC: <u>100</u> (A/B)														
2. _____	_____	_____	_____															
3. _____	_____	_____	_____															
4. _____	_____	_____	_____															
5. _____	_____	_____	_____															
6. _____	_____	_____	_____															
7. _____	_____	_____	_____															
<u>5</u> = Total Cover																		
Sapling/Shrub Stratum (Plot size: <u>15'</u>)	Absolute % Cover	Dominant Species?	Indicator Status															
1. <u>Fraxinus pennsylvanica</u>	<u>10</u>	Yes	FACW	Prevalence Index worksheet: <table style="width:100%; border:none;"> <tr> <td style="width:50%; text-align:right;">Total % Cover of:</td> <td style="width:50%; text-align:left;">Multiply by:</td> </tr> <tr> <td>OBL species <u>80</u></td> <td>x 1 = <u>80</u></td> </tr> <tr> <td>FACW species <u>15</u></td> <td>x 2 = <u>30</u></td> </tr> <tr> <td>FAC species <u>0</u></td> <td>x 3 = <u>0</u></td> </tr> <tr> <td>FACU species <u>0</u></td> <td>x 4 = <u>0</u></td> </tr> <tr> <td>UPL species <u>0</u></td> <td>x 5 = <u>0</u></td> </tr> <tr> <td>Column Totals: <u>95</u> (A)</td> <td><u>110</u> (B)</td> </tr> </table> Prevalence Index = B/A = <u>1.16</u>	Total % Cover of:	Multiply by:	OBL species <u>80</u>	x 1 = <u>80</u>	FACW species <u>15</u>	x 2 = <u>30</u>	FAC species <u>0</u>	x 3 = <u>0</u>	FACU species <u>0</u>	x 4 = <u>0</u>	UPL species <u>0</u>	x 5 = <u>0</u>	Column Totals: <u>95</u> (A)	<u>110</u> (B)
Total % Cover of:	Multiply by:																	
OBL species <u>80</u>	x 1 = <u>80</u>																	
FACW species <u>15</u>	x 2 = <u>30</u>																	
FAC species <u>0</u>	x 3 = <u>0</u>																	
FACU species <u>0</u>	x 4 = <u>0</u>																	
UPL species <u>0</u>	x 5 = <u>0</u>																	
Column Totals: <u>95</u> (A)	<u>110</u> (B)																	
2. _____	_____	_____	_____															
3. _____	_____	_____	_____															
4. _____	_____	_____	_____															
5. _____	_____	_____	_____															
6. _____	_____	_____	_____															
7. _____	_____	_____	_____															
<u>10</u> = Total Cover																		
Herb Stratum (Plot size: <u>5'</u>)	Absolute % Cover	Dominant Species?	Indicator Status															
1. <u>Lythrum salicaria</u>	<u>60</u>	Yes	OBL	Hydrophytic Vegetation Indicators: <input type="checkbox"/> 1 - Rapid Test for Hydrophytic Vegetation <input checked="" type="checkbox"/> 2 - Dominance Test is >50% <input checked="" type="checkbox"/> 3 - Prevalence Index is ≤3.0 ¹ <input type="checkbox"/> 4 - Morphological Adaptations ¹ (Provide supporting data in Remarks or on a separate sheet) <input type="checkbox"/> Problematic Hydrophytic Vegetation ¹ (Explain)														
2. <u>Juncus effusus</u>	<u>20</u>	Yes	OBL															
3. _____	_____	_____	_____															
4. _____	_____	_____	_____															
5. _____	_____	_____	_____															
6. _____	_____	_____	_____															
7. _____	_____	_____	_____															
8. _____	_____	_____	_____															
9. _____	_____	_____	_____															
10. _____	_____	_____	_____															
11. _____	_____	_____	_____															
12. _____	_____	_____	_____															
<u>80</u> = Total Cover																		
Woody Vine Stratum (Plot size: <u>30'</u>)	Absolute % Cover	Dominant Species?	Indicator Status															
1. _____	_____	_____	_____	Definitions of Vegetation Strata: Tree – Woody plants 3 in. (7.6 cm) or more in diameter at breast height (DBH), regardless of height. Sapling/shrub – Woody plants less than 3 in. DBH and greater than or equal to 3.28 ft (1 m) tall. Herb – All herbaceous (non-woody) plants, regardless of size, and woody plants less than 3.28 ft tall. Woody vines – All woody vines greater than 3.28 ft in height.														
2. _____	_____	_____	_____															
3. _____	_____	_____	_____															
4. _____	_____	_____	_____															
<u>0</u> = Total Cover																		
Remarks: (Include photo numbers here or on a separate sheet.) Photos of the W2 are located in a separate document. Hydrophytic vegetation dominates the plot and the prevalence index is <3.0.				Hydrophytic Vegetation Present? Yes <input checked="" type="checkbox"/> No _____														

WETLAND DETERMINATION DATA FORM – Northcentral and Northeast Region

Project/Site: Charles River Vegetation Management Plan City/County: Boston Sampling Date: January 24, 2022
 Applicant/Owner: Department of Conservation and Recreation, Commonwealth of Massachusetts State: MA Sampling Point: W3- Sample 1 Wetland
 Investigator(s): P. Safran and F. Hoey Section, Township, Range: _____
 Landform (hillslope, terrace, etc.): Hillslope Local relief (concave, convex, none): Concave Slope (%): 3
 Subregion (LRR or MLRA): LRR-R Lat: 42.363716 Long: -71.14307 Datum: NAD 88
 Soil Map Unit Name: Urban land, wet substratum NWI classification: n/a

Are climatic / hydrologic conditions on the site typical for this time of year? Yes No _____ (If no, explain in Remarks.)
 Are Vegetation _____, Soil , or Hydrology _____ significantly disturbed? Are "Normal Circumstances" present? Yes No _____
 Are Vegetation _____, Soil _____, or Hydrology _____ naturally problematic? (If needed, explain any answers in Remarks.)

SUMMARY OF FINDINGS – Attach site map showing sampling point locations, transects, important features, etc.

Hydrophytic Vegetation Present? Yes <input checked="" type="checkbox"/> No _____ Hydric Soil Present? Yes _____ No <input checked="" type="checkbox"/> Wetland Hydrology Present? Yes <input checked="" type="checkbox"/> No _____	Is the Sampled Area within a Wetland? Yes <input checked="" type="checkbox"/> No _____ If yes, optional Wetland Site ID: <u>Wetland- W3 Sample 1</u>
Remarks: (Explain alternative procedures here or in a separate report.) W-3 Sample 1 (Wet) is an isolated vegetated wetland located on a gentle slope surrounded by walking paths and maintained landscaping. The area appears to have been highly disturbed in the past. Several test plots were taken at this wetland, this plot is located on the edge of the dense Pharrmites patch.	

HYDROLOGY

Wetland Hydrology Indicators: Primary Indicators (minimum of one is required; check all that apply) <input type="checkbox"/> Surface Water (A1) <input type="checkbox"/> Water-Stained Leaves (B9) <input checked="" type="checkbox"/> High Water Table (A2) <input type="checkbox"/> Aquatic Fauna (B13) <input checked="" type="checkbox"/> Saturation (A3) <input type="checkbox"/> Marl Deposits (B15) <input type="checkbox"/> Water Marks (B1) <input type="checkbox"/> Hydrogen Sulfide Odor (C1) <input type="checkbox"/> Sediment Deposits (B2) <input type="checkbox"/> Oxidized Rhizospheres on Living Roots (C3) <input type="checkbox"/> Drift Deposits (B3) <input type="checkbox"/> Presence of Reduced Iron (C4) <input type="checkbox"/> Algal Mat or Crust (B4) <input type="checkbox"/> Recent Iron Reduction in Tilled Soils (C6) <input type="checkbox"/> Iron Deposits (B5) <input type="checkbox"/> Thin Muck Surface (C7) <input type="checkbox"/> Inundation Visible on Aerial Imagery (B7) <input type="checkbox"/> Other (Explain in Remarks) <input type="checkbox"/> Sparsely Vegetated Concave Surface (B8)	Secondary Indicators (minimum of two required) <input type="checkbox"/> Surface Soil Cracks (B6) <input checked="" type="checkbox"/> Drainage Patterns (B10) <input type="checkbox"/> Moss Trim Lines (B16) <input type="checkbox"/> Dry-Season Water Table (C2) <input type="checkbox"/> Crayfish Burrows (C8) <input type="checkbox"/> Saturation Visible on Aerial Imagery (C9) <input type="checkbox"/> Stunted or Stressed Plants (D1) <input type="checkbox"/> Geomorphic Position (D2) <input type="checkbox"/> Shallow Aquitard (D3) <input checked="" type="checkbox"/> Microtopographic Relief (D4) <input type="checkbox"/> FAC-Neutral Test (D5)
Field Observations: Surface Water Present? Yes _____ No <input checked="" type="checkbox"/> Depth (inches): _____ Water Table Present? Yes <input checked="" type="checkbox"/> No _____ Depth (inches): <u>6"</u> Saturation Present? Yes <input checked="" type="checkbox"/> No _____ Depth (inches): <u>2"</u> (includes capillary fringe)	Wetland Hydrology Present? Yes <input checked="" type="checkbox"/> No _____
Describe Recorded Data (stream gauge, monitoring well, aerial photos, previous inspections), if available: Remarks: Both primary and secondary indicators of hydrology were observed at the W3 (Wet) plot.	

VEGETATION – Use scientific names of plants.

W3- Sample 1
Sampling Point: Wetland

	Absolute % Cover	Dominant Species?	Indicator Status																													
Tree Stratum (Plot size: <u>30'</u>)																																
1. <u>Betula populifolia</u>	<u>5</u>	Yes	FAC	Dominance Test worksheet: Number of Dominant Species That Are OBL, FACW, or FAC: <u>2</u> (A) Total Number of Dominant Species Across All Strata: <u>2</u> (B) Percent of Dominant Species That Are OBL, FACW, or FAC: <u>100</u> (A/B)																												
2. _____																																
3. _____																																
4. _____																																
5. _____																																
6. _____																																
7. _____																																
	<u>5</u>	= Total Cover		Prevalence Index worksheet: <table style="width:100%; border:none;"> <tr> <td style="width:50%;"></td> <td style="text-align:center;">Total % Cover of:</td> <td style="width:50%;"></td> <td style="text-align:center;">Multiply by:</td> </tr> <tr> <td>OBL species</td> <td style="text-align:center;"><u>5</u></td> <td>x 1 =</td> <td style="text-align:center;"><u>5</u></td> </tr> <tr> <td>FACW species</td> <td style="text-align:center;"><u>80</u></td> <td>x 2 =</td> <td style="text-align:center;"><u>80</u></td> </tr> <tr> <td>FAC species</td> <td style="text-align:center;"><u>5</u></td> <td>x 3 =</td> <td style="text-align:center;"><u>15</u></td> </tr> <tr> <td>FACU species</td> <td style="text-align:center;"><u>0</u></td> <td>x 4 =</td> <td style="text-align:center;"><u>0</u></td> </tr> <tr> <td>UPL species</td> <td style="text-align:center;"><u>0</u></td> <td>x 5 =</td> <td style="text-align:center;"><u>0</u></td> </tr> <tr> <td>Column Totals:</td> <td style="text-align:center;"><u>90</u></td> <td>(A)</td> <td style="text-align:center;"><u>180</u> (B)</td> </tr> </table> Prevalence Index = B/A = <u>2.00</u>		Total % Cover of:		Multiply by:	OBL species	<u>5</u>	x 1 =	<u>5</u>	FACW species	<u>80</u>	x 2 =	<u>80</u>	FAC species	<u>5</u>	x 3 =	<u>15</u>	FACU species	<u>0</u>	x 4 =	<u>0</u>	UPL species	<u>0</u>	x 5 =	<u>0</u>	Column Totals:	<u>90</u>	(A)	<u>180</u> (B)
	Total % Cover of:		Multiply by:																													
OBL species	<u>5</u>	x 1 =	<u>5</u>																													
FACW species	<u>80</u>	x 2 =	<u>80</u>																													
FAC species	<u>5</u>	x 3 =	<u>15</u>																													
FACU species	<u>0</u>	x 4 =	<u>0</u>																													
UPL species	<u>0</u>	x 5 =	<u>0</u>																													
Column Totals:	<u>90</u>	(A)	<u>180</u> (B)																													
Sapling/Shrub Stratum (Plot size: <u>15'</u>)																																
1. _____																																
2. _____																																
3. _____																																
4. _____																																
5. _____																																
6. _____																																
7. _____																																
	<u>0</u>	= Total Cover																														
Herb Stratum (Plot size: <u>5'</u>)																																
1. <u>Phragmites australis</u>	<u>80</u>	Yes	FACW	Hydrophytic Vegetation Indicators: <input type="checkbox"/> 1 - Rapid Test for Hydrophytic Vegetation <input checked="" type="checkbox"/> 2 - Dominance Test is >50% <input checked="" type="checkbox"/> 3 - Prevalence Index is ≤3.0 ¹ <input type="checkbox"/> 4 - Morphological Adaptations ¹ (Provide supporting data in Remarks or on a separate sheet) <input type="checkbox"/> Problematic Hydrophytic Vegetation ¹ (Explain)																												
2. <u>Juncus effusus</u>	<u>5</u>	No	OBL																													
3. _____																																
4. _____																																
5. _____																																
6. _____																																
7. _____																																
8. _____																																
9. _____																																
10. _____																																
11. _____																																
12. _____																																
	<u>85</u>	= Total Cover																														
Woody Vine Stratum (Plot size: <u>30'</u>)																																
1. _____																																
2. _____																																
3. _____																																
4. _____																																
	<u>0</u>	= Total Cover		Definitions of Vegetation Strata: Tree – Woody plants 3 in. (7.6 cm) or more in diameter at breast height (DBH), regardless of height. Sapling/shrub – Woody plants less than 3 in. DBH and greater than or equal to 3.28 ft (1 m) tall. Herb – All herbaceous (non-woody) plants, regardless of size, and woody plants less than 3.28 ft tall. Woody vines – All woody vines greater than 3.28 ft in height.																												
Hydrophytic Vegetation Present? Yes <input checked="" type="checkbox"/> No <input type="checkbox"/>																																
Remarks: (Include photo numbers here or on a separate sheet.) Photos of the W3 are located in a separate document. Hydrophytic vegetation dominates the plot and the prevalence index is <3.0. Unidentified grass species present at the site (15%).																																

WETLAND DETERMINATION DATA FORM – Northcentral and Northeast Region

Project/Site: Charles River Vegetation Management Plan City/County: Boston Sampling Date: January 24, 2022
 Applicant/Owner: Department of Conservation and Recreation, Commonwealth of Massachusetts State: MA Sampling Point: W3- Sample 2 Wetland
 Investigator(s): P. Safran and F. Hoey Section, Township, Range: _____
 Landform (hillslope, terrace, etc.): Hillslope Local relief (concave, convex, none): none Slope (%): 3
 Subregion (LRR or MLRA): LRR-R Lat: 42.363725 Long: -71.143128 Datum: NAD 88
 Soil Map Unit Name: Urban land, wet substratum NWI classification: n/a

Are climatic / hydrologic conditions on the site typical for this time of year? Yes No _____ (If no, explain in Remarks.)
 Are Vegetation _____, Soil , or Hydrology _____ significantly disturbed? Are "Normal Circumstances" present? Yes No _____
 Are Vegetation _____, Soil _____, or Hydrology _____ naturally problematic? (If needed, explain any answers in Remarks.)

SUMMARY OF FINDINGS – Attach site map showing sampling point locations, transects, important features, etc.

Hydrophytic Vegetation Present? Yes <input checked="" type="checkbox"/> No _____ Hydric Soil Present? Yes <input checked="" type="checkbox"/> No _____ Wetland Hydrology Present? Yes <input checked="" type="checkbox"/> No _____	Is the Sampled Area within a Wetland? Yes <input checked="" type="checkbox"/> No _____ If yes, optional Wetland Site ID: <u>Wetland- W3 Sample 2</u>
Remarks: (Explain alternative procedures here or in a separate report.) W-3 Sample 2 (Wet) is an isolated vegetated wetland located on a gentle slope surrounded by walking paths and maintained landscaping. The area appears to have been highly disturbed in the past. Several test plots were taken at this wetland, this plot is located within the dense Pharmites patch.	

HYDROLOGY

Wetland Hydrology Indicators: <u>Primary Indicators (minimum of one is required; check all that apply)</u> ___ Surface Water (A1) ___ Water-Stained Leaves (B9) <input checked="" type="checkbox"/> High Water Table (A2) ___ Aquatic Fauna (B13) <input checked="" type="checkbox"/> Saturation (A3) ___ Marl Deposits (B15) ___ Water Marks (B1) ___ Hydrogen Sulfide Odor (C1) ___ Sediment Deposits (B2) ___ Oxidized Rhizospheres on Living Roots (C3) ___ Drift Deposits (B3) ___ Presence of Reduced Iron (C4) ___ Algal Mat or Crust (B4) ___ Recent Iron Reduction in Tilled Soils (C6) ___ Iron Deposits (B5) ___ Thin Muck Surface (C7) ___ Inundation Visible on Aerial Imagery (B7) ___ Other (Explain in Remarks) ___ Sparsely Vegetated Concave Surface (B8)	<u>Secondary Indicators (minimum of two required)</u> ___ Surface Soil Cracks (B6) <input checked="" type="checkbox"/> Drainage Patterns (B10) ___ Moss Trim Lines (B16) ___ Dry-Season Water Table (C2) ___ Crayfish Burrows (C8) ___ Saturation Visible on Aerial Imagery (C9) ___ Stunted or Stressed Plants (D1) ___ Geomorphic Position (D2) ___ Shallow Aquitard (D3) <input checked="" type="checkbox"/> Microtopographic Relief (D4) ___ FAC-Neutral Test (D5)
Field Observations: Surface Water Present? Yes _____ No <input checked="" type="checkbox"/> Depth (inches): _____ Water Table Present? Yes <input checked="" type="checkbox"/> No _____ Depth (inches): <u>2"</u> Saturation Present? Yes <input checked="" type="checkbox"/> No _____ Depth (inches): <u>0"</u> (includes capillary fringe)	Wetland Hydrology Present? Yes <input checked="" type="checkbox"/> No _____
Describe Recorded Data (stream gauge, monitoring well, aerial photos, previous inspections), if available: _____ _____	
Remarks: Both primary and secondary indicators of hydrology were observed at the W3 Sample 2 (Wet) plot.	

SOIL

Profile Description: (Describe to the depth needed to document the indicator or confirm the absence of indicators.)

Depth (inches)	Matrix		Redox Features				Texture	Remarks
	Color (moist)	%	Color (moist)	%	Type ¹	Loc ²		
0-2"	10YR 2/2	100	-	-	-	-	Loamy Sand	
2-7"	10YR 2/2	95	7.5YR 3/4	5	C	M	Silt Loam	Saturated
7-18"	10YR 3/2	85	7.5YR 3/4	10	C	M	Silt Loam	Saturated
			10YR 6/2	5	D	M		

¹Type: C=Concentration, D=Depletion, RM=Reduced Matrix, MS=Masked Sand Grains. ²Location: PL=Pore Lining, M=Matrix.

Hydric Soil Indicators:

- Histosol (A1)
- Histic Epipedon (A2)
- Black Histic (A3)
- Hydrogen Sulfide (A4)
- Stratified Layers (A5)
- Depleted Below Dark Surface (A11)
- Thick Dark Surface (A12)
- Sandy Mucky Mineral (S1)
- Sandy Gleyed Matrix (S4)
- Sandy Redox (S5)
- Stripped Matrix (S6)
- Dark Surface (S7) (LRR R, MLRA 149B)
- Polyvalue Below Surface (S8) (LRR R, MLRA 149B)
- Thin Dark Surface (S9) (LRR R, MLRA 149B)
- Loamy Mucky Mineral (F1) (LRR K, L)
- Loamy Gleyed Matrix (F2)
- Depleted Matrix (F3)
- Redox Dark Surface (F6)
- Depleted Dark Surface (F7)
- Redox Depressions (F8)

Indicators for Problematic Hydric Soils³:

- 2 cm Muck (A10) (LRR K, L, MLRA 149B)
- Coast Prairie Redox (A16) (LRR K, L, R)
- 5 cm Mucky Peat or Peat (S3) (LRR K, L, R)
- Dark Surface (S7) (LRR K, L)
- Polyvalue Below Surface (S8) (LRR K, L)
- Thin Dark Surface (S9) (LRR K, L)
- Iron-Manganese Masses (F12) (LRR K, L, R)
- Piedmont Floodplain Soils (F19) (MLRA 149B)
- Mesic Spodic (TA6) (MLRA 144A, 145, 149B)
- Red Parent Material (F21)
- Very Shallow Dark Surface (TF12)
- Other (Explain in Remarks)

³Indicators of hydrophytic vegetation and wetland hydrology must be present, unless disturbed or problematic.

Restrictive Layer (if observed):

Type: None observed
 Depth (inches): _____

Hydric Soil Present? Yes No

Remarks:

Water table was at 2 inches. Restrictive layer was not observed. The soil in this area is historically disturbed.

WETLAND DETERMINATION DATA FORM – Northcentral and Northeast Region

Project/Site: Charles River Vegetation Management Plan City/County: Boston Sampling Date: January 24, 2022
 Applicant/Owner: Department of Conservation and Recreation, Commonwealth of Massachusetts State: MA Sampling Point: W3- Sample 3 Wetland
 Investigator(s): P. Safran and F. Hoey Section, Township, Range: _____
 Landform (hillslope, terrace, etc.): Footslope Local relief (concave, convex, none): none Slope (%): 3
 Subregion (LRR or MLRA): LRR-R Lat: 42.36354 Long: -71.143328 Datum: NAD 88
 Soil Map Unit Name: Urban land, wet substratum NWI classification: n/a

Are climatic / hydrologic conditions on the site typical for this time of year? Yes No _____ (If no, explain in Remarks.)
 Are Vegetation _____, Soil , or Hydrology _____ significantly disturbed? Are "Normal Circumstances" present? Yes No _____
 Are Vegetation _____, Soil _____, or Hydrology _____ naturally problematic? (If needed, explain any answers in Remarks.)

SUMMARY OF FINDINGS – Attach site map showing sampling point locations, transects, important features, etc.

Hydrophytic Vegetation Present? Yes <input checked="" type="checkbox"/> No _____ Hydric Soil Present? Yes <input checked="" type="checkbox"/> No _____ Wetland Hydrology Present? Yes <input checked="" type="checkbox"/> No _____	Is the Sampled Area within a Wetland? Yes <input checked="" type="checkbox"/> No _____ If yes, optional Wetland Site ID: <u>Wetland- W3 Sample 3</u>
Remarks: (Explain alternative procedures here or in a separate report.) W-3 Sample 3 (Wet) is an isolated vegetated wetland located on a gentle slope surrounded by walking paths and maintained landscaping. The area appears to have been highly disturbed in the past. Several test plots were taken at this wetland, this plot is located within the southern purple loosestrife patch.	

HYDROLOGY

Wetland Hydrology Indicators: <u>Primary Indicators (minimum of one is required; check all that apply)</u> ___ Surface Water (A1) ___ Water-Stained Leaves (B9) ___ High Water Table (A2) ___ Aquatic Fauna (B13) <input checked="" type="checkbox"/> Saturation (A3) ___ Marl Deposits (B15) ___ Water Marks (B1) ___ Hydrogen Sulfide Odor (C1) ___ Sediment Deposits (B2) ___ Oxidized Rhizospheres on Living Roots (C3) ___ Drift Deposits (B3) ___ Presence of Reduced Iron (C4) ___ Algal Mat or Crust (B4) ___ Recent Iron Reduction in Tilled Soils (C6) ___ Iron Deposits (B5) ___ Thin Muck Surface (C7) ___ Inundation Visible on Aerial Imagery (B7) ___ Other (Explain in Remarks) ___ Sparsely Vegetated Concave Surface (B8)	<u>Secondary Indicators (minimum of two required)</u> ___ Surface Soil Cracks (B6) ___ Drainage Patterns (B10) ___ Moss Trim Lines (B16) ___ Dry-Season Water Table (C2) ___ Crayfish Burrows (C8) ___ Saturation Visible on Aerial Imagery (C9) ___ Stunted or Stressed Plants (D1) ___ Geomorphic Position (D2) ___ Shallow Aquitard (D3) ___ Microtopographic Relief (D4) ___ FAC-Neutral Test (D5)
Field Observations: Surface Water Present? Yes _____ No <input checked="" type="checkbox"/> Depth (inches): _____ Water Table Present? Yes _____ No <input checked="" type="checkbox"/> Depth (inches): _____ Saturation Present? Yes <input checked="" type="checkbox"/> No _____ Depth (inches): <u>4"</u> (includes capillary fringe)	Wetland Hydrology Present? Yes <input checked="" type="checkbox"/> No _____
Describe Recorded Data (stream gauge, monitoring well, aerial photos, previous inspections), if available: _____ _____	
Remarks: Saturation was observed at W3-Sample 3 plot. Water seepage was observed from the wetland onto the paved walking path, just west of the plot.	

VEGETATION – Use scientific names of plants.

W3- Sample 3
Sampling Point: Wetland

Tree Stratum (Plot size: <u>30'</u>)	Absolute % Cover	Dominant Species?	Indicator Status	Dominance Test worksheet:	
1. _____	_____	_____	_____	Number of Dominant Species That Are OBL, FACW, or FAC:	<u>1</u> (A)
2. _____	_____	_____	_____	Total Number of Dominant Species Across All Strata:	<u>3</u> (B)
3. _____	_____	_____	_____	Percent of Dominant Species That Are OBL, FACW, or FAC:	<u>33.3</u> (A/B)
4. _____	_____	_____	_____	Prevalence Index worksheet:	
5. _____	_____	_____	_____	Total % Cover of:	Multiply by:
6. _____	_____	_____	_____	OBL species <u>45</u>	x 1 = <u>45</u>
7. _____	_____	_____	_____	FACW species <u>0</u>	x 2 = <u>0</u>
	<u>0</u>	= Total Cover		FAC species <u>0</u>	x 3 = <u>0</u>
Sapling/Shrub Stratum (Plot size: <u>15'</u>)				FACU species <u>7</u>	x 4 = <u>28</u>
1. <u>Rosa multiflora</u>	<u>5</u>	Yes	FACU	UPL species <u>0</u>	x 5 = <u>0</u>
2. <u>Rubus allegheniensis</u>	<u>2</u>	Yes	FACU	Column Totals: <u>52</u> (A)	<u>73</u> (B)
3. _____	_____	_____	_____	Prevalence Index = B/A = <u>1.40</u>	
4. _____	_____	_____	_____	Hydrophytic Vegetation Indicators:	
5. _____	_____	_____	_____	<input type="checkbox"/> 1 - Rapid Test for Hydrophytic Vegetation	
6. _____	_____	_____	_____	<input checked="" type="checkbox"/> 2 - Dominance Test is >50%	
7. _____	_____	_____	_____	<input checked="" type="checkbox"/> 3 - Prevalence Index is ≤3.0 ¹	
	<u>7</u>	= Total Cover		<input type="checkbox"/> 4 - Morphological Adaptations ¹ (Provide supporting data in Remarks or on a separate sheet)	
Herb Stratum (Plot size: <u>5'</u>)				<input type="checkbox"/> Problematic Hydrophytic Vegetation ¹ (Explain)	
1. <u>Lythrum salicaria</u>	<u>45</u>	Yes	OBL	¹ Indicators of hydric soil and wetland hydrology must be present, unless disturbed or problematic.	
2. _____	_____	_____	_____	Definitions of Vegetation Strata:	
3. _____	_____	_____	_____	Tree – Woody plants 3 in. (7.6 cm) or more in diameter at breast height (DBH), regardless of height.	
4. _____	_____	_____	_____	Sapling/shrub – Woody plants less than 3 in. DBH and greater than or equal to 3.28 ft (1 m) tall.	
5. _____	_____	_____	_____	Herb – All herbaceous (non-woody) plants, regardless of size, and woody plants less than 3.28 ft tall.	
6. _____	_____	_____	_____	Woody vines – All woody vines greater than 3.28 ft in height.	
7. _____	_____	_____	_____		
8. _____	_____	_____	_____		
9. _____	_____	_____	_____		
10. _____	_____	_____	_____		
11. _____	_____	_____	_____		
12. _____	_____	_____	_____		
	<u>45</u>	= Total Cover			
Woody Vine Stratum (Plot size: <u>30'</u>)					
1. _____	_____	_____	_____		
2. _____	_____	_____	_____		
3. _____	_____	_____	_____		
4. _____	_____	_____	_____		
	<u>0</u>	= Total Cover			
Remarks: (Include photo numbers here or on a separate sheet.)				Hydrophytic Vegetation Present? Yes <input checked="" type="checkbox"/> No <input type="checkbox"/>	
Photos of the W3 are located in a separate document. Hydrophytic vegetation dominates the plot and the prevalence index is <3.0. Identified grass species present at the site (20%).					

WETLAND DETERMINATION DATA FORM – Northcentral and Northeast Region

Project/Site: Charles River Vegetation Management Plan City/County: Boston Sampling Date: January 24, 2022
 Applicant/Owner: Department of Conservation and Recreation, Commonwealth of Massachusetts State: MA Sampling Point: W1- Upland
 Investigator(s): P. Safran and F. Hoey Section, Township, Range: _____
 Landform (hillslope, terrace, etc.): Summit Local relief (concave, convex, none): Convex Slope (%): 0
 Subregion (LRR or MLRA): LRR-R Lat: 42.359468 Long: -71.157922 Datum: NAD 88
 Soil Map Unit Name: Urban land, wet substratum NWI classification: n/a

Are climatic / hydrologic conditions on the site typical for this time of year? Yes No _____ (If no, explain in Remarks.)
 Are Vegetation _____, Soil , or Hydrology _____ significantly disturbed? Are "Normal Circumstances" present? Yes No _____
 Are Vegetation _____, Soil _____, or Hydrology _____ naturally problematic? (If needed, explain any answers in Remarks.)

SUMMARY OF FINDINGS – Attach site map showing sampling point locations, transects, important features, etc.

Hydrophytic Vegetation Present? Yes <input checked="" type="checkbox"/> No _____ Hydric Soil Present? Yes _____ No <input checked="" type="checkbox"/> Wetland Hydrology Present? <u>Unknown</u> Yes _____ No _____	Is the Sampled Area within a Wetland? Yes _____ No <input checked="" type="checkbox"/> If yes, optional Wetland Site ID: <u>Upland to W1</u>
Remarks: (Explain alternative procedures here or in a separate report.) W-1(Upland) consists of a wooded area located near the bank of the Charles River. The area appears to have been highly disturbed in the past, with presence of asphalt and concrete debris embedded in the soil. Due to the cold weather, soils were frozen and a soil sample for the upland could not be obtained. However with the soils are anticipated to be disturbed and/or potentially fill.	

HYDROLOGY

Wetland Hydrology Indicators: Primary Indicators (minimum of one is required; check all that apply) _____ <input type="checkbox"/> Surface Water (A1) <input type="checkbox"/> Water-Stained Leaves (B9) <input type="checkbox"/> High Water Table (A2) <input type="checkbox"/> Aquatic Fauna (B13) <input type="checkbox"/> Saturation (A3) <input type="checkbox"/> Marl Deposits (B15) <input type="checkbox"/> Water Marks (B1) <input type="checkbox"/> Hydrogen Sulfide Odor (C1) <input type="checkbox"/> Sediment Deposits (B2) <input type="checkbox"/> Oxidized Rhizospheres on Living Roots (C3) <input type="checkbox"/> Drift Deposits (B3) <input type="checkbox"/> Presence of Reduced Iron (C4) <input type="checkbox"/> Algal Mat or Crust (B4) <input type="checkbox"/> Recent Iron Reduction in Tilled Soils (C6) <input type="checkbox"/> Iron Deposits (B5) <input type="checkbox"/> Thin Muck Surface (C7) <input type="checkbox"/> Inundation Visible on Aerial Imagery (B7) <input type="checkbox"/> Other (Explain in Remarks) <input type="checkbox"/> Sparsely Vegetated Concave Surface (B8)	Secondary Indicators (minimum of two required) <input type="checkbox"/> Surface Soil Cracks (B6) <input type="checkbox"/> Drainage Patterns (B10) <input type="checkbox"/> Moss Trim Lines (B16) <input type="checkbox"/> Dry-Season Water Table (C2) <input type="checkbox"/> Crayfish Burrows (C8) <input type="checkbox"/> Saturation Visible on Aerial Imagery (C9) <input type="checkbox"/> Stunted or Stressed Plants (D1) <input type="checkbox"/> Geomorphic Position (D2) <input type="checkbox"/> Shallow Aquitard (D3) <input type="checkbox"/> Microtopographic Relief (D4) <input type="checkbox"/> FAC-Neutral Test (D5)
Field Observations: Surface Water Present? Yes _____ No <input checked="" type="checkbox"/> Depth (inches): _____ Water Table Present? N/A Yes _____ No _____ Depth (inches): _____ Saturation Present? N/A Yes _____ No _____ Depth (inches): _____ (includes capillary fringe)	Wetland Hydrology Present? Yes _____ No <input checked="" type="checkbox"/>
Describe Recorded Data (stream gauge, monitoring well, aerial photos, previous inspections), if available: _____ _____	
Remarks: Due to cold weather, soil was frozen and therefore soil sample was not obtained and presence of water table and saturation was not determined. Assessing the elevation of the upland compared with the wetland W1, it is assumed unlikely the soils would be saturated or have a water table present within the first 12 inches. In addition, the upland plot had no other signs of primary or secondary hydrology indicators.	

VEGETATION – Use scientific names of plants.

Sampling Point: W1- Upland

	Absolute % Cover	Dominant Species?	Indicator Status															
Tree Stratum (Plot size: <u>30'</u>)																		
1. <u>Acer rubrum</u>	<u>40</u>	<u>Yes</u>	<u>FAC</u>	Dominance Test worksheet: Number of Dominant Species That Are OBL, FACW, or FAC: <u>3</u> (A) Total Number of Dominant Species Across All Strata: <u>4</u> (B) Percent of Dominant Species That Are OBL, FACW, or FAC: <u>75</u> (A/B)														
2. <u>Quercus alba</u>	<u>30</u>	<u>Yes</u>	<u>FACU</u>															
3. <u>Quercus rubra</u>	<u>5</u>	<u>No</u>	<u>FACU</u>															
4. _____	_____	_____	_____															
5. _____	_____	_____	_____															
6. _____	_____	_____	_____															
7. _____	_____	_____	_____															
<u>75</u> = Total Cover				Prevalence Index worksheet: <table style="width:100%; border:none;"> <tr> <td style="width:50%; text-align:right;">Total % Cover of:</td> <td style="width:50%; text-align:left;">Multiply by:</td> </tr> <tr> <td>OBL species <u>0</u></td> <td>x 1 = <u>0</u></td> </tr> <tr> <td>FACW species <u>0</u></td> <td>x 2 = <u>0</u></td> </tr> <tr> <td>FAC species <u>70</u></td> <td>x 3 = <u>210</u></td> </tr> <tr> <td>FACU species <u>35</u></td> <td>x 4 = <u>140</u></td> </tr> <tr> <td>UPL species <u>0</u></td> <td>x 5 = <u>0</u></td> </tr> <tr> <td>Column Totals: <u>105</u> (A)</td> <td><u>350</u> (B)</td> </tr> </table> Prevalence Index = B/A = <u>3.33</u>	Total % Cover of:	Multiply by:	OBL species <u>0</u>	x 1 = <u>0</u>	FACW species <u>0</u>	x 2 = <u>0</u>	FAC species <u>70</u>	x 3 = <u>210</u>	FACU species <u>35</u>	x 4 = <u>140</u>	UPL species <u>0</u>	x 5 = <u>0</u>	Column Totals: <u>105</u> (A)	<u>350</u> (B)
Total % Cover of:	Multiply by:																	
OBL species <u>0</u>	x 1 = <u>0</u>																	
FACW species <u>0</u>	x 2 = <u>0</u>																	
FAC species <u>70</u>	x 3 = <u>210</u>																	
FACU species <u>35</u>	x 4 = <u>140</u>																	
UPL species <u>0</u>	x 5 = <u>0</u>																	
Column Totals: <u>105</u> (A)	<u>350</u> (B)																	
Sapling/Shrub Stratum (Plot size: <u>15'</u>)																		
1. <u>Frangula alnus</u>	<u>20</u>	<u>Yes</u>	<u>FAC</u>															
2. <u>Betula alleghaniensis</u>	<u>10</u>	<u>Yes</u>	<u>FAC</u>															
3. _____	_____	_____	_____															
4. _____	_____	_____	_____															
5. _____	_____	_____	_____															
6. _____	_____	_____	_____															
7. _____	_____	_____	_____															
<u>30</u> = Total Cover																		
Herb Stratum (Plot size: <u>5'</u>)																		
1. _____	_____	_____	_____	Hydrophytic Vegetation Indicators: <input type="checkbox"/> 1 - Rapid Test for Hydrophytic Vegetation <input checked="" type="checkbox"/> 2 - Dominance Test is >50% <input type="checkbox"/> 3 - Prevalence Index is ≤3.0 ¹ <input type="checkbox"/> 4 - Morphological Adaptations ¹ (Provide supporting data in Remarks or on a separate sheet) <input type="checkbox"/> Problematic Hydrophytic Vegetation ¹ (Explain)														
2. _____	_____	_____	_____															
3. _____	_____	_____	_____															
4. _____	_____	_____	_____															
5. _____	_____	_____	_____															
6. _____	_____	_____	_____															
7. _____	_____	_____	_____															
8. _____	_____	_____	_____															
9. _____	_____	_____	_____															
10. _____	_____	_____	_____															
11. _____	_____	_____	_____															
12. _____	_____	_____	_____															
<u>0</u> = Total Cover																		
Woody Vine Stratum (Plot size: <u>30'</u>)																		
1. <u>None observed</u>	_____	_____	_____	Definitions of Vegetation Strata: Tree – Woody plants 3 in. (7.6 cm) or more in diameter at breast height (DBH), regardless of height. Sapling/shrub – Woody plants less than 3 in. DBH and greater than or equal to 3.28 ft (1 m) tall. Herb – All herbaceous (non-woody) plants, regardless of size, and woody plants less than 3.28 ft tall. Woody vines – All woody vines greater than 3.28 ft in height.														
2. _____	_____	_____	_____															
3. _____	_____	_____	_____															
4. _____	_____	_____	_____															
<u>0</u> = Total Cover				Hydrophytic Vegetation Present? Yes <u>X</u> No _____														
Remarks: (Include photo numbers here or on a separate sheet.) Prevalence Index is greater than 3.00, however, more than 50% of dominant species are FAC. Area appears to have been historically disturbed.																		

WETLAND DETERMINATION DATA FORM – Northcentral and Northeast Region

Project/Site: Charles River Vegetation Management Plan City/County: Boston Sampling Date: January 24, 2022
 Applicant/Owner: Department of Conservation and Recreation, Commonwealth of Massachusetts State: MA Sampling Point: W1- Wetland
 Investigator(s): P. Safran and F. Hoey Section, Township, Range: _____
 Landform (hillslope, terrace, etc.): Toeslope Local relief (concave, convex, none): Concave Slope (%): 0
 Subregion (LRR or MLRA): LRR-R Lat: 42.35954 Long: -71.157934 Datum: NAD 88
 Soil Map Unit Name: Urban land, wet substratum NWI classification: n/a

Are climatic / hydrologic conditions on the site typical for this time of year? Yes No _____ (If no, explain in Remarks.)
 Are Vegetation _____, Soil , or Hydrology _____ significantly disturbed? Are "Normal Circumstances" present? Yes No _____
 Are Vegetation _____, Soil _____, or Hydrology _____ naturally problematic? (If needed, explain any answers in Remarks.)

SUMMARY OF FINDINGS – Attach site map showing sampling point locations, transects, important features, etc.

Hydrophytic Vegetation Present? Yes <input checked="" type="checkbox"/> No _____ Hydric Soil Present? Yes <input checked="" type="checkbox"/> No _____ Wetland Hydrology Present? Yes <input checked="" type="checkbox"/> No _____	Is the Sampled Area within a Wetland? Yes <input checked="" type="checkbox"/> No _____ If yes, optional Wetland Site ID: <u>Wetland- W1</u>
Remarks: (Explain alternative procedures here or in a separate report.) W-1(Wet) consists of a palustrine scrub-shrub wetland adjacent to storm water drainage channel, near the location where the channel flows into the Charles River. The plot was determined to be located within a wetland due to the presence of all three wetland criteria, including hydric soil, evidence of hydrology, and hydrophytic vegetation dominates at the plot. W1 (Wet) is surrounded by a wooded area along the bank of a river. The area appears to have been highly disturbed in the past.	

HYDROLOGY

Wetland Hydrology Indicators: <u>Primary Indicators (minimum of one is required; check all that apply)</u> ___ Surface Water (A1) <input checked="" type="checkbox"/> Water-Stained Leaves (B9) <input checked="" type="checkbox"/> High Water Table (A2) ___ Aquatic Fauna (B13) <input checked="" type="checkbox"/> Saturation (A3) ___ Marl Deposits (B15) ___ Water Marks (B1) ___ Hydrogen Sulfide Odor (C1) ___ Sediment Deposits (B2) ___ Oxidized Rhizospheres on Living Roots (C3) ___ Drift Deposits (B3) ___ Presence of Reduced Iron (C4) ___ Algal Mat or Crust (B4) ___ Recent Iron Reduction in Tilled Soils (C6) ___ Iron Deposits (B5) ___ Thin Muck Surface (C7) ___ Inundation Visible on Aerial Imagery (B7) ___ Other (Explain in Remarks) ___ Sparsely Vegetated Concave Surface (B8)	<u>Secondary Indicators (minimum of two required)</u> ___ Surface Soil Cracks (B6) <input checked="" type="checkbox"/> Drainage Patterns (B10) ___ Moss Trim Lines (B16) ___ Dry-Season Water Table (C2) ___ Crayfish Burrows (C8) ___ Saturation Visible on Aerial Imagery (C9) ___ Stunted or Stressed Plants (D1) <input checked="" type="checkbox"/> Geomorphic Position (D2) ___ Shallow Aquitard (D3) ___ Microtopographic Relief (D4) ___ FAC-Neutral Test (D5)
Field Observations: Surface Water Present? Yes _____ No <input checked="" type="checkbox"/> Depth (inches): _____ Water Table Present? Yes <input checked="" type="checkbox"/> No _____ Depth (inches): <u>7"</u> Saturation Present? Yes <input checked="" type="checkbox"/> No _____ Depth (inches): <u>0"</u> (includes capillary fringe)	Wetland Hydrology Present? Yes <input checked="" type="checkbox"/> No _____
Describe Recorded Data (stream gauge, monitoring well, aerial photos, previous inspections), if available: _____ _____	
Remarks: Both primary and secondary indicators of hydrology were observed at the W1 (Wet) plot.	

VEGETATION – Use scientific names of plants.

Sampling Point: W1- Wetland

Tree Stratum (Plot size: <u>30'</u>)	Absolute % Cover	Dominant Species?	Indicator Status															
1. _____	_____	_____	_____	Dominance Test worksheet: Number of Dominant Species That Are OBL, FACW, or FAC: <u>3</u> (A) Total Number of Dominant Species Across All Strata: <u>3</u> (B) Percent of Dominant Species That Are OBL, FACW, or FAC: <u>100</u> (A/B)														
2. _____	_____	_____	_____															
3. _____	_____	_____	_____															
4. _____	_____	_____	_____															
5. _____	_____	_____	_____															
6. _____	_____	_____	_____															
7. _____	_____	_____	_____															
<u>0</u> = Total Cover				Prevalence Index worksheet: <table style="width:100%; border:none;"> <tr> <td style="width:50%; text-align:right;">Total % Cover of:</td> <td style="width:50%; text-align:left;">Multiply by:</td> </tr> <tr> <td>OBL species <u>0</u></td> <td>x 1 = <u>0</u></td> </tr> <tr> <td>FACW species <u>7</u></td> <td>x 2 = <u>14</u></td> </tr> <tr> <td>FAC species <u>70</u></td> <td>x 3 = <u>210</u></td> </tr> <tr> <td>FACU species <u>0</u></td> <td>x 4 = <u>0</u></td> </tr> <tr> <td>UPL species <u>0</u></td> <td>x 5 = <u>0</u></td> </tr> <tr> <td>Column Totals: <u>77</u> (A)</td> <td><u>224</u> (B)</td> </tr> </table> Prevalence Index = B/A = <u>2.91</u>	Total % Cover of:	Multiply by:	OBL species <u>0</u>	x 1 = <u>0</u>	FACW species <u>7</u>	x 2 = <u>14</u>	FAC species <u>70</u>	x 3 = <u>210</u>	FACU species <u>0</u>	x 4 = <u>0</u>	UPL species <u>0</u>	x 5 = <u>0</u>	Column Totals: <u>77</u> (A)	<u>224</u> (B)
Total % Cover of:	Multiply by:																	
OBL species <u>0</u>	x 1 = <u>0</u>																	
FACW species <u>7</u>	x 2 = <u>14</u>																	
FAC species <u>70</u>	x 3 = <u>210</u>																	
FACU species <u>0</u>	x 4 = <u>0</u>																	
UPL species <u>0</u>	x 5 = <u>0</u>																	
Column Totals: <u>77</u> (A)	<u>224</u> (B)																	
Sapling/Shrub Stratum (Plot size: <u>15'</u>)				Hydrophytic Vegetation Indicators: <input type="checkbox"/> 1 - Rapid Test for Hydrophytic Vegetation <input checked="" type="checkbox"/> 2 - Dominance Test is >50% <input checked="" type="checkbox"/> 3 - Prevalence Index is ≤3.0 ¹ <input type="checkbox"/> 4 - Morphological Adaptations ¹ (Provide supporting data in Remarks or on a separate sheet) <input type="checkbox"/> Problematic Hydrophytic Vegetation ¹ (Explain)														
1. <u>Acer rubrum</u>	<u>40</u>	<u>Yes</u>	<u>FAC</u>															
2. <u>Frangula alnus</u>	<u>20</u>	<u>Yes</u>	<u>FAC</u>															
3. <u>Betula alleghaniensis</u>	<u>10</u>	<u>No</u>	<u>FAC</u>															
4. <u>Swida amomum</u>	<u>2</u>	<u>No</u>	<u>FACW</u>															
5. _____	_____	_____	_____															
6. _____	_____	_____	_____															
7. _____	_____	_____	_____															
<u>72</u> = Total Cover				Definitions of Vegetation Strata: Tree – Woody plants 3 in. (7.6 cm) or more in diameter at breast height (DBH), regardless of height. Sapling/shrub – Woody plants less than 3 in. DBH and greater than or equal to 3.28 ft (1 m) tall. Herb – All herbaceous (non-woody) plants, regardless of size, and woody plants less than 3.28 ft tall. Woody vines – All woody vines greater than 3.28 ft in height. Hydrophytic Vegetation Present? Yes <u>X</u> No _____														
Herb Stratum (Plot size: <u>5'</u>)																		
1. <u>Impatiens pallida</u>	<u>5</u>	<u>Yes</u>	<u>FACW</u>															
2. _____	_____	_____	_____															
3. _____	_____	_____	_____															
4. _____	_____	_____	_____															
5. _____	_____	_____	_____															
6. _____	_____	_____	_____															
7. _____	_____	_____	_____															
8. _____	_____	_____	_____															
9. _____	_____	_____	_____															
10. _____	_____	_____	_____															
11. _____	_____	_____	_____															
12. _____	_____	_____	_____															
<u>5</u> = Total Cover																		
Woody Vine Stratum (Plot size: <u>30'</u>)																		
1. _____	_____	_____	_____															
2. _____	_____	_____	_____															
3. _____	_____	_____	_____															
4. _____	_____	_____	_____															
<u>0</u> = Total Cover																		
Remarks: (Include photo numbers here or on a separate sheet.) Photos of the W1 are located in a separate document.																		

Alternatives Analysis

As required by the General Performance Standards for Riverfront Area at 310 CMR 10.58(4)(c)(1-3), there must be no practicable and substantially equivalent economic alternative to the proposed Project with less adverse effect on the interests identified in MGL c. 131 s 40. An alternative is practicable and substantially equivalent economically if it is available and capable of being done after taking into consideration costs, existing technology, proposed use, and logistics, in light of overall Project purposes. “Available and capable of being done” means the alternative is attainable and feasible.

Based on the alternative analysis herein, it has been determined that, in light of the Project’s goals, no practicable and substantially equivalent economic alternative to the current proposed project exists with less adverse effects on the interests identified in the Wetland’s Protection Act and the Boston City Ordinance, or DCR’s Mission, habitat enhancement initiatives and the future vision of vegetation management along the Charles River. DCR’s vision for the Charles River includes the implementation of a vegetation management plan that addresses the following goals:

1. Restore a healthy riverbank ecology that provides for stable and sustainable shorelines, beautiful vistas, climate resiliency, and a safe, stable tree canopy;
2. Provide public access to outstanding opportunities for passive and active recreation along and adjacent to the riverbank;
3. Steward parklands that reflect the cultural value and 100- year history of the Charles River Reservation;
4. Engage a cooperative network of parkland stakeholders who both enjoy the many recreational opportunities and provide volunteer assistance in managing the CRVMP area; and
5. Provide a framework to guide future capital restoration projects.

5.1 Overall Project Purpose

Head of the Charles Regatta

To provide views of the Charles River during the Head of the Charles Regatta for the public, regatta participants and public safety personnel. The Head of the Charles is held in the same location every year, starting at the Boston University(BU) DeWolfe Boathouse and ending at in Herter Park. This year will be the 57th anniversary of the regatta. In the future, DCR will manage vegetation along the Charles in accordance with the CRVMP (to be approved by the Boston Conservation Commission and other municipalities).

Fourth of July Ceremony

To provide views and safe access for the public for the Fourth of July celebration. This is a City event that has taken place since 1973, when David Mugar conceived of energizing the Boston Pops Esplanade concert with Tchaikovsky’s 1812 Overture, cannons, and fireworks. Similar to the Head of the Charles Regatta, management for this event includes trimming of vegetation along the River’s Edge.

General DCR Parks Maintenance

DCR is required to maintain the Charles River Reservation lands to maintain recreation use, accessibility of pathways and public space, health of specific ecosystems, scenic vistas, landscaping, etc. There are eight different Landscape Types that require specific levels of management on specific types of vegetation. See Section 5.1 of the Boston Notice of Intent submission narrative for details on the management within each Landscape Type.

Invasive Plant Management

DCR has defined four Focus Areas for invasive plant management within the Charles River Reservation. Throughout the course of the proposed project, DCR will prioritize both invasive plant management and eradication as well as native plant restoration to increase climate resilience and improve native species habitat within the Charles River Reservation in the City of Boston.

5.2 Alternatives Considered

5.2.1 No Management Scenario

Charles River Regatta and Fourth of July Cutting (Special Events)

The no-trim scenario is not practical as it does not meet the goals of the Project. Furthermore, these events have been taking place for about 50 years and River's Edge trimming is a necessary aspect of event preparation. However, DCR does plan to systematically restore riparian areas across the Reservation to reduce the need for continued future River's Edge trimming and increase the stability and overall resilience of the Bank to the Charles River. This is a long-term plan and will not be able to be implemented immediately.

General DCR Parks Maintenance

A no-maintenance scenario is not feasible for DCR parklands. DCR is required to provide safe and equitable access to the Charles River Reservation. In order to provide the intended active and passive recreation within the Reservation, DCR needs to maintain vegetation. This includes some degree of management regulated wetland resource areas.

Invasive Plant Management

The no management scenario for invasive plant management is not a feasible option the native ecological integrity of the Reservation. Invasive plants will continue to spread and populate in currently uninfested areas of the Reservation and the greater community without management. This will reduce available native species habitat, create monocultures of non-native invasive plants, and result in the reduction and potentially elimination of rare and native plant species throughout the reservation.

5.2.2 Full Impact Management Scenario

Charles River Regatta and Fourth of July Cutting (Special Events)

This scenario would involve cutting all vegetation as flush to the ground as possible along the entire length of the full extent of both special event cutting areas (Appendix C). Although this scenario would provide the most visibility for the public, participants, and emergency personnel, it also results in the significant impacts to bank and riverfront area. This scenario is also not compatible with the DCR mission and its efforts to balance conservation and recreation.

General DCR Parks Maintenance

This scenario allows for the continuation of general maintenance as is required for the safety and accessibility needs of the Reservation. This would result in continued mowing at the historic frequencies and trimming, pruning, and cutting of vegetation as-needed. While some of these activities are assuredly required for park maintenance, there are some areas that DCR may be able to reduce maintenance activities through native restoration. One goal of the CRVMP is to work toward a more climate-resilient landscape management strategy.

Invasive Plant Management

DCR views a full-impact invasive plant management strategy as utilizing a single management method, such as excavation, herbicide application across the entirety of the Reservation. This is not an ecologically sound means of invasive plant management, nor is it often effective. The overall goal of invasive plant management is not only to eradicate non-native invasive plant species from the Reservation, but also to restore with native vegetation.

Large-scale mechanical or manual removal of vegetation would destabilize areas of the Reservation (particularly concerning in Bank and riparian areas) and result in fresh disturbance of soil, which could easily be established by additional aggressive invasive plant species. Similarly, utilizing only herbicide application throughout the entire reservation without selectivity could result in non-target impacts and slow the natural restoration of managed areas. Neither of these options are an ecologically suitable approach.

5.2.3 Adaptive Management and Systematic Restoration (Chosen for All Management Categories)

Charles River Regatta and Fourth of July Cutting (Special Events)

This scenario would involve cutting all target vegetation at a height of 24 inches along the entire length of the Special Events trimming areas (Appendix C). This scenario requires that vegetation management staff selectively trim nuisance and invasive plant material within the Special Event trimming locations and avoid both stands of native vegetation, as well as any vegetation with signs of wildlife use. This selective and adaptive trimming technique will allow for the lowest ecological impact.

Furthermore, DCR will systematically restore Bank and riparian areas throughout the course of the proposed project. Prioritization will be given to areas with existing high erosion potential and/or areas with nuisance and invasive plant presence. Restored vegetation will be chosen to be resilient, hardy, and require little to no management in future Special Event preparations. DCR is encouraging the growth of native vegetation in all DCR facilities as part of the Department's Growing Wild Initiative.

General DCR Parks Maintenance

The adaptive management and systematic restoration of general maintenance throughout the Reservation entails identification of under-utilized lawn areas (areas that do not get much public use and do not need to be maintained as lawn). Once identified, these underutilized lawn areas will be restored into native meadows and require only once-annual mowing. Meadow habitat is limited in the Commonwealth, particularly in the greater Boston area, and these restored areas will greatly increase the wildlife habitat value of the Reservation as a whole.

Systematic restoration of riparian areas is another large component of this scenario of general maintenance. The installation of resilient native vegetation will improve the ecological integrity of riparian areas throughout the Reservation and decrease the need for frequent landscaped area, river's edge, and other landscape type management. These restoration activities align with DCR's goals for the CRVMP and broader parkland management and will not negatively effect the safety and utility of the parkland to the public.

Invasive Plant Management

Adaptive plant management is extremely key to effective invasive plant management. No single management method is both effective and ecologically sound over the entire span of a management

program. Invasive plants are dynamic and require different methods of management at different stages of growth, population size, time of year, ecological setting, etc. This scenario of invasive plant management involves assessing the invasive plant as well as its environment and overall population to determine the best management technique needed in any given year. It is critical that this be able to adapt and change with changing scenarios. Furthermore, restoration is a key component of this scenario. Whether by natural regeneration or active seeding and planting, invasive plant management cannot be successful without restoration of native vegetation.

APPENDIX B

Abutter Notification Letters



**NOTIFICATION TO ABUTTERS
BOSTON CONSERVATION COMMISSION**

In accordance with the Massachusetts Wetlands Protection Act, Massachusetts General Laws Chapter 131, Section 40, and the Boston Wetlands Ordinance, you are hereby notified as an abutter to a project filed with the Boston Conservation Commission.

A. The Department of Conservation and Recreation has filed a Notice of Intent with the Boston Conservation Commission seeking permission to alter an Area Subject to Protection under the Wetlands Protection Act (General Laws Chapter 131, section 40) and Boston Wetlands Ordinance.

B. The address of the lot where the activity is proposed is the Charles River Reservation in the City of Boston.

C. The project involves the Charles River Vegetation Management Plan (special event cutting, general maintenance, and invasive plant management).

D. Copies of the Notice of Intent may be obtained by contacting the Boston Conservation Commission at CC@boston.gov.

E. Copies of the Notice of Intent may be obtained from SWCA Environmental Consultants by contacting them at 416-256-0202 between the hours of 9:00 a.m., 5:00 p.m..

F. In accordance with the Chapter 20 of the Acts of 2021, the public hearing will take place **virtually** at <https://zoom.us/j/6864582044>. If you are unable to access the internet, you can call 1-929-205-6099, enter Meeting ID 686 458 2044 # and use # as your participant ID.

G. Information regarding the date and time of the public hearing may be obtained from the **Boston Conservation Commission** by emailing CC@boston.gov or calling **(617) 635-3850** between the hours of **9 AM to 5 PM, Monday through Friday**.

NOTE: Notice of the public hearing, including its date, time, and place, will be published at least five (5) days in advance in the **Boston Herald**.

NOTE: Notice of the public hearing, including its date, time, and place, will be posted on www.boston.gov/public-notices and in Boston City Hall not less than forty-eight (48) hours in advance. If you would like to provide comments, you may attend the public hearing or send written comments to CC@boston.gov or Boston City Hall, Environment Department, Room 709, 1 City Hall Square, Boston, MA 02201

NOTE: If you would like to provide comments, you may attend the public hearing or send written comments to CC@boston.gov or Boston City Hall, Environment Department, Room 709, 1 City Hall Square, Boston, MA 02201

NOTE: You also may contact the Boston Conservation Commission or the Department of Environmental Protection Northeast Regional Office for more information about this application or the Wetlands Protection Act. To contact DEP, call: the Northeast Region: (978) 694-3200.

NOTE: If you plan to attend the public hearing and are in need of interpretation, please notify staff at CC@boston.gov by 12 PM the day before the hearing.



NOTIFICACIÓN PARA PROPIETARIOS Y/O VECINOS COLINDANTES COMISIÓN DE CONSERVACIÓN DE BOSTON

De conformidad con la Ley de protección de los humedales de Massachusetts, el Capítulo 131, Sección 40 de las Leyes Generales de Massachusetts y la Ordenanza sobre los humedales de Boston, por la presente queda usted notificado como propietario o vecino colindante de un proyecto presentado ante la Comisión de Conservación de Boston.

- A. El Departamento de Conservación y Recreación ha presentado una solicitud a la Comisión de Conservación de Boston pidiendo permiso para modificar una zona sujeta a protección en virtud de la Ley de protección de los humedales (Leyes generales, capítulo 131, sección 40) y la Ordenanza sobre los humedales de Boston.
- B. La dirección del lote donde se propone la actividad es la Reserva de Charles River en la Ciudad de Boston.
- C. El proyecto consiste en: el Plan de Administración de Vegetación de Charles River (corte para eventos especiales, administración general y administración de plantas invasoras).
- D. Se pueden obtener copias del Aviso de Intención comunicándose con la Comisión de Conservación de Boston en CC@boston.gov.
- E. Las copias de la notificación de intención pueden obtenerse de SWCA Environmental Consultants llamando al 416-256-0202 entre las 9 AM y las 5 PM.
- F. De acuerdo con el Decreto Ejecutivo de la Mancomunidad de Massachusetts que suspende ciertas disposiciones de la Ley de reuniones abiertas, la audiencia pública se llevará a cabo virtualmente en <https://zoom.us/j/6864582044>. Si no puede acceder a Internet, puede llamar al 1-929-205-6099, ingresar ID de reunión 686 458 2044 # y usar # como su ID de participante.
- G. La información relativa a la fecha y hora de la audiencia pública puede solicitarse a la **Comisión de Conservación de Boston** por correo electrónico a CC@boston.gov o llamando al **(617) 635-4416** entre las **9 AM y las 5 PM, de lunes a viernes**.

NOTA: La notificación de la audiencia pública, incluida su fecha, hora y lugar, se publicará en el **Boston Herald** con al menos cinco (5) días de antelación.

NOTA: La notificación de la audiencia pública, incluida su fecha, hora y lugar, se publicará en www.boston.gov/public-notices y en el Ayuntamiento de Boston con no menos de cuarenta y ocho (48) horas de antelación. Si desea formular comentarios, puede asistir a la audiencia pública o enviarlos por escrito a CC@boston.gov o al Ayuntamiento de Boston, Departamento de Medio Ambiente, Sala 709, 1 City Hall Square, Boston, MA 02201.

NOTA: También puede comunicarse con la Comisión de Conservación de Boston o con la Oficina Regional del Noreste del Departamento de Protección Ambiental para obtener más información sobre esta solicitud o la Ley de Protección de Humedales. Para comunicarse con el DEP, llame a la Región Noreste: (978) 694-3200.

NOTA: si tiene previsto asistir a la audiencia pública y necesita servicios de interpretación, sírvase informar al personal en CC@boston.gov antes de las 12 PM del día anterior a la audiencia.

CERTIFICATE OF GOOD FAITH ACCURACY OF TRANSLATION

I, Río Hernández, do hereby state:

That a translator officially affiliated with the Translation Center at the University of Massachusetts Amherst and competent in both **English** and **Spanish** has made a good faith translation of the attached documents,

Notification to Abutters for a project filed with the Boston Conservation Commission by the Department of Conservation and Recreation involving the Charles River Vegetation Management Plan

From English to Spanish
(source language) (target language)

I hereby certify that the same is a true and complete translation to the best of my knowledge, ability and belief.

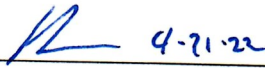
 4-21-22
Río Hernández, Project Manager
Translation Center
University of Massachusetts Amherst



波士顿湿地保护委员会 项目邻近住户通知

根据《马萨诸塞州湿地保护法》、《马萨诸塞州普通法》第 131 章第 40 节以及《波士顿湿地条例》的规定，我们特此向您，即向波士顿湿地保护委员会提出申请的项目的邻近住户，发出以下通知。

- A. 环境保护和休闲利用部已向波士顿湿地保护委员会提出申请，请求批准改建一块受《湿地保护法》（《普通法》第 131 章第 40 节）和《波士顿湿地条例》保护的地块。
- B. 拟开展改建活动的地块地址为：波士顿市查尔斯河保护区。
- C. 该项目涉及以下建设内容：查尔斯河植被管理计划（特别活动植被修剪、常规维护和入侵植物管理）。
- D. 可通過聯繫波士頓保護委員會取得意向通知書的副本，電子郵件是CC@boston.gov。
- E. 您可于早9点至晚5点，联系SWCA 环境咨询服务处，获取意向通知的副本，电话：416-256-0202。
- F. 根據《馬薩諸塞州行政命令》（暫緩執行《公開會議法》聽證會將在網上<https://zoom.us/j/6864582044> 進行。如果無法上互聯網(Internet)，則可致電 1-929-205-6099，輸入會議編號(ID) 686 458 2044 #，然後使用 # 作為您參與的編號 (ID.)
- G. 您可于周一至周五上午 9 点到下午 5 点联系波士顿湿地保护委员会，咨询公开听证会举行的日期和时间，邮箱地址：CC@boston.gov，电话：(617) 635-4416。

注：公开听证会的通知（包括其举行日期、时间和地点）将提前至少五天在《波士顿先驱报》上予以公布。

注：公开听证会的通知（包括其举行日期、时间和地点）将提前至少四十八（48）小时发布在以下网页之上以及波士顿市政厅内：www.boston.gov/public-notices。如果您想提出意见或建议，您可以参加该公开听证会或将书面形式的意见或建议发送至 CC@boston.gov 或邮寄至以下地址：Boston City Hall, Environment Department, Room 709, 1 City Hall Square, Boston, MA 02201。

注：您也可以联系波士顿湿地保护委员会或环境保护部东北地区办公室，咨询有关此项申请或《湿地保护法》的更多信息。如要联系环境保护部，请致电：东北地区：（978）694-3200。

注：如果您准备参加该公开听证会并需要口译服务，则请在听证会举行前一天中午 12 点前通过以下电子邮箱地址告知工作人员：CC@boston.gov。

CERTIFICATE OF GOOD FAITH ACCURACY OF TRANSLATION

I, Río Hernández, do hereby state:

That a translator officially affiliated with the Translation Center at the University of Massachusetts Amherst and competent in both **English** and **Chinese** has made a good faith translation of the attached documents,

Notification to Abutters for a project filed with the Boston Conservation Commission by the Department of Conservation and Recreation involving the Charles River Vegetation Management Plan

From English to Chinese.
(source language) (target language)

I hereby certify that the same is a true and complete translation to the best of my knowledge, ability and belief.

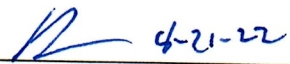

Río Hernández, Project Manager
Translation Center
University of Massachusetts Amherst



BABEL NOTICE

English:

IMPORTANT! This document or application contains **important information** about your rights, responsibilities and/or benefits. It is crucial that you understand the information in this document and/or application, and we will provide the information in your preferred language at no cost to you. If you need them, please contact us at cc@boston.gov or 617-635-3850.

Spanish:

¡IMPORTANTE! Este documento o solicitud contiene **información importante** sobre sus derechos, responsabilidades y/o beneficios. Es fundamental que usted entienda la información contenida en este documento y/o solicitud, y le proporcionaremos la información en su idioma preferido sin costo alguno para usted. Si los necesita, póngase en contacto con nosotros en el correo electrónico cc@boston.gov o llamando al 617-635-3850.

Haitian Creole:

AVI ENPÒTAN! Dokiman oubyen aplikasyon sa genyen **enfòmasyon ki enpòtan** konsènan dwa, responsablite, ak/oswa benefis ou yo. Li enpòtan ke ou konprann enfòmasyon ki nan dokiman ak/oubyen aplikasyon sa, e n ap bay enfòmasyon an nan lang ou prefere a, san ou pa peye anyen. Si w bezwen yo, tanpri kontakte nou nan cc@boston.gov oswa 617-635-3850.

Traditional Chinese:

非常重要！這份文件或是申請表格包含關於您的權利，責任，和／或福利的重要信息。請您務必完全理解這份文件或申請表格的全部信息，這對我們來說十分重要。我們會免費給您提供翻譯服務。如果您有需要請聯系我們的郵箱 cc@boston.gov 電話# 617-635-3850..

Vietnamese:

QUAN TRỌNG! Tài liệu hoặc đơn yêu cầu này chứa **thông tin quan trọng** về các quyền, trách nhiệm và/hoặc lợi ích của bạn. Việc bạn hiểu rõ thông tin trong tài liệu và/hoặc đơn yêu cầu này rất quan trọng, và chúng tôi sẽ cung cấp thông tin bằng ngôn ngữ bạn muốn mà không tính phí. Nếu quý vị cần những dịch vụ này, vui lòng liên lạc với chúng tôi theo địa chỉ cc@boston.gov hoặc số điện thoại 617-635-3850.

Simplified Chinese:

非常重要！这份文件或是申请表格包含关于您的权利，责任，和／或福利的重要信息。请您务必完全理解这份文件或申请表格的全部信息，这对我们来说十分重要。我们会免费给您提供翻译服务。如果您有需要请联联系我们的邮箱 cc@boston.gov 电话# 617-635-3850.

Cape Verdean Creole:

INPURTANTI! Es dukumentu ó aplikason ten **informason inpur tanti** sobri bu direitus, rasponsabilidadi i/ó benefisius. Ê krusial ki bu intendi informason na es dukumentu i/ó aplikason ó nu ta da informason na língua di bu preferênsia sen ninhun kustu pa bó. Si bu prisiza del, kontata-nu na cc@boston.gov ó 617-635-3850.

Arabic:

مهم! يحتوي هذا المستند أو التطبيق على معلومات مهمة حول حقوقك ومسؤولياتك أو فوائدك. من الأهمية أن تفهم المعلومات الواردة في هذا المستند أو التطبيق. سوف نقدم المعلومات بلغتك المفضلة دون أي تكلفة عليك. إذا كنت في حاجة إليها، يرجى الاتصال بنا على cc@boston.gov أو 617-635-3850.

Russian:

ВАЖНО! В этом документе или заявлении содержится **важная информация** о ваших правах, обязанностях и/или льготах. Для нас очень важно, чтобы вы понимали приведенную в этом документе и/или заявлении информацию, и мы готовы бесплатно предоставить вам информацию на предпочитаемом вами языке. Если Вам они нужны, просьба связаться с нами по адресу электронной почты cc@boston.gov, либо по телефону 617-635-3850.

Portuguese:

IMPORTANTE! Este documento ou aplicativo contém **Informações importantes** sobre os seus direitos, responsabilidades e/ou benefícios. É importante que você compreenda as informações contidas neste documento e/ou aplicativo, e nós iremos fornecer as informações em seu idioma de preferência sem nenhum custo para você. Se precisar deles, fale conosco: cc@boston.gov ou 617-635-3850.

French:

IMPORTANT ! Ce document ou cette demande contient des **informations importantes** concernant vos droits, responsabilités et/ou avantages. Il est essentiel que vous compreniez les informations contenues dans ce document et/ou cette demande, que nous pouvons vous communiquer gratuitement dans la langue de votre choix. Si vous en avez besoin, veuillez nous contacter à cc@boston.gov ou au 617-635-3850.



THE RED THERMO SECURED "SP" LOGO IN THE LOWER CORNER OF THIS CHECK MUST FADE TEMPORARILY WHEN WARMED BY TOUCH OR FRICTION. SEE BACK FOR ADDITIONAL FEATURES.

SWCA, INC.
IMPREST ACCOUNT
15 RESEARCH DRIVE
AMHERST, MA 01002

DATE 4/20/2022 020214
11-24/1210

PAY TO THE ORDER OF The City of Boston \$ 300.00

Three hundred and 00/100 DOLLARS



MEMO 70690/02/2.4 NO1

[Signature]



THE RED THERMO SECURED "SP" LOGO IN THE LOWER CORNER OF THIS CHECK MUST FADE TEMPORARILY WHEN WARMED BY TOUCH OR FRICTION. SEE BACK FOR ADDITIONAL FEATURES.

SWCA, INC.
IMPREST ACCOUNT
15 RESEARCH DRIVE
AMHERST, MA 01002

DATE 4/20/2022 020215
11-24/1210

PAY TO THE ORDER OF The City of Boston \$ 1,500.00

One thousand Five hundred and 00/100 DOLLARS



MEMO 70690/02/2.4 NO1 Fee

[Signature]



300-foot Abutters List - Exported from <https://www.boston.gov/abutter-mailing-list-generator>

PID	FULL_ADDRESS	CITY	ZIPCODE	OWNER	ADDRESSEE	MAIL_ADDRESS	MAIL_CS	STATE	MAIL_ZIP
0503710000	12 13 BAY STATE RD	BOSTON	2215	12 BAY STATE RD LLC	C/O DARROWEVERETT LLP	197 PORTLAND ST 4TH FLR	BOSTON	MA	2114
2200550000	1200 SOLDIERS FIELD RD	ALLSTON	2134	1200 SFR LLC		1200 SOLDIERS FIELD RD STE #102	ALLSTON	MA	2134
0502537000	132 CHESTNUT ST	BOSTON	2108	132 CHESTNUT STREET REALTY TRUST	STEPHANIE S FLETCHER	132 CHESTNUT ST	BOSTON	MA	2108
0502803000	135 BEACON ST	BOSTON	2116	135 BEACON STREET LLC		590 MAIN ST STE 500	WATERTOWN	MA	2472
2200677002	14 LINCOLN ST	BRIGHTON	2135	14 LINCOLN STREET REALTY TRUST		42 KENDRICK ST, UNIT 1	BRIGHTON	MA	2135
0502426000	16 BRIMMER ST	BOSTON	2108	16 BRIMMER STREET CONDO TRUST		16 BRIMMER ST	BOSTON	MA	2108
0504066000	187 BAY STATE RD	BOSTON	2215	187 BAY STATE ROAD LLC		295 ENDICOTT AVE	REVERE	MA	2151
0502733000	187 BEACON ST	BOSTON	2116	187 BEACON STREET	C/O 187 BEACON STREET LLC	44 SCHOOL ST 9TH FL	BOSTON	MA	2108
0502612000	204 BEACON ST	BOSTON	2116	204 BEACON STREET		204 BEACON ST	BOSTON	MA	2116
0502617000	214 BEACON ST 2	BOSTON	2116	214 BEACON LLC		214 BEACON ST #3	BOSTON	MA	2116
0502619000	220 BEACON ST	BOSTON	2116	220 BEACON STREET LLC		220 BEACON ST	BOSTON	MA	2116
0502691000	233 BEACON ST	BOSTON	2116	233 BEACON STREET LLC		421 HANOVER STREET	BOSTON	MA	2113
0503284000	314 BEACON ST 3-Feb	BOSTON	2116	314 BEACON ST LLC NEVADA LLC	C/O LARAIN LEVY	14 SOMERSET PLACE	WESTON	MA	2493
0502491000	3 4 W HILL PL	BOSTON	2114	3-4 WEST HILL PLACE CONDO TRUST		3-4 W HILL PL	BOSTON	MA	2114
0503487000	350 BEACON ST	BOSTON	2116	350 BEACON STREET LLC	C/O CAPITOL REALTY GROUP INC	80 CHARLES ST	BOSTON	MA	2114
0503495000	398 BEACON ST 1	BOSTON	2116	398 BEACON STREET NOMINEE TRUST		398 BEACON ST, UNIT 1	BOSTON	MA	2116
0502527000	4 OTIS PL	BOSTON	2108	4 OTIS LLC		267 COMMONWEALTH AV STE A	BOSTON	MA	2116
2200102000	400 SOLDIERS FIELD RD	ALLSTON	2134	400 SOLDIERS FIELD RD	C/O HILTON HOTEL CORP:TAX DEPT	755 CROSSOVER LANE	MEMPHIS	TN	38117
0503526000	401 BEACON ST 2	BOSTON	2115	401 BEACON CONDOMINIUM TRUST		401 BEACON ST	BOSTON	MA	2115
0503499000	408 BEACON ST PS-3	BOSTON	2115	408 HEXAGON LLC		119 HYSLOP RD	BROOKLINE	MA	2445
0503650000	469 BEACON ST	BOSTON	2115	469 BEACON LLC	C/O CONCENTRIC MGMT LLC	475 COMMONWEALTH AVE #105	BOSTON	MA	2215
2202749000	1850 SOLDIERS FIELD RD	BRIGHTON	2135	4725 COMPANY LLC		25060 AVENUE STANFORD SUITE 200	VALENCIA	CA	91355
0503648000	473 BEACON ST 4	BOSTON	2115	473 BEACON LLC		473 BEACON ST, UNIT 4	BOSTON	MA	2115
0503683000	474 BEACON ST	BOSTON	2115	474 BEACON CONDOMINIUM TRUST	C/O FRONT BAY LLC	22 BRIMMER STREET	BOSTON	MA	2108
2200595000	WESTERN AV	BRIGHTON	2135	500 WESTERN AVENUE LLC	C/O WESTERN AVENUE LLC	500 WESTERN AV	BRIGHTON	MA	2135
0502529000	57 BRIMMER ST	BOSTON	2108	55-57 BRIMMER STREET REAL ESTATE LI	C/O LEVIN REALTY GROUP LLC	30 ELM STREET #1	CHARLESTOWN	MA	2129
0502485000	7 W HILL PL	BOSTON	2114	7 WEST HILL PLACE LLC		7 W HILL PL	BOSTON	MA	2114
2200677001	14 LINCOLN ST	BRIGHTON	2135	70 LEO OWNER LLC		1900 CROWN COLONY DR, UNIT STE 405	Quincy	MA	
0502552000	89 BEACON ST 2	BOSTON	2108	89 BEACON STREET REALTY TRUST		31 SOMERSET RD	LEXINGTON	MA	2420
2202765000	270 PARSONS ST	BRIGHTON	2135	A FRED WASHINGTON NOMINEE TRUST	C/O FRED STARIKOV	320 WASHINGTON ST #3FF	BROOKLINE	MA	2445
0503300000	335 BEACON ST	BOSTON	2116	AAA BOSTON RE LLC		120 MILK ST SUITE #200	BOSTON	MA	2109
0502639001	270 BEACON ST C	BOSTON	2116	ACKERMAN ROBERT W		270 BEACON ST #C	BOSTON	MA	2116
2200690000	7 7A LOTHROP ST	BRIGHTON	2135	ADAMS FRANCES D		7A LOTHROP ST	BRIGHTON	MA	2135
0502410000	3 MT VERNON SQ	BOSTON	2108	ADS PROPERTY MANAGEMENT LLC	C/O DONNA TRITMAN	581 BOYLSTON ST STE 804A	BOSTON	MA	2116
0502504000	15 BRIMMER ST	BOSTON	2108	ADVENT SCHOOL CORP		17 BRIMMER ST	BOSTON	MA	2108
0502809000	121 BEACON ST 5	BOSTON	2116	AGGARWAL SARIKA		121 BEACON ST #5	BOSTON	MA	2116
0502630000	242 BEACON ST 8	BOSTON	2116	AIDA TRUST		242 BEACON ST, UNIT 8	BOSTON	MA	2116
0300450000	6 8 WHITTIER PL PS 308	BOSTON	2114	ALACHI CLAUDETTE		6 WHITTIER PL 4N-6	BOSTON	MA	2114
0503515000	423 BEACON ST 2	BOSTON	2115	ALAIMO ALISHA A		423 BEACON ST #2	BOSTON	MA	2115
2200562010	180 TELFORD ST PS-149	BRIGHTON	2135	ALEMIAN ANDREW		180 TELFORD ST, UNIT 602	BRIGHTON	MA	2135
0502394000	100 CHARLES ST 5	BOSTON	2114	ALK FAMILY TRUST	C/O GENNADIY KRAVETS	51 SHAFFER RD	BRIDGEWATER	NJ	8807
0503702000	532 BEACON ST	BOSTON	2215	ALPHA THETA CHAPTER SIGMA	C/O JOSHUA B LITTLEFIELD	44 BOULDER BROOK RD	WELLESLEY	MA	2481
0503501000	412 BEACON ST 5	BOSTON	2115	ANDELMAN ESTELLE		412 BEACON ST #5	BOSTON	MA	2116
0502506000	19 BRIMMER ST 4	BOSTON	2108	ANDREW J COCKERILL 2019 REVOCABLE TRUST		19 BRIMMER ST, UNIT 4	BOSTON	MA	2108
0502732000	189 BEACON ST 5	BOSTON	2116	ANGUITA ANTONIO		189 BEACON ST #7	BOSTON	MA	2116
0502622000	226 BEACON ST 3	BOSTON	2116	ANKNER TERENCE K	C/O TERENCE ANKNER	226 BEACON ST #3	BOSTON	MA	2116
0502703000	209 BEACON ST	BOSTON	2116	ANTEBLIAN GEORGE ETAL		209 BEACON	BOSTON	MA	2116
0502625000	232 BEACON ST	BOSTON	2116	AROSTEGUI - HAM VIVIANA TS		232 BEACON	BOSTON	MA	2116
0503888000	495 497 BEACON ST 3	BOSTON	2215	ATKINS AMANDA J		495-497 BEACON ST #3	BOSTON	MA	2215
0502739000	175 BEACON ST	BOSTON	2116	BACK BAY BOSTON LLC		150 NEWPORT AVE EXTENSION	QUINCY	MA	2171
0502492000	2 W HILL PL	BOSTON	2114	BAKER JEFFREY		2 WEST HILL PL	BOSTON	MA	2114
0502389000	100 PINCKNEY ST	BOSTON	2114	BALDWIN CHRISTOPHER		100 PINCKNEY ST	BOSTON	MA	2114
2200678000	10 LINCOLN ST	BRIGHTON	2135	BAPTISTE JEAN		10 LINCOLN	BRIGHTON	MA	2135

PID FULL_ADDRESS CITY ZIPCODE OWNER ADDRESSEE MAIL_ADDRESS MAIL_CS STATE MAIL_ZIP

300-foot Abutters List - Exported from https://www.boston.gov/abutter-mailing-list-generator

0502427000	14 BRIMMER ST	BOSTON	2108	BARON JESSICA TS	C/O JESSICA BARON TS	14 BRIMMER ST	BOSTON	MA	2108
2202759000	40 SOLDIERS FIELD PL	BRIGHTON	2135	BASS GILBERT S		40 SOLDIERS FIELD PL	BRIGHTON	MA	2135
0503718000	29 BAY STATE RD	BOSTON	2215	BAY STATE CONDO 29 ASSN		29 BAY STATE RD	BOSTON	MA	2215
0503719000	31 BAY STATE RD	BOSTON	2215	BAY STATE CONDO 31 ASSN		31 BAY STATE RD	BOSTON	MA	2215
0503492000	380 BEACON ST	BOSTON	2116	BEACON COURT COOPERATIVE INC	PO BOX 130350	C/O MERIDIAN REALTY GROUP LLC	BOSTON	MA	2113
0503271000	282 BEACON ST	BOSTON	2116	BEACON EXETER APART INC	C/O MEDIATE MANAGEMENT CO	4 BUNKER HILL IND'L PARK	BOSTON	MA	2129
0502586000	142 BEACON ST	BOSTON	2116	BEACON MAINSAIL 4 LLC	C/O MAINSAIL MANAGEMENT INC	251 NEWBURY ST	BOSTON	MA	2116
0502585000	140 BEACON ST	BOSTON	2116	BEACON STREET FAMILY	C/O LEWIS A SASSON ESQ	84 STATE STREET 8TH FLOOR	BOSTON	MA	2109
0502686000	243 BEACON ST	BOSTON	2116	BELLISARIO AFARIN		243 BEACON ST	BOSTON	MA	2116
0503468000	369 BEACON ST 2	BOSTON	2116	BENDETSON VICTORIA R	C/O VICTORIA R BEDETSON	369 BEACON ST #2	BOSTON	MA	2116
0502546000	31 35 BEAVER PL	BOSTON	2108	BERLIN JAMES		7681 FISHER ISLAND DRIVE	MIAMI	FL	33109
0503503000	416 BEACON ST	BOSTON	2115	BETA NU HOUSE CORP	C/O TOM GRAY	3 SUNSET LN	HINGHAM	MA	2043
0503514000	425 BEACON ST 5	BOSTON	2115	BHARGAVA RAJEEV TS	C/O RAJEEV BHARGAVA	425 BEACON ST # 5	BOSTON	MA	2115
0502551000	88 BEACON ST 5	BOSTON	2108	BIAN BOYANG		88 BEACON ST, UNIT 5	BOSTON	MA	2108
0502463000	8 CHARLES RIVER SQ	BOSTON	2114	BIRKETT SUSAN T		8 CHARLES RIVER SQ	BOSTON	MA	2114
2200682000	16 6 CENTOLA ST	BRIGHTON	2135	BIRMINGHAM PARKWAY LJS LLC MASS LLC		58A LEO M BIRMINGHAM PKWY	BRIGHTON	MA	2135
2200687000	46 48 LEO M BIRMINGHAM	BRIGHTON	2135	BIRMINGHAM PW RLTY LLC MASS LLC		46 BIRMINGHAM PKWY	BRIGHTON	MA	2135
0502595000	168 BEACON ST 2	BOSTON	2116	BLAKELEY GERALD W	C/O GERALD W BLAKELEY III	168 BEACON ST, #2	BOSTON	MA	2116
0502530000	93 95 CHESTNUT ST	BOSTON	2108	BOGAN THOMAS R		95 CHESTNUT ST	BOSTON	MA	2108
0502526000	5 OTIS PL G	BOSTON	2108	BONNER KATHLEEN		5 OTIS PL #G	BOSTON	MA	2108
0502483000	8 W HILL PL 3	BOSTON	2114	BOOKWALTER WILLIAM		68 CHESTNUT STREET	BOSTON	MA	2108
0504068000	191 BAY STATE RD	BOSTON	2215	BOS UNIVERSITY TRST OF		191 BAY STATE RD	BOSTON	MA	2215
0503288000	322 BEACON ST PS-4	BOSTON	2116	BOSTON PARKING REALTY TRUST	C/O DANIEL B PRAWDZIK	62 ROUTE 101A	AMHERST	NH	3031
2100397000	855 859 COMMONWEALTH	BOSTON	2215	BOSTON UNIVERSITY		855 COMMONWEALTH AVE	BOSTON	MA	2215
2100358000	232 BAY STATE RD	BOSTON	2115	BOSTON UNIVERSITY TRS		232 BAY STATE RD	BOSTON	MA	2215
0503760000	92 BAY STATE RD	BOSTON	2215	BOSTON UNIVERSITY TRS OF		92 BAY STATE RD	BOSTON	MA	2215
0503758000	96 BAY STATE RD	BOSTON	2215	BOSTON UNIVERSITY TRST OF	C/O OFFICE FINANCIAL AFFAIRS	881 COMMONWEALTH AV 4TH FL	BOSTON	MA	2215
0503706000	30 BAY STATE RD	BOSTON	2215	BOSTON UNIVERSITY TRSTS		30 BAY STATE RD	BOSTON	MA	2215
0503731000	61 BAY STATE RD	BOSTON	2215	BOSTON UNIVERSITY TRSTS OF	C/O OFFICE FINANCIAL AFFAIRS	881 COMMONWEALTH AV	BOSTON	MA	2215
0504104000	212 BAY STATE RD	BOSTON	2215	BOSTON UNIVERSITY TRSTS THE		212 BAY STATE RD	BOSTON	MA	2215
0503741000	81 BAY STATE RD	BOSTON	2215	BOSTON UNIVRSTY TRSTS OF		81 BAY STATE RD	BOSTON	MA	2215
0502681000	255 BEACON ST	BOSTON	2116	BRITT EDWARD L TRST		230 BEACON	BOSTON	MA	2116
0503661000	447 BEACON ST 3	BOSTON	2115	BRUCATO CHARLES J III	C/O CHARLES J BRUCATO III	447 BEACON ST #3	BOSTON	MA	2115
0503476000	351 BEACON ST 2	BOSTON	2116	BULL DAVID E		351 BEACON ST #2	BOSTON	MA	2116
0502510000	27 BRIMMER ST 2	BOSTON	2108	BUTTERWORTH SUSAN A TS		27 BRIMMER ST # 2	BOSTON	MA	2108
0502386000	25 LIME ST 2	BOSTON	2108	CALHOUN DAVID L		25 LIME ST #2	BOSTON	MA	2108
0503646000	477 BEACON ST 6	BOSTON	2115	CAMACHO DIEGO A		254 PARK PL #3D	BROOKLYN	NY	11238
0502731000	191 BEACON ST 5	BOSTON	2116	CAMUFFO MARIALUISA		191 BACON ST #5	BOSTON	MA	2116
0503480000	336 BEACON ST 336-7	BOSTON	2116	CAPERTON DAPHNE STUART	C/O DAPHNE S CAPERTON	336 BEACON ST #336-7	BOSTON	MA	2116
0502668000	277 BEACON ST 1-B	BOSTON	2116	CAREY KENNETH D		277 BEACON ST #18	BOSTON	MA	2116
0502517000	165 MT VERNON ST 1	BOSTON	2108	CARLSON CLAIR A TS	C/O MASON & MARTIN LLP	199 WELLS AV STE 210	NEWTON	MA	2459
2202754000	1616 SOLDIERS FIELD RD	BRIGHTON	2135	CARNEY JAMES P TS	C/O BERNARDI AUTO GROUP	910 WORCESTER ST	NATICK	MA	1760
0503521000	411 BEACON ST 5	BOSTON	2115	CARROLL NOREEN	C/O NOREEN CARROLL ROGERS	8 GREGORY ST	MARBLEHEAD	MA	1945
0503317000	299 BEACON ST	BOSTON	2116	CASTRO-REICH NANCY		299 BEACON ST	BOSTON	MA	2116
0502592000	160 BEACON ST 4	BOSTON	2116	CATTUTI CARMELA		160 BEACON ST #4	BOSTON	MA	2116
0502618000	216 BEACON ST 2	BOSTON	2116	CEKIN MEHMET YAGIZ		216 BEACON ST #2	BOSTON	MA	2116
0502610000	200 202 BEACON ST 1	BOSTON	2116	CHAMPION ROBERT L		200 BEACON ST #1	BOSTON	MA	2116
0503486000	348 BEACON ST 3	BOSTON	2116	CHAN ANDREW T		348 BEACON ST #3	BOSTON	MA	2116
2200591000	14 WAVERLY ST	BRIGHTON	2135	CHAN SIMON SEW		14 WAVERLY ST	BRIGHTON	MA	2135
0502370000	152 MT VERNON ST	BOSTON	2108	CHANDLER NORTHEAST HOLDINGS LLC		77 NEWBURY ST	BOSTON	MA	2116
0503655000	459 BEACON ST	BOSTON	2115	CHARLES WHITE MANAGEMENT INC		330 COMMONWEALTH AV	BOSTON	MA	2115
0502369000	156 MT VERNON ST	BOSTON	2108	CHAYES JENNIFER T		156 MT VERNON ST	BOSTON	MA	2108
0502666000	281 BEACON ST 19	BOSTON	2116	CHENG AMY		159 HIGH RD	NEWBURY	MA	1951
PID	FULL_ADDRESS	CITY	ZIPCODE	OWNER	ADDRESSEE	MAIL_ADDRESS	MAIL_CS	STATE	MAIL_ZIP
0502532001	107 CHESTNUT ST 2	BOSTON	2108	CHESTNUT NOMINEE TRUST	C/O EUGENE H CLAPP III	10 CHARLES RIVER SQ	BOSTON	MA	2114

300-foot Abutters List - Exported from https://www.boston.gov/abutter-mailing-list-generator

0503748000	636 638 BEACON ST 402	BOSTON	2215 CHOI EUNSUK		493 SHINING ROCK DRIVE	NORTHBRIDGE	MA	1534
0502745000	163 BEACON ST B-2	BOSTON	2116 CHOO MICHELE P	C/O MICHELE P CHOO TS	40 ISABELLA ST #2E	BOSTON	MA	2116
0503466000	375 BEACON ST	BOSTON	2116 CHOW KENDRICK		375 BEACON ST	BOSTON	MA	2116
0502815000	109 BEACON ST PS-B	BOSTON	2116 CICCHETTI CLAUDE C		994 OLD RD	CONCORD	MA	1742
0501259000	ARLINGTON ST	BOSTON	2116 CITY OF BOSTON		ARLINGTON	BOSTON	MA	2116
0502605000	190 BEACON ST 4	BOSTON	2116 CIVIK THOMAS J		190 BEACON ST #4	BOSTON	MA	2116
0502367000	160 MT VERNON ST	BOSTON	2108 CLAFLIN THOMAS M II		160 MOUNT VERNON ST	BOSTON	MA	2108
0502471000	4 CHARLES RIVER SQ	BOSTON	2114 COLDREN MATTHEW F		4 CHARLES RIVER SQ	BOSTON	MA	2114
0300448010	CHARLES ST	BOSTON	2114 COMM OF MA DEPT OF HIGHWAY		CHARLES ST	BOSTON	MA	2114
0502495001	EMBANKMENT RD	BOSTON	2114 COMM OF MASS		EMBANKMENT RD	BOSTON	MA	2114
2200562001	SOLDIERS FIELD RD	ALLSTON	2134 COMM OF MASS M D C		SOLDIERS FIELD RD	ALLSTON	MA	2134
0300520000	MARTHA RD	BOSTON	2114 COMMONWEALTH OF MASS D P W		MARTHA RD	BOSTON	MA	2114
2200577000	525 WESTERN AV	BRIGHTON	2135 COMMONWEALTH OF MASSCHUSETTS		525 WESTERN AVE	ALLSTON	MA	2134
0301931000	NASHUA ST	BOSTON	2114 COMMONWLTH OF MASS		NASHUA	BOSTON	MA	2114
2200470000	CHARLES RIVER	BRIGHTON	2135 COMMONWLTH OF MASS M D C		CHARLES RIVER	ALLSTON	MA	2134
0300455000	401 CHARLES ST	BOSTON	2114 COMMWLTH OF MASS		401 CHARLES	BOSTON	MA	2114
0300448000	BLOSSOM ST	BOSTON	2114 COMMWLTH OF MASS MDC THE		BLOSSOM	BOSTON	MA	2114
0502502000	9 BRIMMER ST	BOSTON	2108 COMSTOCK HENRY W JR	C/O HENRY W COMSTOCK JR	9 BRIMMER ST	BOSTON	MA	2108
0502531000	97 CHESTNUT ST	BOSTON	2108 CONDIT SEARS B	C/O FAMILY CAPITAL TRUST CO	3 CENTENNIAL DR	PEABODY	MA	1960
0502521000	12 OTIS PL	BOSTON	2108 CONTOS ANASTASIA		12 OTIS PL	BOSTON	MA	2108
0502534000	144 CHESTNUT ST	BOSTON	2108 COOLIDGE LAWRENCE TRSTS	C/O BOAT CLUB	144 CHESTNUT ST	BOSTON	MA	2108
0502626000	234 BEACON ST 5B	BOSTON	2116 COREY DONALD J JR		234 BEACON ST, UNIT 5B	BOSTON	MA	2116
0502613000	206 BEACON ST 4	BOSTON	2116 CORINNE M HAMWEY TRUST	C/O CORRINNE M HAMWEY TS	206 BEACON ST #4	BOSTON	MA	2116
0502589000	148 BEACON ST 2	BOSTON	2116 CORMIER PAUL		148 BEACON ST #2	BOSTON	MA	2116
0502579010	128 BEACON ST J	BOSTON	2116 CORRIGAN E GERALD	C/O GERALD CORRIGAN	PO BOX 7138	GARDEN CITY	NY	11530
0503687000	482 BEACON ST 2	BOSTON	2115 COTE JANE A		482 BEACON ST, #2	BOSTON	MA	2115
0502615000	210 BEACON ST 1	BOSTON	2116 COURTNEY EUGENE J		210 BEACON ST #1	BOSTON	MA	2116
2202758000	35 SOLDIERS FIELD PL	BRIGHTON	2135 CRIMMINGS CATHERINE C TR		PO BOX 35310	BRIGHTON	MA	2135
2200104000	CAMBRIDGE ST	ALLSTON	2134 CSX TRANSPORTATION INC	CORPORATE CREATIONS NETWORK	500 WATER ST J- 910	JACKSONVILLE	FL	32202
0502741000	171 BEACON ST 3-Apr	BOSTON	2116 CUGGINO KAREN	C/O KAREN A CUGGINO	171 BEACON ST #4-3	BOSTON	MA	2116
0502698000	219 BEACON ST 1-R	BOSTON	2116 CUNNINGHAM SHANE A		219 BEACON ST #1-R	BOSTON	MA	2116
0502456000	15 CHARLES RIVER SQ	BOSTON	2114 CURTIN NEAL J		15 CHARLES RIVER SQ	BOSTON	MA	2114
0502393001	PINCKNEY ST	BOSTON	2114 CUTTERY INC MASS CORP	C/O ANGELA FARETRA	57 BEACHVIEW RD	E BOSTON	MA	2128
0503870210	4 CHARLES GATE EAST 60	BOSTON	2215 DAO MARIA CARLOTA		4 CHARLES GATE EAST #605	BOSTON	MA	2215
0502542010	7 BEAVER PL	BOSTON	2108 DAT RESIDENTIAL REALTY TRUST	C/O DAVID A TRUST TRUSTEE	220 BOYLSTON ST #1110	BOSTON	MA	2116
0502797010	303 BERKELEY ST 3-Jan	BOSTON	2116 DAVID J CANEPARI IRREVOCABLE	C/O RENEE A R EVANGELISTA	303 BERKELEY SY # 1/3	BOSTON	MA	2116
0503472000	359 BEACON ST 6	BOSTON	2116 DEARING MICHAEL E		359 BEACON ST #6	BOSTON	MA	2116
0503318000	1 EXETER ST	BOSTON	2116 DEFALCO STEPHEN P		1 EXETER ST	BOSTON	MA	2116
0502743000	167 BEACON ST 4	BOSTON	2116 DEFUSCO CHRISTINA M		167 BEACON ST #4	BOSTON	MA	2116
0502451000	21 CHARLES RIVER SQ	BOSTON	2114 DEGREGORIO BARBARA A		21 CHARLES RIVER SQ	BOSTON	MA	2114
0503701000	530 BEACON ST	BOSTON	2215 DENHARD WILLIAM G ETAL	C/O BRUCE G LUNDIE	8 AVON RD	WELLESLEY	MA	2482
0502442001	145 PINCKNEY ST 423	BOSTON	2114 DEWINTER THOMAS		145 PINCKNEY ST #421	BOSTON	MA	2114
0503278000	300 BEACON ST	BOSTON	2116 DIAMOND THELMA B	C/O JONATHAN R DIAMOND	101 MT VERNON ST #3	BOSTON	MA	2108
0502452000	20 CHARLES RIVER SQ	BOSTON	2114 DIONNE PHILIP J TS	C/O PHILIP J DIONNE	PO BOX 5	CHELMSFORD	MA	1824
0503502000	414 BEACON ST 1	BOSTON	2115 DITTRICH DYLAN R		414 BEACON ST #1	BOSTON	MA	2115
0503682000	472 BEACON ST	BOSTON	2115 DONN OC-472 BEACON ST LLC	C/O DONN OCONNELL	29 MASSACHUSETTS AV	BOSTON	MA	2115
0300445010	215 239 CHARLES ST	BOSTON	2114 DONT LOOK BACK LLC (LESSEE)	C/O LARRY KAMINSKY	4747 BETHESDA AVENUE SUITE 1100	BETHESDA	MD	20814
0502627000	236 BEACON ST 4D	BOSTON	2116 DOUGLAS DAVID W	C/O D & D DOUGLAS	302 E CORONADO RD	SANTA FE	NM	87505
0503482000	340 BEACON ST 4	BOSTON	2116 DOWER YASUKO		340 BEACON ST #4	BOSTON	MA	2116
0503458000	391 BEACON ST 1	BOSTON	2116 DOYLE KATHRYN NEAL		391 BEACON ST, UNIT 1	BOSTON	MA	2116
0502339000	52 BRIMMER ST	BOSTON	2108 DUGGAN MARK J		52 BRIMMER ST	BOSTON	MA	2108
0502606000	192 BEACON ST 1	BOSTON	2116 DUNCAN ALEXANDER ROBERT		192 BEACON ST, UNIT 1	BOSTON	MA	2116
PID	FULL_ADDRESS	CITY	ZIPCODE	OWNER	ADDRESSEE	MAIL_ADDRESS	MAIL_CS	STATE MAIL_ZIP
0502737000	179 BEACON ST 3	BOSTON	2116	DUNN JEFFREY TS	C/O JEFFREY DUNN TS	65 COMMONWEALTH AV #3A	BOSTON	MA 2116
0503881000	511 BEACON ST 13	BOSTON	2215	ECHÉ CHARLES		511 BEACON ST #13	BOSTON	MA 2215

300-foot Abutters List - Exported from https://www.boston.gov/abutter-mailing-list-generator

0502726000	285 CLARENDON ST 5	BOSTON	2116	EHR SAM FREDERICK E JR	C/O FREDERICK EHR SAM	285 CLARENDON ST #5	BOSTON	MA	2116
0503709000	11 BAY STATE RD	BOSTON	2215	ELEVEN BAY STATE RD CONDO TR		11 BAY STATE RD	BOSTON	MA	2215
0503652000	465 BEACON ST 2	BOSTON	2115	ELOVITZ DEBRA A		465 BEACON ST #2	BOSTON	MA	2115
0502590000	150 BEACON ST PH	BOSTON	2116	ENGLISH EDMOND J		150 BEACON ST - PH	BOSTON	MA	2116
0300449000	1 25 EMERSON PL	BOSTON	2114	ERP OPERATING LP	C/O EQR-R.E. TAX DERT (19100)	PO BOX A-87407	CHICAGO	IL	60680
0503304000	327 BEACON ST 3	BOSTON	2116	FACELVEGA LLC	MARTINE VOUNATSOS	463 FEDERAL CITY ROAD	PENNINGTON	NJ	8534
0503675000	456 BEACON ST 10	BOSTON	2115	FAGHRI SANAZ		456 BEACON ST #10	BOSTON	MA	2115
0503272000	286 BEACON ST 4	BOSTON	2116	FAN MATTHEW		134 WOODLAND RD	MANPTON	NH	3842
0502738000	177 BEACON ST 4	BOSTON	2116	FARBOODI MARYAM		177 BEACON ST, UNIT 4	BOSTON	MA	2116
2202753000	1650 SOLDIERS FIELD RD	BRIGHTON	2135	FCA REALTY LLC		1000 CHRYSLER DR CIMS 485-03-20	AUBURN HILLS	MI	48326
0502704001	278 CLARENDON ST 9	BOSTON	2116	FEDAK MICHAEL TS		278 CLARENDON ST #9	BOSTON	MA	2116
0502596000	170 BEACON ST	BOSTON	2116	FEDERAL REPUBLIC OF GERMANY		170 BEACON	BOSTON	MA	2116
2202761000	1500 SOLDIERS FIELD RD	BRIGHTON	2135	FIFTEEN HUNDERED SOLDIERS	C/O M N GONDELMAN-HIGH TEK	1500 SOLDIERS FIELD RD EXT	BRIGHTON	MA	2135
0502814000	111 BEACON ST	BOSTON	2116	FISHER COLLEGE	C/O ACCOUNTS PAYABLE	118 BEACON ST	BOSTON	MA	2116
0502568000	104 BEACON ST	BOSTON	2116	FISHER JUNIOR COLLEGE		104 BEACON	BOSTON	MA	2116
0502572000	114 BEACON ST	BOSTON	2116	FISHER SCHOOL THE		114 BEACON	BOSTON	MA	2116
0503694000	506 BEACON ST	BOSTON	2215	FIVE 06 BEACON LLC	BLACKSTONE WILLIAMS PROPERTI	302 NEWBURY STREET	BOSTON	MA	2115
0503875000	523 BEACON ST	BOSTON	2215	FIVE-23 BEACON LLC	C/O INVESTMENT PROP LTD	825 BEACON ST	NEWTON	MA	2459
0503914000	585 BEACON ST B	BOSTON	2215	FIVE85 BEACON STREET LLC MASS LLC	C/O URI TASCH	P O BOX 21497	BALTIMORE	MD	21282
0502523000	8 OTIS PL	BOSTON	2108	FLAHERTY TRACEY E TS	C/O TRACEY E FLAHERTY	8 OTIS PL	BOSTON	MA	2108
0503519000	415 BEACON ST	BOSTON	2115	FOUR 15 BEACON STREET		415 BEACON ST	BOSTON	MA	2115
2200569001	441 443 WESTERN AV	BRIGHTON	2135	FOUR 41 LLC MASS LLC	C/O 441 LLC	5 WASHINGTON ST # D6	READING	MA	1867
0503662000	445 BEACON ST	BOSTON	2115	FOUR 45 BEACON ST CONDO TR		445 BEACON	BOSTON	MA	2115
0503660000	449 BEACON ST	BOSTON	2115	FOUR 49 BEACON ST CONDO TR		449 BEACON ST	BOSTON	MA	2115
0503676000	458 BEACON ST	BOSTON	2115	FOUR 58 BEACON CONDO ASSN		458 BEACON	BOSTON	MA	2115
0503672000	450 BEACON ST	BOSTON	2115	FOUR FIFTY BEACON ST INC	C/O RONALD KUPPERSMITH	7 CHESSMAN DR	SHARON	MA	2067
0503654000	461 BEACON ST	BOSTON	2115	FOUR SIXTY ONE BEACON ST CONDO ASSN		461 BEACON	BOSTON	MA	2115
0502734000	185 BEACON ST	BOSTON	2116	FRANKLIN CAPITAL PARTNERS CO	C/O CABOT AND COMPANY	213 NEWBURY ST	BOSTON	MA	2116
2200588000	16 WAVERLY ST	BRIGHTON	2135	FRIAR AARON W		16 WAVERLY ST	BRIGHTON	MA	2135
0502744000	165 BEACON ST 2	BOSTON	2116	FRIEDMAN JOEL		165 BEACON ST #2	BOSTON	MA	2116
0502591000	154 BEACON ST 1	BOSTON	2116	GACCIONE PETER		PO BOX 979	EAST DENNIS	MA	2641
2200590000	14 WAVERLY ST	BRIGHTON	2135	GALVIN THOMAS J	14R WAVERLY ST	C/O THOMAS J GALVIN	BRIGHTON	MA	2135
0502395000	96 98 CHARLES ST	BOSTON	2114	GANICK JOHN	C/O CRESCENT REALTY CO	85 CHARLES ST	BOSTON	MA	2114
0502515000	37 BRIMMER ST 1	BOSTON	2114	GAO HAI		37 BRIMMER ST #1	BOSTON	MA	2114
0300370000	255 265 CHARLES ST	BOSTON	2114	GENERAL HOSPITAL CORP	ATTN: PARTNERS HEALTHCARE/REA	PO BOX 6240	BOSTON	MA	2114
0502423000	22 BRIMMER ST	BOSTON	2108	GEORGANTAS PETER E	C/O PETER GEORGANTIS TRUSTEE	22 BRIMMER ST	BOSTON	MA	2108
0502693000	229 BEACON ST 3	BOSTON	2116	GEORGE AND CATHLEEN DOONAN	CATHLEEN M DOONAN	124 WINDY ROW	PETERBOROUGH	NH	3458
0502802000	137 BEACON ST	BOSTON	2116	GIBSON SOCIETY INC		137 BEACON ST	BOSTON	MA	2116
0503703000	534 BEACON ST PS 4	BOSTON	2215	GIULIANO FAMILY TRUST		534 BEACON ST, UNIT 606	BOSTON	MA	2215
0502387000	31 LIME ST	BOSTON	2108	GLEESON RICHARD W		31 LIME ST	BOSTON	MA	2108
0502746000	161 BEACON ST	BOSTON	2116	GLYNN PASCAL	C/O FAIRFIELD REALTY	83 CENTRAL ST 2ND FLOOR	BOSTON	MA	2109
0503312000	309 BEACON ST	BOSTON	2116	GLYNN REALTY ASSO III LLC	C/O GLYNN RLTY ASSOC LLC	83 CENTRAL ST	BOSTON	MA	2109
0503470000	363 BEACON ST 2	BOSTON	2116	GLYNN REALTY ASSOC I LLC		83 CENTRAL ST #	BOSTON	MA	2109
0502488000	W HILL PL	BOSTON	2114	GOLDIE KENNETH S		6 WEST HILL PLACE	BOSTON	MA	2114
0502432000	4 BRIMMER ST	BOSTON	2108	GPD BRIMMER 4 LLC MASS LLC		PO BOX 420	BROOKLINE	MA	2446
0503644000	481 BEACON ST 481-34	BOSTON	2115	GRAHAM PHILIP J		479 BEACON ST #34	BOSTON	MA	2115
0502461000	9 CHARLES RIVER SQ	BOSTON	2114	GREELEY MICHAEL A		9 CHARLES RIVER SQ	BOSTON	MA	2114
0503688000	484 BEACON ST 4	BOSTON	2115	GREENBERG MICHAEL		488 BEACON ST, UNIT 10/11	BOSTON	MA	2115
0503886000	501 BEACON ST 3	BOSTON	2215	GUIRGUIS MAGGY LOUIS WISSA	C/O MAGGY LOUIS W GUIRGUIS	12 PINWOOD HILLS	LONGMEADOW	MA	1106
0502337000	56 BRIMMER ST	BOSTON	2108	HABERMANN RICHARD C		56 BRIMMER ST	BOSTON	MA	2108
0503690000	486 BEACON ST 5	BOSTON	2115	HAN LU		511 BUTTONWOOD DR	DOWNINGTOWN	PA	19335
PID	FULL_ADDRESS	CITY	ZIPCODE	OWNER	ADDRESSEE	MAIL_ADDRESS	MAIL_CS	STATE	MAIL_ZIP
0502555000	2 BEAVER ST	BOSTON	2108	HARRIS ROBERT P		2 BEAVER ST	BOSTON	MA	2108
0502554000	91 BEACON ST 1	BOSTON	2108	HARTWELL JOHN R		91 BEACON ST #1	BOSTON	MA	2108
2200480000	610 640 SOLDIERS FIELD	BRIGHTON	2135	HARVARD COLLEGE		610 SOLDIERS FIELD RD	ALLSTON	MA	2163

300-foot Abutters List - Exported from https://www.boston.gov/abutter-mailing-list-generator

2200579000	1360 1350 SOLDIERS FIEL	BRIGHTON	2135 HARVARD RE/ ALLSTON INC	C/O HARVARD REAL ESTATE SERVIC	1350 MASSACHUSETTS AVE #912	CAMBRIDGE	MA	2138	
2200554000	285 291 WESTERN AV	ALLSTON	2134 HARVARD RE/ALLSTON INC	C/O HARVARD REAL ESTATE SERVIC	1350 MASSACHUSETTS AVE	CAMBRIDGE	MA	2138	
2200567000	415 WESTERN AV	BRIGHTON	2135 HARVARD REAL ESTATE	C/O HARVARD REAL ESTATE ALLSTC	1350 MASSACHUSETTS AV STE 980	CAMBRIDGE	MA	2138	
2200570000	445 WESTERN AV	BRIGHTON	2135 HARVARD REAL ESTATE-ALLSTON INC	C/O HARVARD REAL ESTATE-ALLSTC	1350 MASSACHUSETTS AV	CAMBRIDGE	MA	2138	
2100396010	SOLDIERS FIELD RD	ALLSTON	2134 HARVARD UNIVERSITY BEACON	C/O HARVARD R EST SERVICES	1350 MASS AV-HOLYOKE CTR #912	CAMBRIDGE	MA	2138	
0502457000	14 CHARLES RIVER SQ	BOSTON	2114 HASELWANDTER STEFAN		14 CHARLES RIVER SQ	BOSTON	MA	2114	
0502425000	18 BRIMMER ST	BOSTON	2108 HASSAN RESIDENTIAL	C/O HASSAN RESIDENTIAL PROPER	218 NEWBURY ST #3	BOSTON	MA	2116	
2200101001	52 CAMBRIDGE ST	ALLSTON	2134 HAWKEYE LIMITED PARTNERSHIP		52 CAMBRIDGE ST	ALLSTON	MA	2134	
0502672000	269 BEACON ST 2	BOSTON	2116 HAYES JOHN J 3RD TRST	C/O JOHN J HAYES III	920 SE ATLANTIC DRIVE	LANTANA	FL	33462	
0502601000	182 BEACON ST 6 WCOR	BOSTON	2116 HERRING DAVID E		3180 MATHIESON DR NE #1101	ATLANTA	GA	30305	
0502633000	250 BEACON ST 7	BOSTON	2116 HICKS WILLIAM F M ETAL		250 BEACON ST #7	BOSTON	MA	2116	
0502437000	116 CHARLES ST 5	BOSTON	2114 HIGGINBOTHAM RICHARD A TS	C/O RICHARD A HIGGINBOTHAM	315 SOUTH LAKE DR #1-B	PALM BEACH	FL	33480	
0502513000	33 BRIMMER ST A	BOSTON	2108 HILLS GEOFFREY O	C/O GEOFFREY HILLS	214 WIANNO CI	OSTERVILLE	MA	2655	
0503287000	320 BEACON ST 1	BOSTON	2116 HODGETTS LIVING TRUST		320 BEACON ST, UNIT 1	BOSTON	MA	2116	
0502817000	105 BEACON ST 10	BOSTON	2116 HOFFMAN MICHAEL J		105 BEACON ST, UNIT 10	BOSTON	MA	2116	
0502390000	98 PINCKNEY ST	BOSTON	2114 HUGHES FRANCIS J JR		98 PINCKNEY	BOSTON	MA	2114	
0503294000	347 BEACON ST	BOSTON	2116 HUMAN ENGINEERING LAB		347 BEACON	BOSTON	MA	2116	
0503494000	396 BEACON ST 6	BOSTON	2116 IGLESIAS OTTO H	C/O OTTO IGLESIAS	396 BEACON ST #6	BOSTON	MA	2116	
0503744000	97 BAY STATE RD	BOSTON	2215 INCORPORATE ALUMNI	C/O STAN WULF	902 SALEM END RD	FRAMINGHAM	MA	1702	
2202762002	83 LEO M BIRMINGHAM PV	BRIGHTON	2135 INFINITY BROADCASTING	CORPORAT	2400 MARKET ST 4TH FLOOR	ENTERCOM OPERATIONS, INC.	PHILADELPHIA	MA	19013
0503713000	19 BAY STATE RD PS-4	BOSTON	2215 JAENISCH RUDOLF		RUDOLF JAENISCH/ WHITEHEAD INS	9 CAMBRIDGE CENTER	CAMBRIDGE	MA	2142
2200586000	15 17 MACKIN ST	BRIGHTON	2135 JAIN ANIMESH		17 15 MACKIN ST	BRIGHTON	MA	2135	
0503469000	367 BEACON ST	BOSTON	2116 JAMAL RIZWAN M		367 BEACON ST	BOSTON	MA	2116	
0502446000	140 CHARLES ST 140-2	BOSTON	2114 JBZ LLC		872 MASSACHUSETTS AV STE 1-2	CAMBRIDGE	MA	2139	
0503522000	409 BEACON ST PH	BOSTON	2115 JENNIFER V DORAN 2020 REVOCABLE TRUST		409 BEACON ST, UNIT PH	BOSTON	MA	2115	
2202750000	1800 SOLDIERS FIELD RD	BRIGHTON	2135 JHM RIVER LLC MASS LLC		440 BEDFORD ST	LEXINGTON	MA	2420	
0503714000	23 BAY STATE RD 8	BOSTON	2215 JOANNE MEIROVITZ TS		23 BAY STATE RD #8	BOSTON	MA	2215	
0502533000	109 CHESTNUT ST 4	BOSTON	2108 JOHN CHRISTIAN HESSLER TRUST	C/O JOHN HESSLER	PO BOX 10485	JACKSON	WY	83001	
0502476000	CHARLES RIVER SQ	BOSTON	2114 JOHNSON EDWARD C 111 ETAL	C/O MELANIE SOMMER	11 KEEWAYDIN DR STE 100	SALEM	NH	30379	
0503671000	448 BEACON ST PS-3	BOSTON	2115 JOHNSON JOHN		448 BEACON ST #8	BOSTON	MA	2115	
0502522000	10 OTIS PL 3-B	BOSTON	2108 JORDAN VERONICA G		10 OTIS PL #3A	BOSTON	MA	2108	
0502495000	20 EMBANKMENT RD	BOSTON	2114 JOSEPH FREDERICK		20 EMBANKMENT RD	BOSTON	MA	2114	
2200572000	495 WESTERN AV	BRIGHTON	2135 JOSEPH M SMITH COMMUNITY	C/O JOSEPH M SMITH COMMUNITY F	287 WESTERN AV	ALLSTON	MA	2134	
0502687000	241 BEACON ST	BOSTON	2116 JULIA WARD HOWE CONDO TRUST		241 BEACON ST	BOSTON	MA	2116	
0503498000	406 BEACON ST	BOSTON	2115 KAPETANAKIS MARILYN M TS		252 WINTROP ST	MEDFORD	MA	2155	
0503707000	60 CHARLES GATE WEST 4	BOSTON	2215 KASDON MURIEL C TS	C/O CHARLES GATE PROPERTY MAN	867 BOYLSTON ST 3RD FL	BOSTON	MA	2116	
0503513000	427 BEACON ST	BOSTON	2115 KATZ GEORGE		427 BEACON ST	BOSTON	MA	2115	
0502816000	107 BEACON ST	BOSTON	2116 KEATING DORIS J	C/O STREET & COMPANY	78 CHARLES ST	BOSTON	MA	2114	
0503296000	341 BEACON ST 4C	BOSTON	2116 KEATING MARK R		341 BEACON ST #4C	BOSTON	MA	2116	
0502391000	96 PINCKNEY ST	BOSTON	2114 KEMPAINEN HILARY SEWARD		96 PINCKNEY ST	BOSTON	MA	2114	
2200566000	395 WESTERN AV	BRIGHTON	2135 KENNEY GREG A TS	C/O HARVARD REAL ESTATE SERV	1350 MASSACHUSETTS AV #1027	CAMBRIDGE	MA	2138	
0502810000	119 BEACON ST 5	BOSTON	2116 KEYES COLLEEN M		119 BEACON ST # 5	BOSTON	MA	2116	
2203427000	33 NEWTON ST	BRIGHTON	2135 KILGALLEN MARY		33 NEWTON ST	BRIGHTON	MA	2135	
0502729000	195 BEACON ST 6	BOSTON	2116 KIM RHAN KATHLEEN		195 BEACON ST UNIT 6	BOSTON	MA	2116	
0502501000	7 BRIMMER ST	BOSTON	2108 KLEIN ERNEST V		7 BRIMMER ST	BOSTON	MA	2108	
0502598000	180 BEACON ST 9D	BOSTON	2116 KOHN SUSAN G		180 BEACON ST #9D	BOSTON	MA	2116	
0503680000	468 BEACON ST	BOSTON	2115 KOHN TOMAS O		468 BEACON	BOSTON	MA	2115	
0502429000	10 BRIMMER ST	BOSTON	2108 KORB DONALD R		10 BRIMMER	BOSTON	MA	2108	
0502335000	87 CHESTNUT ST	BOSTON	2108 KUMIN ELIZABETH		87 CHESTNUT ST	BOSTON	MA	2108	
0502747000	159 BEACON ST	BOSTON	2116 KWONG CHEE W TS	C/O CHEE W KWONG	159 BEACON ST	BOSTON	MA	2116	
	PID FULL_ADDRESS CITY ZIPCODE		OWNER	ADDRESSEE	MAIL_ADDRESS	MAIL_CS	STATE	MAIL_ZIP	
0502740000	173 BEACON ST	BOSTON	2116 LA RESIDENCE CONDO TR		173 BEACON	BOSTON	MA	2116	
0503745000	99 BAY STATE RD	BOSTON	2215 LAMBDA ZETA ASSOCTS INC	C/O JAMES A MONK	87-3599 MAMALAHOA HWY	CAPTAIN COOK	HI	96704	
0502697000	221 BEACON ST 2	BOSTON	2116 LAMURAGLIA GLENN M		221 BEACON ST #2	BOSTON	MA	2116	
0502808000	125 BEACON ST 13	BOSTON	2116 LANE DAVID M	C/O DAVID LANE	125 BEACON ST #13	BOSTON	MA	2116	

300-foot Abutters List - Exported from <https://www.boston.gov/abutter-mailing-list-generator>

0502664000	283 BEACON ST 283	BOSTON	2116 LAPLACA DAMIAN R		283 BEACON ST #283	BOSTON	MA	2116
0503459000	389 BEACON ST 6	BOSTON	2116 LAU SIU FU GODFREY		389 BEACON ST #6	BOSTON	MA	2116
0502736000	181 BEACON ST 5	BOSTON	2116 LAWLESS JAMES TS		264 NEWBURY STREET	BOSTON	MA	2116
0503679000	464 BEACON ST 4F	BOSTON	2115 LDJ DEVELOPMENT LLC	C/O LDJ DEVELOPMENT LLC	190 HIGH ST 6TH FL	BOSTON	MA	2110
0503911000	591 BEACON ST 4	BOSTON	2215 LEE DANIEL YENHONG		591 BEACON ST #4	BOSTON	MA	2215
0501970000	W CEDAR ST	BOSTON	2114 LEE DAVID Y TS	C/O DAVID LEE	98 W CEDAR ST	BOSTON	MA	2114
0502535000	142 CHESTNUT ST 3	BOSTON	2108 LEE HENRY	C/O J EWING, ROPES & GRAY LLP	800 BOYLSTON ST	BOSTON	MA	2199
0502509000	25 BRIMMER ST 2	BOSTON	2108 LEE THEODORE ALLEN	C/O THEODORE A LEE	25 BRIMMER ST #2	BOSTON	MA	2108
0502608000	196 BEACON ST 2	BOSTON	2116 LEERINK HANS H TS		196 BEACON ST #2	BOSTON	MA	2116
0502559000	94 BEACON ST 2	BOSTON	2108 LEIGHTON ILANA H		94 BEACON ST #2	BOSTON	MA	2108
2200685000	LEO M BIRMINGHAM PW	BRIGHTON	2135 LEO BIRMINGHAM DEVELOPMENT LLC		320 WASHINGTON ST, UNIT SUITE 3FF	BROOKLINE	MA	2445
0503289000	324 332 BEACON ST 146	BOSTON	2116 LESBURG SUSAN TS	C/O MICHAEL C LESBURG	12 HANCOCK STREET	BOSTON	MA	2114
0503673000	452 BEACON ST 7	BOSTON	2115 LESPERANCE RUTH L		452 BEACON ST #7	BOSTON	MA	2115
0502448000	141 REVERE ST	BOSTON	2114 LEWIS M LEONARD		141 REVERE ST	BOSTON	MA	2114
0502677000	259 BEACON ST 3	BOSTON	2116 LI XIAOJING		202 CHARLES ST	CAMBRIDGE	MA	2141
0503720000	33 BAY STATE RD 2	BOSTON	2215 LIN ALICE LISING		33 BAY STATE RD UNIT 2	BOSTON	MA	2215
0502641000	280 BEACON ST 32	BOSTON	2116 LINDA MARIE PETERS 2011 TRUST	C/O LINDA PETERS-GREENWOOD	280 BEACON ST #32	BOSTON	MA	2116
0502806000	129 BEACON ST 4	BOSTON	2116 LISS AVI		198 TREMONT ST., #440	BOSTON	MA	2116
2200592000	12 WAVERLY ST	BRIGHTON	2135 LIU LEI	C/O JINCHEN YANG	60 ENDICOTT ST	WESTWOOD	MA	2090
2200589000	16 R WAVERLY ST	BRIGHTON	2135 LIU TONG		16 R WAVERLY ST	BRIGHTON	MA	2135
2202747000	372 N BEACON ST	BRIGHTON	2135 LMC CICCULO REALTY LLC		75 N BEACON ST	BOSTON	MA	2134
0503656000	457 BEACON ST 5	BOSTON	2115 MACCHIA NANCY		457 BEACON ST #5	BOSTON	MA	2115
0503692000	492 BEACON ST 15	BOSTON	2115 MAG PROPERTIES LLC		5603 CROSS GATE DRIVE NW	ATLANTA	GA	30327
0501972000	96 B96 W CEDAR ST	BOSTON	2114 MAGUIRE ROBERT G		96 W CEDAR	BOSTON	MA	2114
0502660000	293 BEACON ST PS-B	BOSTON	2116 MAHALO REALTY TRUST	C/O RICE /HEARD & BIGELOW INC	50 CONGRESS ST SUITE #900	BOSTON	MA	2109
0502811000	117 BEACON ST 1	BOSTON	2116 MAK BRAD JASON		117 BEACON ST #1	BOSTON	MA	2116
0502450000	22 CHARLES RIVER SQ	BOSTON	2114 MALONEY EDWARD M		22 CHARLES RIVER SQ	BOSTON	MA	2114
0503779000	52 BAY STATE RD	BOSTON	2215 MARINO PAUL M		52 BAY STATE RD	BOSTON	MA	2215
0502750010	151 153 BEACON ST	BOSTON	2116 MARRANO MARK C TRUSTEE		151153 BEACON ST	BOSTON	MA	2116
0502631000	244 BEACON ST 244-1C	BOSTON	2116 MARTIN ELLEN M	C/O ELLEN MARTIN	19 BERKLEY DR	LOCKPORT	NY	14094
0502607000	194 BEACON ST 1	BOSTON	2116 MARTIN JOHN	C/O STEAMBOAT REALTY LLC/ JAME	92 STATE ST	BOSTON	MA	2109
0502342000	36 LIME ST	BOSTON	2108 MASHIKIAN PAUL		36 LIME ST	BOSTON	MA	2108
0503879000	515 BEACON ST	BOSTON	2215 MASS DELTA ALUMNI CORP	C/O FSILG COOPERATIVE	PO BOX 397068	CAMBRIDGE	MA	2139
0300381001	243 245 CHARLES ST	BOSTON	2114 MASS GEN EYE * EAR INF		243 CHARLES	BOSTON	MA	2114
2100396000	COMMONWEALTH AV	ALLSTON	2134 MASS TURNPIKE AUTH CL62		COMMONWEALTH AVE	BOSTON	MA	2215
2201906100	LINCOLN ST	BRIGHTON	2135 MASS TURNPIKE AUTHORITY		LINCOLN ST	BRIGHTON	MA	2135
2202770000	PARSONS ST	BRIGHTON	2135 MASSACHUSETTS TURNPIKE AUTH		PARSONS	BRIGHTON	MA	2135
0502560000	95 BEACON ST 6	BOSTON	2108 MAYLEE CLIFFORD TRUST		95 BEACON ST #6	BOSTON	MA	2108
0502449000	23 CHARLES RIVER SQ	BOSTON	2114 MCCARTY PAULETTE A		23 CHARLES RIVER SQ	BOSTON	MA	2114
0502566000	100 BEACON ST PHB	BOSTON	2116 MCCOY JACQUELINE R	C/O WILLIAM HELMAN	106 7TH AVE, UNIT 12 (PH)	NEW YORK	NY	10011
0502674000	265 BEACON ST B	BOSTON	2116 MCDERMOTT ANTHONY P		265 BEACON ST, UNIT B	BOSTON	MA	2116
2202751000	1750 SOLDIERS FIELD RD	BRIGHTON	2135 MCDONALDS REAL ESTATE COMPANY	C/O MCDONALDS REAL ESTATE CO	110 N CARPENTER ST	CHICAGO	IL	60607
0502008000	145 CHARLES ST 3	BOSTON	2114 MCGUIRE MICHAELA		145 CHARLES ST #3	BOSTON	MA	2114
0503281000	306 BEACON ST 3	BOSTON	2116 MEGHAN C KELLEY FAMILY TRUST		306 BEACON ST, UNIT 3	BOSTON	MA	2116
0502499000	112 PINCKNEY ST 34	BOSTON	2114 MERTENS RICHARD B	C/O RICHARD B MERTENS	290 KINGSTON WAY APT 281	DUXBURY	MA	2332
0502543010	15 25 BEAVER PL	BOSTON	2108 MEWS ON BEAVER PLACE		15-25 BEAVER PLACE	BOSTON	MA	2108
0502544001	27 29 BEAVER PL	BOSTON	2108 MICALI LISA K TS	C/O LISA & JIM MICALI	27 BEAVER PLACE	BOSTON	MA	2108
0503698000	520 BEACON ST 3B	BOSTON	2215 MICLEY BRUCE H		895 COMMONWEALTH AV	NEWTON	MA	2459
0503314000	305 BEACON ST	BOSTON	2116 MITCHELL 305 BEACON ST LLC	C/O CHRIS MITCHELL	61 CONCOLOR AVE	NEWTON	MA	2458
0502690000	235 BEACON ST 3	BOSTON	2116 MIZZI COLLEEN R	C/O COLEEN R MIZZI	374 MARLBOROUGH ST	BOSTON	MA	2115
0502524000	7 OTIS PL 2	BOSTON	2108 MONTAG J LEE		7 OTIS PL #2	BOSTON	MA	2108
0502576000	122 BEACON ST 6	BOSTON	2116 MORGAN LINDA S TS		122 BEACON ST #6	BOSTON	MA	2116
0503708000	9 BAY STATE RD	BOSTON	2215 MORWAY JOHN B TS		9 BAY STATE RD	BOSTON	MA	2215
0502624000	230 BEACON ST B6	BOSTON	2116 MOSHER DANA R		230 BEACON STREET UNIT B-6	BOSTON	MA	2116
0502678000	330 DARTMOUTH ST 4N	BOSTON	2116 MSC DARTMOUTH STREET TRUST	C/O BETTE RILEY	PO BOX 892	HOLLIS	NH	3049

300-foot Abutters List - Exported from <https://www.boston.gov/abutter-mailing-list-generator>

0504050000	155 BAY STATE RD	BOSTON	2215 MUTAW CORP THE	C/O MUTAW CORPORATION	8815 WESLEYAN RD	INDIANAPOLIS	IN	46268
2200583000	WESTERN AV	BRIGHTON	2135 MVC WESTERN AVE REALTY LLC	C/O THE MOUNT VERNON COMPANY	1200 SOLDIERS FIELD RD STE 102	BOSTON	MA	2134
0502430000	8 BRIMMER ST 1-B	BOSTON	2108 NASSAR JAMES J JR TS		26 HUNTERS RUN PL	HAVERHILL	MA	1832
0503508000	426 BEACON ST	BOSTON	2115 NEW ENGLAND COLLEGE		426 BEACON	BOSTON	MA	2115
2200599000	15 RICHARDSON ST	BRIGHTON	2135 NG PAK-YI		15 RICHARDSON ST	BRIGHTON	MA	2135
0503723000	39 BAY STATE RD	BOSTON	2215 NO MESTAYKH LLC MASS LLC	C/O BAY MANAGEMENT CORP	990 WASHINGTON ST #302	DEDHAM	MA	2026
0503647000	475 BEACON ST 8	BOSTON	2115 NORTHWELL INC MASS CORP		4200 TOLEDO ST	CORAL GABLES	FL	33146
0502480000	10 W HILL PL	BOSTON	2114 NOVAK G. MICHAEL	C/O G MICHEL NOVAK	10 WEST HILL PL	BOSTON	MA	2114
0502818000	103 BEACON ST	BOSTON	2116 ONE 03 BEACON ST CONDOMINIUM		103 BEACON	BOSTON	MA	2116
0502440000	108 CHARLES ST	BOSTON	2114 ONE 06-108 CHARLES ST CD TR		108 CHARLES ST	BOSTON	MA	2114
0502436000	118 CHARLES ST	BOSTON	2114 ONE 18 CHARLES ST REALTY LLC MASS	C/O TUCK LEONG	118 CHARLES ST #1	BOSTON	MA	2114
0502007000	141 143 CHARLES ST	BOSTON	2114 ONE 41-143 CHARLES STREET		141 CHARLES	BOSTON	MA	2114
0502588000	146 BEACON ST	BOSTON	2116 ONE 46 BEACON CONDO ASSN		146 BEACON	BOSTON	MA	2116
0502749000	155 BEACON ST	BOSTON	2116 ONE 55 BEACON ST CONDO TR		155 BEACON	BOSTON	MA	2116
0502012000	155 159 CHARLES ST	BOSTON	2114 ONE FIFTY ONE-153 CHARLES	C/O CVS / CAPEMARK #260	ONE CVS DRIVE ATTN: ACCOUNTING	WOONSOCKET	RI	2895
2201906075	100 LEO M BIRMINGHAM P	BRIGHTON	2135 ONE HUNDRED LEO BIRMINGHAM	C/O ONE HUNDRED LEO	100 LEO M BIRMINGHAM PKWY	BRIGHTON	MA	2135
0502532000	101 CHESTNUT ST	BOSTON	2108 ONE HUNDRED ONE CHESTNUT	PREMIER PROPERTY SOLUTIONS	311 SUMMER ST SUITE #200	BOSTON	MA	2210
0502819000	101 BEACON ST	BOSTON	2116 ONE-O-ONE BEACON LLC		421 HANOVER ST	BOSTON	MA	2113
0502671000	271 BEACON ST 5	BOSTON	2116 ORR JENNIFER L		271 BEACON ST #5	BOSTON	MA	2116
0502489000	5 W HILL PL C	BOSTON	2114 OWENS WILLIAM W JR		5 WEST HILL PL #C	BOSTON	MA	2114
0503274000	292 BEACON ST 1	BOSTON	2116 PALMISCIANO DOROTHY J	C/O ABACUS	PO BOX 400	PORT ST JOE	FL	32457
2200650000	26 WAVERLY ST 405	BRIGHTON	2135 PANG JIAN		26 WAVERLY ST #405	BRIGHTON	MA	2135
0502503000	11 BRIMMER ST	BOSTON	2108 PANGARO GERALDINE F		11 BRIMMER ST	BOSTON	MA	2108
0503686000	480 BEACON ST 1	BOSTON	2115 PAPPO CARL		480 BEACON ST, UNIT 1	BOSTON	MA	2115
0502418000	135 MT VERNON ST	BOSTON	2108 PARISH OF THE ADVENT		135 MOUNT VERNON	BOSTON	MA	2108
0502419000	30 BRIMMER ST	BOSTON	2108 PARISH OF THE ADVENT CHURCH		30 BRIMMER	BOSTON	MA	2108
0502541000	122 118 CHESTNUT ST	BOSTON	2108 PARK STREET KIDS INC		ONE PARK ST	BOSTON	MA	2108
0502670000	273 BEACON ST 2	BOSTON	2116 PEDERSEN SHAUN F		273 BEACON ST # 2	BOSTON	MA	2116
0502609000	198 BEACON ST	BOSTON	2116 PERRONCELLO-GRIFFEL LISA	C/O LISA GRIFFEL-PERRONCELLO	198 BEACON ST	BOSTON	MA	2116
0503471000	361 BEACON ST PS-C	BOSTON	2116 PETERSON BRADLEY		361 BEACON ST, UNIT 2	BOSTON	MA	2116
0502577000	124 BEACON ST 1F	BOSTON	2116 PHAM THANH H		124 BEACON ST, UNIT 1F	BOSTON	MA	2116
0502508000	23 BRIMMER ST 2	BOSTON	2108 PIERCE RICHARD T		23 BRIMMER ST #2	BOSTON	MA	2108
0502514000	35 BRIMMER ST	BOSTON	2108 PIERCE ROBERT W JR TS		35 BRIMMER ST	BOSTON	MA	2108
0502659000	295 297 BEACON ST 62	BOSTON	2116 PIRE MICHAEL J		295 BEACON ST #62	BOSTON	MA	2116
2200603000	32 30 RICHARDSON ST	BRIGHTON	2135 PIRES AMARO L		30 RICHARDSON ST	BRIGHTON	MA	2135
0503313000	307 BEACON ST 2	BOSTON	2116 PIZZUTI DONATO F	C/O RUSSELL L PETERSON	1125 COMMONWEALTH AV	ALLSTON	MA	2134
0502547000	37 41 BEAVER PL BP-2	BOSTON	2108 POLARIS 2000 LLC		PO BOX 1620	NORTH HAMPTON	NH	3862
0502553000	90 BEACON ST 1	BOSTON	2108 POPPLER MEREDITH		31 EDWARD DR	WINCHESTER	MA	1890
2200577010	1345 SOLDIERS FIELD RD	BRIGHTON	2135 PRESIDENT & FELLOWS OF	PRESIDENT & FELLOWS OF HARVAR	1350 MASSACHUSETTS AV #980	CAMBRIDGE	MA	2138
0503489000	354 BEACON ST 9	BOSTON	2116 PROJECT 23 BEACON LLC		701 CASTANO AVENUE	SAN ANTONIO	TX	78209
2202762000	1480 SOLDIERS FIELD RD	BRIGHTON	2135 QILU BOSTON LLC		1480 SOLDIERS FIELD RD	BRIGHTON	MA	2135
0503716000	25 BAY STATE RD 6	BOSTON	2115 RAN YULING		25 BAY STATE RD #6	BOSTON	MA	2115
0501973000	94 W CEDAR ST	BOSTON	2114 RAO PASQUALE V	C/O EMPIRE REALTY	PO BOX 540070	WALTHAM	MA	2451
0502005000	137 CHARLES ST 3	BOSTON	2114 RAO WILLIAM M TS	C/O WILLIAM M RAO TS	326 PROSPECT HILL ROAD	WALTHAM	MA	2451
0502481000	9 W HILL PL	BOSTON	2114 RAUSEO MICHAEL J		9 WEST HILL PLACE	BOSTON	MA	2114
0502477000	32 EMBANKMENT RD	BOSTON	2114 RAUSEO MICHAEL J III		32 EMBANKMENT RD	BOSTON	MA	2114
2203428000	145 NEWTON ST	BRIGHTON	2135 RED LINE LIMIT LLC	221 NORTH BEACON ST	C/O NB DEVELOPMENT GROUP LLC	BRIGHTON	MA	2135
0502561000	96 BEACON ST 3	BOSTON	2108 REED CYNTHIA	C/O CYNTHIA REED TS	PO BOX 1390	NEW YORK	NY	10150
2202760000	1550 SOLDIERS FIELD RD	BRIGHTON	2135 RESIDENCES AT 1550 SOLDIERS FIELD R	100 GALEN ST	100 C/O SMC MANAGEMENT CORP, UNIT	WATERTOWN	MA	2472
2202757000	21 SOLDIERS FIELD PL	BRIGHTON	2135 RESIDENCES AT SOLDIER FIELD ROAD	CONDOMINIUM LIMITED PARTNERSHIP	100 GALEN STREET	WATERTOWN	MA	2472
0502519000	2 OTIS PL 5	BOSTON	2108 RETALS LLC	PARK PROPERTY MGT GROUP LLC	1963 COMMONWEALTH AV SUITE #1	BRIGHTON	MA	2135
0503889000	491 493 BEACON ST	BOSTON	2215 RICUPERO DAVID G		128 E EMERSON ST	MELROSE	MA	2176
0502673000	267 BEACON ST 1	BOSTON	2116 RIOS MANUEL Z		267 BEACON ST #1	BOSTON	MA	2116
0502581010	132 134 BEACON ST	BOSTON	2116 RIVERSIDE CONDO TRUST		132-134 BEACON ST	BOSTON	MA	2116
0502597000	172 BEACON ST 8	BOSTON	2116 ROBBINS BRETT		172 BEACON ST #8	BOSTON	MA	2116

300-foot Abutters List - Exported from <https://www.boston.gov/abutter-mailing-list-generator>

0502634000	256 BEACON ST 1	BOSTON	2116 ROBERT A CANZANO REVOCABLE TRUS	C/O ROBERT A CANZANO	256 BEACON ST UNIT 3	BOSTON	MA	2116
0502507000	21 BRIMMER ST	BOSTON	2108 ROBERT L BEAL 2007 TRUST	C/O RELATED BEAL	177 MILK ST	BOSTON	MA	2109
0503279000	302 BEACON ST	BOSTON	2116 ROCKLAND BOSTON CONDOMINIUM		302 BEACON ST	BOSTON	MA	2116
0502587000	144 BEACON ST 12	BOSTON	2116 ROETTER MARTYN F	C/O MARTYN ROETTER	144 BEACON ST #12	BOSTON	MA	2116
0503280000	304 BEACON ST 3	BOSTON	2116 ROJAS ENRIQUE A		304 BEACON ST #3	BOSTON	MA	2116
0504078000	211 BAY STATE RD	BOSTON	2215 ROMAN CATH ARCH OF BOS		211 BAY STATE RD	BOSTON	MA	2215
0502602000	184 BEACON ST 4	BOSTON	2116 ROMANO JOHN R		184 BEACON ST #4	BOSTON	MA	2116
0503488000	352 BEACON ST 4	BOSTON	2116 ROME BARBARA S		352 BEACON ST, UNIT 4	BOSTON	MA	2116
0502603000	186 BEACON ST	BOSTON	2116 ROSEN ALBERT J TRSTS	C/O SAUL S GANICK	186 BEACON	BOSTON	MA	2108
0502516000	39 BRIMMER ST	BOSTON	2108 ROSENBLOOM DAVID L		39 BRIMMER	BOSTON	MA	2108
2200598000	7 9 RICHARDSON ST	BRIGHTON	2135 ROSINE L GARABEDIAN REVOCABLE TRUST		7 9 RICHARDSON ST	BRIGHTON	MA	2135
2203427001	35 NEWTON ST	BRIGHTON	2135 RPZ RLTY LAND TRUST LLC TS	C/O ROBERT ZOFFREO	PO BOX 35309	BRIGHTON	MA	2135
0502443000	170 CHARLES ST	BOSTON	2114 RREF II 170 CHARLES LLC	C/O RELATED LP	60 COLUMBUS CI 20TH FL	NEW YORK	NY	10023
0502444000	142 162 CHARLES ST PS2	BOSTON	2114 RREF II BH GARAGE LLC		142-162 CHARLES ST GARAGE	BOSTON	MA	2114
0503749000	642 648 BEACON ST	BOSTON	2215 RREF II KENMORE LESSOR IV LLC	C/O RELATED FUND MANAGEMENT	60 COLUMBUS CIRCLE	NEW YORK	NY	10023
0502748000	157 BEACON ST 1	BOSTON	2116 SALMON KIMBERLEY E		157 BEACON ST, UNIT 1	BOSTON	MA	2116
2200684000	58 LEO M BIRMINGHAM PV	BRIGHTON	2135 SAMIA ASSOCIATES I LLC A MASS LLC		60 LEO M BIRMINGHAM PKWY	BRIGHTON	MA	2135
0503283000	312 BEACON ST	BOSTON	2116 SANCHEZ JEAN PIERRE TS	C/O PRINCE INVESTMENTS LLC	PO BOX 171149	BOSTON	MA	2117
0503520000	413 BEACON ST 3	BOSTON	2115 SANDLER DEBRA A		606 JOHNSTON PL	ALEXANDRIA	VA	22301
0502392000	94 PINCKNEY ST	BOSTON	2114 SANJIV K PATEL REVOCBLE	C/O SANJIV K PATEL	94 PINCKNEY ST	BOSTON	MA	2114
2200651000	30 LEO M BIRMINGHAM PV	BRIGHTON	2135 S-BNK BRIGHTON BIRMINGHM	C/O SANTANDER BANK/LEASE ADMIN	PO BOX 841001	BOSTON	MA	2284
0502594000	166 BEACON ST 3	BOSTON	2116 SCHMAHMANN DAVID R		PO BOX 1094	BROOKLINE	MA	2446
0502439000	110 CHARLES ST 4	BOSTON	2114 SEAMAN JILL		50 CENTRE ST	DOVER	MA	2030
0503722000	37 BAY STATE RD 3	BOSTON	2215 SEGALL STACY J		37 BAY STATE RD, UNIT 3	BOSTON	MA	2215
2202756000	15 SOLDIERS FIELD PL	BRIGHTON	2135 SEGUIN VENTURES LLC MASS LLC	C/O HEIDI VAUGHAN	31 CHICORY RD	WESTFORD	MA	1886
0503485000	346 BEACON ST 2	BOSTON	2116 SELLITTO LUIGI		14 STEARNS DR	NORWOOD	MA	2062
0503712000	17 BAY STATE RD G	BOSTON	2215 SERLIAND INC	C/O S BUYUK	17 BAY STATE RD #G	BOSTON	MA	2215
0502550000	87 BEACON ST 3-R	BOSTON	2108 SETTELMAYER DANIEL		348 CONGRESS PL	PASADENA	CA	91105
0503666000	7 HEREFORD ST	BOSTON	2115 SEVEN HEREFORD ST CONDO ASSN		7 HEREFORD	BOSTON	MA	2115
0503684000	476 BEACON ST PS-C	BOSTON	2115 SHANKMAN MARK J		476 BEACON ST #1	BOSTON	MA	2115
0502583000	138 BEACON ST 8	BOSTON	2116 SHARAN L SCHWARTZBERG 2018	C/O THEODORE SCHWARTZBERG	75 CHESTNUT ST #34	BOSTON	MA	2108
0502494000	22 EMBANKMENT RD 6	BOSTON	2114 SHIN BO KYUNG		10 BURROUGHS RD	LEXINGTON	MA	2420
0502557000	92 BEACON ST 43	BOSTON	2108 SHINA DANIEL E		92 BEACON ST #43	BOSTON	MA	2108
0502676000	261 BEACON ST 33	BOSTON	2116 SHYJAN MICHAEL		47 STONY BROOK RD	WESTFORD	MA	1886
0503518000	417 BEACON ST 2	BOSTON	2115 SILJA PUKITIS IRREVOCABLE TRUST		6413 LURETA ANN LANE	SPRINGFIELD	VA	22150
0502635000	260 258 BEACON ST 3	BOSTON	2116 SILVER YONG-HEE		260 BEACON ST #3	BOSTON	MA	2116
0503678000	462 BEACON ST 21	BOSTON	2115 SLOWHILL REALTY TRUST	C/O GAIL A OKEEFE	22 SLOCUM RD	LEXINGTON	MA	2421
0502593000	164 BEACON ST 6	BOSTON	2116 SOCKOLICH PAULA		375 MOUNTAIN HOME RD	WOODSIDE	CA	94062
2200581000	1270 SOLDIERS FIELD RD	BRIGHTON	2135 SOLDIERS FIELD ENTERPRISES		1270 SOLDIERS FIELD RD	BRIGHTON	MA	2135
0502474000	CHARLES RIVER SQ	BOSTON	2114 SOMMER MELANIE S TS		11 KEYWADIN DR SUITE #100	SALEM	NH	3079
0502511000	29 BRIMMER ST 4 & 5	BOSTON	2108 SORIANO AIDA N		118 MT HOREB ROAD	WARREN	NJ	7059
0300450000	6 WHITTIER PL 9A-6	BOSTON	2114 SOROKO JACQUELINE		6 WHITTIER PL # 9A-6	BOSTON	MA	2114
2200576000	501 507 WESTERN AV	BRIGHTON	2135 SPEEDWAY LAND LLC	C/O ARCHITECTURAL HERITAGE FOI	OLD CITY HALL, 45 SCHOOL ST	BOSTON	MA	2108
0502683000	249 BEACON ST 1	BOSTON	2116 SPELIOS LOUIS C		249 BEACON ST #1	BOSTON	MA	2116
2200565000	385 WESTERN AV	BRIGHTON	2135 STARR SHERMAN H	C/O STARR-FINER-STARR LLP	1280 SOLDIERS FIELD RD	BRIGHTON	MA	2135
2200677000	16 LINCOLN ST	BRIGHTON	2135 STOIA RESIDENTIAL PROPERTIES LLC		36 LINCOLN ST	BRIGHTON	MA	2135
0502540000	124 CHESTNUT ST	BOSTON	2108 STRATOULY DEAN F	C/O D F STRATOULY/CONGRESS GR	33 ARCH ST STE #1100	BOSTON	MA	2110
0503724000	41 BAY STATE RD	BOSTON	2215 SYMPHONY BAY PROPERTIES LLC MASS	C/O ALPHA MANAGEMENT CORP	1249 BEACON ST STE 1	BROOKLINE	MA	2446
0502730000	193 BEACON ST 4	BOSTON	2116 SZCZUROWSKI ANDREW		193 BEACON ST #4	BOSTON	MA	2116
0502538000	130 CHESTNUT ST	BOSTON	2108 SZKUTAK THOMAS J		130 CHESTNUT ST	BOSTON	MA	2108
2202752000	1660 1670 SOLDIERS FIEL	BRIGHTON	2135 TARA 1660 LLC MASS LLC	C/O HAUGHEY COMPANY	1660 SOLDIERS FIELD RD	BRIGHTON	MA	2135
2200562002	1234 SOLDIERS FIELD RD	ALLSTON	2134 TDC 1234 OWNER LLC	C/O STUDIO ALLSTON HOTEL	1234 SOLDIERS FIELD RD	BOSTON	MA	2135
2200562000	1240 SOLDIERS FIELD RD	ALLSTON	2134 TDC 1240 OWNER LLC	C/O THE DAVIS COMPANIES	125 HIGH ST 21ST FLOOR	BOSTON	MA	2110
2200563020	365 WESTERN AV	BRIGHTON	2135 TERRA ASSOCIATES PARTNERSHIP LLC	C/O RONALD CAMPISI	21 PRISCILLA BEACH RD	PLYMOUTH	MA	2360
0300445000	32 239 FRUIT ST	BOSTON	2114 THE GENERAL HOSPITAL CORP	C/O GENERAL HOSPITAL CORP	55 FRUIT ST	BOSTON	MA	2114

300-foot Abutters List - Exported from <https://www.boston.gov/abutter-mailing-list-generator>

0503770000	72 BAY STATE RD	BOSTON	2215 THEMO VICTOR NAUM		72 BAY STATE RD	BOSTON	MA	2215
0503774000	64 BAY STATE RD	BOSTON	2215 THETA XI HOUSING CORP		64 BAY STATE RD	BOSTON	MA	2215
0503282000	310 BEACON ST	BOSTON	2116 THREE 10 BEACON ST CONDO TR	C/O MEDIATE MANAGEMENT CO	189 LINCOLN ST SUITE #3	BOSTON	MA	2111
0503309000	317 313 BEACON ST	BOSTON	2116 THREE 13-317 BEACON STREET		317 BEACON ST #6	BOSTON	MA	2116
0503285000	316 BEACON ST	BOSTON	2116 THREE 16 BEACON ST CONDO TR		316 BEACON	BOSTON	MA	2116
0503303000	329 BEACON ST	BOSTON	2116 THREE 29 BEACON ST CONDO ASSN		329 BEACON	BOSTON	MA	2116
0502442000	129 PINCKNEY ST	BOSTON	2114 THURER ROBERT L		129 PINCKNEY ST	BOSTON	MA	2114
0502684000	247 BEACON ST PS-A	BOSTON	2116 TOLIS REALTY TRUST	C/O GEORGE TOLIS JR	129 MARLBOROUGH ST #C	BOSTON	MA	2116
0503685000	478 BEACON ST 1	BOSTON	2115 TOWNHOUSE STUDIOS LLC	C/O LONG & GORDON	633 TREMONT ST	BOSTON	MA	2118
0504079000	213 217 BAY STATE RD	BOSTON	2215 TRSUTEES OF BOSTON UNIVERSIT		213 BAY STATE RD	BOSTON	MA	2215
0503762000	88 BAY STATE RD	BOSTON	2215 TRUSTEES OF BOSTON UNIVERSITY	C/O OFFICE FINANCIAL AFFAIRS	881 COMMONWEALTH AVE	BOSTON	MA	2215
0502807000	127 BEACON ST OPS	BOSTON	2116 TSAI THEODORE F		129 BEACON ST #22	BOSTON	MA	2116
0503510000	12 HEREFORD ST	BOSTON	2115 TWELVE HEREFORD STREET		12 HEREFORD	BOSTON	MA	2115
0502696000	223 BEACON ST	BOSTON	2116 TWO 23 BEACON ST CONDO TR		223 BEACON ST	BOSTON	MA	2116
0502694000	227 BEACON ST	BOSTON	2116 TWO 27 BEACON STREET		227 BEACON ST	BOSTON	MA	2116
0502682000	251 BEACON ST	BOSTON	2116 TWO 51 BEACON ST CONDO ASSN		251 BEACON	BOSTON	MA	2116
0502675000	263 BEACON ST	BOSTON	2116 TWO 63 BEACON ST CONDO TR		263 BEACON	BOSTON	MA	2116
0502640000	274 BEACON ST	BOSTON	2116 TWO 74 BEACON ST INC	C/O DARTMOUTH GROUP K BOWER	4 PRESTON CT STE 101	BEDFORD	MA	1730
0502669000	275 BEACON ST	BOSTON	2116 TWO 75 BEACON ST CONDO TR		275 BEACON	BOSTON	MA	2116
0502616000	212 BEACON ST	BOSTON	2116 TWO-12 BEACON ST CONDO TR	C/O RICHARD J LEVIN	83 SPEEN ST	NATICK	MA	1760
0503273000	290 BEACON ST 1	BOSTON	2116 TWO-90 BEACON LLC		290 BEACON ST #1	BOSTON	MA	2116
0503717000	27 BAY STATE RD	BOSTON	2215 V AND L TOSI REAL ESTATE TRUST	C/O LINDA TOSI	27 BAY STATE RD	BOSTON	MA	2215
0502604000	188 BEACON ST 5	BOSTON	2116 VIGREUX JOCELYN		188 BEACON ST #5	BOSTON	MA	2116
0502556000	71 BRIMMER ST	BOSTON	2108 VINCENT CLUB THE		71 BRIMMER	BOSTON	MA	2108
2202762001	55 LEO M BIRMINGHAM PV	BRIGHTON	2135 VINFEN CORPORATION	C/O VINFEN CORP	950 CAMBRIDGE ST	CAMBRIDGE	MA	2138
2200587000	19 21 MACKIN ST	BRIGHTON	2135 VISCO BRUNO		176 OAKLEIGH RD	NEWTON	MA	2458
0502447000	117 REVERE ST	BOSTON	2114 VITAGLIANO FRANCIS		117 REVERE	BOSTON	MA	2114
0502393000	PINCKNEY ST	BOSTON	2114 VO TRAM H		84 PINCKNEY STREET	BOSTON	MA	2114
0502752000	149 BEACON ST 5	BOSTON	2116 WANG SONG	C/O SONG WANG	149 BEACON ST #5 ST	BOSTON	MA	2116
0503301000	333 BEACON ST 4	BOSTON	2116 WANG ZHENG JOAN		12646 TRAVILAH ROAD	POTOMAC	MD	20854
0503512000	429 BEACON ST	BOSTON	2115 WATKINS CAPITAL GROUP LLC MASS LLC		429 BEACON ST	BOSTON	MA	2115
0502661000	291 BEACON ST	BOSTON	2116 WEISMAN MARILYN TS	C/O SBC2 PROPERTIES	28 DAMRELL ST SUITE 104	SOUTH BOSTON	MA	2127
0503275000	294 BEACON ST 1	BOSTON	2116 WEISS PETER		294 BEACON ST, #1	BOSTON	MA	2116
2200558001	EVERETT ST	ALLSTON	2134 WESTERN AVENUE JOINT	C/O WESTERN AVENUE JOINT VENT	222 BERKELEY ST	BOSTON	MA	2116
2200551000	1170 SOLDIERS FIELD RD	ALLSTON	2134 WESTNGHSE BRDCSTNG CO INC	RYAN & CO C/OC TERRI WHITE	2800 POST OAK BLVD STE 4200	HOUSTON	TX	77056
0502469000	5 CHARLES RIVER SQ	BOSTON	2114 WESTRA CHRISTIAN J		5 CHARLES RIVER SQUARE	BOSTON	MA	2114
0502536000	134 CHESTNUT ST	BOSTON	2108 WISNESKI FRANK V TS		134 CHESTNUT ST	BOSTON	MA	2108
0503462000	383 BEACON ST C	BOSTON	2116 WOOD DEXTER E JR	KATHLEEN M MURPHY	383 BEACON ST # C	BOSTON	MA	2116
0503721000	35 BAY STATE RD 4R	BOSTON	2215 WU HENRY Y		35 BAY STATE RD #4R	BOSTON	MA	2215
2200585000	11 13 MACKIN ST	BRIGHTON	2135 WU QI LONG		13 MACKIN ST	BRIGHTON	MA	2135
0503299000	337 BEACON ST	BOSTON	2116 YAFFE PETER	LEWIS SASSOON/ 337 BEACON RLTY	84 STATE ST 8TH FLOOR	BOSTON	MA	2109
0502368000	158 MT VERNON ST	BOSTON	2108 YOO NICHOLAS E		158 MT VERNON ST	BOSTON	MA	2108
0502575000	120 BEACON ST PS-2	BOSTON	2116 YOUNG KATHLEEN T		120 BEACON ST, UNIT 7	BOSTON	MA	2116
0503308000	319 BEACON ST	BOSTON	2116 ZAIGER ADAM M		319 BEACON ST	BOSTON	MA	2116
0502467000	6 CHARLES RIVER SQ	BOSTON	2114 ZARINS LAIMA I		6 CHARLES RIVER SQ	BOSTON	MA	2114
0503497000	2 GLOUCESTER ST 4	BOSTON	2115 ZHU QIAN		404 BEACON ST #4	BOSTON	MA	2115
0502465000	7 CHARLES RIVER SQ	BOSTON	2114 ZUROMSKIS J MICHAEL		7 CHARLES RIVER SQ	BOSTON	MA	2114

APPENDIX C

Figures

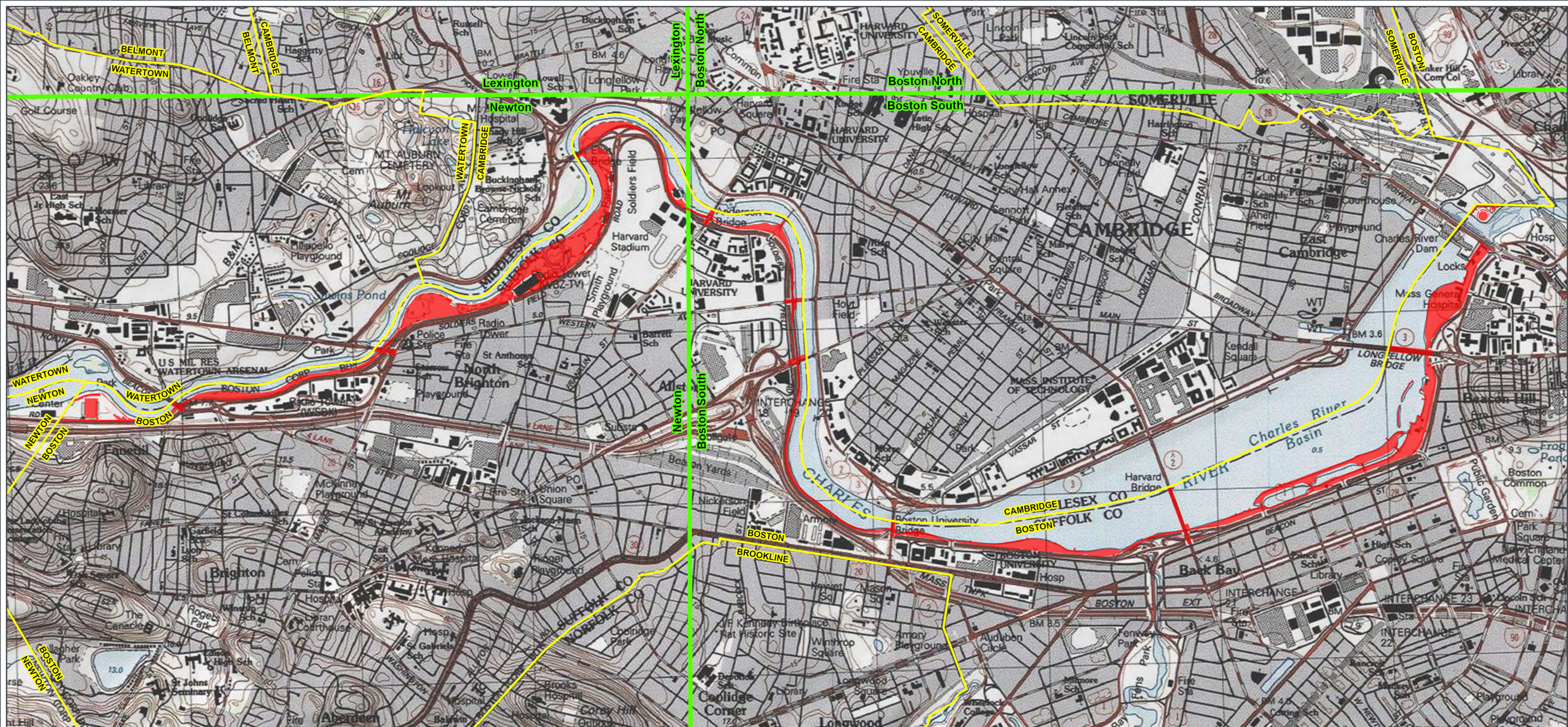

CHARLES RIVER VMP PERMITTING AND IMPLEMENTATION PROJECT
Figure 1. USGS Topographic Map

- Project Area
- Municipal Boundary
- 7.5' USGS Quadrangle Boundary



Boston, MA
 USGS 7.5' Quadrangles: Newton and Boston South
 NAD 1983 StatePlane Massachusetts Mainland FIPS 2001 Feet
 71.1181°W 42.3607°N

0 1,000 2,000 Feet
 0 250 500 Meters

1:24,000

Base Map: ESRI ArcGIS Online, accessed May 2022
 Updated: 5/4/2022
 Project No. 70690



CHARLES RIVER VMP PERMITTING AND IMPLEMENTATION PROJECT
Figure 2. Outstanding Resource Waters

- Outstanding Resource Waters
- Project Area
- Municipal Boundary

Boston, MA
 USGS 7.5' Quadrangles: Newton and Boston South
 NAD 1983 StatePlane Massachusetts Mainland FIPS 2001 Feet
 71.1181°W 42.3607°N

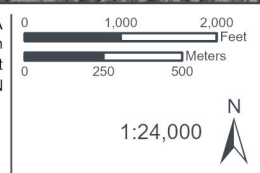

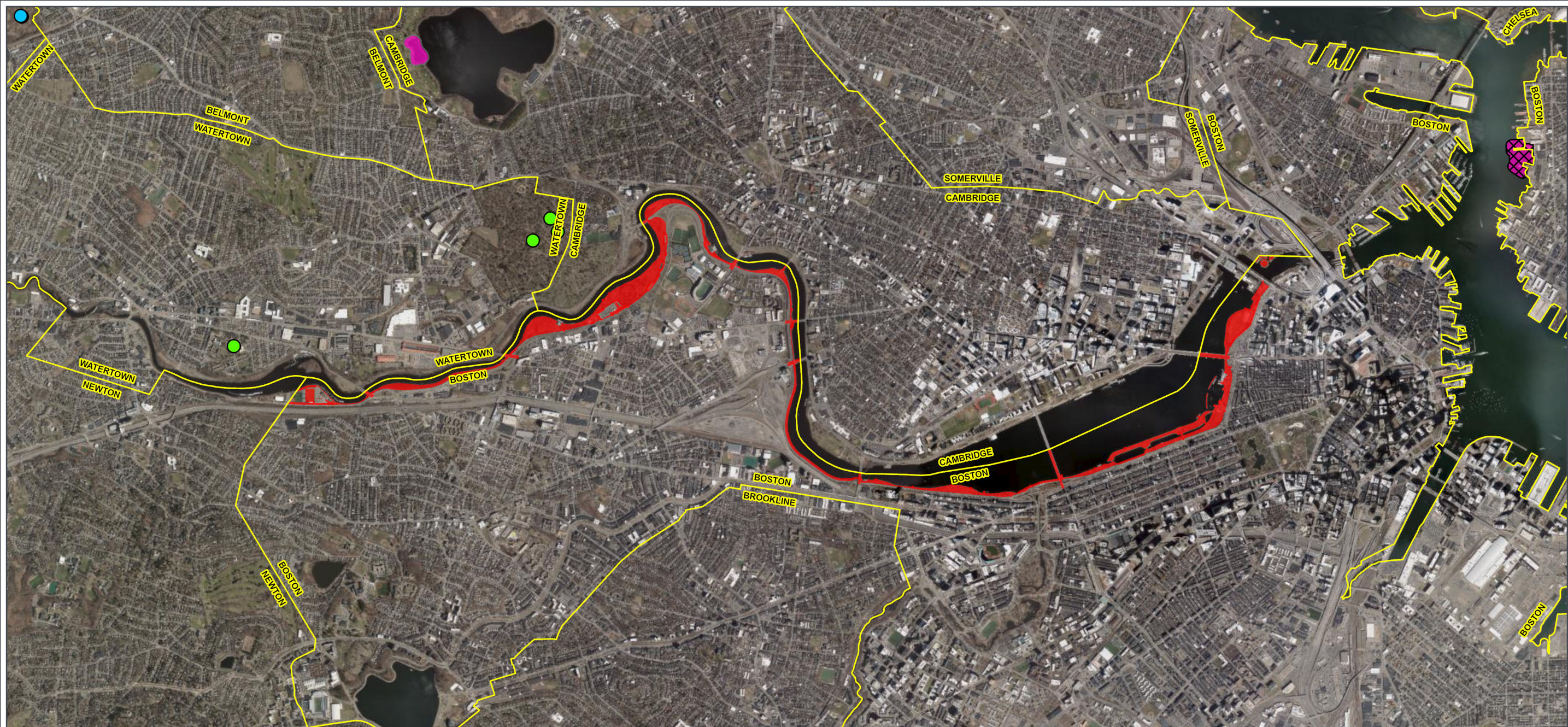

CHARLES RIVER VMP PERMITTING AND IMPLEMENTATION PROJECT
Figure 3. NHESP

- Certified Vernal Pool
- Potential Vernal Pool
- Estimated Habitats of Rare Wildlife
- Priority Habitats of Rare Species
- Project Area
- Municipal Boundary

Boston, MA
 USGS 7.5' Quadrangles: Newton and Boston South
 NAD 1983 StatePlane Massachusetts Mainland FIPS 2001 Feet
 71.1181°W 42.3607°N

0 1,000 2,000 Feet
 0 250 500 Meters

1:35,000

Base Map: ESRI ArcGIS Online, accessed May 2022
 Updated: 5/4/2022
 Project No. 70690

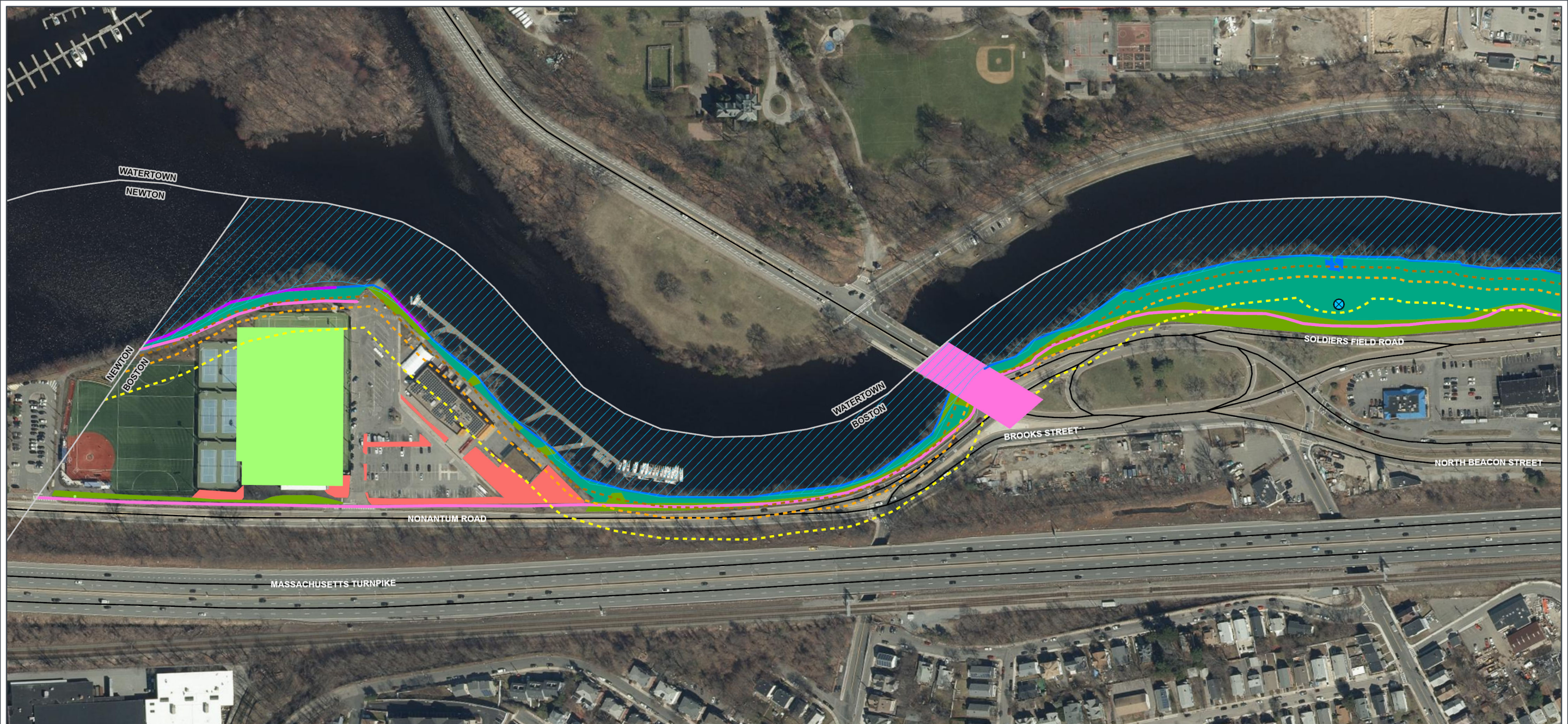

CHARLES RIVER VMP PERMITTING AND IMPLEMENTATION PROJECT
Figure 4. Routine Maintenance and Special Events Trimming
 Map 1 of 11



- Boat Dock Area
- ⊗ Culvert
- 25' Riverfront Area
- 100' Buffer Zone
- Delineated Bank
- Fourth of July Trimming Zone
- Head of Charles Trimming Zone

- Major Road
- Waterfront Area
- Bordering Land Subject To Flooding
- Municipal Boundary
- Delineated Wetland**
- Bordering Vegetated Wetland
- Isolated Vegetated Wetland

- Landscape Type**
- CI - Circulation
 - GI - Green Infrastructure
 - L - Lawn
 - LA - Landscape Area
 - M - Meadow
 - RE - River's Edge

- S - Structure
- T - Woodland

Boston, MA
 USGS 7.5' Quadrangles: Newton and Boston South
 NAD 1983 StatePlane Massachusetts Mainland FIPS 2001 Feet
 71.1628°W 42.3589°N

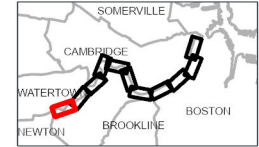

0 120 240 Feet
 0 30 60 Meters
 1:3,000
 Base Map: ESRI ArcGIS Online, accessed May 2022

Updated: 5/3/2022
 Project No. 70690

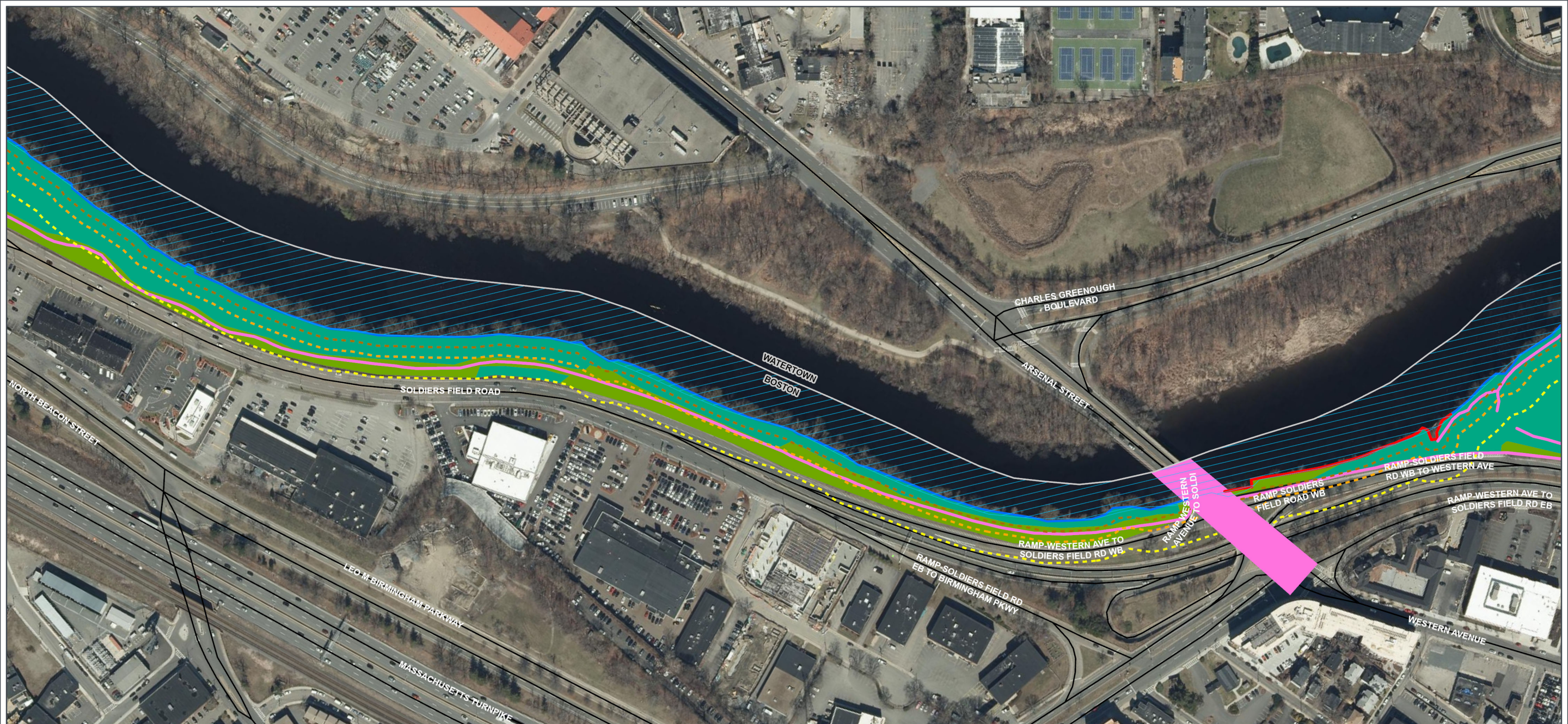

CHARLES RIVER VMP PERMITTING AND IMPLEMENTATION PROJECT
Figure 4. Routine Maintenance and Special Events Trimming
 Map 2 of 11



- Boat Dock Area
- ⊗ Culvert
- - - 25' Riverfront Area
- - - 100' Buffer Zone
- Delimited Bank
- - - Fourth of July Trimming Zone
- Head of Charles Trimming Zone

- Major Road
- - - Waterfront Area
- ▨ Bordering Land Subject To Flooding
- Municipal Boundary
- Delimited Wetland**
- ▨ Bordering Vegetated Wetland
- ▨ Isolated Vegetated Wetland

- Landscape Type**
- CI - Circulation
 - GI - Green Infrastructure
 - L - Lawn
 - LA - Landscape Area
 - M - Meadow
 - RE - River's Edge

- S - Structure
- T - Woodland

Boston, MA
 USGS 7.5' Quadrangles: Newton and Boston South
 NAD 1983 StatePlane Massachusetts Mainland FIPS 2001 Feet
 71.1506°W 42.361°N

Base Map: ESRI ArcGIS Online, accessed May 2022

0 120 240 Feet
 0 30 60 Meters

1:3,000

Updated: 5/3/2022
 Project No. 70690

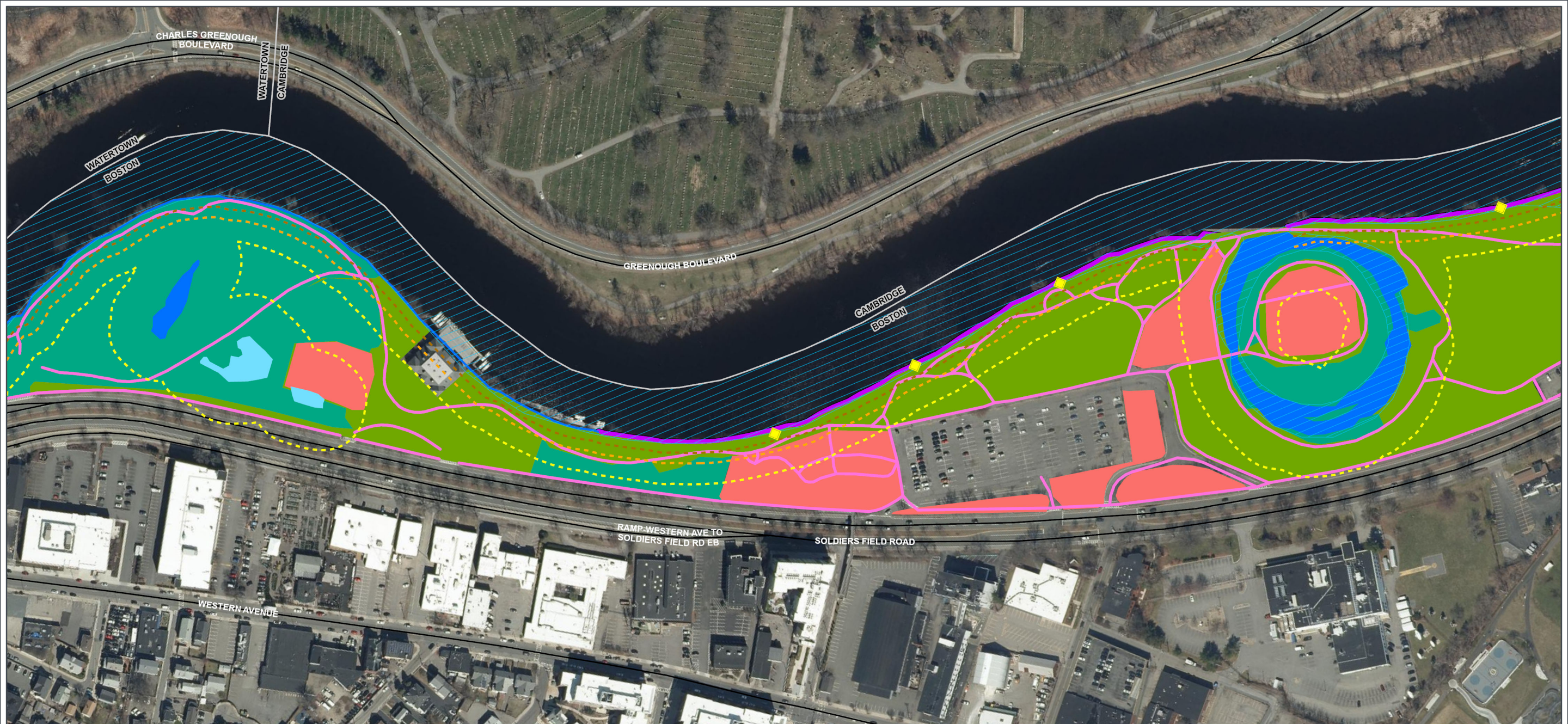

CHARLES RIVER VMP PERMITTING AND IMPLEMENTATION PROJECT
Figure 4. Routine Maintenance and Special Events Trimming
 Map 3 of 11



- Boat Dock Area
- ⊗ Culvert
- 25' Riverfront Area
- 100' Buffer Zone
- Delineated Bank
- Fourth of July Trimming Zone
- Head of Charles Trimming Zone

- Major Road
- Waterfront Area
- Bordering Land Subject To Flooding
- Municipal Boundary
- Delineated Wetland**
- Bordering Vegetated Wetland
- Isolated Vegetated Wetland

- Landscape Type**
- CI - Circulation
 - GI - Green Infrastructure
 - L - Lawn
 - LA - Landscape Area
 - M - Meadow
 - RE - River's Edge

- S - Structure
- T - Woodland

Boston, MA
 USGS 7.5' Quadrangles: Newton and Boston South
 NAD 1983 StatePlane Massachusetts Mainland FIPS 2001 Feet
 71.1387°W 42.3649°N

Base Map: ESRI ArcGIS Online, accessed May 2022

1:3,000

Updated: 5/3/2022
 Project No. 70690

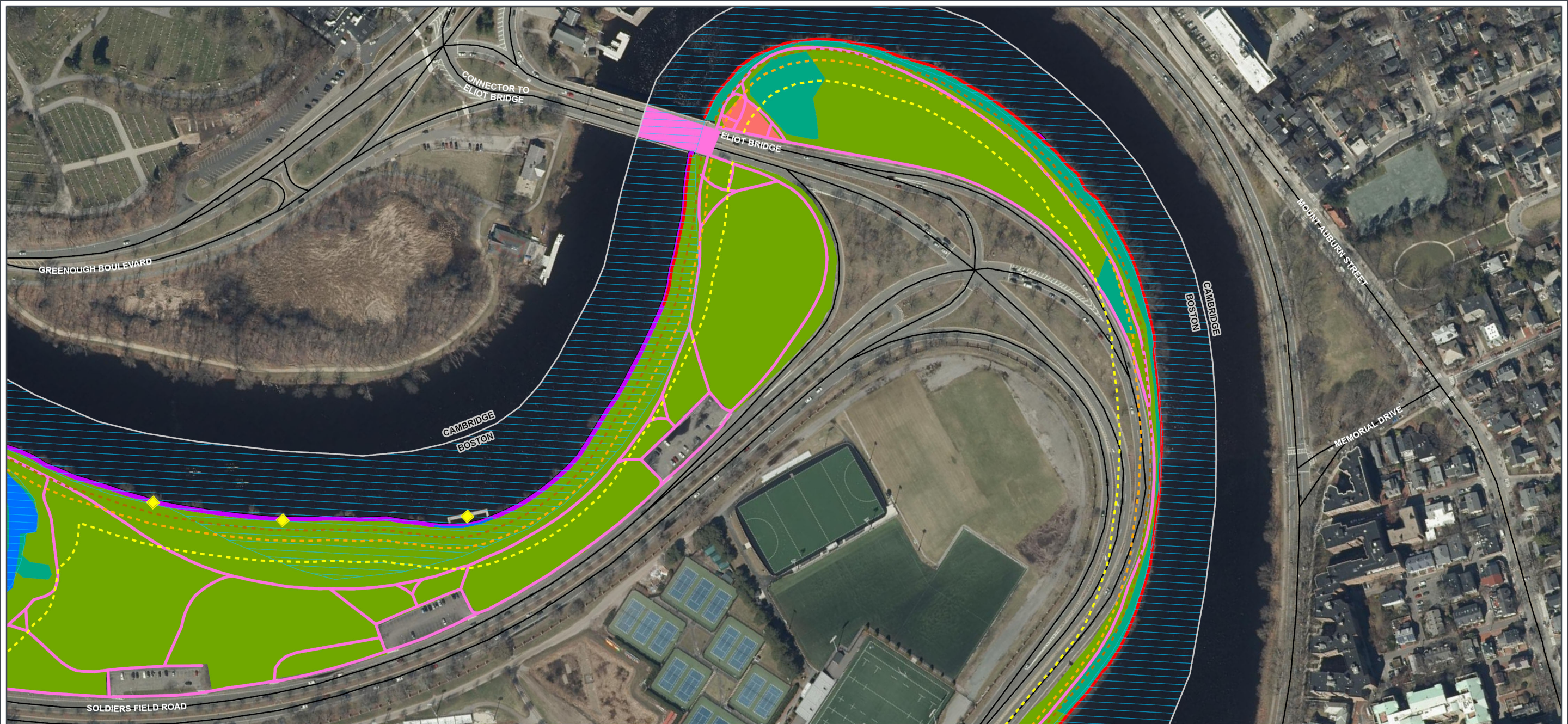

CHARLES RIVER VMP PERMITTING AND IMPLEMENTATION PROJECT
Figure 4. Routine Maintenance and Special Events Trimming
 Map 4 of 11



- Boat Dock Area
- ⊗ Culvert
- - - 25' Riverfront Area
- - - - - 100' Buffer Zone
- Delineated Bank
- ⋯ Fourth of July Trimming Zone
- Head of Charles Trimming Zone

- Major Road
- - - Waterfront Area
- Bordering Land Subject To Flooding
- Municipal Boundary
- Delineated Wetland**
- Bordering Vegetated Wetland
- Isolated Vegetated Wetland

- Landscape Type**
- CI - Circulation
 - GI - Green Infrastructure
 - L - Lawn
 - LA - Landscape Area
 - M - Meadow
 - RE - River's Edge

- S - Structure
- T - Woodland

USGS 7.5' Quadrangles: Newton and Boston South
 NAD 1983 StatePlane Massachusetts Mainland FIPS 2001 Feet
 71.1305°W 42.3713°N

Base Map: ESRI ArcGIS Online, accessed May 2022

Boston, MA
 0 120 240 Feet
 0 30 60 Meters
 1:3,000

Updated: 5/3/2022
 Project No. 70690

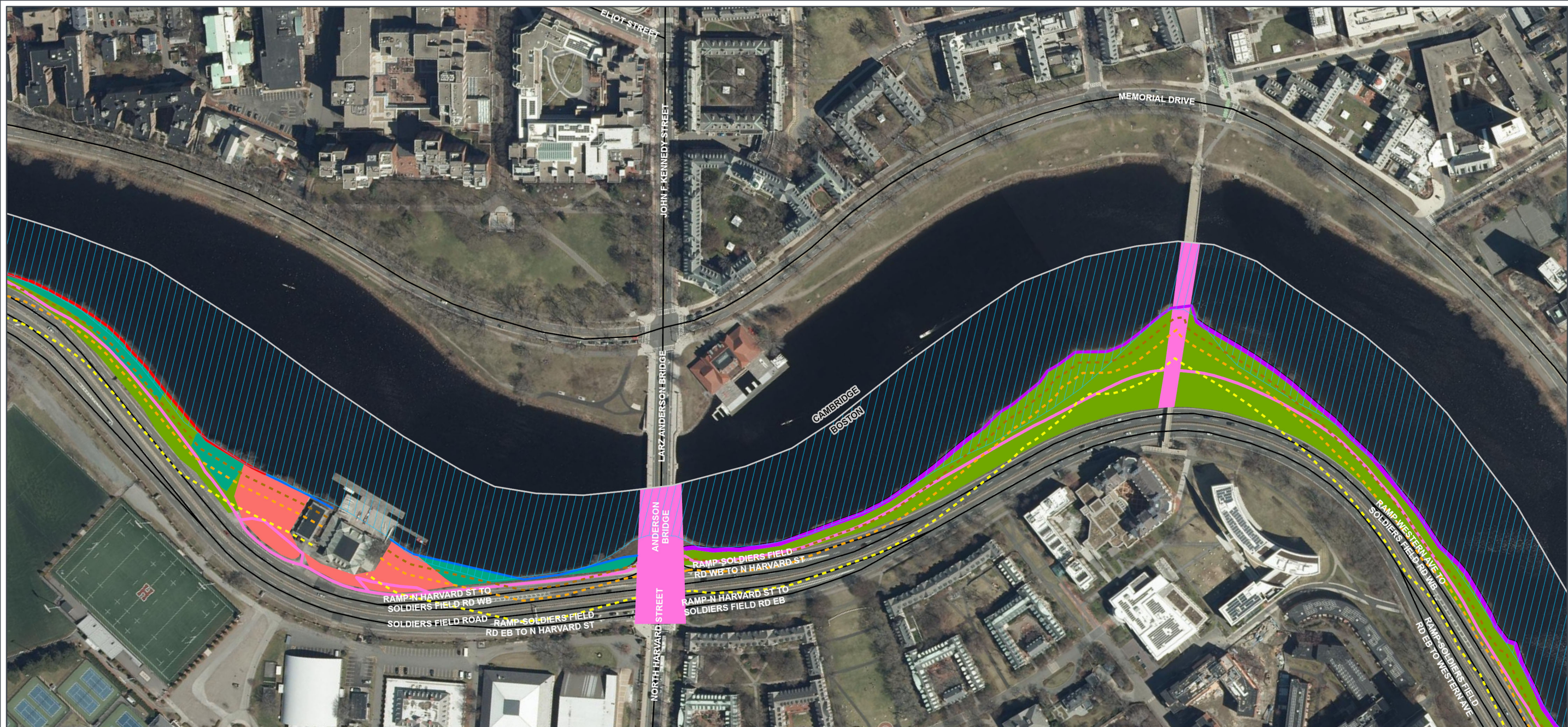

CHARLES RIVER VMP PERMITTING AND IMPLEMENTATION PROJECT
Figure 4. Routine Maintenance and Special Events Trimming
 Map 5 of 11



- Boat Dock Area
- ⊗ Culvert
- - - 25' Riverfront Area
- - - 100' Buffer Zone
- Delineated Bank
- - - Fourth of July Trimming Zone
- Head of Charles Trimming Zone

- Major Road
- - - Waterfront Area
- ▨ Bordering Land Subject To Flooding
- ▭ Municipal Boundary
- Delineated Wetland**
- ▭ Bordering Vegetated Wetland
- ▭ Isolated Vegetated Wetland

- Landscape Type**
- ▭ CI - Circulation
 - ▭ GI - Green Infrastructure
 - ▭ L - Lawn
 - ▭ LA - Landscape Area
 - ▭ M - Meadow
 - ▭ RE - River's Edge

- ▭ S - Structure
- ▭ T - Woodland

Boston, MA
 USGS 7.5' Quadrangles: Newton and Boston South
 NAD 1983 StatePlane Massachusetts Mainland FIPS 2001 Feet
 71.1217°W 42.3692°N

Base Map: ESRI ArcGIS Online, accessed May 2022

0 120 240 Feet
 0 30 60 Meters

1:3,000

Updated: 5/3/2022
 Project No. 70690

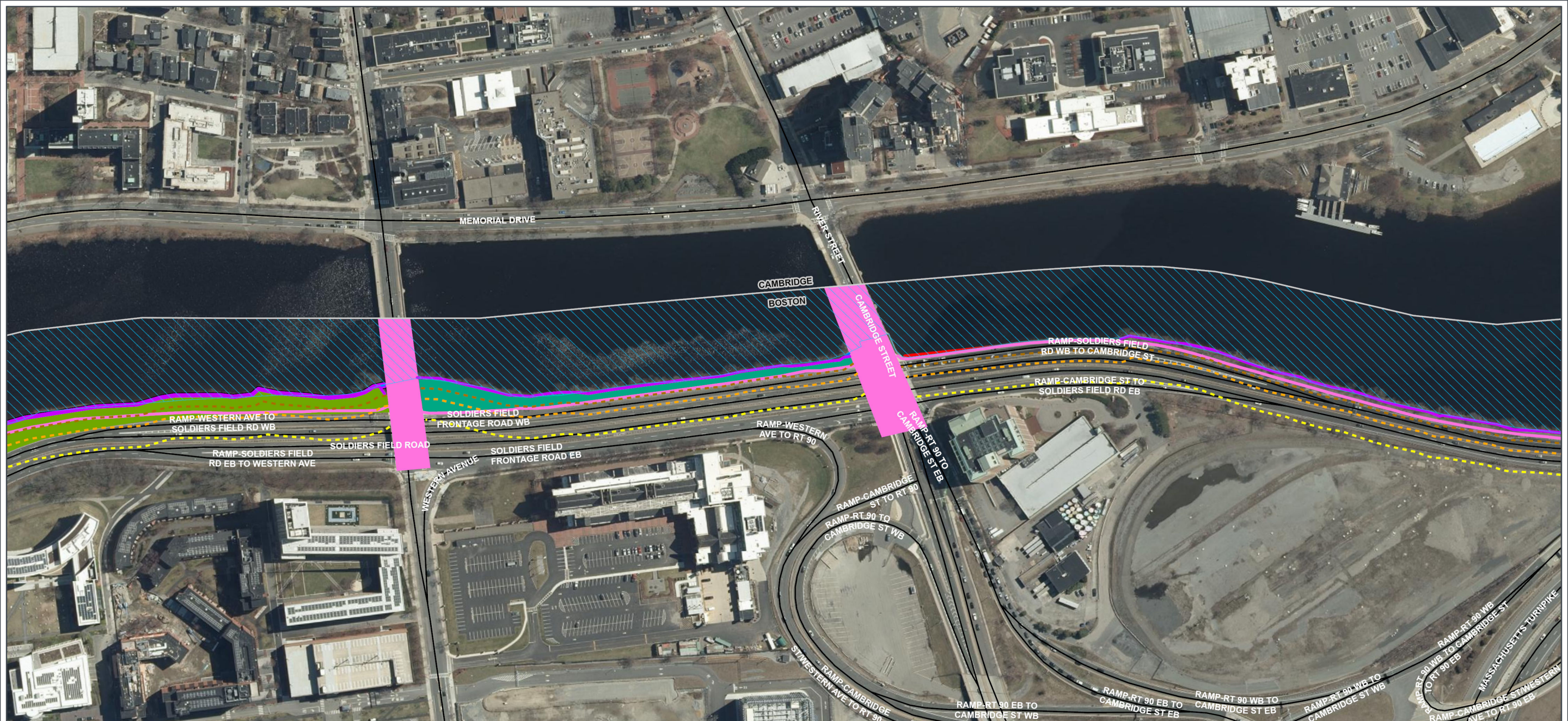

CHARLES RIVER VMP PERMITTING AND IMPLEMENTATION PROJECT
Figure 4. Routine Maintenance and Special Events Trimming
 Map 6 of 11

- Boat Dock Area
- ⊗ Culvert
- - - 25' Riverfront Area
- - - 100' Buffer Zone
- Delineated Bank
- ⋯ Fourth of July Trimming Zone
- Head of Charles Trimming Zone

- Major Road
- - - Waterfront Area
- ▨ Bordering Land Subject To Flooding
- Municipal Boundary
- Delineated Wetland**
- Bordering Vegetated Wetland
- Isolated Vegetated Wetland

- Landscape Type**
- CI - Circulation
 - GI - Green Infrastructure
 - L - Lawn
 - LA - Landscape Area
 - M - Meadow
 - RE - River's Edge

- S - Structure
- T - Woodland

Boston, MA
 USGS 7.5' Quadrangles: Newton and Boston South
 NAD 1983 StatePlane Massachusetts Mainland FIPS 2001 Feet
 71.1174°W 42.3617°N

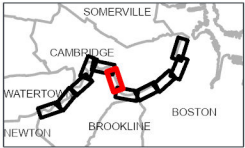

Base Map: ESRI ArcGIS Online, accessed May 2022
 Updated: 5/3/2022
 Project No. 70690

0 120 240 Feet
 0 30 60 Meters
 1:3,000

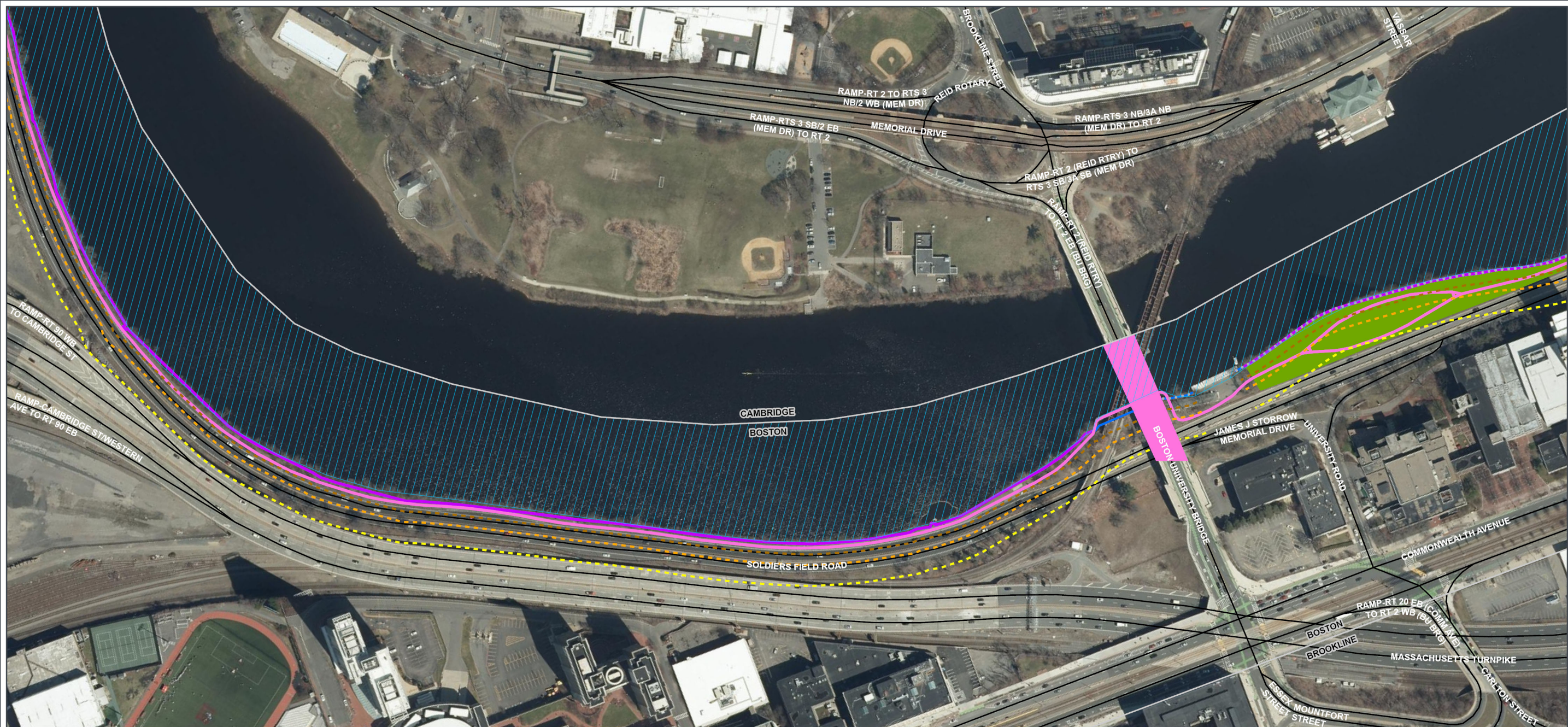

CHARLES RIVER VMP PERMITTING AND IMPLEMENTATION PROJECT
Figure 4. Routine Maintenance and Special Events Trimming
 Map 7 of 11



- Boat Dock Area
- ⊗ Culvert
- 25' Riverfront Area
- 100' Buffer Zone
- Delineated Bank
- Fourth of July Trimming Zone
- Head of Charles Trimming Zone

- Major Road
- Waterfront Area
- Bordering Land Subject To Flooding
- Municipal Boundary
- Delineated Wetland**
- Bordering Vegetated Wetland
- Isolated Vegetated Wetland

- Landscape Type**
- CI - Circulation
 - GI - Green Infrastructure
 - L - Lawn
 - LA - Landscape Area
 - M - Meadow
 - RE - River's Edge

- S - Structure
- T - Woodland

Boston, MA
 USGS 7.5' Quadrangles: Newton and Boston South
 NAD 1983 StatePlane Massachusetts Mainland FIPS 2001 Feet
 71.1133°W 42.3535°N

Base Map: ESRI ArcGIS Online, accessed May 2022

0 120 240 Feet
 0 30 60 Meters

1:3,000

Updated: 5/3/2022
 Project No. 70690



CHARLES RIVER VMP PERMITTING AND IMPLEMENTATION PROJECT
Figure 4. Routine Maintenance and Special Events Trimming
 Map 8 of 11



- Boat Dock Area
- ⊗ Culvert
- - - 25' Riverfront Area
- - - 100' Buffer Zone
- Delineated Bank
- - - Fourth of July Trimming Zone
- Head of Charles Trimming Zone

- Major Road
- - - Waterfront Area
- ▨ Bordering Land Subject To Flooding
- Municipal Boundary
- Delineated Wetland**
- Bordering Vegetated Wetland
- Isolated Vegetated Wetland

- Landscape Type**
- CI - Circulation
 - GI - Green Infrastructure
 - L - Lawn
 - LA - Landscape Area
 - M - Meadow
 - RE - River's Edge

- S - Structure
- T - Woodland

Boston, MA
 USGS 7.5' Quadrangles: Newton and Boston South
 NAD 1983 StatePlane Massachusetts Mainland FIPS 2001 Feet
 71.1006°W 42.3517°N

Base Map: ESRI ArcGIS Online, accessed May 2022

0 120 240 Feet
 0 30 60 Meters

1:3,000

Updated: 5/3/2022
 Project No. 70690



CHARLES RIVER VMP PERMITTING AND IMPLEMENTATION PROJECT
Figure 4. Routine Maintenance and Special Events Trimming
 Map 9 of 11



- Boat Dock Area
- ⊗ Culvert
- - - 25' Riverfront Area
- - - 100' Buffer Zone
- Delineated Bank
- - - Fourth of July Trimming Zone
- Head of Charles Trimming Zone

- Major Road
- - - Waterfront Area
- ▨ Bordering Land Subject To Flooding
- Municipal Boundary
- Delineated Wetland**
- Bordering Vegetated Wetland
- Isolated Vegetated Wetland

- Landscape Type**
- CI - Circulation
 - GI - Green Infrastructure
 - L - Lawn
 - LA - Landscape Area
 - M - Meadow
 - RE - River's Edge

- S - Structure
- T - Woodland

Boston, MA
 USGS 7.5' Quadrangles: Newton and Boston South
 NAD 1983 StatePlane Massachusetts Mainland FIPS 2001 Feet
 71.088°W 42.3534°N

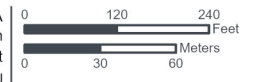
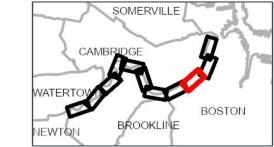

1:3,000

Base Map: ESRI ArcGIS Online, accessed May 2022

Updated: 5/3/2022
 Project No. 70690



CHARLES RIVER VMP PERMITTING AND IMPLEMENTATION PROJECT
Figure 4. Routine Maintenance and Special Events Trimming
 Map 10 of 11



- Boat Dock Area
- ⊗ Culvert
- - - 25' Riverfront Area
- - - 100' Buffer Zone
- Delineated Bank
- - - Fourth of July Trimming Zone
- Head of Charles Trimming Zone

- Major Road
- - - Waterfront Area
- ▨ Bordering Land Subject To Flooding
- Municipal Boundary
- Delineated Wetland**
- Bordering Vegetated Wetland
- Isolated Vegetated Wetland

- Landscape Type**
- CI - Circulation
 - GI - Green Infrastructure
 - L - Lawn
 - LA - Landscape Area
 - M - Meadow
 - RE - River's Edge

- S - Structure
- T - Woodland

Boston, MA
 USGS 7.5' Quadrangles: Newton and Boston South
 NAD 1983 StatePlane Massachusetts Mainland FIPS 2001 Feet
 71.0763°W 42.357°N

Base Map: ESRI ArcGIS Online, accessed May 2022

1:3,000

Updated: 5/3/2022
 Project No. 70690

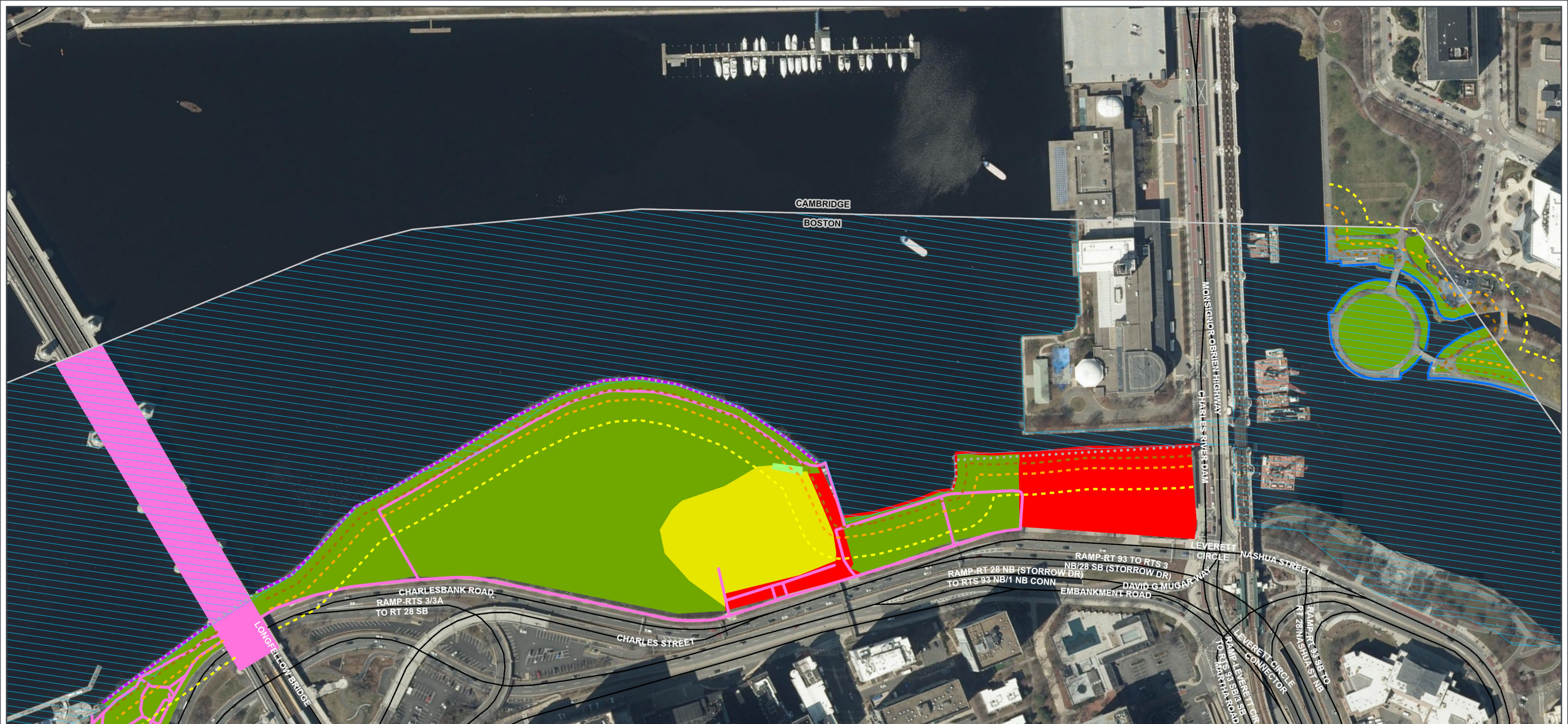

CHARLES RIVER VMP PERMITTING AND IMPLEMENTATION PROJECT
Figure 4. Routine Maintenance and Special Events Trimming
 Map 11 of 11



- Boat Dock Area
- Culvert
- 25' Riverfront Area
- 100' Buffer Zone
- Delineated Bank
- Fourth of July Trimming Zone
- Head of Charles Trimming Zone

- Major Road
- Waterfront Area
- Bordering Land Subject To Flooding
- Municipal Boundary
- Delineated Wetland**
- Bordering Vegetated Wetland
- Isolated Vegetated Wetland

- Landscape Type**
- CI - Circulation
 - GI - Green Infrastructure
 - L - Lawn
 - LA - Landscape Area
 - M - Meadow
 - RE - River's Edge

- S - Structure
- T - Woodland

Boston, MA
 USGS 7.5' Quadrangles: Newton and Boston South
 NAD 1983 StatePlane Massachusetts Mainland FIPS 2001 Feet
 71.0719°W 42.3652°N

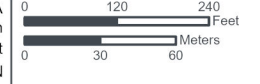
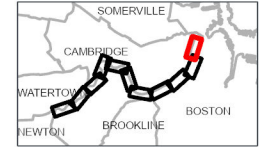

1:3,000

Base Map: ESRI ArcGIS Online, accessed May 2022

Updated: 5/3/2022
 Project No. 70690

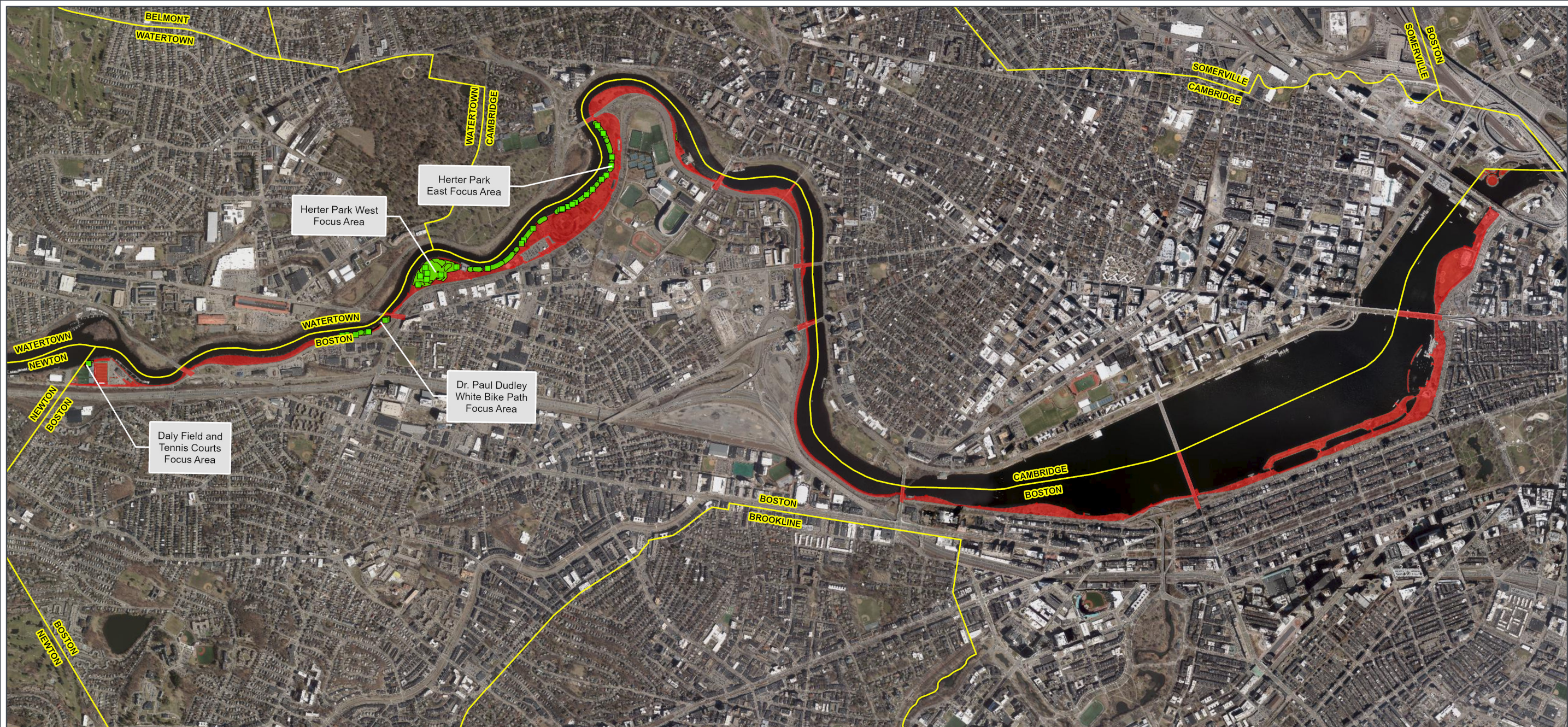

CHARLES RIVER VMP PERMITTING AND IMPLEMENTATION PROJECT
Figure 5. Wetland Resources and Invasive Plant Management Areas Overview

- Invasive Plant Population
- Project Area
- Municipal Boundary

Boston, MA
 USGS 7.5' Quadrangles: Newton and Boston South
 NAD 1983 StatePlane Massachusetts Mainland FIPS 2001 Feet
 71.1188°W 42.3588°N

0 1,000 2,000 Feet
 0 250 500 Meters

1:24,000

Base Map: ESRI ArcGIS Online, accessed May 2022

Updated: 5/4/2022
 Project No. 70690

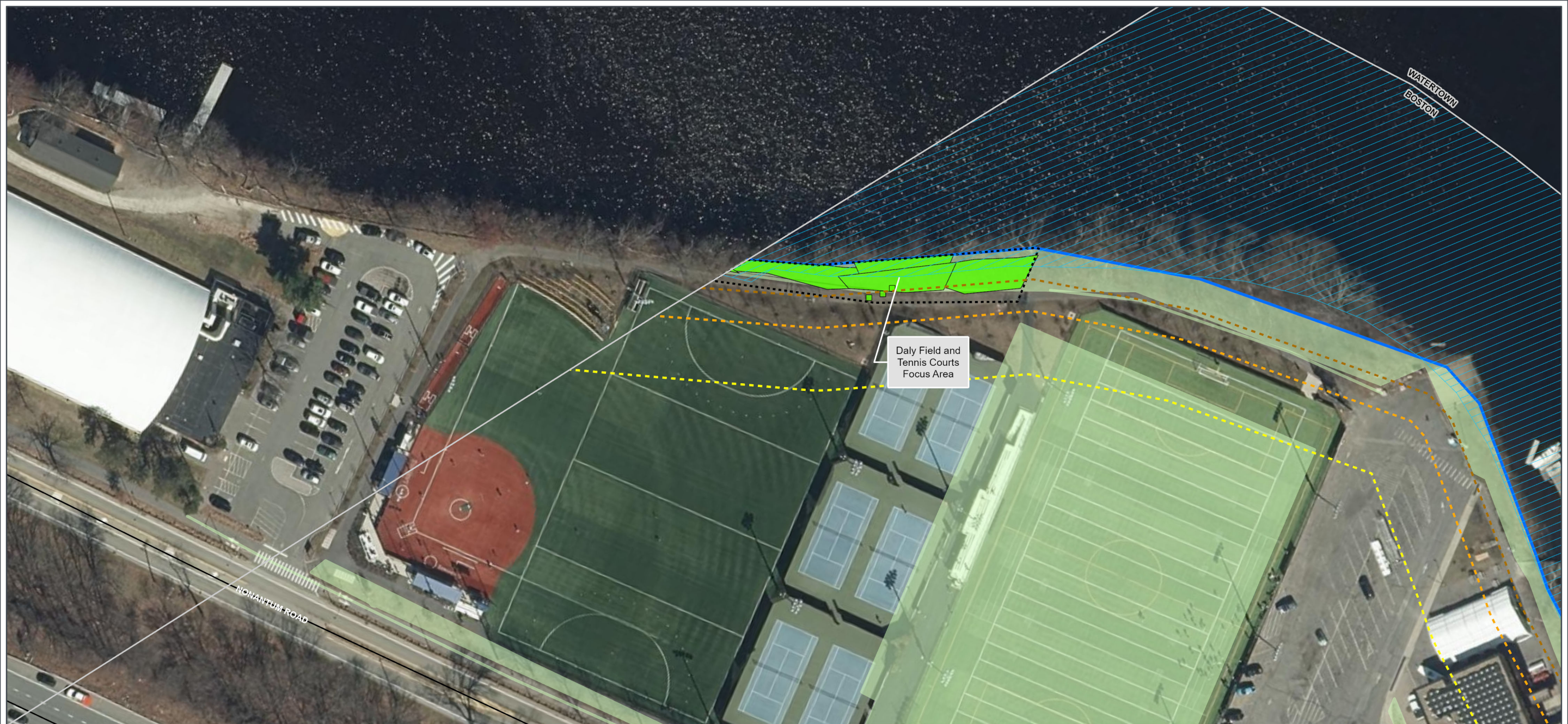

CHARLES RIVER VMP PERMITTING AND IMPLEMENTATION PROJECT
Figure 5. Wetland Resources and Invasive Plant Management Areas
 Map 1 of 7

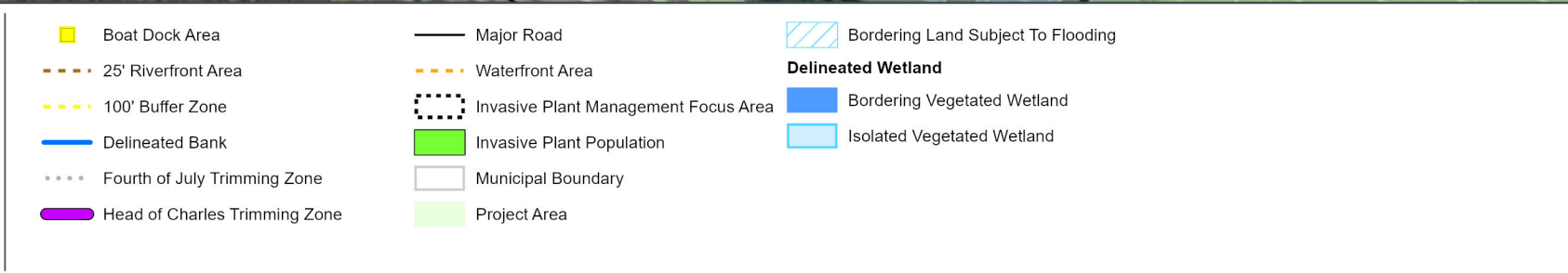

Boston, MA
 USGS 7.5' Quadrangles: Newton and Boston South
 NAD 1983 StatePlane Massachusetts Mainland FIPS 2001 Feet
 71.1682°W 42.3589°N

1:1,000

Base Map: ESRI ArcGIS Online, accessed May 2022
 Updated: 5/3/2022
 Project No. 70690

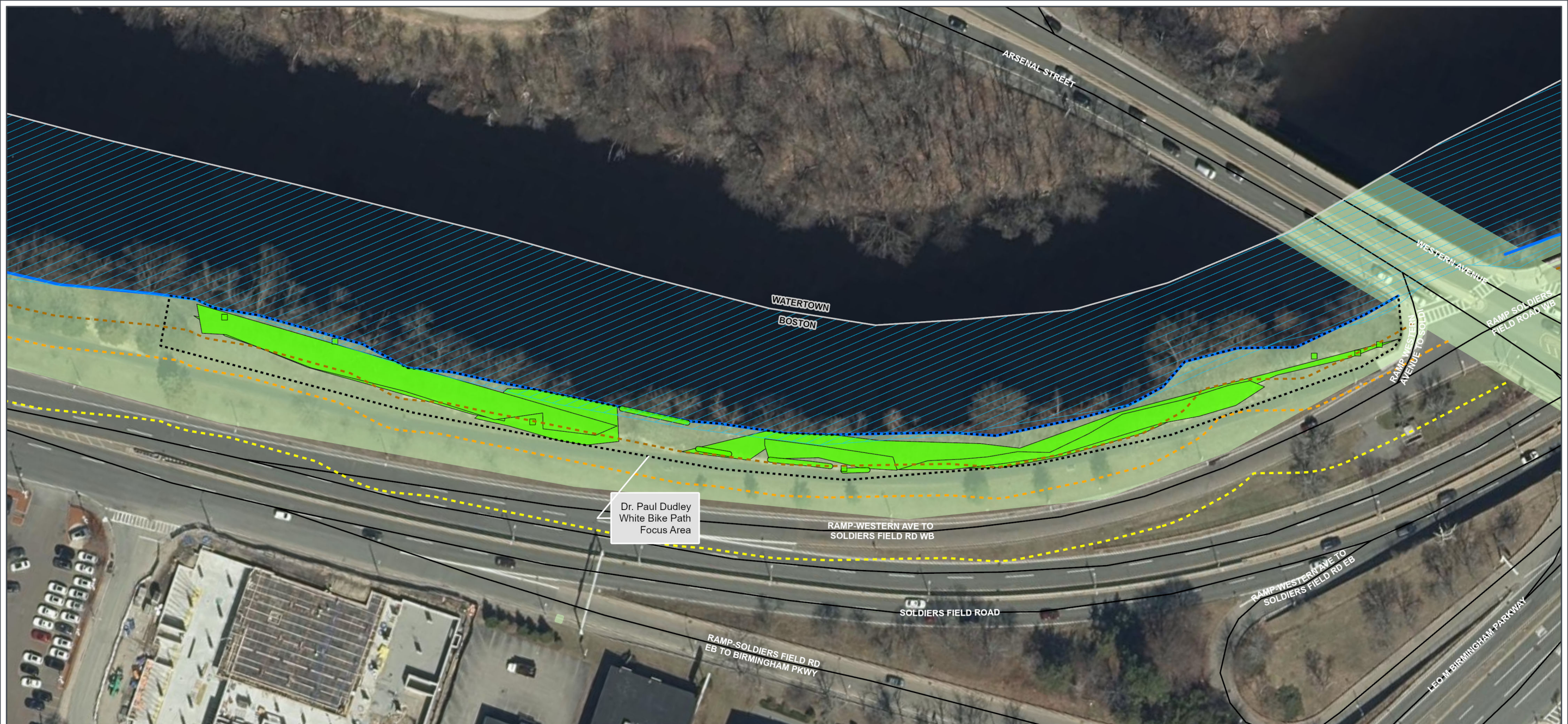

CHARLES RIVER VMP PERMITTING AND IMPLEMENTATION PROJECT
Figure 5. Wetland Resources and Invasive Plant Management Areas
 Map 2 of 7



- Boat Dock Area
- 25' Riverfront Area
- 100' Buffer Zone
- Delineated Bank
- Fourth of July Trimming Zone
- Head of Charles Trimming Zone
- Major Road
- Waterfront Area
- Invasive Plant Management Focus Area
- Invasive Plant Population
- Municipal Boundary
- Project Area

- Bordering Land Subject To Flooding
- Delineated Wetland**
- Bordering Vegetated Wetland
- Isolated Vegetated Wetland

Boston, MA
 USGS 7.5' Quadrangles: Newton and Boston South
 NAD 1983 StatePlane Massachusetts Mainland FIPS 2001 Feet
 71.1485°W 42.361°N

Base Map: ESRI ArcGIS Online, accessed May 2022

0 40 80 Feet
 0 10 20 Meters

1:1,000

Updated: 5/3/2022
 Project No. 70690

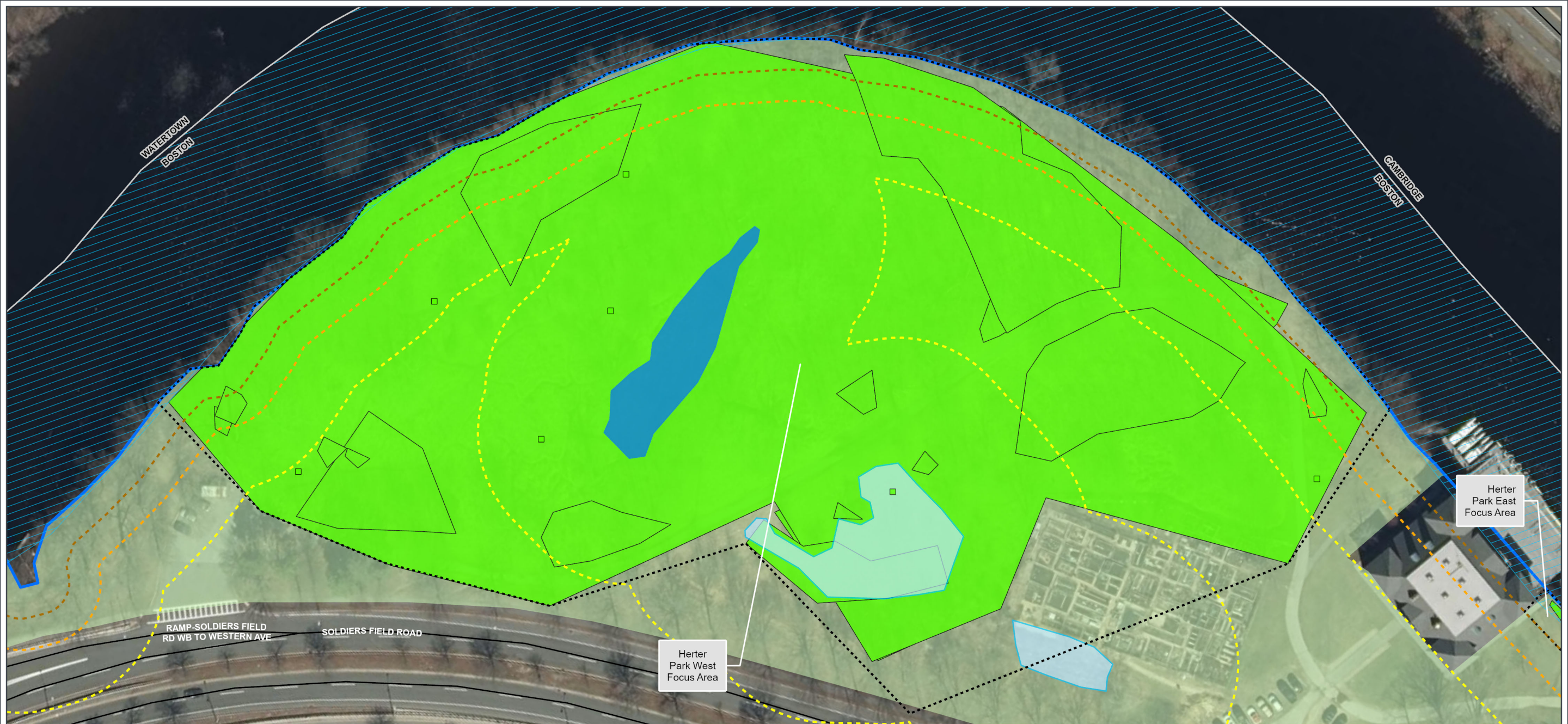

- Boat Dock Area
- 25' Riverfront Area
- 100' Buffer Zone
- Delineated Bank
- Fourth of July Trimming Zone
- Head of Charles Trimming Zone

- Major Road
- Waterfront Area
- Invasive Plant Management Focus Area
- Invasive Plant Population
- Municipal Boundary
- Project Area

- Bordering Land Subject To Flooding
- Delineated Wetland**
- Bordering Vegetated Wetland
- Isolated Vegetated Wetland

Boston, MA
 USGS 7.5' Quadrangles: Newton and Boston South
 NAD 1983 StatePlane Massachusetts Mainland FIPS 2001 Feet
 71.1436°W 42.3639°N

Base Map: ESRI ArcGIS Online, accessed May 2022

0 40 80 Feet
 0 10 20 Meters

1:1,000

Updated: 5/3/2022
 Project No. 70690

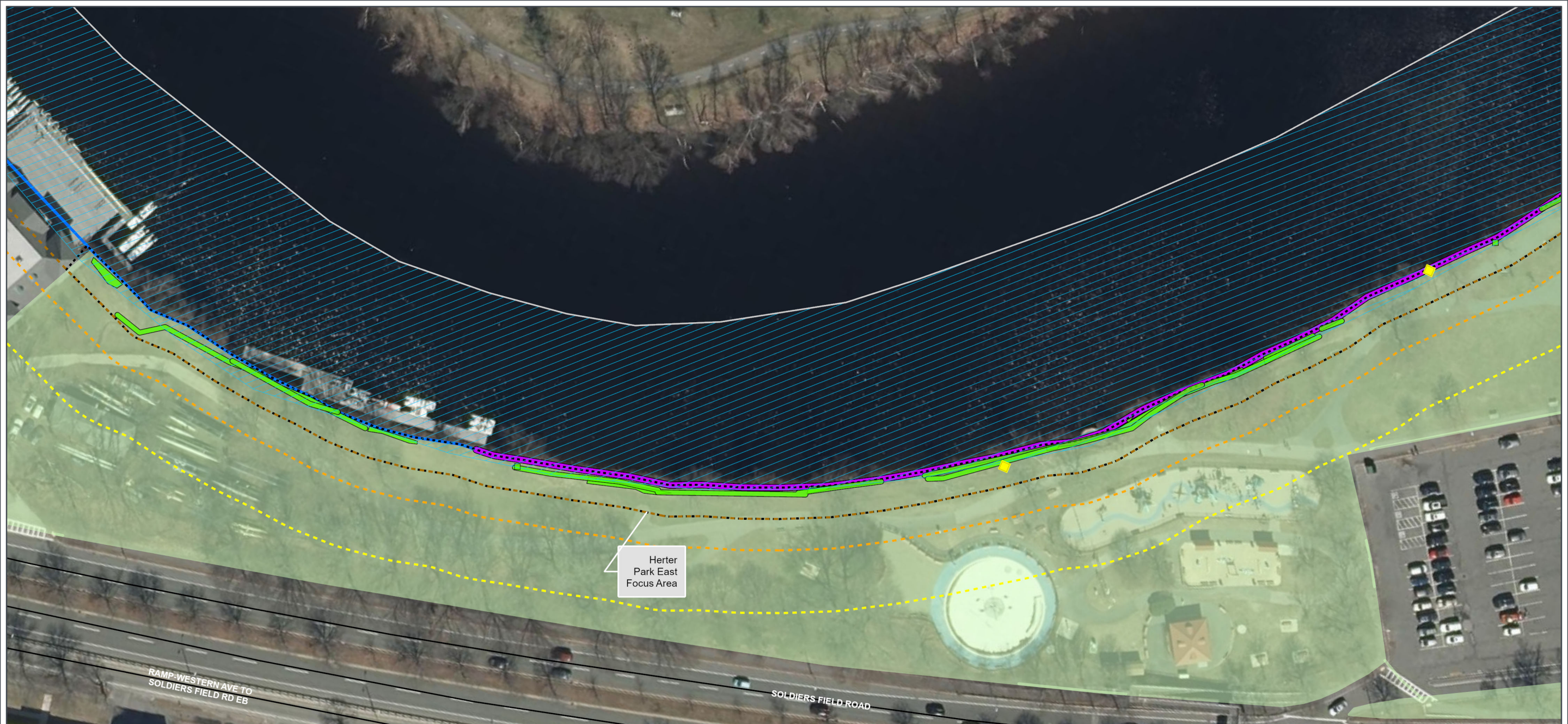

CHARLES RIVER VMP PERMITTING AND IMPLEMENTATION PROJECT
Figure 5. Wetland Resources and Invasive Plant Management Areas
 Map 4 of 7



- Boat Dock Area
- 25' Riverfront Area
- 100' Buffer Zone
- Delineated Bank
- Fourth of July Trimming Zone
- Head of Charles Trimming Zone
- Major Road
- Waterfront Area
- Invasive Plant Management Focus Area
- Invasive Plant Population
- Municipal Boundary
- Project Area
- Bordering Land Subject To Flooding
- Bordering Vegetated Wetland
- Isolated Vegetated Wetland

Boston, MA
 USGS 7.5' Quadrangles: Newton and Boston South
 NAD 1983 StatePlane Massachusetts Mainland FIPS 2001 Feet
 71.1392°W 42.3645°N



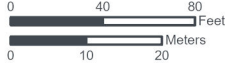

1:1,000



Base Map: ESRI ArcGIS Online, accessed May 2022
 Updated: 5/3/2022
 Project No. 70690



CHARLES RIVER VMP PERMITTING AND IMPLEMENTATION PROJECT
Figure 5. Wetland Resources and Invasive Plant Management Areas
 Map 5 of 7



- | | | |
|-------------------------------|--------------------------------------|------------------------------------|
| Boat Dock Area | Major Road | Bordering Land Subject To Flooding |
| 25' Riverfront Area | Waterfront Area | Delineated Wetland |
| 100' Buffer Zone | Invasive Plant Management Focus Area | Bordering Vegetated Wetland |
| Delineated Bank | Invasive Plant Population | Isolated Vegetated Wetland |
| Fourth of July Trimming Zone | Municipal Boundary | |
| Head of Charles Trimming Zone | Project Area | |

Boston, MA
 USGS 7.5' Quadrangles: Newton and Boston South
 NAD 1983 StatePlane Massachusetts Mainland FIPS 2001 Feet
 71.136°W 42.3664°N

1:1,000

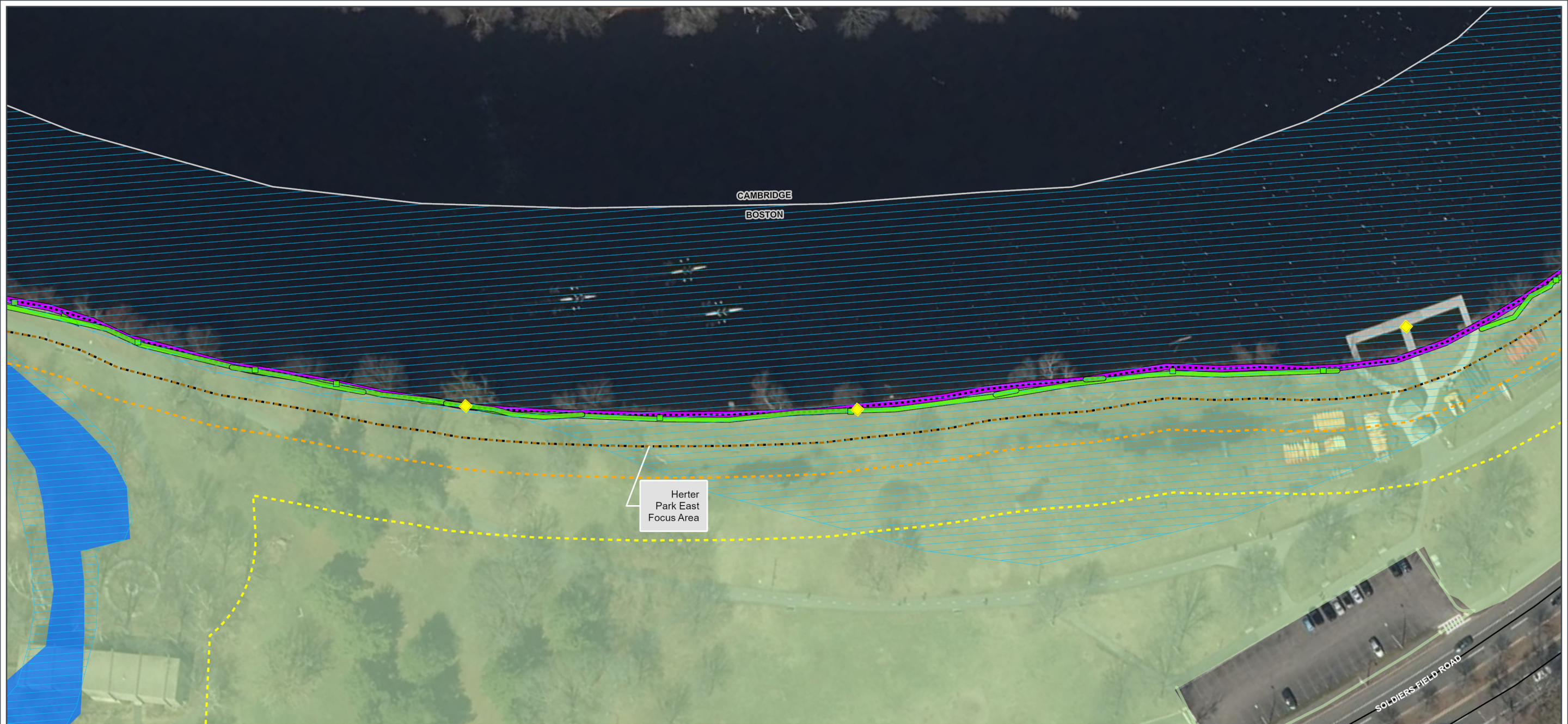

CHARLES RIVER VMP PERMITTING AND IMPLEMENTATION PROJECT
Figure 5. Wetland Resources and Invasive Plant Management Areas
 Map 6 of 7



- | | | |
|-------------------------------|--------------------------------------|------------------------------------|
| Boat Dock Area | Major Road | Bordering Land Subject To Flooding |
| 25' Riverfront Area | Waterfront Area | Delineated Wetland |
| 100' Buffer Zone | Invasive Plant Management Focus Area | Bordering Vegetated Wetland |
| Delineated Bank | Invasive Plant Population | Isolated Vegetated Wetland |
| Fourth of July Trimming Zone | Municipal Boundary | |
| Head of Charles Trimming Zone | Project Area | |

Boston, MA
 USGS 7.5' Quadrangles: Newton and Boston South
 NAD 1983 StatePlane Massachusetts Mainland FIPS 2001 Feet
 71.1327°W 42.3682°N

Base Map: ESRI ArcGIS Online, accessed May 2022

1:1,000

Updated: 5/3/2022
 Project No. 70690



CHARLES RIVER VMP PERMITTING AND IMPLEMENTATION PROJECT
Figure 5. Wetland Resources and Invasive Plant Management Areas
 Map 7 of 7



- | | | |
|-------------------------------|--------------------------------------|------------------------------------|
| Boat Dock Area | Major Road | Bordering Land Subject To Flooding |
| 25' Riverfront Area | Waterfront Area | Delineated Wetland |
| 100' Buffer Zone | Invasive Plant Management Focus Area | Bordering Vegetated Wetland |
| Delineated Bank | Invasive Plant Population | Isolated Vegetated Wetland |
| Fourth of July Trimming Zone | Municipal Boundary | |
| Head of Charles Trimming Zone | Project Area | |

Boston, MA
 USGS 7.5' Quadrangles: Newton and Boston South
 NAD 1983 StatePlane Massachusetts Mainland FIPS 2001 Feet
 71.1317°W 42.3707°N

1:1,000

Base Map: ESRI ArcGIS Online, accessed May 2022
 Updated: 5/3/2022
 Project No. 70690

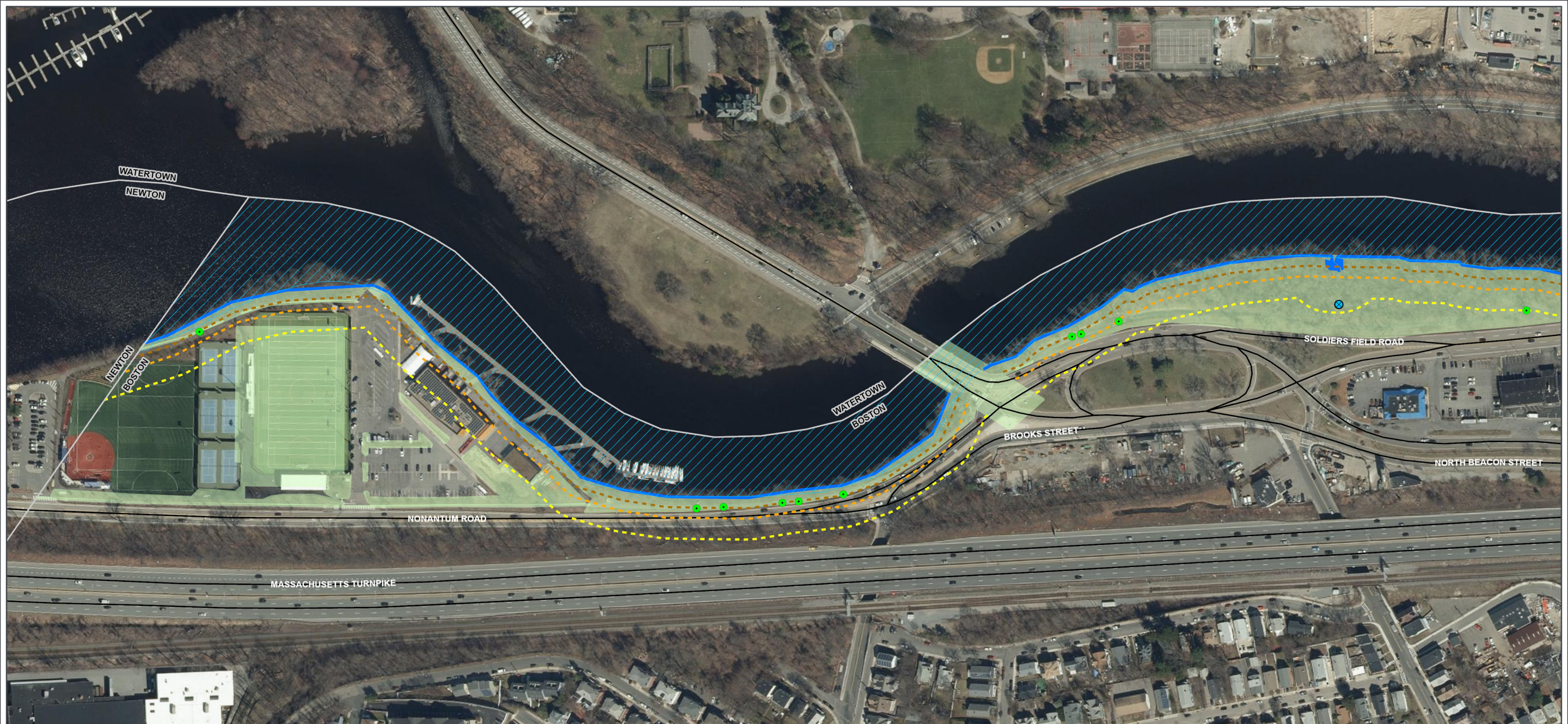

CHARLES RIVER VMP PERMITTING AND IMPLEMENTATION PROJECT
Figure 6. Wetland Resources and Tree Locations
 Map 1 of 11



- Tree
- Tree To Be Removed
- ⊗ Culvert
- 25' Riverfront Area
- 100' Buffer Zone
- Delineated Bank
- Major Road
- Waterfront Area
- Bordering Land Subject To Flooding
- Municipal Boundary
- Project Area
- Delineated Wetland**
- Bordering Vegetated Wetland
- Isolated Vegetated Wetland

Boston, MA
 USGS 7.5' Quadrangles: Newton and Boston South
 NAD 1983 StatePlane Massachusetts Mainland FIPS 2001 Feet
 71.1628°W 42.3589°N

0 120 240 Feet
 0 30 60 Meters

1:3,000

Base Map: ESRI ArcGIS Online, accessed May 2022

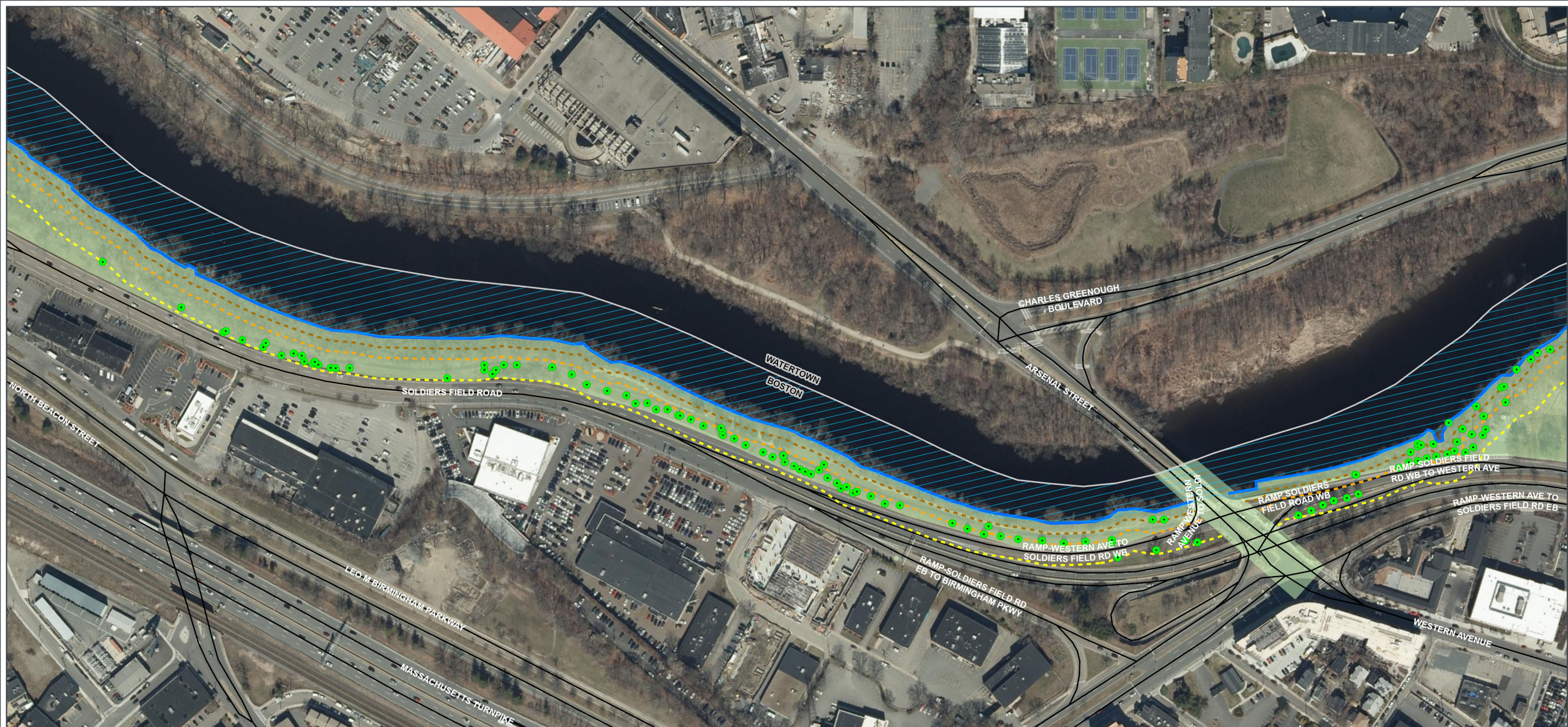

CHARLES RIVER VMP PERMITTING AND IMPLEMENTATION PROJECT
Figure 6. Wetland Resources and Tree Locations
 Map 2 of 11

- Tree
- Tree To Be Removed
- ⊗ Culvert
- 25' Riverfront Area
- 100' Buffer Zone
- Delineated Bank
- Major Road
- Waterfront Area
- Bordering Land Subject To Flooding
- Municipal Boundary
- Project Area
- Delineated Wetland**
- Bordering Vegetated Wetland
- Isolated Vegetated Wetland



Boston, MA
 USGS 7.5' Quadrangles: Newton and Boston South
 NAD 1983 StatePlane Massachusetts Mainland FIPS 2001 Feet
 71.1506°W 42.361°N

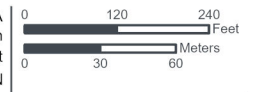
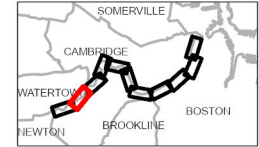

1:3,000

Base Map: ESRI ArcGIS Online, accessed May 2022

Updated: 5/4/2022
 Project No. 70690

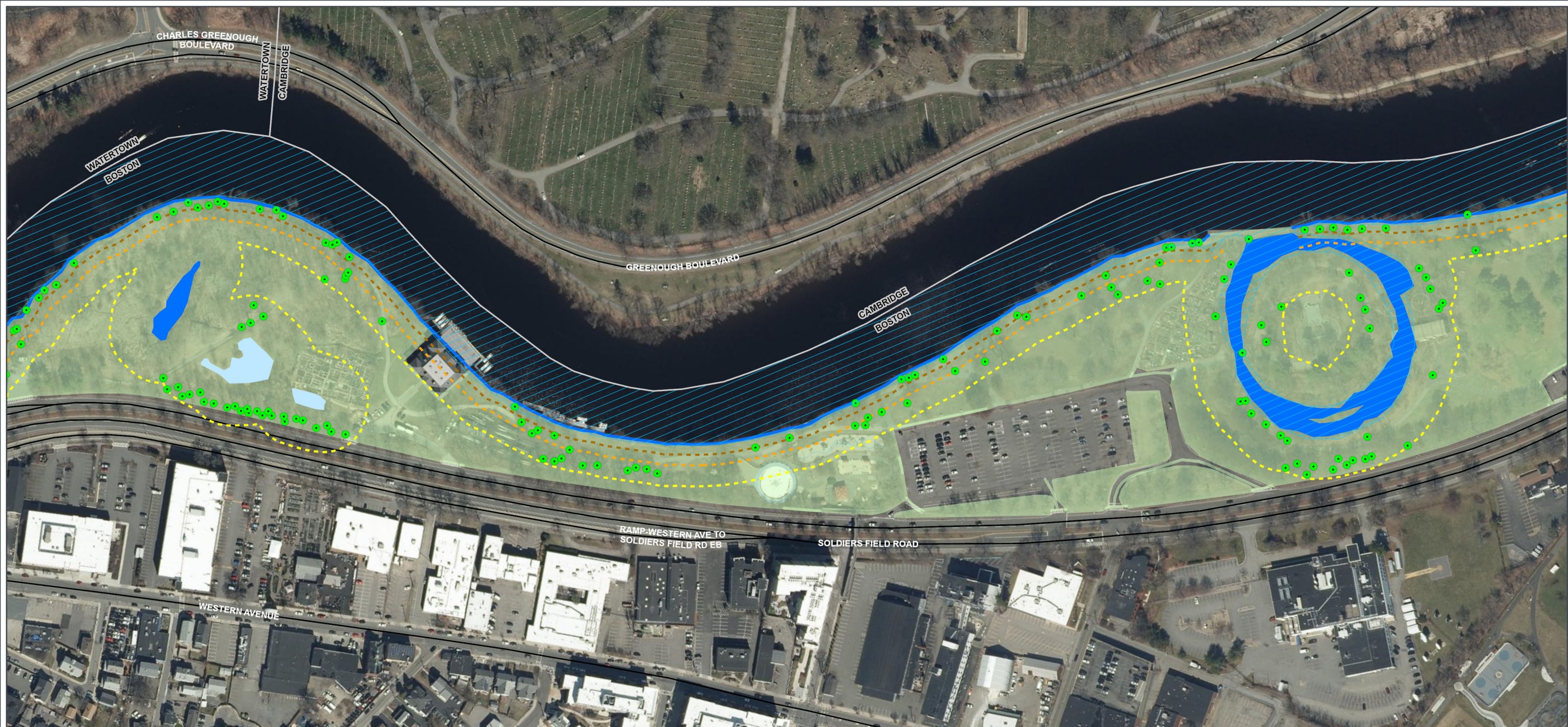

CHARLES RIVER VMP PERMITTING AND IMPLEMENTATION PROJECT
Figure 6. Wetland Resources and Tree Locations
 Map 3 of 11



- Tree
- Tree To Be Removed
- ⊗ Culvert
- 25' Riverfront Area
- 100' Buffer Zone
- Delineated Bank
- Major Road
- Waterfront Area
- Bordering Land Subject To Flooding
- Municipal Boundary
- Project Area
- Delineated Wetland**
- Bordering Vegetated Wetland
- Isolated Vegetated Wetland

Boston, MA
 USGS 7.5' Quadrangles: Newton and Boston South
 NAD 1983 StatePlane Massachusetts Mainland FIPS 2001 Feet
 71.1387°W 42.3649°N

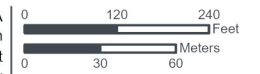
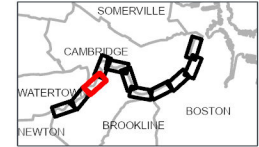

1:3,000

Base Map: ESRI ArcGIS Online, accessed May 2022

Updated: 5/4/2022
 Project No. 70690

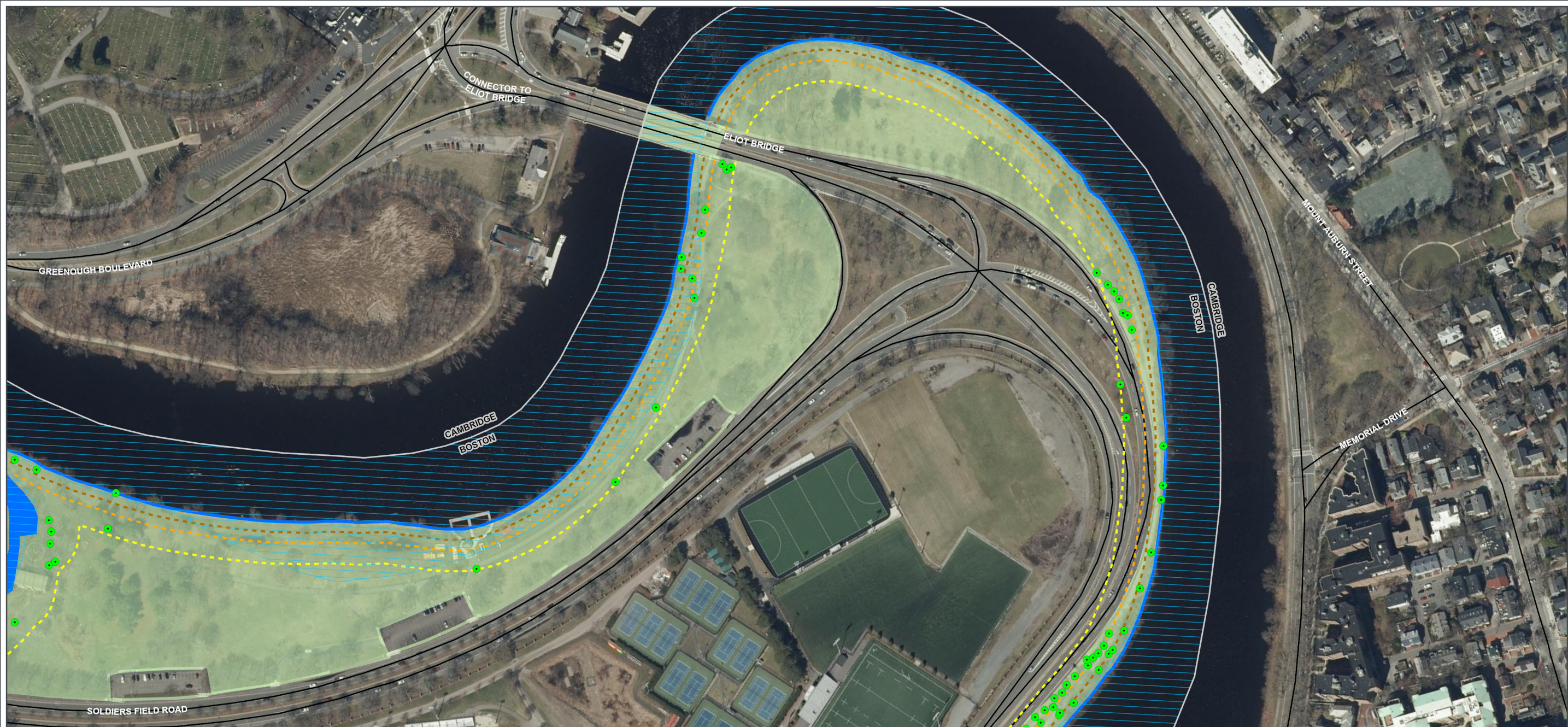

CHARLES RIVER VMP PERMITTING AND IMPLEMENTATION PROJECT
Figure 6. Wetland Resources and Tree Locations
 Map 4 of 11

- Tree
- Tree To Be Removed
- ⊗ Culvert
- 25' Riverfront Area
- 100' Buffer Zone
- Delineated Bank
- Major Road
- Waterfront Area
- Bordering Land Subject To Flooding
- Municipal Boundary
- Project Area
- Delineated Wetland**
- Bordering Vegetated Wetland
- Isolated Vegetated Wetland



Boston, MA
 USGS 7.5' Quadrangles: Newton and Boston South
 NAD 1983 StatePlane Massachusetts Mainland FIPS 2001 Feet
 71.1305°W 42.3713°N

1:3,000

Base Map: ESRI ArcGIS Online, accessed May 2022
 Updated: 5/4/2022
 Project No. 70690

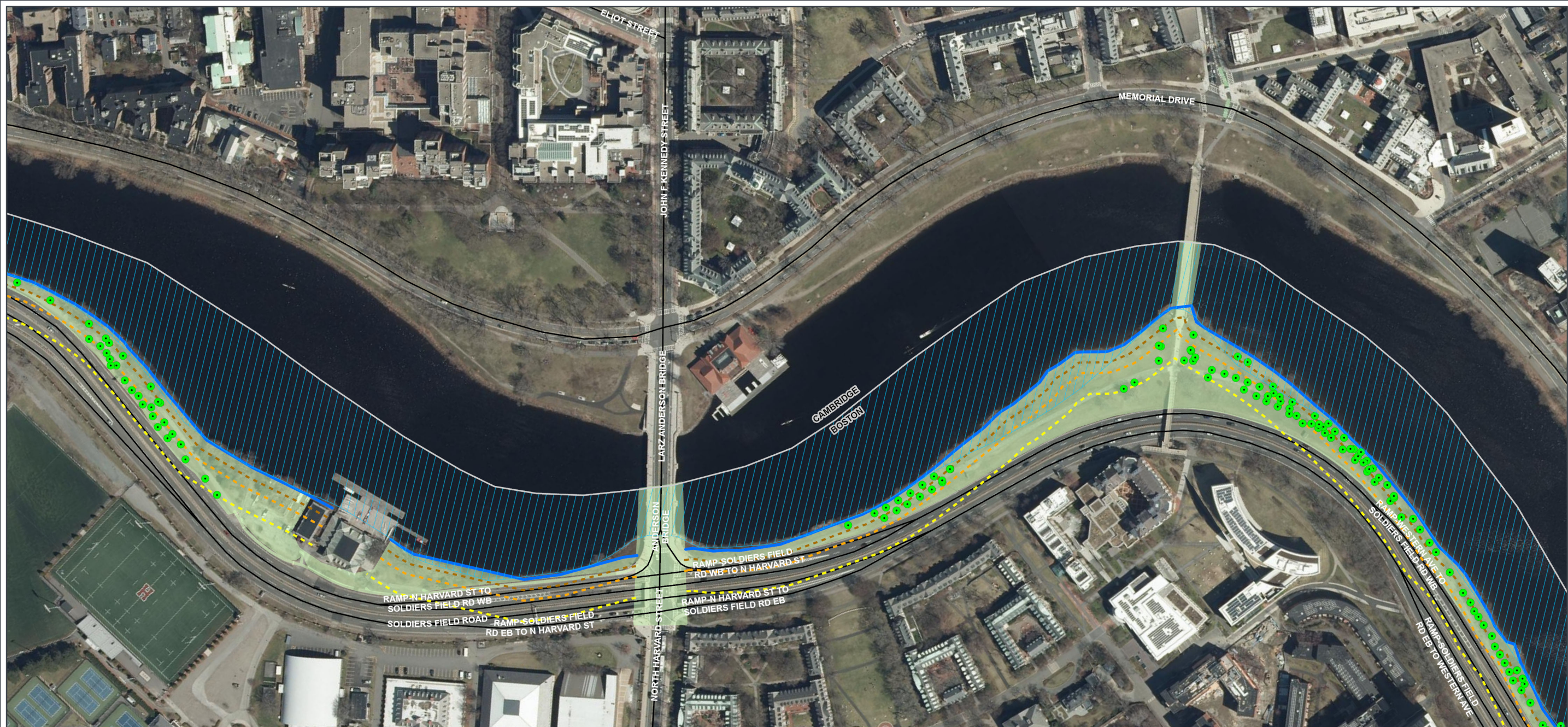

CHARLES RIVER VMP PERMITTING AND IMPLEMENTATION PROJECT
Figure 6. Wetland Resources and Tree Locations
 Map 5 of 11



- Tree
- Tree To Be Removed
- ⊗ Culvert
- 25' Riverfront Area
- 100' Buffer Zone
- Delineated Bank
- Major Road
- Waterfront Area
- Bordering Land Subject To Flooding
- Municipal Boundary
- Project Area
- Delineated Wetland**
- Bordering Vegetated Wetland
- Isolated Vegetated Wetland

Boston, MA
 USGS 7.5' Quadrangles: Newton and Boston South
 NAD 1983 StatePlane Massachusetts Mainland FIPS 2001 Feet
 71.1217°W 42.3692°N

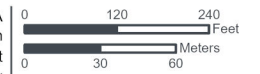
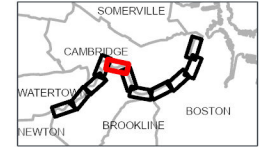

1:3,000

Base Map: ESRI ArcGIS Online, accessed May 2022

Updated: 5/4/2022
 Project No. 70690



CHARLES RIVER VMP PERMITTING AND IMPLEMENTATION PROJECT
Figure 6. Wetland Resources and Tree Locations
 Map 6 of 11

- Tree
- Tree To Be Removed
- ⊗ Culvert
- 25' Riverfront Area
- 100' Buffer Zone
- Delineated Bank
- Major Road
- Waterfront Area
- Bordering Land Subject To Flooding
- Municipal Boundary
- Project Area
- Delineated Wetland**
- Bordering Vegetated Wetland
- Isolated Vegetated Wetland

Boston, MA
 USGS 7.5' Quadrangles: Newton and Boston South
 NAD 1983 StatePlane Massachusetts Mainland FIPS 2001 Feet
 71.1174°W 42.3617°N

0 120 240 Feet

0 30 60 Meters

1:3,000

Base Map: ESRI ArcGIS Online, accessed May 2022
 Updated: 5/4/2022
 Project No. 70690

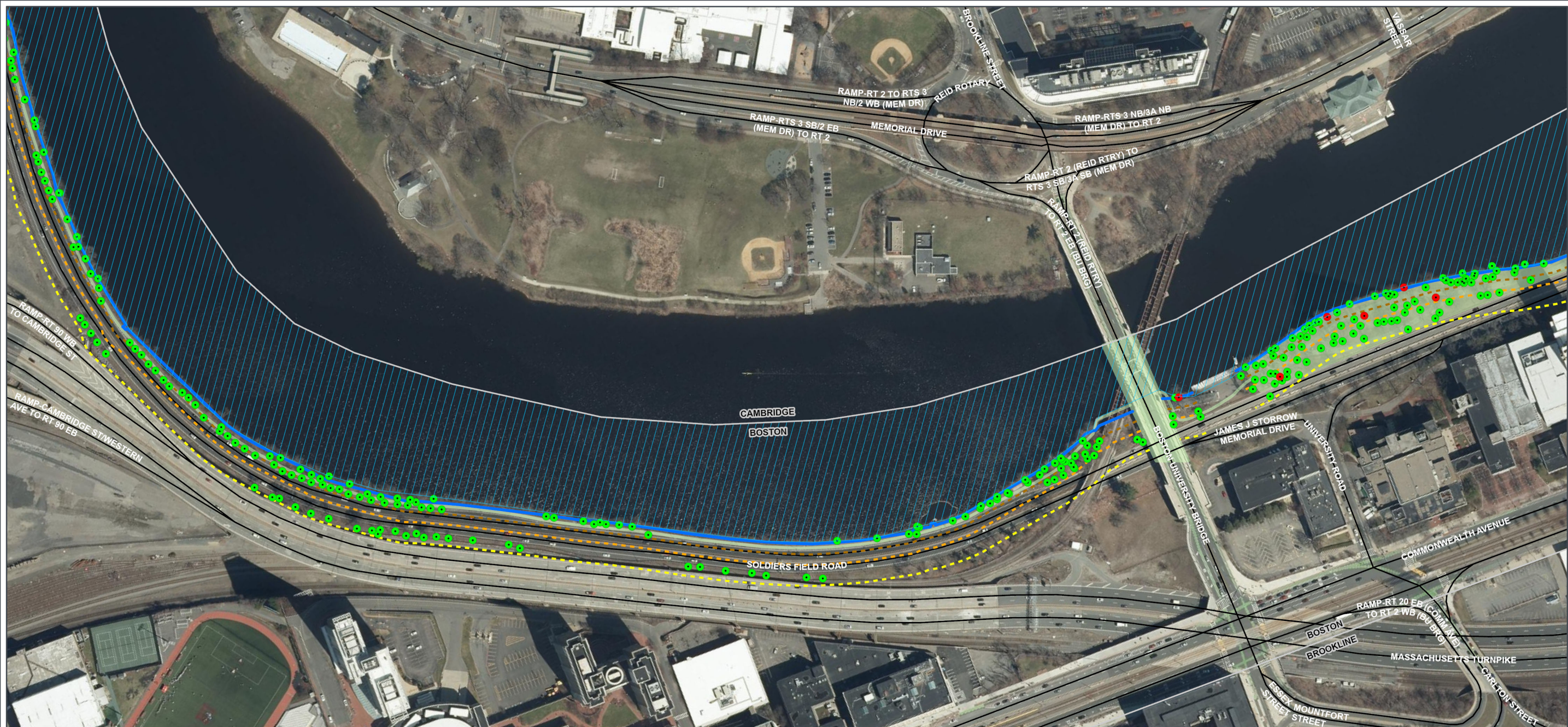

CHARLES RIVER VMP PERMITTING AND IMPLEMENTATION PROJECT
Figure 6. Wetland Resources and Tree Locations
 Map 7 of 11



- Tree
- Tree To Be Removed
- ⊗ Culvert
- 25' Riverfront Area
- 100' Buffer Zone
- Delineated Bank
- Major Road
- Waterfront Area
- Bordering Land Subject To Flooding
- Municipal Boundary
- Project Area
- Delineated Wetland**
- Bordering Vegetated Wetland
- Isolated Vegetated Wetland

Boston, MA
 USGS 7.5' Quadrangles: Newton and Boston South
 NAD 1983 StatePlane Massachusetts Mainland FIPS 2001 Feet
 71.1133°W 42.3535°N

1:3,000

Base Map: ESRI ArcGIS Online, accessed May 2022
 Updated: 5/4/2022
 Project No. 70690

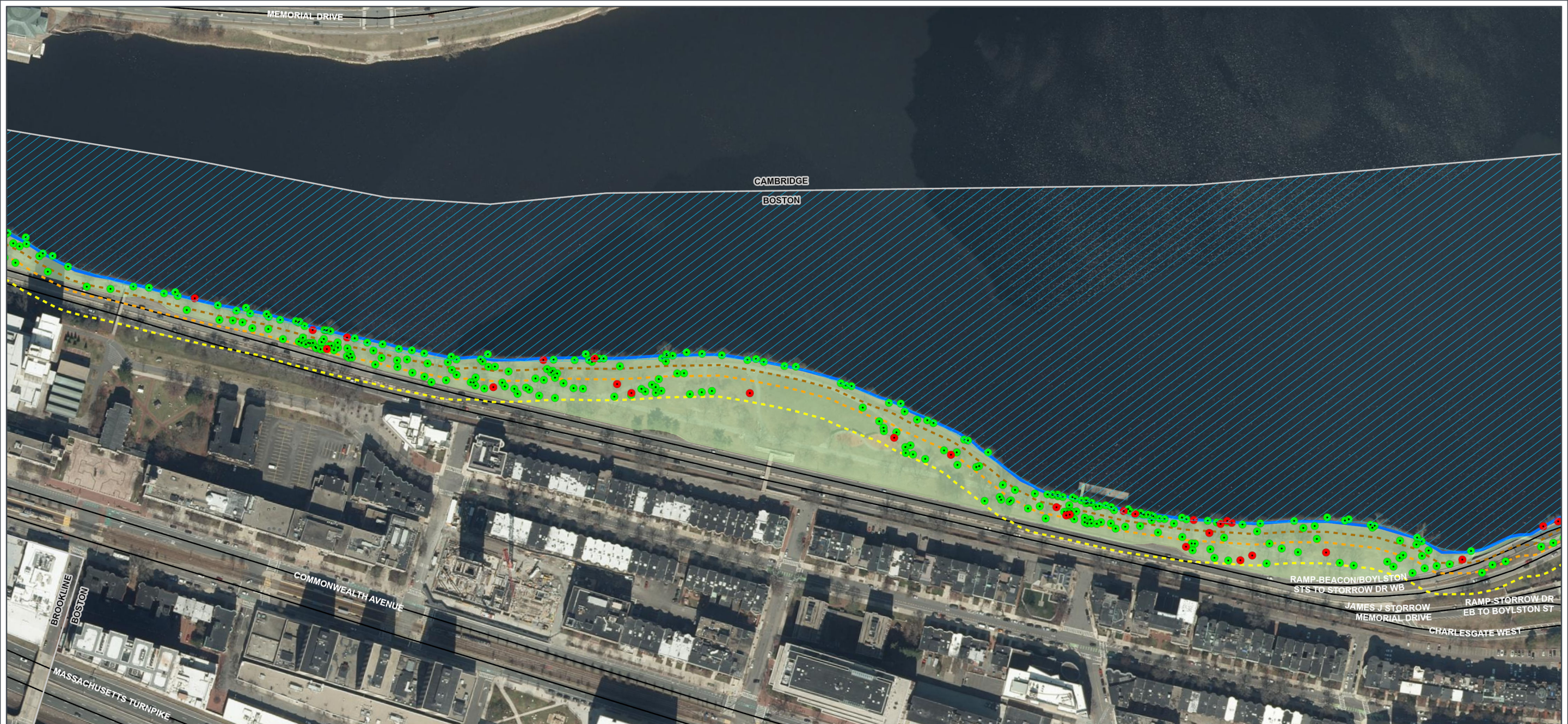

CHARLES RIVER VMP PERMITTING AND IMPLEMENTATION PROJECT
Figure 6. Wetland Resources and Tree Locations
 Map 8 of 11



- Tree
- Tree To Be Removed
- ⊗ Culvert
- 25' Riverfront Area
- 100' Buffer Zone
- Delineated Bank
- Major Road
- Waterfront Area
- Bordering Land Subject To Flooding
- Municipal Boundary
- Project Area
- Delineated Wetland**
- Bordering Vegetated Wetland
- Isolated Vegetated Wetland

Boston, MA
 USGS 7.5' Quadrangles: Newton and Boston South
 NAD 1983 StatePlane Massachusetts Mainland FIPS 2001 Feet
 71.1006°W 42.3517°N

Base Map: ESRI ArcGIS Online, accessed May 2022

0 120 240 Feet
 0 30 60 Meters
 1:3,000

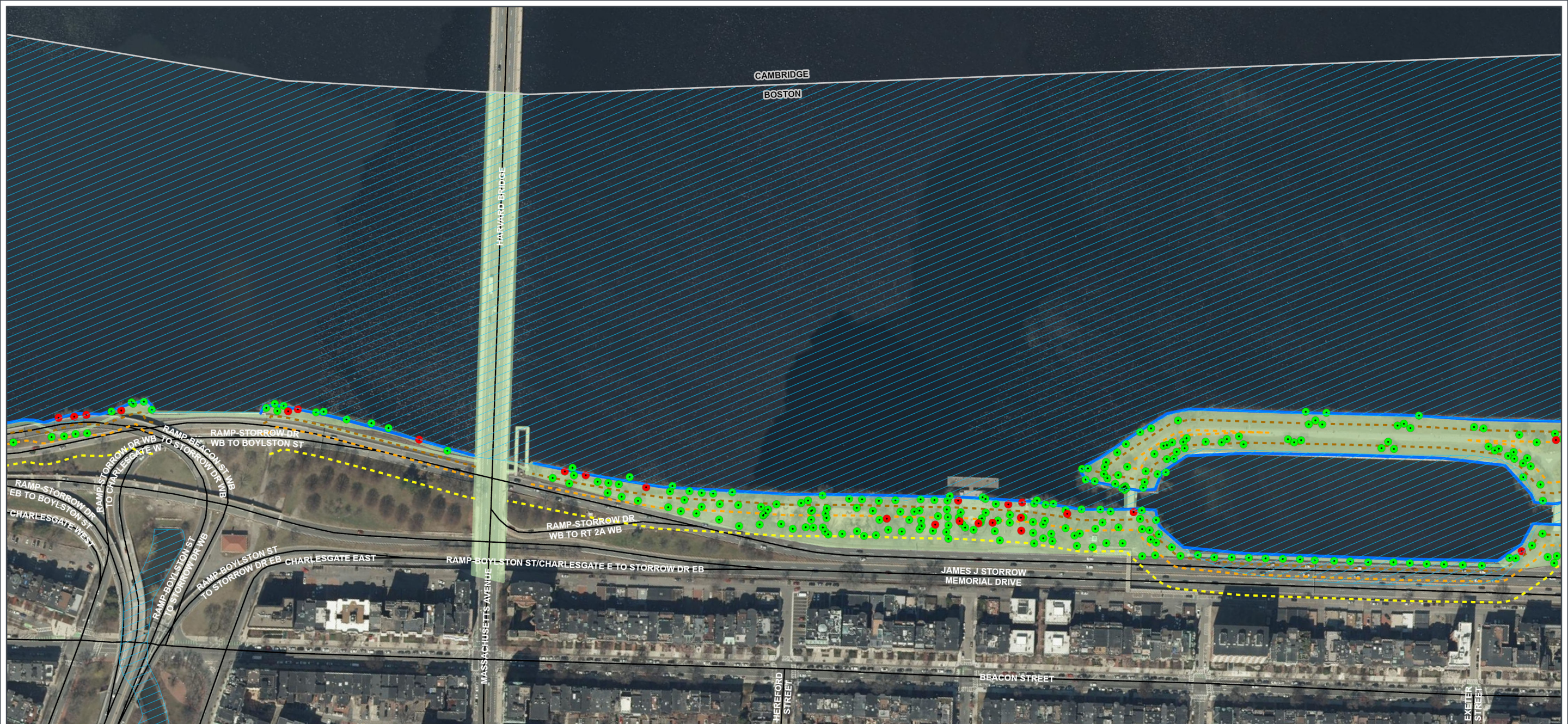

CHARLES RIVER VMP PERMITTING AND IMPLEMENTATION PROJECT
Figure 6. Wetland Resources and Tree Locations
 Map 9 of 11



- Tree
- Tree To Be Removed
- ⊗ Culvert
- 25' Riverfront Area
- 100' Buffer Zone
- Delineated Bank
- Major Road
- Waterfront Area
- Bordering Land Subject To Flooding
- Municipal Boundary
- Project Area
- Delineated Wetland**
- Bordering Vegetated Wetland
- Isolated Vegetated Wetland

Boston, MA
 USGS 7.5' Quadrangles: Newton and Boston South
 NAD 1983 StatePlane Massachusetts Mainland FIPS 2001 Feet
 71.088°W 42.3534°N

Base Map: ESRI ArcGIS Online, accessed May 2022

1:3,000

Updated: 5/4/2022
 Project No. 70690

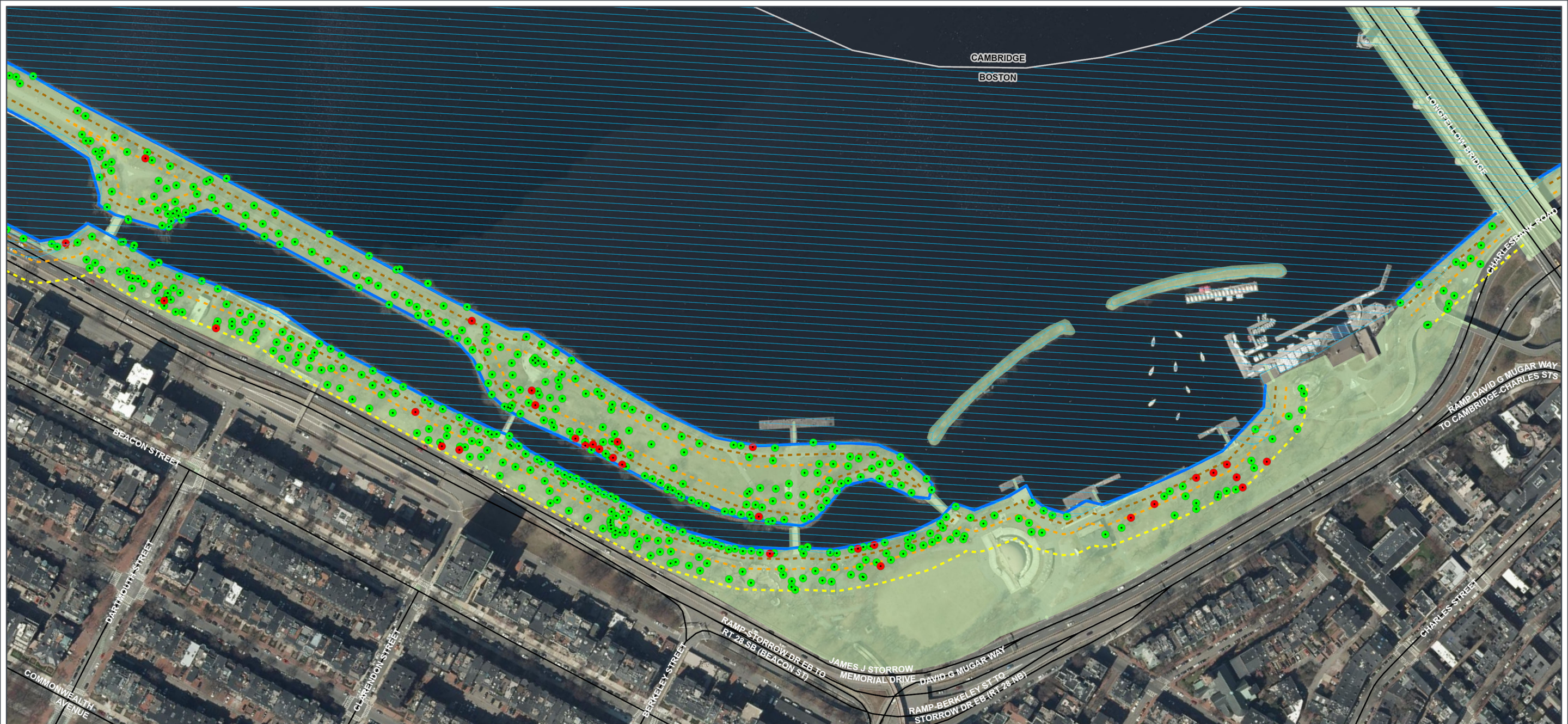

CHARLES RIVER VMP PERMITTING AND IMPLEMENTATION PROJECT
Figure 6. Wetland Resources and Tree Locations
 Map 10 of 11



- Tree
- Tree To Be Removed
- ⊗ Culvert
- 25' Riverfront Area
- 100' Buffer Zone
- Delineated Bank
- Major Road
- Waterfront Area
- Bordering Land Subject To Flooding
- Municipal Boundary
- Project Area
- Delineated Wetland**
- Bordering Vegetated Wetland
- Isolated Vegetated Wetland

Boston, MA
 USGS 7.5' Quadrangles: Newton and Boston South
 NAD 1983 StatePlane Massachusetts Mainland FIPS 2001 Feet
 71.0763°W 42.357°N

1:3,000

Base Map: ESRI ArcGIS Online, accessed May 2022

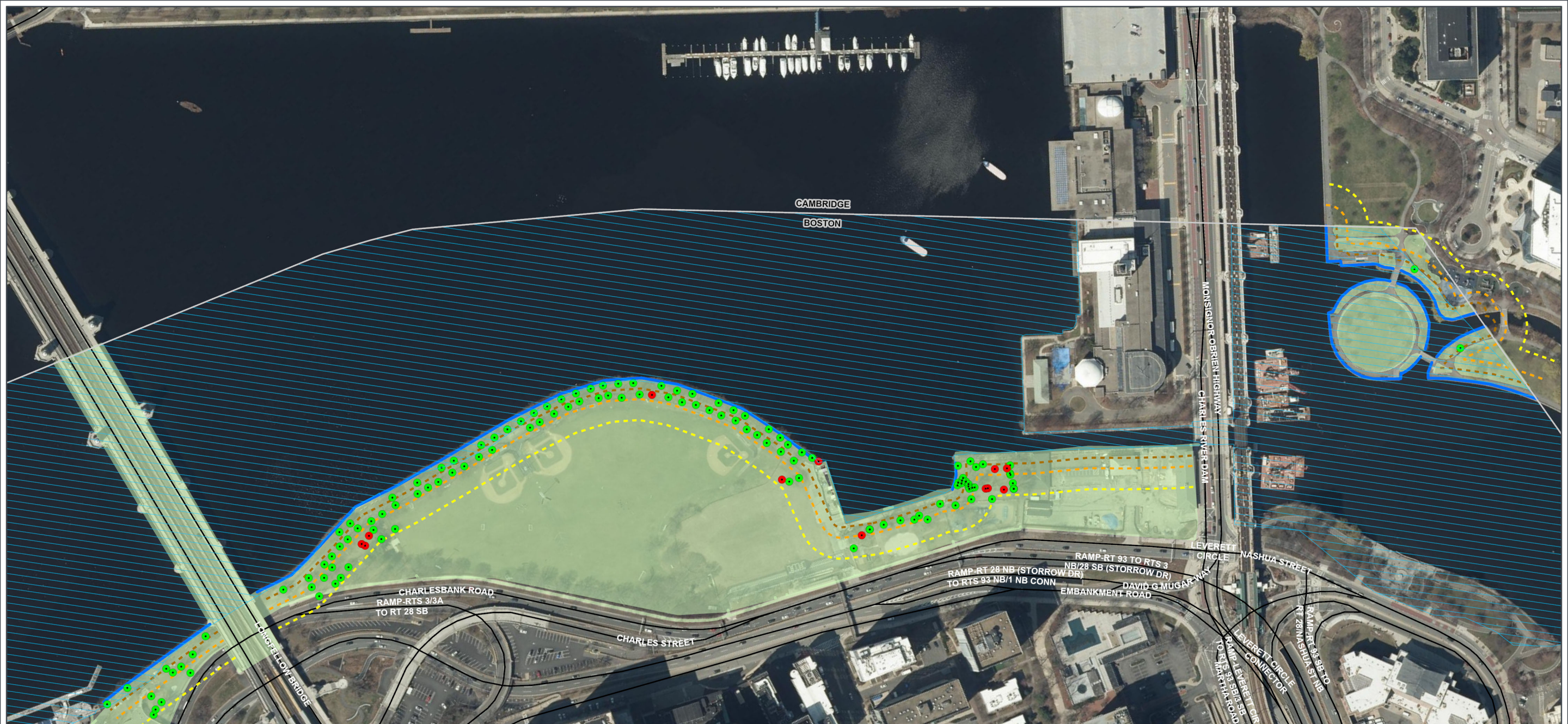

CHARLES RIVER VMP PERMITTING AND IMPLEMENTATION PROJECT
Figure 6. Wetland Resources and Tree Locations
 Map 11 of 11

- Tree
- Tree To Be Removed
- ⊗ Culvert
- 25' Riverfront Area
- 100' Buffer Zone
- Delineated Bank
- Major Road
- Waterfront Area
- Bordering Land Subject To Flooding
- Municipal Boundary
- Project Area
- Delineated Wetland**
- Bordering Vegetated Wetland
- Isolated Vegetated Wetland

Boston, MA
 USGS 7.5' Quadrangles: Newton and Boston South
 NAD 1983 StatePlane Massachusetts Mainland FIPS 2001 Feet
 71.0719°W 42.3652°N

Base Map: ESRI ArcGIS Online, accessed May 2022



0 120 240 Feet
 0 30 60 Meters

1:3,000

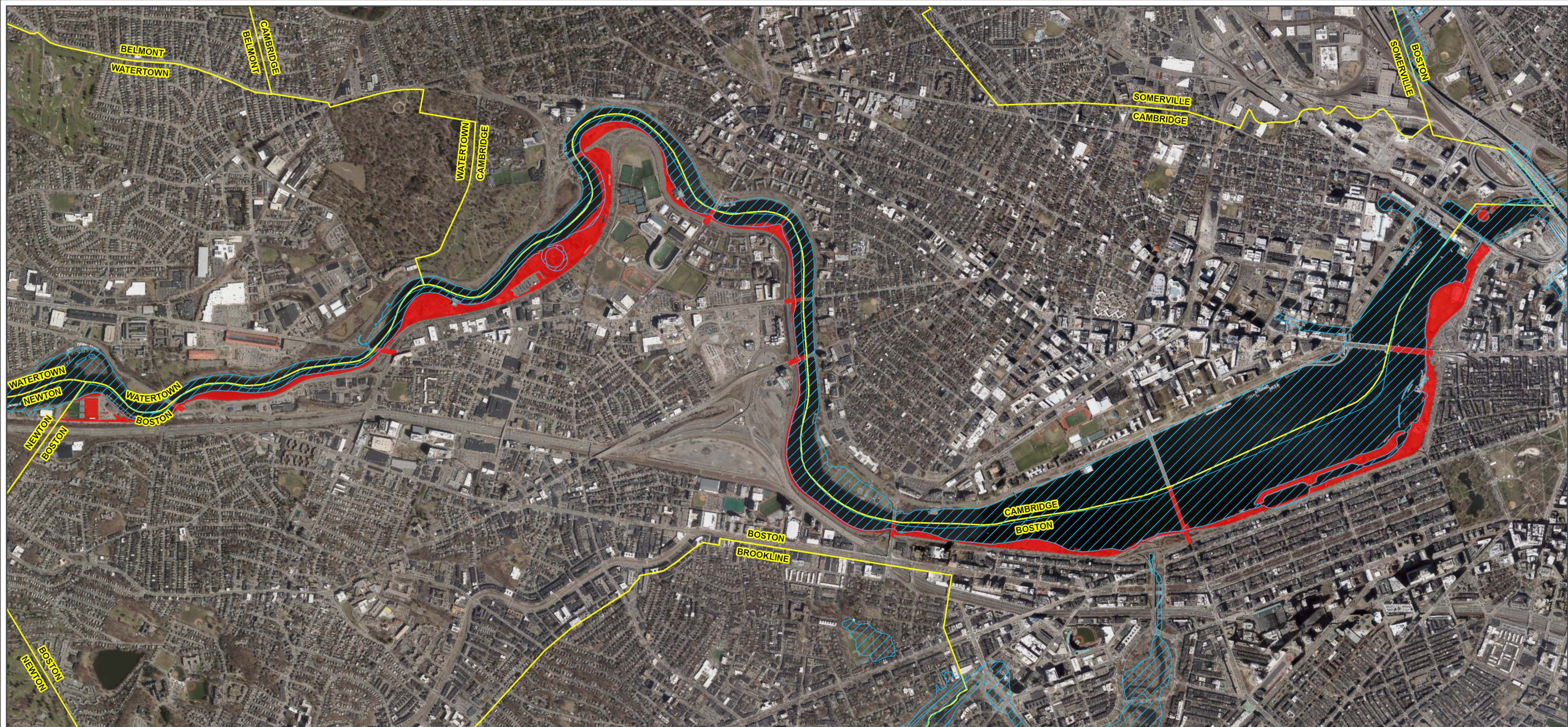
Updated: 5/4/2022
 Project No. 70690



CHARLES RIVER VMP PERMITTING AND IMPLEMENTATION PROJECT
Figure 7. 100-Year Flood Zone

-  100-Year Flood Zone
-  Municipal Boundary
-  Project Area



CHARLES RIVER VMP PERMITTING AND IMPLEMENTATION PROJECT
Figure 8. Bordering and Isolated Vegetated Wetlands
 Map 2 of 3



- Wetland Flag
- 25' Riverfront Area
- 100' Buffer Zone
- Delineated Bank
- Fourth of July Trimming Zone
- Head of Charles Trimming Zone
- Major Road
- Waterfront Area
- Bordering Land Subject To Flooding
- Municipal Boundary
- Project Area

- Delineated Wetland**
- Bordering Vegetated Wetland
 - Isolated Vegetated Wetland

Boston, MA
 USGS 7.5' Quadrangles: Newton and Boston South
 NAD 1983 StatePlane Massachusetts Mainland FIPS 2001 Feet
 71.1432°W 42.3637°N

0 20 40 Feet

0 10 20 Meters

1:1,000

Base Map: ESRI ArcGIS Online, accessed May 2022
 Updated: 5/4/2022
 Project No. 70690



CHARLES RIVER VMP PERMITTING AND IMPLEMENTATION PROJECT
Figure 8. Bordering and Isolated Vegetated Wetlands
 Map 3 of 3



- Wetland Flag
- 25' Riverfront Area
- 100' Buffer Zone
- Delineated Bank
- Fourth of July Trimming Zone
- Head of Charles Trimming Zone

- Major Road
- Waterfront Area
- Bordering Land Subject To Flooding
- Municipal Boundary
- Project Area

- Delineated Wetland**
- Bordering Vegetated Wetland
 - Isolated Vegetated Wetland

Boston, MA
 USGS 7.5' Quadrangles: Newton and Boston South
 NAD 1983 StatePlane Massachusetts Mainland FIPS 2001 Feet
 71.1344°W 42.3664°N

Base Map: ESRI ArcGIS Online, accessed May 2022
 Updated: 5/4/2022
 Project No. 70690

APPENDIX D

Site Photographs



Photograph 1. Daly Field and Tennis Courts — Southwestern end of focus area, facing NE (1/13/2022)



Photograph 2. Daly Field and Tennis Courts — Middle of focus area, facing NE (1/13/2022)



Photograph 3. Daly Field and Tennis Courts — Northeastern end of focus area, facing SW (1/13/2022)



Photograph 4. Daly Field and Tennis Courts — Northeastern end of focus area, facing N (1/13/2022)



Photograph 5. Dr. Paul Dudley White Bike Path — Western end of focus area, facing E (1/21/2022)



Photograph 6. Dr. Paul Dudley White Bike Path — Middle of focus area, facing E (1/21/2022)



Photograph 7. Dr. Paul Dudley White Bike Path — Middle of focus area, facing W (1/21/2022)



Photograph 8. Dr. Paul Dudley White Bike Path — Northeastern end of focus area, facing SW (1/21/2022)



Photograph 9. Herter Park West — Northwestern corner of focus area, facing NE



Photograph 10. Herter Park West — Southern middle of focus area, facing NE (1/13/2022)



Photograph 11. Herter Park West — Southern middle of focus area, facing SW



Photograph 12. Herter Park West— Northeastern corner of focus area, facing SW



Photograph 13. Herter Park East — Southern end of focus area, facing E (1/20/2022)



Photograph 14. Herter Park East — Southern middle of focus area, facing SW (1/20/2022)



Photograph 15. Herter Park East — Southern middle of focus area facing NE (1/20/2022)



Photograph 16. Herter Park East — Northern middle of focus area facing S (1/20/2022)



Photograph 17. Herter Park East — Northern middle of focus area facing N (1/20/2022)



Photograph 18. Herter Park East — Northern end of focus area, facing S (1/20/2022)

APPENDIX E

Restoration and Landscape Type Specifications

1 LANDSCAPE TYPE DESCRIPTIONS

1.1 Lawn (L)

DCR and the Esplanade Association actively mow lawns to provide safe recreational resources to the public. Lawns are typically mowed to keep a lead blade height of 4 inches. Lawns are mown when the ground is dry to prevent any rutting from the equipment. In general, mowing is avoided in close proximity to trees, shrubs, and plantings. When necessary, lawns are restored by top dressing with compost or clean soil and overseeding with a DCR approved seed mix (Appendix E).

1.2 Meadow (M)

DCR encourages the installation of low managed meadows whenever possible. Established wildflower or grassland meadows don't require additional watering during the dry season and provide habitat for insect and wildlife. DCR manages meadows by mowing them once a year either in the early Spring or late Fall. Cut vegetation is left on site as a seed source.

1.3 River's Edge (RE)

Vegetation and tree branches are trimmed along the River's edge to provide a access to views of the River. This type of management is primarily performed prior to the special events included in this filing. However, when staff is available, DCR staff may perform the same "special events trimming" in areas that are not the focus of the special events, particularly across from benches and at established overlooks and vistas. Tree management other than branch pruning shall be completed in accordance with Section 2 below.

1.4 Woodland (T)

Vegetation, including tree pruning, is managed using mechanical means including mowers, weedwhackers, and chainsaws. Tree removal is completed on an as needed basis based on the DCR Arborist review. In the future, tree removal will be completed following the guidelines highlighted in Section 2. Lawn maintenance, where present, is maintained using a combination of both Lawn and Meadow techniques.

Pruning of trees can be performed to enhance the overall appearance of the specimen or to remove specific defects or hazards such as declining or dead branches. Vista pruning may be utilized to open viewsheds in specific locations. In all cases, the species of the tree must be identified before pruning to determine best practices for that particular plant.

Pruning should enhance the natural growth habit of the species, except when specific ornamental goals (such as topiary, pollarding, and espalier) are desired. These specialty techniques are not currently utilized in the study area; rather, pruning will be performed to remove dead, broken, crossing, and interfering limbs. The canopy of the tree may be selectively thinned to promote air circulation and reduce the occurrence of fungal issues depending on the species (ISA, 2018).

Broken, dead, or diseased branches can be removed at any time of the year, especially if the branches pose a hazard to passing pedestrians, bicyclists, or motorists. Most deciduous species can be pruned

during the late fall and winter when the plant is dormant. Coniferous species should be pruned in the late winter before emergent growth. Pruning in winter reduces the risk of pests and disease and gives the plant time to compartmentalize the injury (ISA, 2018).

Tree pruning should be performed by a qualified professional, and maintenance staff should be trained to remove hazard branches correctly to prevent damage and the risk of pests and diseases. Pruning techniques may be necessary and are dependent on the species, location, and condition of the plant (University of Delaware, 2018).

1.5 Green Infrastructure (GI)

Green infrastructure vegetation will be managed in accordance with the infrastructure Operations and Maintenance Plan. Management will include cutting, weeding, replanting or reseeding.

1.6 Landscaped Areas (LA)

Typical maintenance activities include raking, weeding, clearing fallen branches, removal of dead plant material and shrub pruning. Planted beds and community gardens are generally maintained by DCR partners and lessees. DCR landscaped areas are replanted and reseeded on an “as needed” basis. Future DCR plantings will be selected from the restoration planting list (Attachment E). DCR will encourage partners and lessees to select plantings from DCR’s planting list.

1.7 Circulation (C)

Vegetation, including tree branches, encroaching on public parkways, sidewalks, paths, bridges and trails creates unfavorable conditions for the general public. Hazards include but are not limited to, blocking access, obscuring signage or guard rails, limiting sight line, drainage restrictions and the deterioration of road or trail beds. In an effort to protect the trail corridor, DCR maintains a ±5-foot-strip of mowed lawn along each side of these facilities. Similarly, DCR manages woody vegetation and vines within a ±10 foot area adjacent to all bridges and ramps, unless purposefully landscaped (e.g., Weeks Bridge). Vegetation is managed using mechanical means including mowers, weedwhackers and chainsaws. Tree removal is completed on an as needed basis based on the DCR Arborist review. In the future, tree removal will be completed following the guidelines highlighted in Section 2.

1.8 Structures (S)

Removing unwanted vegetation, including trees, from buildings extends to a combination of aesthetic and safety reasons. Although weeds can be considered simple eyesores, they can cause many problems that extend beyond aesthetic concerns. Removing vegetation from around the edges of buildings reduces the risk of injury due to unseen hazards. It also makes maintenance easier and can help improve visibility for security efforts. As part of routine structure maintenance, DCR clears brush, ground cover, vines, trees and weeds from a ten-foot perimeter around DCR managed facilities. Tree removal is completed on an as needed basis based on the DCR Arborist review. In the future, tree removal will be completed following the guidelines highlighted in Section 2.

Management is completed by both manual and mechanical means.

2 TREE INVENTORY DETAILS

Currently, DCR completes tree removal on an as needed basis and based on recommendations by the DCR arborist. For future tree removal, however, DCR will initiate a comprehensive inventory of the trees of the Lower Basin. Some of this work has been done by partners including the Esplanade Association as recently as 2015 and DCR will plan to integrate this data with new inventory data that is to be collected. This basic tree inventory and visual inspection will include a report stating tree risk potential, and recommendations for mitigating the risks associated with certain trees. Such recommendations may include the need for a more in-depth evaluation, structural inspection of the tree trunk, further inspection of roots/ root flare, aerial inspection of the tree, pruning, installation of structural support systems, installation of lightning protection systems, soil management, pest management, or the need for tree removal. All inventory work will be completed by or under the guidance and review of a certified arborist.

Tree Inventory Specifications and Deliverables

Inventory all landscape or intentionally planted trees greater than 2-inch diameter at 4.5 feet above the ground (i.e., diameter at breast height [DBH]) and inventory all naturally occurring trees of 6 inches DBH.

Attributes collected for each tree include the following:

- Tree Botanical Name and Common Name
- Tree Identification Number
- DBH
- Condition Class (Good, Fair, Poor or Dead)
- Age Class (New planting, Young, Semi-mature, Mature, Over-mature)
- Height Class (Large, Medium, Small)
- Estimated canopy radius (± 5 ft.)
- Root Zone Infringement (<25%, 25-50%, 51-75%, >75%)
- Tree Work Recommendations such as: Crown cleaning, Crown thinning, Crown raising, Crown reduction, Structural pruning, Tree removal, Cabling or brace rod installation, Lightning protection system installation
- Tree Defects such as: dead and broken, hanging branches; poorly attached branches and stems such as co-dominant stems; poor architecture; cracks in stems and scaffold limbs; cankers and significant bark injuries in stems and scaffold limbs; Wood decay in stems and scaffold limbs; root related defects including decayed, buried root flares, obvious soil disturbance within the critical root zone
- Observed Pests/Diseases
- International Society of Arboriculture (ISA) level II Basic Tree Risk Assessment

Trees will be visually assessed following the ISA Best Management Practices (BMPs) for Tree Risk Assessment and/or applicable industry standards. The likelihood of failure, likelihood of impacting a target, and consequences of failure will be rated in the field to determine the overall risk rating. The overall risk rating assigned to the inventoried tree will correspond to the highest risk rating associated

with the inventoried tree. This rating scale will serve to help the Owner or tree manager prioritize and schedule remedial treatments.

Failure, potential and risk cannot always be assessed by visual inspection from the ground. For some trees, more detailed analyses of decay and defects may be required. Where flare roots cannot be inspected due to soil and/or mulch covering the root flare, excavation will be recommended prior to providing a risk rating. A climbing inspection may be required to assess defects that are present in the upper crown. Climbing inspections, decay/defect, and root collar excavation will be undertaken as needed.

Management Actions Based on the Inventory

DCR will use the data from the tree inventory to implement a pro-active management plan for the trees of the Lower Basin. As mentioned above, the primary principle guiding actions prescribed in this plan will be safety and a focus on reducing tree risk. However, the inventory will provide valuable data that will be used to guide decisions about canopy restoration and tree planting opportunities that will help maintain ecological health and enhance visitor experiences in the park.

DCR will take steps to mitigate the risk from trees that are rated as Severe and High Risk. While it is true that mitigating for risk often improves the collective condition of a tree population, it is important to recognize that tree condition does not correlate directly with tree risk. Responsible management requires that DCR focus its actions on addressing risk as a first priority. Tree risk may come equally from defects that affect significant tree parts or whole trees and the management actions taken will address these defects accordingly with risk mitigation that is appropriate. In many cases, trees will be maintained after removal of defective parts but whole tree removal will often be required. DCR will prepare an annual schedule of work to prioritize addressing the highest risk trees first and proceeding down the rating scale recognizing that work will be constrained by available budgets and staff management capacity. It is unlikely that all of the higher risk trees will be mitigated in any one fiscal year without significant commitment of resources that are beyond the control of the agency.

Once the trees have been prioritized based upon their risk rating, DCR will begin mitigation work including the removal of whole trees where necessary. DCR will provide the comprehensive list of high-risk trees and the work plan to mitigate the trees to local conservation commissions as part of the process of beginning work. All tree work will be done according to ISA BMPs and employing measures to protect resource areas from impact.

It is hoped that this first comprehensive inventory and risk management effort will establish a base population of trees in the basin that are safe and in collectively better condition than presently exists. However, DCR recognizes that trees are dynamic, living organisms that change over time. This will require the agency to conduct periodic risk assessments to mitigate the trees that decline over time or are damaged by weather and other events. DCR proposes a seven year period for the interval between comprehensive risk assessments. This period is selected to avoid possible over management of the trees that may result from a shorter period and conversely inadequate risk mitigation that could result if the period is longer. DCR will plan to follow the same protocol with each risk assessment (following industry standard BMPs) and will take action to mitigate risk trees identified by each assessment. DCR will provide risk assessment data to local conservation commissions as part of the work flow process each time the assessment is done and mitigation work commences. In addition to the tree work done in response to the risk assessments, DCR will continue to address tree risk on an as needed basis when high risk tree defects are identified outside of the formal assessment.

2.1 Partner-Assisted Invasive Plant Removal/Maintenance

In addition to special invasive plant management projects, DCR also partners with organizations to conduct maintenance invasive plant management. Partners include The Charles River Conservancy (CRC) and the Charles River Watershed Association (CRWA). Routine invasive plant management conducted by these two partner organizations include the following management approaches.

- Woody vegetation manual management
 - Stem thickness less than 1 inch: pull EXCEPT along the bank
 - Stem thickness more than 1 inch: cut or weed wrench
 - Do not pull vine from a tree.
 - Do not weed wrench on bank
- Species-specific management
 - Asiatic bittersweet (*Celastrus orbiculatus*): Cutting and pulling
 - Garlic mustard (*Alliaria petiolata*): hand-pulling
 - Swallow wort (*Cynanthcum* spp.) species: Cutting and hand pulling/seed pod removal
 - Buckthorn (*Rhamnus* spp.) species: Weed wrenching and hand pulling

All cut or pulled woody material will be disposed of on site and left as habitat piles. All fruit and/or seed shall be removed before piling. All piles will be located at least 10 feet from a trail, path, and wetland. Seeds, fruit, and garlic mustard will be bagged and removed from the site and disposed of off-site.

Additional invasive plants may be authorized for removal by DCR. Removal will be completed using the management techniques described above. This work will happen under a MOU or Volunteer Stewardship Agreement with DCR, specifically at Herter Park.

LANDSCAPE RESTORATION PLANT LISTS

The following plant lists have been developed for the Department of Conservation and Recreation (DCR) Charles River Basin Riverbank Vegetation Management Plan. Deviations from this plant and seed list should be approved by DCR's Landscape Architects and/or Ecologist. Any additions or modifications shall be presented to the Conservation Commission for review and authorization prior to implementation.

As defined by BioMap 2 and 'The Vascular Plants of Massachusetts' handbook, plants native to the Boston Basin shall be given priority selection. Plants native to Southern New England Coastal Plains and Hills may follow as secondary preference.¹

Lawn—

Low-Mow Grass Seed Mixes

The following low-mow grass seed mixes (or equal substitutions) are recommended to be utilized for overseeding passive recreation areas that need to stay at a low height. Mix shall be selected from those included below by required site conditions

- Natural Perfection Mix, by Lavoie Horticulture- A low-mow mix that includes native fescues intended to be mowed 1x per year after seed establishment, with no requirement for fertilizer or water after establishment.
- Fleur De Lawn (PT 755)- Developed by Oregon State University, a mix of low-growing flowers, clovers and grasses. The clovers naturally self-feed the lawn with nitrogen and the low growing flowers provide pollinator habitat. Maintain as high as 5" for a mini-meadow look, or 3" for a more manicured lawn.
- ["Dog Park Eco-Lawn Mix"](#) - Tall fescue provides high salt tolerance and rhizomatous 'self-repairing' growth patterns to counter effects of pet urine. Naturally nitrogen-fixing clover and a bit of vigorous perennial ryegrass round out the mix. Wear and drought-tolerant. Dappled shade to full sun. A great choice for any high traffic area where drought tolerance and Rhizomatous Tall Fescue attributes are desired. Mow about once a month to maintain between 3 and 5 inches.
- [Eco-Turf Mix](#): Tolerant grasses and Microclover® holds up well to wear—for high traffic areas. Low maintenance and low input, more shade tolerant than many other lawn alternatives. Once established this mix requires little supplemental irrigation or fertilizer and tolerates acidic and shady sites. Microclover feeds the companion grasses with nitrogen. The extremely drought-tolerant Microclover maintains a nice dark green color once established and should not require irrigation in most climates. Its inclusion with the grasses allows the soil to retain more moisture in dry periods which sustains an overall green appearance of grass through the summer. Mow about once a month to maintain this lawn at a height between 2 and 5 inches.
- [Verdant Lawn](#): Richly vegetative, this lawn is multi-textured with Microclover and white yarrow to enhance wear tolerance and provide year-round green cover. Performs well in both sun and shade. Diversity without flowers.
- [VT Wildflower Farm – No Mow Mix](#) Blend of low-mow grasses, Festuca rubra (Creeping Red Fescue), Festuca brevipila 'Charlot' (Hard Fescue 'Charlot'), Festuca ovina var. duriuscula 'Heron (Hard Fescue 'Heron').

¹Natural Heritage & Endangered Species Program of the Massachusetts Division of Fisheries & Wildlife. (2011). *BioMap2 Technical Report - Building a Better BioMap*. Boston: Massachusetts Department of Fish & Game.

- [VT Wildflower Farm- Eco Lawn](#) Salt tolerant blend of fine fescue grasses that create a somewhat clumping appearance: Shoreline Creeping Red Fescue, Class One Creeping Red Fescue, SR3150 Hard Fescue, Quatro Sheep Fescue, Carson Chewings Fescue
- [American Meadows – Low Mow](#) - This cool season grass mix contains 6 different fescues - Jamestown Chewing, Quatro Sheep, Sea Link Slender, Sword, Aurora and Kent Creeping. Mixture of low-growing, fine-textured turf grasses, mixture only requires mowing every four to six weeks. All six grass varieties are also drought-resistant and withstand most growing conditions.
- [American Meadows – Creeping Red Fescue](#) or [Ernst Seeds – Festuca rubra ‘Pennlawn’](#) - low-maintenance grass ground cover. It is beneficial for erosion control and will attract wildlife. Single variety, less resilient if seed doesn't take.

Suffolk County Native Restoration Seed and Planting Lists

Where Heights up to 36" can be tolerated in passive recreation areas, it is suggested that passive turf areas be eliminated and seeded with the following mixes, selected per site conditions:

Low Growing Upland Mix

This seed mix is a lower growing, primarily native mix for general use (including roadsides and edges of paths) where little bluestem is desired or where conditions are unknown. It is tolerant of partial shade. Appropriate locations are where no mowing or infrequent mowing will occur: woodland edges, clearings, and locations where habitat and long-term soil stabilization are desired.

Little Bluestem and Virginia Wild Rye, growing to 1.5-2 feet, are intended to be the long-term dominant species, depending on sun/shade. Herbaceous species may grow 2-4 feet in height.

Herbaceous Species may be substituted with similar species under 2' HT native to Massachusetts 'Bio Basin' or 'Southern New England Coastal Plains and Hills' if those specified are not available.

	<u>Botanical Name</u>	<u>Common Name</u>	<u>% PLS By Weight</u>
Grasses	<i>Schizachyrium scoparium</i>	Little Bluestem	67.0%
	<i>Elymus Virginicus</i>	Virginia Wild Rye	25.0%
	<i>Panicum clandestinum 'Tioga'</i>	Deer Tongue	5.00%
	<i>Agrostis perennans</i>	Upland Bentgrass	4.00%
	<i>Juncus tenuis</i>	Path Rush	<u>1.00%</u>
			92.00%
Herb/Forb	<i>Chamaecrista fasciculata</i>	Partridge Pea	4.30%
	<i>Penstemon digitalis</i>	Beard-tongue	2.00%
	<i>Solidago nemoralis</i>	Grey Goldenrod	0.50%
	<i>Solidago caesia</i>	Woodland Goldenrod	0.50%
	<i>Aster cordifolius</i>	Blue Wood Aster	0.30%
	<i>Aster laevis</i>	Smooth Aster	0.20%
	<i>Pycnanthemum tenuifolium</i>	Slender Mountain Mint	<u>0.20%</u>
			<u>8.00%</u>
			100.00%

Seeding Rate

Apply this mix at 20 lbs. PLS/acre on areas of less than 3:1 slope and 60 lbs. PLS on areas of greater than 3:1 slope.

Add 30 lbs./acre of a cover crop. For a cover crop use either grain oats (1 Jan to 31 July) or grain rye (1 Aug to 31 Dec). Cover crop shall be incidental to seeding item. Cover crops must be properly cut and managed after plant establishment to prevent them from reseeding.

Low Growing Upland Mix- Full Sun

This seed mix is intended for full sun and drier soils and locations. It would be appropriate for limited mow (once year or less) medians, traffic islands, and other roadside locations where low naturalized grasses are desired.

Little Bluestem and Sheep Fescue, growing 1.5-2 feet, are intended to be the long-term dominant grass. Sheep Fescue is a low growing (12 inches) non-native, drought tolerant, cool season bunch grass. Herbaceous species may grow 2-3 feet in height.

Herbaceous Species may be substituted with similar species under 2' HT native to Massachusetts 'Bio Basin' or 'Southern New England Coastal Plains and Hills' if those specified are not available.

	<u>Botanical Name</u>	<u>Common Name</u>	<u>% PLS By Weight</u>
Grass	Festuca ovina	Sheep Fescue	80.00%
	Schizachyrium scoparium	Little Bluestem	10.70%
	Elymus virginicus	Virginia Wild Rye	5.30%
	Agrostis perennans	Upland Bentgrass	0.30%
	Juncus tenuis	Path Rush	0.70%
			<u>97.0%</u>
Herb/Forb	Chamaecrista fasciculata	Partridge Pea	1.80%
	Asclepias tuberosa	Butterfly Milkweed	0.50%
	Lespedeza capitata	Round Headed Bush Clover	0.30%
	Aster laevis	Smooth Aster	0.10%
	Euthamia caroliniana	Slender Goldentop	0.20%
	Pycnanthemum tenuifolium	Slender Mountain Mint	0.10%
			<u>3.00%</u>
		100.00%	

Seeding Rate:

Apply this mix at 75 lbs. PLS/acre on areas of less than 3:1 slope and 175 lbs. PLS on areas of greater than 3:1 slope.

Add 30 lbs./acre of a cover crop. For a cover crop use either grain oats (1 Jan to 31 July) or grain rye (1 Aug to 31 Dec). Cover crop shall be incidental to seeding item. Cover crops must be properly cut and managed after plant establishment to prevent them from reseeding.

Seeding –Low Upland Native Mix – Full Sun

This seed mix is intended for areas where a lower grass is desired. Mix is intended for areas that will not be mowed or will be mowed once a year or less. Little Bluestem, which grows 1.5-3 feet in height, is intended to be the long-term dominant grass. Herbaceous species may grow 2-4 feet in height.

This mix is all native species, tolerant of dry to mesic condition and is intended for full sun locations. Appropriate for meadows, roadside slopes and shoulders, and locations where habitat and long-term soil stabilization are desired. This mix does not include fescues and should only be used where slow rate of establishment, other than nurse crops, is acceptable.

Herbaceous Species may be substituted with similar species under 36" HT native to Massachusetts 'Bio Basin' or 'Southern New England Coastal Plains and Hills' if those specified are not available

	<u>Botanical Name</u>	<u>Common Name</u>	<u>% PLS By Weight</u>
Grasses			
	<i>Schizachyrium scoparium</i>	Little Bluestem	63.30%
	<i>Elymus virginicus</i>	Virginia Wild Rye	20.00%
	<i>Panicum clandestinum 'Tioga'</i>	Deer Tongue	5.00%
	<i>Agrostis perennans</i>	Upland Bentgrass	3.00%
	<i>Juncus tenuis</i>	Path Rush	<u>1.00%</u>
			92.30%
Herb/Forb			
	<i>Chamaecrista fasciculata</i>	Partridge Pea	4.50%
	<i>Asclepias tuberosa</i>	Butterfly Milkweed	1.50%
	<i>Lespedeza capitata</i>	Roundhead Bush Clover	1.00%
	<i>Pycnanthemum tenuifolium</i>	Slender Mountain Mint	0.30%
	<i>Euthamia caroliniana</i>	Slender Goldentop	0.30%
	<i>Aster laevis</i>	Smooth Aster	<u>0.10%</u>
			<u>7.70%</u>
			100.00%

Seeding Rate:

Apply this mix at 10 lbs. PLS/acre on areas of less than 3:1 slope and 25 lbs. PLS on areas of greater than 3:1 slope.

Add 30 lbs./acre of a cover crop. For a cover crop use either grain oats (1 Jan to 31 July) or grain rye (1 Aug to 31 Dec). Cover crops must be properly cut and managed after plant establishment to prevent them from reseeding.

Northeast Showy Mix- Full Sun

This seed mix is intended for full sun where pollinator habitat is desirable. It would be appropriate for limited mow (once year or less) locations.

Herbaceous Species may be substituted with similar species under 36" HT native to Massachusetts 'Bio Basin' or 'Southern New England Coastal Plains and Hills' if those specified are not available.

	<u>Botanical Name</u>	<u>Common Name</u>	<u>% PLS By Weight</u>
Grass			
	<i>Schizachyrium scoparium</i>	Little Blue Stem	39.50%
	<i>Bouteloua curtipendula 'Butte'</i>	Sideoats Grama 'Butte'	23.10%
	<i>Elymus virginicus</i>	Virginia Wild Rye	14.00%

		76.60%
Herb/Forb		
<i>Echinacea purpurea</i>	Purple Coneflower	7.00%
<i>Chamaecrista fasciculata</i>	Partridge Pea	5.00%
<i>Penstemon digitalis</i>	Beard-tongue	3.50%
<i>Asclepias tuberosa</i>	Butterfly Milkweed	2.50%
<i>Rudbeckia triloba</i>	Brown Eyed Susan	1.00%
<i>Aster laevis</i>	Smooth Aster	1.00%
<i>Zizia aurea</i>	Golden Alexanders	0.50%
<i>Senna hebecarpa</i>	Wild Senna	0.50%
<i>Tradescantia ohimensis</i>	Ohio Spiderwort	0.50%
<i>Aster novae-angliae</i>	New England Aster	0.40%
<i>Aster pilosus</i>	Heath Aster	0.40%
<i>Pycnanthemum tenuifolium</i>	Slender Mountain Mint	0.30%
<i>Solidago nemoralis</i>	Grey Goldenrod	0.30%
<i>Aster prenanthoides</i>	Zig Zag Aster	0.20%
<i>Solidago juncea</i>	Early Goldenrod	0.20%
<i>Baptisia tinctoria</i>	Wild Indigo	0.10%
		<u>23.40%</u>
		100.00%

Seeding Rate:

Apply this mix at 20 lbs PLS/acre on areas of less than 3:1 slope and 25 lbs PLS on areas of greater than 3:1 slope.

Add 30 lbs/acre of a cover crop. For a cover crop use either grain oats (1 Jan to 31 July) or grain rye (1 Aug to 31 Dec). Cover crops must be properly cut and managed after plant establishment to prevent them from reseeding.

Upland Shade Mix

Mix of native species and annual rye for more densely shaded areas of roadside or bike paths. Intended for no mow or minimal mow conditions. Height of grasses and forbs ranges from 1-3 feet.

Herbaceous Species may be substituted with similar species under 30" HT native to Massachusetts 'Bio Basin' or 'Southern New England Coastal Plains and Hills' if those specified are not available

<u>Botanical Name</u>	<u>Common Name</u>	<u>% PLS By Weight</u>
Grass		
<i>Elymus virginicus</i>	Virginia Wild Rye	32.00%
<i>Panicum clandestinum</i>	Deer Tongue	30.00%
<i>Agrostis perennans</i>	Upland Bentgrass	20.00%
<i>Juncus tenuis</i>	Path Rush	5.00%
<i>Carex vulpinoidea</i>	Fox Sedge	<u>3.00%</u>
		90.0%
Herb/Forb		

<i>Chamaecrista fasciculata</i>	Partridge Pea	5.00%
<i>Aster divaricatus</i>	White Wood Aster	3.00%
<i>Solidago caesia</i>	Woodland Goldenrod	<u>2.00%</u>
		<u>10.00%</u>
		100.00%

Seeding Rate:

Apply this mix at 30 lbs. PLS/acre on areas of less than 3:1 slope and 25 lbs. PLS on areas of greater than 3:1 slope. No cover crop is recommended.

Roadside Riverbank - Part Shade Mix

This mix contains species tolerant of sun – part shade conditions and very dry to moist soils. Grasses are relatively low-growing. Good for roadside edge or banks that may be periodically mowed.

Herbaceous Species may be substituted with similar species under 30" HT native to Massachusetts 'Bio Basin' or 'Southern New England Coastal Plains and Hills' if those specified are not available.

<u>Botanical Name</u>	<u>Common Name</u>	<u>% PLS By Weight</u>
Grass		
<i>Elymus virginicus</i>	Virginia Wild Rye	30.00%
<i>Elymus canadensis</i>	Canada Wild Rye	25.00%
<i>Schizachyrium scoparium</i>	Little Bluestem	22.00%
<i>Dichanthelium clandestinum</i>	Deertongue grass	8.00%
<i>Agrostis perennans</i>	Upland Bentgrass	6.00%
<i>Carex vulpinoidea</i>	Fox Sedge	2.00%
<i>Juncus tenuis</i>	Path Rush	2.00%
<i>Juncus effusus</i>	Soft Rush	<u>0.10%</u>
		<u>95.10%</u>
Herb/Forb		
<i>Penstemon digitalis</i>	Beard-tongue	2.00%
<i>Aster novae-angliae</i>	New England Aster	1.00%
<i>Solidago caesia</i>	Woodland Goldenrod	0.50%
<i>Aster cordifolius</i>	Blue Wood Aster	0.50%
<i>Eupatorium maculatum</i>	Joe-pye Weed	0.30%
<i>Geum canadense</i>	White Avens	0.30%
<i>Solidago rigida</i>	Rigid Goldenrod	0.30%
		<u>4.90%</u>
		100.00%

Seeding Rate:

Apply this mix at 20 lbs PLS/acre on areas of less than 3:1 slope and 25 lbs PLS on areas of greater than 3:1 slope.

Add 30 lbs/acre of a cover crop. For a cover crop use either grain oats (1 Jan to 31 July) or grain rye (1 Aug to 31 Dec). Cover crops must be properly cut and managed after plant establishment to prevent them from reseeding.

Roadside Riverbank – Full sun

This mix contains native species tolerant of dry to mesic conditions. Good for slopes or riverbanks where soils range from dry to moist, that will not be mowed and where a tall, dense grass stand is desired.

Herbaceous Species may be substituted with similar species under 30" HT native to Massachusetts 'Bio Basin' or 'Southern New England Coastal Plains and Hills' if those specified are not available.

<u>Botanical Name</u>	<u>Common Name</u>	<u>% PLS By Weight</u>
Grass		
Andropogon gerardii 'Niagara	Big Bluestem 'Niagara	24.00%
Sorghastrum nutans	Indiangrass	22.00%
Elymus virginicus	Virginia Wild Rye	20.00%
Panicum virgatum	Switchgrass	8.00%
Dichanthelium clandestinum 'Tioga'	Deertongue grass 'Tioga'	10.00%
Agrostis perennans	Upland Bentgrass	4.00%
Carex vulpinoidea	Fox Sedge	2.00%
Juncus tenuis	Path Rush	1.00%
Juncus effuses	Soft Rush	<u>1.00%</u>
		92.00%
Herb/Forb		
Verbena hastata	Blue Vervain	6.0%
Desmodium canadense	Showy Tick Trefoil	1.40%
Aster novae-angliae	New England Aster	0.50%
Asclepias incarnata	Swamp Milkweed	0.50%
Eupatorium maculatum	Joe-pye Weed	0.30%
Solidago juncea	Early Goldenrod	0.20%
Solidago rigida	Rigid Goldenrod	0.20%
Rudbeckia hirta	Black-eyed Susan	<u>0.10%</u>
		<u>8.0%</u>
		100.00%

Seeding Rate:

Apply this mix at 20 lbs PLS/acre on areas of less than 3:1 slope and 25 lbs PLS on areas of greater than 3:1 slope.

Add 30 lbs/acre of a cover crop. For a cover crop use either grain oats (1 Jan to 31 July) or grain rye (1 Aug to 31 Dec). Cover crops must be properly cut and managed after plant establishment to prevent them from reseeding.

Conversion to Meadows of primarily forbs:

See Type C Lists

Trees for use in Turf Areas

Acer rubrum – Red Maple

Amelanchier canadensis - Serviceberry

Celtis occidentalis – Hackberry

Fagus grandifolia – American Beech

Nyssa sylvatica- Black Tupelo

Platanus occidentalis - Sycamore

Quercus alba – White Oak

Quercus coccinea – Scarlet Oak

Quercus velutina – Black Oak

Quercus bicolor – Swamp White Oak

Swida florida – Flowering Dogwood

Tilia americana – Basswood

Ulmus americana 'Homestead' – Homestead Elm

Ulmus americana 'Valley Forge' – American Elm

Meadows and River's Edge

Upland meadow appropriate species can be chosen by utilizing the following indicator categories:

OBL – Obligate Wetland; commonly found in wetlands-near the water

FACW – Facultative Wetland; commonly found in wetlands; but may occur in areas other than wetlands

FAC – Facultative; found in wetlands and non-wetlands

FACU – Facultative Upland; commonly found in non-wetlands but may occur in wetlands

Grasses, Sedges & Rushes

Agrostis perennans – Autumn Bentgrass – FACU – shade tolerant

Andropogon gerardii– Big Bluestem - FACU

Andropogon virginicus – Broom Sedge - FACU

Calamagrostis canadensis – Canada Bluejoint Grass – OBL

Carex amphibola - Creek sedge- FAC– shade tolerant

Carex lurida – Lurid Sedge - OBL

Carex utriculata – Common Beaked Sedge - OBL

Danthonia spicata – Poverty Grass

Deschampsia flexuosa - Wavy Hairgrass – FACU - Shade Tolerant

Elymus hystrix – Bottlebrush – FACU - Shade Tolerant

Elmus virginicus – Virginia Wildrye - FACW

Elymus riparius – Riverbank Wildrye

Festuca subverticillata - Nodding fescue- FACU– shade tolerant

Glyceria striata – Fowl Mannagrass - OBL

Juncus canadensis – Canada Rush - OBL

Juncus effusus – Soft Rush - OBL

Juncus effuses var. solutus – Lamp Rush

Juncus tenuis – Path Rush - FAC

Leersia oryzoides – Rice Cutgrass - OBL

Panicum virgatum– Switchgrass - FAC

Schizachyrium scoparium – Little Bluestem

Scirpus cyperinus – Woolgrass - OBL

Sorghastrum nutans – Indiangrass - FACU

Perennials & Ferns

Actaea pachypoda - White Baneberry- UPL – shade tolerant

Actaea rubra- Red Baneberry- FACU– shade tolerant

Ageratina altissima) - White Snakeroot- UPL– shade tolerant

Anaphalis margaritace - Pearly Everlasting- FACU

Anemone virginiana - Thimbleberry- FACU– shade tolerant

Apocynum androsaemifolium - Spreading Dogbane- UPL

Apocynum cannabinum – Dogbane - FAC

Aquilegia canadensis – Red Columbine – FACU - Shade Tolerant

Asclepias incarnata – Swamp Milkweed – OBL

Asclepias purpureascens - Purple Milkweed- FACU

Asclepias tuberosa – Butterfly Weed

Asclepias verticillate - Whorled Milkweed- UPL

Aster novae-angliae – New England

Aster Baptisia tinctorial - Yellow Wild Indigo- UPL

Bidens frondosa – Devil's Pitchfork - FACW

Chamaecrista fasciculata - Partridge Pea – FACU
Chelone glabra - White turtlehead – OBL– shade tolerant
Coreopsis rosea – Rose Coreopsis - FACW
Desmodium canadense – Showy Ticktrefoil – FAC
Eragrostis spectabilis – Purple Lovegrass – UPL
Eupatorium dubium ‘Little Joe’ – Little Joe Pyeweed
Eschscholzia californica - California poppy (Annual, for pollinators)
Eupatorium maculatum - Spotted Joe Pye Weed – FACW
Eupatorium perfoliatum – Common Boneset – FACW
Eurybia divaricata - White Wood Aster – Shade Tolerant
Eurybia macrophylla - Bigleaf aster- UPL– shade tolerant
Euthamia graminifolia- Flat topped Goldenrod- FAC
Geranium maculatum - Wild Geranium – FACU
Geranium x. magnificum – Purple Cranesbill
Gratiola aurea – Golden Pert - OBL
Helianthus decapetalus - Thinleaf Sunflower- FACU
Hieracium spp. – Hawkweed
Hierochloa odorata - Sweetgrass-UPL
Hypericum mutilum – Dwarf St. John’s Wort - FACW
Iris versicolor – Blue Flag Iris - OBL
Lechea intermedia var. intermedia – Largepod Pinweed
Lechea maritima – Beach Pinweed
Lechea mucronata – Hairy Pinweed
Lechea spp. – Pinweed
Lechea tenuifolia - Slender Pinweed
Lupinus perennis – Wild Blue Lupine
Oenothera biennis - Evening Primrose- FACU
Onoclea sensibilis - Sensitive fern - FACW– shade tolerant
Penstemon digitalis – Beard Tongue - FAC
Pycnanthemum muticum – Short-toothed Mountain Mint – FAC
Pycnanthemum flexuosum – Appalachian Mountain Mint - FACW
Pycnanthemum tenuifolium – Narrow-leafed Mountain Mint
Pycnanthemum virginiana – Virginia Mountain Mint
Solidago bicolor – Silverrod – Shade Tolerant
Solidago caesia – Bluestem Goldenrod – FACU - Shade Tolerant
Solidago nemoralis – Grey Goldenrod – Shade Tolerant
Solidago sempervirens - Seaside goldenrod- FACW
Solidago speciose - Showy Goldenrod- UPL
Symphyotrichum leave -Smooth Blue Aster- FACU
Symphyotrichum cordifolium – Blue Wood Aster – Shade Tolerant
Thalictrum dioicum - Early Meadow Rue- FACU– shade tolerant
Verbena hastata – Blue Vervain - FACW
Zizia aurea – Golden Alexander – Shade Tolerant – FAC

Circulation

* Salt and pollution tolerant trees and shrubs

Street Trees

Celtis occidentalis – Hackberry
Liquidambar styraciflua - Sweetgum
Ulmus americana ‘Homestead’ – Homestead Elm
Ulmus americana ‘Valley Forge’ – American Elm

Shoreline Trees

Acer negundo – Box Elder
Acer saccharinum – Silver Maple
Betula papyrifera – Paper Birch
Betula populifolia – Grey Birch
Carpinus caroliniana – American Hornbeam
Juniperus virginiana – Eastern Red Cedar
Prunus serotina – Black Cherry
Quercus bicolor – Swamp White Oak
Quercus rubra – Red Oak
Salix caroliniana – Coastal Plain Willow
Salix interior - Sandbar Willow
Salix nigra – Black Willow

Shrubs

Ilex glabra - Inkberry
Morella pennsylvanica – Bayberry
Prunus maritima – Beach Plum
Rubus flagellaris – Northern Dewberry
Salix discolor – Pussy Willow
Spiraea tomentosa – Steeplebush

Vines

Parthenocissus quinquefolia – Virginia Creeper
*existing woodlands only – will overtop new plantings

*See Type A Seed lists for seed mixes appropriate to roadsides

River’s Edge

Shrubs

Arctostaphylos uva-ursi – Bearberry
Ceanothus americanus- New Jersey Tea
Comptonia peregrina – Sweet Fern
Dasiphora fruticosa – Shrubby Cinquefoil
Fragaria virginiana - Wild Strawberry
Gaylussacia baccata – Black Huckleberry
Kalmia angustifolia – Sheep-Laurel
Rosa virginiana – Virginia Rose
Rubus flagellaris – Northern Dewberry
Spiraea tomentosa – Steeplebush

Vaccinium angustifolium - Lowbush blueberry

Perennials & Ferns

Asclepias tuberosa – Butterfly Weed

Campanula rotundifolia – Harebell

Capnoides sempervirens – Pink corydalis

Dennstaedtia punctilobula - Hay-scented Fern

Geranium maculatum - Wild Geranium

Gratiola aurea – Golden Pert

Iris versicolor – Blue Flag Iris

Lupinus perennis – Wild lupine

Lycopus americanus – American Water Horehound

Melampyrum lineare – Common Cow-Wheat

Nuttallanthus canadensis – Blue Toadflax

Onoclea sensibilis – Sensitive Fern

Osmundastrum cinnamomea – Cinnamon Fern

Osmunda claytonia – Interrupted Fern

Osmunda regalis – Royal Fern

Packera aurea - Golden Groundsel- FACW

Plantago rugelli – American Plantain

Pteridium aquilinum – Bracken Fern

Pycnanthemum muticum - Short-toothed Mountainmint

Rudbeckia laciniata – Tall Coneflower

Sabatia kennedyana – Plymouth Rose Gentian *Silene caroliniana* - Wild Pinks/ Catchfly *Verbena hastata* – Blue Vervain

Viola pedate - Bird's Foot Violet

Grasses, Rushes & Sedges

Carex amphibola – Creek Sedge

Deschampsia flexuosa - Common Hair Grass

Elymus hystrix – Bottlebrush Grass

Eragrostis spectabilis – Purple Love Grass

Juncus tenuis - Poverty Rush

Sisyrinchium angustifolium - Blue-Eyed Grass

Sporobolus vaginiflorus - Poverty Grass

Vines/ Groundcovers

Parthenocissus quinquefolia – Virginia Creeper

Type F: Medium to High Shrub with Overstory

Trees

Amelanchier arborea – Tall Shadbush

Benthamidia florida – Flowering Dogwood

Betula papyrifera – Paper Birch

Carya cordiformis – Bitternut Hickory

Carya ovata – Shagbark Hickory

Carya tomentosa – Mockernut Hickory

Juniperus virginiana – Eastern Red Cedar

Quercus ilicifolia – Bear Oak

Shrubs

Amelanchier spicata – Thicket Shadbush
Amelanchier stolonifera – Running Serviceberry
Aronia arbutifolia – Red Chokeberry
Aronia melanocarpa – Black Chokeberry
Cephalanthus occidentalis – Buttonbush
Clethra alnifolia – Summersweet Clethra
Cornus amomum - Silky Dogwood
Cornus racemose - Gray Dogwood
Corylus americana – American Hazelnut
Hamamelis virginiana - American Witchhazel
Ilex verticillate - Common Winterberry
Lindera benzoin – Spicebush
Prunus maritima – Beach Plum
Rubus allegheniensis - Common Blackberry
Rhus glabra - Smooth Sumac
Rhus typhina – Staghorn Sumac
Rubus odoratus - Purple-flowering Raspberry
Salix bebbiana - Bebb Willow
Salix discolor - Pussy Willow
Salix nigra - Black Willow
Sambucus canadensis – Elderberry
Spiraea tomentosa – Steeplebush
Swida alternifolia – Pagoda Dogwood
Swida amomum – Silky Dogwood
Swida racemosa – Gray Dogwood
Swida rugosa – Round-leaved Dogwood
Viburnum acerifolium – Mapleleaf Viburnum
Vaccinium angustifolium – Lowbush Blueberry
Vaccinium corymbosum – Highbush Blueberry
Viburnum dentatum – Arrowwood Viburnum
Viburnum lantanoides – Hobblebush
Viburnum lentago – Nannyberry
Viburnum nudum – Smooth Witherod
Viburnum trilobum - American Cranberrybush

Perennials

Asclepias tuberosa – Butterfly Weed
Eutorchium fistulosum – Joe Pye Weed
Senna hebecarpa - Wild Senna
Symphotrichum novae-angliae – New England Aster
Symphotrichum novi-belgii - New York Aster
Teucrium canadense - American Germander
Verbena hastata - Swamp Verbena
Vernonia noveboracensis - New York Ironweed

Grasses

Eragrostis spectabilis – Purple Love Grass

Wooded

Trees

Acer pensylvanicum – Striped Maple
Acer rubrum – Red Maple
Acer saccharinum – Silver Maple
Amelanchier laevis – Allegheny Serviceberry
Amelanchier canadensis – Serviceberry
Betula alleghaniensis – Yellow Birch
Betula lenta- Black Birch
Betula papyrifera- Paper Birch
Betula populifolia- Grey Birch
Carpinus caroliniana— American Hornbeam
Carya ovata – Shagbark Hickory
Cornus alternifolia- Pagoda Dogwood
Nyssa sylvatica - Black Tupelo
Ostrya virginiana – American Hop Hornbeam
Platanus occidentalis – American
 Sycamore *Pinus strobus* – White Pine
Populus grandidentata – Big-toothed Aspen
Populus tremuloides – Quaking Aspen
Prunus serotina – Black Cherry
Quercus bicolor - Swamp White Oak
Quercus coccinea – Scarlet Oak
Quercus rubra – Red Oak
Quercus velutina – Black Oak
Sassafras albidum – Sassafras
Salix nigra – Black Willow
Tilia americana – American Basswood

Shrubs

Alnus incana – Speckled Alder
Alnus serrulata – Smooth Alder
Aronia arbutifolia– Red chokeberry
Aronia melanocarpa – Black Chokeberry
Clethra alnifolia – Summersweet
Corylus americana – American Hazelnut
Diasphora floribuda – Shrubby cinquefoil
Hamamelis virginiana – American Witchhazel
Hypericum canadense – Canadian St. John’s Wort
Hypericum mutilum - Dwarf St. John’s Wort
Hypericum punctatum – Spotted St. John’s Wort
Ilex verticillata – Common Winterberry
Lindera benzoin – Spicebush
Prunus virginiana – Choke Cherry
Rubus allegheniensis - Common Blackberry
Rubus odoratus – Purple-flowering Raspberry
Viburnum lantanoides – Hobblebush
Viburnum lentago – Nannyberry
Viburnum nudum L. var. *cassinoides* – Witherod Viburnum
Viburnum trilobum – American Cranberrybush

Perennials & Ferns

Actaea pachypoda – White Baneberry
Actaea rubra – Red Baneberry
Adiantum pedatum – Maidenhair Fern
Ageratina altissima (Eupatorium rugosum) – White Snakeroot
Apocynum cannabinum – Dogbane
Aralia racemosa – Spikenard
Asplenium platyneuron – Ebony Spleenwort
Asplenium trichomanes ssp. trichomanes – Maidenhair Spleenwort
Athyrium filix-femina – Lady Fern
Carex amphibola – Creek sedge
Carex appalachica – Appalachian Sedge
Carex pensylvanica – Pennsylvania sedge
Carex platyphylla – Silver Sedge
Dendrolycopodium dendroideum – Ground Pine
Dryopteris marginalis – Marginal Shield Fern
Dennstaedtia punctilobula – Hay-scented fern
Dryopteris marginalis – Wood Fern
Eurybia divaricata - Whitewood Aster
Eurybia macrophylla – Bigleaf aster
Fragaria virginiana – Wild Strawberry
Gaultheria procumbens – Wintergreen
Gentiana andrewsii – Closed Gentian
Geranium maculatum – Wild Geranium
Ionactis linariifolia – Flaxleaf whitetop aster
Maianthemum canadense – Canada Mayflower
Maianthemum stellatum – Star-Flowered False Solomon Seal
Mitchella repens – Partridge Berry
Onoclea sensibilis – Sensitive fern
Osmundastrum cinnamomeum – Cinnamon Fern
Osmunda claytoniana – Interrupted fern
Osmunda regalis – Royal fern
Packera aurea (Senecio aureus) – Golden Groundsel
Polystichum acrostichoides – Christmas fern
Pteridium aquilinum - Bracken fern
Sanguinaria canadensis – Bloodroot
Symphyotrichum cordifolium – Blue Heart-Leaf Aster
Thelypteris noveboracensis – New York Fern
Tiarella cordifolia – Foam Flower

Vines/ Groundcovers

Clematis virginiana – Wild Clematis
Parthenocissus quinquefolia – Virginia Creeper
Vitis riparia – Riverbank Grape

CHARLES RIVER BASIN RIVERBANK VEGETATION MANAGEMENT PLAN

MASSACHUSETTS DEPARTMENT OF CONSERVATION AND RECREATION

DCR CONTRACT NO.: P18-3241-S1A



Weston & Sampson Engineers, Inc.
85 Devonshire Street, 3rd Floor
Boston, MA 02109
978.532.1900 800.SAMPSON
www.westonandsampson.com

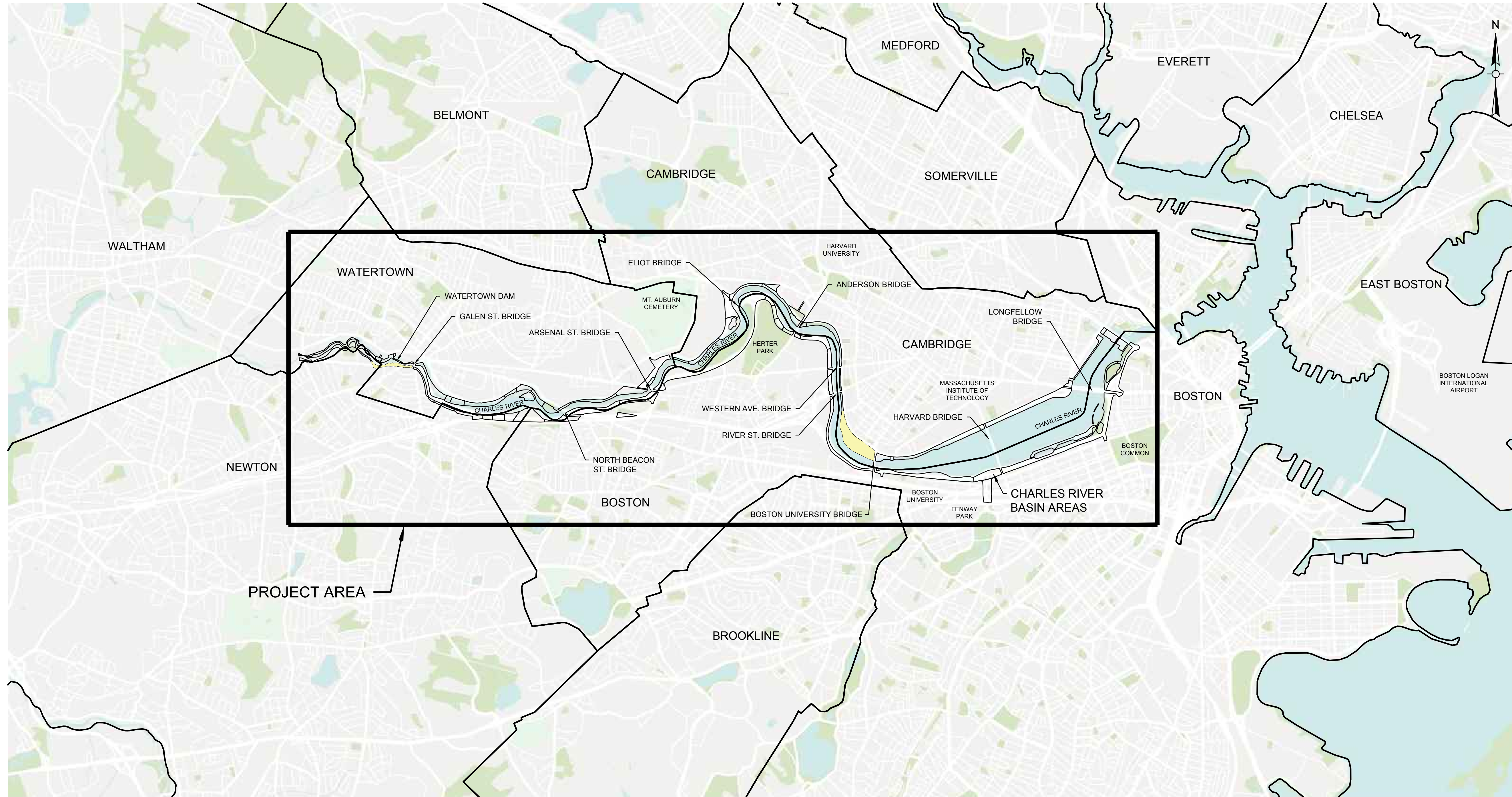

LOCATION MAP
NOT SCALE

DRAWING INDEX

SHEET	TITLE
G000	COVER SHEET
G001	KEY PLAN
C101	TEST PLOT 1
C102	TEST PLOT 2
C103	TEST PLOT 3
C104	TEST PLOT 4
C105	TEST PLOT 5
C106A	TEST PLOT 6A - SHADE MEADOW
C106B	TEST PLOT 6B - SUN MEADOW
C107	TEST PLOT 7
C108	TEST PLOT 8
C501	EROSION AND SEDIMENT CONTROL DETAILS
C502	PLANTING DETAILS
C503	PLANTING DETAILS
C504	PLANTING DETAILS



CHARLES D. BAKER,
GOVERNOR

KARYN E. POLITO,
LT. GOVERNOR

KATHLEEN A. THEOCHARIDES,
SECRETARY, EXECUTIVE
OFFICE OF ENERGY &
ENVIRONMENTAL AFFAIRS

JIM MONTGOMERY,
ACTING COMMISSIONER,
DEPARTMENT OF
CONSERVATION &
RECREATION



MASSACHUSETTS DEPARTMENT OF
CONSERVATION AND RECREATION

JIM MONTGOMERY
DCR COMMISSIONER
251 CAUSEWAY STREET, SUITE 600
BOSTON, MA 02114

Issued Date:

MARCH 2021

Sheet Number:



Know what's below.
Call before you dig.

G000

Issued For:

FOR PERMITTING USE ONLY -
NOT FOR CONSTRUCTION

TEST PLOT 1 - NOTES:

SITE PREPARATION

- WHERE SCOURING/SUMPING OF THE RIVERBANK IS FOUND BEHIND RIPRAP, INSTALL GEOTEXTILE AND SILT FENCE ACCORDING TO SLOPE STABILIZATION DETAIL 5, SHEET C501. SPECIFIC PLACEMENT OF FIBER ROLLS SLOPE STABILIZATION, AND SILT FENCE WILL BE DIRECTED BY THE OWNER'S REPRESENTATIVE.
- INVASIVE/NUISANCE SPECIES REMOVAL SHALL BE PERFORMED ACCORDING TO SPECIFICATIONS. IF ADDITIONAL INVASIVE/NUISANCE SPECIES NOT FOUND ON THIS LIST ARE FOUND, CONTRACTOR SHALL RECOMMEND TREATMENT PROCEDURES FOR REVIEW & APPROVAL BY THE OWNER'S REPRESENTATIVE. DOCUMENTED INVASIVE SPECIES ON THE SITE INCLUDE THE FOLLOWING:

SCIENTIFIC NAME	COMMON NAME
<i>Amorpha fruticosa</i>	FALSE INDIGO
<i>Celastrus orbiculatus</i>	ASIATIC BITTERSWEET
<i>Iris pseudacorus</i>	YELLOW IRIS
<i>Convolvulus arvensis</i>	HEDGE BINDWEED
<i>Cuscuta spp.</i>	DODDER

- EXISTING NATIVE SPECIES ARE TO REMAIN IN THE RESTORATION AREA. CONTRACTOR SHALL PROVIDE PROTECTIONS TO ENSURE NATIVE SPECIES ARE NOT DISTURBED OR DAMAGED BY INVASIVE REMOVAL AND RESTORATION PLANTING. CONTRACTOR SHALL OBTAIN APPROVAL FROM OWNER'S REPRESENTATIVE WHEN TRANSPLANT OR REMOVAL OF NATIVE SPECIES IS UNAVOIDABLE. ADDITIONAL NATIVE SPECIES NOT FOUND ON THIS LIST MAY EXIST AND SHALL RECEIVE THE SAME PROTECTIONS. DOCUMENTED NATIVE SPECIES INCLUDE THE FOLLOWING:

SCIENTIFIC NAME	COMMON NAME
<i>Onoclea sensibilis</i>	SENSITIVE FERN
<i>Aster spp.</i>	ASTER
<i>Tradescantia spp.</i>	SPIDERWORT
<i>Solidago spp.</i>	GOLDENROD
<i>Viola spp.</i>	VIOLET

- COMPACTED SOILS IN THE RESTORATION AREA SHALL BE LOOSENEED TO A DEPTH OF 12" MIN.
- CONTRACTOR SHALL NOT DISTURB OR RELOCATE EXISTING RIPRAP.
- THE CONTRACTOR SHALL INSTALL ALL REQUIRED POLLUTION CONTROL DEVICES PRIOR TO CONSTRUCTION AND SHALL BE RESPONSIBLE FOR THEIR MAINTENANCE, REPOSITIONING, AND REMOVAL UPON COMPLETION OF WORK. REQUIRED POLLUTION CONTROL DEVICES INCLUDE BUT ARE NOT LIMITED TO SILT FENCE, FIBER ROLLS, AND SLOPE STABILIZATION MATTING.
- CONTRACTOR SHALL NOT DAMAGE RIVERBANKS. RIVERBANKS SHALL BE CHECKED WEEKLY TO ENSURE THEY ARE STRUCTURALLY SOUND AND HAVE NOT BEEN DAMAGED BY RESTORATION WORK.
- THE EXTENT OF THE RESTORATION AREA MAY VARY FROM THE EXTENT SHOWN ON THE DRAWINGS BASED ON ACTUAL CONSTRUCTION MEANS AND METHODS. THE CONTRACTOR SHALL FIELD VERIFY RESTORATION BOUNDARIES WITH OWNER'S REPRESENTATIVE PRIOR TO CONSTRUCTION.

PLANTING

- PLANT MATERIAL SHALL BE PROVIDED BY DCR AND INSTALLED BY CONTRACTOR AS INDICATED IN THE APPROVED WORK PLAN AND DRAWINGS.
- RESTORATION AREAS SHALL BE CHECKED WEEKLY AND AFTER EACH RAINFALL EVENT PRODUCING AT LEAST ONE INCH OF PRECIPITATION TO ENSURE PLANTINGS ARE INTACT AND EROSION AND SEDIMENT STRUCTURES ARE STRUCTURALLY SOUND.
- AFTER CONTAINER AND PLUG PLANTS HAVE BEEN INSTALLED, SEED ALL DISTURBED AREAS WITH CUSTOM SEED MIX SEEDED AT SUPPLIER'S SUGGESTED RATES OF THE FOLLOWING SPECIES:

SCIENTIFIC NAME	COMMON NAME
<i>Acorus americanus</i>	SWEET FLAG
<i>Eurybia divaricata</i>	WHITE WOOD ASTER
<i>Iris versicolor</i>	BLUE FLAG IRIS
<i>Juncus tenuis</i>	PATH RUSH
<i>Schizachyrium scoparium</i>	LITTLE BLUESTEM
<i>Symphotrichum novae-angliae</i>	NEW ENGLAND ASTER

REFER TO SPECIFICATIONS FOR ADDITIONAL PRODUCT INFORMATION AND INSTALLATION INSTRUCTIONS.

PLANTING SCHEDULE

KEY	BOTANIC NAME	COMMON NAME	QUANTITY	SIZE / SPACING
SHRUBS				
AU	ARCTOSTAPHYLOS UVA - URSI	BEARBERRY	33	1 GAL.; 24" O.C.
CA	CEANOTHUS AMERICANUS	NEW JERSEY TEA	28	15 - 18" HT.; 18" O.C.
PERENNIALS / FERNS				
AA	ACORUS AMERICANUS	SWEET FLAG	55	PLUG; 12" O.C.
ED	EURYBIA DIVARICATA	WHITE WOOD ASTER	81	1 GAL.; 12" O.C.
FV	FRAGARIA VIRGINIANA	WILD STRAWBERRY	96	2 QT.; 12" O.C.
IV	IRIS VERSICOLOR	BLUE FLAG IRIS	28	2 QT.; 12" O.C.
OS	ONOCLEA SENSIBILIS	SENSITIVE FERN	16	1 GAL.; 18" O.C.
SS	SCHIZACHYRIUM SCOPARIUM	LITTLE BLUESTEM	222	PLUG; 6" O.C.
SN	SYMPHOTRICHUM NOVAE - ANGLIAE	NEW ENGLAND ASTER	81	1 GAL.; 12" O.C.

**APPROXIMATE LATITUDE/
LONGITUDE OF TEST PLOTS**

PLOT NO.	LATITUDE	LONGITUDE
PLOT 1	42.3647	-71.0720

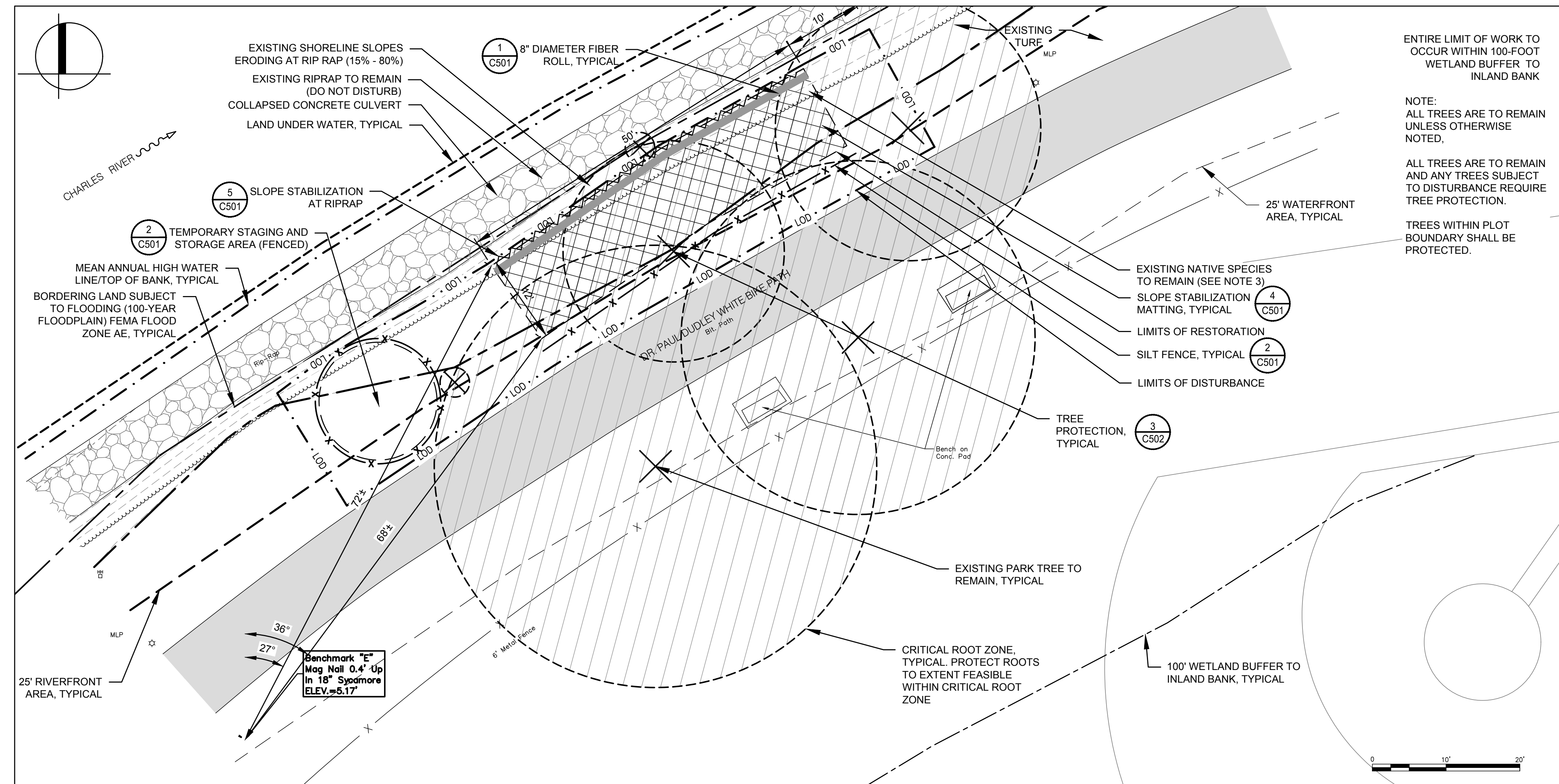

1 TEST PLOT 1 - SITE PREPARATION
SCALE: 1" = 10'

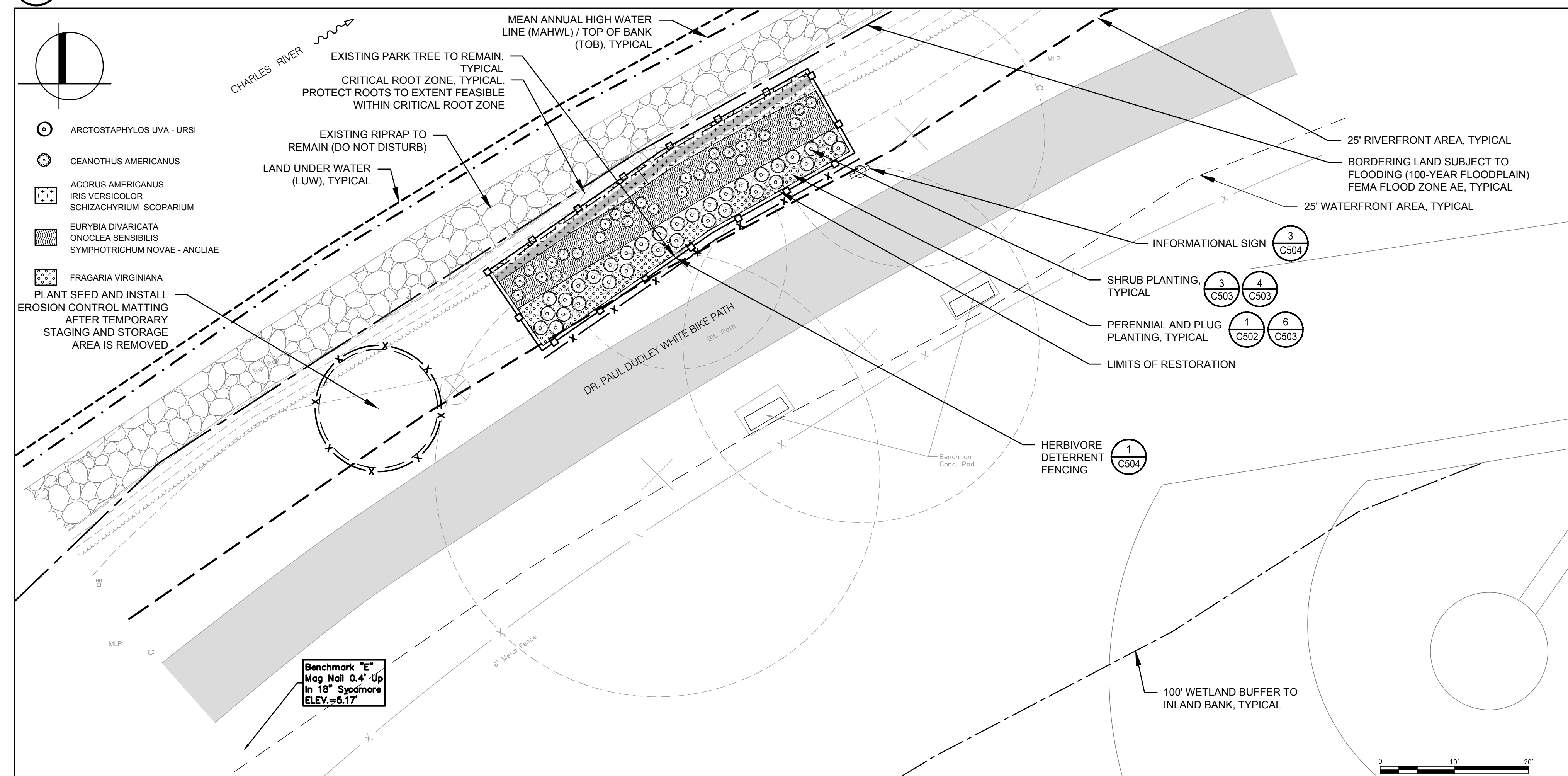

2 TEST PLOT 1 - PLANTING PLAN
SCALE: 1" = 10'

ENTIRE LIMIT OF WORK TO OCCUR WITHIN 100-FOOT WETLAND BUFFER TO INLAND BANK

NOTE:
ALL TREES ARE TO REMAIN UNLESS OTHERWISE NOTED.

ALL TREES ARE TO REMAIN AND ANY TREES SUBJECT TO DISTURBANCE REQUIRE TREE PROTECTION.

TREES WITHIN PLOT BOUNDARY SHALL BE PROTECTED.

Project:
MASSACHUSETTS DEPARTMENT OF CONSERVATION AND RECREATION
dcr
Massachusetts
CHARLES RIVER BASIN RIVERBANK VEGETATION MANAGEMENT PLAN

Weston & Sampson
85 Devonshire Street, 3rd Floor,
Boston, MA 02109
617-412-4480 800.SAMPSON
www.westonandsampson.com

Consultants:

No.	Date	Description

Revisions:

No.	Date	Description

Seal:

Issued For:

FOR PERMITTING USE ONLY - NOT FOR CONSTRUCTION

Scale: 1" = 10'

Date: MARCH 2021

Drawn By: RAM

Reviewed By: DPB

Approved By: CFR

W&S Project No: P18-3241-S1A

W&S File No:

Drawing Title:

TEST PLOT 1

Sheet Number:

C101

TEST PLOT 2 - NOTES:

SITE PREPARATION

- FIBER ROLLS SHALL BE INSTALLED ALONG THE RIVERBANK AND SILT FENCE SHALL BE INSTALLED ALONG THE NORTHERN EDGE OF THE PLANTING AREA ADJACENT TO THE LAWN. SPECIFIC PLACEMENT OF FIBER ROLLS SHALL BE DIRECTED BY THE OWNER'S REPRESENTATIVE.
- INVASIVE/NUISANCE SPECIES REMOVAL SHALL BE PERFORMED ACCORDING TO SPECIFICATIONS. IF ADDITIONAL INVASIVE/NUISANCE SPECIES NOT FOUND ON THIS LIST ARE FOUND, CONTRACTOR SHALL RECOMMEND TREATMENT PROCEDURES FOR REVIEW & APPROVAL BY THE OWNER'S REPRESENTATIVE. DOCUMENTED INVASIVE SPECIES ON THE SITE INCLUDE THE FOLLOWING:

SCIENTIFIC NAME	COMMON NAME
<i>Amorpha fruticosa</i>	FALSE INDIGO
<i>Phragmites australis</i>	COMMON REED
<i>Iris pseudacorus</i>	YELLOW IRIS
<i>Convolvulus arvensis</i>	HEDGE BINDWEED
<i>Cuscuta spp.</i>	DODDER

- EXISTING NATIVE SPECIES ARE TO REMAIN IN THE RESTORATION AREA. CONTRACTOR SHALL PROVIDE PROTECTIONS TO ENSURE NATIVE SPECIES ARE NOT DISTURBED OR DAMAGED BY INVASIVE REMOVAL AND RESTORATION PLANTING. CONTRACTOR SHALL OBTAIN APPROVAL FROM OWNER'S REPRESENTATIVE WHEN TRANSPLANT OR REMOVAL OF NATIVE SPECIES IS UNAVOIDABLE. ADDITIONAL NATIVE SPECIES NOT FOUND ON THIS LIST MAY EXIST AND SHALL RECEIVE THE SAME PROTECTIONS. DOCUMENTED NATIVE SPECIES INCLUDE THE FOLLOWING:

SCIENTIFIC NAME	COMMON NAME
<i>Oenothera biennis</i>	EVENING PRIMROSE
<i>Aster spp.</i>	ASTER

- COMPACTED SOILS IN THE RESTORATION AREA SHALL BE LOOSENED TO A DEPTH OF 12" MIN.
- CONTRACTOR SHALL NOT REMOVE EXISTING STONE MATRIX ON THE SHORELINE. PLANTS ARE TO BE PLANTED IN THE VOIDS BETWEEN THE STONE MATRIX.
- CONTRACTOR SHALL NOT DAMAGE RIVERBANKS. RIVERBANKS SHALL BE CHECKED WEEKLY TO ENSURE THEY ARE STRUCTURALLY SOUND AND HAVE NOT BEEN DAMAGED BY RESTORATION WORK.
- THE EXTENT OF THE RESTORATION AREA MAY VARY FROM THE EXTENT SHOWN ON THE DRAWINGS BASED ON ACTUAL CONSTRUCTION MEANS AND METHODS. THE CONTRACTOR SHALL FIELD VERIFY RESTORATION BOUNDARIES WITH OWNER'S REPRESENTATIVE PRIOR TO CONSTRUCTION.

PLANTING

- PLANT MATERIAL SHALL BE PROVIDED BY DCR AND INSTALLED BY CONTRACTOR AS INDICATED IN THE APPROVED WORK PLAN AND DRAWINGS.
- RESTORATION AREAS SHALL BE CHECKED WEEKLY AND AFTER EACH RAINFALL EVENT PRODUCING AT LEAST ONE INCH OF PRECIPITATION TO ENSURE PLANTINGS ARE INTACT AND EROSION AND SEDIMENT STRUCTURES ARE STRUCTURALLY SOUND.
- AFTER CONTAINER AND PLUG PLANTS HAVE BEEN INSTALLED, SEED ALL DISTURBED AREAS WITH CUSTOM SEED MIX SEEDED AT SUPPLIER'S SUGGESTED RATES OF THE FOLLOWING SPECIES:

SCIENTIFIC NAME	COMMON NAME
<i>Asclepias tuberosa</i>	BUTTERFLY WEED
<i>Carex vulpinoidea</i>	FOX SEDGE
<i>Deschampsia flexuosa</i>	COMMON HAIRGRASS
<i>Iris versicolor</i>	BLUE FLAG IRIS
<i>Juncus tenuis</i>	PATH RUSH
<i>Schizachyrium scoparium</i>	LITTLE BLUESTEM

REFER TO SPECIFICATIONS FOR ADDITIONAL PRODUCT INFORMATION AND INSTALLATION INSTRUCTIONS.

PLANTING SCHEDULE

KEY	BOTANIC NAME	COMMON NAME	QUANTITY	SIZE / SPACING
SHRUBS				
CP	COMPTONIA PEREGRIA	SWEET FERN	18	3 GAL.; 24" O.C.
PERENNIALS / FERNS				
AT	ASCLEPIAS TUBEROSA	BUTTERFLY WEED	50	PLUG; 12" O.C.
IV	IRIS VERSICOLOR	BLUE FLAG IRIS	100	2 QT.; 12" O.C.
GRASSES / SEDGES / RUSHES				
CA	CAREX AMPHIBOLA	CREEK SEDGE	100	1 GAL.; 12" O.C.
DF	DESCHAMPSIA FLEXUOSA	COMMON HAIRGRASS	74	1 GAL.; 10" O.C.
JT	JUNCUS TENUIS	PATH RUSH	74	PLUG; 10" O.C.
SS	SCHIZACHYRIUM SCOPARIUM	LITTLE BLUESTEM	50	PLUG; 12" O.C.

APPROXIMATE LATITUDE/LONGITUDE OF TEST PLOTS		
PLOT NO.	LATITUDE	LONGITUDE
PLOT 2	42.3566	-71.0758

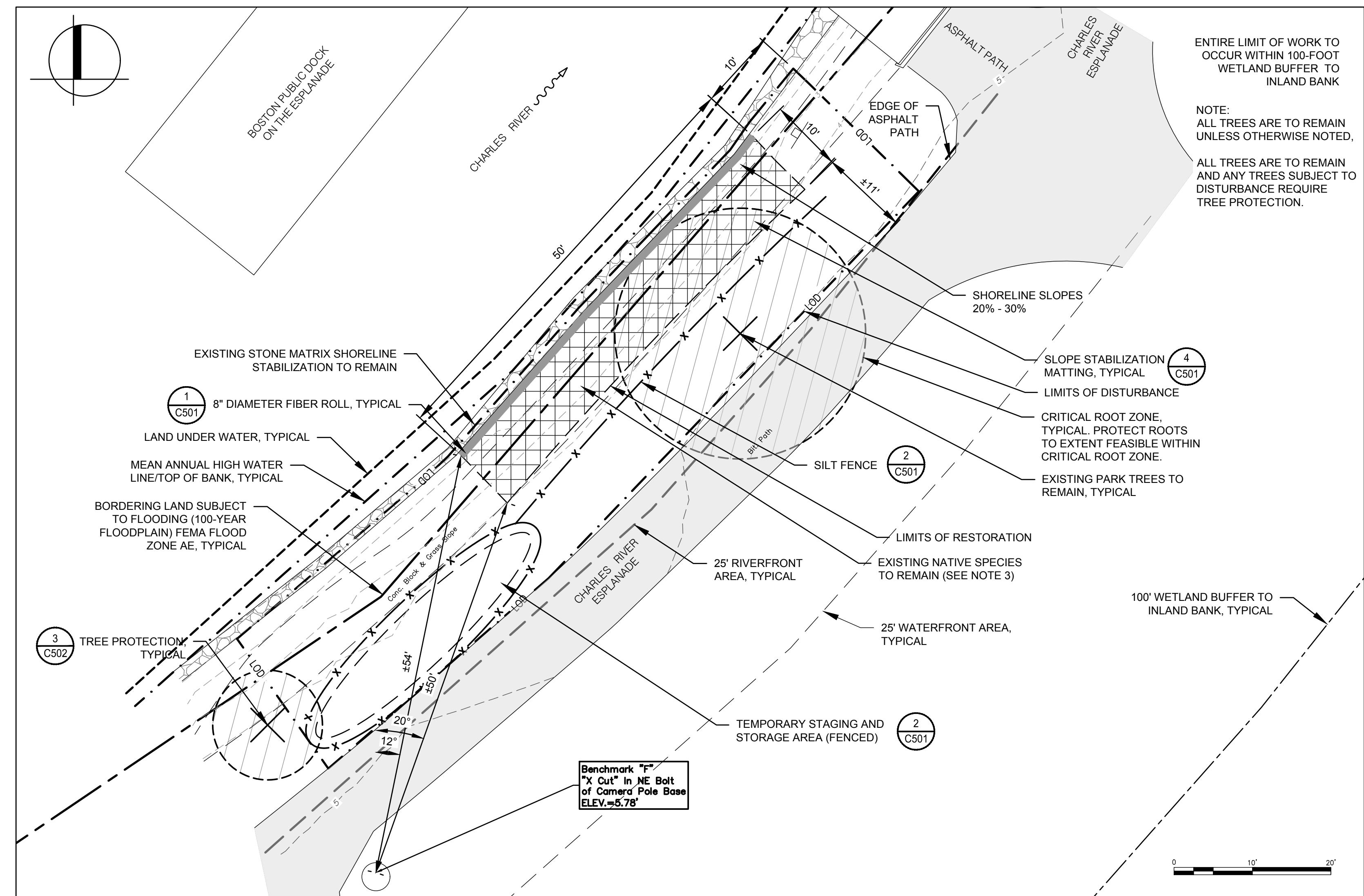

1 TEST PLOT 2 - SITE PREPARATION

SCALE: 1" = 10'

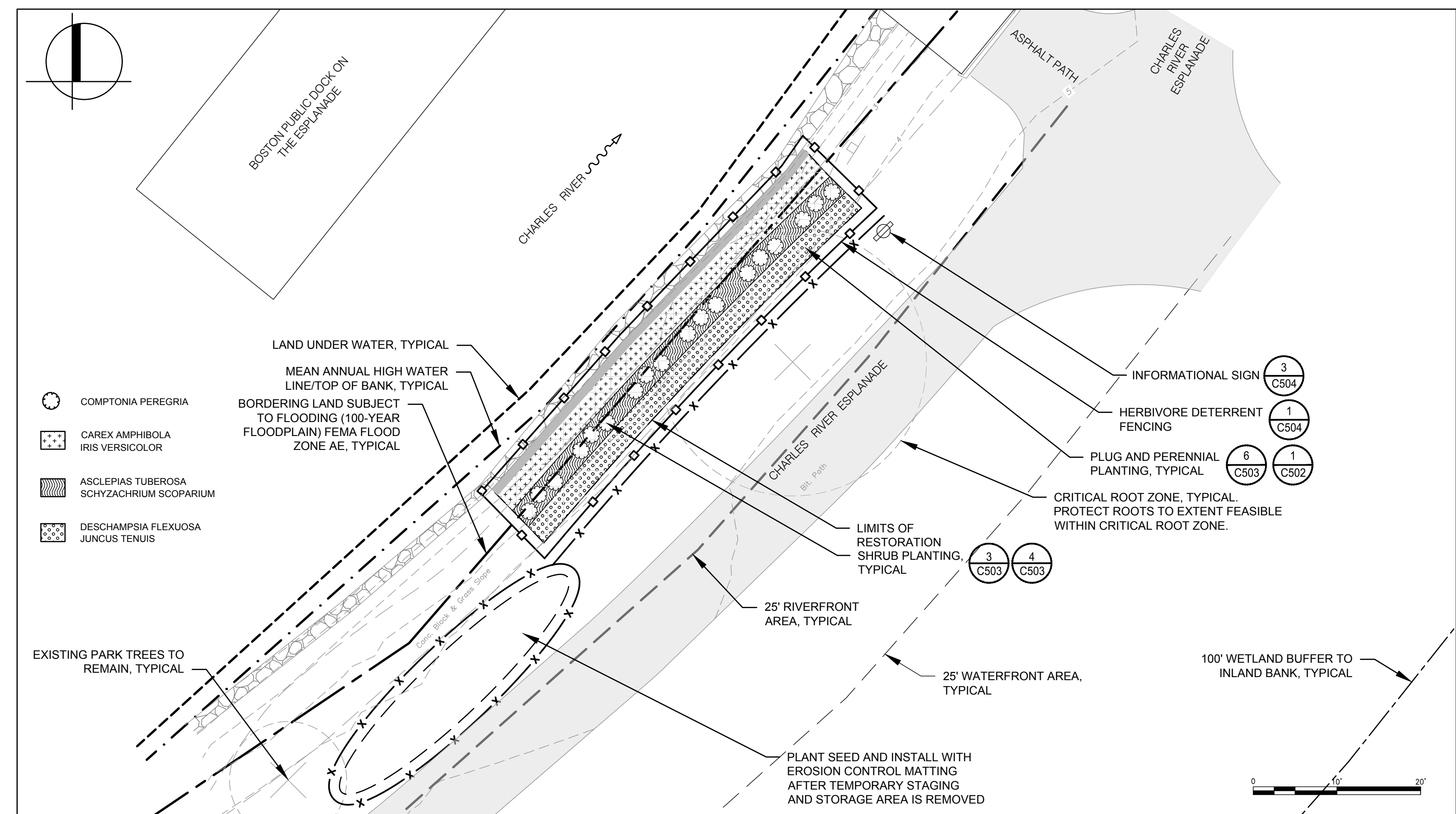

2 TEST PLOT 2 - PLANTING PLAN

SCALE: 1" = 10'

Consultants:

Revisions:

No.	Date	Description

Seal:

Issued For:

FOR PERMITTING USE ONLY - NOT FOR CONSTRUCTION

Scale: 1" = 10'

Date: MARCH 2021

Drawn By: RAM

Reviewed By: DPB

Approved By: CFR

W&S Project No: P18-3241-S1A

W&S File No:

Drawing Title:

TEST PLOT 2

Sheet Number:

C102

TEST PLOT 3 - NOTES:

SITE PREPARATION

- DCR SHALL UTILIZE INTERNAL CERTIFIED ARBORIST TO ASSESS AND COORDINATE REMOVAL OF HAZARDOUS LIMBS OR BRANCHES BEFORE WORK BEGINS.
- WHERE SCOURING/SLUMPING OF THE RIVERBANK IS FOUND BEHIND RIPRAP, INSTALL GEOTEXTILE AND SILT FENCE ACCORDING TO SLOPE STABILIZATION DETAIL 5, SHEET C501. SPECIFIC PLACEMENT OF FIBER ROLLS AND SLOPE STABILIZATION WILL BE DIRECTED BY THE OWNER'S REPRESENTATIVE.
- INVASIVE/NUISANCE SPECIES REMOVAL SHALL BE PERFORMED ACCORDING TO SPECIFICATIONS. ADDITIONAL INVASIVE/NUISANCE SPECIES NOT FOUND ON THIS LIST MAY EXIST AND SHALL BE REMOVED ACCORDING TO SPECIFICATIONS. DOCUMENTED INVASIVE SPECIES ON THE SITE INCLUDE THE FOLLOWING:

SCIENTIFIC NAME	COMMON NAME
<i>Amorpha fruticosa</i>	FALSE INDIGO
<i>Lythrum salicaria</i>	PURPLE LOOSESTRIFE
<i>Iris pseudacorus</i>	YELLOW IRIS

- EXISTING NATIVE SPECIES ARE TO REMAIN IN THE RESTORATION AREA. CONTRACTOR SHALL PROVIDE PROTECTIONS TO ENSURE NATIVE SPECIES ARE NOT DISTURBED OR DAMAGED BY INVASIVE REMOVAL AND RESTORATION PLANTING. CONTRACTOR SHALL OBTAIN APPROVAL FROM OWNER'S REPRESENTATIVE WHEN TRANSPLANT OR REMOVAL OF NATIVE SPECIES IS UNAVOIDABLE. ADDITIONAL NATIVE SPECIES NOT FOUND ON THIS LIST MAY EXIST AND SHALL RECEIVE THE SAME PROTECTIONS. DOCUMENTED NATIVE SPECIES INCLUDE THE FOLLOWING:

SCIENTIFIC NAME	COMMON NAME
<i>Salix nigra</i>	WILLOW
<i>Cephalanthus occidentalis</i>	BUTTONBUSH
<i>Solidago canadensis</i>	GOLDENROD
<i>Aster spp.</i>	ASTER

- COMPACTED SOILS IN THE RESTORATION AREA SHALL BE LOOSENEED TO A DEPTH OF 12" MIN., EXCEPT WHERE SUCH ACTIVITIES MAY DAMAGE TREE ROOTS LOCATED WITHIN THE CRITICAL ROOT ZONE AS SHOWN ON PLANS.
- CONTRACTOR SHALL NOT DAMAGE RIVERBANKS. RIVERBANKS SHALL BE CHECKED REGULARLY TO ENSURE THEY ARE STRUCTURALLY SOUND AND HAVE NOT BEEN DAMAGED BY RESTORATION WORK.
- THE EXTENT OF THE RESTORATION AREA MAY VARY FROM THE EXTENT SHOWN ON THE DRAWINGS BASED ON ACTUAL CONSTRUCTION MEANS AND METHODS. THE CONTRACTOR SHALL FIELD VERIFY RESTORATION BOUNDARIES WITH OWNER'S REPRESENTATIVE PRIOR TO CONSTRUCTION.

PLANTING

- PLANT MATERIAL SHALL BE PROVIDED BY DCR AND INSTALLED BY CONTRACTOR AS INDICATED IN THE APPROVED WORK PLAN AND DRAWINGS.
- RESTORATION AREAS SHALL BE CHECKED WEEKLY AND AFTER EACH RAINFALL EVENT PRODUCING AT LEAST ONE INCH OF PRECIPITATION TO ENSURE PLANTINGS ARE INTACT AND EROSION AND SEDIMENT STRUCTURES ARE STRUCTURALLY SOUND.
- AFTER CONTAINER AND PLUG PLANTS HAVE BEEN INSTALLED, SEED ALL DISTURBED AREAS WITH CUSTOM SEED MIX, SEEDED AT SUPPLIER'S SUGGESTED RATES OF THE FOLLOWING SPECIES:

SCIENTIFIC NAME	COMMON NAME
<i>Carex vulpinoidea</i>	FOX SEDGE
<i>Deschampsia flexuosa</i>	COMMON HAIRGRASS
<i>Iris versicolor</i>	BLUE FLAG IRIS
<i>Juncus tenuis</i>	PATH RUSH

REFER TO SPECIFICATIONS FOR ADDITIONAL PRODUCT INFORMATION AND INSTALLATION INSTRUCTIONS.

PLANTING SCHEDULE

KEY	BOTANIC NAME	COMMON NAME	QUANTITY	SIZE / SPACING
SHRUBS				
GB	GAYLUSSACIA BACCATA	BLACK HUCKLEBERRY	76 SF	MIXED SOD
VA	VACCINIUM ANGSTIFOLIUM	LOW-BUSH BLUEBERRY	41 SF	MIXED SOD
PERENNIALS / FERNS				
DP	DENNSTAEDTIA PUNCTILOBULA	HAY SCENTED FERN	58 SF	MIXED SOD
IV	IRIS VERSICOLOR	BLUE FLAG IRIS	58	2 QT.; 12" O.C.
OS	ONOCLEA SENSIBILIS	SENSITIVE FERN	26	1 GAL.; 18" O.C.
GRASSES / SEDGES / RUSHES				
CA	CAREX AMPHIBOLA	CREEK SEDGE	58	1 GAL.; 12" O.C.

NOTE: HUCKLEBERRY, BLUEBERRY AND FERN SHALL BE A PRE-ESTABLISHED, MIXED SPECIES SOD.

APPROXIMATE LATITUDE/LONGITUDE OF TEST PLOTS		
PLOT NO.	LATITUDE	LONGITUDE
PLOT 3	42.3516	-71.1061

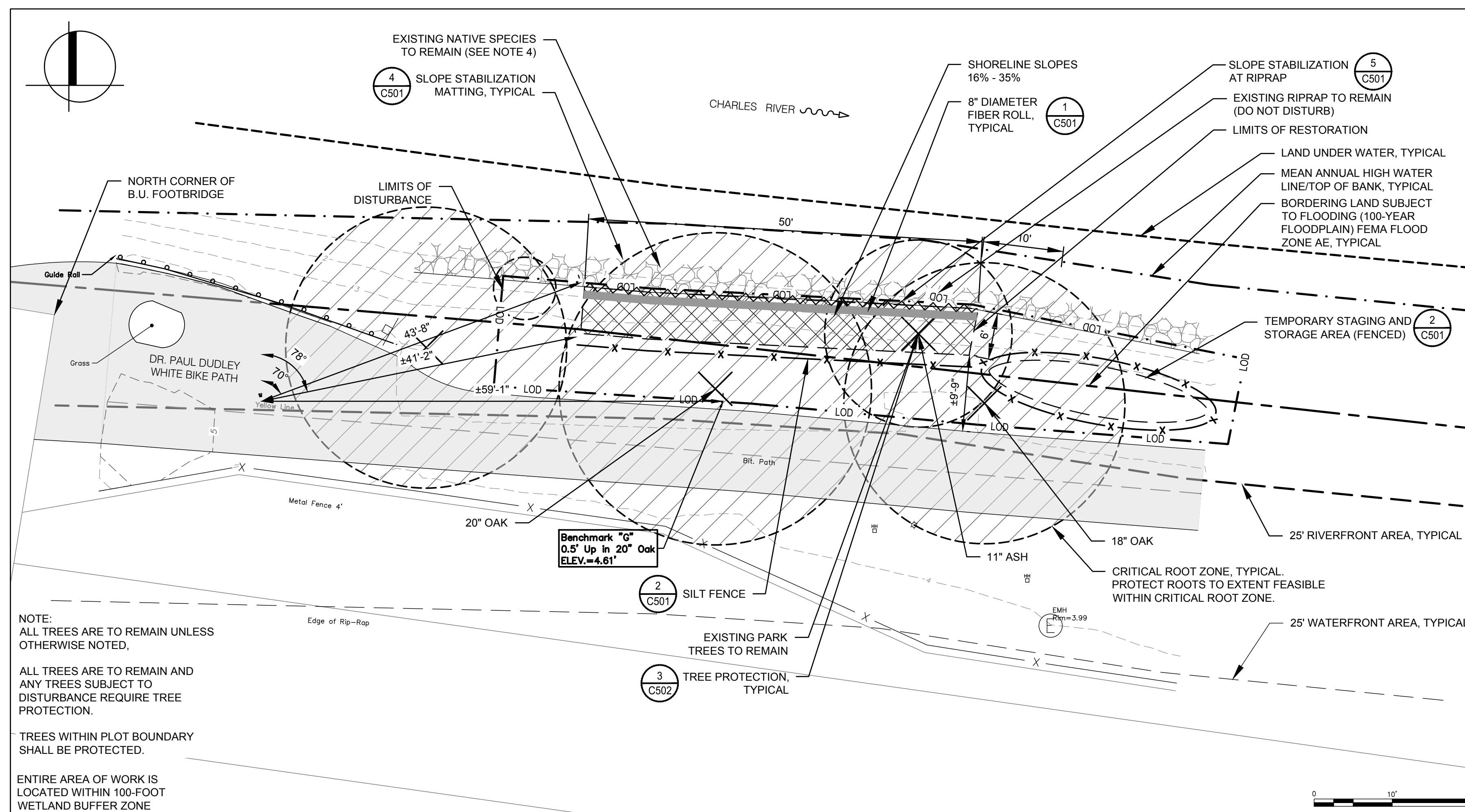

1 TEST PLOT 3 - SITE PREPARATION

SCALE: 1" = 10'

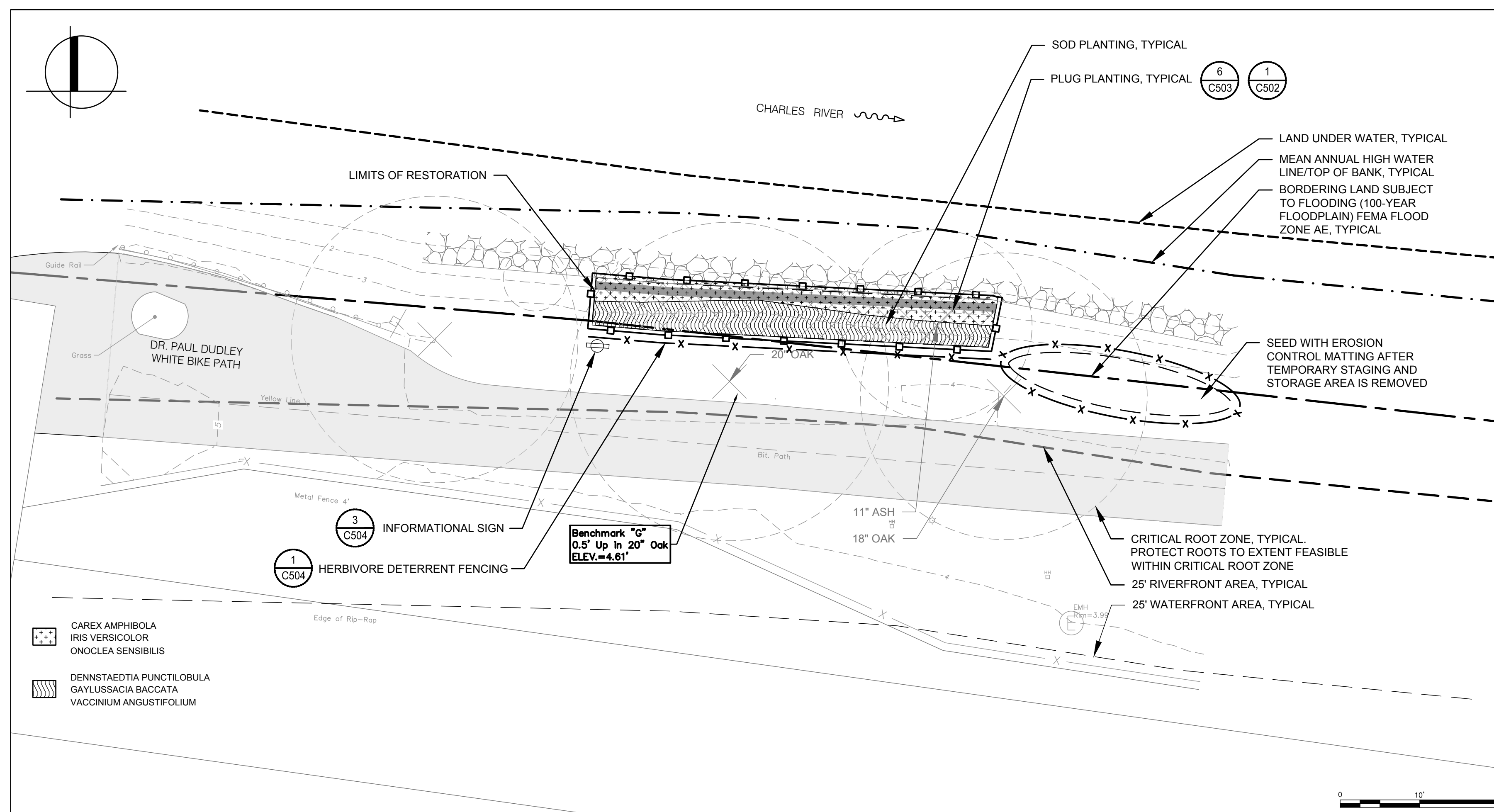

2 TEST PLOT 3 - PLANTING PLAN

SCALE: 1" = 10'

Consultants:

Revisions:

No.	Date	Description

Seal:

Issued For:

FOR PERMITTING USE ONLY - NOT FOR CONSTRUCTION

Scale: 1" = 10'

Date: MARCH 2021

Drawn By: RAM

Reviewed By: DPB

Approved By: CFR

W&S Project No: P18-3241-S1A

W&S File No:

Drawing Title:

TEST PLOT 3

Sheet Number:

C103

TEST PLOT 4 - NOTES:

GENERAL

1. SURVEY INFORMATION OBTAINED FROM PLAN TITLED "TOPOGRAPHIC PLAN MAGAZINE BEACH" BY HARRIS, R. FELDMAN, INC., REVISED JANUARY 23, 2001.

SITE PREPARATION

1. DCR SHALL UTILIZE INTERNAL CERTIFIED ARBORIST TO ASSESS AND COORDINATE REMOVAL OF HAZARDOUS LIMBS OR BRANCHES BEFORE WORK BEGINS.
2. CONTRACTOR SHALL REMOVE AND STORE NATIVE PLANT SPECIES FOUND WITHIN THE RESTORATION AREA BEFORE BEGINNING INVASIVE SPECIES CONTROL OPERATIONS. TRANSPLANTING SITES ARE TO BE COORDINATED WITH THE OWNER'S REPRESENTATIVE. CONTRACTOR RESPONSIBLE FOR MAINTENANCE AND WATERING OF TRANSPLANTED SPECIES THROUGHOUT THE DURATION OF CONTRACT.
3. INVASIVE/NUISANCE SPECIES REMOVAL SHALL BE PERFORMED ACCORDING TO SPECIFICATIONS. IF ADDITIONAL INVASIVE/NUISANCE SPECIES NOT FOUND ON THIS LIST ARE FOUND, CONTRACTOR SHALL RECOMMEND TREATMENT PROCEDURES FOR REVIEW & APPROVAL BY THE OWNER'S REPRESENTATIVE. DOCUMENTED INVASIVE SPECIES ON THE SITE INCLUDE THE FOLLOWING:

SCIENTIFIC NAME	COMMON NAME
<i>Phragmites australis</i>	COMMON REED
<i>Lythrum salicaria</i>	PURPLE LOOSESTRIFE
<i>Cirsium arvense</i>	CREEPING THISTLE

4. EXISTING NATIVE SPECIES ARE TO REMAIN IN THE RESTORATION AREA. CONTRACTOR SHALL PROVIDE PROTECTIONS TO ENSURE NATIVE SPECIES ARE NOT DISTURBED OR DAMAGED BY INVASIVE REMOVAL AND RESTORATION PLANTING. CONTRACTOR SHALL OBTAIN APPROVAL FROM OWNER'S REPRESENTATIVE WHEN TRANSPLANT OR REMOVAL OF NATIVE SPECIES IS UNAVOIDABLE. ADDITIONAL NATIVE SPECIES NOT FOUND ON THIS LIST MAY EXIST AND SHALL RECEIVE THE SAME PROTECTIONS. DOCUMENTED NATIVE SPECIES INCLUDE THE FOLLOWING:

SCIENTIFIC NAME	COMMON NAME
<i>Oenothera biennis</i>	EVENING PRIMROSE
<i>Aster spp.</i>	ASTER
<i>Asclepias tuberosa</i>	BUTTERFLY WEED
<i>Tradescantia spp.</i>	SPIDERWORT
* <i>Rudbeckia hirta</i>	BLACK-EYED SUSAN
<i>Solidago spp.</i>	GOLDENROD
<i>Scirpus cyperinus</i>	WOOLGRASS
<i>Eutrochium purpureum</i>	JOE PYE WEED
<i>Equisetum spp.</i>	HORSETAIL
* INTRODUCED SPECIES TO REMAIN	

5. EROSION AND SEDIMENT CONTROL MEASURES AND BARRIER FENCING SHALL BE INSTALLED PRIOR TO INVASIVE SPECIES REMOVAL. THE CONTRACTOR SHALL INSTALL ALL REQUIRED POLLUTION CONTROL DEVICES PRIOR TO CONSTRUCTION TO MINIMIZE RISK OF CONTAMINATION OF ADJACENT SOIL AND WATER RESOURCES. CONTRACTOR SHALL BE RESPONSIBLE FOR THEIR MAINTENANCE, REPOSITIONING, AND REMOVAL UPON COMPLETION OF WORK.
6. INFORMATIONAL SIGNAGE SHALL BE INSTALLED PRIOR TO HERBICIDE APPLICATIONS TO INFORM THE PUBLIC OF RISKS OF EXPOSURE.
7. INVASIVE SPECIES TO BE REMOVED MANUALLY. TEST PLOT AREA TO BE REASSESSED IN THE SPRING. REFER TO SPECIFICATIONS.

APPROXIMATE LATITUDE/LONGITUDE OF TEST PLOTS		
PLOT NO.	LATITUDE	LONGITUDE
PLOT 4	42.3546	-71.1138

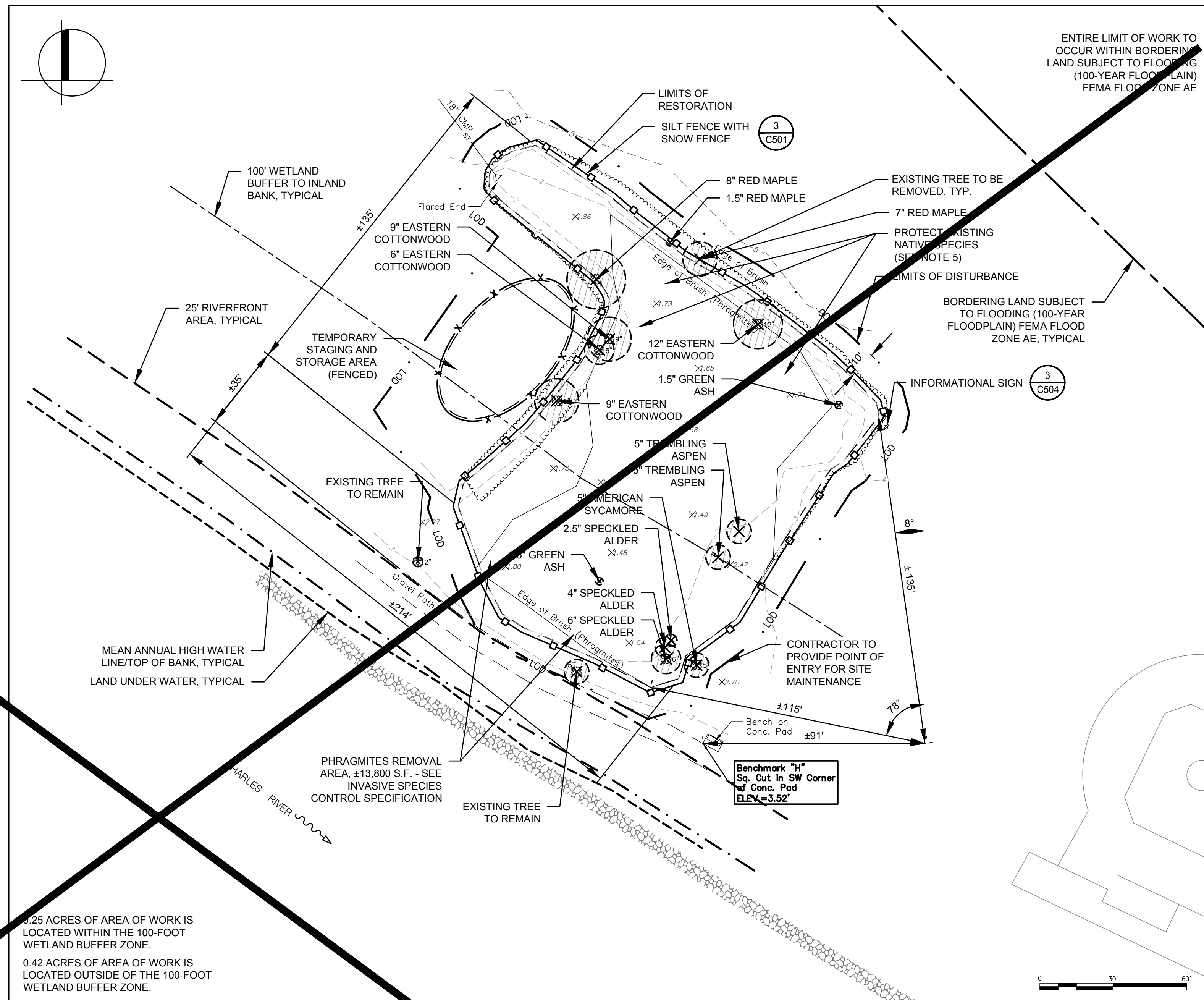

1 TEST PLOT 4 - SITE PREPARATION AND INVASIVE SPECIES REMOVAL PLAN
SCALE: 1" = 30'

SEE SHEET C104A FOR PLANTING PLAN.

Project:
MASSACHUSETTS DEPARTMENT OF CONSERVATION AND RECREATION
dcr
 Massachusetts
 CHARLES RIVER BASIN RIVERBANK VEGETATION MANAGEMENT PLAN

Weston & Sampson
 85 Devonshire Street, 3rd Floor,
 Boston, MA 02109
 617-412-4480 800.SAMPSON
 www.westonandsampson.com

Consultants:

Revisions:

No.	Date	Description

Seal:
TEST PLOT IN DEVELOPMENT - DO NOT REVIEW

Issued For:
 FOR PERMITTING USE ONLY - NOT FOR CONSTRUCTION

Scale: 1" = 30'
 Date: MARCH 2021
 Drawn By: RAM
 Reviewed By: DPB
 Approved By: CFR
 W&S Project No: P18-3241-S1A
 W&S File No:

Drawing Title:
TEST PLOT 4
 Sheet Number:
C104

TEST PLOT 7 - NOTES:

SITE PREPARATION

- THE CONTRACTOR SHALL INSTALL ALL REQUIRED POLLUTION CONTROL DEVICES PRIOR TO CONSTRUCTION AND SHALL BE RESPONSIBLE FOR THEIR MAINTENANCE, REPOSITIONING, AND REMOVAL UPON COMPLETION OF WORK.
- DCR SHALL UTILIZE INTERNAL CERTIFIED ARBORIST TO ASSESS AND COORDINATE REMOVAL OF HAZARDOUS LIMBS OR BRANCHES BEFORE WORK BEGINS.
- INVASIVE/NUISANCE SPECIES REMOVAL SHALL BE PERFORMED ACCORDING TO SPECIFICATIONS. IF ADDITIONAL INVASIVE/NUISANCE SPECIES NOT FOUND ON THIS LIST ARE FOUND, CONTRACTOR SHALL RECOMMEND TREATMENT PROCEDURES FOR REVIEW & APPROVAL BY THE OWNER'S REPRESENTATIVE. DOCUMENTED INVASIVE SPECIES ON THE SITE INCLUDE THE FOLLOWING:

SCIENTIFIC NAME	COMMON NAME
<i>Fallopia japonica</i>	JAPANESE KNOTWEED
<i>Artemisia vulgaris</i>	MUGWORT
<i>Ailanthus altissima</i>	TREE OF HEAVEN

- EXISTING NATIVE SPECIES ARE TO REMAIN IN THE RESTORATION AREA. CONTRACTOR SHALL PROVIDE PROTECTIONS TO ENSURE NATIVE SPECIES ARE NOT DISTURBED OR DAMAGED BY INVASIVE REMOVAL AND RESTORATION PLANTING. CONTRACTOR SHALL OBTAIN APPROVAL FROM OWNER'S REPRESENTATIVE WHEN TRANSPLANT OR REMOVAL OF NATIVE SPECIES IS UNAVOIDABLE. ADDITIONAL NATIVE SPECIES NOT FOUND ON THIS LIST MAY EXIST AND SHALL RECEIVE THE SAME PROTECTIONS. DOCUMENTED NATIVE SPECIES INCLUDE THE FOLLOWING:

SCIENTIFIC NAME	COMMON NAME
<i>Rhus typhina</i>	STAGHORN SUMAC
<i>Phytolacca americana</i>	AMERICAN POKEBERRY
<i>Solidago canadensis</i>	GOLDENROD

- THE CONTRACTOR SHALL PREVENT THE TRANSPORT OF INVASIVE PLANT MATERIAL TO AND FROM THE SITE, EQUIPMENT, VEHICLES, PERSONAL GEAR, AND IMPORTED MATERIALS SHALL BE CLEAN AND FREE OF PLANT MATERIAL.
- ONLY MATERIALS ACCEPTABLE TO THE OWNER SHALL BE USED IN THE FILL MIXTURE. REFER TO SPECIFICATIONS. SOIL AMENDMENTS SHALL BE ADDED TO CORRECT DEFICIENCIES LISTED IN THE SOIL TESTING REPORT. REFER TO SPECIFICATIONS. INCORPORATE FERTILIZER, pH ADJUSTERS, AND SOIL CONDITIONERS TO SOIL AT A MINIMUM OF 3" BY HARROWING, TILING, OR OTHER METHOD APPROVED BY THE OWNER'S REPRESENTATIVE PENDING OWNER'S APPROVAL.
- THE CONTRACTOR SHALL INSTALL ALL REQUIRED POLLUTION CONTROL DEVICES PRIOR TO CONSTRUCTION AND SHALL BE RESPONSIBLE FOR THEIR MAINTENANCE, REPOSITIONING, AND REMOVAL UPON COMPLETION OF WORK.
- CONTRACTOR SHALL NOT DAMAGE RIVERBANKS. THE BULKHEAD AND RIVERBANK SLOPE SHALL BE CHECKED REGULARLY TO ENSURE THEY ARE STRUCTURALLY SOUND AND HAVE NOT BEEN DAMAGED BY RESTORATION WORK.
- THE EXTENT OF THE RESTORATION AREA MAY VARY FROM THE EXTENT SHOWN ON THE DRAWINGS BASED ON ACTUAL CONSTRUCTION MEANS AND METHODS. THE CONTRACTOR SHALL FIELD VERIFY RESTORATION BOUNDARIES WITH OWNER'S REPRESENTATIVE PRIOR TO CONSTRUCTION.
- EXCAVATION SHALL BE LIMITED TO (3) THREE-FOOT DEPTH IN THE VICINITY OF THE EXISTING RETAINING WALL.

PLANTING

- PLANT MATERIAL SHALL BE PROVIDED BY DCR AND INSTALLED BY CONTRACTOR AS INDICATED IN THE APPROVED WORK PLAN AND DRAWINGS.
- RESTORATION AREAS SHALL BE CHECKED WEEKLY AND AFTER EACH RAINFALL EVENT PRODUCING AT LEAST ONE INCH OF PRECIPITATION TO ENSURE PLANTINGS ARE INTACT AND EROSION AND SEDIMENT STRUCTURES ARE STRUCTURALLY SOUND.
- AFTER CONTAINER AND PLUG PLANTS HAVE BEEN INSTALLED, SEED ALL DISTURBED AREAS WITH CUSTOM SEED MIX, SEEDED AT SUPPLIER'S SUGGESTED RATES, OF THE FOLLOWING SPECIES:

SCIENTIFIC NAME	COMMON NAME
<i>Asclepias tuberosa</i>	BUTTERFLY WEED
<i>Deschampsia flexuosa</i>	COMMON HAIRGRASS
<i>Eragrostis spectabilis</i>	PURPLE LOVE GRASS
<i>Eutrochium fistulosum</i>	JOE PYE WEED
<i>Juncus tenuis</i>	PATH RUSH
<i>Schizachyrium scoparium</i>	LITTLE BLUESTEM
<i>Symphotrichum novae-angliae</i>	NEW ENGLAND ASTER

REFER TO SPECIFICATIONS FOR ADDITIONAL PRODUCT INFORMATION AND INSTALLATION INSTRUCTIONS.

PLANTING SCHEDULE

KEY	BOTANIC NAME	COMMON NAME	QUANTITY	SIZE / SPACING
SHRUBS				
AM	ARONIA MELANOCARPA	BLACK CHOKEBERRY	11	3'-4" HT, 148" O.C.
CA	CLETHRA ALNIFOLIA	SUMMERSWEET CLETHRA	19	3 GAL, 36" O.C.
CS	CORNUS AMOMUM	SILKY DOGWOOD	25	0.5'-1.5' DIA, LIVE STAKE, 24" O.C.
CW	CORNUS AMOMUM	SILKY DOGWOOD	25	4-5" DIA WATTLE, 24" O.C.
GL	GAYLUSSACIA BACCATA	BLACK HUCKLEBERRY	24	1 GAL, 12" O.C.
SD	SALIX DISCOLOR	PUSSY WILLOW	5	2 GAL, 36" O.C.
PERENNIALS / FERNS				
AT	ASCLEPIAS TUBEROSA	BUTTERFLY WEED	162	PLUG, 6" O.C.
EF	EUTROCHUM FISTULOSUM	JOE PYE WEED	100	PLUG, 6" O.C.
SN	SYMPHOTRICHUM NOVAE-ANGLIAE	NEW ENGLAND ASTER	100	PLUG, 6" O.C.
GRASSES / SEDGES / RUSHES				
CA	CAREX AMPHIBOLA	CREEK SEDGE	220	PLUG, 6" O.C.
CP	CAREX PENNSYLVANICA	PENNSYLVANIA SEDGE	162	PLUG, 6" O.C.
JT	JUNCUS TENUIS	PATH RUSH	220	PLUG, 6" O.C.
SS	SCHIZACHRYLIUM SCOPARIUM	LITTLE BLUESTEM	220	PLUG, 6" O.C.

APPROXIMATE
LATITUDE/LONGITUDE
OF TEST PLOTS

PLOT NO.	LATITUDE	LONGITUDE
PLOT 7	42.3608	-71.1489

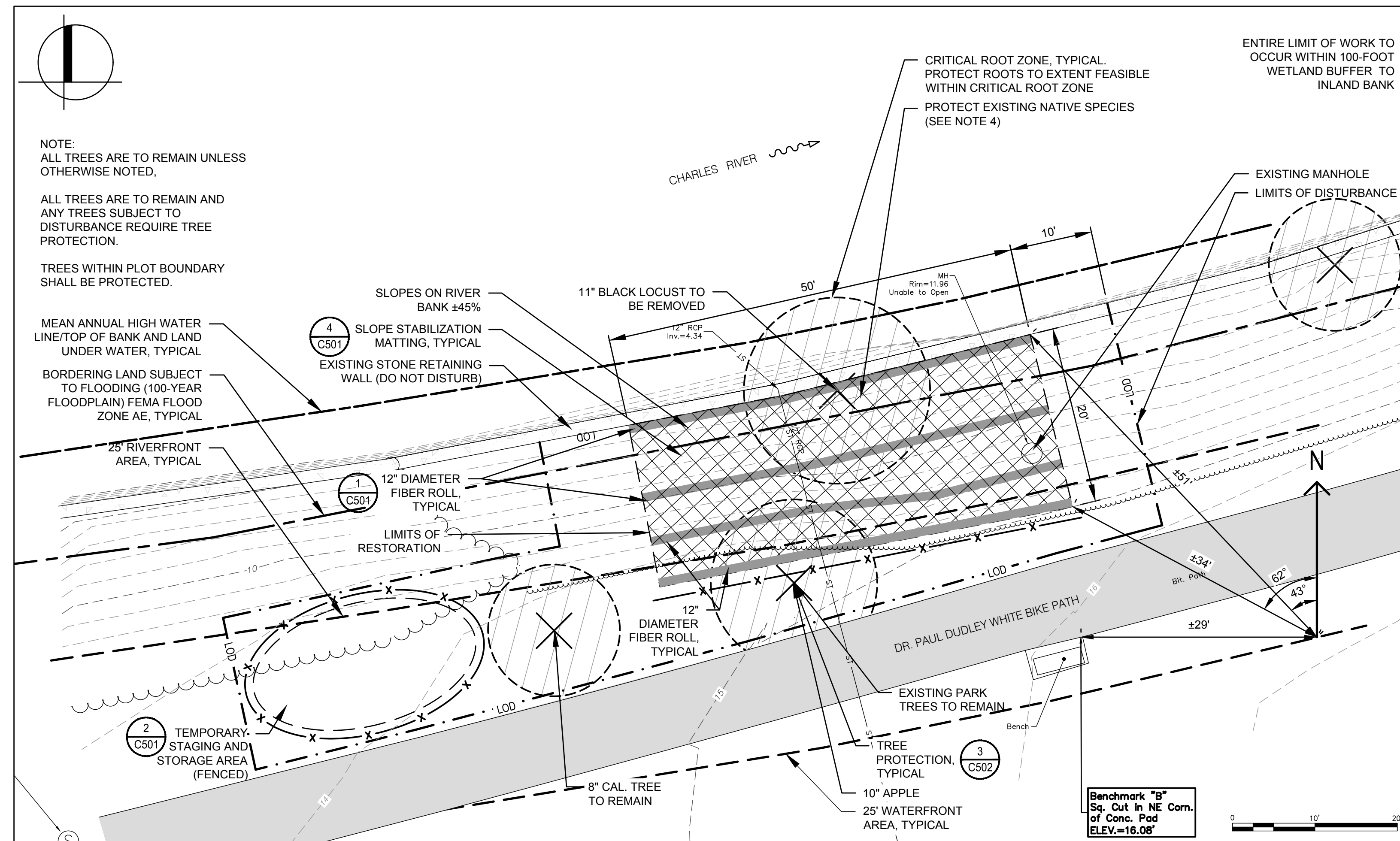

1 TEST PLOT 7 - SITE PREPARATION
SCALE: 1" = 10'

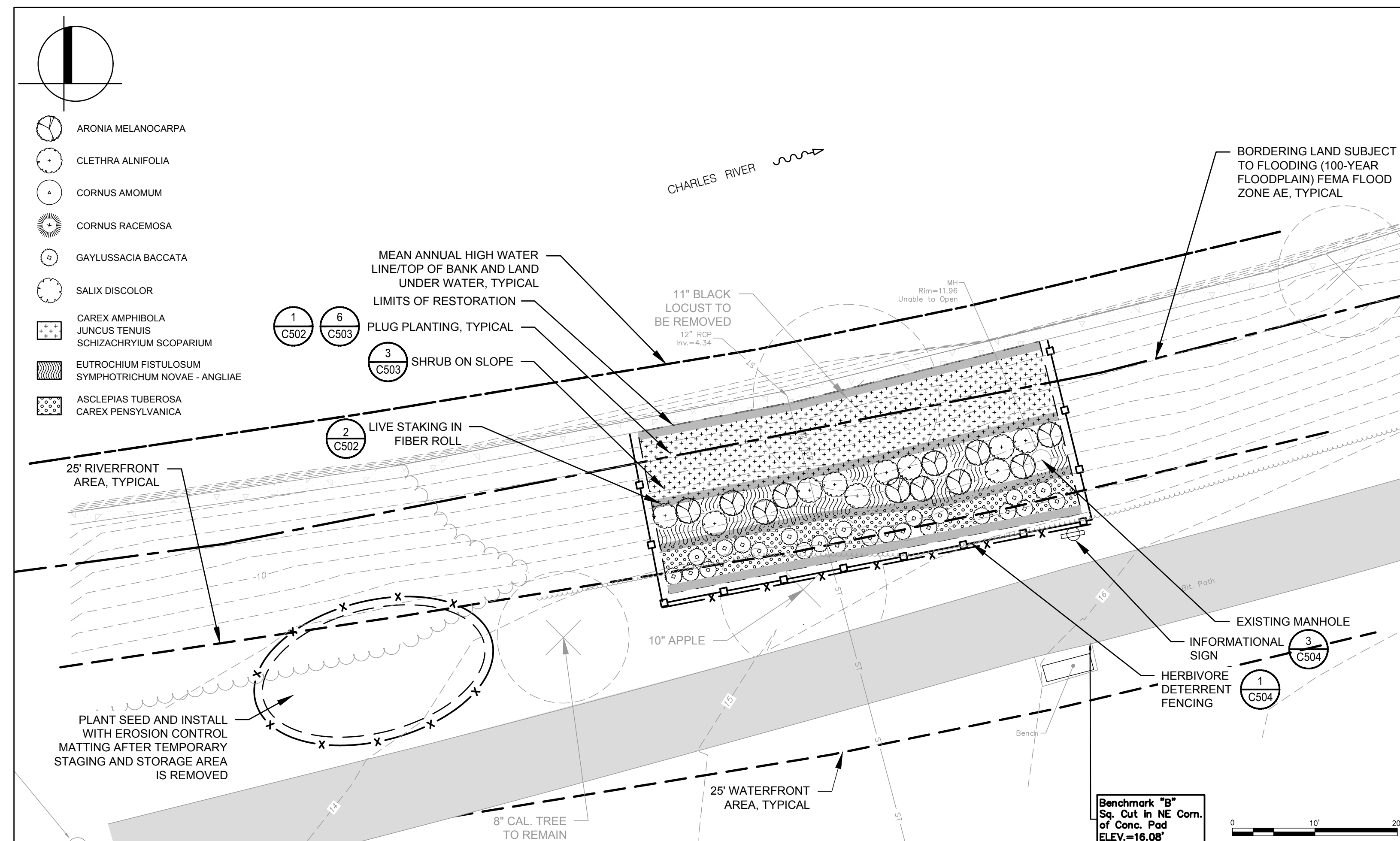

2 TEST PLOT 7 - PLANTING PLAN
SCALE: 1" = 10'

Consultants:

No.	Date	Description

Revisions:

Seal:

Issued For:

FOR PERMITTING USE ONLY - NOT FOR CONSTRUCTION

Scale: 1" = 10'

Date: MARCH 2021
Drawn By: RAM
Reviewed By: DPB
Approved By: CFR

W&S Project No: P18-3241-S1A
W&S File No:

TEST PLOT 8 - NOTES:

SITE PREPARATION

1. THE CONTRACTOR SHALL INSTALL ALL REQUIRED POLLUTION CONTROL DEVICES PRIOR TO CONSTRUCTION AND SHALL BE RESPONSIBLE FOR THEIR MAINTENANCE, REPOSITIONING, AND REMOVAL UPON COMPLETION OF WORK. (SEE SPECIFICATIONS.)
2. DCR SHALL UTILIZE INTERNAL CERTIFIED ARBORIST TO ASSESS AND COORDINATE REMOVAL OF HAZARDOUS LIMBS OR BRANCHES BEFORE WORK BEGINS.
3. INVASIVE/NUISANCE SPECIES REMOVAL SHALL BE PERFORMED ACCORDING TO SPECIFICATIONS. ADDITIONAL INVASIVE/NUISANCE SPECIES NOT FOUND ON THIS LIST MAY EXIST AND SHALL BE REMOVED ACCORDING TO SPECIFICATIONS. DOCUMENTED INVASIVE SPECIES ON THE SITE INCLUDE THE FOLLOWING:

SCIENTIFIC NAME	COMMON NAME
<i>Frangula alnus</i>	GLOSSY BUCKTHORN
<i>Rhamnus cathartica</i>	COMMON BUCKTHORN
<i>Amarpha fruticosa</i>	FALSE INDIGO
<i>Celastrus orbiculatus</i>	ASIATIC BITTERSWEET
<i>Solanum dulcamara</i>	BITTERSWEET NIGHTSHADE
<i>Acer platanoides</i>	NORWAY MAPLE

4. EXISTING NATIVE SPECIES ARE TO REMAIN IN THE RESTORATION AREA. CONTRACTOR SHALL PROVIDE PROTECTIONS TO ENSURE NATIVE SPECIES ARE NOT DISTURBED OR DAMAGED BY INVASIVE REMOVAL AND RESTORATION PLANTING. CONTRACTOR SHALL OBTAIN APPROVAL FROM OWNER'S REPRESENTATIVE WHEN TRANSPLANT OR REMOVAL OF NATIVE SPECIES IS UNAVOIDABLE. ADDITIONAL NATIVE SPECIES NOT FOUND ON THIS LIST MAY EXIST AND SHALL RECEIVE THE SAME PROTECTIONS. DOCUMENTED NATIVE SPECIES INCLUDE THE FOLLOWING:

SCIENTIFIC NAME	COMMON NAME
<i>Ilex glabra</i>	WINTERBERRY

5. CONTRACTOR SHALL NOT DAMAGE RIVERBANKS. RIVERBANKS SHALL BE CHECKED REGULARLY TO ENSURE THEY ARE STRUCTURALLY SOUND AND HAVE NOT BEEN DAMAGED BY RESTORATION WORK.
6. THE EXTENT OF THE RESTORATION AREA MAY VARY FROM THE EXTENT SHOWN ON THE DRAWINGS BASED ON ACTUAL CONSTRUCTION MEANS AND METHODS. THE CONTRACTOR SHALL FIELD VERIFY RESTORATION BOUNDARIES WITH OWNER'S REPRESENTATIVE PRIOR TO CONSTRUCTION.

PLANTING

1. PLANT MATERIAL SHALL BE PROVIDED BY DCR. CONTRACTOR IS RESPONSIBLE FOR INSTALLATION AND MAINTENANCE. REFER TO SPECIFICATIONS.
2. RESTORATION AREAS SHALL BE CHECKED WEEKLY AND AFTER EACH RAINFALL EVENT PRODUCING AT LEAST ONE INCH OF PRECIPITATION TO ENSURE PLANTINGS ARE INTACT AND EROSION AND SEDIMENT STRUCTURES ARE STRUCTURALLY SOUND.
3. AFTER CONTAINER AND PLUG PLANTS HAVE BEEN INSTALLED, SEED ALL DISTURBED AREAS WITH CUSTOM SEED MIX, SEEDED AT SUPPLIER'S SUGGESTED RATES OF THE FOLLOWING SPECIES:

SCIENTIFIC NAME	COMMON NAME
<i>Carex vulpinoidea</i>	FOX SEDGE
<i>Deschampsia flexuosa</i>	COMMON HAIRGRASS
<i>Geranium maculatum</i>	WILD GERANIUM
<i>Juncus tenuis</i>	PATH RUSH

REFER TO SPECIFICATIONS FOR ADDITIONAL PRODUCT INFORMATION AND INSTALLATION INSTRUCTIONS.

PLANTING SCHEDULE

KEY	BOTANIC NAME	COMMON NAME	QUANTITY	SIZE / SPACING
TREES				
OV	OSTRYA VIRGINIANA	AMERICAN HOP HORNBEEAM	1	8' HT., AS SHOWN
SHRUBS				
CL	CLETHRA ALNIFOLIA	SUMMERSWEET CLETHRA	23	3 GAL., 36" O.C.
LB	LINDERA BENZON	NORTHERN SPICEBUSH	13	2 GAL., 48" O.C.
VN	VIBURNUM NUDUM	SMOOTH WITHERROD	13	3' - 4' HT., 48" O.C.
PERENNIALS / FERNS				
DP	DENNSTAEDIA PUNCTILOBULA	HAY - SCENTED FERN	73	1 GAL., 18" O.C.
GM	GERANIUM MACULATUM	WILD GERANIUM	404	PLUG, 6" O.C.
OS	ONOCLEA SENSIBILIS	SENSITIVE FERN	57	1 GAL., 18" O.C.
TC	TIARELLA CORDIFOLIA	FOAM FLOWER	273	PLUG, 6" O.C.
GRASSES / SEDGES / RUSHES				
CA	CAREX APPALACHIA	APPALACHIAN SEDGE	296	PLUG, 6" O.C.
CP	CAREX PENNSYLVANICA	PENNSYLVANIA SEDGE	404	PLUG, 6" O.C.
CV	CAREX VULPINOIDEA	FOX SEDGE	420	PLUG, 6" O.C.

NOTES:

1. ENTIRE LIMIT OF WORK TO OCCUR WITHIN THE WATERTOWN 50' NO BUILD ZONE.
2. ENTIRE LIMIT OF WORK TO OCCUR WITHIN 100' WETLAND BUFFER TO INLAND BANK.
2. ENTIRE LIMIT OF WORK TO OCCUR WITHIN THE 150' WATERTOWN WETLAND BUFFER ZONE.
3. ENTIRE LIMIT OF WORK TO OCCUR WITHIN THE WATERTOWN 100' AND 200' RIVERFRONT AREA.
4. ENTIRE LIMIT OF PROJECT AREA IS LOCATED WITHIN FEMA ZONE AE BASED ON AVAILABLE FEMA FIRM MAPPING.

APPROXIMATE LATITUDE/LONGITUDE OF TEST PLOTS

PLOT NO.	LATITUDE	LONGITUDE
PLOT 8	42.3651	-71.1895

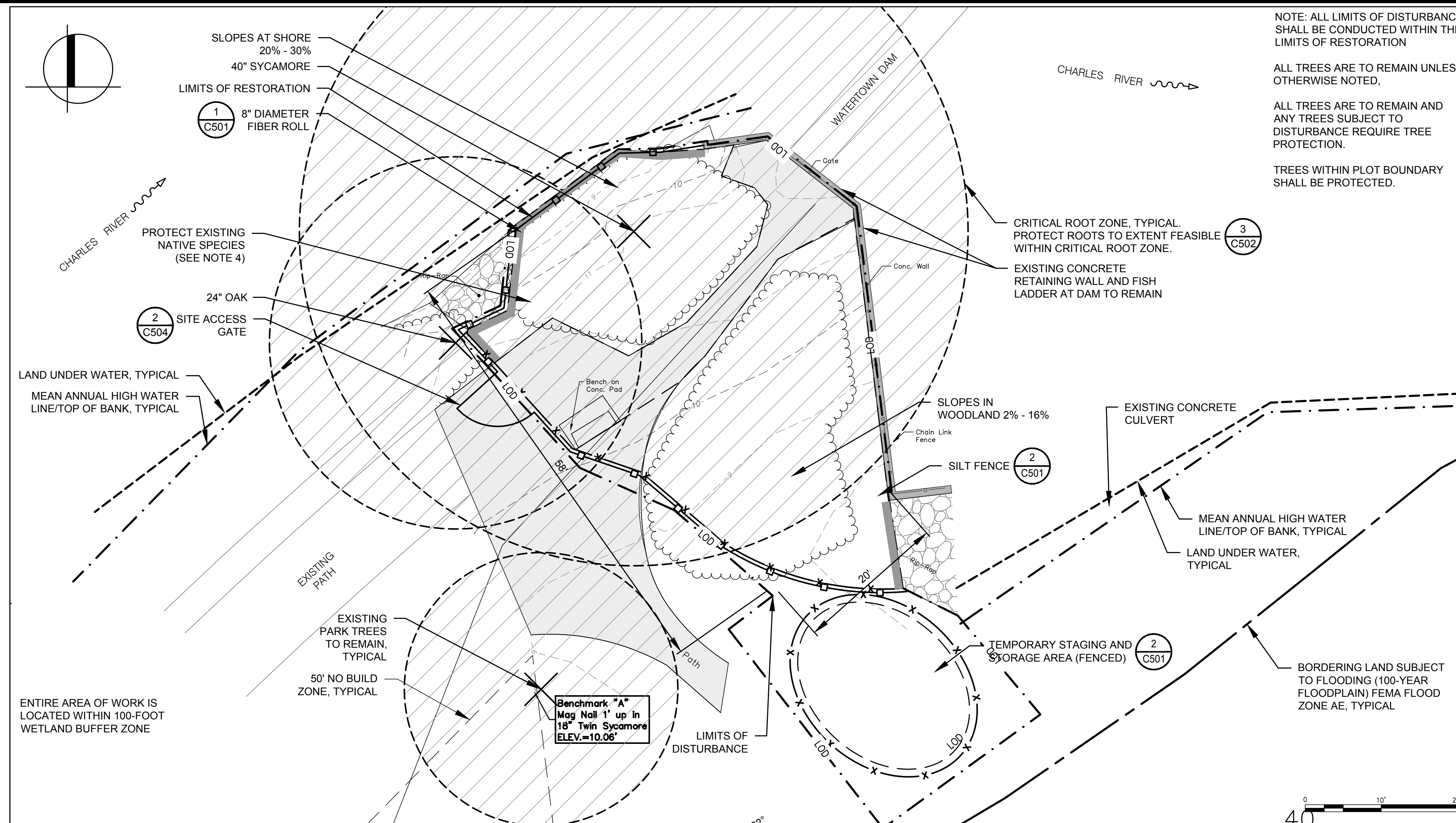

1 TEST PLOT 8 - SITE PREPARATION

SCALE: 1" = 10'

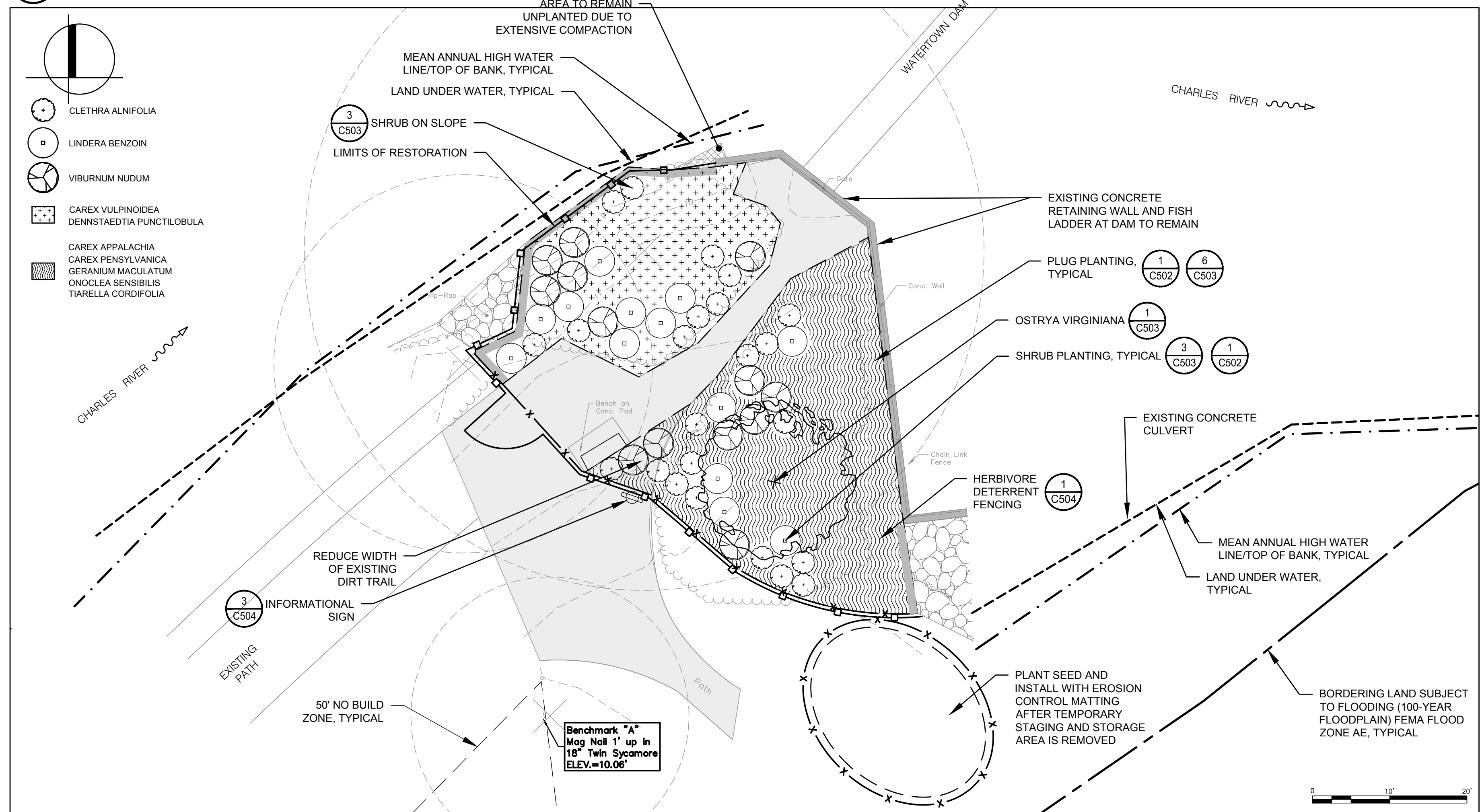

2 TEST PLOT 8 - PLANTING PLAN

SCALE: 1" = 10'

NOTE: ALL LIMITS OF DISTURBANCE SHALL BE CONDUCTED WITHIN THE LIMITS OF RESTORATION
ALL TREES ARE TO REMAIN UNLESS OTHERWISE NOTED.
ALL TREES ARE TO REMAIN AND ANY TREES SUBJECT TO DISTURBANCE REQUIRE TREE PROTECTION.
TREES WITHIN PLOT BOUNDARY SHALL BE PROTECTED.

Project:
MASSACHUSETTS DEPARTMENT OF CONSERVATION AND RECREATION
dcr
Massachusetts
CHARLES RIVER BASIN RIVERBANK VEGETATION MANAGEMENT PLAN

Weston & Sampson

85 Devonshire Street, 3rd Floor,
Boston, MA 02109
617-412-4480 800.SAMPSON
www.westonandsampson.com

Consultants:

Revisions:

No.	Date	Description

Seal:

Issued For:
FOR PERMITTING USE ONLY - NOT FOR CONSTRUCTION

Scale: 1" = 10'
Date: MARCH 2021
Drawn By: RAM
Reviewed By: DPB
Approved By: CFR
W&S Project No: P18-3241-S1A
W&S File No:

Drawing Title:
TEST PLOT 8
Sheet Number:
C108

Consultants:

Revisions:

No.	Date	Description

Seal:

Issued For:

FOR PERMITTING USE ONLY - NOT FOR CONSTRUCTION

Scale: AS NOTED

Date: MARCH 2021

Drawn By: RAM

Reviewed By: DPB

Approved By: CFR

W&S Project No: P18-3241-S1A

W&S File No:

Drawing Title:

EROSION AND SEDIMENT CONTROL DETAILS

Sheet Number:

C501

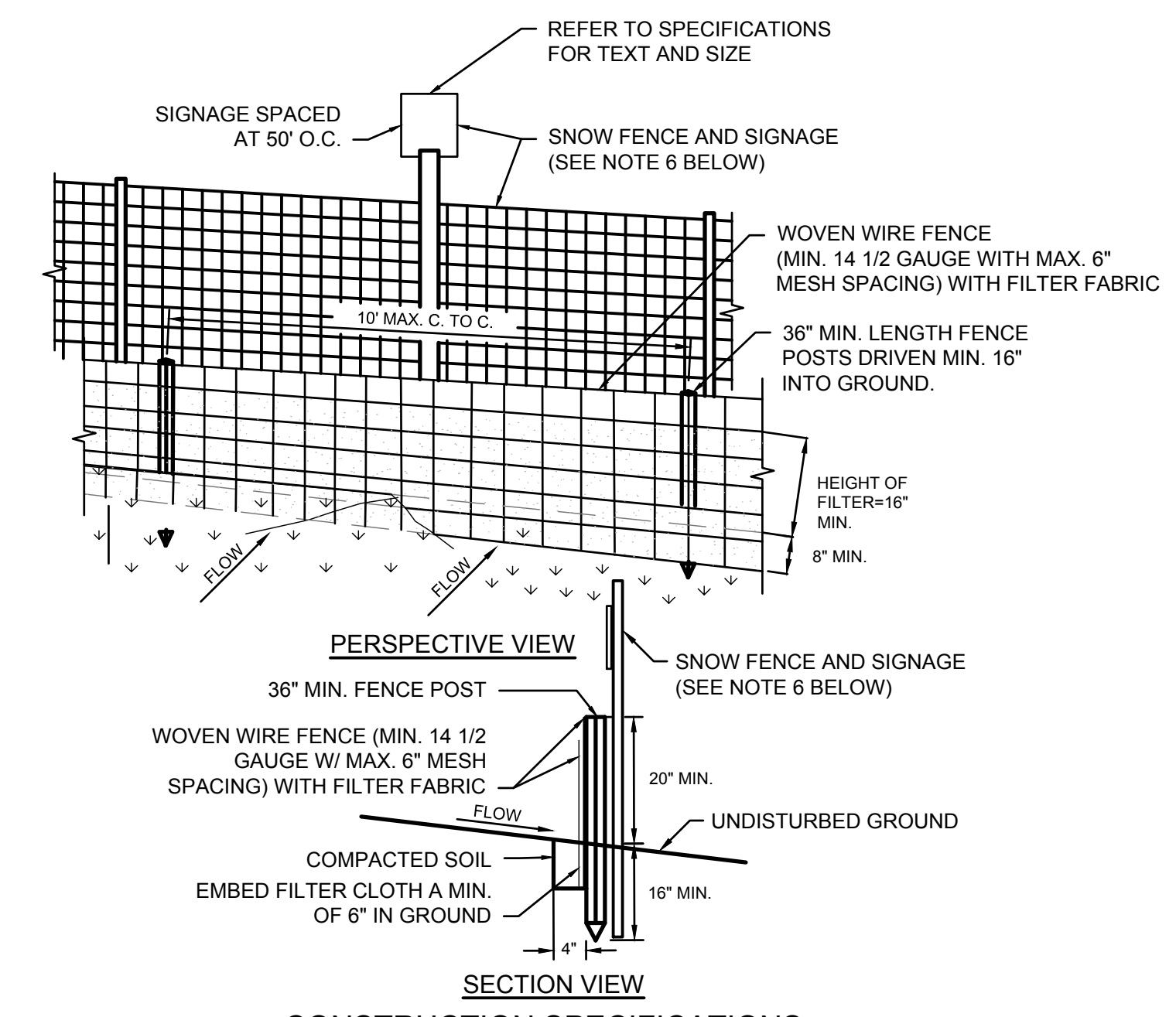

- CONSTRUCTION SPECIFICATIONS**
- WOVEN WIRE FENCE TO BE FASTENED SECURELY TO FENCE POSTS WITH WIRE TIES OR STAPLES. POSTS SHALL BE STEEL EITHER "T" OR "U" TYPE OR HARDWOOD.
 - FILTER FABRIC TO BE FASTENED SECURELY TO WOVEN WIRE FENCE WITH TIES SPACED EVERY 24" AT TOP AND MID SECTION. FENCE SHALL BE WOVEN WIRE, 12 1/2 GAUGE, 6" MAXIMUM MESH OPENING.
 - WHEN TWO SECTIONS OF FILTER FABRIC ADJOIN EACH OTHER THEY SHALL BE OVER-LAPPED BY SIX INCHES AND FOLDED. FILTER CLOTH SHALL BE EITHER FILTER X, MIRAFI 100X, STABILINKA T140N, OR APPROVED EQUIVALENT.
 - PREFABRICATED UNITS SHALL BE GEOFAB, ENVIROFENCE, U.S. SILT & SITE SUPPLY CORPORATION/GETSGO, OR APPROVED EQUIVALENT.
 - MAINTENANCE SHALL BE PERFORMED AS NEEDED AND MATERIAL REMOVED WHEN "BULGES" DEVELOP IN THE SILT FENCE.
 - WHEN SILT FENCE SURROUNDS RESTORATION AREAS, BRIGHT ORANGE SNOW FENCE SHALL BE INSTALLED AROUND PERIMETER AS A PHYSICAL BARRIER. SIGNAGE SPACED AT 50' O.C. SHALL STATE "INVASIVE PLANT MANAGEMENT AREA- HERBICIDE APPLICATION IN PROGRESS - DO NOT DISTURB".
 - REFER TO SPECIFICATIONS FOR ADDITIONAL MATERIAL AND INSTALLATION INFORMATION.

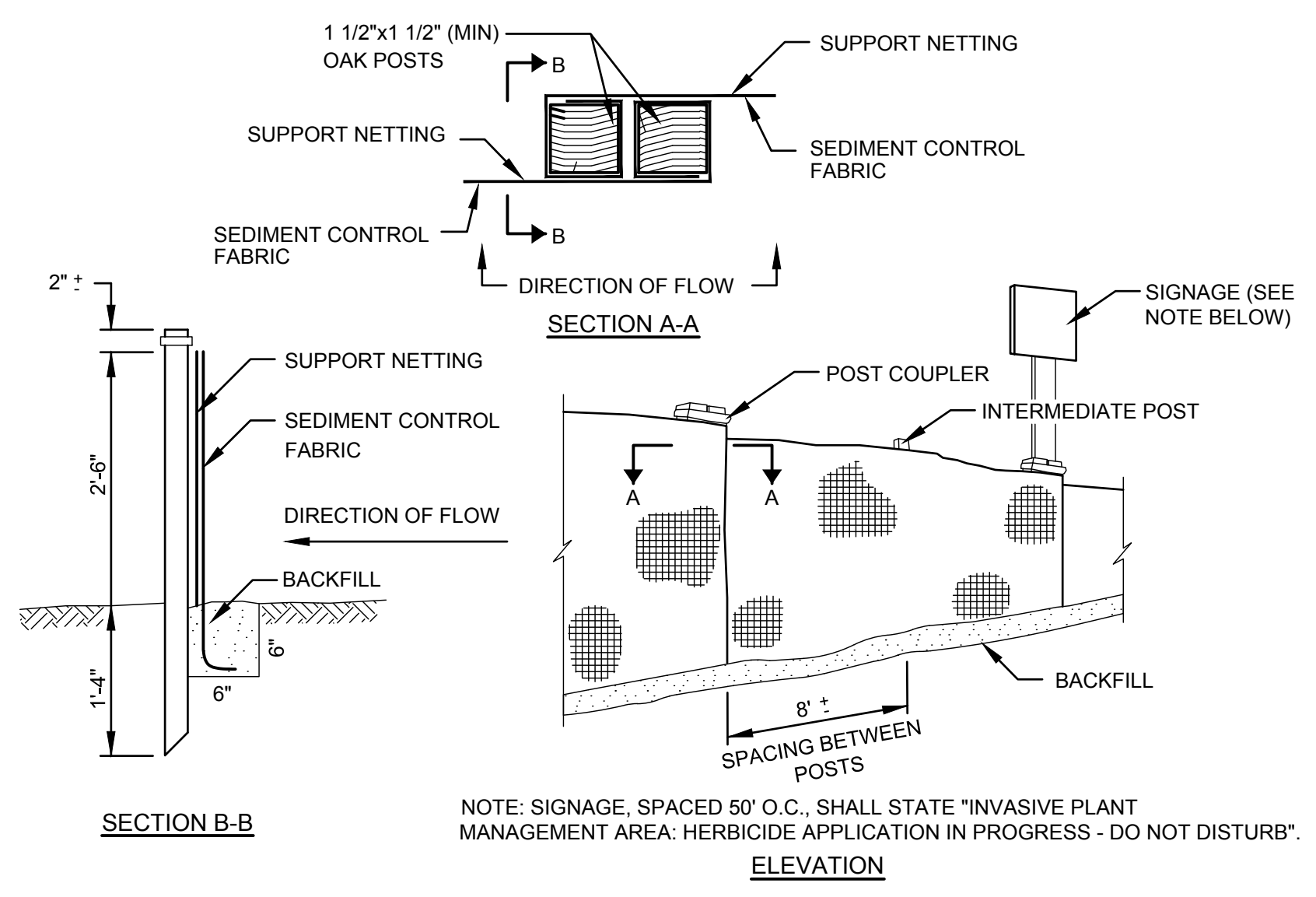

2 SILT FENCE DETAIL
 SCALE: N.T.S.

3 SILT FENCE WITH SNOW FENCE
 SCALE: N.T.S.

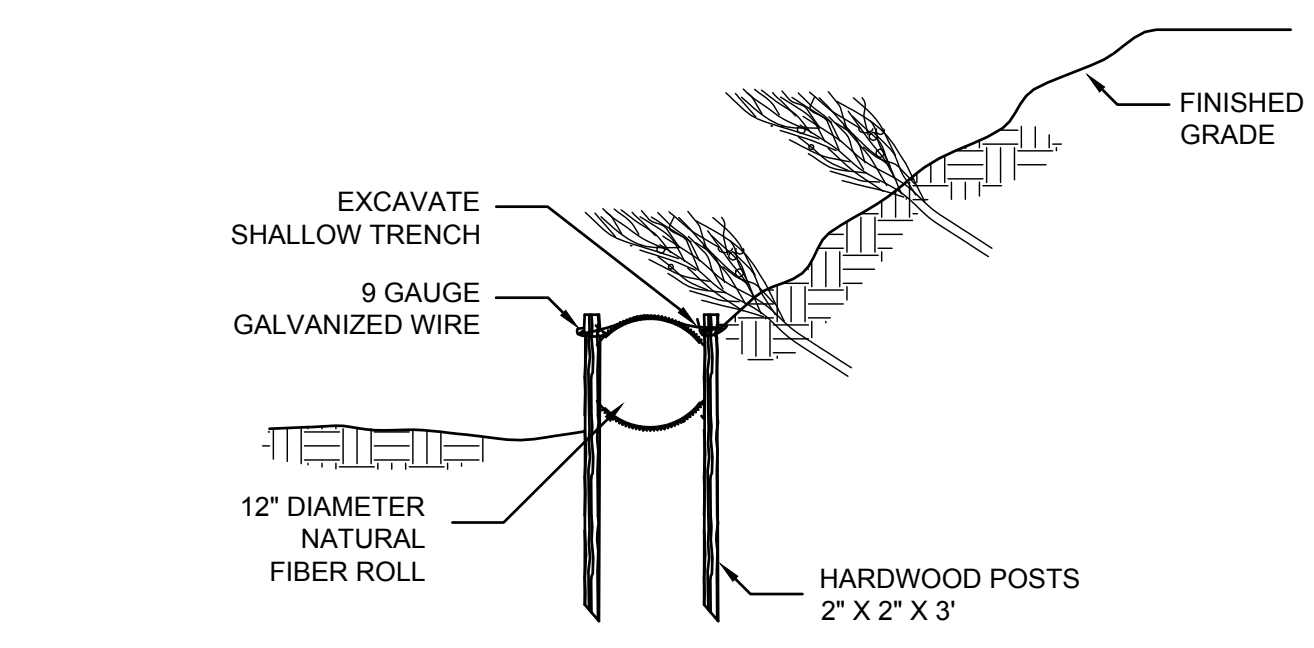

1 FIBER ROLL DETAIL
 SCALE: N.T.S.

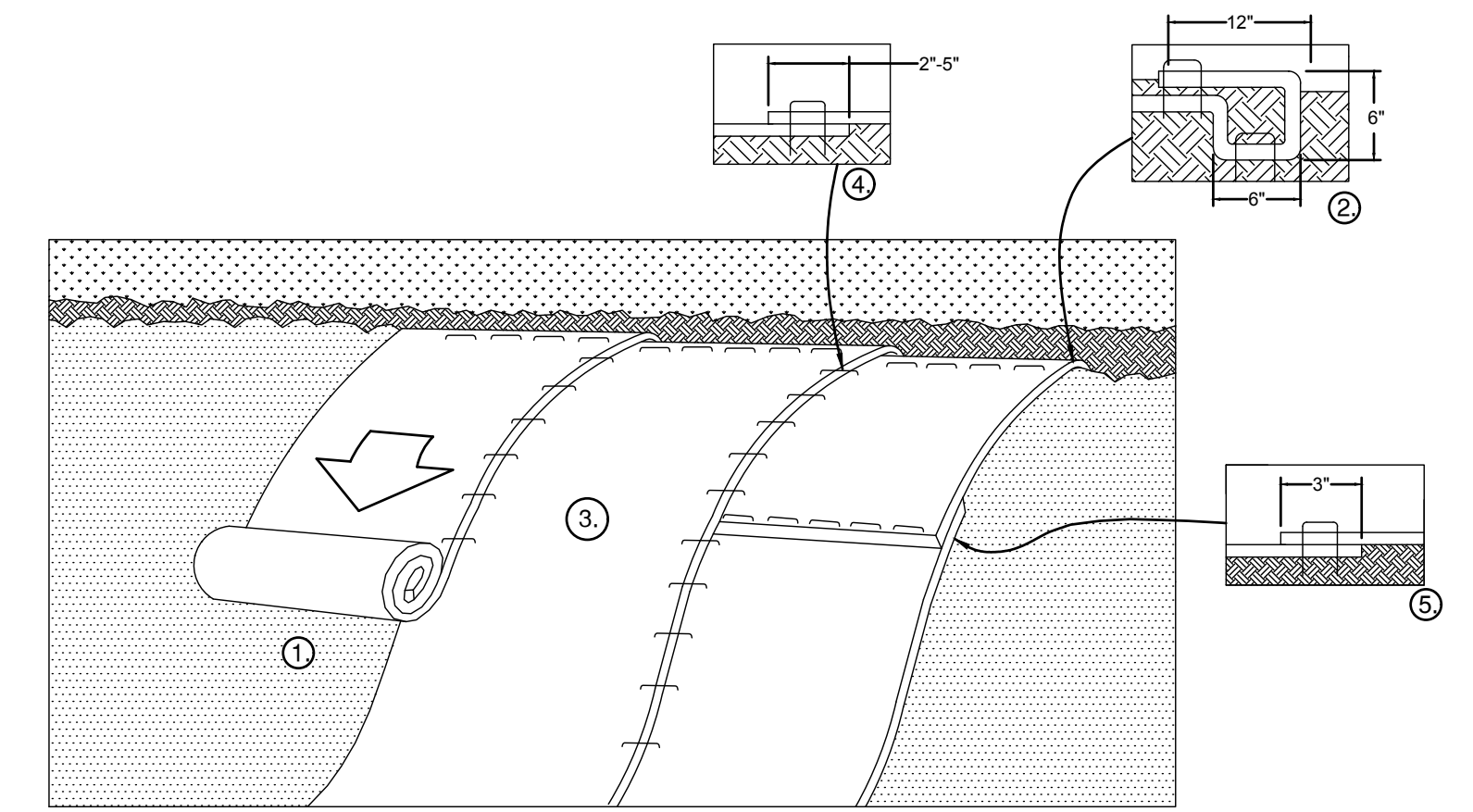

- PREPARE SOIL BEFORE INSTALLING NATURAL FIBER ROLLED EROSION CONTROL PRODUCTS (RECP'S).
 - BEGIN AT THE TOP OF THE SLOPE BY ANCHORING THE RECP'S IN A 6" DEEP X 6" WIDE TRENCH WITH APPROXIMATELY 12" OF RECP'S EXTENDED BEYOND THE UP-SLOPE PORTION OF THE TRENCH. ANCHOR THE RECP'S WITH A ROW OF STAPLES/STAKES APPROXIMATELY 12" APART IN THE BOTTOM OF THE TRENCH. BACKFILL AND COMPACT THE TRENCH AFTER STAPLING. APPLY SEED TO COMPACTED SOIL AND FOLD REMAINING 12" PORTION OF RECP'S BACK OVER SEED AND COMPACTED SOIL. SECURE RECP'S OVER COMPACTED SOIL WITH A ROW OF STAPLES/STAKES SPACED APPROXIMATELY 12" APART ACROSS THE WIDTH OF THE RECP'S.
 - ROLL THE RECP'S DOWN THE SLOPE. RECP'S SHALL UNROLL WITH APPROPRIATE SIDE AGAINST THE SOIL SURFACE. ALL RECP'S MUST BE SECURELY FASTENED TO SOIL SURFACE BY PLACING STAPLES/STAKES IN APPROPRIATE LOCATIONS AS SHOWN IN THE STAPLE PATTERN GUIDE.
 - THE EDGES OF PARALLEL RECP'S MUST BE STAPLED WITH APPROXIMATELY 2" - 5" OVERLAP DEPENDING ON RECP'S TYPE.
 - CONSECUTIVE RECP'S SPLICED DOWN THE SLOPE MUST BE PLACED END OVER END (SHINGLE STYLE) WITH AN APPROXIMATE 3" OVERLAP. STAPLE THROUGH OVERLAPPED AREA, APPROXIMATELY 12" APART ACROSS ENTIRE ON RECP'S TYPE.
- NOTE:
 IN LOOSE SOIL CONDITIONS, THE USE OF STAPLE OR STAKE LENGTHS GREATER THAN 6" MAY BE NECESSARY TO PROPERLY SECURE THE RECP'S.

4 EROSION CONTROL SLOPE STABILIZATION MATTING INSTALLATION DETAIL
 SCALE: N.T.S.

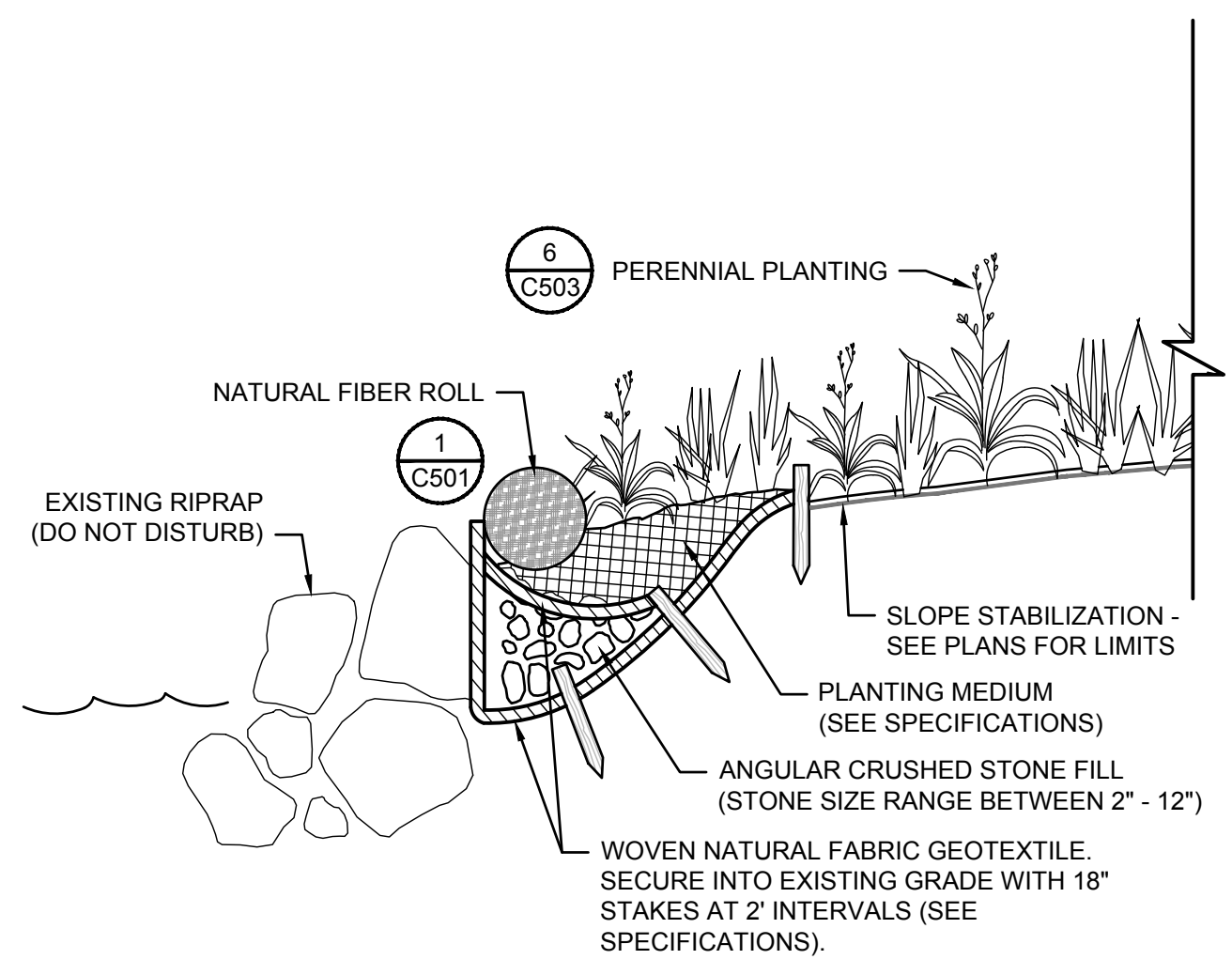

NOTE: ALL WORK TO OCCUR OUTSIDE THE 100-YEAR FLOODPLAIN AND ABOVE THE MEAN ANNUAL HIGH WATER LINE/TOP OF BANK.

5 SLOPE STABILIZATION AT RIPRAP DETAIL
 SCALE: N.T.S.

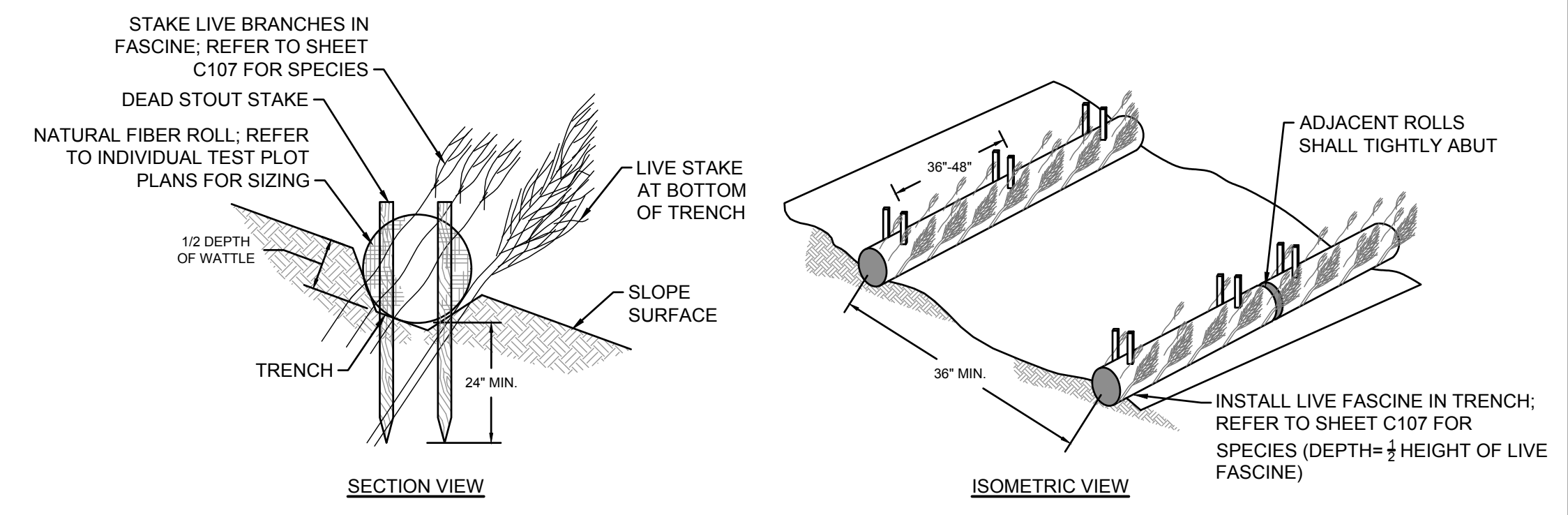

- NOTES:
- BEGIN AT THE LOCATION WHERE THE ROLL IS TO BE INSTALLED BY EXCAVATING A TRENCH WITH A DEPTH OF 1/2 THE HEIGHT OF THE NATURAL FIBER COIR/STRAW ROLL ALONG THE CONTOUR OF THE SLOPE. EXCAVATED SPOIL SHALL BE PLACED UP-SLOPE FROM THE ANCHOR TRENCH.
 - PLACE THE ROLL IN THE TRENCH SO THAT IT CONTOURS TO THE SOIL SURFACE. COMPACT SOIL FROM THE EXCAVATED TRENCH AGAINST THE ROLL ON THE UPHILL SIDE. ADJACENT WATTLES SHALL TIGHTLY ABUT.
 - SECURE THE ROLL WITH (2) 18"-24" STAKES EVERY 3'-4" AND WITH A STAKE ON EACH END. STAKES SHALL BE DRIVEN LEAVING AT LEAST 2"-3" OF STAKE EXTENDING ABOVE THE ROLL. STAKES SHALL BE DRIVEN PERPENDICULAR TO SLOPE FACE.
 - NOTCH THE POSTS AND TIE TOGETHER, ACROSS THE ROLL, WITH BIODEGRADABLE TWINE OR ROPE.
 - PLACE SOIL EXCAVATED FROM THE TRENCH BEHIND THE ROLL AND HAND TAMP. PLANT WITH SUITABLE HERBACEOUS OR WOODY VEGETATION AS NOTED ON PLANS. VEGETATION SHALL BE PLACED IMMEDIATELY ADJACENT TO THE ROLL TO PROMOTE ROOT GROWTH INTO THE FIBER. HERBACEOUS VEGETATION SHALL BE PLANTED INTO THE NATURAL FIBER ROLL AS INDICATED ON THE PLANTING PLANS.

6 LIVE STAKING IN FIBER ROLL
 SCALE: N.T.S.

\\weston\local\W&S\Projects\MA\2021\Charles River Vegetation Management Plan\Phase C Erosion Documents and Construction Drawings\Phase 1 Implementation\CAD\DWG\C501 EROSION AND SEDIMENT CONTROL DETAILS.dwg

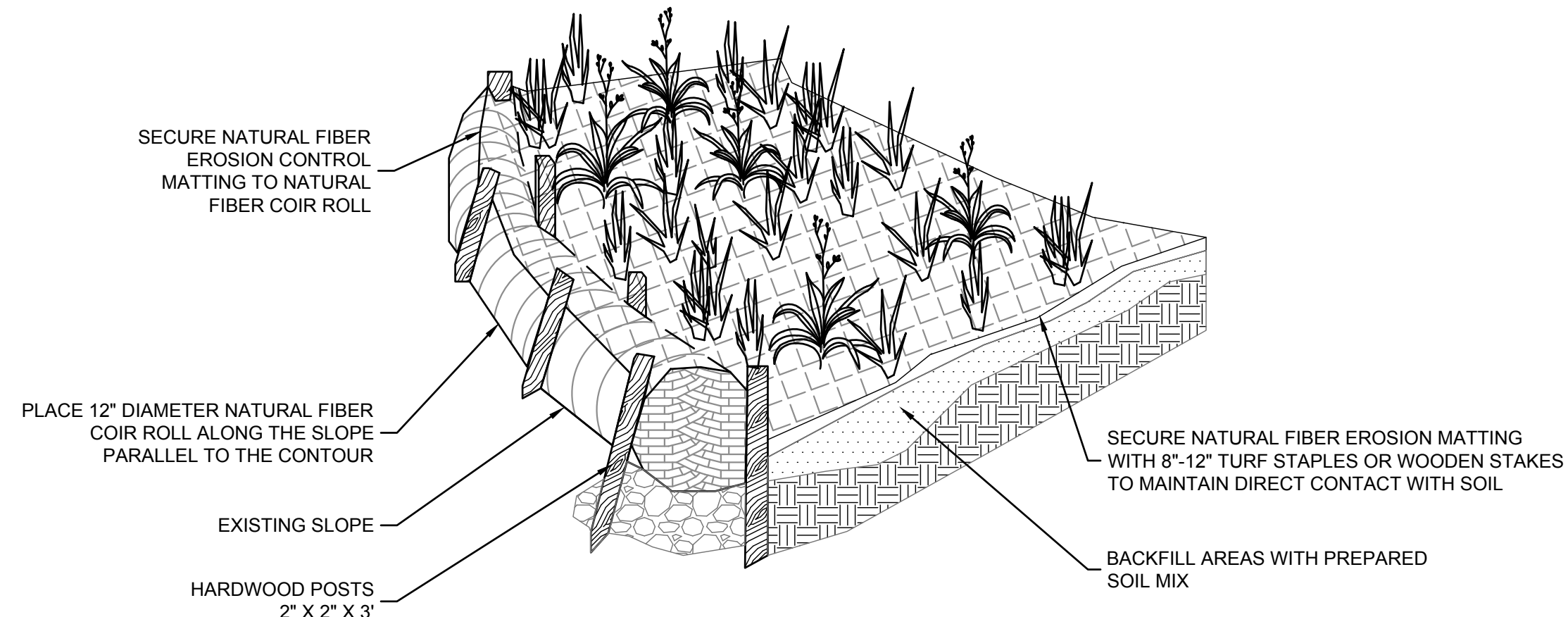

NATURAL FIBER COIR ROLL PLACEMENT

1. EXCAVATE A SHALLOW 4" TRENCH ON SLOPE CONTOUR.
2. PLACE THE ROLL IN THE TRENCH AND ANCHOR WITH 2"X2" POSTS PLACED ON BOTH SIDES OF THE ROLL AND SPACED LATERALLY ON 2' TO 4' CENTERS. TRIM THE TOP OF THE POSTS EVEN WITH THE EDGE OF THE ROLL, IF NECESSARY.
3. NOTCH THE POSTS AND TIE TOGETHER, ACROSS THE ROLL, WITH BIODEGRADABLE TWINE OR ROPE.
4. PLACE SOIL EXCAVATED FROM THE TRENCH BEHIND THE ROLL AND HAND TAMP. VEGETATION SHALL BE PLACED IMMEDIATELY ADJACENT TO THE ROLL TO PROMOTE ROOT GROWTH INTO THE FIBER. HERBACEOUS VEGETATION MAY BE PLANTED INTO THE FIBER ROLL.

1 PLANTED SLOPE STABILIZATION DETAIL
SCALE: N.T.S.

2 NOT USED
SCALE: N.T.S.

PROTECTION OF TREES:

CRITICAL ROOT ZONE PROTECTION NOTES:

PROTECT EXISTING TREES WHICH ARE TO REMAIN FROM AREA CONSTRUCTION OPERATIONS, UTILIZING TREE PROTECTION CRITERIA INCLUDING:

- A. NO CONSTRUCTION EQUIPMENT SHALL BE PERMITTED WITHIN CRITICAL ROOT ZONE.
- B. AFTER PLANT INSTALLATION CONTRACTOR SHALL RESTORE GRADE WITH EXCESS ON-SITE SOIL, WATER WITHIN TEST PLOT, AND PRUNE ANY TREES DISTURBED/DAMAGED BY CONSTRUCTION UNDER THE SUPERVISION OF A CERTIFIED DCR STAFF ARBORIST . REFER TO SPECIFICATIONS.

LANDSCAPE REPLACEMENT:

REMOVE TREES AND OTHER LANDSCAPE FEATURES SCARRED OR DAMAGED BY EQUIPMENT OPERATIONS, AND REPLACE WITH EQUIVALENT, UNDAAGED TREES AND LANDSCAPE FEATURES. OBTAIN OWNER/ARCHITECT'S APPROVAL BEFORE REPLACEMENT. REPLACEMENT OF TREES SHALL OCCUR ON A ONE-TO-ONE BASIS.

3 TREE PROTECTION AND REPLACEMENT NOTES
SCALE: N.T.S.

Consultants:

Revisions:

No.	Date	Description

Seal:

Issued For:
FOR PERMITTING USE ONLY - NOT FOR CONSTRUCTION

Scale: AS NOTED
Date: MARCH 2021
Drawn By: RAM
Reviewed By: DPB
Approved By: CFR
W&S Project No: P18-3241-S1A
W&S File No:

Drawing Title:
PLANTING DETAILS
Sheet Number:
C502

\\lead02local\MSD\Projects\MA\DCR\Charles River Vegetative Management Plan\Phase C Bldg Documents and Construction Drawings\Phase 1 Implementation\CAD\DWG\C502 PLANTING DETAILS.dwg

Consultants:

Revisions:

No.	Date	Description

Seal:

Issued For:
**FOR PERMITTING USE ONLY -
 NOT FOR CONSTRUCTION**

Scale: AS NOTED
 Date: MARCH 2021
 Drawn By: RAM
 Reviewed By: DPB
 Approved By: CFR
 W&S Project No: P18-3241-S1A
 W&S File No:

Drawing Title:
**PLANTING
 DETAILS**
 Sheet Number:
C504

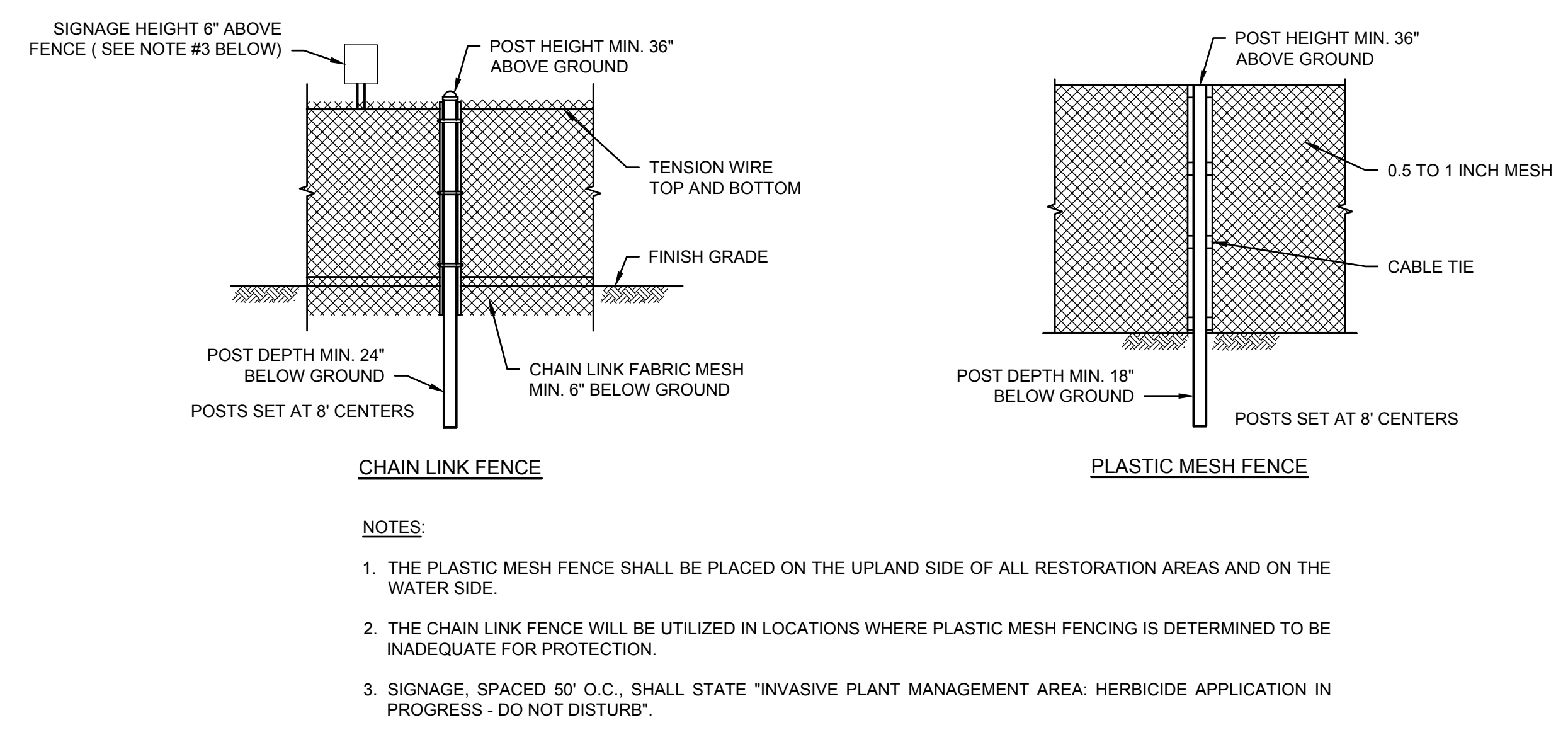

1 HERBIVORE DETERRENT FENCING DETAIL
 SCALE: N.T.S.

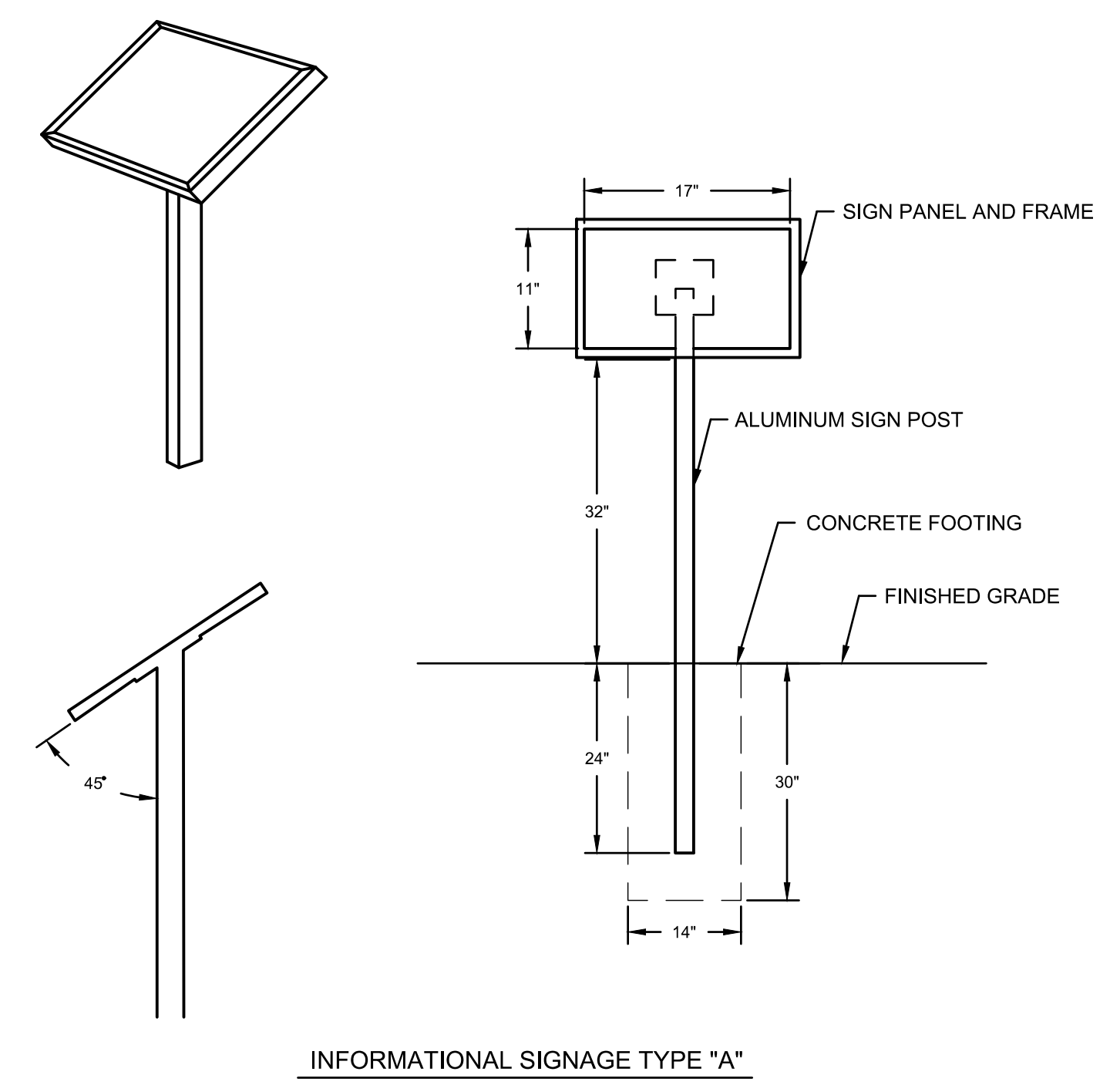

- NOTES:**
1. POSTS TO BE 2" X 4" RECTANGULAR ALUMINUM WITH STAINLESS STEEL HARDWARE.
 2. SIGN PLATE TO BE WELDED AT 45 DEGREES IN ALL INSTANCES.
 3. POSTS TO BE INSTALLED A MINIMUM OF 24" BELOW GRADE IN CONCRETE FOOTING PER MANUFACTURER'S RECOMMENDATIONS.
 4. SIGN POST AND FRAME TO BE TEXTURE POWDER COATED "FOREST GREEN" IN COLOR.
 5. SIGN FRAMES TO ALLOW FOR A PANEL THICKNESS OF .125".
 6. SIGN FRAME WIDTH TO BE 3/4" AND PROVIDE A REMOVABLE TOP RAIL FOR PANEL INSTALLATION.
 7. SIGN FRAME TO ALLOW FOR 11" BY 17" GRAPHIC PANEL.
 8. SIGN MATERIALS TO BE AS MANUFACTURED BY FOSSIL INDUSTRIES INC., PANNIER GRAPHICS, IZONE IMAGING OR APPROVED EQUIVALENT.

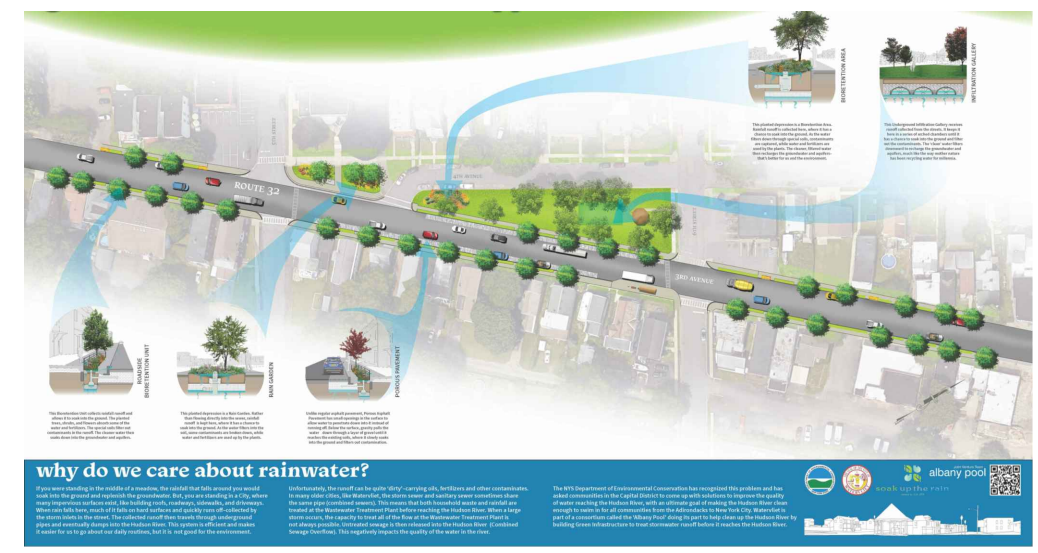

3 INFORMATIONAL SIGN DETAIL
 SCALE: N.T.S.

- NOTES:**
1. CENTER UPRIGHT REQUIRED ON GATE LEAVES 8'-0" AND WIDER. CENTER RAIL REQUIRED ON GATE LEAVES 10'-0" AND HIGHER.
 2. PROVIDE MEANS OF HOLDING GATE(S) OPEN DURING SITE USE HOURS.
 3. PROVIDE ZINC COATED LOCKS WITH MATCHING KEYS FOR ALL GATES TO OWNER.
 4. SUBMIT SHOP DRAWINGS.

SINGLE OR DOUBLE LEAF GATES		
NOM. HEIGHT (H) (WITHOUT BARBED WIRE)	UPRIGHT HEIGHT (U) (ACTUAL DIMENSION)	FRAME HEIGHT (F) (ACTUAL DIMENSION)
3'-0"	2'-10"	2'-8 1/2"

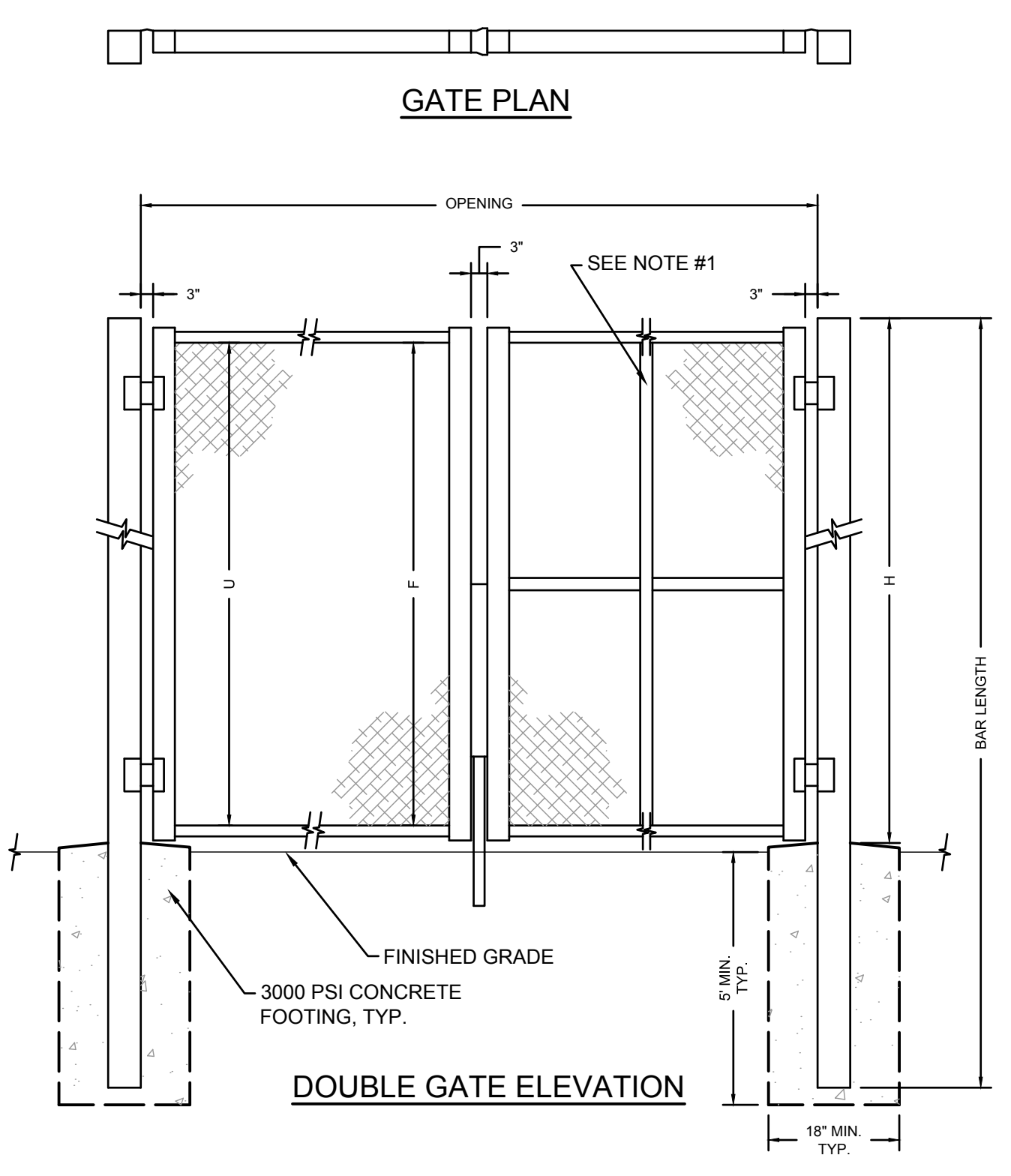

2 CHAIN LINK FENCE GATE DETAIL
 SCALE: N.T.S.

\\lead03\local\W&S\Projects\MA\2021\Charles River Vegetative Management Plan\Phase C Bidding Documents and Construction Drawings\Phase 1 Implementation\CAD\DWG\C504 PLANTING DETAILS.dwg

GOOSE DETERRENT FENCE

1. Perimeter fencing shall be polypropylene goose fence netting, hole size 1.0" x .75", 42-inch wide, as manufactured by Pinelands Nursery and Supply, or approved equal.
2. Hardwood stakes shall be southern yellow pine, full 1.5 inches by 1.5 inches width, by five (5) feet minimum length, free from knots or other defects that can cause splitting.
3. Perimeter fencing shall be secured to hardwood stakes and shall run the perimeter of the restoration area to be protected.

GOOSE DETERRENT STRING AND FLAGGING SYSTEM

1. Flagging shall be reflective and be made from biodegradable or photodegradable material.
2. Biodegradable, sisal-type (coir) twine shall be white, woven or braided, minimum thickness of 1/8".
3. Hardwood stakes shall be southern yellow pine, full 1.5 inches by 1.5 inches width, by five (5) feet minimum length, free from knots or other defects that can cause splitting.

GOOSE DETERRENT FENCE, STRING AND FLAGGING INSTALLATION

- A. The goose deterrent fence shall be installed to protect all planted and seeded areas.
 1. Insert hardwood stakes approximately two (2) feet into the ground, five (5) feet on-center. Install perimeter polypropylene fencing using galvanized staples. End fabric at stake posts once or twice to allow for future access for maintenance.
 2. Span sisal twine over the entire planted/seeded area and staple to the tops of the wood stakes creating a five (5) foot wide pattern. Additional wood stakes should be placed internally at five foot (5') spacing per Detail Drawing.
 3. Place reflective flags every five (5) linear feet, or as directed by Owner's Representative.

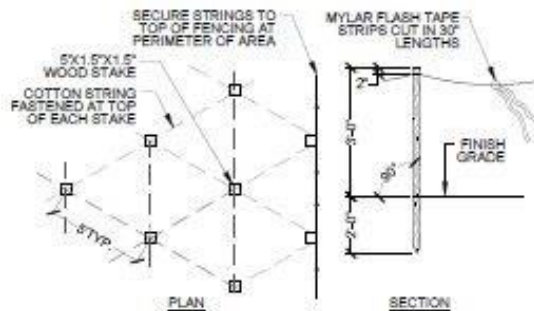

6

GOOSE DETERRENT FENCE

SCALE: NTS

1.1 TREE PROTECTION

- A. All trees to remain shall be protected in accordance with the General Conditions of this Contract and as follows.
- B. As directed by DCR documents, protect trees adjacent to the project site at drip line (rootzone) with construction fencing or chain link fencing as detailed, and as specified in EARTHWORK – Section 02200. Maintain fence while work in the area is ongoing. Remove when directed by DCR.
- C. Damage no plants to remain by burning, by pumping of water, by cutting of live roots or branches, or by any other means. No trees to be saved shall be used for crane stay, guys or other fastenings.
- D. Existing trees to be saved adjacent to the work which have, in the opinion of DCR, become damaged owing to Contractor's negligence, shall be assessed according to the following schedule, and deducted from the Contract amount. All expenses incurred shall be paid by the Contractor without additional cost to DCR.

1.	Trees 6 inches to 12 inches tree	\$20,000 per tree
2.	Trees 12 inches to 18 inches	\$40,000 per tree
3.	Trees 18 inches to 24 inches	\$80,000 per tree
4.	Trees 24 inches and over	\$100,000 per tree

These trees shall be removed, at the direction of DCR, according to the Specification requirements for removals, the stumps grubbed out and removed, and the ground surface repaired. Costs for this removal shall be borne by the Contractor and are not to be included as part of the above schedule.

1.2 GENERAL REQUIREMENTS FOR WORK WITHIN TREE PROTECTION AREAS

- A. The Contractor shall not engage in any construction, maintenance or work activity within tree and plant protection areas. Prohibited activities include: operating, moving or storing equipment; storing supplies or materials; locating temporary facilities including trailers or portable toilets and shall not permit employees to traverse the area to access adjacent areas of the project or use the area for lunch or any other work breaks.
- B. Activity, if any, in tree protection areas must be approved by DCR prior to ALL work. The Contractor must propose proposed remedial work for all tree protection areas after the completion of all work.

- C. All soil removal in the root zones of existing trees shall be done carefully by hand.

1.3 TEMPORARY FENCING REQUIREMENTS

- A. The Contractor must be erect temporary fencing around all areas and approved by DCR before any construction and/or require maintenance works, excavation or other site preparation begins, including repair to existing infrastructure.
- B. Design of all construction fencing must meet current OSHA standards. The Contractor is to be approved prior to the erection of all fencing. Fencing needs to be installed to prevent access from the general public to any construction or specified maintenance works sites/areas.
- C. Placement of all temporary fencing needs approve by DCR prior to installation and the Contractor shall erect it in in a way that appropriately closes off the surrounding area and acknowledges local environmental conditions – access or pathways, stairs, trees or vegetation, weather, equipment, working inside or outside etc.
- D. Placement also needs to recognize the difficulties that individuals with sight impairment face and not place them in danger through unexpected changes in travel routes or placement of obstacles. Placement of any construction fencing is to be approved by DCR prior to work.
- E. When fencing is required in areas by DCR it is the Contractor's responsibility to surround the entire work activity areas and shall maintain the fence in place throughout the entire work activity.
- F. The location plan of any temporary fencing needs to be submitted by Contractor and approved by DCR prior to installation.

APPENDIX F

Invasive Plant Management Details

		Methods of Management				Methods of Disposal	
Category	Invasive Plant Name	Mechanical	Manual	Chemical	Species-Specific Notes		
Non-woody; Fruit and seed	Garlic Mustard (<i>Alliaria petiolata</i>)		-Hand pull (small infestations): do not put pulled plants in piles where roots can stay moist -Mulching: several inches of wood chips -Cutting: repetitive for multiple growing seasons prior to seed set; cut a few inches above soil after flower stalks elongate but before flowers open. Do not cut first year rosettes.		Herbicide application: most effective in fall and/or early spring	<p>Prior to flowering: Depends on scale of infestation</p> <p><u>Small infestation</u></p> <ul style="list-style-type: none"> • Pull or cut plant and leave on site with roots exposed. <p><u>Large infestation</u></p> <ul style="list-style-type: none"> • Pull or cut plant and pile. (You can pile onto or cover with plastic sheeting). • Monitor. Remove any re-sprouting material. <p>During and following flowering Do nothing until the following year or remove flowering heads and bag and let rot.</p> <p><u>Small infestation</u></p> <ul style="list-style-type: none"> • Pull or cut plant and leave on site with roots exposed. <p><u>Large infestation</u></p> <ul style="list-style-type: none"> • Pull or cut plant and pile remaining material. (You can pile onto plastic or cover with plastic sheeting). • Monitor. Remove any re-sprouting material. 	
	Purple Loosestrife (<i>Lythrum salicaria</i>)				Herbicide application: after flowering but before seeds form (June - August)		
	Broad-Leaved Pepperweed (<i>Lepidium latifolium</i>)	-Tilling/mowing (herbicide follow-up required): disk in fall, mow when flowers bud in spring. Allow plants to reach flower bud stage once more before applying herbicide. Further spraying likely needed in future.			- Foliar Application: 1-3% Glyphosate (or approved alternative solution - see notes) directly to foliage prior to seed set		Herbicide Application: should be timed to be at the period when carbohydrate root reserves are at lowest during early flowering or bud stage.
	Greater Celandine (<i>Chelidonium majus</i>)						Safety note: Sap can cause skin irritation. Wear gloves when handling.
	Ground Elder/ Bishops Weed/Goutweed (<i>Aegopodium podagraria</i>)	-Mowing: frequent mowing at short heights, early in year just after plant has reached full leafout -Covering: cover with black plastic sheeting		-Hand pull small/manageable infestations before flowering/seed			Covering: covering after mowing can exhaust energy reserves
	Lesser Celandine (<i>Ficaria verna</i>)						Safety note: Sap can cause skin irritation. Wear gloves when handling.
	Japanese Stiltgrass (<i>Microstegium vimineum</i>)	-Cutting: cut to ground with weed whacker in September, shortly before they produce seed					Herbicide application: 1-2% Fusion/surfactant solution recommended -June to August)
	Horned Poppy (<i>Glaucium flavum</i>)						Hand pull in spring/early summer
	Tyrol Knapweed (<i>Centaurea nigrescens</i>)	-Mowing: mow when plants are in late bud to early bloom stage, 2-4 times a year			- Foliar Application: 3% solution of triclopyr herbicide/water to leaves in early spring or fall		Herbicide application: most effective when combined with hand pulling or mowing
	Spotted Knapweed (<i>Centaurea biebersteinii</i>)						Safety note: Sap of related knapweed can cause skin irritation and tumors. Wear gloves when handling.
	Wild Chervil (<i>Anthriscus sylvestris</i>)	-Mowing: repeatedly before seed set		-Hand pulling -Digging: Dig up seedling plants and root before flowering	- Foliar Application: Broadleaf selective herbicides more effective than nonselective herbicides		Hand pulling: remove entire rosette and taproot Herbicide application: can be enhanced with tilling one week after application, then mid-September seeding of perennial native grasses Safety note: Can cause skin irritation. Wear gloves when handling.
	Leafy Spurge (<i>Euphorbia esula</i>)	-Mowing		-Cutting			Cutting/mowing: seed formation can be prevented by repeated cutting/mowing, but root system will remain viable. Cut plants within 4 inches from ground before seed set and repeat through growing season.
	Giant Hogweed (<i>Heracleum mantegazzianum</i>)	-Plowing: must be done for multiple years; best after mechanical and chemical control		-Hand pulling: (young plants in April-May) -Flower/seed head removal: when flowers are no longer visible but before seeds mature -Cut and Cover- cut plants to ground level and cover soil with black plastic (multiple years)	- Foliar Application: systemic herbicide between April-June and again in July-August		Root removal: cut taproot about 6 inches below ground level in early spring, remove cut pieces, follow up visit 2 weeks after root cut.

		Methods of Management				Methods of Disposal
Category	Invasive Plant Name	Mechanical	Manual	Chemical	Species-Specific Notes	
Non-woody; Fruit, seed, and plant fragment	Common Reed (<i>Phragmites australis</i>)		-Pulling/cutting (not very effective and can lead to spread of propagules) -Hydrogel: cut stalks to ground surface, cover with biodegradable material, place hydrogel and planting medium, and install native vegetation.	Foliar Herbicide Application Cut-Stem Application (isolated stems only)	<u>Pulling/cutting</u> : cut stems below lowest leaf, leaving a stump 6 in or shorter during the flowering stage or boot stage (developed seed head) -typically July <u>Herbicide application</u> : Glyphosate or Imazapyr foliar application during flowering or boot stage.	Small infestation <ul style="list-style-type: none"> • Bag all plant material and let rot. • Never pile and use resulting material as compost. • Burn. Large infestation <ul style="list-style-type: none"> • Remove material to unsuitable habitat (dry, hot and sunny or dry and shaded location) and scatter or pile. • Monitor and remove any sprouting material. • Pile, let dry, and burn.
	Chinese Silvergrass (<i>Miscanthus sinensis</i>)		-Grubbing (small infestations)	Foliar Application: Spot treatments of 2% glyphosate/water solution in late spring or fall	<u>Grubbing</u> : ensure ALL roots are removed	
	Japanese Knotweed (<i>Polygonum cuspidatum</i>)		-Cutting/mowing: Early June or after plant has bloomed out -Wire mesh: install after cutting vegetation flush to ground. Tightly secure and ensure mesh remains tightly affixed to ground surface.	- Foliar application: apply to foliage - Cut-stem: apply concentrated herbicide to exposed stem (thick stems only)		
	Reed Canary Grass (<i>Phalaris arundinacea</i>)	Mowing	-Cutting: Cut as close to the ground as possible to prevent seeding or as part of integrated approach -Shading: Cover with shade cloth and secure tightly; mulching with thick cardboard and wood mulch -Restoration Planting: install native trees and shrub to shade out and compete	- Glyphosate or Imazapyr spot spraying		
	Yellow Iris (<i>Iris pseudacorus</i>)		- Pulling/Digging: Hand pull seedlings; dig up mature plants			
Vine; Non-woody; Fruit and seed	Mugwort (<i>Artemisia vulgaris</i>)	Mowing		- Foliar application: apply glyphosate or triclopyr in late summer or early fall	Mow in early summ and early fall	Prior to flowering: Depends on scale of infestation Small infestation <ul style="list-style-type: none"> • Pull or cut plant and leave on site with roots exposed. Large infestation <ul style="list-style-type: none"> • Pull or cut plant and pile. (You can pile onto or cover with plastic sheeting). • Monitor. Remove any re-sprouting material. During and following flowering Do nothing until the following year or remove flowering heads and bag and let rot. Small infestation <ul style="list-style-type: none"> • Pull or cut plant and leave on site with roots exposed. Large infestation <ul style="list-style-type: none"> • Pull or cut plant and pile remaining material. (You can pile onto plastic or cover with plastic sheeting). • Monitor. Remove any re-sprouting material.
	Mile-A-Minute (<i>Polygonum perfoliatum</i>)		-Hand pulling: when soil is wet prior to fruit formation	Foliar application: apply systemic herbicide in summer before fruiting; use surfactant	Mowing must be repetative to prevent flowering and fruit/seed production	
	Swallow-wort (<i>Cynanchum spp.</i>)		-Digging: Dig up plants so that root crown and rhizomes can be removed, before seeds mature.	- Cut and dab Triclopyr treatment	Mowing can reduce spread, bu must be done every year to be effective. Conduct before seed pods mature.	
	Japanese Hops (<i>Humulus japonicus</i>)	-Mechanized cutting early and throughout growing season	-Hand pulling (small infestations)	- Foliar treatment: ideally two systemic s a year after germination but before extensive growth and again before seed production		
	Porcelain Berry (<i>Ampelopsis brevipedunculata</i>)			- systemic prior to seed set		
	Dodder (<i>Cuscuta spp.</i>)		-Hand pulling: remove if seedlings found before attaching to host -Pruning -Restoration Planting: install non-host species such as grasses and monocots	<u>Herbicide application</u> : Pre-emergent herbicides such as trifluralin applied before seed germination	<u>Pruning</u> : after attachment to host, prune part of host plant 1/4 to 1/8 of an inch below infected area	

		Methods of Management				Methods of Disposal
Category	Invasive Plant Name	Mechanical	Manual	Chemical	Species-Specific Notes	
Vine; Non-woody; Fruit, seed, and plant fragment	Hedge Bindweed (<i>Calystegia sepium</i>)		-Hand pulling: pull young plants 3-4 weeks following germination -Deep cultivation -Covering: cover using landscape fabric or cardboard to prevent light (up to 3 years)	- Fall treatment with glyphosate preferably when there are few flowers but not full bloom	<u>Deep cultivation</u> : use wide sweeps to cut roots and rhizomes 16-18 inches below the surface in dry soil <u>Herbicide application</u> : avoid treatments in time of drought	<p>Prior to fruit/seed ripening <u>Small infestation/Seedlings</u></p> <ul style="list-style-type: none"> • Bag all plant material and let rot. • Never use resulting material as compost. • Burn. <p><u>Larger infestations</u></p> <ul style="list-style-type: none"> • Make a brush pile. • Burn. <p>After fruit/seed is ripe Don't remove from site.</p> <ul style="list-style-type: none"> • Burn. • Make a covered brush pile. • Chip – only after material has fully dried (1 year) and all fruit has dropped from branches. Leave resulting chips on site and monitor.
	Japanese Honeysuckle (<i>Lonicera japonica</i>)		-Hand pulling (small infestations)	Apply a 2% glyphosate or triclopyr solution to leaves from spring through fall. Use 25% solution if using cut-stump method		
	Kudzu (<i>Pueraria montana spp. Lobata</i>)		-Mowing/Digging	Utilize cut-stem treatments with systemic chemicals	<u>Mowing/Digging</u> : Use shovel or pick axe to expose base of root crowns and cut the root below crown with axe or handsaw. Preferably done during hottest parts of summer. <u>Herbicide application</u> : try to remove vines from native plant species prior to application	
	Bittersweet Nightshade (<i>Solanum dulcamara</i>)		-Hand pulling: pull young plants, taking care not to break pieces Cut/cover: can be cut to ground and covered with heavy-duty geotextile fabric for at least 2 years		<u>Herbicide application</u> : must effective when temperatures are between 50-80 °F; and no rain expected; should be applied before native plants emerge. Retreat for 1-2 years may be necessary. Physical removal should only be done after herbicide has been in place long enough for nightshade to be brown and dead.	
Vine; Woody; Fruit, seed, and plant fragment	Hardy Kiwi (<i>Actinidia arguta</i>)		-Cutting: cut large vines in winter/early spring	Foliar or cut-stem herbicide treatment with glyphosate. -Foliar treatment apply directly to leaves with 3% solution (Foliar when cut stem is not possible due to access or too small stem width) This treatment is possible throughout the growing season and usually most effective when flowering/fruitletting.	Herbicide application should be conducted in late summer - early fall	
	Asiatic Bittersweet (<i>Celastrus orbiculatus</i>)	Brush mow large infestations of smaller vines when not overtopping desirable vegetation.	-Hand pulling (small infestations) -Cutting: cut climbing vines near ground	-Cut stem cut vine stems and apply 20%-50% solution immediately -Basal Bark apply concentrated herbicide directly to tree/shrub bark. (fall or early winter)	<u>Herbicide application</u> : apply immediately after cutting, repeat applications preferably in fall and winter. Basal bark method with Garlon 4 can be done if temperatures are above 50 degrees F.	
Vine; Woody; Fruit and seed	Morning Glory/Bindweed (<i>Convolvulus arvensis</i>)		-Hand pulling: pull up to 3-4 weeks following germination -Deep cultivation -Covering: cover using landscape fabric or cardboard (up to 3 years)	- Fall treatment with glyphosate preferably when there are few flowers but not full bloom	<u>Deep cultivation</u> : use wide sweeps to cut roots and rhizomes 16-18 inches below surface in dry soil <u>Herbicide treatment</u> : avoid treatments in times of drought	<p>Prior to fruit/seed ripening <u>Seedlings and small plants</u></p> <ul style="list-style-type: none"> • Pull or cut and leave on site with roots exposed. No special care needed. <p><u>Larger plants</u></p> <ul style="list-style-type: none"> • Use as firewood. • Make a brush pile. • Chip. • Burn. <p>After fruit/seed is ripe Don't remove from site.</p> <ul style="list-style-type: none"> • Burn. • Make a covered brush pile. • Chip once all fruit has dropped from branches. • Leave resulting chips on site and monitor.

		Methods of Management				Methods of Disposal
Category	Invasive Plant Name	Mechanical	Manual	Chemical	Species-Specific Notes	
Woody; Fruit and seed	Autumn Olive (<i>Elaeagnus umbellata</i>)	Mowing (when small enough resprouts are present)	-Hand pulling/digging: pull or dig small seedlings and sprouts -Cutting: remove saplings with weed wrench, cut large plants and dig out stump if possible	Foliar or cut-stem herbicide treatment with glyphosate. -Foliar treatment apply directly to leaves with 3% solution (Foliar when cut stem is not possible due to access or too small stem width) This treatment is possible throughout the growing season and usually most effective when flowering/fruitletting. -Cut stem cut vine stems and apply 20%-50% solution immediately -Basal Bark apply concentrated herbicide directly to tree/shrub bark. This treatment can occur in fall or early winter	Herbicide application to occur in the late growing season (July-September)	Prior to fruit/seed ripening <u>Seedlings and small plants</u> <ul style="list-style-type: none"> • Pull or cut and leave on site with roots exposed. No special care needed. <u>Larger plants</u> <ul style="list-style-type: none"> • Use as firewood. • Make a brush pile. After fruit/seed is ripe Don't remove from site. <ul style="list-style-type: none"> • Burn. • Make a covered brush pile. • Chip once all fruit has dropped from branches. • Leave resulting chips on site and monitor.
	Common Buckthorn (<i>Rhamnus cathartica</i>)				herbicide application in fall or early winter	
	Burning Bush (<i>Euonymus alatus</i>)				<u>Digging</u> : large plants can be dug up with spading fork, pulled with weed wrench, or cut. Stump must be ground out or regrowth clipped.	
	Cypress Spurge (<i>Euphorbia cyparissias</i>)				Hand pulling must be conducted frequently and repeatedly	
	Glossy Buckthorn (<i>Frangula alnus</i>)				Utilize a 25% solution when conducting cut-stem application	
	Shrub Honeysuckles (<i>Lonicera morrowii</i> , <i>L. tatarica</i> , <i>L.x bella</i> , <i>L. maackii</i>)				Herbicide application to occur in late summer during fruiting	
	Japanese Barberry (<i>Berberis thunbergia</i>)				<u>Herbicide application</u> : for trees smaller than 4 inches in diameter: apply Triclopyr mixed with horticultural oil to the bark, a foot from base of trunk in early spring or from June-September -Cut stem treatments should be applied to outer ring of stump	
	Norway Maple (<i>Acer platanoides</i>)				-Hand pulling: pull seedlings from moist soils; dig up larger plants -Girdling: cut through bark and cambium in circle around trunk in the spring -Cutting: cut trunks 2-3' from ground prior to spring sap flow; following cuts may be flush with ground	
	Sycamore Maple (<i>Acer pseudoplatanus</i>)					
Multiflora Rose (<i>Rosa multiflora</i>)	-Mowing (when small with regular mower, when larger with brush mower)	-Hand pulling/cutting (small populations)		Mowing: 3-6 times per year when performed for partial control		
Woody; Fruit, seed, and plant fragment	False Indigo Bush (<i>Amorpha fruticosa</i>)		Hand-pull plants when feasible, dig to remove all roots when possible. Cut and continue to trim regularly.	Foliar or cut-stem with systemic herbicide (glyphosate or approved alternative)	-Repeated defoliation can limit regrowth, but mowing can encourage growth. - <u>Digging</u> : Dig and sever root 3-4 inches below the crown; repeat as necessary	Prior to fruit/seed ripening <u>Seedlings and small plants</u> <ul style="list-style-type: none"> • Pull or cut and leave on site with roots exposed. No special care needed. <u>Larger plants</u> <ul style="list-style-type: none"> • Make a brush pile. • Burn. After fruit/seed is ripe Don't remove from site. <ul style="list-style-type: none"> • Burn. • Make a covered brush pile. • Chip – only after material has fully dried (1 year) and all fruit has dropped from branches. Leave resulting chips on site and monitor.
	Tree of Heaven (<i>Ailanthus altissima</i>)	-Grubbing: for young trees or saplings	Hand pulling: pull or dig very young seedlings Cutting: cut trees while small, in early summer when root reserves are at lowest. Cut regrowth frequently.	-Foliar application apply 3% solution directly to leaves -Cut stem application cut as close to the ground as possible and apply 20%-50% solution as quickly as possible after cutting -Basal Bark application apply concentrated herbicide directly to bark as directed by herbicide label	<u>Herbicide application</u> : Basal bark application is most effective for trees 4-8 inches in diameter. Apply when tree is fully leafed but before it begins to show fall color	
	Large Gray Willow/Rusty Willow (<i>Salix atrocinerea</i> / <i>S. cinerea</i>)	Girdling: cut through bark and cambium layers			<u>Herbicide application</u> : best method for willows is bore and fill application: suitable for willows with branches larger than 50mm in diameter. Cut stem method for smaller trees and branches in summer-fall.	

ARSENAL[®]

SPECIMEN

herbicide

For control of undesirable vegetation growing within specified aquatic sites, forestry sites, pasture/rangeland, and nonagricultural lands; and for establishment and maintenance of wildlife openings, release of unimproved Bermudagrass and Bahiagrass, bareground weed control, and for use under certain paved surfaces

Active Ingredient:

isopropylamine salt of imazapyr: (2-[4,5-dihydro-4-methyl-4-(1-methylethyl)-5-oxo-1*H*-imidazol-2-yl]-3-pyridinecarboxylic acid)* 27.8%

Other Ingredients: 72.2%

Total: 100.0%

* Equivalent to 22.6% 2-[4,5-dihydro-4-methyl-4-(1-methylethyl)-5-oxo-1*H*-imidazol-2-yl]-3-pyridinecarboxylic acid or 2 pounds acid per gallon

EPA Reg. No. 241-346

EPA Est. No.

**KEEP OUT OF REACH OF CHILDREN
CAUTION/PRECAUCIÓN**

Si usted no entiende la etiqueta, busque a alguien para que se la explique a usted en detalle. (If you do not understand the label, find someone to explain it to you in detail.)

See inside for complete **First Aid, Precautionary Statements, Directions For Use, Conditions of Sale and Warranty**, and state-specific crop and/or use site restrictions.

In case of an emergency endangering life or property involving this product, call day or night 1-800-832-HELP (4357).

Net Contents:

BASF Corporation
26 Davis Drive
Research Triangle Park, NC 27709

 **BASF**
The Chemical Company

FIRST AID	
If swallowed	<ul style="list-style-type: none"> • Call a poison control center or doctor immediately for treatment advice. • Have person sip a glass of water if able to swallow. • DO NOT induce vomiting unless told to by a poison control center or doctor. • DO NOT give anything by mouth to an unconscious person.
If in eyes	<ul style="list-style-type: none"> • Hold eyes open and rinse slowly and gently with water for 15 to 20 minutes. • Remove contact lenses, if present, after first 5 minutes; then continue rinsing eyes. • Call a poison control center or doctor for treatment advice.
If on skin or clothing	<ul style="list-style-type: none"> • Take off contaminated clothing. • Rinse skin immediately with plenty of water for 15 to 20 minutes. • Call a poison control center or doctor for treatment advice.
If inhaled	<ul style="list-style-type: none"> • Move person to fresh air. • If person is not breathing, call 911 or an ambulance; then give artificial respiration, preferably by mouth to mouth, if possible. • Call a poison control center or doctor for further treatment advice.
HOTLINE NUMBER	
Have the product container or label with you when calling a poison control center or doctor or going for treatment. You may also contact BASF Corporation for emergency medical treatment information: 1-800-832-HELP (4357).	

Precautionary Statements

Hazards to Humans and Domestic Animals

CAUTION. Harmful if swallowed. Avoid contact with eyes or clothing.

Personal Protective Equipment (PPE)

Some materials that are chemically resistant to this product are listed below. If you want more options, follow the instructions for **Category A** on an EPA chemical-resistance category selection chart.

Mixers, loaders, applicators, and other handlers must wear:

- Long-sleeved shirt and long pants
- Chemical-resistant gloves made of any waterproof material
- Shoes plus socks

Follow manufacturer's instructions for cleaning and maintaining PPE. If no such instructions are given for washables, use detergent and hot water. Keep and wash PPE separately from other laundry. Discard clothing and other absorbent materials that have been drenched or heavily contaminated with this product's concentrate.

DO NOT reuse them.

Engineering Controls

Pilots must use an enclosed cockpit that meets the requirements listed in the Worker Protection Standard (WPS) for agricultural pesticides [40 CFR 170.240(d)(6)].

USER SAFETY RECOMMENDATIONS

Users should:

- Wash hands with plenty of soap and water before eating, drinking, chewing gum, using tobacco, or using the toilet.
- Remove clothing/PPE immediately if pesticide gets inside. Then wash thoroughly and put on clean clothing.
- Remove PPE immediately after handling this product. Wash the outside of gloves before removing. As soon as possible, wash thoroughly and change into clean clothing.

Physical and Chemical Hazards

Spray solutions of **Arsenal® herbicide** must be mixed, stored, and applied only in stainless steel, fiberglass, plastic, and plastic-lined steel containers.

Thoroughly clean application equipment, including landing gear, immediately after use of this product. Prolonged exposure of this product to uncoated steel (except stainless steel) surfaces may result in corrosion and failure of the exposed part. The maintenance of an organic coating (paint) may prevent corrosion.

Environmental Hazards

This product is toxic to plants. Drift and runoff may be hazardous to plants in water adjacent to treated areas.

DO NOT apply to water except as specified in this label. Treatment of aquatic weeds may result in oxygen depletion or loss because of decomposition of dead plants. This oxygen loss may cause suffocation of some aquatic organisms. **DO NOT** treat more than 1/2 of the surface area of the water in a single operation and wait at least 10 to 14 days between treatments. Begin treatment along the shore and proceed outward in bands to allow aquatic organisms to move into untreated areas. **DO NOT** contaminate water when disposing of equipment washwater or rinsate.

This pesticide is toxic to vascular plants and must be used strictly in accordance with the drift precautions on the label.

Directions For Use

It is a violation of federal law to use this product in a manner inconsistent with its labeling.

Arsenal® herbicide must be used only in accordance with the instructions on the label attached to the container. Keep containers closed to avoid spills and contamination.

DO NOT apply this product in a way that will contact workers or other persons, either directly or through drift. Only protected handlers may be in the area during application.

AGRICULTURAL USE REQUIREMENTS

Use this product only in accordance with its labeling and with the Worker Protection Standard, 40 CFR Part 170. This standard contains requirements for the protection of agricultural workers on farms, forests, nurseries, and greenhouses, and handlers of agricultural pesticides. It contains requirements for training, decontamination, notification, and emergency assistance. It also contains specific instructions and exceptions pertaining to the statements on this label about personal protective equipment (PPE) and restricted-entry interval. The requirements in this box only apply to uses of this product that are covered by the Worker Protection Standard.

DO NOT enter or allow worker entry into treated areas during the restricted-entry interval (REI) of **48 hours**.

PPE required for early entry to treated areas that is permitted under the Worker Protection Standard and that involves contact with anything that has been treated, such as plants, soil, or water, is:

- Coveralls
- Shoes plus socks
- Chemical-resistant gloves made of any waterproof material
- Protective eyewear

NONAGRICULTURAL USE REQUIREMENTS

The requirements in this box apply to uses of this product that are NOT within the scope of the Worker Protection Standard (WPS) for agricultural pesticides (40 CFR Part 170). The WPS applies when this product is used to produce agricultural plants on farms, forests, nurseries, or greenhouses.

DO NOT enter or allow others to enter treated areas until sprays have dried.

STORAGE AND DISPOSAL

DO NOT contaminate water, food, or feed by storage or disposal.

Pesticide Storage

DO NOT store below 10° F.

Pesticide Disposal

Wastes resulting from the use of this product must be disposed of on-site or at an approved waste disposal facility.

Container Handling

Nonrefillable Container. DO NOT reuse or refill this

container. Triple rinse or pressure rinse container (or equivalent) promptly after emptying; then offer for recycling, if available, or reconditioning, if appropriate, or puncture and dispose of in a sanitary landfill, or by incineration, or by other procedures approved by state and local authorities.

Triple rinse containers small enough to shake (capacity ≤ 5 gallons) as follows: Empty the remaining contents into application equipment or a mix tank and drain for 10 seconds after the flow begins to drip. Fill the container 1/4 full with water and recap. Shake for 10 seconds. Pour rinsate into application equipment or a mix tank, or store rinsate for later use or disposal. Drain for 10 seconds after the flow begins to drip. Repeat this procedure two more times.

Triple rinse containers too large to shake (capacity > 5 gallons) as follows: Empty the remaining contents into application equipment or a mix tank. Fill the container 1/4 full with water. Replace and tighten closures. Tip container on its side and roll it back and forth, ensuring at least one complete revolution, for 30 seconds. Stand the container on its end and tip it back and forth several times. Turn the container over onto its other end and tip it back and forth several times. Empty the rinsate into application equipment or a mix tank, or store rinsate for later use or disposal. Repeat this procedure two more times.

Pressure rinse as follows: Empty the remaining contents into application equipment or mix tank and continue to drain for 10 seconds after the flow begins to drip. Hold container upside down over application equipment or mix tank, or collect rinsate for later use or disposal. Insert pressure rinsing nozzle in the side of the container and rinse at about 40 PSI for at least 30 seconds. Drain for 10 seconds after the flow begins to drip.

Refillable Container. Refill this container with pesticide only. **DO NOT** reuse this container for any other purpose. Triple rinsing the container before final disposal is the responsibility of the person disposing of the container. Cleaning before refilling is the responsibility of the refiller.

(continued)

STORAGE AND DISPOSAL *(continued)*

Container Handling *(continued)*

Triple rinse as follows: To clean the container before final disposal, empty the remaining contents from this container into application equipment or mix tank. Fill the container about 10% full with water. Agitate vigorously or recirculate water with the pump for 2 minutes. Pour or pump rinsate into application equipment or rinsate collection system. Repeat this rinsing procedure two more times.

When this container is empty, replace the cap and seal all openings that have been opened during use; return the container to the point of purchase or to a designated location. This container must only be refilled with a pesticide product. Prior to refilling, inspect carefully for damage such as cracks, punctures, abrasions, worn-out threads and closure devices. Check for leaks after refilling and before transport. **DO NOT** transport if this container is damaged or leaking. If the container is damaged, or leaking, or obsolete and not returned to the point of purchase or to a designated location, triple rinse emptied container and offer for recycling, if available, or dispose of container in compliance with state and local regulations.

In Case of Emergency

In case of large-scale spillage regarding this product, call:

- CHEMTREC 1-800-424-9300
- BASF Corporation 1-800-832-HELP (4357)

In case of medical emergency regarding this product, call:

- Your local doctor for immediate treatment
- Your local poison control center (hospital)
- BASF Corporation 1-800-832-HELP (4357)

Steps to be taken in case material is released or spilled:

- Dike and contain the spill with inert material (sand, earth, etc.) and transfer liquid and solid diking material to separate containers for disposal.
- Remove contaminated clothing and wash affected skin areas with soap and water.
- Wash clothing before reuse.
- Keep the spill out of all sewers and open bodies of water.

Product Information

Arsenal® herbicide is an aqueous solution to be mixed with water and a surfactant and applied as a spray solution to control undesirable vegetation growing within specified aquatic sites, forestry sites, pasture/rangeland and nonagricultural lands. Aquatic sites consist of standing and flowing water, estuarine/marine, wetland, and riparian areas. Nonagricultural lands include private, public and military lands as follows: uncultivated nonagricultural areas (including airports, highway, railroad and utility rights-of-way, and sewage disposal areas); uncultivated agricultural areas - noncrop producing (including farmyards, fuel

storage areas, fence rows, nonirrigation ditchbanks, and barrier strips); industrial sites - outdoor (including lumberyards, pipeline and tank farms); and natural areas (including wildlife management areas, wildlife openings, wildlife habitats, recreation areas, campgrounds, trailheads, and trails). **Arsenal** may also be used for the release of unimproved Bermudagrass and Bahiagrass, for bareground weed control, and for use under certain paved surfaces.

Herbicidal Activity

Arsenal will control most annual and perennial grass and broadleaf weeds in addition to many brush and vine species with some residual control of undesirable species that germinate above the waterline. **Arsenal** is readily absorbed through emergent leaves and stems and is translocated rapidly throughout the plant with accumulation in the meristematic regions. For maximum activity, weeds should be growing vigorously at the time of application, and the spray solution should include a surfactant (see **Adjuvants** section for specific use directions). Treated plants stop growing soon after spray application. Chlorosis appears first in the newest leaves, and necrosis spreads from this point. In perennials, the herbicide is translocated into and kills underground or submerged storage organs, which prevents regrowth. Chlorosis and tissue necrosis may not be apparent in some plant species until 2 or more weeks after application. Complete kill of plants may not occur for several weeks. **Arsenal** applications are rainfast 1 hour after treatment.

Product Use and Restrictions

Applications may be made for control of undesirable vegetation growing within specified aquatic sites, forestry sites, pasture/rangeland and nonagricultural lands. Aquatic sites consist of standing and flowing water; estuarine/marine, wetland, and riparian areas; for control of most annual and perennial grass weeds, broadleaf weeds, vines and brambles, and hardwood brush and trees for forestry site preparation and release of conifers from woody and herbaceous competition. **Arsenal** may also be used for selective woody and herbaceous weed control in natural regeneration of certain conifers (see **Conifer Release Treatment**).

Nonagricultural lands include private, public and military lands as follows: uncultivated nonagricultural areas (including airports, highway, railroad and utility rights-of-way, and sewage disposal areas); uncultivated agricultural areas - noncrop producing (including farmyards, fuel storage areas, fence rows, nonirrigation ditchbanks, and barrier strips); industrial sites - outdoor (including lumberyards, pipeline and tank farms); and natural areas (including wildlife management areas, wildlife openings, wildlife habitats, recreation areas, campgrounds, trailheads, and trails).

Restrictions and Limitations

- **DO NOT** use on food crops.
- **DO NOT** apply this product within 1/2 mile upstream of an active potable water intake in flowing water (i.e. river, stream, etc.) or within 1/2 mile of an active potable water intake in a standing body of water, such as a lake, pond, or reservoir.
- **DO NOT** apply to water used for irrigation except as described in **Product Use and Restrictions** section of this label.
- Keep from contact with fertilizers, insecticides, fungicides, and seeds.
- **DO NOT** drain or flush equipment on or near desirable trees or other plants, or on areas where their roots may extend, or in locations where the treated soil may be washed or moved into contact with their roots.
- **DO NOT** use on lawns, walks, driveways, tennis courts, or similar areas.
- **DO NOT** side trim desirable vegetation with this product unless severe injury and plant death can be tolerated. Prevent drift of spray to desirable plants.
- Clean application equipment after using this product by thoroughly flushing with water.

Nonagricultural Lands and Forestry Sites

- **DO NOT** apply more than 1.5 lbs acid equivalent (ae) imazapyr (equivalent to 96 fl ozs of **Arsenal® herbicide**) per acre per year.

Pasture/Rangeland Sites

- For spot treatment only.
- **DO NOT** treat more than 1/10 of the available area to be grazed or cut for hay.
- **DO NOT** apply more than 0.75 lb ae imazapyr (equivalent to 48 fl ozs of **Arsenal**) per acre per year.

Aquatic Sites

- **DO NOT** apply more than 1.5 lbs ae imazapyr (equivalent to 96 fl ozs of **Arsenal**) per acre per year.
- **Public waters** - Application of **Arsenal** to water can only be made by federal or state agencies, such as Water Management District personnel, municipal officials, and the U.S. Army Corps of Engineers, or those applicators who are licensed or certified as aquatic pest control applicators and are authorized by the state or local government. Treatment to other than non-native invasive species is limited to only those plants that have been determined to be a nuisance by a federal or state government entity.
- **Permitting** - Consult local state fish and game agency and water control authorities before applying this product to public water. Permits may be required to treat such water.
- **Private waters** - Applications may be made to private waters that are still, such as ponds, lakes, and drainage ditches where there is minimal or no outflow to public waters.
- **Aerial application** - Aerial application to aquatic sites is restricted to helicopter only.

- **Irrigation water** - Application to water used for irrigation that results in **Arsenal** residue greater than 1.0 ppb **MUST NOT** be used for irrigation purposes for 120 days after application or until **Arsenal** residue levels are determined by laboratory analysis or other appropriate means of analysis to be 1.0 ppb or less. When applications are made within 500 feet of an active irrigation intake, **DO NOT** irrigate for at least 24 hours following application to allow for dissipation.

Recreational Use of Water in Treatment Area

There are no restrictions on the use of water in the treatment area for recreational purposes, including swimming and fishing.

Livestock Use of Water in/from Treatment Area

There are no restrictions on livestock consumption of water from the treatment area.

Restrictions for Potable Water Intakes

DO NOT apply **Arsenal** directly to water within 1/2 mile upstream of an active potable water intake in flowing water (i.e. river, stream, etc.) or within 1/2 mile of an active potable water intake in a standing body of water such as a lake, pond, or reservoir. To make aquatic applications around and within 1/2 mile of active potable water intakes, the water intake must be turned off during application and for a minimum of 48 hours after application. These aquatic applications may be made only in cases where there are alternative water sources or holding ponds that would permit turning off an active potable water intake for a minimum period of 48 hours after applications.

NOTE: Existing potable water intakes that are no longer in use, such as those replaced by connections to wells or a municipal water system, are not considered to be active potable water intakes. This restriction does not apply to intermittent, inadvertent overspray of water in terrestrial use sites.

Quiescent or Slow-moving Waters

In lakes and reservoirs, **DO NOT** apply **Arsenal** within 1 mile of an active irrigation water intake during the irrigation season. Applications less than 1 mile from an active irrigation water intake may be made during the off-season if the irrigation intake will remain inactive for a minimum of 120 days after application or until **Arsenal** residue levels are determined by laboratory analysis or other appropriate means of analysis to be 1.0 ppb or less.

Precautions for Avoiding Injury to Nontarget Plants

Untreated desirable plants can be affected by root uptake of **Arsenal**® herbicide from treated soil. Injury or loss of desirable plants may result if **Arsenal** is applied on or near desirable plants, on areas where their roots extend, or in locations where the treated soil may be washed or moved into contact with their roots. When making application along shorelines where desirable plants may be present, use caution to avoid spray contact with their foliage or spray application to the soil in which they are rooted. Shoreline plants that have roots which extend into the water in an area where **Arsenal** has been applied generally will not be adversely affected by uptake of the herbicide from the water.

If treated vegetation is to be removed from the application site, **DO NOT** use the vegetative matter as mulch or compost on or around desirable species.

Managing Off-target Movement

Aerial Application

- Applicators are required to use a coarse or coarser droplet size (ASABE S572) or, if specifically using a spinning atomizer nozzle, applicators are required to use a volume mean diameter (VMD) of 385 microns or greater for release heights below 10 feet. Applicators are required to use a very coarse or coarser droplet size or, if specifically using a spinning atomizer nozzle, applicators are required to use a VMD of 475 microns or greater for release heights above 10 feet. Applicators must consider the effects of nozzle orientation and flight speed when determining droplet size.
- Applicators are required to use upwind swath displacement.
- The boom length must not exceed 60% of the wingspan or 90% of the rotor-blade diameter to reduce spray drift.
- Applications with wind speeds less than 3 mph and with wind speeds greater than 10 mph are prohibited.
- Applications into temperature inversions are prohibited.

Ground Boom Application

- Applicators are required to use a nozzle height below 4 feet above the ground or plant canopy and coarse or coarser droplet size (ASABE S572) or, if specifically using a spinning atomizer nozzle, applicators are required to use a volume mean diameter (VMD) of 385 microns or greater.
- Applications with wind speeds greater than 10 mph are prohibited.
- Applications into temperature inversions are prohibited.

Wind Erosion

Avoid treating powdery, dry, or light sandy soils when conditions are favorable for wind erosion. Under these conditions, the soil surface should first be settled by rainfall or irrigation.

Adjuvants

Postemergence applications of **Arsenal** require the addition of a spray adjuvant. When making aquatic applications, only spray adjuvants approved or appropriate for aquatic use must be used.

Nonionic Surfactant

Use a nonionic surfactant (NIS) at the rate of 0.25% volume/volume (v/v) or higher (see manufacturer's label) of the spray solution (0.25% v/v is equivalent to 1 quart in 100 gallons). For best results, select a nonionic surfactant with a hydrophilic-to-lipophilic balance (HLB) ratio between 12 and 17 with at least 70% surfactant in the formulated product. Alcohol, fatty acid, oil, ethylene glycol, or diethylene glycol should not be considered as surfactants to meet the above requirements.

Methylated Seed Oil or Vegetable Oil Concentrate

Instead of a surfactant, a methylated seed oil (MSO) or vegetable-based seed oil concentrate may be used at the rate of 1.5 to 2 pints per acre. When using spray volumes greater than 30 gallons per acre, mix MSO or vegetable-based seed oil concentrates at a rate of 1% of total spray volume, or alternatively use a nonionic surfactant as described above. Research indicates that these oils may aid in **Arsenal** deposition and uptake by plants under moisture or temperature stress.

Silicone-based Surfactant

See manufacturer's label for specific rates. Silicone-based surfactants may reduce the surface tension of the spray droplet allowing greater spreading on the leaf surface as compared to conventional nonionic surfactants. However, some silicone-based surfactants may dry too quickly, limiting herbicide uptake.

Invert Emulsions

Arsenal can be applied as an invert emulsion. The spray solution results in an invert (water-in-oil) spray emulsion designed to minimize spray drift and spray runoff, resulting in more herbicide on the target foliage. The spray emulsion may be formed in a single tank (batch mixing) or injected (in-line mixing). Consult the invert chemical label for proper mixing directions.

Other

An antifoaming agent, spray pattern indicator, or drift-reducing agent may be applied at the product labeled rate if necessary or desired.

Tank Mixes

Arsenal may be tank mixed with other herbicides.

Consult manufacturer's labels for specific rate restrictions and weeds controlled. Always follow the more restrictive label restrictions and precautions for all products used when making an application involving tank mixes.

Application Methods

Arsenal® herbicide may be selectively applied using low-volume directed application techniques or may be broadcast-applied using ground equipment, watercraft, or aircraft. Aerial applications to aquatic sites must be made by helicopter. In addition, **Arsenal** may also be applied using cut-stump, cut-stem, and frill or girdle treatment techniques within nonagricultural lands, pasture/rangeland, and aquatic sites; see **Aerial Application** and **Ground Application** sections for additional details.

Aerial Application

All precautions must be taken to minimize or eliminate spray drift. Both fixed-wing aircraft and helicopters can be used to apply **Arsenal** on nonagricultural lands, but only helicopters can be used for aquatic applications. **DO NOT** make applications by fixed-wing aircraft or helicopter unless appropriate buffer zones can be maintained to prevent spray drift out of the target area; or when treating open tracts of land, spray drift as a result of fixed-wing aircraft application can be tolerated. Aerial equipment designed to minimize spray drift, such as a helicopter equipped with a **Microfoil™ boom**, **Thru-Valve™ boom**, or raindrop nozzles, must be used and calibrated. Except when applying with a **Microfoil boom**, a drift control agent may be added at the specified label rate. **DO NOT** side trim with **Arsenal** unless death of treated tree can be tolerated.

Uniformly apply the specified amount of **Arsenal** in 2 to 30 gallons of water per acre. A foam-reducing agent may be added at the specified label rate, if needed.

Thoroughly clean application equipment, including landing gear, immediately after use of this product. Prolonged exposure of this product to uncoated steel (except stainless steel) surfaces may result in corrosion and failure of the exposed part. The maintenance of an organic coating (paint) may prevent corrosion.

Ground Application

Foliar Application

Low-volume Foliar Application

Use equipment calibrated to deliver 5 to 20 gallons of spray solution per acre. To prepare the spray solution, thoroughly mix in water 0.5% to 5% **Arsenal** plus surfactant; see the **Adjuvants** section of this label for specific use directions. A foam-reducing agent may be applied at the specified label rate, if needed. For difficult-to-control species (see **Aquatic Weed Control** and **Terrestrial Weed Control** sections for relative susceptibility of weed species), use the higher concentrations of herbicide and/or spray volumes, but **DO NOT** apply more than 3 quarts of **Arsenal** per acre in aquatic sites and nonagricultural lands and 1.5 quarts per acre in pasture/rangeland. Excessive wetting of foliage is not necessary.

For low-volume foliar application, select proper nozzles to avoid overapplication. Proper application is critical to ensure desirable results. Best results are achieved when spray covers the crown and approximately 70 percent of the plant. The use of an even, flat-fan tip with a spray angle of 40 degrees or less will aid in proper deposition.

Appropriate tip sizes include 4004E or 1504E. For a straight-stream and cone pattern, adjustable cone nozzles, such as 5500 X3 or 5500 X4, may be used. Attaching a rollover valve onto a Spraying Systems Model 30 gunjet or other similar spray gun allows for the use of both flat-fan and cone tips on the same gun.

Moisten, but **DO NOT** drench target vegetation causing spray solution to run off.

Low-volume Foliar Application with Backpack. For low-growing species, spray down on the crown, covering crown and penetrating approximately 70% of the plant.

For target species 4 to 8 feet tall, swipe the sides of target vegetation by directing spray to at least 2 sides of the plant in smooth vertical motions from the crown to the bottom. Make sure to cover the crown whenever possible.

For target species over 8 feet tall, lace sides of target vegetation by directing spray to at least 2 sides of the target in smooth zigzag motions from crown to bottom.

Low-volume Foliar Application with Hydraulic Handgun Application Equipment. Use the same technique as described for **Low-volume Foliar Application with Backpack**.

For broadcast application, simulate a gentle rain near the top of target vegetation allowing spray to contact the crown and penetrate the target foliage without falling to the understory. Herbicide spray solution that contacts the understory may result in severe injury or death of plants in the understory.

High-volume Foliar Application

For optimum performance when spraying medium-density to high-density vegetation, use equipment calibrated to deliver up to 100 gallons of spray solution per acre (GPA). Spray solutions exceeding 100 GPA may result in excessive spray runoff, causing increased ground cover injury and injury to desirable species.

To prepare the spray solution, thoroughly mix **Arsenal** in water and add a surfactant; see **Adjuvants** section for specific use directions and rates for surfactants. A foam-reducing agent may be added at the specified label rate, if needed. For difficult-to-control species (see **Aquatic Weed Control** and **Terrestrial Weed Control** sections for relative susceptibility of weed species), use the higher concentrations of herbicide and/or spray volumes, but **DO NOT** apply more than 3 quarts of **Arsenal** per acre in aquatic sites and nonagricultural lands and 1.5 quarts per acre in pasture/rangeland. Uniformly cover the foliage of the vegetation to be controlled, but **DO NOT** apply to runoff. Excessive wetting of foliage is not necessary.

Side Trimming

DO NOT side trim with **Arsenal® herbicide** unless severe injury or death of the treated tree can be tolerated. **Arsenal** is readily translocated and can result in death of the entire tree.

Cut-surface Treatment

Arsenal may be used to control undesirable woody vegetation by applying the **Arsenal** solution to the cambium area of freshly cut stump surfaces or to fresh cuts on the stem of target woody vegetation. Application can be made any time of the year except during periods of heavy sap flow in the spring. **DO NOT** overapply solution causing runoff from the cut surface.

Injury may occur to desirable woody plants if shoots extend from the same root system or their root systems are grafted to those of the treated tree.

Cut-surface Application with Dilute and Concentrate Solutions

Arsenal may be mixed as either a concentrate or dilute solution. The dilute solution may be used for application to the cut surface of the stump or to cuts on the stem of target woody vegetation. Concentrate solutions may be used for application to cuts on the stem. Use of the concentrate solution permits application to fewer cuts on the stem, especially for large-diameter trees. Follow application instructions for proper application techniques for each type of solution.

- To prepare a dilute solution, mix 8 to 12 fluid ounces of **Arsenal** with 1 gallon of water. A surfactant or penetrating agent may improve uptake through partially callused cambiums.
- To prepare a concentrate solution, mix 2 quarts of **Arsenal** with no more than 1 quart of water.

Cut-stump Treatment

Dilute Solution. Spray or brush the solution onto the cambium area of the freshly cut stump surface. Ensure that the solution thoroughly wets the entire cambium area (the wood next to the bark of the stump).

Cut-stem Treatment

(injection, hack-and-squirt)

Dilute Solution. Using standard injection equipment, apply 1 milliliter (mL) of solution at each injection site around the tree with no more than 1-inch intervals between cut edges. Ensure that the injector completely penetrates the bark at each injection site.

Concentrate Solution. Using standard injection equipment, apply 1 mL of solution at each injection site. Make at least 1 injection cut for every 3 inches of diameter at breast height (DBH) on the target tree. For example, a 3-inch DBH tree will receive 1 injection cut, and a 6-inch DBH tree will receive 2 injection cuts. On trees requiring more than 1 injection site, place the injection cuts at approximately equal intervals around the tree.

Frill or Girdle Treatment

Using a hatchet, machete, or chainsaw, make cuts through the bark and completely around the tree to expose the cambium. The cut should angle downward extending into the cambium enough to expose at least 2 growth rings. Using a spray applicator or brush, apply a 25% to 100% solution of **Arsenal** into each cut until thoroughly wet. Avoid applying so much herbicide that runoff to the ground or water occurs.

Forestry Use

Site Preparation Treatment

Arsenal may be used to control labeled grass weeds, broadleaf weeds, vines and brambles, and woody brush and trees on forest sites in advance of regeneration for the following conifer crop species:

Common Name	Scientific Name	Rate (fl ozs/A)
Loblolly pine	<i>Pinus taeda</i>	48 to 80
Loblolly X pitch hybrid		
Longleaf pine	<i>Pinus palustris</i>	
Shortleaf pine	<i>Pinus echinata</i>	
Virginia pine	<i>Pinus virginiana</i>	40 to 64
Slash pine	<i>Pinus elliotii</i>	
Coastal redwood	<i>Sequoia sempervirens</i>	24 to 48
Douglas fir	<i>Pseudotsuga menziesii</i>	
Western hemlock	<i>Tsuga heterophylla</i>	
California red fir	<i>Abies magnifica</i>	24 to 40
California white fir	<i>Abies concolor</i>	
Jack pine	<i>Pinus banksiana</i>	24 to 32
Lodgepole pine	<i>Pinus contorta</i>	
Pitch pine	<i>Pinus rigida</i>	
Ponderosa pine	<i>Pinus ponderosa</i>	
Sugar pine	<i>Pinus lambertiana</i>	
White pine	<i>Pinus strobus</i>	
Black spruce	<i>Picea mariana</i>	
Red spruce	<i>Picea rubens</i>	
White spruce	<i>Picea glauca</i>	

Use the label rate of **Arsenal** per acre applied as a broadcast foliar spray for long-term control of labeled woody plants and residual control of herbaceous weeds. Within 4 to 6 weeks of treatment, grass and other herbaceous weeds will be controlled and may provide fuel to facilitate a site preparation burn, if desired, to control conifers or other species tolerant to the herbicide.

Apply the label rate of **Arsenal** per acre in 5 to 30 gallons total spray solution for helicopter applications or 5 to 100 gallons total spray solution for mechanical ground spray and backpack applications. Use a minimum of 0.5% by volume nonionic surfactant (NIS). Use the higher label rates of **Arsenal** and higher spray volumes when

controlling particularly dense or multilayered canopies of hardwood stands or difficult-to-control species.

In certain cases, tank mixes may be necessary for chemical control of conifers and other species tolerant to **Arsenal**[®] herbicide. Observe all precautions and restrictions on the product labels. Always follow the most restrictive label. Combinations with other products labeled for forest site preparation may kill certain plants such as legumes and blackberry, which are desirable for wildlife habitat.

Where quick initial brownout (deadening of foliage) is desired for burning, apply a tank mixture of 32 fl ozs to 64 fl ozs **Arsenal** with 16 fl ozs to 64 fl ozs glyphosate or 16 fl ozs to 48 fl ozs triclopyr ester per acre. For control of seedling pines, apply 32 fl ozs to 64 fl ozs **Arsenal** with 3 to 4 quarts glyphosate. For site preparation, rates less than 48 fl ozs **Arsenal** will provide suppression of hardwood brush and trees; some resprouting may occur.

DO NOT plant seedlings of black spruce (*Picea mariana*) or white spruce (*Picea glauca*) on sites broadcast-treated with **Arsenal** or into the treated zone of spot or banded applications for 3 months following application or injury may occur.

Herbaceous Weed Control

Use **Arsenal** for selective weeding in the following conifers:

Common Name	Scientific Name	Rate (fl ozs/A)
Loblolly pine	<i>Pinus taeda</i>	12 to 20
Loblolly X pitch hybrid		
Virginia pine	<i>Pinus virginiana</i>	
Longleaf pine ¹	<i>Pinus palustris</i>	8 to 12
Slash pine ¹	<i>Pinus elliottii</i>	
Douglas fir ¹	<i>Pseudotsuga menziesii</i>	

¹ Use of surfactant is not recommended.

Arsenal may be applied as a broadcast treatment, banded over tree rows, or as a directed spray for release of young conifers from herbaceous weeds. To prevent possibility of conifer injury, **DO NOT** apply **Arsenal** when conifers are under stress from drought, disease, animal or winter injury, planting shock, or other stresses reducing conifer vigor. Broadcast applications may be made by helicopter, ground, or backpack sprayer. For difficult-to-control weeds, use the higher labeled rates. Where herbaceous weeds have overtopped conifer seedlings, a nonionic surfactant may be added to improve weed control (except for slash pine, long-leaf pine, and Douglas fir), at a rate not to exceed 0.5% of spray solution volume. Some minor conifer growth inhibition may be observed when herbaceous weed control treatments are made during periods of active conifer growth.

Arsenal may also be applied using backpack or handheld sprayers to control herbaceous weeds around individual conifer seedlings. Mix 0.8 fl oz to 1.2 fl ozs **Arsenal** and 0.2 oz nonionic surfactant per gallon of water. Direct the spray to the weeds and minimize the amount applied to

conifer foliage for best conifer tolerance. Ensure that maximum labeled rates per acre for previously listed crop species are not exceeded.

Arsenal may be tank mixed with sulfometuron to broaden the spectrum of weeds controlled. For loblolly pine, apply 8 fl ozs to 12 fl ozs **Arsenal** plus 1 oz to 2 ozs sulfometuron per acre. The application of **Arsenal** plus sulfometuron on other conifer species may cause growth suppression.

Conifer Release Treatment

Arsenal may be applied as a broadcast or directed spray application for suppression of labeled brush, tree, and herbaceous weed species. Directed spray applications may be made with low-volume applications in conifer stands of all ages by targeting the unwanted vegetation and avoiding direct application to the conifer. Ensure that maximum labeled rates per acre listed for the following crop species are not exceeded.

Broadcast Applications for release of the following conifers from hardwood competition:

Common Name	Scientific Name	Rate (fl ozs/A)
Loblolly pine ³	<i>Pinus taeda</i>	24 to 40
Loblolly X pitch hybrid ³		
Virginia pine ³	<i>Pinus virginiana</i>	
Longleaf pine	<i>Pinus palustris</i>	24 to 32
Pitch pine	<i>Pinus rigida</i>	
Shortleaf pine	<i>Pinus echinata</i>	
Slash pine	<i>Pinus elliottii</i>	
White pine ¹	<i>Pinus strobus</i>	
California red fir	<i>Abies magnifica</i>	16 to 32
California white fir	<i>Abies concolor</i>	
Lodgepole pine ²	<i>Pinus contorta</i>	
Douglas fir ²	<i>Pseudotsuga menziesii</i>	
Jack pine ²	<i>Pinus banksiana</i>	16 to 24
Black spruce ²	<i>Picea mariana</i>	
Red spruce ²	<i>Picea rubens</i>	
White spruce ²	<i>Picea glauca</i>	

¹ **DO NOT** make applications to white pine stands younger than three years old. To minimize potential white pine injury, release treatments should not be made prior to July 15.

² Applications should be made after formation of final conifer resting buds in the fall or height growth inhibition may occur.

³ **Mid-rotation release:** For broadcast applications below the pine canopy in established stands of loblolly pine, loblolly X pitch hybrid, and Virginia pine, use 32 fl ozs to 64 fl ozs product per acre. For mid-rotation release of other species, use rates listed in chart above.

For slash pine and longleaf pine, broadcast release treatments over the top of pines for the purpose of woody plant control must be made after August 15 and only in stands 2 through 5 years old. For applications over the top of slash pine and longleaf pine, DO NOT add surfactant and use lower labeled rates on sandy soils.

Apply the label rate of **Arsenal® herbicide** per acre when making broadcast applications with helicopter or ground spray equipment. Refer to mixing and application instructions for proper spray volumes. A nonionic surfactant may be added at no more than 0.25% by volume.

Use the higher label rates of **Arsenal** when controlling particularly dense stands or difficult-to-control species.

Some minor conifer growth inhibition may be observed when release treatments are made during periods of active conifer growth. To minimize potential conifer height growth inhibition, **DO NOT** make broadcast applications to conifer stands except loblolly pine before the end of the second growing season. To minimize potential conifer height growth inhibition, broadcast release treatments may be made late in the growing season. To prevent possibility of conifer injury, **DO NOT** apply **Arsenal** when conifers are under stress from drought, disease, animal or winter injury, or other stresses reducing conifer vigor.

Arsenal may be used to release loblolly pine seedlings during the first growing season following planting or for one-year-old natural loblolly pine regeneration. For one-year-old loblolly pine release, apply 24 fl ozs to 40 fl ozs per acre of **Arsenal** after July 15. Rates below 32 fl ozs per acre are intended for hardwood growth suppression; expect hardwood resprouting.

Spot Treatment of Undesirable Hardwood Vegetation

Arsenal may be used as a directed foliar or cut-stem application to control undesirable brush and hardwoods in the management of stands of all ages for the conifer species listed in the broadcast application section above. Refer to mixing and application instructions in the directed foliar or cut-stem sections above for proper use rates, equipment, and application techniques. **DO NOT** exceed maximum labeled rates per acre listed for crop species. Cut-stem applications may be used for spot treatment of undesirable hardwoods in Ponderosa pine stands using 24 fl ozs or less of **Arsenal** per acre.

Avoid direct application to desired plant species or injury may occur. Injury may occur to nontarget or desirable hardwoods or conifers if they extend from the same root system, or their root systems are grafted to those of the treated tree, or their roots extend into the treated zone.

Late Rotation Vegetation Control in Western Conifer

In California, the Pacific Northwest and Inland Northwest, broadcast aerial applications of **Arsenal** up to 48 fl ozs per acre are permissible in conifer stands that are targeted for harvesting the year following treatment. Use minimum spray volume of 15 gallons per acre. Significant conifer injury or mortality must be expected. **DO NOT** use this treatment if conifer injury or mortality cannot be tolerated.

Bag and Spray Application for Conifer Release

In Douglas fir and Ponderosa pine stands, broadcast applications of **Arsenal** up to 32 fl ozs per acre are permissible when the trees are covered by bags prior to the application. The bags must prevent the spray mix from contacting the conifer foliage. On sites with coarse textured soils (e.g. decomposed granite, pumice, sandy or rocky sites) or low levels of soil organic matter (generally 5% or less), significant conifer growth inhibition and mortality is possible. **DO NOT** use this treatment on these types of sites if conifer growth inhibition and mortality cannot be tolerated.

Nonagricultural Land Use

Arsenal may be used for woody and herbaceous weed control in nonagricultural lands including private, public and military lands as follows: uncultivated nonagricultural areas (including airports, highway, railroad and utility rights-of-way, and sewage disposal areas); uncultivated agricultural areas - noncrop producing (including farmyards, fuel storage areas, fence rows, nonirrigation ditchbanks, and barrier strips); industrial sites - outdoor (including lumberyards, pipeline and tank farms); and natural areas (including wildlife management areas, wildlife openings, wildlife habitats, recreation areas, campgrounds, trailheads, and trails).

Applications to nonagricultural lands are not applicable to treatment of commercial timber or other plants grown for sale or other commercial use, or for commercial seed production, or for research purposes.

Brush Control

Use the specified rate of **Arsenal** with the preferred application technique for control of undesirable brush.

Tank Mixes and Application Rates for Low-volume Foliar Brush Control*

Target Vegetation	Arsenal Rate (% by volume)	Tank Mix
Mixed hardwoods without elm, locust, or pine	1.0 to 1.5	Surfactant
Mixed hardwoods containing elm, locust, and pine	0.5 to 1.0	Accord® at 2% to 3% by volume plus surfactant
Mixed hardwoods with locust and pine but no elm		Krenite® at 2% to 5% by volume plus surfactant
Mixed hardwoods with locust and elm but no pine		Escort® at 2 ozs/A or 2.3 grams/gal plus surfactant

* Tank mixes with 2,4-D or products containing 2,4-D have resulted in reduced **Arsenal** efficacy.

Backpack and Handheld Spray Mixing Guide

% solution	Product per gallon of mix (fl ozs)	Product per 4-gallon backpack (fl ozs)
0.25	0.3	1.3
0.5	0.6	2.6
1.0	1.3	5.1
2.0	2.6	10.2
3.0	3.8	15.4
5.0	6.4	25.6

Measuring Chart

128 fluid ounces	=	1 gallon
16 fluid ounces	=	1 pint
8 pints	=	1 gallon
4 quarts	=	1 gallon
2 pints	=	1 quart

Selective Control of Undesirable Weeds in Unimproved Bermudagrass and Bahiagrass

Arsenal[®] herbicide may be used on unimproved Bermudagrass and Bahiagrass turf such as roadsides, utility rights-of-way, and other nonagricultural lands. **Arsenal** application on established common and coastal Bermudagrass and Bahiagrass provides control of labeled broadleaf and grass weeds. Competition from these weeds is eliminated, releasing the Bermudagrass and Bahiagrass. Treatment of Bermudagrass with **Arsenal** results in a compacted growth habit and seedhead inhibition.

Uniformly apply with properly calibrated ground equipment using at least 10 gallons of water per acre.

Temporary yellowing of grass may occur when treatment is made after growth begins.

- **DO NOT** add surfactant in excess of the specified rate (1 fl oz per 25 gallons of spray solution).
- **DO NOT APPLY** to grass during its first growing season.
- **DO NOT APPLY** to grass under stress from drought, disease, insects, or other causes.

Dosage Rate and Timing

Bermudagrass. Apply **Arsenal** at 6 fl ozs to 12 fl ozs per acre when Bermudagrass is dormant. Apply **Arsenal** at 6 fl ozs to 8 fl ozs per acre after Bermudagrass has reached full greenup. Applications made during greenup will delay greenup. Include a surfactant in the spray solution.

For additional preemergence control of annual grass and small-seeded broadleaf weeds, add **Pendulum**[®] **AquaCap**[™] herbicide at the rate of 3.1 to 6.3 pints per acre. Consult the **Pendulum AquaCap** label for weeds controlled and for other use directions and precautions.

For control of Johnsongrass in Bermudagrass turf, apply **Arsenal** at 8 fl ozs per acre, plus **Roundup**[®] herbicide at 12 fl ozs per acre, plus surfactant. For additional control of broadleaves and vines, **Garlon**[®] **3A** herbicide may be added to the above mix at 1 to 2 pints per acre. Observe all precautions and restrictions on the **Garlon 3A** and **Roundup** labels.

Bahiagrass. Apply **Arsenal** at 4 fl ozs to 8 fl ozs per acre when Bahiagrass is dormant or after grass has initiated greenup but has not exceeded 25% greenup. Include a surfactant in the spray solution; see **Adjuvants** section for specific use directions for surfactants.

Weeds Controlled in Unimproved Bermudagrass and Bahiagrass

Common Name	Scientific Name
Bedstraw*	<i>Galium</i> spp.
Bishopweed*	<i>Ptilimnium capillaceum</i>
Buttercup*	<i>Ranunculus parviflorus</i>
Carolina geranium	<i>Geranium carolinianum</i>
Fescue	<i>Festuca</i> spp.
Foxtail	<i>Setaria</i> spp.
Little barley	<i>Hordeum pusillum</i>
Seedling Johnsongrass	<i>Sorghum halepense</i>
White clover	<i>Trifolium repens</i>
Wild carrot	<i>Daucus carota</i>
Yellow woodsorrel	<i>Oxalis stricta</i>

* Use not permitted in California unless otherwise directed by supplemental labeling.

Grass Growth and Seedhead Suppression

Arsenal may be used to suppress growth and seedhead development of certain turfgrass in unimproved areas. When **Arsenal** is applied to desirable turf, it may result in temporary turf damage and/or discoloration. Effects to the desirable turf may vary with environmental conditions. For optimum performance, apply before culm elongation. Applications may be made before or after mowing. If applied before mowing, allow at least 3 days of active growth before mowing. If applied after mowing, allow sufficient time for grass to recover before applying this product or injury may be amplified.

DO NOT APPLY to turf under stress (drought, cold, insect damage, etc.) or severe injury or death may occur.

Bermudagrass. Apply **Arsenal** at 6 fl ozs to 8 fl ozs per acre from early greenup to before seedhead initiation. **DO NOT** add surfactant for this application.

Cool-season Unimproved Turf. Apply **Arsenal** at 2 fl ozs per acre plus 0.25% nonionic surfactant. For increased suppression, **Arsenal** may be tank mixed with products such as **Embark**[®] growth regulator (8 fl ozs per acre). Tank mixes may increase injury to desired turf. Consult each product label for labeled turf species and other use directions and precautions. Tank mixes with 2,4-D or products containing 2,4-D may decrease the effectiveness of **Arsenal**.

Total Vegetation Control where Bare Ground is Desired

Arsenal[®] herbicide is an effective herbicide for pre-emergence or postemergence control of many annual and perennial broadleaf and grass weeds where bare ground is desired. **Arsenal** is particularly effective on hard-to-control perennial grasses. **Arsenal** at 1.5 to 6 pints per acre can be used alone or in tank mix with herbicides approved for use in bare ground. The degree and duration of control are dependent on **Arsenal** rate used, tank mix partner, volume of carrier, soil texture, rainfall, and other conditions.

Consult manufacturer's labels for specific rates and weeds controlled. Always follow the more restrictive label restrictions and precautions for all products used when making an application involving tank mixes.

Applications of **Arsenal** may be made any time of the year. Use equipment calibrated to deliver desired gallons per acre spray volume and uniformly distribute the spray pattern over the treated area.

Postemergence Application. Always use a spray adjuvant (see **Adjuvants** section of this label) when making a postemergence application. For optimum performance on tough-to-control annual grass weeds, apply **Arsenal** at a total volume of 100 gallons per acre or less. For quicker burndown or brownout of target weeds, **Arsenal** may be tank mixed with **Roundup**[®] herbicide. Tank mixes with 2,4-D or products containing 2,4-D may reduce the performance of **Arsenal**. Always follow the most restrictive label restrictions and precautions for all products used when tank mixing.

Spot Treatment. **Arsenal** may be used as a follow-up treatment to control escapes or weed encroachment in a bareground situation. To prepare the spray solution, thoroughly mix in each gallon of water 0.5% to 5% **Arsenal** plus an adjuvant. For increased burndown, include **Roundup** as a tank mixture. For added residual weed control or to increase the weed spectrum, add **Pendulum**[®] **AquaCap**[™] herbicide, **Overdrive**[®] herbicide, or diuron. Always follow the most restrictive label restrictions and precautions for all products used when tank mixing.

Control of Undesirable Weeds under Paved Surfaces

Arsenal can be used under asphalt, pond liners, and other paved areas, **ONLY** in industrial sites or where the pavement has a suitable barrier along the perimeter that prevents encroachment of roots of desirable plants.

Use **Arsenal** only where the area to be treated has been prepared according to good construction practices. If rhizomes, stolons, tubers, or other vegetative plant parts are present in the site, remove them by scalping with a grader blade to a depth sufficient to ensure their complete removal.

Follow **Arsenal** applications with paving as soon as possible. **DO NOT** apply where **Arsenal** may contact the roots of desirable trees or other plants.

Arsenal is not to be used under pavement on residential properties, such as driveways or parking lots, or for use in recreational areas, such as under bike or jogging paths, golf cart paths, or tennis courts, or where landscape plantings could be anticipated.

Injury or death of desirable plants may result if **Arsenal** is applied where roots are present or where roots may extend into the treated area. Roots of trees and shrubs may extend a considerable distance beyond the branch extremities (drip line).

Apply to the soil surface only when final grade is established. **DO NOT** move soil following **Arsenal** application.

Apply **Arsenal** in sufficient water (at least 100 gals per acre) to ensure thorough and uniform wetting of the soil surface, including shoulder areas. Add **Arsenal** at a rate of 3 quarts per acre (2.2 fluid ounces per 1000 square feet) to clean water in the spray tank during filling operation. Agitate before spraying.

If soil is not moist before treatment, incorporation of **Arsenal** is needed for herbicide activation. Incorporate **Arsenal** into the soil to a depth of 4 to 6 inches using a rototiller or disc. Rainfall or irrigation of 1 inch will also provide uniform incorporation. **DO NOT** allow treated soil to wash or move into untreated areas.

Spot Treatment and Crack-and-crevice Treatment

Use **Arsenal** as an initial or follow-up treatment to control weed escapes or weed encroachment in a bareground situation, including cracks and crevices in paved surfaces such as roadways, runways, and parking areas.

Grass Pasture and Rangeland Spot Treatment Weed Control

For control of undesirable vegetation in grass pasture and rangeland, **Arsenal** may be applied as a spot treatment at a rate of 2 to 48 fluid ounces of product per treated acre using any of the described ground application methods. Spot applications to grass pasture and rangeland may not exceed more than 1/10 of the area to be grazed or cut for hay. See appropriate sections of this label for specific use directions for the application method and vegetation control desired. **DO NOT** apply more than 48 fluid ounces of **Arsenal** per acre per year.

Grazing and Haying Restrictions

- There are no grazing restrictions following **Arsenal** application.
- **DO NOT** cut forage grass for hay for 7 days after **Arsenal** application.

Rangeland Use Instructions

Arsenal[®] herbicide may be applied to rangeland for control of undesirable vegetation to achieve one or more of the following vegetation management objectives:

- Control of undesirable (nonnative, invasive, and noxious) plant species
- Control of undesirable vegetation to aid in the establishment of desirable rangeland plant species
- Control of undesirable vegetation to aid in the establishment of desirable rangeland vegetation following a fire
- Control of undesirable vegetation to reduce wildfire fuel
- Release of existing desirable rangeland plant communities from the competitive pressure of undesirable plant species
- Control of undesirable vegetation for wildlife habitat improvement

To ensure the protection of threatened and endangered plants when applying **Arsenal** to rangeland:

- Federal agencies must follow NEPA regulations to ensure protection of threatened and endangered plants.
- State agencies must work with the Fish and Wildlife Service or the Service's designated state conservation agency to ensure protection of threatened and endangered plants.
- Other organizations or individuals must operate under a habitat conservation plan if threatened or endangered plants are known to be present on the land to be treated.

See the appropriate section(s) of this label for specific use directions for the desired rangeland vegetation management objective.

Arsenal must only be applied to a given rangeland acre as specific weed problems arise. Long-term control of undesirable weed species ultimately depends on the successful use of land management practices that promote the growth and sustainability of desirable rangeland plant species.

Rotational Crop Instructions

Rotational crops may be planted 12 months after applying **Arsenal** at the specified pasture and rangeland rate. Following 12 months after an **Arsenal** application and before planting any crop, a successful field bioassay must be completed. The field bioassay consists of a test strip of the intended rotational crop planted in the previously treated area in the grass pasture/rangeland and grown to maturity. The test strip should include low areas and knolls and include variations in soil type and pH within the treated area. If no crop injury is evident in the test strip, the intended rotational crop may be planted the following year.

Use of **Arsenal** in accordance with label directions is expected to result in normal growth of rotational crops in most situations; however, various environmental and agronomic factors make it impossible to eliminate all risks associated with the use of this product and, therefore, rotational crop injury is always possible.

Aquatic Weed Control

Arsenal may be applied for control of floating and emergent undesirable vegetation (see **Aquatic Weeds Controlled** and **Terrestrial Weeds Controlled**) in or near bodies of water that may be flowing, nonflowing, or transient. **Arsenal** may be applied to aquatic sites that include lakes, rivers, streams, ponds, seeps, drainage ditches, canals, reservoirs, swamps, bogs, marshes, estuaries, bays, brackish water, transitional areas between terrestrial and aquatic sites, riparian sites, and seasonal wet areas. See **Product Use and Restrictions** section of this label for restrictions and instructions on aquatic uses.

Read and observe the following directions if aquatic sites are present in nonagricultural lands and are part of the intended treatment area.

Arsenal must be applied to the emergent foliage of the target vegetation and has little-to-no activity on submerged aquatic vegetation. **Arsenal** concentrations resulting from direct application to water are not expected to be of sufficient concentration or duration to control target vegetation. Apply **Arsenal** to maximize spray interception by target vegetation while minimizing the amount of overspray that enters the water.

Arsenal does not control plants that are completely submerged or have a majority of their foliage under water.

Arsenal may be applied with surface or helicopter application equipment in a minimum of 2 gallons of water per acre. When applying by helicopter, follow directions under the **Aerial Application** section of this label; otherwise, refer to the **Ground Application** section when using surface equipment.

Applications to moving bodies of water should be made while traveling upstream to prevent concentration of this herbicide in water. **DO NOT** apply to bodies of water or portions of bodies of water where emergent and/or floating weeds do not exist.

When applying to target vegetation that covers a large percentage of the surface area of impounded water, treating the area in strips may avoid oxygen depletion because of decaying vegetation. Oxygen depletion may result in the suffocation of some sensitive aquatic organisms. If oxygen depletion is a concern, treat no more than 1/2 of the surface area of the water in a single operation and wait at least 10 to 14 days between treatments. Begin treatment along the shore and proceed outward in bands to allow aquatic organisms to move into untreated areas.

Avoid washoff of sprayed foliage by spray boat or recreational boat backwash for 1 hour after application.

Apply **Arsenal** at 1 to 3 quarts per acre depending on species present and weed density. **DO NOT** exceed the maximum label rate of 3 quarts per acre (1.5 lbs ae/A) per year. Use the higher labeled rates for heavy weed pressure. Consult **Aquatic Weeds Controlled** and **Terrestrial Weeds Controlled** for specific rates.

Arsenal® herbicide may be applied as a draw-down treatment in areas described above. Apply **Arsenal** to weeds after water has been drained and allow 14 days before reintroduction of water.

Weeds Controlled

Aquatic Weeds Controlled

Arsenal® herbicide will control the following target species as specified in the **Use Rates and Application Directions** column of the table. Rates are expressed in terms of product volume for broadcast applications and as a % solution for directed applications including spot treatments. **For % solution applications, DO NOT apply more than the equivalent of 3 quarts of Arsenal per acre.**

Common Name	Scientific Name	Use Rates and Application Directions
Floating Weeds		
*Floating heart	<i>Nymphodes</i> spp.	2 to 4 pints/A (0.5 to 1.0% solution) applied in 100 GPA water mix. Ensure 100% coverage of actively growing emergent foliage.
*Frogbit	<i>Limnobium spongia</i>	1 to 2 pints/A (0.5% solution) applied in 100 GPA water mix. Ensure 100% coverage of actively growing emergent foliage.
*Spatterdock	<i>Nuphar luteum</i>	Apply a tank mix of: 2 to 4 pints/A Arsenal + 4 to 6 pints/A glyphosate (0.5% Arsenal + 1.5% glyphosate) in 100 GPA water for best control. Ensure 100% coverage of actively growing emergent foliage.
*Water hyacinth	<i>Eichhornia crassipes</i>	1 to 2 pints/A (0.5% solution) applied in 100 GPA water to actively growing foliage.
*Water lettuce	<i>Pistia stratiotes</i>	1 to 2 pints/A (0.5% solution) applied in 100 GPA water mix. Ensure 100% coverage of actively growing emergent foliage.
Emerged Weeds		
*Alligatorweed	<i>Alternanthera philoxeroides</i>	1 to 4 pints/A (0.5% solution) applied in 100 GPA water mix. Ensure 100% coverage of actively growing emergent foliage.
*Arrowhead, duck-potato	<i>Sagittaria</i> spp.	1 to 2 pints/A (0.5% solution) applied in 100 GPA water mix. Ensure 100% coverage of actively growing emergent foliage.
*Bacopa, lemon	<i>Bacopa</i> spp.	1 to 2 pints/A (0.5% solution) applied in 100 GPA water mix. Ensure 100% coverage of actively growing emergent foliage.
*Parrot feather	<i>Myriophyllum aquaticum</i>	Foliage must be above water for sufficient Arsenal uptake. Apply 2 to 4 pints/A Arsenal to actively growing emergent foliage.
*Pennywort	<i>Hydrocotyle</i> spp.	1 to 2 pints/A (0.5% solution) applied in 100 GPA water mix. Ensure 100% coverage of actively growing emergent foliage.
*Pickerelweed	<i>Pontederia cordata</i>	2 to 3 pints/A (1% solution) applied in 100 GPA water mix. Ensure 100% coverage of actively growing emergent foliage.
*Taro, wild Coco yam Dasheen Elephant's ear	<i>Colocasia esculentum</i>	4 to 6 pints/A (1.5% solution) applied in 100 GPA with a high quality sticker adjuvant. Ensure good coverage of actively growing emergent foliage.

* Use not permitted in California unless otherwise directed by supplemental labeling.

(continued)

Aquatic Weeds Controlled *(continued)*

Common Name	Scientific Name	Use Rates and Application Directions
Emergent Weeds <i>(continued)</i>		
*Water chestnut	<i>Trappa natans</i>	4 to 6 pints/A (1.5% solution) applied in 100 GPA with a high quality sticker adjuvant. Ensure good coverage of actively growing emergent foliage.
*Water lily	<i>Nymphaea odorata</i>	2 to 3 pints/A (1% solution) applied in 100 GPA water mix. Ensure 100% coverage of actively growing emergent foliage.
*Water primrose	<i>Ludwigia uruguayensis</i>	4 to 6 pints/A (1.5% solution). Ensure 100% coverage of actively growing emergent foliage.
Terrestrial/Marginal Weeds		
*Aquatic nightshade Soda apple	<i>Solanum tampicense</i>	2 pints/A applied to foliage
*Bamboo, Japanese	<i>Phyllostachys</i> spp.	3 to 4 pints/A applied to foliage when plant is actively growing; before setting seedhead. More foliage will result in greater herbicide uptake, resulting in greater root kill.
Beach, vitex	<i>Vitex rotundifolia</i>	5% solution + 1% MSO foliar spray 17% solution stem injection (hack and squirt)
Brazilian pepper Christmasberry	<i>Schinus terebinthifolius</i>	2 to 4 pints/A applied to foliage
Cattail	<i>Typha</i> spp.	2 to 4 pints/A (1% solution) applied to actively growing green foliage after full leaf elongation. Lower rates will control cattail in the North; higher rates are needed in the South.
Chinese tallow tree	<i>Sapium sebiferum</i>	16 to 24 fl ozs/A applied to foliage
Cogongrass	<i>Imperata cylindrica</i>	Burn foliage, till area; then fall-spray 2 quarts/A Arsenal® herbicide + MSO applied to new growth.
Cordgrass, prairie	<i>Spartina</i> spp.	4 to 6 pints/A applied to actively growing foliage
*Cutgrass	<i>Zizaniopsis miliacea</i>	4 to 6 pints/A applied to actively growing foliage
*Elephant grass Napier grass	<i>Pennisetum purpureum</i>	3 pints/A applied to actively growing foliage
*Flowering rush	<i>Butomus umbellatus</i> L.	2 to 3 pints/A applied to actively growing foliage
Giant reed Wild cane	<i>Arundo donax</i>	4 to 6 pints/A applied in spring to actively growing foliage
*Golden bamboo	<i>Phyllostachys aurea</i>	3 to 4 pints/A applied to foliage when plant is actively growing; before setting seedhead. More foliage will result in greater herbicide uptake, resulting in greater root kill.
Junglerice	<i>Echinochloa colonum</i>	3 to 4 pints/A applied to actively growing foliage
Knapweed	<i>Centaurea</i> spp.	Russian knapweed: 2 to 3 pints/A + 1 quart/A MSO fall-applied after senescence begins
Knotweed, Japanese	<i>Polygonum cuspidatum</i> <i>Fallopia japonica</i>	3 to 4 pints/A applied postemergence to actively growing foliage

* Use not permitted in California unless otherwise directed by supplemental labeling.

(continued)

Aquatic Weeds Controlled *(continued)*

Common Name	Scientific Name	Use Rates and Application Directions
Terrestrial/Marginal Weeds <i>(continued)</i>		
Melaleuca Paperbark tree	<i>Melaleuca quinquenervia</i>	<ul style="list-style-type: none"> • Established stands - Apply 6 pints/A Arsenal[®] herbicide + 6 pints/A glyphosate + spray adjuvant. For best results, use 4 quarts/A MSO as an adjuvant. • Ground foliar application - Uniformly apply to ensure 100% coverage. • Broadcast foliar control - Apply aerially in a minimum of 2 passes at 10 gallons/A applied cross treatment. • Spot treatment - Use a 25% Arsenal + 25% solution of glyphosate + 1.25% MSO in water applied as a frill or stump treatment.
*Nutmeg Kili'p'opu	<i>Cyperus rotundus</i>	2 pints/A Arsenal + 1 quart/A MSO applied early postemergence
*Nutsedge	<i>Cyperus</i> spp.	2 to 3 pints/A postemergence to foliage or preemergence incorporated; nonincorporated preemergence applications will not control.
Phragmites Common reed	<i>Phragmites australis</i>	4 to 6 pints/A applied to actively growing green foliage after full leaf elongation. Ensure 100% coverage. If stand has a substantial amount of old stem tissue, mow or burn; allow to regrow to approximately 5 feet tall before treatment. Lower rates will control phragmites in the North; higher rates are needed in the South.
*Poison hemlock	<i>Conium maculatum</i>	2 pints/A Arsenal + 1 quart/A MSO applied preemergence to early postemergence to rosette before flowering
Purple loosestrife	<i>Lythrum salicaria</i>	1 pint/A applied to actively growing foliage
Reed canarygrass	<i>Phalaris arundinacea</i>	3 to 4 pints/A applied to actively growing foliage
Rose, swamp	<i>Rosa palustris</i>	2 to 3 pints/A applied to actively growing foliage
Russian olive	<i>Elaeagnus angustifolia</i>	2 to 4 pints/A (1% solution) applied to foliage
Saltcedar Tamarisk	<i>Tamarix</i> spp.	Aerial application - 2 quarts Arsenal + 0.25% v/v NIS applied to actively growing foliage during flowering. Spot treatment - Use 1% solution of Arsenal + 0.25% v/v NIS and spray to wet foliage. After application, wait at least 2 years before disturbing treated saltcedar. Earlier disturbance can reduce overall control.
Smartweed	<i>Polygonum</i> spp.	2 pints/A applied early postemergence
Sumac	<i>Rhus</i> spp.	2 to 3 pints/A applied to foliage
Swamp morningglory Kangkong Water spinach	<i>Ipomoea aquatica</i>	1 to 2 pints/A Arsenal + 1 quart/A MSO applied early postemergence
Torpedo grass	<i>Panicum repens</i>	4 pints/A (1.0 to 1.5% solution). Ensure good coverage to actively growing foliage.
*White top Hoary cress	<i>Cardaria draba</i>	1 to 2 pints/A applied in spring to foliage during flowering
Willow	<i>Salix</i> spp.	2 to 3 pints/A Arsenal applied to actively growing foliage. Ensure good coverage.

* Use not permitted in California unless otherwise directed by supplemental labeling.

Terrestrial Weed Control

In terrestrial sites, **Arsenal**[®] herbicide will provide pre-emergence or postemergence control with residual control of the following target vegetation species at the rates listed. Residual control refers to control of newly germinating seedlings in both annuals and perennials. In general, annual weeds may be controlled by preemergence or postemergence applications of **Arsenal**. For established biennials and perennials, postemergence applications of **Arsenal** will provide the best control.

The rates shown below refer to broadcast applications and indicate the relative sensitivity of these weeds. The relative sensitivity should be referenced when preparing low-volume spray solutions (see **Low-volume Foliar Application** section of **Ground Application**); low-volume applications may provide control of the target species with less **Arsenal** per acre than is shown for the broadcast treatments. Use **Arsenal** only in accordance with the specific use directions on this label and the leaflet label.

Use the relative sensitivity of the species listed following to determine the relative risk of nontarget plant injury if any of the species listed following are considered to be desirable within the area to be treated.

Resistant Biotypes. Naturally occurring biotypes (a plant within a given species that has a slightly different but distinct genetic makeup from other plants of the same species) of some weeds listed on this label may not be effectively controlled. If naturally occurring resistant biotypes are present in an area, tank mix **Arsenal** or apply sequentially with an appropriate registered herbicide having a different mode of action to ensure control.

Terrestrial Weeds Controlled

Common Name	Scientific Name	Growth Habit ²
Grass Weeds		
Apply 2 to 3 pts/A¹		
Annual bluegrass	<i>Poa annua</i>	A
Broadleaf signalgrass	<i>Brachiaria platyphylla</i>	A
Canada bluegrass	<i>Poa compressa</i>	P
Downy brome	<i>Bromus tectorum</i>	A
Fescue	<i>Festuca</i> spp.	A/P
Foxtail	<i>Setaria</i> spp.	A
Italian ryegrass	<i>Lolium multiflorum</i>	A
Johnsongrass ⁴	<i>Sorghum halepense</i>	P
Kentucky bluegrass	<i>Poa pratensis</i>	P
Napier grass ⁵	<i>Pennisetum purpureum</i>	P
Orchardgrass	<i>Dactylis glomerata</i>	P
Paragrass	<i>Brachiaria mutica</i>	P
Quackgrass	<i>Agropyron repens</i>	P

(continued)

Terrestrial Weeds Controlled (continued)

Common Name	Scientific Name	Growth Habit ²
Grass Weeds (continued)		
Apply 2 to 3 pts/A¹ (continued)		
Sandbur	<i>Cenchrus</i> spp.	A
Smooth brome	<i>Bromus inermis</i>	P
Vaseygrass	<i>Paspalum urvillei</i>	P
Wild oats	<i>Avena fatua</i>	A
Witchgrass	<i>Panicum capillare</i>	A
Apply 3 to 4 pts/A¹		
Barnyardgrass	<i>Echinochloa crus-galli</i>	A
Beardgrass	<i>Andropogon</i> spp.	P
Bluegrass, annual	<i>Poa annua</i>	A
Bulrush ⁵	<i>Scirpus validus</i>	P
Cheat	<i>Bromus secalinus</i>	A
Cogongrass	<i>Imperata cylindrica</i>	P
Crabgrass	<i>Digitaria</i> spp.	A
Crowfootgrass	<i>Dactyloctenium aegyptium</i>	A
Fall panicum	<i>Panicum dichotomiflorum</i>	A
Goosegrass	<i>Eleusine indica</i>	A
Itchgrass	<i>Rottboellia exaltata</i>	A
Lovegrass ⁴	<i>Eragrostis</i> spp.	P
Maidencane ⁵	<i>Panicum hemitomon</i>	A
Panicum, browntop	<i>Panicum fasciculatum</i>	A
Panicum, Texas	<i>Panicum texanum</i>	A
Prairie threeawn	<i>Aristida oligantha</i>	P
Sandbur, field	<i>Cenchrus incertus</i>	A
Signalgrass	<i>Brachiaria platyphylla</i>	A
Wild barley	<i>Hordeum</i> spp.	A
Woolly cupgrass	<i>Eriochloa villosa</i>	A

Apply 4 to 6 pts/A¹

Bahiagrass	<i>Paspalum notatum</i>	P
Bermudagrass ^{3,4}	<i>Cynodon dactylon</i>	P
Big bluestem	<i>Andropogon gerardii</i>	P
Dallisgrass	<i>Paspalum dilatatum</i>	P
Feathertop	<i>Pennisetum villosum</i>	P
Guineagrass	<i>Panicum maximum</i>	P
Saltgrass ³	<i>Distichlis stricta</i>	P
Sand dropseed	<i>Sporobolus cryptandrus</i>	P
Sprangletop	<i>Leptochloa</i> spp.	A
Timothy	<i>Phleum pratense</i>	P
Wirestem muhly	<i>Muhlenbergia frondosa</i>	P

¹ Use higher rate where heavy or well-established infestations occur.

² Growth Habit: A = Annual, B = Biennial, P = Perennial

³ Use a minimum of 75 GPA.

⁴ Use higher labeled rates.

⁵ Use not permitted in California unless otherwise directed by supplemental labeling.

Terrestrial Weeds Controlled *(continued)*

Common Name	Scientific Name	Growth Habit ²
Broadleaf Weeds		
Apply 2 to 3 pts/A¹		
Burdock	<i>Arctium</i> spp.	B
Carolina geranium	<i>Geranium carolinianum</i>	A
Carpetweed	<i>Mollugo verticillata</i>	A
Clover	<i>Trifolium</i> spp.	A/P
Common chickweed	<i>Stellaria media</i>	A
Common ragweed	<i>Ambrosia artemisiifolia</i>	A
Dandelion	<i>Taraxacum officinale</i>	P
Dogfennel	<i>Eupatorium capillifolium</i>	A
Filaree	<i>Erodium</i> spp.	A
Fleabane	<i>Erigeron</i> spp.	A
Hoary vervain	<i>Verbena stricta</i>	P
Indian mustard	<i>Brassica juncea</i>	A
Kochia	<i>Kochia scoparia</i>	A
Lambsquarters	<i>Chenopodium album</i>	A
Lespedeza ³	<i>Lespedeza</i> spp.	P
Miner's lettuce	<i>Montia perfoliata</i>	A
Mullein	<i>Verbascum</i> spp.	B
Nettleleaf goosefoot	<i>Chenopodium murale</i>	A
Oxeye daisy	<i>Chrysanthemum leucanthemum</i>	P
Pepperweed	<i>Lepidium</i> spp.	A
Pigweed	<i>Amaranthus</i> spp.	A
Puncturevine	<i>Tribulus terrestris</i>	A
Russian thistle	<i>Salsola kali</i>	A
Smartweed	<i>Polygonum</i> spp.	A/P
Sorrell	<i>Rumex</i> spp.	P
Sunflower	<i>Helianthus</i> spp.	A
Sweet clover	<i>Melilotus</i> spp.	A/B
Tansymustard	<i>Descurainia pinnata</i>	A
Western ragweed	<i>Ambrosia psilostachya</i>	P
Wild carrot	<i>Daucus carota</i>	B
Wild lettuce	<i>Lactuca</i> spp.	A/B
Wild parsnip	<i>Pastinaca sativa</i>	B
Wild turnip	<i>Brassica campestris</i>	B
Woollyleaf bursage	<i>Franseria tomentosa</i>	P
Yellow woodsorrel	<i>Oxalis stricta</i>	P

(continued)

Terrestrial Weeds Controlled *(continued)*

Common Name	Scientific Name	Growth Habit ²
Broadleaf Weeds <i>(continued)</i>		
Apply 3 to 4 pts/A¹		
Broom snakeweed ⁴	<i>Gutierrezia sarothrae</i>	P
Bull thistle	<i>Cirsium vulgare</i>	B
Burclover	<i>Medicago</i> spp.	A
Chickweed, mouseear	<i>Cerastium vulgatum</i>	A
Clover, hop	<i>Trifolium procumbens</i>	A
Cocklebur	<i>Xanthium strumarium</i>	A
Cudweed	<i>Gnaphalium</i> spp.	A
Desert camelthorn	<i>Alhagi pseudalhagi</i>	P
Dock	<i>Rumex</i> spp.	P
Fiddleneck	<i>Amsinckia intermedia</i>	A
Goldenrod	<i>Solidago</i> spp.	P
Henbit	<i>Lamium amplexicaule</i>	A
Knotweed, prostrate	<i>Polygonum aviculare</i>	A/P
Pokeweed	<i>Phytolacca americana</i>	P
Purslane	<i>Portulaca</i> spp.	A
Pusley, Florida	<i>Richardia scabra</i>	A
Rocket, London	<i>Sisymbrium irio</i>	A
Rush skeletonweed ⁴	<i>Chondrilla juncea</i>	B
Saltbush	<i>Atriplex</i> spp.	A
Shepherdspurse	<i>Capsella bursa-pastoris</i>	A
Spurge, annual	<i>Euphorbia</i> spp.	A
Stinging nettle ⁴	<i>Urtica dioica</i>	P
Velvetleaf	<i>Abutilon theophrasti</i>	A
Yellow starthistle	<i>Centaurea solstitialis</i>	A
Apply 4 to 6 pts/A¹		
Arrowwood	<i>Pluchea sericea</i>	A
Canada thistle	<i>Cirsium arvense</i>	P
Giant ragweed	<i>Ambrosia trifida</i>	A
Gray rabbitbrush	<i>Chrysothamnus nauseosus</i>	P
Little mallow	<i>Malva parviflora</i>	B
Milkweed	<i>Asclepias</i> spp.	P
Primrose	<i>Oenothera kunthiana</i>	P
Silverleaf nightshade	<i>Solanum elaeagnifolium</i>	P
Sowthistle	<i>Sonchus</i> spp.	A
Texas thistle	<i>Cirsium texanum</i>	P

¹ Use higher rate where heavy or well-established infestations occur.

² Growth Habit: A = Annual, B = Biennial, P = Perennial

³ Use not permitted in California unless otherwise directed by supplemental labeling.

⁴ For best results, early postemergence applications are required.

Terrestrial Weeds Controlled (continued)

Common Name	Scientific Name	Growth Habit ²
Vines and Brambles		
Apply 1 pt/A		
Field bindweed	<i>Convolvulus arvensis</i>	P
Hedge bindweed	<i>Calystegia sepium</i>	A
Apply 2 to 3 pts/A¹		
Wild buckwheat	<i>Polygonum convolvulus</i>	P
Apply 3 to 4 pts/A¹		
Greenbriar	<i>Smilax</i> spp.	P
Honeysuckle ³	<i>Lonicera</i> spp.	P
Morningglory	<i>Ipomoea</i> spp.	A/P
Poison ivy	<i>Rhus radicans</i>	P
Redvine	<i>Brunnichia cirrhosa</i>	P
Wild rose ³	<i>Rosa</i> spp.	P
including:		
Multiflora rose	<i>Rosa multiflora</i>	P
Macartney rose	<i>Rosa bracteata</i>	P
Apply 4 to 6 pts/A¹		
Trumpet creeper	<i>Campsis radicans</i>	P
Virginia creeper	<i>Parthenocissus quinquefolia</i>	P
Wild grape	<i>Vitis</i> spp.	P

¹ Use higher rate where heavy or well-established infestations occur.

² Growth Habit: A = Annual, B = Biennial, P = Perennial

³ Use higher labeled rates.

Common Name	Scientific Name	Growth Habit ²
Brush Species		
Apply 2 to 4 pts/A¹		
Brazilian peppertree	<i>Schinus terebinthifolius</i>	P
Chinese tallow tree	<i>Sapium sebiferum</i>	P
Popcorn tree		
Russian olive	<i>Elaeagnus angustifolia</i>	P
Sumac	<i>Rhus</i> spp.	P
Willow	<i>Salix</i> spp.	P
Apply 4 to 6 pts/A¹		
Alder	<i>Alnus</i> spp.	P
American beech	<i>Fagus grandifolia</i>	P
Ash ³	<i>Fraxinus</i> spp.	P
Aspen	<i>Populus</i> spp.	P
Autumn olive	<i>Elaeagnus umbellata</i>	P
Bald cypress	<i>Taxodium distichum</i>	P
Bigleaf maple	<i>Acer macrophyllum</i>	P
Birch ³	<i>Betula</i> spp.	P
Black gum ⁴	<i>Nyssa sylvatica</i>	P
Black oak	<i>Quercus kelloggii</i>	P
Boxelder	<i>Acer negundo</i>	P
Ceanothis	<i>Ceanothis</i> spp.	P
Cherry ^{3,4}	<i>Prunus</i> spp.	P

(continued)

Terrestrial Weeds Controlled (continued)

Common Name	Scientific Name	Growth Habit ²
Brush Species (continued)		
Apply 4 to 6 pts/A¹		
Chinaberry	<i>Melia azedarach</i>	P
Chinquapin	<i>Castanopsis chrysophylla</i>	P
Cottonwood	<i>Populus trichocarpa</i>	
	<i>P. deltoides</i>	P
Cypress	<i>Taxodium</i> spp.	P
Dogwood ³	<i>Cornus</i> spp.	P
Elm ⁵	<i>Ulmus</i> spp.	P
Eucalyptus	<i>Eucalyptus</i> spp.	P
Hawthorn	<i>Crataegus</i> spp.	P
Hickory ³	<i>Carya</i> spp.	P
Huckleberry	<i>Gaylussacia</i> spp.	P
Lyonia spp.		
including:		
Fetterbush	<i>Lyonia lucida</i>	
Staggerbush	<i>Lyonia mariana</i>	P
Madrone	<i>Arbutus menziesii</i>	P
Maple	<i>Acer</i> spp.	P
Melaleuca	<i>Melaleuca quinquenervia</i>	P
Mulberry ^{3,6}	<i>Morus</i> spp.	P
Oak ⁷	<i>Quercus</i> spp.	P
Persimmon ⁴	<i>Diospyros virginiana</i>	P
Poison oak	<i>Rhus diversiloba</i>	P
Poplar	<i>Populus</i> spp.	P
Privet	<i>Ligustrum vulgare</i>	P
Red alder	<i>Alnus rubra</i>	P
Red maple	<i>Acer rubrum</i>	P
Saltcedar	<i>Tamarix pentandra</i>	P
Sassafras	<i>Sassafras albidum</i>	P
Sourwood ⁴	<i>Oxydendrum arboreum</i>	P
Sweetgum	<i>Liquidambar styraciflua</i>	P
Sycamore	<i>Platanus occidentalis</i>	P
Tanoak ³	<i>Lithocarpus densiflorus</i>	P
Titi ⁸	<i>Cyrilla racemiflora</i>	P
Tree of heaven	<i>Ailanthus altissima</i>	P
Vaccinium spp.		
including:		
Blueberry	<i>Vaccinium</i> spp.	
Sparkleberry	<i>Vaccinium arboreum</i>	P
Water willow ⁹	<i>Justicia americana</i>	P
Yellow poplar ³	<i>Liriodendron tulipifera</i>	P

¹ Use higher rate where heavy or well-established infestations occur.

² Growth Habit: A = Annual, B = Biennial, P = Perennial

³ Use higher labeled rates.

⁴ Best control with applications before formation of fall leaf color

⁵ Tank mix with glyphosate

⁶ Degree of control may be species dependent.

⁷ For water oak (*Quercus nigra*), laurel oak (*Q. lauriflora*), willow oak (*Q. phellos*), and live oak (*Q. virginiana*), use higher labeled rates.

⁸ Suppression only

⁹ **Use not permitted in California unless otherwise directed by supplemental labeling.**

Conditions of Sale and Warranty

The **Directions For Use** of this product reflect the opinion of experts based on field use and tests. The directions are believed to be reliable and must be followed carefully. However, it is impossible to eliminate all risks inherently associated with the use of this product. Crop injury, ineffectiveness or other unintended consequences may result because of such factors as weather conditions, presence of other materials, or use of the product in a manner inconsistent with its labeling, all of which are beyond the control of BASF CORPORATION ("BASF") or the Seller. To the extent consistent with applicable law, all such risks shall be assumed by the Buyer.

BASF warrants that this product conforms to the chemical description on the label and is reasonably fit for the purposes referred to in the **Directions For Use**, subject to the inherent risks, referred to above.

TO THE EXTENT CONSISTENT WITH APPLICABLE LAW, BASF MAKES NO OTHER EXPRESS OR IMPLIED WARRANTY OF FITNESS OR MERCHANTABILITY OR ANY OTHER EXPRESS OR IMPLIED WARRANTY.

TO THE EXTENT CONSISTENT WITH APPLICABLE LAW, BUYER'S EXCLUSIVE REMEDY AND BASF'S EXCLUSIVE LIABILITY, WHETHER IN CONTRACT, TORT, NEGLIGENCE, STRICT LIABILITY, OR OTHERWISE, SHALL BE LIMITED TO REPAYMENT OF THE PURCHASE PRICE OF THE PRODUCT.

TO THE EXTENT CONSISTENT WITH APPLICABLE LAW, BASF AND THE SELLER DISCLAIM ANY LIABILITY FOR CONSEQUENTIAL, EXEMPLARY, SPECIAL OR INDIRECT DAMAGES RESULTING FROM THE USE OR HANDLING OF THIS PRODUCT.

BASF and the Seller offer this product, and the Buyer and User accept it, subject to the foregoing **Conditions of Sale and Warranty** which may be varied only by agreement in writing signed by a duly authorized representative of BASF.

1108

Arsenal, Overdrive, and Pendulum are registered trademarks of BASF.

AquaCap is a trademark of BASF.

Accord and Garlon are registered trademarks of Dow AgroSciences LLC.

Roundup is a registered trademark of Monsanto Technology LLC.

Embark is a registered trademark of PBI-Gordon Corporation.

Escort and Krenite are registered trademarks of E.I. duPont de Nemours and Company.

Microfoil is a trademark of Rhone Poulenc Ag Company.

Thru-Valve is a trademark of Waldrum Specialties.

© 2012 BASF Corporation
All rights reserved.

000241-00346.20120911b.NVA 2012-04-104-0184

Based on: NVA 2011-04-104-0062

Supersedes: NVA 2011-04-104-0115

BASF Corporation
26 Davis Drive
Research Triangle Park, NC 27709

 **BASF**

The Chemical Company

Safety Data Sheet

Arsenal Herbicide

Revision date : 2021/11/03
Version: 5.0

Page: 1/13
(30256051/SDS_CPA_US/EN)

1. Identification

Product identifier used on the label

Arsenal Herbicide

Recommended use of the chemical and restriction on use

Recommended use*: crop protection product, herbicide

* The "Recommended use" identified for this product is provided solely to comply with a Federal requirement and is not part of the seller's published specification. The terms of this Safety Data Sheet (SDS) do not create or infer any warranty, express or implied, including by incorporation into or reference in the seller's sales agreement.

Details of the supplier of the safety data sheet

Company:
BASF CORPORATION
100 Park Avenue
Florham Park, NJ 07932, USA

Telephone: +1 973 245-6000

Emergency telephone number

24 Hour Emergency Response Information

CHEMTREC: 1-800-424-9300
BASF HOTLINE: 1-800-832-HELP (4357)

Other means of identification

Substance number: 63383
EPA Registration number: 241-346
Molecular formula: C(13) H(15) N(3) O(3). C(3) H(9) N
Chemical family: imidazole derivative
Synonyms: Isopropylamine salt of imazapyr

2. Hazards Identification

According to Regulation 2012 OSHA Hazard Communication Standard; 29 CFR Part 1910.1200

Classification of the product

Skin Corr./Irrit.	1A	Skin corrosion/irritation
Eye Dam./Irrit.	1	Serious eye damage/eye irritation
Aquatic Acute	2	Hazardous to the aquatic environment - acute

Safety Data Sheet

Arsenal Herbicide

Revision date : 2021/11/03
Version: 5.0

Page: 2/13
(30256051/SDS_CPA_US/EN)

Aquatic Chronic

2

Hazardous to the aquatic environment - chronic

Label elements

Pictogram:



Signal Word:
Danger

Hazard Statement:

H314 Causes severe skin burns and eye damage.
H401 Toxic to aquatic life.
H411 Toxic to aquatic life with long lasting effects.

Precautionary Statements (Prevention):

P280 Wear protective gloves, protective clothing and eye protection or face protection.
P273 Avoid release to the environment.
P260 Do not breathe mist or vapour.
P264 Wash contaminated body parts thoroughly after handling.

Precautionary Statements (Response):

P305 + P351 + P338 IF IN EYES: Rinse cautiously with water for several minutes. Remove contact lenses, if present and easy to do. Continue rinsing.
P310 Immediately call a POISON CENTER or physician.
P303 + P361 + P353 IF ON SKIN (or hair): Remove or Take off immediately all contaminated clothing. Rinse skin with water or shower.
P304 + P340 IF INHALED: Remove person to fresh air and keep comfortable for breathing.
P301 + P330 + P331 IF SWALLOWED: rinse mouth. Do NOT induce vomiting.
P363 Wash contaminated clothing before reuse.
P391 Collect spillage.

Precautionary Statements (Storage):

P405 Store locked up.

Precautionary Statements (Disposal):

P501 Dispose of contents/container in accordance with local regulations.

3. Composition / Information on Ingredients

According to Regulation 2012 OSHA Hazard Communication Standard; 29 CFR Part 1910.1200

Imazapyr technical

CAS Number: 81334-34-1
Content (W/W): 22.65 %
Synonym: No data available.

isopropylamine

CAS Number: 75-31-0
Content (W/W): 5.0 - 10.0%
Synonym: Isopropylamine

Safety Data Sheet

Arsenal Herbicide

Revision date : 2021/11/03
Version: 5.0

Page: 3/13
(30256051/SDS_CPA_US/EN)

4. First-Aid Measures

Description of first aid measures

General advice:

First aid personnel should pay attention to their own safety. If the patient is likely to become unconscious, place and transport in stable sideways position (recovery position). Immediately remove contaminated clothing.

If inhaled:

Keep patient calm, remove to fresh air, seek medical attention. Immediately administer a corticosteroid from a controlled/metered dose inhaler.

If on skin:

Immediately wash thoroughly with plenty of water, apply sterile dressings, consult a skin specialist.

If in eyes:

Immediately wash affected eyes for at least 15 minutes under running water with eyelids held open, consult an eye specialist.

If swallowed:

Do not induce vomiting. Immediately rinse mouth and then drink 200-300 ml of water, seek medical attention.

Most important symptoms and effects, both acute and delayed

Symptoms: (Further) symptoms and / or effects are not known so far

Indication of any immediate medical attention and special treatment needed

Note to physician

Treatment: Treat according to symptoms (decontamination, vital functions), no known specific antidote.

5. Fire-Fighting Measures

Extinguishing media

Suitable extinguishing media:
water spray, carbon dioxide, foam, dry powder

Special hazards arising from the substance or mixture

Hazards during fire-fighting:
carbon monoxide, carbon dioxide, nitrogen oxides
The substances/groups of substances mentioned can be released in case of fire.

Advice for fire-fighters

Protective equipment for fire-fighting:
Firefighters should be equipped with self-contained breathing apparatus and turn-out gear.

Further information:

In case of fire and/or explosion do not breathe fumes. Keep containers cool by spraying with water if exposed to fire. Collect contaminated extinguishing water separately, do not allow to reach sewage

Safety Data Sheet

Arsenal Herbicide

Revision date : 2021/11/03
Version: 5.0

Page: 4/13
(30256051/SDS_CPA_US/EN)

or effluent systems. Dispose of fire debris and contaminated extinguishing water in accordance with official regulations.

6. Accidental release measures

Personal precautions, protective equipment and emergency procedures

Take appropriate protective measures. Clear area. Shut off source of leak only under safe conditions. Extinguish sources of ignition nearby and downwind. Ensure adequate ventilation. Wear suitable personal protective clothing and equipment.

Environmental precautions

Do not discharge into the subsoil/soil. Do not discharge into drains/surface waters/groundwater. Contain contaminated water/firefighting water.

Methods and material for containment and cleaning up

Dike spillage. Pick up with suitable absorbent material. Place into suitable containers for reuse or disposal in a licensed facility. Spilled substance/product should be recovered and applied according to label rates whenever possible. If application of spilled substance/product is not possible, then spills should be contained, solidified, and placed in suitable containers for disposal. After decontamination, spill area can be washed with water. Collect wash water for approved disposal.

7. Handling and Storage

Precautions for safe handling

RECOMMENDATIONS ARE FOR MANUFACTURING, COMMERCIAL BLENDING, AND PACKAGING WORKERS. PESTICIDE APPLICATORS & WORKERS must refer to the Product Label and Directions for Use attached to the product for Agricultural Use Requirements in accordance with the EPA Worker Protection Standard 40 CFR part 170. Ensure adequate ventilation. Provide good ventilation of working area (local exhaust ventilation if necessary). Keep away from sources of ignition - No smoking. Keep container tightly sealed. Protect contents from the effects of light. Protect against heat. Protect from air. Handle and open container with care. Do not open until ready to use. Once container is opened, content should be used as soon as possible. Avoid aerosol formation. Avoid dust formation. Provide means for controlling leaks and spills. Do not return residues to the storage containers. Follow label warnings even after container is emptied. The substance/ product may be handled only by appropriately trained personnel. Avoid all direct contact with the substance/product. Avoid contact with the skin, eyes and clothing. Avoid inhalation of dusts/mists/vapours. Wear suitable personal protective clothing and equipment.

Protection against fire and explosion:

The relevant fire protection measures should be noted. Fire extinguishers should be kept handy. Avoid all sources of ignition: heat, sparks, open flame. Sources of ignition should be kept well clear. Avoid extreme heat. Keep away from oxidizable substances. Electrical equipment should conform to national electric code. Ground all transfer equipment properly to prevent electrostatic discharge. Electrostatic discharge may cause ignition.

Conditions for safe storage, including any incompatibilities

Segregate from incompatible substances. Segregate from foods and animal feeds. Segregate from textiles and similar materials.

Further information on storage conditions: Keep only in the original container in a cool, dry, well-ventilated place away from ignition sources, heat or flame. Protect containers from physical damage. Protect against contamination. The authority permits and storage regulations must be observed. Protect from temperatures below: 0 °C

Safety Data Sheet

Arsenal Herbicide

Revision date : 2021/11/03

Version: 5.0

Page: 5/13

(30256051/SDS_CPA_US/EN)

Changes in the properties of the product may occur if substance/product is stored below indicated temperature for extended periods of time.

Protect from temperatures above: 40 °C

Changes in the properties of the product may occur if substance/product is stored above indicated temperature for extended periods of time.

8. Exposure Controls/Personal Protection

Users of a pesticidal product should refer to the product label for personal protective equipment requirements.

Components with occupational exposure limits

isopropylamine	OSHA Z1:	PEL 5 ppm 12 mg/m ³ ;
	ACGIH, US:	TWA value 2 ppm ;
	ACGIH, US:	STEL value 5 ppm ;
	ACGIH, US:	Skin Designation ; Danger of cutaneous absorption

Advice on system design:

Whenever possible, engineering controls should be used to minimize the need for personal protective equipment.

Personal protective equipment

RECOMMENDATIONS FOR MANUFACTURING, COMMERCIAL BLENDING, AND PACKAGING WORKERS:

Respiratory protection:

Wear respiratory protection if ventilation is inadequate. Wear a NIOSH-certified (or equivalent) TC23C Chemical/Mechanical type filter system to remove a combination of particles, gas and vapours. For situations where the airborne concentrations may exceed the level for which an air purifying respirator is effective, or where the levels are unknown or Immediately Dangerous to Life or Health (IDLH), use NIOSH-certified full facepiece pressure demand self-contained breathing apparatus (SCBA) or a full facepiece pressure demand supplied-air respirator (SAR) with escape provisions.

Hand protection:

Chemical resistant protective gloves, Protective glove selection must be based on the user's assessment of the workplace hazards.

Eye protection:

Safety glasses with side-shields. Tightly fitting safety goggles (chemical goggles). Wear face shield if splashing hazard exists.

Body protection:

Body protection must be chosen depending on activity and possible exposure, e.g. head protection, apron, protective boots, chemical-protection suit.

General safety and hygiene measures:

Wear long sleeved work shirt and long work pants in addition to other stated personal protective equipment. Work place should be equipped with a shower and an eye wash. Handle in accordance with good industrial hygiene and safety practice. Personal protective equipment should be decontaminated prior to reuse. Gloves must be inspected regularly and prior to each use. Replace if necessary (e.g. pinhole leaks). Take off immediately all contaminated clothing. Store work clothing separately. Hands and/or face should be washed before breaks and at the end of the shift. No

Safety Data Sheet

Arsenal Herbicide

Revision date : 2021/11/03

Version: 5.0

Page: 6/13

(30256051/SDS_CPA_US/EN)

eating, drinking, smoking or tobacco use at the place of work. Keep away from food, drink and animal feeding stuffs.

9. Physical and Chemical Properties

Form:	liquid
Odour:	ammonia-like, faint odour
Odour threshold:	not applicable, odour not perceivable
Colour:	blue, clear
pH value:	6.6 - 7.2
Freezing point:	approx. 0 °C (1,013.3 hPa)
Boiling point:	Information applies to the solvent. approx. 100 °C (1,013.3 hPa)
Flash point:	Information applies to the solvent. A flash point determination is unnecessary due to the high water content.
Flammability:	not applicable
Lower explosion limit:	As a result of our experience with this product and our knowledge of its composition we do not expect any hazard as long as the product is used appropriately and in accordance with the intended use.
Upper explosion limit:	As a result of our experience with this product and our knowledge of its composition we do not expect any hazard as long as the product is used appropriately and in accordance with the intended use.
Autoignition:	Based on the water content the product does not ignite.
Vapour pressure:	approx. 23.3 hPa (20 °C) Information applies to the solvent. < 100 hPa (50 °C) Information applies to the solvent.
Density:	1.04 - 1.09 g/ml
Vapour density:	not applicable
Partitioning coefficient n-octanol/water (log Pow):	not applicable
Thermal decomposition:	carbon monoxide, carbon dioxide, nitrogen oxide Stable at ambient temperature. If product is heated above decomposition temperature toxic vapours may be released. If product is heated above decomposition temperature hazardous fumes may be released.
Viscosity, dynamic:	approx. 26.3 mPa.s (20 °C)
Solubility in water:	miscible
Molar mass:	320.4 g/mol
Evaporation rate:	not applicable
Other Information:	If necessary, information on other physical and chemical parameters is indicated in this section.

Safety Data Sheet

Arsenal Herbicide

Revision date : 2021/11/03
Version: 5.0

Page: 7/13
(30256051/SDS_CPA_US/EN)

10. Stability and Reactivity

Reactivity

No hazardous reactions if stored and handled as prescribed/indicated.

Corrosion to metals:
Corrosive effect on: mild steel brass

Oxidizing properties:
Not an oxidizer.

Chemical stability

The product is stable if stored and handled as prescribed/indicated.

Possibility of hazardous reactions

The product is chemically stable.

Conditions to avoid

Avoid all sources of ignition: heat, sparks, open flame. Avoid prolonged storage. Avoid electro-static discharge. Avoid contamination. Avoid prolonged exposure to extreme heat. Avoid extreme temperatures.

Incompatible materials

oxidizing agents, reducing agents

Hazardous decomposition products

Decomposition products:
Hazardous decomposition products: No hazardous decomposition products if stored and handled as prescribed/indicated., Prolonged thermal loading can result in products of degradation being given off.

Thermal decomposition:
Possible thermal decomposition products:
carbon monoxide, carbon dioxide, nitrogen oxide
Stable at ambient temperature. If product is heated above decomposition temperature toxic vapours may be released. If product is heated above decomposition temperature hazardous fumes may be released.

11. Toxicological information

Primary routes of exposure

Routes of entry for solids and liquids are ingestion and inhalation, but may include eye or skin contact. Routes of entry for gases include inhalation and eye contact. Skin contact may be a route of entry for liquefied gases.

Acute Toxicity/Effects

Acute toxicity

Assessment of acute toxicity: Relatively nontoxic after single ingestion. Slightly toxic after short-term skin contact. Relatively nontoxic after short-term inhalation.

Oral

Type of value: LD50
Species: rat (male/female)

Safety Data Sheet

Arsenal Herbicide

Revision date : 2021/11/03
Version: 5.0

Page: 8/13
(30256051/SDS_CPA_US/EN)

Value: > 5,000 mg/kg

Inhalation

Type of value: LC50
Species: rat (male/female)
Value: > 5.3 mg/l (OECD Guideline 403)
Exposure time: 4 h
An aerosol was tested.

Dermal

Type of value: LD50
Species: rabbit (male/female)
Value: > 2,000 mg/kg

Assessment other acute effects

Assessment of STOT single:
Based on the available information there is no specific target organ toxicity to be expected after a single exposure.

The product has not been tested. The statement has been derived from the properties of the individual components.

Irritation / corrosion

Assessment of irritating effects: May cause slight but temporary irritation to the eyes. May cause slight irritation to the skin.

Skin

Species: rabbit
Result: Slightly irritating.
Method: Primary skin irritation test

Eye

Species: rabbit
Result: non-irritant

Sensitization

Assessment of sensitization: Skin sensitizing effects were not observed in animal studies.

Skin sensitization test

Species: guinea pig
Result: Skin sensitizing effects were not observed in animal studies.

Chronic Toxicity/Effects

Repeated dose toxicity

Assessment of repeated dose toxicity: The product has not been tested. The statement has been derived from the properties of the individual components. No substance-specific organotoxicity was observed after repeated administration to animals.

Genetic toxicity

Assessment of mutagenicity: The product has not been tested. The statement has been derived from the properties of the individual components. Mutagenicity tests revealed no genotoxic potential.

Carcinogenicity

Assessment of carcinogenicity: The product has not been tested. The statement has been derived from the properties of the individual components. The results of various animal studies gave no indication of a carcinogenic effect.

Safety Data Sheet

Arsenal Herbicide

Revision date : 2021/11/03
Version: 5.0

Page: 9/13
(30256051/SDS_CPA_US/EN)

Reproductive toxicity

Assessment of reproduction toxicity: The product has not been tested. The statement has been derived from the properties of the individual components. The results of animal studies gave no indication of a fertility impairing effect.

Teratogenicity

Assessment of teratogenicity: The product has not been tested. The statement has been derived from the properties of the individual components. Animal studies gave no indication of a developmental toxic effect at doses that were not toxic to the parental animals.

Other Information

Misuse can be harmful to health.

Medical conditions aggravated by overexposure

Data available do not indicate that there are medical conditions that are generally recognized as being aggravated by exposure to this substance/product. See SDS section 11 - Toxicological information.

12. Ecological Information

Toxicity

Aquatic toxicity

Assessment of aquatic toxicity:

There is a high probability that the product is not acutely harmful to fish. There is a high probability that the product is not acutely harmful to aquatic invertebrates. Acutely harmful for aquatic plants.

Toxicity to fish

Information on: Imazapyr technical

LC50 (96 h) >100PPM, Oncorhynchus mykiss (static)

LC50 (96 h) >100 ppm, Lepomis macrochirus (static)

Aquatic invertebrates

Information on: Imazapyr technical

EC50 (24 h) > 100 ppm, Daphnia magna

Aquatic plants

Information on: Imazapyr technical

EC50 (96 h) >1 ppm, Selenastrum capricornutum (static)

EC50 (14 d) 24, Lemna gibba

Chronic toxicity to fish

Information on: Imazapyr technical

No observed effect concentration (33 d) 118 mg/l, Pimephales promelas

Chronic toxicity to aquatic invertebrates

Information on: Imazapyr technical

Safety Data Sheet

Arsenal Herbicide

Revision date : 2021/11/03

Version: 5.0

Page: 10/13

(30256051/SDS_CPA_US/EN)

No observed effect concentration (21 d) 97.1 mg/l, Daphnia magna

Assessment of terrestrial toxicity

With high probability not acutely harmful to terrestrial organisms.

Other terrestrial non-mammals

Information on: imazapyr

LC50, Anas platyrhynchos

With high probability not acutely harmful to terrestrial organisms.

LD50 > 100 ug/bee, Apis mellifera

With high probability not acutely harmful to terrestrial organisms.

Persistence and degradability

Assessment biodegradation and elimination (H2O)

The product has not been tested. The statement has been derived from the properties of the individual components.

Elimination information

Not readily biodegradable (by OECD criteria).

Bioaccumulative potential

Assessment bioaccumulation potential

The product has not been tested. The statement has been derived from the properties of the individual components.

Assessment bioaccumulation potential

Information on: Imazapyr technical

Does not accumulate in organisms.

Mobility in soil

Assessment transport between environmental compartments

The product has not been tested. The statement has been derived from the properties of the individual components.

Information on: Imazapyr technical

The substance will not evaporate into the atmosphere from the water surface.

Following exposure to soil, the product trickles away and can - dependant on degradation - be transported to deeper soil areas with larger water loads.

Additional information

Other ecotoxicological advice:

The ecological data given are those of the active ingredient. Do not release untreated into natural waters.

Safety Data Sheet

Arsenal Herbicide

Revision date : 2021/11/03
Version: 5.0

Page: 11/13
(30256051/SDS_CPA_US/EN)

13. Disposal considerations

Waste disposal of substance:

Pesticide wastes are regulated. Improper disposal of excess pesticide, spray mix or rinsate is a violation of federal law. If pesticide wastes cannot be disposed of according to label instructions, contact the State Pesticide or Environmental Control Agency or the Hazardous Waste representative at the nearest EPA Regional Office for guidance.

Container disposal:

Rinse thoroughly at least three times (triple rinse) in accordance with EPA recommendations. Consult state or local disposal authorities for approved alternative procedures such as container recycling. Recommend crushing, puncturing or other means to prevent unauthorized use of used containers.

RCRA:

This product is not regulated by RCRA.

14. Transport Information

Land transport

USDOT

Not classified as a dangerous good under transport regulations

Sea transport

IMDG

Hazard class:	9
Packing group:	III
ID number:	UN 3082
Hazard label:	9, EHS
Marine pollutant:	YES
Proper shipping name:	ENVIRONMENTALLY HAZARDOUS SUBSTANCE, LIQUID, N.O.S. (contains IMAZAPYR)

Air transport

IATA/ICAO

Hazard class:	9
Packing group:	III
ID number:	UN 3082
Hazard label:	9, EHS
Proper shipping name:	ENVIRONMENTALLY HAZARDOUS SUBSTANCE, LIQUID, N.O.S. (contains IMAZAPYR)

Further information

Product may be shipped as non-hazardous in suitable packages containing a net quantity of 5 L or less under the provisions of various regulatory agencies: ADR, RID, ADN: Special Provision 375; IMDG: 2.10.2.7; IATA: A197; TDG: Special Provision 99(2); 49CFR: §171.4 (c) (2) and also the Special Provision 375 in Appendix B which is regulated in China "Regulations Concerning Road Transportation of Dangerous Goods Part 3: Index of dangerous goods name and transportation requirements" (JT/T 617.3)

Safety Data Sheet

Arsenal Herbicide

Revision date : 2021/11/03
Version: 5.0

Page: 12/13
(30256051/SDS_CPA_US/EN)

15. Regulatory Information

Federal Regulations

Registration status:

Crop Protection TSCA, US released / exempt

Chemical TSCA, US blocked / not listed

EPCRA 311/312 (Hazard categories): Refer to SDS section 2 for GHS hazard classes applicable for this product.

Safe Drinking Water & Toxic Enforcement Act, CA Prop. 65:

BASF Risk Assessment, CA Prop. 65:

Based on an evaluation of the product's composition and the use(s), this product does not require a California Proposition 65 Warning.

NFPA Hazard codes:

Health: 1 Fire: 1 Reactivity: 1 Special:

Labeling requirements under FIFRA

This chemical is a pesticide product registered by the Environmental Protection Agency and is subject to certain labeling requirements under federal pesticide law. These requirements differ from the classification criteria and hazard information required for safety data sheets, and workplace labels of non-pesticide chemicals. Following is the hazard information as required on the pesticide label.

CAUTION:

KEEP OUT OF REACH OF CHILDREN.

Avoid contact with the skin, eyes and clothing.

Avoid inhalation of mists/vapours.

16. Other Information

SDS Prepared by:

BASF NA Product Regulations

SDS Prepared on: 2021/11/03

We support worldwide Responsible Care® initiatives. We value the health and safety of our employees, customers, suppliers and neighbors, and the protection of the environment. Our commitment to Responsible Care is integral to conducting our business and operating our facilities in a safe and environmentally responsible fashion, supporting our customers and suppliers in ensuring the safe and environmentally sound handling of our products, and minimizing the impact of our operations on society and the environment during production, storage, transport, use and disposal of our products.

Safety Data Sheet

Arsenal Herbicide

Revision date : 2021/11/03

Page: 13/13

Version: 5.0

(30256051/SDS_CPA_US/EN)

IMPORTANT: WHILE THE DESCRIPTIONS, DESIGNS, DATA AND INFORMATION CONTAINED HEREIN ARE PRESENTED IN GOOD FAITH AND BELIEVED TO BE ACCURATE , IT IS PROVIDED FOR YOUR GUIDANCE ONLY. BECAUSE MANY FACTORS MAY AFFECT PROCESSING OR APPLICATION/USE, WE RECOMMEND THAT YOU MAKE TESTS TO DETERMINE THE SUITABILITY OF A PRODUCT FOR YOUR PARTICULAR PURPOSE PRIOR TO USE. NO WARRANTIES OF ANY KIND, EITHER EXPRESSED OR IMPLIED, INCLUDING WARRANTIES OF MERCHANTABILITY OR FITNESS FOR A PARTICULAR PURPOSE, ARE MADE REGARDING PRODUCTS DESCRIBED OR DESIGNS, DATA OR INFORMATION SET FORTH, OR THAT THE PRODUCTS, DESIGNS, DATA OR INFORMATION MAY BE USED WITHOUT INFRINGING THE INTELLECTUAL PROPERTY RIGHTS OF OTHERS. IN NO CASE SHALL THE DESCRIPTIONS, INFORMATION, DATA OR DESIGNS PROVIDED BE CONSIDERED A PART OF OUR TERMS AND CONDITIONS OF SALE. FURTHER, YOU EXPRESSLY UNDERSTAND AND AGREE THAT THE DESCRIPTIONS, DESIGNS, DATA, AND INFORMATION FURNISHED BY OUR COMPANY HEREUNDER ARE GIVEN GRATIS AND WE ASSUME NO OBLIGATION OR LIABILITY FOR THE DESCRIPTION, DESIGNS, DATA AND INFORMATION GIVEN OR RESULTS OBTAINED, ALL SUCH BEING GIVEN AND ACCEPTED AT YOUR RISK.
END OF DATA SHEET

GROUP 1 HERBICIDE

PULL HERE TO OPEN ►

 **Fusion**®

syngenta®

Herbicide

Postemergence Herbicide for Control of Perennial and Annual Grass Weeds

Active Ingredients:

Fluazifop-P-butyl	
Butyl(R)-2-[4-[[5-(trifluoromethyl)-2-pyridinyl]oxy]phenoxy]propanoate	24.15%
Fenoxaprop-P-ethyl	
(+)-ethyl-2-[4-[6-(chloro-2-benzoxazolyl)oxy]phenoxy]propanoate	6.76%
Other Ingredients*:	69.09%
Total:	100.00%

Contains 2 lbs. (+) isomer (fluazifop-P-butyl) and 0.56 lbs. fenoxaprop-P-ethyl active ingredient per gallon.

*Contains aromatic petroleum distillates.

KEEP OUT OF REACH OF CHILDREN. WARNING/AVISO

Si usted no entiende la etiqueta, busque a alguien para que se la explique a usted en detalle. (If you do not understand the label, find someone to explain it to you in detail.)

See directions for use inside booklet.

EPA Reg. No. 100-1059 EPA Est. No. 11773-IA-01

Product of United Kingdom
Formulated in the USA

SCP 1059A-L1D 1210
334497

2.5 gallons
Net Contents

TM

FIRST AID	
If on skin or clothing	<ul style="list-style-type: none"> • Take off contaminated clothing. • Rinse skin immediately with plenty of water for 15-20 minutes. • Call a poison control center or doctor for treatment advice.
If swallowed	<ul style="list-style-type: none"> • Immediately call a poison control center or doctor. • Do not induce vomiting unless told to do so by a poison control center or doctor. • Do not give any liquid to the person. • Do not give anything by mouth to an unconscious person.
If in eyes	<ul style="list-style-type: none"> • Hold eye open and rinse slowly and gently with water for 15-20 minutes. • Remove contact lenses, if present, after the first 5 minutes, then continue rinsing eye. • Call a poison control center or doctor for treatment advice.
If inhaled	<ul style="list-style-type: none"> • Move person to fresh air. • If person is not breathing call 911 or an ambulance, then give artificial respiration, preferably mouth-to-mouth if possible. • Call a poison control center or doctor for further treatment advice.
NOTE TO PHYSICIAN	
Contains petroleum distillate – vomiting may cause aspiration pneumonia.	
Have the product container or label with you when calling a poison control center or doctor, or going for treatment.	
HOT LINE NUMBER For 24-Hour Medical Emergency Assistance (Human or Animal) or Chemical Emergency Assistance (Spill, Leak, Fire, or Accident) Call 1-800-888-8372	

PRECAUTIONARY STATEMENTS

Hazards to Humans and Domestic Animals

WARNING/AVISO

WARNING. Causes skin irritation. Harmful if absorbed through skin or swallowed. Causes moderate eye irritation. Do not get on skin or on clothing. Avoid contact with eyes. Avoid breathing spray mist. Prolonged or frequently repeated skin contact may cause allergic reactions in some individuals.

Personal Protective Equipment (PPE)

Some materials that are chemical-resistant to this product are listed below. If you want more options, follow the instructions for Category G on an EPA chemical resistance category selection chart.

Applicators and other handlers must wear:

- Coveralls over short-sleeved shirt and short pants
- Chemical-resistant shoes plus socks, and
- Chemical-resistant gloves, such as barrier laminate or Viton®

Follow manufacturer's instructions for cleaning/maintaining PPE. If no such instructions for washables exist, use detergent and hot water. Keep and wash PPE separately from other laundry.

When handlers use closed systems, enclosed cabs, or aircraft in a manner that meets the requirements listed in the Worker Protection Standard (WPS) for agricultural pesticides [40 CFR 170.240(d)(4-6)], the handler PPE requirements may be reduced or modified as specified in the WPS.

continued...

PRECAUTIONARY STATEMENTS *(continued)*

User Safety Recommendations

Users should:

- Wash hands before eating, drinking, chewing gum, using tobacco or using the toilet.
- Remove clothing/PPE immediately if pesticide gets inside. Then wash thoroughly and put on clean clothing.
- Remove PPE immediately after handling this product. Wash the outside of gloves before removing. As soon as possible, wash thoroughly and change into clean clothing.

Environmental Hazards

This product is toxic to fish. Do not apply directly to water, or to areas where surface water is present, or to intertidal areas below the mean high water mark. Do not contaminate water when disposing of equipment washwater or rinsate. Do not apply when weather conditions favor drift from target area.

Ground Water Advisory

Fluazifop-P-butyl is known to leach through soil into ground water under certain conditions as a result of label use. This chemical may leach into ground water if used in areas where soils are permeable, particularly where the water table is shallow.

This product may impact surface water quality due to runoff of rain water. This is especially true for poorly draining soils and soils with shallow ground water.

This product is classified as having high potential for reaching surface water via runoff for several months or more after application. A level, well-maintained vegetative buffer strip between areas to which this product is applied and surface water features such as ponds, streams, and springs will reduce the potential loading of fluazifop-p-butyl from runoff water and sediment. Runoff of this product will be reduced by avoiding applications when rainfall is forecasted to occur within 48 hours.

Physical and Chemical Hazards

Combustible. Do not use or store near heat or open flame.

CONDITIONS OF SALE AND LIMITATION OF WARRANTY AND LIABILITY

NOTICE: Read the entire Directions for Use and Conditions of Sale and Limitation of Warranty and Liability before buying or using this product. If the terms are not acceptable, return the product at once, unopened, and the purchase price will be refunded.

The Directions for Use of this product must be followed carefully. It is impossible to eliminate all risks inherently associated with the use of this product. Crop injury, ineffectiveness or other unintended consequences may result because of such factors as manner of use or application, weather or crop conditions, presence of other materials or other influencing factors in the use of the product, which are beyond the control of SYNGENTA CROP PROTECTION, LLC or Seller. To the extent permitted by applicable law, Buyer and User agree to hold Syngenta and Seller harmless for any claims relating to such factors.

SYNGENTA warrants that this product conforms to the chemical description on the label and is reasonably fit for the purposes stated in the Directions for Use, subject to the inherent risks referred to above, when used in accordance with directions under normal use conditions. To the extent permitted by applicable law: (1) this warranty does not extend to the use of this product contrary to label instructions or under conditions not reasonably foreseeable to or beyond the control of Seller or SYNGENTA, and, (2) Buyer and User assume the risk of any such use. TO THE EXTENT PERMITTED BY APPLICABLE LAW, SYNGENTA MAKES NO WARRANTIES OF MERCHANTABILITY OR OF FITNESS FOR A PARTICULAR PURPOSE NOR ANY OTHER EXPRESS OR IMPLIED WARRANTY EXCEPT AS WARRANTED BY THIS LABEL.

To the extent permitted by applicable law, in no event shall Syngenta be liable for any incidental, consequential or special damages resulting from the use or handling of this product. **TO THE EXTENT PERMITTED BY APPLICABLE LAW, THE EXCLUSIVE REMEDY OF THE USER OR BUYER, AND THE EXCLUSIVE LIABILITY OF SYNGENTA AND SELLER FOR ANY AND ALL CLAIMS, LOSSES, INJURIES OR DAMAGES (INCLUDING CLAIMS BASED ON BREACH OF WARRANTY, CONTRACT, NEGLIGENCE, TORT, STRICT LIABILITY OR OTHERWISE) RESULTING FROM THE USE OR HANDLING OF THIS PRODUCT, SHALL BE THE RETURN OF THE PURCHASE PRICE OF THE PRODUCT OR, AT THE ELECTION OF SYNGENTA OR SELLER, THE REPLACEMENT OF THE PRODUCT.**

SYNGENTA and Seller offer this product, and Buyer and User accept it, subject to the foregoing Conditions of Sale and Limitation of Warranty and Liability, which may not be modified except by written agreement signed by a duly authorized representative of SYNGENTA.

DIRECTIONS FOR USE

It is a violation of federal law to use this product in a manner inconsistent with its labeling. This labeling must be in the possession of the user at the time of application.

Do not apply this product in a way that will contact workers or other persons, either directly or through drift. Only protected handlers may be in the area during application. For any requirements specific to your State or Tribe, consult the agency responsible for pesticide regulation.

AGRICULTURAL USE REQUIREMENTS

Use this product only in accordance with its labeling and with the Worker Protection Standard, 40 CFR part 170. This Standard contains requirements for the protection of agricultural workers on farms, forests, nurseries, and greenhouses, and handlers of agricultural pesticides. It contains requirements for training, decontamination, notification, and emergency assistance. It also contains specific instructions and exceptions pertaining to the statements on this label about personal protective equipment (PPE), and restricted-entry interval. The requirements in this box only apply to uses of this product that are covered by the Worker Protection Standard.

Do not enter or allow worker entry into treated areas during the restricted-entry interval (REI) of 24 hours.

PPE required for early entry to treated areas that is permitted under the Worker Protection Standard and that involves contact with anything that has been treated, such as plants, soil, or water, is:

- Coveralls
- Chemical-resistant gloves, such as barrier laminate or Viton
- Shoes plus socks

PRODUCT INFORMATION

Read all label directions before using.

Fusion Herbicide is a selective postemergence herbicide for control of annual and perennial grass weeds in soybeans, and cotton. Fusion Herbicide provides effective control of grass weeds in conventional tillage, minimum tillage, and no-till plantings. Fusion Herbicide may be applied for control of emerged grass weeds before, during or after planting or after harvest of soybeans or cotton. Fusion Herbicide does not control broadleaf weeds or sedges (nutgrass).

Fusion Herbicide is a systemic herbicide which moves from the treated foliage into the shoots, roots, rhizomes, stolons, and growing points (meristematic regions) of treated grass weeds.

Rainfastness – Since Fusion Herbicide is rapidly absorbed by the grass foliage, rain or irrigation occurring one hour or more after application will not affect the activity of Fusion Herbicide. When tank mixing with broadleaf herbicides, observe the rainfast statement of the most restrictive label.

Control Symptoms – Growth of treated grass weeds stops soon after application. Symptoms include loss of vigor, yellowing and/or reddening, and eventual death of the treated grass plant. Symptoms are generally observed within one week after treatment, depending on grass weed species and environmental conditions.

INFORMATION ON WEED RESISTANCE

Naturally occurring biotypes of certain grass species with resistance to this herbicide and related products (same mode of action) are known to exist. Selection of resistant biotypes, through repeated use of these herbicides, may result in control failures.

If poor performance cannot be attributed to adverse weather conditions or improper application methods, a resistant biotype may be present. In such a case, additional treatments with this herbicide or related products are not recommended. Consult your local company representative or agricultural advisor for assistance.

APPLICATION DIRECTIONS

Thorough coverage of all grass weed foliage is important for good activity. Optimum weed control is achieved when young actively growing grass weeds are treated that are not under stress from low soil moisture, extreme temperatures, low soil fertility, mechanical, or chemical injury.

Spray Additives - Only crop oil concentrate, nonionic surfactants and other adjuvants cleared for use on growing crops may be used in spray mixture. Under dry conditions, crop oil concentrate is the preferred adjuvant.

Always Add One of the Following:

- **Crop Oil Concentrate (COC)** – Add a non-phytotoxic crop oil concentrate or a once-refined vegetable oil concentrate containing 15-20% approved emulsifier, at 0.5-1% v/v (0.5-1 gal./100 gals.) in the finished spray volume for ground applications. For aerial applications, add 1 pint of crop oil concentrate per acre.
- **Nonionic Surfactant (NIS)** – Add nonionic surfactant containing at least 75% surface-active agent, at 0.25-0.5% v/v (1-2 qts./100 gals.) in the finished spray volume for ground application. For aerial application, add 1 pint of surfactant per acre.
- **Other Adjuvants** - Adjuvants other than COC or NIS may be used providing the product meets the following criteria:
 1. Contains only EPA exempt ingredients.
 2. Is nonphytotoxic to the target crop.
 3. Is compatible in mixture. (May be established through a jar test.)
 4. Is supported locally for use with Fusion on the target crop through proven field trials and through university and extension recommendations.

Always refer to the product label and follow directions concerning rates, target crops, environmental effect such as drought or weed stress, and use in tank mix with other labeled pesticides.

DIRECTIONS FOR GROUND APPLICATION

Nozzle Selection - The use of flat fan nozzles will result in the most effective application of Fusion Herbicide. Flood nozzles are generally not as good as flat fans since they produce large uneven droplets. The use of nozzles other than flat fans may result in reduced grass control due to inadequate coverage. Do not apply Fusion Herbicide with recirculating sprayers, rope-wick applicators, controlled droplet applicators (CDA) or any similar devices.

Spray Volume and Pressure - Use sufficient spray volume and pressure to ensure complete coverage of the target grasses. Apply in 5-40 gallons per acre of spray mixture with spray pressures of 30-60 psi at the nozzle tip. When grass foliage is dense, use 60 psi and a minimum of 20 gallons per acre to ensure coverage of weed foliage.

Band Applications - Use a minimum of two nozzles, one directed to each side of the planted row. Application with a single nozzle directed over the top of the row is not recommended. Cultivation of untreated areas may be needed following band applications.

When making band applications and cultivating in the same operation, position nozzles in advance of the cultivation device. This will reduce dust in the spray area. Dust can intercept the spray, reducing weed coverage resulting in less than adequate weed control.

Calculate the amount of herbicide and water volume needed for band treatment by the following formulas:

$$\frac{\text{Band width in inches}}{\text{row width in inches}} \times \text{broadcast rate per acre} = \text{Band herbicide rate per acre}$$

$$\frac{\text{Band width in inches}}{\text{row width in inches}} \times \text{broadcast volume per acre} = \text{Band water volume per acre}$$

Band applications to perennial grasses are not recommended, as reinfestation of the treated band from the untreated middle may result.

Spot Treatments – Mix Fusion Herbicide and crop oil concentrate or nonionic surfactant with water according to the amounts shown below. Spray to obtain thorough coverage, but do not spray to runoff. Re-treat if necessary.

Table 1. Spot Spray Mixing Directions

To Make This Spray Volume	Add These Amounts		
	Fusion	Crop Oil Concentrate	OR Nonionic Surfactant
1 gallon	³ / ₄ fl. oz. (1 ¹ / ₂ tbsp.)	1 ¹ / ₂ fl. oz.	¹ / ₂ fl. oz.
10 gallons	6.5 fl. oz.	13 fl. oz.	3 fl. oz.
25 gallons	1 pt.	1 qt.	¹ / ₂ pt.
50 gallons	1 qt.	2 qts.	1 pt.

Chemigation - Do not apply Fusion Herbicide through any type of irrigation system.

DIRECTIONS FOR AERIAL APPLICATION

Use sufficient spray volume to ensure complete coverage of target grasses. A minimum of 5 gallons per acre should be applied. When grass foliage is dense, use a minimum of 10 gallons per acre to ensure coverage of weed foliage.

Application Timing - Best control of susceptible grasses is obtained when Fusion Herbicide is applied to actively growing grasses before they exceed the listed growth stages shown on this label. Refer to Tables 2, 3, 4 and 5 for specific directions on use rates and weed growth stages.

Cultivation - Cultivation of treated grasses is not recommended within 7 days prior to or within 7 days after application of Fusion Herbicide as weeds may be put under stress resulting in reduced weed control. Timely cultivation 2-3 weeks after applying Fusion Herbicide may assist weed control.

Spray Drift Management

Avoiding spray drift at the application site is the responsibility of the applicator. The interaction of many equipment and weather-related factors determine the potential for spray drift. The applicator and the grower are responsible for considering all these factors when making decisions. The following drift management requirements must be followed to avoid off-target drift movement from aerial applications to agricultural field crops. These requirements do not apply to forestry applications, public health uses or to applications using dry formulations.

1. The distance of the outer most nozzles on the boom must not exceed ³/₄ the length of the wingspan or rotor.
2. Nozzles must always point backward parallel with the air stream and never be pointed downwards more than 45 degrees. Where states have more stringent regulations, they should be observed.

The applicator should be familiar with and take into account the information covered in the Aerial Drift Reduction Advisory Information.

Importance of Droplet Size

The most effective way to reduce drift potential is to apply large droplets. The best drift management strategy is to apply the largest droplets that provide sufficient coverage and control. Applying larger droplets reduces drift potential, but will not prevent drift if applications are made improperly, or under unfavorable environmental conditions (see Wind, Temperature and Humidity, and Temperature Inversion section of this label).

Controlling Droplet Size

- **Volume** - Use high flow rate nozzles to apply the highest practical spray volume. Nozzles with higher rated flows produce larger droplets.
- **Pressure** - Use the lower spray pressures recommended for the nozzle. Higher pressure reduces droplet size and does not improve canopy penetration. When higher flow rates are needed, use higher flow rate nozzles instead of increasing pressure.
- **Number of Nozzles** - Use the minimum number of nozzles that provide uniform coverage.
- **Nozzle Orientation** - Orienting nozzles so that the spray is released backwards, parallel to the airstream will produce larger droplets than other orientations. Significant deflection from the horizontal will reduce droplet size and increase drift potential.
- **Nozzle Type** - Use a nozzle type that is designed for the intended application. With most nozzle types, narrower spray angles produce larger droplets. Consider using low-drift nozzles. Solid stream nozzles oriented straight back produce larger droplets than other nozzle types.
- **Boom Length** - For some use patterns, reducing the effective boom length to less than $\frac{3}{4}$ of the wingspan or rotor length may further reduce drift without reducing swath width.
- **Application** - Applications should not be made at a height greater than 10 feet above the top of the largest plants unless a greater height is required for aircraft safety. Making applications at the lowest height that is safe reduces exposure of droplets to evaporation and wind.

Swath Adjustment

When applications are made with a cross-wind, the swath will be displaced downwind. Therefore, on the up and downwind edges of the field, the applicator must compensate for this displacement by adjusting the path of the aircraft upwind. Swath adjustment distance should increase, with increasing drift potential (higher wind, smaller drops, etc.).

Wind

Drift potential is lowest between wind speeds of 2-10 mph. However, many factors, including droplet size and equipment type determine drift potential at any given speed. Application should be avoided below 2 mph due to variable wind direction and high inversion potential. Note: Local terrain can influence wind patterns. Every applicator should be familiar with local wind patterns and how they affect drift.

Temperature and Humidity

When making applications in low relative humidity, set up equipment to produce larger droplets to compensate for evaporation. Droplet evaporation is most severe when conditions are both hot and dry.

Temperature Inversions

Applications should not occur during a temperature inversion, because drift potential is high. Temperature inversions restrict vertical air mixing, which causes small suspended droplets to remain in a concentrated cloud. This cloud can move in unpredictable directions due to the light variable winds common during inversions. Temperature inversions are characterized by increasing temperatures with altitude and are common on nights with limited cloud cover and light to no wind. They begin to form as the sun sets and often continue into the morning. Their presence can be indicated by ground fog; however, if fog is not present, inversions can also be identified by the movement of smoke from a ground source or an aircraft smoke generator. Smoke that layers and moves laterally in a connected cloud (under low wind conditions) indicates an inversion, while smoke that moves upwards and rapidly dissipates indicates good vertical air mixing.

Sensitive Areas

The pesticide should only be applied when the potential for drift to adjacent sensitive areas (e.g., residential areas, bodies of water, known habitat for threatened or endangered species, non-target crops) is minimal (e.g. when wind is blowing away from the sensitive areas).

PRODUCT USE PRECAUTIONS

- Apply to actively growing grasses. Avoid application to grasses which are stressed due to moisture, temperature, low soil fertility, mechanical or chemical injury.
- Apply at the directed rate to grasses at the listed growth stages as outlined in Tables 2, 3, 4 and 5.
- Apply when the first grass weed species in a mixed grass weed population reaches the recommended growth stage for treatment. Use the highest recommended rate for grasses in that population.
- Where irrigation is used as part of normal cropping practice, best results are usually obtained when Fusion Herbicide is applied within 7 days after irrigation.
- Best perennial grass control can be obtained if rhizomes or stolons are cut up by preplant tillage practices (disking, plowing, etc.) to stimulate maximum emergence of grass shoots.
- Do not plant rotational grass crops such as corn, sorghum, and cereals within 60 days of last application of Fusion Herbicide.
- Avoid drift to all other crops and nontarget areas. Grass crops are highly susceptible to Fusion Herbicide. Avoid application when wind velocity exceeds 15 mph. Do not make ground or aerial applications during temperature inversions.
- Tank mixes of Fusion Herbicide with other pesticides, liquid fertilizers or other additives except as specified on this label or on approved Syngenta supplemental labels may result in tank mix incompatibility, unsatisfactory performance and/or crop injury.
- Thoroughly clean spray tank with water and a commercial tank cleaner before and after each use.
- Do not apply Fusion Herbicide if rainfall is expected within 1 hour.

SPECIFIC RESTRICTIONS FOR SOYBEANS AND COTTON

- Do not apply a total of more than 24 oz. (0.375 lbs. ai/A) of Fusion Herbicide per acre per season to soybeans and cotton.
- Do not apply to cotton after boll set.
- Do not harvest cotton within 90 days of Fusion application.
- Make the last Fusion Herbicide application to soybeans before bloom.
- Do not graze or harvest for forage or hay.

DIRECTIONS FOR ANNUAL AND PERENNIAL GRASS WEED CONTROL IN SOYBEANS AND COTTON – REGION A

SOYBEANS

Fusion Herbicide may be applied in the following states: Alabama, Arkansas, Connecticut, Delaware, Florida, Georgia, Illinois, Indiana, Iowa, Kansas, Kentucky, Louisiana, Maine, Maryland, Massachusetts, Michigan, Minnesota, Mississippi, Missouri, Nebraska, New Hampshire, New Jersey, New York, North Carolina, North Dakota, Ohio, Oklahoma (east of Interstate 35), Pennsylvania, Rhode Island, South Carolina, South Dakota, Tennessee, Texas (east of Interstate 35), Vermont, Virginia, West Virginia, and Wisconsin.

COTTON

Fusion Herbicide may be applied in the following states: Alabama, Arkansas, Florida, Georgia, Louisiana, Mississippi, Missouri, North Carolina, Oklahoma (east of Interstate 35), South Carolina, Tennessee, Texas (east of Interstate 35), and Virginia.

Table 2. Fusion Herbicide Annual Grass Control Use Rate Directions in Soybeans and Cotton - Region A

Annual Grass Species ¹	Ht. (In.)	Special Fusion Rate When Used Alone ² (fl. oz./A)	Fusion Rate When Used Alone (fl. oz./A)	Fusion Rate When Tank Mixed ² (fl. oz./A)
Barnyardgrass	2-4	6	8	8-12
Broadleaf signalgrass	2-4	-	8-10	10-12
Crabgrass	1-4	-	8	8-12
Downy Brome	2-6	-	6	6-10
Fall Panicum	2-6	-	8	8-12
Field Sandbur	2-4	-	8	8-12
Foxtails				
Giant foxtail	2-8	6	7	7-12
Green foxtail	2-4	6	8	8-12
Yellow foxtail	2-4	6	8	8-12
Goosegrass	2-4	-	8	8-12
Italian Ryegrass	2-4	-	8	8-12
Itchgrass	4-24	-	6	6-10
Johnsongrass, seedling	2-8	-	6	6-10
Junglerice	2-3	-	8	8-12
Red rice	0.5-3	-	10-12	10-12
Shattercane	6-12	-	6	6-10
Sorghum alnum	6-12	-	6	6-10
Southern sandbur	2-6	-	8	8-12
Texas Panicum	2-8	-	8	8-12
Volunteer Cereals				
V. Barley	2-6	-	8	8-12
V. Corn ^{3,4}	12-24	4	6	6-10
V. Milo	6-12	-	6	6-10
V. Oats	2-6	-	8	8-12
V. Rye	2-6	-	8	8-12
V. Wheat	2-6	-	8	8-12
Wild Oats	2-6	-	8	8-12
Wild Proso Millet	4-8	-	6	6-10
Witchgrass	2-4	-	8	8-12
Woolly Cupgrass	2-4	-	8	8-12

¹Retreatment at the listed rate may be needed to control later germinating grasses or if regrowth occurs.

²The lowest rate of Fusion Herbicide listed above may be used under the following conditions:

- Application under favorable soil moisture and humidity conditions, normally within a few days after rainfall or irrigation. Avoid extreme air temperatures.
- Application at earliest growth stages indicated on rate tables.
- Application in highly competitive crop stands such as narrow row or drilled soybeans, or where cultivation is planned.
- Application to light or moderate weed densities.
- Application with 1% v/v crop oil concentrate only.

If the conditions above do not exist, use the high rate for the species indicated.

³Fusion will provide suppression of Sethoxydim resistant volunteer corn.

⁴Includes control of Roundup Ready® (glyphosate-tolerant), LibertyLink® and IMI-Corn® volunteer corn.

Table 3. Fusion Herbicide Perennial Grass Control Use Rate Directions In Soybeans and Cotton – Region A

Perennial Grass Species	Application	Ht. (In.)	Rate (fl. oz./A)
Bermudagrass ¹	1st	4-8 (Runner)	12
	2nd	4-8	8
Quackgrass ²	1st	6-10	12
	2nd	10	8
Rhizome johnsongrass ³	1st	8-18	10-12
	2nd	6-12	8
Wirestem muhly ⁴	1st/2nd	4-12	10-12

¹Make second application to bermudagrass if regrowth occurs (usually about 4 weeks after first application). Bermudagrass control may be improved by directing the spray beneath the crop canopy. To improve coverage, make applications in a minimum of 15 gallons per acre.

²Make second application 2-3 weeks after the first, but before the quackgrass exceeds 10 inches in height. Always use 1% v/v crop oil concentrate.

³Make first application before the boot stage. In eastern Oklahoma, the Brazos Bottoms, the Blacklands, Coastal Bend and Rio Grande areas of eastern Texas, make the first application at 8-12 inches. If new shoots emerge or regrowth occurs, make a second application at 4-6 inches.

⁴Make second application if regrowth occurs.

RESCUE APPLICATION IN SOYBEANS

Fusion Herbicide applied at 8-14 fl. oz./A may be used to control giant foxtail, wild proso millet and woolly cupgrass up to 16 inches in height. Applications must be made prior to soybean bloom. Use 12-14 fl. oz./A if grasses appear stressed due to drought, unfavorable temperatures and/or low soil fertility. Do not tank mix Fusion with broadleaf herbicides for rescue applications.

DIRECTIONS FOR ANNUAL AND PERENNIAL GRASS WEED CONTROL IN COTTON – REGION B

New Mexico, Oklahoma (West of Interstate 35), and Texas (West of Interstate 35).

Table 4. Fusion Herbicide Annual Grass Control Use Rate Directions – Region B

Annual Grass Species ¹	Ht. (In.)	No. of Leaves Not to Exceed	Rate(s) fl. oz./A
Barnyardgrass	1-2	3	12
Canarygrass, Littleseed	2-4	4	12
Crabgrass, Large	1-2	3	12
Crabgrass, Smooth ²	1-2	4	12
Johnsongrass, seedling	2-4	3	8
Junglerice	2-3	3	12
Panicums			
Fall Panicum ²	2-6	6	12
Texas Panicum ²	8	8	12
Rabbitfootgrass	2-4	4	12
Volunteer Cereals			
V. Barley	2-4	3	12
V. Corn	12-18	6	12
V. Milo	2-4	4	12
V. Oats	2-4	3	12
V. Wheat	2-4	3	12
Wild Oats ²	2-4	4	12

¹Retreatment at the listed rate may be needed to control late germinating grasses or if regrowth occurs.

²Recommended for use in Oklahoma and Texas on these species.

Table 5. Fusion Herbicide Perennial Grass Control Use Rate Directions – Region B

For best results, apply Fusion 3 days before to 7 days after irrigation.			
Perennial Grass Species	Application	Ht. (In.)	Rate fl. oz./A
Bermudagrass ^{1,2}	1st	4-8 (runner length)	16-24
Rhizome johnsongrass ^{3,4}	1st	12-18	10-24

¹Make second application to bermudagrass if regrowth occurs. (Usually about 4 weeks after first application.) Bermudagrass control may be improved by directing the spray beneath the crop canopy. To improve coverage, make applications in a minimum of 20 gallons per acre. Do not apply more than 24 oz. in one season.

²In Oklahoma (west of Interstate 35) and Texas (west of Interstate 35) under good soil moisture and favorable growing conditions, make applications at reduced rates of 12-16 fl. oz./A.

³Make first application before the boot stage. If new shoots emerge or regrowth occurs, make a second application. (Usually about 4 weeks after the first application.) Do not apply more than 24 oz. in one season.

⁴In Oklahoma (west of Interstate 35) and Texas (west of Interstate 35) under good soil moisture and favorable growing conditions, make the first application to 8-18 inch johnsongrass at a reduced rate of 12 fl. oz./A. Make the second application to 6-12 inch johnsongrass at a rate of 12 fl. oz./A.

TANK MIX AND SEQUENTIAL APPLICATIONS FOR SOYBEANS

Fusion can be used sequentially or in tank mix with one or more of the following: Basagran®, Boundary®, Canopy®**, Classic®**, Cobra®, FirstRate®**, Flexstar®, Flexstar GT, Gramoxone Inteon®, Harmony®**, Ignite®, Prefix®, Prowl®, Pursuit®, Reflex®, Scepter®**, Storm®, Synchrony®**, Roundup® brands, Touchdown® brands, Ultra Blazer®, 2,4-D (LVE)***.

*Fusion at 4 oz./A plus Pursuit for volunteer corn and shattercane only.

**If the grass population consists mainly of yellow foxtail, barnyardgrass, woolly cupgrass, field sandbur, smooth or large crabgrass, Texas panicum, broadleaf signalgrass or red rice and conditions are less than optimum (see footnote 2, Table 2), a sequential application is recommended to provide satisfactory performance.

***Fusion + 2,4-D (LVE) tank mix at 4-8 fl. oz./A + 0.5 lb. AE/A may be used as a preplant treatment for the control of giant foxtail and fall panicum and broadleaf weeds as specified on the 2,4-D label. Use the higher rate of Fusion on grasses greater than 2 inches. The tank mix should be used with a crop oil concentrate.

Under certain conditions, the mixture of Fusion with one or more of the above-mentioned broadleaf herbicides may cause a reduction in grass activity.

For sequential applications, allow 2 to 3 days after the application of Fusion before applying a broadleaf herbicide or mixture. In case the broadleaf herbicide or mixture is applied first, apply Fusion when the grass weeds begin to develop new leaves (generally around 7 days).

Liquid nitrogen fertilizer (28% UAN or similar) may be added to the spray mixture up to 4 gallons per 100 gallons (4% v/v). Dry nitrogen fertilizer (ammonium sulfate) may be added up to 4 lbs. product per acre. Liquid and dry nitrogen fertilizers should not be used as a substitute for crop oil concentrate or nonionic surfactant in the spray mixture.

Always read and follow the application directions, restrictions and limitations for all products whether used alone or in a tank mix. The most restrictive labeling of any product used applies in tank mixtures.

Note: Tank mix applications sometimes have resulted in reduced grass weed control and possible increases in crop injury as compared to the products used alone. If grass regrowth occurs following an application of the tank mix or an additional flush of grasses emerge, make a second application of Fusion Herbicide to actively growing grass weeds, as per the label recommendations. When perennial grasses are the predominant grass to be controlled, a sequential application is recommended. Follow the directions for sequential applications of Fusion Herbicide and the appropriate broadleaf herbicide.

Glyphosate-Tolerant Soybeans (including Roundup Ready Soybeans) Tank Mix

Fusion Herbicide can be tank mixed with glyphosate products (such as Touchdown or Roundup brands) for control of volunteer corn including volunteer glyphosate-resistant corn in glyphosate-tolerant soybeans (including Roundup Ready soybeans). Apply Fusion Herbicide at 4-6 fl. oz./A. Use the 4 fl. oz./A rate only under the following conditions:

- Application under favorable soil moisture and humidity conditions which normally occur within a few days after rainfall or irrigation.
- Avoid extreme air temperatures.
- Application when volunteer corn is less than 12 inches tall.
- Application with 0.25% v/v crop oil concentrate (COC). This COC is in addition to the additives required by the glyphosate product.

Use the higher rate if the above conditions do not exist.

Application of this tank mix on soybean varieties that have not been genetically modified to tolerate glyphosate-based products will result in severe injury or plant death.

TANK MIX AND SEQUENTIAL APPLICATIONS FOR COTTON

Tank mixes with other herbicides labeled for use in cotton are not recommended unless specified on this label or other supplemental labeling.

Glyphosate-Tolerant Cotton (including Roundup Ready Cotton) Tank Mix

Fusion Herbicide can be tank mixed with glyphosate products (such as Touchdown or Roundup brands) for control of volunteer corn including volunteer glyphosate-resistant corn in glyphosate-tolerant cotton (including Roundup Ready cotton). Apply Fusion Herbicide at 4-6 fl. oz./A. Use the 4 fl. oz./A rate only under the following conditions:

- Application under favorable soil moisture and humidity conditions which normally occur within a few days after rainfall or irrigation.
- Avoid extreme air temperatures.
- Application when volunteer corn is less than 12 inches tall.
- Application with 0.25% v/v crop oil concentrate (COC). This COC is in addition to the additives required by the glyphosate product.

Use the higher rate if the above conditions do not exist.

Application of this tank mix on cotton varieties that have not been genetically modified to tolerate glyphosate based products will result in severe injury or plant death.

Sequential Applications

Fusion Herbicide can be used sequentially with other labeled cotton herbicides. For sequential applications, allow 2 to 3 days after the application of Fusion Herbicide before applying a broadleaf herbicide or mixture. In situations where the broadleaf herbicide or mixture is applied first, apply Fusion Herbicide when the grass weeds begin to develop new leaves (generally around 7 days).

Cotton Tank Mix and Sequential Use Precautions

- Always read and follow the directions, restrictions and limitations for all products whether used alone, sequentially or in a tank mix. The most restrictive labeling of any product used applies.

APPENDIX

Scientific names are listed for those weeds referred to in the Fusion Herbicide label.

COMMON NAME	SCIENTIFIC NAME
Barnyardgrass	<i>Echinochloa crus-galli</i>
Broadleaf signalgrass	<i>Brachiaria platyphylla</i>
Brome, Downy	<i>Bromus tectorum</i>
Crabgrass, Large	<i>Digitaria sanguinalis</i>
Crabgrass, Smooth	<i>Digitaria ischaemum</i>
Crabgrass, Southern	<i>Digitaria ciliaris</i>
Crabgrass, Tropical	<i>Digitaria bicornis</i>
Fall Panicum	<i>Panicum dichotomiflorum</i>
Field Sandbur	<i>Cenchrus incertus</i>
Foxtail, Giant	<i>Setaria faberi</i>

COMMON NAME	SCIENTIFIC NAME
Foxtail, Green	<i>Setaria viridis</i>
Foxtail, Yellow	<i>Setaria pumila</i>
Goosegrass	<i>Eleusine indica</i>
Itchgrass	<i>Rottboellia exaltata</i>
Johnsongrass, Seedling	<i>Sorghum halapense</i>
Junglerice	<i>Echinochloa colonum</i>
Quackgrass	<i>Elymus repens</i>
Red Rice	<i>Oryza sativa</i>
Shattercane	<i>Sorghum bicolor</i>
Sorghum Almum	<i>Sorghum almum</i>
Southern Sandbur	<i>Cenchrus echinatus</i>
Southwestern cupgrass	<i>Eriochloa gracilis</i>
Texas Panicum	<i>Panicum texanum</i>
Volunteer Cereals	
V. Barley	<i>Hordeum vulgare</i>
V. Corn	<i>Zea mays</i>
V. Milo	<i>Sorghum bicolor</i>
V. Oats	<i>Avena sativa</i>
V. Rye	<i>Secale cereale</i>
V. Wheat	<i>Triticum aestivum</i>
Wild Oats	<i>Avena fatua</i>
Wild Proso Millet	<i>Panicum miliaceum</i>
Wirestem Muhly	<i>Muhlenbergia frondosa</i>
Witchgrass	<i>Panicum capillare</i>
Wooly cupgrass	<i>Eriochloa villosa</i>

STORAGE AND DISPOSAL

Do not contaminate water, food or feed by storage and disposal.

Pesticide Storage

Store in original container only. Keep container closed when not in use. Do not store near food or feed. In case of spill or leak on floor or paved surfaces, soak up with sand, earth or synthetic absorbent. Remove to chemical waste area.

Pesticide Disposal

Open dumping is prohibited. Pesticide wastes are toxic. Improper disposal of excess pesticide, spray mixture or rinsate is a violation of federal law. If these wastes cannot be disposed of by use according to label instructions, contact your State Pesticide or Environmental Control Agency or the Hazardous Waste Representative at the nearest EPA Regional Office for guidance.

Container Handling [less than 5 gallons]

Non-refillable container. Do not reuse or refill this container. Offer for recycling if available. Triple-rinse container (or equivalent) promptly after emptying. Triple rinse as follows: Empty the remaining contents into application equipment or a mix tank and drain for 10 seconds after the flow begins to drip. Fill the container 1/4 full with water and recap. Shake for 10 seconds. Pour rinsate into application equipment or a mix tank or store rinsate for later use and disposal. Drain for 10 seconds after the flow begins to drip. Repeat this procedure two more times. Then offer for recycling if available or puncture and dispose of in a sanitary landfill, by incineration or, if allowed by state and local authorities, by burning. If burned, stay out of smoke.

Container Handling [Bulk/Mini-bulk]

Refillable container. Refill this container with pesticide only. Do not use this container for any other purpose. Cleaning the container before final disposal is the responsibility of the person disposing of the container. Cleaning before refilling is the responsibility of the refiller. To clean container before final disposal, empty the remaining contents from this container into application equipment or mix tank. Fill the container about 10 percent full with water. Agitate vigorously or recirculate water with the pump for 2 minutes. Pour or pump rinsate into application equipment or rinsate collection system. Repeat this rinsing procedure two more times.

CONTAINER IS NOT SAFE FOR FOOD, FEED OR DRINKING WATER.

Boundary®, Fusion®, Flexstar®, Flexstar® GT, Gramoxone Inteon®, Prefix®, Reflex®, Touchdown®, the ALLIANCE FRAME  the SYNGENTA Logo and the PURPOSE ICON  are Trademarks of a Syngenta Group Company.

Basagran®, Prowl®, Pursuit®, Scepter® and Storm® trademarks of BASF Corporation.

FirstRate® and Garlon® trademarks of Dow Agro Sciences.

Canopy®, Classic®, Escort®, Harmony®, Synchrony®, Telar® and Viton® trademarks of E. I. duPont de Nemours & Co., Inc.

Cobra® trademark of Valent USA Corporation.

Ignite® and LibertyLink® trademarks of Bayer CropScience

IMI-Corn® trademark of American Cyanamid Company

Roundup® and Roundup Ready® trademarks of Monsanto Company.

Ultra Blazer® trademark of United Phosphorus, Inc.

©2011 Syngenta

For non-emergency (e.g., current product information), call
Syngenta Crop Protection at 1-800-334-9481

Manufactured for:
Syngenta Crop Protection, LLC
P.O. Box 18300
Greensboro, North Carolina 27419-8300

**SCP 1059A-L1D 1210
334497**

GROUP 1 HERBICIDE



Herbicide

Postemergence Herbicide for Control of Perennial and Annual Grass Weeds

Active Ingredients:

Fluazifop-P-butyl	
Butyl(R)-2-[4-[5-(trifluoromethyl)-2-pyridinyl]oxy]phenoxy]propanoate	24.15%
Fenoxaprop-P-ethyl (+)-ethyl-2-[4-[6-(chloro-2-benzoxazolyl)oxy]phenoxy]propanoate	6.76%
Other Ingredients*	69.09%
Total:	100.00%

Contains 2 lbs. (+) isomer (fluazifop-P-butyl) and 0.56 lbs. fenoxaprop-P-ethyl active ingredient per gallon.

*Contains aromatic petroleum distillates.

EPA Reg. No. 100-1059
EPA Est. 11773-IA-01

AGRICULTURAL USE REQUIREMENTS

Use this product only in accordance with its labeling and with the Worker Protection Standard, 40 CFR part 170. Refer to supplemental labeling under "Agricultural Use Requirements" in the Directions for Use section for information about this standard.

Fusion® and the Syngenta logo are trademarks of a Syngenta Group Company.

©2011 Syngenta

Manufactured by:
Syngenta Crop Protection, LLC
P.O. Box 18300
Greensboro, North Carolina 27419-8300

SCP 1059A-L1D 1210
334497

2.5 gallons

Net Contents

KEEP OUT OF REACH OF CHILDREN. WARNING/ AVISO

Si usted no entiende la etiqueta, busque a alguien para que se la explique a usted en detalle. (If you do not understand the label, find someone to explain it to you in detail.)

Precautionary Statements Hazards to Humans and Domestic Animals WARNING/AVISO

WARNING. Causes skin irritation. Harmful if absorbed through skin or swallowed. Causes moderate eye irritation. Do not get on skin or on clothing. Avoid contact with eyes. Avoid breathing spray mist. Prolonged or frequently repeated skin contact may cause allergic reactions in some individuals.

FIRST AID

If on skin or clothing: Take off contaminated clothing. Rinse skin immediately with plenty of water for 15-20 minutes. Call a poison control center or doctor for treatment advice. **If swallowed:** Immediately call a poison control center or doctor. Do not induce vomiting unless told to do so by a poison control center or doctor. Do not give any liquid to the person. Do not give anything by mouth to an unconscious person. **If in eyes:** Hold eye open and rinse slowly and gently with water for 15-20 minutes. Remove contact lenses, if present, after the first 5 minutes, then continue rinsing eye. Call a poison control center or doctor for treatment advice. **If inhaled:** Move person to fresh air. If person is not breathing call 911 or an ambulance, then give artificial respiration, preferably mouth-to-mouth if possible. Call a poison control center or doctor for further treatment advice.

NOTE TO PHYSICIAN: Contains petroleum distillate – vomiting may cause aspiration pneumonia.

Have the product container or label with you when calling a poison control center or doctor, or going for treatment.

HOT LINE NUMBER: For 24-Hour Medical Emergency Assistance (Human or Animal) or Chemical Emergency Assistance (Spill, Leak, Fire, or Accident) Call **1-800-888-8372**.

Environmental Hazards: This product is toxic to fish. Do not apply directly to water, or to areas where surface water is present, or to intertidal areas below the mean high water mark. Do not contaminate water when disposing of equipment washwater or rinsate. Do not apply when weather conditions favor drift from target area.

Ground Water Advisory: Fluazifop-P-butyl is known to leach through soil into ground water under certain conditions as a result of label use.

This chemical may leach into ground water if used in areas where soils are permeable, particularly where the water table is shallow.

This product may impact surface water quality due to runoff of rain water. This is especially true for poorly draining soils and soils with shallow ground water.

This product is classified as having high potential for reaching surface water via runoff for several months or more after application. A level, well-maintained vegetative buffer strip between areas to which this product is applied and surface water features such as ponds, streams, and springs will reduce the potential loading of fluazifop-p-butyl from runoff water and sediment. Runoff of this product will be reduced by avoiding applications when rainfall is forecasted to occur within 48 hours.

Physical and Chemical Hazards: Combustible. Do not use or store near heat or open flame.

Chemigation: Do not apply Fusion Herbicide through any type of irrigation system.

STORAGE AND DISPOSAL

Do not contaminate water, food or feed by storage and disposal.

Pesticide Storage: Store in original container only. Keep container closed when not in use. Do not store near food or feed. In case of spill or leak on floor or paved surfaces, soak up with sand, earth or synthetic absorbent. Remove to chemical waste area.

Pesticide Disposal: Open dumping is prohibited. Pesticide wastes are toxic. Improper disposal of excess pesticide, spray mixture or rinsate is a violation of federal law. If these wastes cannot be disposed of by use according to label instructions, contact your State Pesticide or Environmental Control Agency or the Hazardous Waste Representative at the nearest EPA Regional Office for guidance.

Container Handling [less than 5 gallons]: Non-refillable container. Do not reuse or refill this container. Offer for recycling if available. Triple-rinse container (or equivalent) promptly after emptying. Triple rinse as follows: Empty the remaining contents into application equipment or a mix tank and drain for 10 seconds after the flow begins to drip. Fill the container 1/4 full with water and recap. Shake for 10 seconds. Pour rinsate into application equipment or a mix tank or store rinsate for later use and disposal. Drain for 10 seconds after the flow begins to drip. Repeat this procedure two more times. Then offer for recycling if available or puncture and dispose of in a sanitary landfill, by incineration or, if allowed by state and local authorities, by burning. If burned, stay out of smoke.



BAR CODE # IS
(01) 0 07 02941 73290
LAST DIGIT IS CHECK DIGIT
UCC/EAN 128

FUSION®

Date: 6/17/2015
 Replaces: 2/23/2015

1. PRODUCT IDENTIFICATION

Product identifier on label: **FUSION®**
 Product No.: A12869A
 Use: Herbicide
 Manufacturer: Syngenta Crop Protection, LLC
 Post Office Box 18300
 Greensboro NC 27419
 Manufacturer Phone: 1-800-334-9481

Emergency Phone: 1-800-888-8372

2. HAZARDS IDENTIFICATION

Classifications: Skin Corrosion/Irritation: Category 2
 Skin Sensitizer: Category 1B
 Reproductive Toxicity: Category 2
 Specific Target Organ Toxicity: Repeated Category 2
 Specific Target Organ Toxicity: Drowsiness Category 3
 Specific Target Organ Toxicity: Respiratory Irritation Category 3
 Aspiration Hazard: Category 1
 Flammable Liquid: Category 4
 Eye Damage/Irritation: Category 2B
 Carcinogenicity: Category 1B

Signal Word (OSHA): Danger

Hazard Statements: Combustible liquid
 May be fatal if swallowed and enters airways
 Causes skin irritation
 May cause an allergic skin reaction
 Causes eye irritation
 May cause respiratory irritation
 May cause drowsiness or dizziness
 May cause cancer
 Suspected of damaging fertility or the unborn child
 May cause damage to organs through prolonged or repeated exposure

Hazard Symbols:



FUSION®

Date: 6/17/2015
Replaces: 2/23/2015

Precautionary Statements:

- Contaminated work clothing must not be allowed out of the workplace.
- If in eyes: Rinse cautiously with water for several minutes. Remove contact lenses, if present and easy to do. Continue rinsing.
- If eye irritation persists: Get medical advice.
- Obtain special instructions before use.
- Do not handle until all safety precautions have been read and understood.
- Keep away from heat, sparks, open flames, hot surfaces. No smoking.
- Do not breathe mist, vapors, spray.
- Wash hands and face thoroughly after handling.
- Use only outdoors or in a well-ventilated area.
- Wear protective gloves, protective clothing, eye protection.
- If swallowed: Immediately call a poison center, doctor or Syngenta.
- If on skin: Wash with plenty of soap and water.
- If skin irritation or rash occurs: Get medical advice.
- If inhaled: Remove person to fresh air and keep comfortable for breathing.
- If exposed or concerned: Get medical advice/attention.
- Call a poison center, doctor or Syngenta if you feel unwell.
- See Section 4 First Aid Measures.
- Do NOT induce vomiting.
- Take off contaminated clothing and wash it before reuse.
- In case of fire: Use dry chemical, foam or CO2 for extinction.
- Store in a well-ventilated place. Keep cool.
- Store locked up.
- Dispose of contents and container in accordance with local regulations.

Other Hazard Statements: None

3. COMPOSITION/INFORMATION ON INGREDIENTS

Chemical Name	Common Name	CAS Number	Concentration
Xylene	Xylene	1330-20-7	<5.0%
1,2,4-Trimethylbenzene	1,2,4-Trimethylbenzene	95-63-6	<5.0%
Naphthalene	Naphthalene	91-20-3	<10.0%
Petroleum Solvent	Petroleum Solvent	Trade Secret	Trade Secret
Other ingredients	Other ingredients	Trade Secret	<49.09%
Butyl(RS)-2-[4-[[5-(trifluoromethyl)-2-pyridinyl]oxy]phenoxy]propanoate	Fluazifop-P-Butyl	79241-46-6	24.15%
(D+)-ethyl 2-(4-(6-chloro-2-benzoxazolyl)oxy)-phenoxy)propanoate	Fenoxaprop-P-Ethyl	71283-80-2	6.76%

Ingredients not precisely identified are proprietary or non-hazardous. Values are not product specifications.

FUSION®

Date: 6/17/2015

Replaces: 2/23/2015

4. FIRST AID MEASURES

Have the product container, label or Safety Data Sheet with you when calling Syngenta (800-888-8372), a poison control center or doctor, or going for treatment.

- Ingestion:** If swallowed: Call Syngenta (800-888-8372), a poison control center or doctor immediately for treatment advice. Do not give any liquid to the person. Do not induce vomiting unless told to do so after calling 800-888-8372 or by a poison control center or doctor. Do not give anything by mouth to an unconscious person.
- Eye Contact:** If in eyes: Hold eye open and rinse slowly and gently with water for 15-20 minutes. Remove contact lenses, if present, after 5 minutes, then continue rinsing eye. Call Syngenta (800-888-8372), a poison control center or doctor for treatment advice.
- Skin Contact:** If on skin or clothing: Take off contaminated clothing. Rinse skin immediately with plenty of water for 15-20 minutes. Call Syngenta (800-888-8372), a poison control center or doctor for treatment advice.
- Inhalation:** If inhaled: Move person to fresh air. If person is not breathing, call 911 or an ambulance, then give artificial respiration, preferably mouth-to-mouth if possible. Call Syngenta (800-888-8372), a poison control center or doctor for further treatment advice.

Most important symptoms/effects:

- Eye irritation
- Skin irritation
- Drowsiness or dizziness
- Respiratory irritation

Indication of immediate medical attention and special treatment needed:

- There is no specific antidote if this product is ingested.
- Treat symptomatically.
- Contains petroleum distillate - vomiting may cause aspiration pneumonia.

5. FIRE FIGHTING MEASURES

Suitable (and unsuitable) extinguishing media:

Use dry chemical, foam or CO2 extinguishing media. If water is used to fight fire, dike and collect runoff.

Specific Hazards:

Combustible liquid. Can release vapors that form explosive mixtures at temperatures at or above the flash point. Heavy vapors can flow along surfaces to distant ignition sources and flash back.

During a fire, irritating and possibly toxic gases may be generated by thermal decomposition or combustion.

Special protective equipment and precautions for firefighters:

Wear full protective clothing and self-contained breathing apparatus. Evacuate nonessential personnel from the area to prevent human exposure to fire, smoke, fumes or products of combustion.

6. ACCIDENTAL RELEASE MEASURES

Personal precautions, protective equipment, and emergency procedures:

Follow exposure controls/personal protection outlined in Section 8.

Methods and materials for containment and cleaning up:

Control the spill at its source. Contain the spill to prevent from spreading or contaminating soil or from entering sewage and drainage systems or any body of water. Clean up spills immediately, observing precautions outlined in Section 8. Cover entire spill with absorbing material and place into compatible disposal container. Scrub area with hard water detergent (e.g. commercial products such as Tide, Joy, Spic and Span). Pick up wash liquid with additional absorbent and place into compatible disposal container. Once all material is cleaned up and placed in a disposal container, seal container and

FUSION®

Date: 6/17/2015
Replaces: 2/23/2015

arrange for disposition.

7. HANDLING AND STORAGE

Precautions for safe handling:

Store the material in a well-ventilated, secure area out of reach of children and domestic animals. Do not store food, beverages or tobacco products in the storage area. Prevent eating, drinking, tobacco use, and cosmetic application in areas where there is a potential for exposure to the material. Wash thoroughly with soap and water after handling.

Conditions for safe storage, including any incompatibilities:

Store locked up.

8. EXPOSURE CONTROLS/PERSONAL PROTECTION

THE FOLLOWING RECOMMENDATIONS FOR EXPOSURE CONTROLS/PERSONAL PROTECTION ARE INTENDED FOR THE MANUFACTURE, FORMULATION AND PACKAGING OF THIS PRODUCT.

FOR COMMERCIAL APPLICATIONS AND/OR ON-FARM APPLICATIONS CONSULT THE PRODUCT LABEL.

Occupational Exposure Limits:

Chemical Name	OSHA PEL	ACGIH TLV	Other	Source
Xylene	100 ppm TWA	100 ppm TWA; 150 ppm STEL	100 ppm TWA	NIOSH
1,2,4-Trimethylbenzene	Not Established	25 ppm TWA	25 ppm TWA	NIOSH
Naphthalene	10 ppm TWA	10 ppm TWA (skin)	10 ppm TWA	NIOSH
Petroleum Solvent	Not Established	Not Established	50 mg/m ³ (8 ppm) TWA	Manufacturer
Other ingredients	Not Applicable	Not Applicable	Not Applicable	Not Applicable
Fluazifop-P-Butyl	Not Established	Not Established	0.5 mg/m ³ TWA	Syngenta
Fenoxaprop-P-Ethyl	Not Established	Not Established	0.1 mg/m ³ TWA	Manufacturer

Appropriate engineering controls:

Use effective engineering controls to comply with occupational exposure limits (if applicable).

Individual protection measures:

Ingestion:

Prevent eating, drinking, tobacco usage and cosmetic application in areas where there is a potential for exposure to the material. Wash thoroughly with soap and water after handling.

Eye Contact:

Where eye contact is likely, use chemical splash goggles. Facilities storing or utilizing this material should be equipped with an eyewash facility and a safety shower.

Skin Contact:

Where contact is likely, wear chemical-resistant gloves (such as barrier laminate or Viton), coveralls, socks and chemical-resistant footwear.

Inhalation:

A combination particulate/organic vapor respirator should be used until effective engineering controls are installed to comply with occupational exposure limits, or until exposure limits are established. Use a NIOSH certified respirator with an organic vapor (OV) cartridge or canister with any R, P or HE filter.

FUSION®

Date: 6/17/2015
Replaces: 2/23/2015

Use a self-contained breathing apparatus in cases of emergency spills, when exposure levels are unknown, or under any circumstances where air-purifying respirators may not provide adequate protection.

9. PHYSICAL AND CHEMICAL PROPERTIES

Appearance: Uniform dark brown liquid, insoluble material free
Odor: Aromatic
Odor Threshold: Not Available
pH: 5.8 (1% w/w dilution in deionized water)
Melting point/freezing point: Not Applicable
Initial boiling point and boiling range: Not Available
Flash Point (Test Method): 149°F (method not available)
Flammable Limits (% in Air): Not Available
Flammability: Combustible liquid
Vapor Pressure: Fenoxaprop-P-Ethyl 1.4 x 10⁽⁻⁶⁾ mmHg @ 68°F (20°C)
Fluazifop-P-Butyl 4.5 x 10⁽⁻⁷⁾ mmHg @ 68°F (20°C)
Vapor Density: Not Available
Relative Density: 0.9983 g/ml
Solubility (ies): Fenoxaprop-P-Ethyl 0.7 - 0.8 mg/l @ 77°F (25°C)
Fluazifop-P-Butyl Almost insoluble in water (1 mg/l @ pH 5 - 6.5)
Partition coefficient: n-octanol/water: Not Available
Autoignition Temperature: Not Available
Decomposition Temperature: Not Available
Viscosity: Not Available
Other: None

10. STABILITY AND REACTIVITY

Reactivity: Not reactive.
Chemical stability: Stable under normal use and storage conditions.
Possibility of hazardous reactions: Will not occur.
Conditions to Avoid: None known.
Incompatible materials: None known.
Hazardous Decomposition Products: None known.

11. TOXICOLOGICAL INFORMATIONHealth effects information

Likely routes of exposure: Dermal, Inhalation

Symptoms of exposure: Eye irritation, Drowsiness or dizziness, Skin irritation, Respiratory irritation

Delayed, immediate and chronic effects of exposure: Possible carcinogenicity, Eye irritation, Skin irritation, Allergic skin

FUSION®

Date: 6/17/2015
Replaces: 2/23/2015

reaction, Drowsiness or dizziness, Respiratory irritation

Numerical measures of toxicity (acute toxicity/irritation studies (finished product))

Ingestion: Oral (LD50 Rabbit) : 3154 mg/kg body weight
 Dermal: Dermal (LD50 Rabbit) : > 2000 mg/kg body weight
 Inhalation: Inhalation (LC50 Rat) : > 5.02 mg/l air - 4 hours
 Eye Contact: Moderately Irritating (Rabbit)
 Skin Contact: Moderately Irritating (Rabbit)
 Skin Sensitization: Likely to be a skin sensitizer based on active ingredient(s).

Reproductive/Developmental Effects

Fenoxaprop-P-Ethyl : In developmental studies, effects were seen in the mother and the pups in the high dose groups. The manufacturer does not consider these results as being significant. However, the compound has been reviewed by the European Food Safety Authority (EFSA), and the classification "Toxic to reproduction", category 3 (R63) has been proposed to the European Chemicals Agency (ECHA).

Fluazifop-P-Butyl : Embryo/foetoxic effects have been reported in rats. Did not show teratogenic effects in animal experiments.

Chronic/Subchronic Toxicity Studies

Fenoxaprop-P-Ethyl : Not Available

Fluazifop-P-Butyl : Effects on red cells, bone marrow, liver and spleen observed in long-term high dose feeding tests in dogs. No adverse health effects are expected in humans at airborne levels below the occupational exposure limit.

Carcinogenicity

Fenoxaprop-P-Ethyl : In vitro and in vivo mutagenicity tests to not indicate genotoxic activity. Did not show carcinogenic effects in animal experiments.

Fluazifop-P-Butyl : Did not show mutagenic effects in animal experiments. Did not show carcinogenic effects in animal experiments.

Chemical Name	NTP/IARC/OSHA Carcinogen
Xylene	IARC Group 3
1,2,4-Trimethylbenzene	No
Naphthalene	See "Toxicity", Sec. 11
Petroleum Solvent	No
Other ingredients	No
Butyl(RS)-2-[4-[[5-(trifluoromethyl)-2-pyridinyl]oxy]phenoxy]propanoate	No
(D+)-ethyl 2-(4-(6-chloro-2-benzoxazolyloxy)-phenoxy)propanoate	No

Other Toxicity Information

None

Toxicity of Other Components

1,2,4-Trimethylbenzene

Inhalation of 1,2,4-trimethylbenzene at high concentrations can cause central nervous system depression, respiratory tract irritation, asphyxiation, cardiac stress and coma. Effects of chronic exposure to this solvent can include blood disorders (anemia, leukopenia) and kidney or liver damage.

FUSION®

Date: 6/17/2015
Replaces: 2/23/2015

Naphthalene

Exposure to naphthalene can cause cataracts, liver damage, kidney failure, respiratory failure, hematuria, anemia, damage to red blood cells, leukocytosis, or coma.

Carcinogen Status:

NTP: Anticipated Carcinogen

IARC: Group 2B Possible Human Carcinogen

Other ingredients

Not Applicable

Petroleum Solvent

Repeated exposure may cause skin dryness or cracking. If swallowed, may be aspirated and cause lung damage. May be irritating to the eyes, nose, throat and lungs.

Breathing of high vapor concentrations may cause central nervous system (CNS) depression resulting in dizziness, light-headedness, headache, nausea and loss of coordination.

Xylene

Inhalation of xylene at high concentrations can cause central nervous system depression, respiratory tract irritation, asphyxiation, cardiac stress and coma.

Target Organs

Active Ingredients

Fenoxaprop-P-Ethyl :	Liver, eye
Fluazifop-P-Butyl :	Blood, bone marrow, liver, spleen

Inert Ingredients

1,2,4-Trimethylbenzene:	CNS, liver, kidney, blood, respiratory tract, skin, eye
Naphthalene:	Eye, liver, kidney, respiratory tract, blood, CNS
Other ingredients:	Not Applicable
Petroleum Solvent:	Respiratory tract, stomach, liver, thyroid, urinary bladder, CNS, skin
Xylene:	CNS, respiratory tract, skin

12. ECOLOGICAL INFORMATION

Eco-Acute Toxicity

Fluazifop-P-Butyl :

- Invertebrate (Water Flea) Daphnia Magna 48-hour EC50 6.02 ppm
- Green Algae 4-day EC50 > 1.8 ppm
- Bird (Mallard Duck) 14-day LD50 > 3528 mg/kg

Fenoxaprop-P-Ethyl :

- Fish (Bluegill Sunfish) 96-hour LC50 0.31 - 0.58 mg/l
- Invertebrate (Water Flea) Daphnia Magna 48-hour EC50 > 1.058 mg/l
- Bird (Bobwhite Quail) LD50 > 2000 mg/kg

Environmental Fate

Fenoxaprop-P-Ethyl :

The information presented here is for the active ingredient, fenoxaprop-p-ethyl. Slightly soluble in water, absorbs strongly to soils, and has low mobility.

FUSION®

Date: 6/17/2015

Replaces: 2/23/2015

Fluazifop-P-Butyl :

The information presented here is for the active ingredient, fluazifop-p-butyl.
Not persistent in soil or water.

13. DISPOSAL CONSIDERATIONS

Disposal:

Do not reuse product containers. Dispose of product containers, waste containers, and residues according to local, state, and federal health and environmental regulations.

Characteristic Waste: Not Applicable

Listed Waste: Not Applicable

14. TRANSPORT INFORMATION

DOT Classification

Ground Transport - NAFTA

< 119 gal: Not regulated

> 119 gal:

Proper Shipping Name: Combustible Liquid, N.O.S. (Naphthalene, Petroleum Solvent)

Hazard Class: Combustible Liquid

Identification Number: NA 1993

Packing Group: PG III

Comments

Water Transport - International

Proper Shipping Name: Environmentally Hazardous Substance, Liquid, N.O.S. (Fluazifop-P-Butyl, Fenoxaprop-P-Ethyl), Marine Pollutant

Hazard Class: Class 9

Identification Number: UN 3082

Packing Group: PG III

Air Transport - International

Proper Shipping Name: Environmentally Hazardous Substance, Liquid, N.O.S. (Fluazifop-P-Butyl, Fenoxaprop-P-Ethyl)

Hazard Class: Class 9

Identification Number: UN 3082

Packing Group: PG III

Note: This product is currently not regulated for airfreight within the NAFTA region. However, effective 01/01/2011 the above classification must be used.

15. REGULATORY INFORMATION

Pesticide Registration:

This chemical is a pesticide product registered by the Environmental Protection Agency and is subject to certain labeling requirements under federal pesticide law. These requirements differ from the classification criteria and hazard information required for safety data sheets, and for workplace labels of non-pesticide chemicals. Following is the hazard information as required on the pesticide label:

Warning: WARNING. Causes skin irritation. Harmful if absorbed through skin or swallowed. Causes moderate eye irritation. Do not get on skin or on clothing. Avoid contact with eyes. Avoid breathing spray mist. Prolonged or frequently repeated skin contact may cause allergic reactions in some individuals.

EPA Registration Number(s):

100-1059

FUSION®

Date: 6/17/2015
 Replaces: 2/23/2015

EPCRA SARA Title III Classification:

Section 311/312 Hazard Classes: Acute Health Hazard
 Chronic Health Hazard
 Fire Hazard

Section 313 Toxic Chemicals: Xylene <5.0% (CAS No. 1330-20-7)
 1,2,4-Trimethylbenzene <5.0% (CAS No. 95-63-6)
 Naphthalene <10.0% (CAS No. 91-20-3)

CERCLA/SARA 304 Reportable Quantity (RQ):

>1,300 lbs (based on naphthalene, CAS # 91-20-3 [RQ = 100 lbs] in the formulation)

RCRA Hazardous Waste Classification (40 CFR 261):

Not Applicable

TSCA Status:

Exempt from TSCA, subject to FIFRA

16. OTHER INFORMATION

NFPA Hazard Ratings

Health: 2
 Flammability: 2
 Instability: 0

HMIS Hazard Ratings

Health: 2
 Flammability: 2
 Reactivity: 0

0	Minimal
1	Slight
2	Moderate
3	Serious
4	Extreme
*	Chronic

Syngenta Hazard Category: D,S

For non-emergency questions about this product call:

1-800-334-9481

Original Issued Date: 10/19/1998

Revision Date: 6/17/2015

Replaces: 2/23/2015

Section(s) Revised: 2

The information and recommendations contained herein are based upon data believed to be correct. However, no guarantee or warranty of any kind, expressed or implied, is made with respect to the information contained herein.

Specimen Label



Dow AgroSciences



SPECIALTY HERBICIDE

®Trademark of The Dow Chemical Company ("Dow") or an affiliated company of Dow

For the control of woody plants, broadleaf weeds in range and pasture, forests and non-crop areas, including manufacturing and storage sites, rights-of-way such as electrical power lines, communication lines, pipelines, roadsides, railroads, fence rows, non-irrigation ditch banks, and around farm buildings; and applications to grazed areas, and establishment and maintenance of wildlife openings, and in Christmas tree plantations and aquatic sites.

For use in New York State, comply with Section 24(c) Special Local Need labeling for Garlon 3A, SLN NY-110005.

GROUP	4	HERBICIDE
-------	---	-----------

Active Ingredient:

Triclopyr: 2-[(3,5,6-trichloro-2-pyridinyl)oxy] acetic acid, triethylamine salt.....	44.4%
Other Ingredients.....	55.6%
Total.....	100.0%

Acid equivalent: triclopyr - 31.8% - 3 lb/gal

Precautionary Statements

Hazard to Humans and Domestic Animals

EPA Reg. No. 62719-37

DANGER

Corrosive • Causes Irreversible Eye Damage • Harmful If Swallowed Or Absorbed Through Skin • Prolonged Or Frequently Repeated Skin Contact May Cause Allergic Reaction In Some Individuals

Do not get in eyes, on skin, or on clothing. Wash thoroughly after handling and before eating, drinking, chewing gum, using tobacco, or using the toilet. Remove and wash contaminated clothing before reuse.

Personal Protective Equipment (PPE)

Applicators and other handlers must wear:

- Long-sleeved shirt and long pants
- Shoes plus socks
- Protective eyewear
- Chemical resistant gloves (≥14 mils) such as butyl rubber, natural rubber, neoprene rubber or nitrile rubber

Discard clothing and other absorbent materials that have been drenched or heavily contaminated with this product's concentrate. Do not reuse them. Follow manufacturer's instructions for cleaning/maintaining PPE. If no such instructions for washables exist, use detergent and hot water. Keep and wash PPE separately from other laundry.

Engineering Controls

When handlers use closed systems, enclosed cabs, or aircraft in a manner that meets the requirements listed in the Worker Protection Standard (WPS) for agricultural pesticides (40 CFR 170.240(d)(4-6)), the handler PPE requirements may be reduced or modified as specified in the WPS.

User Safety Recommendations

Users should:

- Remove clothing/PPE immediately if pesticide gets inside. Then wash thoroughly and put on clean clothing.
- Remove PPE immediately after handling this product. Wash the outside of gloves before removing. As soon as possible, wash thoroughly and change into clean clothing.

First Aid

If in eyes: Hold eye open and rinse slowly and gently with water for 15-20 minutes. Remove contact lenses, if present, after the first 5 minutes, then continue rinsing eye. Call a poison control center or doctor for treatment advice.

If on skin or clothing: Take off contaminated clothing. Rinse skin immediately with plenty of water for 15-20 minutes. Call a poison control center or doctor for treatment advice.

If swallowed: Call a poison control center or doctor immediately for treatment advice. Have person sip a glass of water if able to swallow. Do not induce vomiting unless told to do so by a poison control center or doctor. Do not give anything by mouth to an unconscious person. Have the product container or label with you when calling a poison control center or doctor, or going for treatment. You may also contact 1-800-992-5994 for emergency medical treatment information.

Note to Applicator: Allergic skin reaction is not expected from exposure to spray mixtures of Garlon 3A herbicide when used as directed.

Note to Physician: Probable mucosal damage may contraindicate the use of gastric lavage.

Environmental Hazards

Do not contaminate water when cleaning equipment or disposing of equipment washwaters. Under certain conditions, treatment of aquatic weeds can result in oxygen depletion or loss due to decomposition of dead plants, which may contribute to fish suffocation. This loss can cause fish suffocation. Therefore, to minimize this hazard, do not treat more than one-third to one-half of the water area in a single operation and wait at least 10 to 14 days between treatments. Begin treatment along the shore and proceed outwards in bands to allow fish to move into untreated areas. Consult with the State agency for fish and game before applying to public water to determine if a permit is needed.

This chemical has properties and characteristics associated with chemicals detected in groundwater. The use of this chemical in areas where soils are permeable, particularly where the water table is shallow, may result in groundwater contamination.

Physical or Chemical Hazards

Combustible. Do not use or store the product near heat or open flame.

Directions for Use

It is a violation of Federal law to use this product in a manner inconsistent with its labeling.

Read all Directions for Use carefully before applying.

Do not apply this product in a way that will contact workers or other persons, either directly or through drift. Only protected handlers may be in the area during application. For any requirements specific to your state or tribe, consult the agency responsible for pesticide regulation

Agricultural Use Requirements

Use this product only in accordance with its labeling and with the Worker Protection Standard, 40 CFR Part 170. This Standard contains requirements for the protection of agricultural workers on farms, forests, nurseries, and greenhouses, and handlers of agricultural pesticides. It contains requirements for training, decontamination, notification, and emergency assistance. It also contains specific instructions and exceptions pertaining to the statements on this label about personal protective equipment (PPE), and restricted-entry interval. The requirements in this box only apply to uses of this product that are covered by the Worker Protection Standard.

Do not enter or allow worker entry into treated areas during the restricted entry interval (REI) of 48 hours.

PPE required for early entry to treated areas that is permitted under the Worker Protection Standard and that involves contact with anything that has been treated, such as plants, soil, or water, is:

- Coveralls
- Shoes plus socks
- Protective eyewear
- Chemical-resistant gloves (≥14 mils) such as butyl rubber, natural rubber, neoprene rubber or nitrile rubber

Non-Agricultural Use Requirements

The requirements in this box apply to uses of this product that are NOT within the scope of the Worker Protection Standard for Agricultural Pesticides (40 CFR Part 170). The WPS applies when this product is used to produce agricultural plants on farms, forests, nurseries, or greenhouses.

Entry Restrictions for Non-WPS Uses: For applications to non-cropland areas, do not allow entry into areas until sprays have dried, unless applicator and other handler PPE is worn.

Storage and Disposal

Do not contaminate water, food, or feed by storage and disposal. Open dumping is prohibited.

Pesticide Storage: Store above 28°F or agitate before use.

Pesticide Disposal: Wastes resulting from the use of this product must be disposed of on site or at an approved waste disposal facility.

Nonrefillable containers 5 gallons or less:

Container Handling: Nonrefillable container. Do not reuse or refill this container. Offer for recycling if available or puncture and dispose of in a sanitary landfill, or by incineration, or by other procedures allowed by state and local authorities.

Triple rinse or pressure rinse container (or equivalent) promptly after emptying. **Triple rinse** as follows: Empty the remaining contents into application equipment or a mix tank and drain for 10 seconds after the flow begins to drip. Fill the container 1/4 full with water and recap. Shake for 10 seconds. Pour rinsate into application equipment or a mix tank or store rinsate for later use or disposal. Drain for 10 seconds after the flow begins to drip. Repeat this procedure two more times. **Pressure rinse** as follows: Empty the remaining contents into application equipment or a mix tank and continue to drain for 10 seconds after the flow begins to drip. Hold container upside down over application equipment or mix tank or collect rinsate for later use or disposal. Insert pressure rinsing nozzle in the side of the container, and rinse at about 40 psi for at least 30 seconds. Drain for 10 seconds after the flow begins to drip.

Refillable containers 5 gallons or larger:

Container Handling: Refillable container. Refill this container with pesticide only. Do not reuse this container for any other purpose. Cleaning the container before final disposal is the responsibility of the person disposing of the container. Cleaning before refilling is the responsibility of the refiller. To clean the container before final disposal, empty the remaining contents from this container into application equipment or a mix tank. Fill the container about 10% full with water. Agitate vigorously or recirculate water with the pump for two minutes. Pour or pump rinsate into application equipment or rinsate collection system. Repeat this rinsing procedure two more times.

Nonrefillable containers 5 gallons or larger:

Container Handling: Nonrefillable container. Do not reuse or refill this container. Offer for recycling if available or puncture and dispose of in a sanitary landfill, or by incineration, or by other procedures allowed by state and local authorities.

Triple rinse or pressure rinse container (or equivalent) promptly after emptying. **Triple rinse** as follows: Empty the remaining contents into application equipment or a mix tank. Fill the container 1/4 full with water. Replace and tighten closures. Tip container on its side and roll it back and forth, ensuring at least one complete revolution, for 30 seconds. Stand the container on its end and tip it back and forth several times. Turn the container over onto its other end and tip it back and forth several times. Empty the rinsate into application equipment or a mix tank or store rinsate for later use or disposal. Repeat this procedure two more times. **Pressure rinse** as follows: Empty the remaining contents into application equipment or a mix tank and continue to drain for 10 seconds after the flow begins to drip. Hold container upside down over application equipment or mix tank or collect rinsate for later use or disposal. Insert pressure rinsing nozzle in the side of the container, and rinse at about 40 psi for at least 30 seconds. Drain for 10 seconds after the flow begins to drip.

Product Information

Use Garlon® 3A specialty herbicide for the control of woody plants and broadleaf weeds in range and pasture, forests and non-crop areas including manufacturing and storage sites, rights-of-way such as electrical power lines, communication lines, pipelines, roadsides, railroads, fence rows, non-irrigation ditch banks, and around farm buildings, and applications to grazed areas, and establishment and maintenance of wildlife openings, and in Christmas tree plantations and aquatic sites.

Obtain Required Permits: Consult with appropriate state or local water authorities before applying this product to public waters. State or local public agencies may require permits.

Use Precautions

It is permissible to treat non-irrigation ditch banks, seasonally dry wetlands (such as flood plains, deltas, marshes, swamps, or bogs), and transitional areas between upland and lowland sites.

When making applications to control unwanted plants on banks or shorelines of moving water sites, minimize overspray to open water.

Use Restrictions

For use in New York State, comply with Section 24(c) Special Local Need labeling for Garlon 3A, SLN NY-110005.

Chemigation: Do not apply this product through any type of irrigation system.

Do not apply Garlon 3A directly to, or otherwise permit it to come into direct contact with, grapes, tobacco, vegetable crops, flowers, or other desirable broadleaf plants. Do not permit spray mists containing Garlon 3A to drift onto such plants.

Do not apply to salt water bays or estuaries.

Do not apply directly to un-impounded rivers or streams.

Do not apply on ditches or canals currently being used to transport irrigation water or that will be used for irrigation within 4 months following treatment. It is permissible to treat irrigation and non-irrigation ditch banks.

Do not apply where runoff water may flow onto agricultural land as injury to crops may result.

Do not apply with a mistblower.

Water treated with Garlon 3A may not be used for irrigation purposes for 120 days after application or until residue levels of Garlon 3A are determined by laboratory analysis, or other appropriate means of analysis, to be 1 ppb or less.

Seasonal Irrigation Waters: Garlon 3A may be applied during the off-season to surface waters that are used for irrigation on a seasonable basis provided that there is a minimum of 120 days between applying Garlon 3A and the first use of treated water for irrigation purposes, or until residue levels of Garlon 3A are determined by laboratory analysis, or other appropriate means of analysis, to be 1 ppb or less.

Irrigation Canals/Ditches: Do not apply Garlon 3A to irrigation canals/ditches unless the 120-day restriction on irrigation water usage can be observed or residue levels of Garlon 3A are determined by laboratory analysis, or other appropriate means of analysis, to be 1 ppb or less.

Maximum Use Rates

- Apply no more than 6 lb ae of triclopyr (2 gallons of Garlon 3A) per acre per year on aquatic sites.
- Apply no more than 2 lb ae of triclopyr (2/3 gallon of Garlon 3A) per acre per growing season on range and pasture sites, including rights-of-way, fence rows or any area where grazing or harvesting of hay is allowed.
- On forestry sites, Garlon 3A may be used at rates up to 6 lb ae of triclopyr (2 gallons of Garlon 3A) per acre per year.
- For all terrestrial use sites other than range, pasture, forestry sites, and grazed/hayed areas, the maximum application rate is 9 lb ae of triclopyr (3 gallons of Garlon 3A) per acre per year.

Precautions for Potable Water Intakes for Emerged Aquatic Weed Control

See chart below for specific setback distances near functioning potable water intakes. **Note:** Existing potable water intakes which are no longer in use, such as those replaced by potable water wells or connections to a municipal water system, are not considered to be functioning potable water intakes. These setback restrictions do not apply to terrestrial applications made adjacent to potable water intakes.

Area Treated (acres)	Garlon 3A Application Rate			
	2 qt/acre	4 qt/acre	6 qt/acre	8 qt/acre
4	0	200	400	500
>4 - 8	0	200	700	900
>8 - 16	0	200	700	1000
>16	0	200	900	1300

To apply Garlon 3A around and within the distances noted above from a functioning potable water intake, the intake must be turned off until the triclopyr level in the intake water is determined to be 0.4 parts per million (ppm) or less by laboratory analysis or immunoassay.

Recreational Use of Water in Treatment Area: There are no restrictions on use of water in the treatment area for recreational purposes, including swimming and fishing.

Livestock Use of Water from Treatment Area: There are no restrictions on livestock consumption of water from the treatment area.

Grazing and Haying Restrictions

Grazing green forage:

- There are no grazing restrictions for livestock or dairy animals on treated areas.

Haying (harvesting of dried forage)

- Do not harvest hay for 14 days after application.

Slaughter Restrictions: During the season of application, withdraw livestock from grazing treated grass at least 3 days before slaughter.

Avoiding Injurious Spray Drift

Make applications only when there is little or no hazard from spray drift. Small quantities of spray, which may not be visible, may seriously injure susceptible plants. Do not spray when wind is blowing toward susceptible crops or ornamental plants that are near enough to be injured. It is suggested that a continuous smoke column at or near the spray site or a smoke generator on the spray equipment be used to detect air movement, lapse conditions, or temperature inversions (stable air). If the smoke layers or indicates a potential of hazardous spray drift, do not spray.

Aerial Application: For aerial application on rights-of-way or other areas near susceptible crops, apply through a Microfoil[†] or Thru-Valve boom[†], or use an agriculturally labeled drift control additive. Other drift reducing systems or thickened sprays prepared by using high viscosity inverting systems may be used if they are made as drift-free as mixtures containing agriculturally labeled thickening agents or applications made with the Microfoil or Thru-Valve boom. Keep spray pressures low enough to provide coarse spray droplets. Spray boom should be no longer than 3/4 of the rotor length. Do not use a thickening agent with the Microfoil or Thru-Valve booms, or other systems that cannot accommodate thick sprays. Spray only when the wind velocity is low (follow state regulations). Avoid application during air inversions. If a spray thickening agent is used, follow all use recommendations and precautions on the product label.

[†]Reference within this label to a particular piece of equipment produced by or available from other parties is provided without consideration for use by the reader at its discretion and subject to the reader's independent circumstances, evaluation, and expertise. Such reference by Dow AgroSciences is not intended as an endorsement of such equipment, shall not constitute a warranty (express or implied) of such equipment, and is not intended to imply that other equipment is not available and equally suitable. Any discussion of methods of use of such equipment does not imply that the reader should use the equipment other than is advised in directions available from the equipment's manufacturer. The reader is responsible for exercising its own judgment and expertise, or consulting with sources other than Dow AgroSciences, in selecting and determining how to use its equipment.

Spray Drift Management

Avoiding spray drift at the application site is the responsibility of the applicator. The interaction of many equipment and weather related factors determine the potential for spray drift. The applicator and the grower are responsible for considering all these factors when making decisions.

The following drift management requirements must be followed to avoid off-target drift movement from aerial applications:

1. The distance of the outer most operating nozzles on the boom must not exceed 3/4 the length of the rotor.
2. Nozzles must always point backward parallel with the air stream and never be pointed downwards more than 45 degrees.

Where states have more stringent regulations, they must be observed.

The applicator should be familiar with and take into account the information covered in the following Aerial Drift Reduction Advisory. [This information is advisory in nature and does not supersede mandatory label requirements.]

Aerial Drift Reduction Advisory

Information on Droplet Size: The most effective way to reduce drift potential is to apply large droplets. The best drift management strategy is to apply the largest droplets that provide sufficient coverage and control. Applying larger droplets reduces drift potential, but will not prevent drift if applications are made improperly, or under unfavorable environmental conditions (see Wind, Temperature and Humidity, and Temperature Inversions).

Controlling Droplet Size:

- **Volume** - Use high flow rate nozzles to apply the highest practical spray volume. Nozzles with higher rated flows produce larger droplets.
- **Pressure** - Do not exceed the nozzle manufacturer's recommended pressures. For many nozzle types, lower pressure produces larger droplets. When higher flow rates are needed, use higher flow rate nozzles instead of increasing pressure.

- **Number of Nozzles** - Use the minimum number of nozzles that provide uniform coverage.
- **Nozzle Orientation** - Orienting nozzles so that the spray is released parallel to the airstream produces larger droplets than other orientations and is the recommended practice. Significant deflection from horizontal will reduce droplet size and increase drift potential.
- **Nozzle Type** - Use a nozzle type that is designed for the intended application. With most nozzle types, narrower spray angles produce larger droplets. Consider using low-drift nozzles. Solid stream nozzles oriented straight back produce the largest droplets and the lowest drift.

Boom Length: For some use patterns, reducing the effective boom length to less than 3/4 of the rotor length may further reduce drift without reducing swath width.

Application Height: Applications should not be made at a height greater than 10 feet above the top of the largest plants unless a greater height is required for aircraft safety. Making applications at the lowest height that is safe reduces exposure of droplets to evaporation and wind.

Swath Adjustment: When applications are made with a crosswind, the swath will be displaced downwind. Therefore, on the up and downwind edges of the field, the applicator must compensate for this displacement by adjusting the path of the aircraft upwind. Swath adjustment distance should increase, with increasing drift potential (higher wind, smaller drops, etc.).

Wind: Drift potential is lowest between wind speeds of 2 to 10 mph. However, many factors, including droplet size and equipment type, determine drift potential at any given speed. Application should be avoided below 2 mph due to variable wind direction and high inversion potential.

Note: Local terrain can influence wind patterns. Every applicator should be familiar with local wind patterns and how they affect spray drift.

Temperature and Humidity: When making applications in low relative humidity, set up equipment to produce larger droplets to compensate for evaporation. Droplet evaporation is most severe when conditions are both hot and dry.

Temperature Inversions: Applications should not occur during a local, low level temperature inversion because drift potential is high. Temperature inversions restrict vertical air mixing, which causes small suspended droplets to remain in a concentrated cloud. This cloud can move in unpredictable directions due to the light variable winds common during inversions. Temperature inversions are characterized by increasing temperatures with altitude and are common on nights with limited cloud cover and light to no wind. They begin to form as the sun sets and often continue into the morning. Their presence can be indicated by ground fog; however, if fog is not present, inversions can also be identified by the movement of the smoke from a ground source or an aircraft smoke generator. Smoke that layers and moves laterally in a concentrated cloud (under low wind conditions) indicates an inversion, while smoke that moves upward and rapidly dissipates indicates good vertical air mixing.

Sensitive Areas: The pesticide should only be applied when the potential for drift to adjacent sensitive areas (e.g., residential areas, bodies of water, known habitat for threatened or endangered species, non-target crops) is minimal (e.g., when wind is blowing away from the sensitive areas).

Ground Equipment: To aid in reducing spray drift, Garlon 3A should be used in thickened (high viscosity) spray mixtures using an agriculturally labeled drift control additive, high viscosity invert system, or equivalent as directed by the manufacturer. With ground equipment, spray drift can be reduced by keeping the spray boom as low as possible; by applying 20 gallons or more of spray per acre; by keeping the operating spray pressures at the lower end of the manufacturer's recommended pressures for the specific nozzle type used (low pressure nozzles are available from spray equipment manufacturers); and by spraying when wind velocity is low (follow state regulations). In hand-gun applications, select the minimum spray pressure that will provide adequate plant coverage (without forming a mist). Do not apply with nozzles that produce a fine-droplet spray.

High Volume Leaf-Stem Treatment: To minimize spray drift, do not use pressure exceeding 50 psi at the spray nozzle and keep sprays no higher than brush tops. An agriculturally labeled thickening agent may be used to reduce drift.

Weed Resistance Management:

Triclopyr, the active ingredient in this product, is a Group 4 herbicide based on the mode of action classification system of the Weed Science Society of America. Any weed population may contain or develop plants resistant to Group 4 herbicides. Resistant weeds may dominate the weed population if these herbicides are used repeatedly in the same field. Such resistant weed plants may not be effectively managed using Group 4 herbicides but may be effectively managed utilizing other herbicides alone or in mixtures from a different herbicide Groups that are labeled for control of these weeds and/or by using cultural or mechanical practices. However, a herbicide mode of action classification by itself may not adequately address specific weeds that are resistant to specific herbicides. Consult your local company representative, state cooperative

extension service, professional consultants or other qualified authorities to determine appropriate actions for treating specific resistant weeds.

Best Management Practices:

Proactively implementing diversified weed control strategies to minimize selection for weed populations resistant to one or more herbicides is recommended. A diversified weed management program may include the use of multiple herbicides with different modes of action and overlapping weed spectrum with or without tillage operations and/or other cultural practices. Research has demonstrated that using the labeled rate and directions for use is important to delay the selection for resistant weeds. Scouting after a herbicide application is important because it can facilitate the early identification of weed shifts and/or weed resistance and thus provide direction on future weed management practices. One of the best ways to contain resistant weed populations is to implement measures to avoid allowing weeds to reproduce by seed or to proliferate vegetatively. Cleaning equipment between sites and avoiding movement of plant material between sites will greatly aid in reducing the spread of resistant weed seed.

Plants Controlled

Woody Plant Species

alder	dogwood	salt cedar ²
arrowwood	elderberry	salmonberry
ash	elm	sassafras
aspen	gallberry	scotch broom
Australian pine	hazel	sumac
bear clover (bearmat)	hornbean	sweetbay magnolia
beech	kudzu ¹	sweetgum
birch	locust	sycamore
blackberry	madrone	tanoak
blackgum	maples	thimbleberry
Brazilian pepper	mulberry	tulip poplar
cascara	oaks	waxmyrtle
ceanothus	persimmon	western hemlock
cherry	pine	wild rose
chinquapin	poison ivy	willow
choke cherry	poison oak	winged elm
cottonwood	poplar	
crataegus	salt-bush	
(hawthorn)	(<i>Baccharis</i> spp.)	
Douglas fir		

¹For complete control, re-treatment may be necessary.

²Use cut surface treatments for best results.

Annual and Perennial Broadleaf Weeds

bindweed	Mexican petunia	tansy ragwort
burdock	plantain	tropical soda apple
Canada thistle	purple loosestrife	vetch
chicory	ragweed	wedelia
curly dock	smartweed	wild lettuce
dandelion	Spanish needles/ common beggarthicks	
field bindweed		
lambsquarter		

Purple Loosestrife (*Lythrum salicaria*)

Purple loosestrife can be controlled with foliar applications of Garlon 3A. For broadcast applications, use a minimum of 4 1/2 to 6 lb ae of triclopyr (6 to 8 quarts of Garlon 3A) per acre. Apply Garlon 3A when purple loosestrife is at the bud to mid-flowering stage of growth. Follow-up applications for control of regrowth should be made the following year in order to achieve increased control of this weed species. For all applications, a non-ionic surfactant should be added to the spray mixture.

Maximum Labeled Rate versus Spray Volume per Acre

Total Spray Volume (gal/acre)	Maximum Rate of Garlon 3A		
	Range and Pasture Sites ¹ (gal/100 gal of spray)	Forestry Sites ² (gal/100 gal of spray)	Other Non-Cropland Sites ³ (gal/100 gal of spray)
400	Do not use	0.5	0.75
300	Do not use	0.67	1
200	Do not use	1	1.5
100	0.67	2	3
50	1.33	4	6
40	1.67	5	7.5
30	2.33	6.65	10
20	3.33	10	15
10	6.67	20	30

¹Do not exceed the maximum use rate of 2 lb ae of triclopyr (2/3 gal of Garlon 3A)/acre/year.

²Do not exceed the maximum use rate of 6 lb ae of triclopyr (2 gal of Garlon 3A)/acre/year.

³Do not exceed the maximum use rate of 9 lb ae of triclopyr (3 gal of Garlon 3A)/acre/year on non-cropland use sites other than rangeland, pasture, forestry, and grazed/hayed areas.

Follow all directions and use precautions on the label of the surfactant. Thorough wetting of the foliage and stems is necessary to achieve satisfactory control. A minimum spray volume of 50 gallons per acre is needed for ground broadcast applications.

If using a backpack sprayer, a spray mixture containing 1% to 1.5% Garlon 3A or 5 to 7.6 fl oz of Garlon 3A per 4 gallons of water should be used. All purple loosestrife plants should be thoroughly wetted.

Application Methods

Use Garlon 3A at rates of 3/4 to 9 lb ae of triclopyr (1/4 to 3 gallons of Garlon 3A) per acre to control broadleaf weeds and woody plants. In all cases, use the amount specified in enough water to give uniform and complete coverage of the plants to be controlled. Use only water suitable for spraying. Use an agriculturally labeled non-ionic surfactant for all foliar applications. When using surfactants, follow the use directions and precautions listed on the surfactant manufacturer's label. Use the higher concentrations of surfactant in the spray mixture when applying lower spray volumes per acre. The order of addition to the spray tank is water, spray thickening agent (if used), additional herbicide (if used), and Garlon 3A. Surfactant should be added to the spray tank last or as recommended on the product label. If combined with emulsifiable concentrate herbicides, moderate continuous adequate agitation is required.

Before using any recommended tank mixtures, read the directions and all use precautions on both labels. **Note:** If tank mixing with Rodeo[®] herbicide, mix the Garlon 3A with at least 75% of the total spray volume desired and ensure that Garlon 3A is well mixed before adding the Rodeo to avoid incompatibility.

For best results, apply when woody plants and weeds are actively growing. When hard to control species such as ash, blackgum, choke cherry, elm, maples, oaks, pines, or winged elm are prevalent and during applications made in late summer when the plants are mature and during drought conditions, use the higher rates of Garlon 3A alone or in combination with Tordon[®] 101 Mixture specialty herbicide. (Tordon 101 Mixture is a restricted use pesticide. See product label.) Tordon 101 Mixture is not registered for use in the states of California and Florida.

When using Garlon 3A in combination with 2,4-D 3.8 lb amine, like DMA 4 IVM, or low volatile ester herbicides, generally the higher rates should be used for satisfactory brush control.

Use the higher dosage rates when brush approaches an average of 15 feet in height or when the brush covers more than 60% of the area to be treated. If lower rates are used on hard to control species, respousing may occur the year following treatment.

On sites where easy to control brush species dominate, rates less than those listed may be effective. Consult State or Local Extension personnel for such information.

**Foliage Treatment With Ground Equipment
High Volume Foliage Treatment**

For control of woody plants, use Garlon 3A at the rate of 3 to 9 lb ae of triclopyr (1 to 3 gallons of Garlon 3A) per 100 gallons of spray solution, or Garlon 3A at 3/4 to 3 lb ae of triclopyr (1 to 4 quarts of Garlon 3A) may be tank mixed with 2,4-D amine, like DMA 4 IVM, or low volatile ester or Tordon 101 Mixture and diluted to make 100 gallons of spray solution. Apply at a volume of 100 to 400 gallons of total spray per acre depending upon size and density of woody plants. Coverage should be thorough to wet all leaves, stems, and root collars. (See Use Precautions and Restrictions.) Do not exceed maximum allowable use rates per acre (see table below). Tordon 101 Mixture is not registered for use in the states of California and Florida.

Low Volume Foliage Treatment

To control susceptible woody plants, apply up to 15 lb ae of triclopyr (5 gallons of Garlon 3A) in 10 to 100 gallons of finished spray. The maximum volume of the finish spray applied to an acre is limited by the maximum use rate per site type (See Maximum Use Rates section - Range and Pasture, Grazing, Haying sites 2 lb ae, Forestry sites 6 lb ae, and all other sites 9 lb ae triclopyr). The spray concentration of Garlon 3A and total spray volume per acre should be adjusted according to the size and density of target woody plants and kind of spray equipment used. With low volume sprays, use sufficient spray volume to obtain uniform coverage of target plants including the surfaces of all foliage, stems, and root collars (see General Use Precautions and Restrictions). For best results, a surfactant should be added to all spray mixtures. Match equipment and delivery rate of spray nozzles to height and density of woody plants. When treating tall, dense brush, a truck mounted spray gun with spray tips that deliver up to 2 gallons per minute at 40 to 60 psi may be required. Backpack or other types of specialized spray equipment with spray tips that deliver less than 1 gallon of spray per minute may be appropriate for short, low to moderate density brush.

Tank Mixing: As a low volume foliar spray, up to 9 lb ae of triclopyr (3 gallons of Garlon 3A) may be applied in tank mix combination with Tordon K or Tordon 101 Mixture in 10 to 100 gallons of finished spray. The maximum volume of the finish spray applied to an acre is limited by the maximum use rate per site type (See Maximum Use Rates section - Range and Pasture, Grazing, Haying sites 2 lb ae, Forestry sites 6 lb ae, and all other sites 9 lb ae triclopyr). Tordon 101 Mixture and Tordon K are not registered for use in the states of California and Florida.

When applying this product in tank mix combination, follow all applicable use directions, precautions and limitations on each manufacturer's label. **Note:** If tank mixing with Rodeo[®] herbicide, mix the Garlon 3A with at least 75% of the total spray volume desired and ensure that Garlon 3A is well mixed before adding the Rodeo to avoid incompatibility.

Broadcast Applications With Ground Equipment

Apply using equipment that will assure uniform coverage of the spray volumes applied. To improve spray coverage, add an agriculturally labeled non-ionic surfactant as described later under Directions for Use. See Maximum Labeled Rate versus Spray Volume per Acre table above for relationship between mixing rate, spray volume and maximum application rate.

Woody Plant Control

Foliage Treatment: Use 6 to 9 lb ae of triclopyr (2 to 3 gallons of Garlon 3A) in enough water to make 20 to 100 gallons of total spray per acre or 1 1/2 to 3 lb ae of triclopyr (1/2 to 1 gallon of Garlon 3A) may be combined with 2,4-D amine, like DMA 4 IVM, or low volatile esters or Tordon 101 Mixture in sufficient water to make 20 to 100 gallons of total spray per acre. Tordon 101 Mixture is not registered for use in the states of California and Florida.

Broadleaf Weed Control

Use Garlon 3A at rates of 1 to 4 1/2 lb ae of triclopyr (1/3 to 1 1/2 gallons of Garlon 3A) in a total volume of 20 to 100 gallons of water per acre. Apply any time during the growing season. Garlon 3A at 1 to 3 lb ae of triclopyr (1/3 to 1 gallon of Garlon 3A) may be tank mixed with Tordon K, Tordon 101 Mixture or 2,4-D amine, like DMA 4 IVM, or low volatile herbicides to improve the spectrum of activity. Tordon 101 Mixture and Tordon K are not registered for use in the states of California and Florida.

Aerial Application (Helicopter Only)

Aerial sprays should be applied using suitable drift control. (See Use Precautions and Restrictions.) Add an agriculturally labeled non-ionic surfactant as described under Directions for Use. See Maximum Labeled Rate versus Spray Volume per Acre table above for relationship between mixing rate, spray volume and maximum application rate.

Foliage Treatment (Non-Grazed Rights-of-Way)

Non-grazed areas: Use 6 to 9 lb ae of triclopyr (2 to 3 gallons of Garlon 3A) or 3 to 4 1/2 lb ae of triclopyr (1 to 1 1/2 gallons of Garlon 3A) in a tank mix combination with 2,4-D amine, like DMA 4 IVM, or low volatile esters or Tordon 101 Mixture, and apply in a total spray volume of 10 to 30 gallons per acre. Use the higher rates and volumes when plants are dense or under drought conditions. Tordon 101 Mixture is not registered for use in the states of California and Florida.

Interspersed areas in non-grazed rights-of-ways that may be subject to grazing may be spot treated if the treated area comprises no more than 10% of the total grazable area.

Cut Surface Treatments

Individual plant treatments such as basal bark and cut surface applications may be used on any use site listed on this label at a maximum use rate of 2.67 gallons of Garlon 3A (8 lb ae of triclopyr) per acre. These types of applications are made directly to ungrazed parts of plants and, therefore, are not restricted by the grazing maximum rate of 2/3 of a gallon of Garlon 3A (2 lb ae of triclopyr) per acre.

To control unwanted trees of hardwood species such as elm, maple, oak and conifers in labeled sites, apply Garlon 3A, either undiluted or diluted in a 1 to 1 ratio with water, as directed below.

With Tree Injector Method

Apply by injecting 1/2 milliliter of undiluted Garlon 3A or 1 milliliter of the diluted solution through the bark at intervals of 3 to 4 inches between centers of the injector wound. The injections should completely surround the tree at any convenient height. **Note: No Worker Protection Standard worker entry restrictions or worker notification requirements apply when this product is injected directly into plants.**

With Hack and Squirt Method

Make cuts around the tree trunk at a convenient height with a hatchet or similar equipment so that the cuts overlap slightly and make a continuous circle around the trunk. Spray 1/2 milliliter of undiluted Garlon 3A or 1 milliliter of the diluted solution into the pocket created between the bark and the inner stem/trunk by each cut.

With Frill or Girdle Method

Make a single girdle through the bark completely around the tree at a convenient height. The frill should allow for the herbicide to remain next to the inner stem and absorb into the plant. Wet the cut surface with undiluted or diluted solution.

Both of the above methods may be used successfully at any season except during periods of heavy sap flow of certain species - for example, maples.

Stump Treatment

Spray or paint the cut surfaces of freshly cut stumps and stubs with undiluted Garlon 3A. The cambium area next to the bark is the most vital area to wet.

Forest Management Applications

For best control from broadcast applications of Garlon 3A, use a spray volume which will provide thorough plant coverage. Recommended spray volumes are usually 10 to 25 gallons per acre by air or 10 to 100 gallons per acre by ground. To improve spray coverage of spray volumes less than 50 gallons per acre, add an agriculturally labeled non-ionic surfactant as described under Directions for Use. Application systems should be used to prevent hazardous drift to off-target sites. Nozzles or additives that produce larger droplets of spray may require higher spray volumes to maintain brush control.

Forest Site Preparation (Not for Conifer Release)

Use up to 6 lb ae of triclopyr (2 gallons of Garlon 3A) and apply in a total spray volume of 10 to 30 gallons per acre or Garlon 3A at 3 to 4 1/2 lb ae of triclopyr (1 to 1 1/2 gallons of Garlon 3A) may be used with Tordon 101 Mixture or 2,4-D low volatile ester in a tank mix combination in a total spray volume of 10 to 30 gallons per acre. Use a non-ionic agricultural surfactant for all foliar applications as described under Directions for Use. Tordon 101 Mixture is not registered for use in the states of California and Florida.

Note: Conifers planted sooner than one month after treatment with Garlon 3A at less than 4 lb ae of triclopyr (1 1/3 gallons of Garlon 3A) per acre or sooner than two months after treatment at 4 to 6 lb ae of triclopyr (1 1/3 to 2 gallons of Garlon 3A) per acre may be injured. When tank mixtures of herbicides are used for forest site preparation, labels for all products in the mixture must be consulted and the longest recommended waiting period before planting observed.

Directed Spray Applications for Conifer Release

To release conifers from competing hardwoods such as red maple, sugar maple, striped maple, sweetgum, red and white oaks, ash, hickory, alder, birch, aspen, and pin cherry, mix 3 to 6 lb ae of triclopyr (1 to 2 gallons of Garlon 3A) in enough water to make 100 gallons of spray mixture. To improve spray coverage, add an agriculturally labeled non-ionic surfactant as described under Directions for Use. The spray mixture should be directed onto foliage of competitive hardwoods using knapsack or backpack sprayers with flat fan nozzles or equivalent any time after hardwoods have reached full leaf size, but before autumn coloration. The majority of treated hardwoods should be less than 6 feet in height to ensure adequate spray coverage. Care should be taken to direct spray away from contact with conifer foliage, particularly foliage of desirable pines.

Note: Spray may cause temporary damage and growth suppression where contact with conifers occurs; however, injured conifers should recover and grow normally. Over-the-top spray applications can kill pines.

Broadcast Applications for Conifer Release in the Northeastern United States

To release spruce, fir, red pine and white pine from competing hardwoods, such as red maple, sugar maple, striped maple, alder, birch (white, yellow or gray), aspen, ash, pin cherry and *Rubus* spp. and perennial and annual broadleaf weeds, use Garlon 3A at rates of 1 1/2 to 3 lb ae of triclopyr (2 to 4 quarts of Garlon 3A) per acre alone or with 2,4-D amine, like DMA 4 IVM, or 2,4-D ester to provide no more than 4 lb ae per acre

from both products. Apply in late summer or early fall after conifers have formed their over wintering buds and hardwoods are in full leaf and prior to autumn coloration.

Broadcast Applications for Douglas-Fir Release in the Pacific Northwest and California

To release Douglas-fir from susceptible competing vegetation such as broadleaf weeds, alder, blackberry or Scotch broom, apply Garlon 3A at 1 to 1 1/2 lb ae of triclopyr (1 1/3 to 2 quarts of Garlon 3A) per acre alone or in combination with 4 lb per acre of atrazine. Mix all sprays in a water carrier with a non-ionic surfactant. Apply in early spring after hardwoods begin growth and before Douglas fir bud break ("early foliar" hardwood stage) or after Douglas fir seasonal growth has "hardened off" (set winter buds) in late summer, but while hardwoods are still actively growing. When treating after Douglas fir bud set, apply prior to onset of autumn coloration in hardwood foliage. **Note:** Treatments applied during active Douglas fir shoot growth (after spring bud break and prior to bud set) may cause injury to Douglas fir trees.

Christmas Tree Plantations

Use Garlon 3A for the control of woody plants and annual and perennial broadleaf weeds in established Christmas tree plantations. For best results, apply when woody plants and weeds are actively growing. Garlon 3A does not control weeds which have not emerged at the time of application. If lower rates are used on hard to control woody species, resprouting may occur the year following treatment. Brush over 8 feet tall is difficult to treat efficiently using hand equipment such as backpack or knapsack sprayers. When treating large brush or trees or hard to control species such as ash, blackgum, choke cherry, elm, hazel, madrone, maples, oaks or sweetgum, and for applications made during drought conditions or in late summer when the leaves are mature, use the higher rates of Garlon 3A or use cut surface application methods. For foliar applications, apply in enough water to give uniform and complete coverage of the plants to be controlled. Applications made under drought conditions may provide less than desirable results.

Use Precautions:

- Newly seeded turf (alleyways, etc.) should be mowed two or three times before any treatment with Garlon 3A.

Use Restrictions:

- Do not use on newly seeded grass until well established as indicated by vigorous growth and development of secondary root system and tillering
- Do not reseed Christmas tree areas treated with Garlon 3A for a minimum of three weeks after application.
- Do not use Garlon 3A if legumes, such as clover, are present and injury cannot be tolerated.

Spray Preparation

The order of addition to the spray tank is water, drift control agent (if used), non-ionic agricultural surfactant and Garlon 3A. Continue moderate agitation while mixing and spraying. Use a non-ionic agricultural surfactant for all applications. When using surfactants, follow use directions and precautions listed on the manufacturer's label. Use the higher recommended concentrations of surfactant in the spray mixture when applying lower spray volumes per acre. **Note:** If tank mixing with Rodeo herbicide, mix the Garlon 3A with at least 75% of the total spray volume desired and ensure that Garlon 3A is well mixed before adding the Rodeo to avoid incompatibility.

Application

Apply in late summer or early autumn after terminal growth of Christmas trees has hardened off, but before leaf drop of, target weeds. Apply at a rate of 3/4 to 1 3/4 lb ae of triclopyr (2 to 5 pints of Garlon 3A) per acre as a foliar spray directed toward the base of Christmas trees. Use sufficient spray volume to provide uniform coverage of target plants (20 to 100 gallons per acre). **Do not apply with 2,4-D.** Application rates of Garlon 3A directed for Christmas trees will only suppress some well established woody plants that are greater than 2 to 3 years old (see table below). Broadcast sprays may also be applied in bands between the rows of planted trees. Use spray equipment that will assure uniform coverage of the desired spray volume.

Spray solution from Garlon 3A can cause needle and branch injury to Christmas trees. To minimize injury to Christmas trees, direct sprays so as to minimize contact with foliage. Blue spruce, white spruce, balsam fir and Fraser fir are less susceptible to injury than white pine and Douglas fir.

Restriction: Apply Garlon 3A only to established Christmas trees that were planted at least one full year prior to application.

Application Rates and Species Controlled:

Garlon 3A		
2 pints/acre (3/4 lb ae of triclopyr)	3 to 4 pints/acre (1 1/2 lb ae of triclopyr)	5 pints/acre (1 3/4 lb ae of triclopyr)
clover	bindweed, field (TG)	arrowwood (SDL)
dandelion	blackberry ¹	aspen
dock, curly	chicory (s)	beech (SDL)
lambsquarters	fireweed	birch (SDL)
lespedeza	ivy, ground	chinquapin
plantain, broadleaf	lettuce, wild	cottonwood (SDL)
plantain, buckhorn	oxalis	elderberry
ragweed, common	poison ivy	grape, wild
vetch	smartweed (TG)	mulberry (SDL)
	thistle, Canada (TG)	poplar (SDL)
	violet, wild	sassafras (SDL)
	Virginia creeper ¹	sumac (SDL)
		sycamore (SDL)

(TG) Top growth control, retreatment may be necessary

(S) Suppression

(SDL) Seedlings less than 2 to 3 years old

¹Use 4 pint per acre rate

Directed Applications

To control hardwoods such as red maple, sugar maple, striped maple, sweetgum, red and white oaks, ash, alder, birch, aspen, and pin cherry, mix 4 to 20 fl oz of Garlon 3A in enough water to make 3 gallons of spray mixture. For directed applications, do not exceed 6 lb ae of triclopyr (2 gallons of Garlon 3A) per acre per year. To improve coverage, add a non-ionic agricultural surfactant to the spray. This spray mixture should be directed onto foliage of competitive hardwoods using knapsack or backpack sprayers with flat fan nozzles or equivalent any time after hardwoods have reached full leaf size, but before autumn coloration (when plants are actively growing). The majority of treated hardwoods should be less than 8 feet in height to ensure adequate spray coverage. **Note:** To prevent Christmas tree injury, care should be taken to direct spray away from contact with Christmas tree foliage.

Cut Surface Treatments

When treating large brush or trees or hard to control species such as ash, blackgum, choke cherry, elm, hazel, madrone, maples, oaks, salt cedar or sweetgum, and for applications made during drought conditions or in late summer when the leaves are mature, use cut surface treatments. (See directions for Cut Surface Treatments in preceding section of this label.)

Wetland Sites in Forests and Non-Crop Areas

Garlon 3A may be used within forests and non-crop sites to control target vegetation in and around standing water sites, such as marshes, wetlands, and the banks of ponds and lakes and transition areas between upland and lowland sites.

For control of woody plants and broadleaf weeds in these sites, follow use directions and application methods on this label for forestry and non-cropland sites.

Use Precautions:

Minimize overspray to open water when treating target vegetation in and around non-flowing, quiescent or transient water. When making applications to control unwanted plants on banks or shorelines of flowing water, minimize overspray to open water. **Note:** Consult local public water control authorities before applying this product in and around public water. Permits may be required to treat such areas.

Terms and Conditions of Use

If terms of the following Warranty Disclaimer, Inherent Risks of Use, and Limitation of Remedies are not acceptable, return unopened package at once to the seller for a full refund of purchase price paid. To the extent permitted by law, otherwise, use by the buyer or any other user constitutes acceptance of the terms under Warranty Disclaimer, Inherent Risks of Use and Limitations of Remedies.

Warranty Disclaimer

Dow AgroSciences warrants that this product conforms to the chemical description on the label and is reasonably fit for the purposes stated on the label when used in strict accordance with the directions, subject to the inherent risks set forth below. To the extent permitted by law, Dow AgroSciences MAKES NO OTHER EXPRESS OR IMPLIED WARRANTY OF MERCHANTABILITY OR FITNESS FOR A PARTICULAR PURPOSE OR ANY OTHER EXPRESS OR IMPLIED WARRANTY.

Inherent Risks of Use

It is impossible to eliminate all risks associated with use of this product. Plant injury, lack of performance, or other unintended consequences may result because of such factors as use of the product contrary to label instructions (including conditions noted on the label, such as unfavorable temperature, soil conditions, etc.), abnormal conditions (such as excessive rainfall, drought, tornadoes, hurricanes), presence of other materials, the manner of application, or other factors, all of which are beyond the control of Dow AgroSciences or the seller. All such risks shall be assumed by buyer.

Limitation of Remedies

To the extent permitted by law, the exclusive remedy for losses or damages resulting from this product (including claims based on contract, negligence, strict liability, or other legal theories), shall be limited to, at Dow AgroSciences' election, one of the following:

1. Refund of purchase price paid by buyer or user for product bought, or
2. Replacement of amount of product used.

Dow AgroSciences shall not be liable for losses or damages resulting from handling or use of this product unless Dow AgroSciences is promptly notified of such loss or damage in writing. To the extent permitted by law, in no case shall Dow AgroSciences be liable for consequential or incidental damages or losses.

The terms of the Warranty Disclaimer, Inherent Risks of Use, and this Limitation of Remedies cannot be varied by any written or verbal statements or agreements. No employee or sales agent of Dow AgroSciences or the seller is authorized to vary or exceed the terms of the Warranty Disclaimer or this Limitation of Remedies in any manner.

®Trademark of The Dow Chemical Company ("Dow") or an affiliated company of Dow

**Produced for
Dow AgroSciences LLC
9330 Zionsville Road
Indianapolis, IN 46268**

Label Code: D02-101-041
Replaced Label: D02-101-040
LOES Number: 010-00084
EPA accepted 02/25/16

Revisions:

1. Added Crop Group 4 Herbicide box MOA, Weed Resistance Management and Best Management Practices language.
2. Updated Active Ingredient section.
3. Updated the Hazard to Human and Domestic Animals section.
4. Updated language under Engineering Controls section.
5. Updated the User Safety Recommendations section.
6. Updated the Use Precautions and Use Restrictions sections.
7. Added the title for Maximum Use Rates section and updated section.
8. Added/updated the Grazing and Haying Restriction as follow:

Grazing and Haying Restrictions

Grazing green forage:

- There are no grazing restrictions for livestock or dairy animals on treated areas.

Haying (harvesting of dried forage)

- Do not harvest hay for 14 days after application.

- #### **Slaughter Restrictions:** During the season of application, withdraw livestock from grazing treated grass at least 3 days before slaughter.
9. Removed all tank mix partner rates throughout the label.
 10. Added the following sentence to direct users to the Maximum Use Rates section: The maximum volume of the finish spray applied to an acre is limited by the maximum use rate per site type (See Maximum Use Rates section - Range and Pasture, Grazing, Haying sites 2 lb ae, Forestry sites 6 lb ae, and all other sites 9 lb ae triclopyr).
 11. Corrected 4 to 9 lb ae of triclopyr to 4 to 6 lb and update 3 gallons of Garlon 3A to 2 gallons.
 12. Changed the word recommended to directed throughout the label.

SAFETY DATA SHEET

DOW AGROSCIENCES LLC

Product name: GARLON™ 4 Ultra Herbicide

Issue Date: 05/04/2015

Print Date: 05/17/2015

DOW AGROSCIENCES LLC encourages and expects you to read and understand the entire (M)SDS, as there is important information throughout the document. We expect you to follow the precautions identified in this document unless your use conditions would necessitate other appropriate methods or actions.

1. IDENTIFICATION

Product name: GARLON™ 4 Ultra Herbicide

Recommended use of the chemical and restrictions on use

Identified uses: End use herbicide product

COMPANY IDENTIFICATION

DOW AGROSCIENCES LLC
9330 ZIONSVILLE RD
INDIANAPOLIS IN 46268-1053
UNITED STATES

Customer Information Number:

800-992-5994

info@dow.com

EMERGENCY TELEPHONE NUMBER

24-Hour Emergency Contact: 800-992-5994

Local Emergency Contact: 352-323-3500

2. HAZARDS IDENTIFICATION

Hazard classification

This material is hazardous under the criteria of the Federal OSHA Hazard Communication Standard 29CFR 1910.1200.

Skin sensitisation - Sub-category 1B

Label elements

Hazard pictograms



Signal word: **WARNING!**

Hazards

May cause an allergic skin reaction.

Precautionary statements**Prevention**

Avoid breathing dust/ fume/ gas/ mist/ vapours/ spray.

Contaminated work clothing should not be allowed out of the workplace.

Wear protective gloves.

Response

IF ON SKIN: Wash with plenty of soap and water.

If skin irritation or rash occurs: Get medical advice/ attention.

Wash contaminated clothing before reuse.

Disposal

Dispose of contents/ container to an approved waste disposal plant.

Other hazards

no data available

3. COMPOSITION/INFORMATION ON INGREDIENTS

Chemical nature: Mixture

This product is a mixture.

Component	CASRN	Concentration
Triclopyr-2-butoxyethyl ester	64700-56-7	60.5%
Ethylene glycol monobutyl ether	111-76-2	0.5%
Balance	Not available	39.0%

4. FIRST AID MEASURES

Description of first aid measures

General advice: First Aid responders should pay attention to self-protection and use the recommended protective clothing (chemical resistant gloves, splash protection). If potential for exposure exists refer to Section 8 for specific personal protective equipment.

Inhalation: Move person to fresh air. If person is not breathing, call an emergency responder or ambulance, then give artificial respiration; if by mouth to mouth use rescuer protection (pocket mask etc). Call a poison control center or doctor for treatment advice.

Skin contact: Take off contaminated clothing. Wash skin with soap and plenty of water for 15-20 minutes. Call a poison control center or doctor for treatment advice. Wash clothing before reuse. Shoes and other leather items which cannot be decontaminated should be disposed of properly.

Eye contact: Hold eyes open and rinse slowly and gently with water for 15-20 minutes. Remove contact lenses, if present, after the first 5 minutes, then continue rinsing eyes. Call a poison control center or doctor for treatment advice.

Ingestion: Call a poison control center or doctor immediately for treatment advice. Have person sip a glass of water if able to swallow. Do not induce vomiting unless told to do so by the poison control center or doctor. Never give anything by mouth to an unconscious person.

Most important symptoms and effects, both acute and delayed: Aside from the information found under Description of first aid measures (above) and Indication of immediate medical attention and special treatment needed (below), any additional important symptoms and effects are described in Section 11: Toxicology Information.

Indication of any immediate medical attention and special treatment needed

Notes to physician: No specific antidote. Treatment of exposure should be directed at the control of symptoms and the clinical condition of the patient. Have the Safety Data Sheet, and if available, the product container or label with you when calling a poison control center or doctor, or going for treatment.

5. FIREFIGHTING MEASURES

Suitable extinguishing media: Water fog or fine spray. Dry chemical fire extinguishers. Carbon dioxide fire extinguishers. Foam. Alcohol resistant foams (ATC type) are preferred. General purpose synthetic foams (including AFFF) or protein foams may function, but will be less effective. Water fog, applied gently may be used as a blanket for fire extinguishment.

Unsuitable extinguishing media: Do not use direct water stream. May spread fire.

Special hazards arising from the substance or mixture

Hazardous combustion products: During a fire, smoke may contain the original material in addition to combustion products of varying composition which may be toxic and/or irritating. Combustion products may include and are not limited to: Nitrogen oxides. Hydrogen chloride. Carbon monoxide. Carbon dioxide. Phosgene.

Unusual Fire and Explosion Hazards: Container may rupture from gas generation in a fire situation. Violent steam generation or eruption may occur upon application of direct water stream to hot liquids.

Advice for firefighters

Fire Fighting Procedures: Keep people away. Isolate fire and deny unnecessary entry. Use water spray to cool fire exposed containers and fire affected zone until fire is out and danger of reignition has passed. Fight fire from protected location or safe distance. Consider the use of unmanned hose holders or monitor nozzles. Immediately withdraw all personnel from the area in case of rising sound from venting safety device or discoloration of the container. Do not use direct water stream. May spread fire. Move container from fire area if this is possible without hazard. Burning liquids may be moved by flushing with water to protect personnel and minimize property damage. Water fog, applied gently may be used as a blanket for fire extinguishment. Contain fire water run-off if possible. Fire water run-off, if not contained, may cause environmental damage. Review the "Accidental Release Measures" and the "Ecological Information" sections of this (M)SDS.

Special protective equipment for firefighters: Wear positive-pressure self-contained breathing apparatus (SCBA) and protective fire fighting clothing (includes fire fighting helmet, coat, trousers, boots, and gloves). Avoid contact with this material during fire fighting operations. If contact is likely, change to full chemical resistant fire fighting clothing with self-contained breathing apparatus. If this is

not available, wear full chemical resistant clothing with self-contained breathing apparatus and fight fire from a remote location. For protective equipment in post-fire or non-fire clean-up situations, refer to the relevant sections.

6. ACCIDENTAL RELEASE MEASURES

Personal precautions, protective equipment and emergency procedures: Isolate area. Keep unnecessary and unprotected personnel from entering the area. Refer to section 7, Handling, for additional precautionary measures. Use appropriate safety equipment. For additional information, refer to Section 8, Exposure Controls and Personal Protection.

Environmental precautions: Prevent from entering into soil, ditches, sewers, waterways and/or groundwater. See Section 12, Ecological Information.

Methods and materials for containment and cleaning up: Contain spilled material if possible. Small spills: Absorb with materials such as: Clay. Dirt. Sand. Sweep up. Collect in suitable and properly labeled containers. Large spills: Contact Dow AgroSciences for clean-up assistance. See Section 13, Disposal Considerations, for additional information.

7. HANDLING AND STORAGE

Precautions for safe handling: Keep out of reach of children. Do not swallow. Avoid breathing vapor or mist. Avoid contact with eyes, skin, and clothing. Use with adequate ventilation. Wash thoroughly after handling. See Section 8, EXPOSURE CONTROLS AND PERSONAL PROTECTION.

Conditions for safe storage: Store in a dry place. Store in original container. Keep container tightly closed when not in use. Do not store near food, foodstuffs, drugs or potable water supplies.

8. EXPOSURE CONTROLS/PERSONAL PROTECTION

Control parameters

Exposure limits are listed below, if they exist.

Component	Regulation	Type of listing	Value/Notation
Triclopyr-2-butoxyethyl ester	Dow IHG	TWA	2 mg/m ³
	Dow IHG	TWA	SKIN, DSEN, BEI
Ethylene glycol monobutyl ether	ACGIH	TWA	20 ppm
	OSHA Z-1	TWA	240 mg/m ³ 50 ppm
	ACGIH	TWA	BEI
	OSHA Z-1	TWA	Absorbed via skin

RECOMMENDATIONS IN THIS SECTION ARE FOR MANUFACTURING, COMMERCIAL BLENDING AND PACKAGING WORKERS. APPLICATORS AND HANDLERS SHOULD SEE THE PRODUCT LABEL FOR PROPER PERSONAL PROTECTIVE EQUIPMENT AND CLOTHING.

Exposure controls

Engineering controls: Use local exhaust ventilation, or other engineering controls to maintain airborne levels below exposure limit requirements or guidelines. If there are no applicable exposure limit requirements or guidelines, general ventilation should be sufficient for most operations.

Individual protection measures

Eye/face protection: Use safety glasses (with side shields).

Skin protection

Hand protection: Use gloves chemically resistant to this material. Examples of preferred glove barrier materials include: Butyl rubber. Chlorinated polyethylene. Neoprene. Polyethylene. Ethyl vinyl alcohol laminate ("EVAL"). Examples of acceptable glove barrier materials include: Natural rubber ("latex"). Viton. Polyvinyl chloride ("PVC" or "vinyl"). Nitrile/butadiene rubber ("nitrile" or "NBR"). NOTICE: The selection of a specific glove for a particular application and duration of use in a workplace should also take into account all relevant workplace factors such as, but not limited to: Other chemicals which may be handled, physical requirements (cut/puncture protection, dexterity, thermal protection), potential body reactions to glove materials, as well as the instructions/specifications provided by the glove supplier.

Other protection: Use protective clothing chemically resistant to this material. Selection of specific items such as face shield, boots, apron, or full body suit will depend on the task.

Respiratory protection: Respiratory protection should be worn when there is a potential to exceed the exposure limit requirements or guidelines. If there are no applicable exposure limit requirements or guidelines, wear respiratory protection when adverse effects, such as respiratory irritation or discomfort have been experienced, or where indicated by your risk assessment process. For most conditions no respiratory protection should be needed; however, if discomfort is experienced, use an approved air-purifying respirator. The following should be effective types of air-purifying respirators: Organic vapor cartridge with a particulate pre-filter.

9. PHYSICAL AND CHEMICAL PROPERTIES

Appearance

Physical state	Liquid.
Color	Yellow
Odor	Mild
Odor Threshold	no data available
pH	3.36 1% pH Electrode (1% aqueous suspension)
Melting point/range	Not applicable
Freezing point	No test data available
Boiling point (760 mmHg)	No test data available
Flash point	closed cup > 100 °C (> 212 °F) <i>Pensky-Martens Closed Cup ASTM D 93</i>
Evaporation Rate (Butyl Acetate = 1)	No test data available
Flammability (solid, gas)	no data available
Lower explosion limit	No test data available
Upper explosion limit	No test data available
Vapor Pressure	No test data available
Relative Vapor Density (air = 1)	No test data available
Relative Density (water = 1)	1.11 at 20 °C (68 °F) <i>Digital Density Meter (Oscillating Coil)</i>
Water solubility	emulsifies

Partition coefficient: n-octanol/water	no data available
Auto-ignition temperature	> 325 °C (> 617 °F)
Decomposition temperature	No test data available
Dynamic Viscosity	23.4 mPa.s at 20 °C (68 °F) 10.8 mPa.s at 40 °C (104 °F)
Kinematic Viscosity	No test data available
Explosive properties	No
Oxidizing properties	No significant increase (>5C) in temperature.
Liquid Density	1.11 g/cm ³ at 20 °C (68 °F) <i>Digital density meter</i>
Molecular weight	no data available

NOTE: The physical data presented above are typical values and should not be construed as a specification.

10. STABILITY AND REACTIVITY

Reactivity: no data available

Chemical stability: Thermally stable at typical use temperatures.

Possibility of hazardous reactions: Polymerization will not occur.

Conditions to avoid: Exposure to elevated temperatures can cause product to decompose. Generation of gas during decomposition can cause pressure in closed systems.

Incompatible materials: Avoid contact with: Strong acids. Strong bases. Strong oxidizers.

Hazardous decomposition products: Decomposition products depend upon temperature, air supply and the presence of other materials. Decomposition products can include and are not limited to: Hydrogen chloride. Nitrogen oxides. Phosgene.

11. TOXICOLOGICAL INFORMATION

Toxicological information on this product or its components appear in this section when such data is available.

Acute toxicity

Acute oral toxicity

Low toxicity if swallowed. Small amounts swallowed incidentally as a result of normal handling operations are not likely to cause injury; however, swallowing larger amounts may cause injury.

LD50, Rat, female, 3,200 mg/kg

Acute dermal toxicity

Prolonged skin contact is unlikely to result in absorption of harmful amounts.

LD50, Rat, male and female, > 5,000 mg/kg

Acute inhalation toxicity

Prolonged exposure is not expected to cause adverse effects. Based on the available data, respiratory irritation was not observed.

LC50, Rat, male and female, 4 Hour, dust/mist, > 5.05 mg/l No deaths occurred at this concentration.

Skin corrosion/irritation

Brief contact may cause moderate skin irritation with local redness. May cause drying and flaking of the skin.

Serious eye damage/eye irritation

May cause slight eye irritation. Corneal injury is unlikely.

Sensitization

Has demonstrated the potential for contact allergy in mice.

For respiratory sensitization:
No relevant data found.

Specific Target Organ Systemic Toxicity (Single Exposure)

Evaluation of available data suggests that this material is not an STOT-SE toxicant.

Specific Target Organ Systemic Toxicity (Repeated Exposure)

For the active ingredient(s):
In animals, effects have been reported on the following organs:
Kidney.
Liver.

Carcinogenicity

For the minor component(s): In long-term animal studies with ethylene glycol butyl ether, small but statistically significant increases in tumors were observed in mice but not rats. The effects are not believed to be relevant to humans. If the material is handled in accordance with proper industrial handling procedures, exposures should not pose a carcinogenic risk to man. For similar active ingredient(s). Triclopyr. Did not cause cancer in laboratory animals.

Teratogenicity

For the active ingredient(s): Has been toxic to the fetus in laboratory animals at doses toxic to the mother. Did not cause birth defects in laboratory animals.

Reproductive toxicity

For similar active ingredient(s). Triclopyr. In laboratory animal studies, effects on reproduction have been seen only at doses that produced significant toxicity to the parent animals.

Mutagenicity

For the active ingredient(s): In vitro genetic toxicity studies were negative. Animal genetic toxicity studies were negative.

Aspiration Hazard

Based on available information, aspiration hazard could not be determined.

Carcinogenicity Component	List	Classification
Ethylene glycol monobutyl ether	ACGIH	A3: Confirmed animal carcinogen with unknown relevance to humans.

12. ECOLOGICAL INFORMATION

Ecotoxicological information on this product or its components appear in this section when such data is available.

Toxicity

Acute toxicity to fish

For similar material(s):

Material is highly toxic to aquatic organisms on an acute basis (LC50/EC50 between 0.1 and 1 mg/L in the most sensitive species tested).

For similar material(s):

LC50, Lepomis macrochirus (Bluegill sunfish), 96 Hour, 0.44 mg/l, OECD Test Guideline 203 or Equivalent

LC50, Oncorhynchus mykiss (rainbow trout), 96 Hour, 0.984 mg/l, OECD Test Guideline 203 or Equivalent

Acute toxicity to aquatic invertebrates

For similar material(s):

EC50, Daphnia magna (Water flea), 48 Hour, 0.35 mg/l, OECD Test Guideline 202 or Equivalent

Acute toxicity to algae/aquatic plants

For similar material(s):

EbC50, Pseudokirchneriella subcapitata (green algae), 72 Hour, Biomass, 11 mg/l, OECD Test Guideline 201 or Equivalent

Toxicity to Above Ground Organisms

Based on information for a similar material:

Material is slightly toxic to birds on an acute basis (LD50 between 501 and 2000 mg/kg).

Based on information for a similar material:

oral LD50, Colinus virginianus (Bobwhite quail), 1,350 mg/kg

Persistence and degradability

Triclopyr-2-butoxyethyl ester

Biodegradability: Chemical degradation (hydrolysis) is expected in the environment.

Material is expected to biodegrade very slowly (in the environment). Fails to pass OECD/EEC tests for ready biodegradability.

10-day Window: Fail

Biodegradation: 18 %

Exposure time: 28 d

Method: OECD Test Guideline 301B or Equivalent

Theoretical Oxygen Demand: 1.39 mg/mg

Biological oxygen demand (BOD)

Incubation Time	BOD
	0.004 mg/mg

Stability in Water (1/2-life)

Hydrolysis, half-life, 8.7 d, pH 7, Half-life Temperature 25 °C

Photodegradation

Atmospheric half-life: 5.6 Hour

Method: Estimated.

Ethylene glycol monobutyl ether

Biodegradability: Material is readily biodegradable. Passes OECD test(s) for ready biodegradability. Material is ultimately biodegradable (reaches > 70% mineralization in OECD test(s) for inherent biodegradability).

10-day Window: Pass

Biodegradation: 90.4 %

Exposure time: 28 d

Method: OECD Test Guideline 301B or Equivalent

Theoretical Oxygen Demand: 2.30 mg/mg

Chemical Oxygen Demand: 2.21 mg/g Dichromate

Biological oxygen demand (BOD)

Incubation Time	BOD
5 d	5.2 %
10 d	57 %
20 d	72.2 %

Balance

Biodegradability: No relevant data found.

Bioaccumulative potential

Triclopyr-2-butoxyethyl ester

Bioaccumulation: Bioconcentration potential is moderate (BCF between 100 and 3000 or Log Pow between 3 and 5).

Partition coefficient: n-octanol/water(log Pow): 4.62

Bioconcentration factor (BCF): 110 Fish.

Ethylene glycol monobutyl ether

Bioaccumulation: Bioconcentration potential is low (BCF < 100 or Log Pow < 3).
Partition coefficient: n-octanol/water(log Pow): 0.81 Measured
Bioconcentration factor (BCF): 3.2

Balance

Bioaccumulation: No relevant data found.

Mobility in soil**Triclopyr-2-butoxyethyl ester**

Calculation of meaningful sorption data was not possible due to very rapid degradation in the soil.

For the degradation product:

Triclopyr.

Potential for mobility in soil is very high (Koc between 0 and 50).

Ethylene glycol monobutyl ether

Potential for mobility in soil is high (Koc between 50 and 150).

Partition coefficient(Koc): 67 Estimated.

Balance

No relevant data found.

13. DISPOSAL CONSIDERATIONS

Disposal methods: If wastes and/or containers cannot be disposed of according to the product label directions, disposal of this material must be in accordance with your local or area regulatory authorities. This information presented below only applies to the material as supplied. The identification based on characteristic(s) or listing may not apply if the material has been used or otherwise contaminated. It is the responsibility of the waste generator to determine the toxicity and physical properties of the material generated to determine the proper waste identification and disposal methods in compliance with applicable regulations. If the material as supplied becomes a waste, follow all applicable regional, national and local laws.

14. TRANSPORT INFORMATION

DOT

Not regulated for transport

Classification for SEA transport (IMO-IMDG):

Proper shipping name	ENVIRONMENTALLY HAZARDOUS SUBSTANCE, LIQUID, N.O.S.(Triclopyr-2-butoxyethyl ester)
UN number	UN 3082
Class	9
Packing group	III
Marine pollutant	Triclopyr-2-butoxyethyl ester
Transport in bulk according to Annex I or II of MARPOL 73/78 and the	Consult IMO regulations before transporting ocean bulk

IBC or IGC Code**Classification for AIR transport (IATA/ICAO):**

Proper shipping name	Environmentally hazardous substance, liquid, n.o.s.(Triclopyr-2-butoxyethyl ester)
UN number	UN 3082
Class	9
Packing group	III

This information is not intended to convey all specific regulatory or operational requirements/information relating to this product. Transportation classifications may vary by container volume and may be influenced by regional or country variations in regulations. Additional transportation system information can be obtained through an authorized sales or customer service representative. It is the responsibility of the transporting organization to follow all applicable laws, regulations and rules relating to the transportation of the material.

15. REGULATORY INFORMATION

OSHA Hazard Communication Standard

This product is a "Hazardous Chemical" as defined by the OSHA Hazard Communication Standard, 29 CFR 1910.1200.

Superfund Amendments and Reauthorization Act of 1986 Title III (Emergency Planning and Community Right-to-Know Act of 1986) Sections 311 and 312

Acute Health Hazard
Chronic Health Hazard

Superfund Amendments and Reauthorization Act of 1986 Title III (Emergency Planning and Community Right-to-Know Act of 1986) Section 313

This material does not contain any chemical components with known CAS numbers that exceed the threshold (De Minimis) reporting levels established by SARA Title III, Section 313.

California Proposition 65 (Safe Drinking Water and Toxic Enforcement Act of 1986)

This product contains no listed substances known to the State of California to cause cancer, birth defects or other reproductive harm, at levels which would require a warning under the statute.

Pennsylvania (Worker and Community Right-To-Know Act): Pennsylvania Hazardous Substances List and/or Pennsylvania Environmental Hazardous Substance List:

To the best of our knowledge, this product does not contain chemicals at levels which require reporting under this statute.

Pennsylvania (Worker and Community Right-To-Know Act): Pennsylvania Special Hazardous Substances List:

To the best of our knowledge, this product does not contain chemicals at levels which require reporting under this statute.

United States TSCA Inventory (TSCA)

This product contains chemical substance(s) exempt from U.S. EPA TSCA Inventory requirements. It is regulated as a pesticide subject to Federal Insecticide, Fungicide, and Rodenticide Act (FIFRA) requirements.

Federal Insecticide, Fungicide and Rodenticide Act

EPA Registration Number: 62719-527

This chemical is a pesticide product registered by the Environmental Protection Agency and is subject to certain labeling requirements under federal pesticide law. These requirements differ from the classification criteria and hazard information required for safety data sheets, and for workplace labels of non-pesticide chemicals. Following is the hazard information as required on the pesticide label:

CAUTION

Causes moderate eye irritation

Harmful if swallowed

Prolonged or frequently repeated skin contact may cause allergic reactions in some individuals.

16. OTHER INFORMATION

Hazard Rating System

NFPA

Health	Fire	Reactivity
2	1	0

Revision

Identification Number: 101188950 / A211 / Issue Date: 05/04/2015 / Version: 7.0

DAS Code: GF-1529

Most recent revision(s) are noted by the bold, double bars in left-hand margin throughout this document.

Legend

Absorbed via skin	Absorbed via skin
ACGIH	USA. ACGIH Threshold Limit Values (TLV)
BEI	Biological Exposure Indices
Dow IHG	Dow Industrial Hygiene Guideline
OSHA Z-1	USA. Occupational Exposure Limits (OSHA) - Table Z-1 Limits for Air Contaminants
SKIN, DSEN, BEI	Absorbed via Skin, Skin Sensitizer, Biological Exposure Indice
TWA	8-hour, time-weighted average

Information Source and References

This SDS is prepared by Product Regulatory Services and Hazard Communications Groups from information supplied by internal references within our company.

DOW AGROSCIENCES LLC urges each customer or recipient of this (M)SDS to study it carefully and consult appropriate expertise, as necessary or appropriate, to become aware of and understand the data contained in this (M)SDS and any hazards associated with the product. The information herein is provided in good faith and believed to be accurate as of the effective date shown above. However, no warranty, express or implied, is given. Regulatory requirements are subject to change and may differ

between various locations. It is the buyer's/user's responsibility to ensure that his activities comply with all federal, state, provincial or local laws. The information presented here pertains only to the product as shipped. Since conditions for use of the product are not under the control of the manufacturer, it is the buyer's/user's duty to determine the conditions necessary for the safe use of this product. Due to the proliferation of sources for information such as manufacturer-specific (M)SDSs, we are not and cannot be responsible for (M)SDSs obtained from any source other than ourselves. If you have obtained an (M)SDS from another source or if you are not sure that the (M)SDS you have is current, please contact us for the most current version.

ATTENTION:

This specimen label is provided for general information only.

- This pesticide product may not yet be available or approved for sale or use in your area.
- It is your responsibility to follow all Federal, state and local laws and regulations regarding the use of pesticides.
- Before using any pesticide, be sure the intended use is approved in your state or locality.
- Your state or locality may require additional precautions and instructions for use of this product that are not included here.
- Monsanto does not guarantee the completeness or accuracy of this specimen label. The information found in this label may differ from the information found on the product label. You must have the EPA approved labeling with you at the time of use and must read and follow all label directions.
- You should not base any use of a similar product on the precautions, instructions for use or other information you find here.
- Always follow the precautions and instructions for use on the label of the pesticide you are using.

21153L1-37



Complete Directions for Use

Roundup Custom™ for Aquatic and Terrestrial Use is a complete broad-spectrum postemergence herbicide for aquatic, crop, non-agricultural crop, industrial, turf, ornamental, forestry, roadside, and utility rights-of-way weed control.

EPA Reg. No. 524-343

2012-2

GROUP

9

HERBICIDE

AVOID CONTACT OF HERBICIDE WITH FOLIAGE, GREEN STEMS, EXPOSED NON-WOODY ROOTS OR FRUIT OF CROPS, DESIRABLE PLANTS AND TREES, BECAUSE SEVERE INJURY OR DESTRUCTION MAY RESULT.

Read the entire label before using this product.

Use only according to label instructions.

Not all products listed on this label are registered for use in California. Check the registration status of each product in California before using.

Read the "LIMIT OF WARRANTY AND LIABILITY" statement at the end of the label before buying or using. If terms are not acceptable, return at once unopened.

THIS IS AN END-USE PRODUCT. MONSANTO DOES NOT INTEND AND HAS NOT REGISTERED IT FOR REFORMULATION. SEE INDIVIDUAL CONTAINER LABEL FOR REPACKAGING LIMITATIONS.

PRODUCT INFORMATION

1.0 INGREDIENTS

ACTIVE INGREDIENT:

*Glyphosate, N-(phosphonomethyl)glycine,
in the form of its isopropylamine salt.....53.8%

OTHER INGREDIENTS:.....46.2%
100.0%

*Contains 648 grams per liter or 5.4 pounds per U.S. gallon of the active ingredient glyphosate, in the form of its isopropylamine salt. Equivalent to 480 grams per liter or 4.0 pounds per U.S. gallon of the acid, glyphosate.

No license granted under any non-U.S. patent(s).

2.0 IMPORTANT PHONE NUMBERS

FOR PRODUCT INFORMATION OR ASSISTANCE IN USING THIS PRODUCT, CALL
TOLL-FREE, 1-800-332-3111.

IN CASE OF AN EMERGENCY INVOLVING THIS PRODUCT, OR FOR MEDICAL
ASSISTANCE, CALL COLLECT, DAY OR NIGHT, (314)-694-4000.

3.0 PRECAUTIONARY STATEMENTS

3.1 Hazards to Humans and Domestic Animals

Keep Out of Reach of Children.

CAUTION!

DOMESTIC ANIMALS: This product is considered to be relatively nontoxic to dogs and other domestic animals; however, ingestion of this product or large amounts of freshly sprayed vegetation may result in temporary gastrointestinal irritation (vomiting, diarrhea, colic, etc.). If such symptoms are observed, provide the animal with plenty of fluids to prevent dehydration. Call a veterinarian if symptoms persist for more than 24 hours.

Personal Protective Equipment (PPE)

Applicators and other handlers must wear: long-sleeved shirt and long pants, shoes plus socks. Follow manufacturer's instructions for cleaning/maintaining PPE (Personal Protective Equipment). If no such instructions for washables, use detergent and hot water. Keep and wash PPE separately from other laundry.

Engineering Control Statements: When handlers use closed systems, enclosed cabs, or aircraft in a manner that meets the requirements listed in Worker Protection Standard (WPS) for agricultural pesticides [40 CFR 170.240 (d) (4-6)], the handler PPE requirements may be reduced or modified as specified in the WPS.

User Safety Recommendations:

Users should:

- Wash hands before eating, drinking, chewing gum, using tobacco, or using the toilet.
- Remove contaminated clothing and wash clothing before reuse.

3.2 Environmental Hazards

Do not contaminate water when cleaning equipment or disposing of equipment washwaters. Treatment of aquatic weeds can result in oxygen depletion or loss due to decomposition of dead plants. This oxygen loss can cause fish suffocation.

In case of SPILL or LEAK, soak up and remove to a landfill.

3.3 Physical or Chemical Hazards

Spray solutions of this product should be mixed, stored and applied using only stainless steel, fiberglass, plastic or plastic-lined steel containers.

DO NOT MIX, STORE OR APPLY THIS PRODUCT OR SPRAY SOLUTIONS OF THIS PRODUCT IN GALVANIZED STEEL OR UNLINED STEEL (EXCEPT STAINLESS STEEL) CONTAINERS OR SPRAY TANKS. This product or spray solutions of this product react with such containers and tanks to produce hydrogen gas which may form a highly combustible gas mixture. This gas mixture could flash or explode, causing serious personal injury, if ignited by open flame, spark, welder's torch, lighted cigarette or other ignition source.

DIRECTIONS FOR USE

It is a violation of Federal law to use this product in any manner inconsistent with its labeling. This product can only be used in accordance with the Directions for Use on this label or in separately published Monsanto Supplemental Labeling or Fact Sheets. Supplemental labeling can be found on the Internet at www.cdms.net, www.agrian.com or www.greenbook.net websites but may not be approved for use in all states. Copies can also be obtained by contacting your Authorized Monsanto Retailer or Monsanto Company Representative.

Do not apply this product in a way that will contact workers or other persons, either directly or through drift. Only protected handlers may be in the area during application. For any

requirements specific to your State or Tribe, consult the agency responsible for pesticide regulations.

Agricultural Use Requirements

Use this product only in accordance with its labeling and with the Worker Protection Standard, 40 CFR Part 170. This Standard contains requirements for the protection of agricultural workers on farms, forests, nurseries, and greenhouses, and handlers of agricultural pesticides. It contains requirements for training, decontamination, notification, and emergency assistance. It also contains specific instructions and exceptions pertaining to the statements on this label about personal protective equipment (PPE) and restricted entry interval. The requirements in this box only apply to uses of this product that are covered by the Worker Protection Standard.

Do not enter or allow worker entry into treated areas during the restricted entry interval (REI) of 4 hours.

PPE required for early entry to treated areas that is permitted under the Worker Protection Standard and that involves contact with anything that has been treated, such as plants, soil, or water, are: coveralls, shoes plus socks, and chemical resistant gloves made of any waterproof material.

Non-Agricultural Use Requirements

The requirements in this box apply to uses of this product that are NOT within the scope of the Worker Protection Standard for agricultural pesticides (40 CFR Part 170). The WPS applies when this product is used to produce agricultural plants on farms, forests, nurseries or greenhouses.

Keep people and pets off treated areas until spray solution has dried.

4.0 STORAGE AND DISPOSAL

Proper pesticide storage and disposal are essential to protect against exposure to people and the environment due to leaks and spills, excess product or waste, and vandalism. Do not allow this product to contaminate water, foodstuffs, feed or seed by storage and disposal.

PESTICIDE STORAGE: STORE ABOVE 5°F (-15°C) TO KEEP PRODUCT FROM CRYSTALLIZING. Crystals will settle to the bottom. If allowed to crystallize, place in a warm room 68°F (20°C) for several days to redissolve and roll or shake container or recirculate in mini-bulk containers to mix well before using. Store pesticides away from food, pet food, feed, seed, fertilizers, and veterinary supplies. Keep container closed to prevent spills and contamination.

PESTICIDE DISPOSAL: To avoid wastes, use all material in this container, including rinsate, by application according to label directions. If wastes cannot be avoided, offer remaining product to a waste disposal facility or pesticide disposal program. Such programs are often run by state or local governments or by industry. All disposal must be in accordance with applicable federal, state and local regulations and procedures.

CONTAINER HANDLING AND DISPOSAL: See container label for container handling and disposal instructions and refilling limitations.

5.0 PRODUCT INFORMATION

Product Description: This product is a postemergent, systemic herbicide with no residual soil activity. It gives broad-spectrum control of many annual weeds, perennial weeds, woody brush and trees. It is formulated as a water-soluble liquid and may be applied through standard equipment after dilution and mixing with water or other carriers according to label instructions.

Time to Symptoms: This product moves through the plant from the point of foliage contact to and into the root system. Visible effects are a gradual wilting and yellowing of the plant which advances to complete browning of above-ground growth and deterioration of underground plant parts. Effects are visible on most annual weeds within 2 to 4 days, but on most perennial weeds may not occur for 7 days or more. Extremely cool or cloudy weather following treatment may slow activity of this product and delay development of visual symptoms.

Stage of Weeds: Annual weeds are easiest to control when they are small. Best control of most perennial weeds is obtained when treatment is made at late growth stages approaching maturity. See the **WEEDS CONTROLLED** section of this label for specific weed rates.

Always use the higher product application rate in the range when weed growth is heavy or dense, or when weeds are growing in an undisturbed (non-cultivated) area. Reduced weed control may result from treating weeds with disease or insect damage, weeds heavily covered with dust, or weeds under poor growing conditions.

Mode of Action in Plants: The active ingredient in this product inhibits production of an enzyme in plants and microorganisms that is essential to formation of specific amino acids.

Cultural Considerations: Reduced control could result when applications are made to annual or perennial weeds that have been mowed, grazed or cut, and have not been allowed to regrow to the specified stage for treatment.

Rainfastness: Heavy rainfall soon after application may wash this product off of the foliage and a repeat application may be required for adequate weed control.

Spray Coverage: For best results, spray coverage should be uniform and complete. Do not spray foliage to the point of run-off.

No Soil Activity: Weeds must be emerged at the time of application to be controlled by this product. Weeds germinating from seed after application will not be controlled. Unemerged plants arising from unattached underground rhizomes or rootstocks of perennials will not be affected by the herbicide and will continue to grow.

Maximum Application Rates: The maximum application or use rates stated throughout this label are given in units of volume (fluid ounces or quarts) of this product per acre. However, the maximum allowed application rates apply to this product combined with the use of any and all other herbicides containing the active ingredient glyphosate, whether applied separately or as tank mixtures, on a basis of total pounds of glyphosate (acid equivalents) per acre. If more than one glyphosate-containing product is applied to the same site within the same year, you must ensure that the total use of glyphosate (pounds acid equivalents) does not exceed the maximum allowed. The combined total of all treatments must not exceed 8 quarts of this product (8 pounds of glyphosate acid) per acre per year. See the **INGREDIENTS** section of this label for necessary product information.

ATTENTION

AVOID CONTACT OF HERBICIDE WITH FOLIAGE, STEMS, EXPOSED NON-WOODY ROOTS OR FRUIT OF CROPS, DESIRABLE PLANTS AND TREES, BECAUSE SEVERE INJURY OR DESTRUCTION MAY RESULT.

AVOID DRIFT. EXTREME CARE MUST BE USED WHEN APPLYING THIS PRODUCT TO PREVENT INJURY TO DESIRABLE PLANTS AND CROPS.

Do not allow the herbicide solution to mist, drip, drift or splash onto desirable vegetation since minute quantities of this product can cause severe damage or destruction to the crop, plants or other areas on which treatment was not intended. The likelihood of injury occurring from the use of this product increases when winds are gusty, as wind velocity increases, when wind direction is constantly changing or when there are other meteorological conditions that favor spray drift. When spraying, avoid combinations of pressure and nozzle type that will result in splatter or fine particles (mist) that are likely to drift. AVOID APPLYING AT EXCESSIVE SPEED OR PRESSURE.

NOTE: Use of this product in any manner not consistent with this label may result in injury to persons, animals or crops, or other unintended consequences.

5.1 Weed Resistance Management

GROUP	9	HERBICIDE
-------	---	-----------

Glyphosate, the active ingredient in this product, is a Group 9 herbicide based on the mode of action classification system of the Weed Science Society of America. Any weed population may contain plants naturally resistant to Group 9 herbicides. Weed species resistant to Group 9 herbicides may be effectively managed utilizing another herbicide from a different Group or using other cultural or mechanical practices.

To minimize the occurrence of glyphosate-resistant biotypes observe the following general weed management recommendations:

- Scout your application site before and after herbicide applications.
- Control weeds early when they are relatively small.
- Incorporate other herbicides and cultural or mechanical practices as part of your weed control system where appropriate.
- Use the labeled rate for the most difficult to control weed in the site. Avoid tank-mixtures with other herbicides that reduce this product's efficacy through antagonism or with tank mixtures that encourage rates of this product below those specified on this label.
- Control weed escapes and prevent weeds from setting seeds.
- Clean equipment before moving from site to site to minimize spread of weed seed.
- Use new commercial seed as free of weed seed as possible.
- Report any incidence of repeated non-performance of this product on a particular weed to your Monsanto representative, local retailer, or county extension agent.

5.2 Management of Glyphosate Resistant Weed Biotypes

NOTE: Appropriate testing is critical in order to confirm weed resistance to glyphosate. Contact your Monsanto representative to determine if resistance has been confirmed to any particular weed biotype in your area. Directions for the control of biotypes confirmed to be resistant to glyphosate are made available on separately published supplemental labeling or Fact Sheets for this product and may be obtained from your local retailer or Monsanto representative.

Since the occurrence of new glyphosate resistant weeds cannot be determined until after product use and scientific confirmation, Monsanto Company is not responsible for any losses that may result from the failure of this product to control glyphosate-resistant weed biotypes.

The following good weed management practices are recommended to reduce the spread of confirmed glyphosate resistant biotypes:

- If a naturally occurring resistant biotype is present at your site, this product may be tank-mixed or applied sequentially with an appropriately labeled herbicide with a different mode of action to achieve control.

- Cultural and mechanical control practices may also be used as appropriate.
- Scout treated sites after herbicide applications and control escapes of resistant biotypes before they set seed.
- Thoroughly clean equipment before leaving sites known to contain resistant biotypes.

6.0 MIXING

Spray solutions of this product can be mixed, stored and applied using only clean stainless steel, fiberglass, plastic or plastic-lined steel containers.

DO NOT MIX, STORE OR APPLY THIS PRODUCT OR SPRAY SOLUTIONS OF THIS PRODUCT IN GALVANIZED STEEL OR UNLINED STEEL (EXCEPT STAINLESS STEEL) CONTAINERS OR SPRAY TANKS.

Use caution to avoid siphoning back into the carrier source. Use approved anti-back-siphoning devices where required by state or local regulations.

Clean sprayer parts promptly after using this product by thoroughly flushing with water.

NOTE: REDUCED PRODUCT PERFORMANCE CAN OCCUR IF WATER CONTAINING SOIL SEDIMENT IS USED AS CARRIER OR WATER THAT IS VISIBLY MUDDY OR MURKY FROM PONDS AND DITCHES.

6.1 Mixing with Water

This product mixes readily with water. Mix spray solutions of this product as follows: Fill the mixing or spray tank with the required amount of clean water. Add the labeled amount of this product near the end of the filling process and mix gently (well). During mixing and application, foaming of the spray solution may occur. To prevent or minimize foam, avoid the use of mechanical agitators, terminate by-pass and return lines at the bottom of the tank and, if needed, use an approved anti-foam or defoaming agent.

6.2 Tank Mixtures

This product does not provide residual weed control. This product can be tank-mixed with other herbicides to provide residual weed control, a broader weed control spectrum or an alternate mode of action. Always read and follow label directions for all products in the tank mixture.

When this product is tank-mixed with other products, refer to these product labels for approved sites and application rates. Read and carefully observe the cautionary statements and all other information appearing on the labels of all herbicides used. Use according to the most restrictive precautionary statements for each product in the mixture. Any labeled rate of this product may be used in a tank mix.

When this label lists a tank mixture with a generic active ingredient such as diuron, 2,4-D or dicamba, the user is responsible for ensuring the mixture product label allows the specific application.

Buyer and all users are responsible for all loss or damage in connection with the use or handling of mixtures of this product with herbicides or other materials that are not expressly listed in this label. Mixing this product with herbicides or other materials not specified on this label may result in reduced performance.

This product provides control of the emerged weeds listed on this label. When applied as a tank mixture, the following herbicides will provide preemergence and/or postemergence control of the weeds listed in the individual product labels.

This product can be tank-mixed with the following products. Any labeled rate of this product can be used in a tank mixture with these products. User is responsible for ensuring that the specific product is registered for use on the target site. Refer to these product labels for approved application sites and application rates. Read and carefully observe the cautionary statements and all other information on the labels of all the herbicides used. Use according to the most restrictive precautionary statements for each product in the mixture.

Tank-mix Products

Arsenal	Krovar I DF + 2,4-D
Banvel	Krovar I DF + Garlon 3A
2,4-D	Krovar I DF + Garlon 4
Garlon 3A	Oust XP
Garlon 4	Oust XP + 2,4-D
diuron	Oust XP + Garlon 3A
diuron + 2,4-D	Oust XP + Garlon 4
diuron + Garlon 3A	Ronstar
diuron + Garlon 4	Spike 80W
Hyvar X	Spike 80W + 2,4-D
Hyvar X + 2,4-D	Spike 80W + Garlon 3A
Hyvar X + Garlon 3A	Spike 80W + Garlon 4
Hyvar X + Garlon 4	Surflan
Krovar I DF	

When used in combination as recommended by Monsanto Company, the liability of Monsanto shall in no manner extend to any damage, loss or injury not solely and directly caused by the inclusion of the Monsanto product in such combination use.

6.3 Tank Mixing Procedure

When tank mixing, read and carefully observe label directions, cautionary statements and all information on the labels of all products used. Add the tank-mix product to the tank as directed by the label. Maintain agitation and add the specified amount of this product.

Maintain good agitation at all times during the mixing process. Ensure that the tank-mix products are well mixed with the spray solution before adding this product.

Mix only the quantity of spray solution that can be used during the same day. Tank mixtures allowed to stand overnight may result in reduced weed control.

Maintain good agitation at all times until the contents of the tank are sprayed. If the spray mixture is allowed to settle, thorough agitation is required to resuspend the mixture before spraying is resumed.

Keep by-pass line on or near the bottom of the tank to minimize foaming. Screen size in nozzle or line strainers should be no finer than 50 mesh.

Always predetermine the compatibility of labeled tank mixtures of this product with water carrier by mixing small proportional quantities in advance. Ensure that the specific tank mixture product is registered for application at the desired site.

6.4 Mixing Percent Solutions

Prepare the desired volume of spray solution by mixing the amount of this product in water as shown in the following table:

Spray Solution

Desired Volume	Amount of Roundup Custom for Aquatic and Terrestrial Use					
	0.5%	0.75%	1%	1.5%	4%	8%
1 gal	2/3 oz	1 oz	1.3 oz	2 oz	5 oz	10 oz
25 gal	1 pt	1.5 pt	1 qt	1.5 qt	4 qt	2 gal
100 gal	2 qt	3 qt	1 gal	1.5 gal	4 gal	8 gal

2 tablespoons = 1 fluid ounce

For use in backpack, knapsack or pump-up sprayers, it is suggested that the specified amount of this product be mixed with water in a larger container. Fill sprayer with the mixed solution.

6.5 Surfactant

This product requires the use of a nonionic surfactant unless otherwise specified. When using this product, unless otherwise specified, mix 2 or more quarts of a nonionic surfactant per 100 gallons of spray solution. Increasing the rate of surfactant may enhance performance. Examples of when to use the higher surfactant rate include, but are not limited to: hard to control woody brush, trees and vines, high water volumes, adverse environmental conditions, tough to control weeds, weeds under stress, surfactants with less than 70 percent active ingredient, tank mixes, etc.

Always read and follow the manufacturer's surfactant label for best results. Carefully observe all cautionary statements and other information appearing in the surfactant label.

6.6 Colorants or Dyes

Approved colorants or marking dyes may be added to this product. At lower rates or dilution, colorants or dyes used in spray solutions of this product may reduce performance. Use colorants or dyes according to the manufacturer's instructions.

6.7 Drift Reduction Additives

Drift reduction additives can be used with all equipment types, except wiper applicators and sponge bars. When a drift reduction additive is used, read and carefully observe precautionary statements and all other information appearing on the additive label. The use of drift reduction additives can affect spray coverage which may result in reduced performance.

7.0 APPLICATION EQUIPMENT AND TECHNIQUES

Do not apply this product through any type of irrigation system.

APPLY THESE SPRAY SOLUTIONS IN PROPERLY MAINTAINED AND CALIBRATED EQUIPMENT CAPABLE OF DELIVERING DESIRED VOLUMES.

SPRAY DRIFT MANAGEMENT

AVOID DRIFT. EXTREME CARE MUST BE USED WHEN APPLYING THIS PRODUCT TO PREVENT INJURY TO DESIRABLE PLANTS AND CROPS.

Do not allow the herbicide solution to mist, drip, drift or splash onto desirable vegetation since minute quantities of this product can cause severe damage or destruction to the crop, plants or other areas on which treatment was not intended.

Avoiding spray drift at the application site is the responsibility of the applicator. The interaction of many equipment- and weather-related factors determines the potential for spray drift. The applicator and/or the grower are responsible for considering all these factors when making decisions.

7.1 Aerial Equipment

DO NOT APPLY THIS PRODUCT USING AERIAL SPRAY EQUIPMENT EXCEPT UNDER CONDITIONS AS SPECIFIED WITHIN THIS LABEL.

FOR AERIAL APPLICATION IN CALIFORNIA, OR SPECIFIC COUNTIES THEREIN, REFER TO THE FEDERAL SUPPLEMENTAL LABELING FOR AERIAL APPLICATIONS OF THIS PRODUCT IN THAT STATE OR COUNTY FOR SPECIFIC INSTRUCTIONS, RESTRICTIONS AND REQUIREMENTS.

This product, tank-mixed with dicamba, may not be applied by air in California. Only 2,4-D amine formulations may be applied by air in California.

Use the labeled rates of this herbicide in 3 to 25 gallons of water per acre.

TO PREVENT INJURY TO ADJACENT DESIRABLE VEGETATION, APPROPRIATE BUFFER ZONES MUST BE MAINTAINED.

Avoid direct application to any body of water. Drift control reduction additives may be used. When a drift control reduction additive is used, read and carefully observe the cautionary statements and all other information appearing on the additive label.

Ensure uniform application. To avoid streaked, uneven or overlapped application, use appropriate marking devices.

Aircraft Maintenance

PROLONGED EXPOSURE OF THIS PRODUCT TO UNCOATED STEEL SURFACES MAY RESULT IN CORROSION AND POSSIBLE FAILURE OF THE PART. The maintenance of an organic coating (paint) which meets aerospace specification MIL-C-38413 may prevent corrosion. To prevent corrosion of exposed parts, thoroughly wash aircraft after each day of spraying to remove residues of this product accumulated during spraying or from spills. Landing gear is most susceptible.

AERIAL SPRAY DRIFT MANAGEMENT

The following drift management requirements must be followed to avoid off-target drift movement from aerial applications to agricultural field crops. These requirements do not apply to forestry applications or to public health uses.

1. The distance of the outermost nozzles on the boom must not exceed 3/4 the length of the wingspan or rotor.
2. Nozzles must always point backward parallel with the air stream and never be pointed downwards more than 45 degrees. Where states have more stringent regulations, they should be observed.

Importance of Droplet Size

The most effective way to reduce drift potential is to apply large droplets. The best drift management strategy is to apply the largest droplets that provide sufficient coverage and control. Applying larger droplets reduces drift potential, but will not prevent drift if applications are made improperly, or under unfavorable environmental conditions (see the Wind, Temperature and Humidity, and Temperature Inversions sections of this label).

Controlling Droplet Size

Volume: Use high flow rate nozzles to apply the highest practical spray volume. Nozzles with the higher rated flows produce larger droplets.

Pressure: Use the lower spray pressures recommended for the nozzle. Higher pressure reduces droplet size and does not improve canopy penetration. When higher flow rates are needed, use higher flow rate nozzles instead of increasing pressure.

Number of nozzles: Use the minimum number of nozzles that provide uniform coverage.

Nozzle orientation: Orienting nozzles so that the spray is released backwards, parallel to the air stream, will produce larger droplets than other orientations. Significant deflection from the horizontal will reduce droplet size and increase drift potential.

Nozzle type: Use a nozzle type that is designed for the intended application. With most nozzle types, narrower spray angles produce larger droplets. Consider using low-drift nozzles. Solid stream nozzles oriented straight back produce larger droplets than other nozzle types.

Boom length: For some use patterns, reducing the effective boom length to less than 3/4 of the wingspan or rotor length may further reduce drift without reducing swath width.

Application height: Applications must not be made at a height greater than 10 feet above the top of the largest plants unless a greater height is required for aircraft safety. Making applications at the lowest height that is safe reduces the exposure of the droplets to evaporation and wind.

Swath Adjustment

When applications are made with a crosswind, the swath will be displaced downwind. Therefore, on the up and downwind edges of the field, the applicator must compensate for this displacement by adjusting the path of the aircraft upwind. Swath adjustment distance should increase, with increasing drift potential (higher wind, smaller droplets, etc.).

Wind

Drift potential is lowest between wind speeds of 2 to 10 miles per hour. However, many factors, including droplet size and equipment type determine drift potential at any given speed. Application should be avoided below 2 miles per hour due to variable wind direction and high inversion potential. **NOTE:** Local terrain can influence wind patterns. Every applicator should be familiar with local wind patterns and how they affect drift.

Temperature and Humidity

Set up equipment to produce larger droplets when making applications in low relative humidity to compensate for evaporation. Droplet evaporation is most severe when conditions are both hot and dry.

Temperature Inversions

Applications must not occur during a temperature inversion because drift potential is high. Temperature inversions restrict vertical air mixing, which causes small suspended droplets to remain in a concentrated cloud. This cloud can move in unpredictable directions due to the light variable winds common during inversions. Temperature inversions are characterized by increasing temperatures with altitude and are common on nights with limited cloud cover and light to no wind. They begin to form as the sun sets and often continue into the morning. Their presence can be indicated by ground fog; however, if fog is not present, inversions can also be identified by the movement of smoke from a ground source or an aircraft smoke generator. Smoke that layers and moves laterally in a concentrated cloud (under low wind conditions) indicates an inversion, while smoke that moves upward and rapidly dissipates indicates good vertical air mixing.

Sensitive Areas

This product must only be applied when the potential for drift to adjacent sensitive areas (e.g., residential areas, bodies of water, known habitat for threatened or endangered species, non-target crops) is minimal (e.g., when wind is blowing away from the sensitive areas).

7.2 Ground Broadcast Equipment

For broadcast ground applications, unless otherwise specified in this label or in separate supplemental labeling or Fact Sheets published by Monsanto, use this product at the rate of 1.5 to 3 pints per acre for annual weeds, 3 to 7.5 pints per acre for perennial weeds and 3 to 7.5 pints per acre for woody brush and trees. When used according to label directions this product will give control or partial control of herbaceous weeds, woody brush and trees listed in the **WEEDS CONTROLLED** section of this label.

Use the labeled rates of this product in 3 to 40 gallons of water per acre as a broadcast spray unless otherwise specified in this label or in separate supplemental labeling or Fact Sheets published by Monsanto. As weed density increases, the spray volume should be increased toward the upper end of the specified range to ensure complete coverage. Carefully select proper nozzles to avoid spraying a fine mist. For best results with ground application equipment, use flat-fan nozzles. Check spray pattern for even distribution of spray droplets.

7.3 Hand-Held Equipment

Apply to foliage of vegetation to be controlled. For applications made on a spray-to-wet basis, spray coverage should be uniform and complete. Do not spray to the point of runoff. Use coarse sprays only.

For control of weeds listed in the **Annual Weeds** section of **WEEDS CONTROLLED**, apply a 0.5-percent solution of this product to weeds less than 6 inches in height or runner length. For annual weeds over 6 inches tall, or unless otherwise specified, use a 1-percent solution. Apply prior to seedhead formation in grass or bud formation in broadleaf weeds.

For best results, use a 1.5-percent solution on harder-to-control perennials, woody vines, brush and trees. Make applications to perennials after seedhead emergence in grasses or bud formation in broadleaf weeds, woody brush and trees for best results.

For low-volume directed spray applications, use a 4- to 8-percent solution of this product for control or partial control of annual weeds, perennial weeds, or woody brush and trees. Spray coverage should be uniform with at least 50 to 75 percent of the foliage contacted. Coverage of the top one half of the plant is important for best results. If a straight stream nozzle is used, start the application at the top of the targeted vegetation and spray from top to bottom in a lateral zig-zag motion. For flat-fan and cone nozzles and with hand-directed mist blowers, mist the application over the foliage of the targeted vegetation. To ensure adequate spray coverage, spray both sides of large or tall woody brush and trees, when foliage is thick and dense, or where there are multiple sprouts. For best results, apply to actively growing woody brush and trees after full leaf expansion and before fall color and leaf drop.

Unless otherwise specified, use the rates listed in the following table for various methods of foliar application using high-volume, backpack, knapsack and similar types of hand-held equipment. When used according to label directions this product will give control or partial control of herbaceous weeds, woody brush and trees listed in the **WEEDS CONTROLLED** section of this label.

APPLICATION RATES

APPLICATION		SPRAY VOLUME Gallons/Acre
SPRAY-TO-WET		
Handgun or Backpack	0.5 to 1.5% by volume	spray-to-wet*
LOW-VOLUME DIRECTED SPRAY		
Backpack	4 to 8% by volume	15 to 25**
Modified High-volume	1.5 to 3% by volume	40 to 60**

* For applications made on a spray-to-wet basis, spray coverage should be uniform and complete. Do not spray to the point of runoff.

**Low-volume directed applications with backpacks work best when treating weeds and brush less than 10 feet tall. For taller weeds and brush, high-volume handguns can be modified by reducing nozzle size and spray pressure to produce a low-volume directed spray.

7.4 Selective Equipment

This product can be applied through recirculating spray systems, shielded applicators, hooded sprayers, wiper applicators or sponge bars, after dilution and thorough mixing with water, to listed weeds growing in any aquatic or non-agricultural crop site specified on this label.

A recirculating spray system directs the spray solution onto weeds growing above desirable vegetation, while spray solution not intercepted by weeds is collected and returned to the spray tank for reuse.

AVOID CONTACT OF THIS HERBICIDE WITH DESIRABLE VEGETATION, AS SERIOUS INJURY OR DEATH TO DESIRABLE VEGETATION IS LIKELY TO OCCUR.

Applicators used above desired vegetation should be adjusted so that the lowest spray stream or wiper contact point is at least 2 inches above the desirable vegetation. Droplets, mist, foam or splatter of the herbicide solution settling on desirable vegetation is likely to result in discoloration, stunting or destruction.

Better results may be obtained when more of the weed is exposed to the herbicide solution. Weeds not contacted by the herbicide solution will not be affected. This may occur in dense clumps, severe infestations or when the height of the weeds varies so that not all weeds are contacted. In these instances, repeat treatment may be necessary.

Shielded and Hooded Applicators

A shielded or hooded applicator directs the herbicide solution onto weeds, while shielding desirable vegetation from the herbicide. Use nozzles that provide uniform coverage within the treated area. Keep shields on these sprayers adjusted to protect desirable vegetation. USE EXTREME CARE TO AVOID CONTACT OF HERBICIDE WITH DESIRABLE VEGETATION.

Wiper Applicators and Sponge Bars

Wiper applicators are devices that physically wipe this product directly onto the weed.

Equipment must be designed, maintained and operated to prevent the herbicide solution from contacting desirable vegetation. Operate this equipment at ground speeds no greater than 5 miles per hour. Performance may be improved by reducing speed in areas of heavy weed infestations to ensure adequate wiper saturation. Better results may be obtained if 2 applications are made in opposite directions.

Avoid leakage or dripping onto desirable vegetation. Adjust height of applicator to ensure adequate contact with weeds. Keep wiping surfaces clean. Be aware that, on sloping ground, the herbicide solution may migrate, causing dripping on the lower end and drying of the wicks on the upper end of a wiper applicator.

Do not use wiper equipment when weeds are wet.

Mix only the amount of solution to be used during a 1-day period, as reduced activity may result from the use of leftover solutions. Clean wiper parts immediately after using this product by thoroughly flushing with water.

Nonionic surfactant at a rate of 10 percent by volume of total herbicide solution is recommended with all wiper applications.

For Rope or Sponge Wick Applicators—Solutions ranging from 33 to 75 percent of this product in water may be used.

For Panel Applicators—Solutions ranging from 33 to 100 percent of this product in water may be used in panel wiper applicators.

7.5 Injection Systems

This product can be used in aerial or ground injection spray systems. It may be used as a liquid concentrate or diluted prior to injecting into the spray stream. Do not mix this product with the undiluted concentrate of other products when using injection systems unless specifically recommended.

7.6 CDA Equipment

The rate of this product applied per acre by controlled droplet application (CDA) equipment must not be less than the amount in this label when applied by conventional broadcast equipment. For vehicle-mounted CDA equipment, apply 2 to 15 gallons of water per acre.

For the control of annual weeds with hand-held CDA units — Apply a 15-percent solution of this product (19.25 oz of product per gallon) at a flow rate of 2 fluid ounces per minute and a walking speed of 1.5 miles per hour (1 quart per acre). For the control of perennial weeds, apply a 15- to 30-percent solution of this product at a flow rate of 2 fluid ounces per minute and a walking speed of 0.75 mile per hour (2 to 4 quarts per acre).

CDA equipment produces a spray pattern that is not easily visible. Extreme care must be exercised to avoid spray or drift contacting the foliage or any other tissue of desirable vegetation, as damage or destruction is likely to result.

8.0 SITE AND USE INSTRUCTIONS

This product can be used to control weeds, woody brush and trees in aquatic sites, non-agricultural crop sites and crop sites listed on this label.

Non-agricultural crop sites include airports, apartment complexes, commercial sites, ditch banks, dry ditches, dry canals, fence rows, forestry sites, golf courses, habitat restoration and management areas, industrial sites, lumber yards, manufacturing sites, municipal sites, natural areas, office complexes, public areas, parks, parking

areas, pastures, petroleum tank farms and pumping installations, railroads, rangeland, recreational areas, residential areas, roadsides, schools, storage areas, substations, utility rights-of-way, utility sites, warehouse areas, and wildlife management areas.

Crop sites include citrus, sugarcane, turf, sod and vegetable fallow.

Unless otherwise specified on this label or in separate supplemental labeling or Fact Sheets published by Monsanto, applications may be made to control any weeds listed in the **Annual Weeds, Perennial Weeds and Woody Brush And Trees** rate tables. Refer also to the **Selective Equipment** section.

8.1 Aquatic Sites

This product can be applied to emerged weeds in all bodies of fresh and brackish water which may be flowing, non-flowing or transient. This includes lakes, rivers, streams, ponds, estuaries, rice levees, seeps, irrigation and drainage ditches, canals, reservoirs, wastewater treatment facilities, wildlife habitat restoration and management areas.

If aquatic sites are present in the area and are part of the intended treatment, read and observe the following directions:

This product does not control plants which are completely submerged or have a majority of their foliage under water.

There is no restriction on the use of treated water for irrigation, recreation or domestic purposes.

Consult your local state fish and game agency and water control authorities before applying this product to public water. Permits may be required to treat such water.

NOTE: Do not apply this product **directly to water** within 0.5 mile upstream of an active potable water intake in flowing water (i.e., river, stream, etc.) or within 0.5 mile of an active potable water intake in a standing body of water such as lake, pond or reservoir. To make aquatic applications around and within 0.5 mile of active potable water intakes, the water intake must be turned off for a minimum period of 48 hours after the application. The water intake may be turned on prior to 48 hours if the glyphosate level in the intake water is below 0.7 parts per million as determined by laboratory analysis. These aquatic applications may be made **ONLY** in those cases where there are alternative water sources or holding ponds which would permit the turning off of an active potable water intake for a minimum period of 48 hours after the applications. This restriction does **NOT** apply to intermittent inadvertent overspray of water in terrestrial use sites.

For treatments after drawdown of water or in dry ditches, allow 7 or more days after treatment before reintroduction of water to achieve maximum weed control. Apply this product within 1 day after drawdown to ensure application to actively growing weeds.

Floating mats of vegetation may require retreatment. Avoid wash-off of sprayed foliage by spray boat or recreational boat backwash or by rainfall within 6 hours of application. Do not retreat within 24 hours following the initial treatment.

Applications made to moving bodies of water must be made while traveling upstream to prevent concentration of this herbicide in water. When making any bankside applications, do not overlap more than 1 foot into open water. Do not spray in bodies of water where weeds do not exist. The maximum application rate of 7.5 pints per acre must not be exceeded in any single broadcast application that is being made over water except as follows, where any labeled rate may be applied:

- Stream crossings in utility rights-of-way.
- Where applications will result in less than 20 percent of the total water area being treated.

When emerged infestations require treatment of the total surface area of impounded water, treating the area in strips may avoid oxygen depletion due to decaying vegetation. Oxygen depletion may result in fish kill.

For Control of Cordgrass (*Spartina* spp.)

The presence of debris and silt on the surface of cordgrass plants will reduce product performance. It may be necessary to wash targeted plants prior to application to improve herbicide uptake. Where cordgrass has been cut or mowed prior to application, allow significant regrowth before application to ensure adequate interception and uptake of the herbicide solution. Rainfall within 2 hours or immersion within 4 hours after application may reduce effectiveness.

Prior to application, survey the areas to be treated to determine if shellfish beds exist within the intended treatment area. Wait either until shellfish have been harvested before application is made or do not harvest shellfish for 14 days following treatment.

Add 1 to 2 quarts or more of nonionic surfactant or other adjuvant approved for use on aquatic sites and compatible with this product per 100 gallons of spray solution for broadcast applications (ground or air) and when using optical sensing application equipment.

Do not apply this product through any type of irrigation system.

APPLICATION

Under ideal application conditions, that is, where silt and debris are not present on plant surfaces, good spray coverage is achievable, target plants are actively growing and labeled rates and application volumes are used, allow at least 4 hours drying time before plants are covered by tidewater. Where one or more of these conditions are not met, schedule applications to allow at least 5 hours drying time before plants are covered by tidewater. Do not apply when wind speed at the application site exceed 10 miles per hour.

Broadcast Application (Ground): Apply 2 to 8 quarts of this herbicide in 5 to 100 gallons of spray solution per acre. For best results, complete coverage of cordgrass clumps is required.

Broadcast Application (Ground/Optical Sensing Application Equipment): Apply 2 to 8 quarts of this product in 5 to 100 gallons of spray solution per acre using equipment designed and calibrated to deliver spray solution only when cordgrass plants are present and detected by optical sensors. For best results, complete coverage of cordgrass clumps is required.

Hand-Held Backpack or High-volume Equipment: Apply a 5 to 8 percent solution of this product. Ensure that complete coverage of cordgrass clumps is achieved. Do not spray to the point of runoff.

Broadcast Application (Air): Apply 2 to 8 quarts of this product in 5 to 10 gallons of spray solution per acre. Maintain at least a 50-foot buffer between commercial shellfish beds and treated areas. The potential for spray drift is dependent upon weather- and equipment-related factors. The applicator must be familiar with local wind patterns and monitor and record temperature and wind speed prior to and periodically during application. Schedule application in order to allow at least 5 hours before treated plants are covered by tidewater.

For Foliar and Broadcast Treatment of Japanese Knotweed

For control of Japanese knotweed (*Polygonum cuspidatum*), this product may be applied as a 2.0% v/v spray-to-wet solution with 0.5 to 2.0% v/v of a nonionic surfactant containing at least 70 percent active ingredient. Ensure thorough coverage when using spray-to-wet treatments using hand-held equipment.

For broadcast applications, apply 3 quarts of this product with an aquatic approved surfactant system containing 0.1% v/v nonionic organosilicone and 0.25% v/v nonionic spreader sticker surfactant in 3 to 40 gallons per acre as a broadcast treatment.

Allow at least 3 days after application before disturbing treated vegetation. This product does not control plants which are completely submerged or have a majority of their foliage under water.

For Foliar and Broadcast Treatment of Oriental Bittersweet

For control of Oriental bittersweet (*Celastrus orbiculatus*), this product may be applied as a 2.0% v/v spray-to-wet solution with 0.5 to 2.0% v/v of a nonionic surfactant containing at least 70 percent active ingredient. Ensure thorough coverage when using spray-to-wet treatments using hand-held equipment.

For broadcast application, apply 2.25 quarts of this product with an aquatic approved surfactant system containing 0.1% v/v nonionic organosilicone and 0.25% v/v nonionic spreader sticker surfactant in 3 to 40 gallons per acre as a broadcast treatment.

Allow at least 3 days after application before disturbing treated vegetation. This product does not control plants which are completely submerged or have a majority of their foliage under water.

Tank Mixtures

Tank mixtures of this product plus 2,4-D amine may be used to increase the spectrum of vegetation controlled in aquatic sites. Use 1.5 to 2 pints of this product plus 1 to 2 quarts of 2,4-D amine (4 pounds active ingredient per gallon, labeled for aquatic sites) for control of annual weeds. Use 3 to 7.5 pints of this product plus 2 to 4 quarts of 2,4-D amine (4 pounds active ingredient per gallon, labeled for aquatic sites) for control or partial control of perennial weeds, woody brush and trees.

When tank mixing, read and carefully observe the label claims, cautionary statements and all information on the labels of all products used. Use according to the most restrictive precautionary statements for each product in the mixture. Mix in the following sequence: Fill sprayer tank one-half full with water, add Roundup Custom for Aquatic and Terrestrial Use, then 2,4-D amine and finally surfactant. Fill sprayer tank to final volume of water.

NOTE: DO NOT MIX ROUNDUP CUSTOM FOR AQUATIC AND TERRESTRIAL USE AND 2,4-D AMINE CONCENTRATES WITHOUT WATER CARRIER. DO NOT MIX ROUNDUP CUSTOM FOR AQUATIC AND TERRESTRIAL USE AND 2,4-D AMINE IN BYPASS INJECTOR-TYPE SPRAY EQUIPMENT.

8.2 Cut Stump

Cut stump treatments may be made on any site listed on this label. This product will control many types of woody brush and tree species. Apply this product using suitable equipment to ensure coverage of the entire cambium. Cut trees or resprouts close to the soil surface. Apply a 50- to 100-percent solution of this product to the freshly-cut surface **immediately after** cutting. Delays in application may result in reduced performance. For best results, applications should be made during periods of active growth and full leaf expansion.

For control of *Ailanthus altissima* (Tree-of-heaven) make a cut stump treatment according to the directions in this section using a spray mixture of 50% Roundup Custom for Aquatic and Terrestrial Use and 10% Arsenal.

DO NOT MAKE CUT STUMP APPLICATIONS WHEN THE ROOTS OF DESIRABLE WOODY BRUSH OR TREES MAY BE GRAFTED TO THE ROOTS OF THE CUT STUMP. Some sprouts, stems, or trees may share the same root system. Adjacent trees having a similar age, height and spacing may signal shared roots. Whether grafted or shared, injury is likely to occur to non-treated stems/trees when one or more trees sharing common roots are treated.

8.3 Conifer and Herbaceous Release Sites

This product can be used for conifer release as a broadcast spray for control, partial control or suppression of herbaceous weeds and hardwoods listed in the **WEEDS CONTROLLED** section of this label. Use only where conifers have been established for more than one year unless otherwise stated below. This product can be applied as a

directed spray or by using selective equipment in forestry hardwood and conifer sites, including Christmas tree plantations and silvicultural nurseries.

Use a nonionic surfactant that is labeled for use in over-the-top conifer release applications. Refer to the surfactant manufacturer's label for surfactant use rates and other precautionary statements. Use of this product without a surfactant will result in reduced herbicide performance.

APPLICATION MUST BE MADE AFTER FORMATION OF FINAL CONIFER RESTING BUDS IN THE FALL OR PRIOR TO INITIAL BUD SWELLING IN THE SPRING.

Injury may occur to conifers treated for release, especially where spray patterns overlap or the higher rates are applied. Damage can be accentuated if applications are made when conifers are actively growing, or are under stress from drought, flood water, improper planting, insects, animal damage or diseases.

For release of the following conifer species outside the Southeastern United States: Douglas fir, Fir, Hemlock, Pines*, California Redwood, Spruce

*Includes all species except loblolly pine, longleaf pine, shortleaf pine or slash pine.

Use 1.5 to 3 pints of this product per acre as a broadcast spray.

To release Douglas fir, and pine and spruce species at the end of the first growing season (except in California), this product can be used at the lower labeled rates of 1.5 to 2.5 pints per acre. Ensure that the conifers are well hardened off before application. Make sure that the nonionic surfactant has been adequately tested for safety to Douglas fir before use.

For release of Spruce (*Picea spp.*) in Maine, Michigan, Minnesota, New Hampshire and Wisconsin, up to 4.5 pints per acre of this product may be used for the control of difficult woody brush and tree species and application must be made after formation of final conifer resting buds in the fall.

Use of a surfactant is not recommended for release of hemlock species or California redwood. In mix conifer stands injury to these species may result if a surfactant is used.

For release of the following conifer species in the Southeastern United States:

Loblolly pine, Slash pine, Eastern white pine, Virginia pine, Shortleaf pine, Longleaf pine

Apply 2.25 to 3.75 pints of this product per acre as a broadcast spray during late summer or early fall after the pines have hardened off.

For applications made at the end of the first growing season, use 1.5 pints per acre of this product.

TANK MIXTURES: This product can be tank-mixed with the following products for conifer or herbaceous release. When tank mixing, read and carefully observe the label claims, cautionary statements and all information on the labels of all products used. Use according to the most restrictive precautionary statements and label uses for each product in the mixture.

When applied as directed, this product plus listed residual herbicides provides postemergence control of the annual weeds and control or suppression of the perennial weeds listed in this label, and residual control of the weeds listed in the residual herbicide label. Use only on conifer species that are labeled for over-the top sprays for both products.

atrazine
Arsenal Applicator Concentrate
Oust XP

Late Summer and Fall after Resting Bud Formation

For release of jack pine, white pine and white spruce, apply 1.5 to 3 pints of this product plus 1 to 3 ounces of Oust XP per acre. For white pine tank mix a maximum of 1 to 1.5 ounces of Oust XP per acre.

For conifer release of Douglas fir, use 1.5 to 2.25 pints of this product plus 2 to 6 ounces of Arsenal Applicator Concentrate per acre. For conifer release of balsam fir and red spruce, apply 3 pints of this product plus 1 to 2.5 ounces of Arsenal Applicator Concentrate per acre.

Herbaceous Release

For spring and early summer herbaceous release of loblolly pine, Virginia and longleaf pine apply 12 to 18 fluid ounces of this product with 2 to 4 ounces of Oust XP.

For early spring release of Douglas fir, prior to bud swell, apply 1.5 pints of this product plus 4 pounds active ingredient of atrazine per acre. Allow one full growing season before application. Do not add surfactant to this treatment.

8.4 Forestry Site Preparation

Use this product for the control or partial control of woody brush, trees and herbaceous weeds in forestry or for use in preparing or establishing wildlife openings within these sites and maintaining logging roads.

This product can also be used in site preparation prior to planting any tree species, including Christmas trees, eucalyptus, hybrid tree cultivars and silvicultural nursery sites.

For applications using different types of equipment, see **APPLICATION RATES** table in the **HAND-HELD EQUIPMENT** section of this label.

TANK MIXTURES: Tank mixtures of this product can be used to increase the spectrum of vegetation controlled in forestry site preparation. When tank mixing, read and carefully

observe the label claims, cautionary statements and all information on the labels of all products used. Use according to the most restrictive precautionary statements for each product in the mixture.

NOTE: For forestry site preparation, make sure the tank-mix product is approved for use prior to planting the desired species. Observe planting interval restrictions.

Any labeled rate of this product can be used in a tank mix with the following products for forestry site preparation.

Arsenal Applicators Concentrate	Garlon 3A
Chopper	Garlon 4
Chopper GEN2	Oust XP
Escort	

For control of herbaceous weeds, use the lower specified tank mixture rates. For control of dense stands or tough-to-control woody brush and trees, use the higher labeled rates.

Unless otherwise directed on this label or in separately published Monsanto supplemental labeling or Fact Sheet, do not apply this product as an over-the-top broadcast spray for forestry conifer or hardwood release.

8.5 Non-Crop Areas and Industrial Sites

Use in areas including airports, apartment complexes, commercial sites, ditch banks, dry ditches, dry canals, fencerows, forestry sites, golf courses, industrial sites, lumber yards, manufacturing sites, office complexes, parks, parking areas, petroleum tank farms and pumping installations, railroads, recreational areas, residential areas, roadsides, sod or turf seed farms, schools, storage areas, substations, utility sties, warehouse areas, and wildlife management areas.

Weed Control, Trim-and-Edge and Bare Ground

This product can be used in non-agricultural crop areas. It can be applied with any application equipment described in this label. This product can be used to trim-and-edge around objects for spot treatment of unwanted vegetation and to eliminate unwanted weeds growing in established shrub beds or ornamental plantings. This product can be used prior to planting an area to ornamentals, flowers, turfgrass (sod or seed), or prior to laying asphalt or beginning construction projects.

Repeat applications of this product as weeds emerge to maintain bare ground.

TANK MIXTURES: This product can be tank-mixed with the following products.

Arsenal	Garlon 3A	Ronstar 50WP
atrazine*	Garlon 4	simazine*
Barricade 65WG	Goal 2XL	Surflan AS
Certainty®	Krovar I DF	Surflan WDG
Crossbow L	Landmark II	Telar DF
dicamba*	Landmark II MP	Transline
diuron*	Outrider®	Velpar DF
Endurance	Oust XP	Velpar L
Escort XP	Plateau	2,4-D*
Gallery 75DF	Poast	

*User is responsible for ensuring that tank mixtures with products containing this generic active ingredient may be made provided the specific product is registered for this use.

Do not apply dicamba tank mixtures by air in California. Only 2,4-D amine formulations can be applied by air in California.

Brush Control Tank Mixtures

TANK MIXTURES: Tank mixtures of this product can be used to increase the spectrum of control for herbaceous weeds, woody brush and trees. When tank mixing, read and carefully observe the label claims, cautionary statements and all information on the labels of all products used. Use according to the most restrictive precautionary statements for each product in the mixture. Any labeled rate of this product can be used in a tank mix.

For control of herbaceous weeds, use the lower tank mixture rates. For control of dense stands or tough-to-control woody brush and trees, use the higher labeled rates.

NOTE: For side trimming treatments, this product can be used alone or in tank mixture with Garlon 4.

Arsenal	Garlon 3A
Escort XP	Garlon 4

Chemical mowing - Perennials

This product will suppress perennial grasses listed in this section to serve as a substitute for mowing. Use 6 fluid ounces of this product per acre when treating tall fescue, fine fescue, orchardgrass, quackgrass or reed canarygrass covers. Use 5 fluid ounces of this product per acre when treating Kentucky bluegrass. Apply treatments in 10 to 40 gallons of spray solution per acre. Apply after grasses have greened up to at least 75 percent green color in the spring, or 7 to 10 days after mowing when sufficient regrowth has occurred to provide a desirable height for growth regulation.

Use only in areas where some temporary injury or discoloration of perennial grasses can be tolerated.

Chemical mowing - Annuals

For growth suppression of some annual grasses, such as annual ryegrass, wild barley and wild oats growing in coarse turf on roadsides or other industrial areas, apply 3 to 4 fluid ounces of this product in 10 to 40 gallons of spray solution per acre. Applications

should be made when annual grasses are actively growing and before the seedheads are in the boot stage of development. Treatments may cause injury to the desired grasses.

Dormant Turfgrass

Use this product to control or suppress many winter annual weeds and tall fescue for effective release of dormant bermudagrass and bahiagrass turf. Treat only when turf is dormant and prior to spring greenup.

Apply 6 to 48 fluid ounces of this product per acre. Apply the labeled rates in 10 to 40 gallons of water per acre. Use only in areas where bermudagrass or bahiagrass are desirable ground covers and where some temporary injury or discoloration can be tolerated.

Treatments in excess of 12 fluid ounces per acre may result in injury or delayed greenup in highly maintained areas, such as golf courses and lawns. DO NOT apply tank mixtures of this product plus Oust XP or Outrider in highly maintained turfgrass areas. For further uses, refer to the **ROADSIDES** section of this label, which gives rates for dormant bermudagrass and bahiagrass treatments.

Actively Growing Bermudagrass

This product can be used to control or partially control many annual and perennial weeds for effective release of actively growing bermudagrass. DO NOT apply more than 12 fluid ounces of this product per acre in highly maintained turfgrass areas. DO NOT apply tank mixtures of this product plus Oust XP or Outrider in highly maintained turfgrass areas. For further uses, refer to the **ROADSIDES** section of this label, which gives rates for actively growing bermudagrass treatments. Use only in areas where some temporary injury or discoloration can be tolerated.

Turfgrass Renovation, Seed, or Sod Production

This product controls most existing vegetation prior to renovating turfgrass areas or establishing turfgrass grown for seed or sod. For maximum control of existing vegetation, delay planting or sodding to determine if any regrowth from escaped underground plant parts occurs. Where repeat treatments are necessary, sufficient regrowth must be attained prior to application. For warm-season grasses such as bermudagrass, summer or fall applications provide the best control. Where existing vegetation is growing under mowed turfgrass management, apply this product after omitting at least one regular mowing to allow sufficient growth for good interception of the spray.

Do not disturb soil or underground plant parts before treatment. Tillage or renovation techniques such as vertical mowing, coring or slicing should be delayed for 7 days after application to allow translocation into underground plant parts.

Desirable turfgrasses can be planted following the above procedures.

Hand-held equipment can be used for spot treatment of unwanted vegetation growing in existing turfgrass. Broadcast or hand-held equipment can be used to control sod remnants or other unwanted vegetation after sod is harvested.

Do not feed or graze turfgrass grown for seed or sod production for 8 weeks following application.

8.6 Habitat Management

Habitat Restoration and Management

Use this product to control exotic and other undesirable vegetation in habitat management and natural areas, including riparian and estuarine areas, rangeland and wildlife refuges. Applications can be made to allow recovery of native plant species, prior to planting desirable native species, and for similar broad-spectrum vegetation control requirements. Spot treatments can be made to selectively remove unwanted plants for habitat management and enhancement.

Wildlife Food Plots

Use this product as a site preparation treatment prior to planting wildlife food plots. Any wildlife food species may be planted after applying this product, or native species may be allowed to repopulate the area. If tillage is needed to prepare a seedbed, wait 7 days after application before tillage to allow translocation into underground plant parts.

8.7 Hollow Stem Injection

Apply this product through hand-held injection devices that deliver specified amounts of this product into targeted hollow-stem plants growing in any aquatic or non-crop site specified on this label. For control of the following hollow-stem plants, follow the use instructions below:

Castorbean (*Ricinus communis*)

Inject 4 mL/plant of this product into the lower portion of the main stem.

Hemlock, Poison (*Conium maculatum*)

Inject one leaf cane per plant 10 to 12 inches above root crown with 5 mL of a 5% v/v solution of this product.

Hogweed, Giant (*Heracleum mantegazzianum*)

Inject one leaf cane per plant 12 inches above root crown with 5 mL of a 5% v/v solution of this product.

Horsetail, Field (*Equisetum arvense*)

Inject one segment above the root crown with 0.5 mL/stem of this product. Use a small syringe that calibrates to this rate.

Iris, Yellow Flag (*Iris Pseudocorus*)

Cut flower stems with clippers 8 to 9 inches above the root crown. Use a cavity needle that is pushed into the stem center and then slowly removed as 0.5 mL/stem of this product is injected into the stem.

Knotweed, Bohemian (*Polygonum bohemicum*), **Knotweed, Giant** (*Polygonum sachalinense*), and **Knotweed, Japanese** (*Polygonum cuspidatum*)
Inject 5 mL/stem of this product into the second or third internode.

Reed, Common (*Phragmites australis*)

Inject 5 mL per stem of a 50% solution of this product into the second or third internode or into freshly cut stems.

Reed, Giant (*Arundo donax*)

Inject 6 mL/stem of this product into the second or third internode.

Thistle, Canada (*Cirsium arvense*)

Cut 8 to 9 of the tallest plants at bud stage in a clump with clippers. Use a cavity needle that is pushed into the stem center and then slowly removed as 0.5 mL/stem of this product is injected into the stem.

NOTE: Based on the maximum annual use rate of glyphosate for these non-crop sites, the combined total for all treatments must not exceed 8 quarts of this product per acre. At 5 mL per stem, 8 quarts should treat approximately 1500 stems.

8.8 Injection and Frill (Woody Brush and Trees)

This product can be used to control woody brush and trees by injection or frill applications. Apply using suitable equipment that must penetrate into the living tissue. Apply the equivalent of 1 mL of this product per each 2 to 3 inches of trunk diameter at breast height (DBH). This is best achieved by applying a 50- to 100-percent concentration of this product either to a continuous frill around the tree or as cuts evenly spaced around the tree below all branches. As tree diameter increases in size, better results are achieved by applying diluted material to a continuous frill or more closely spaced cuttings. Avoid application techniques that allow runoff to occur from frilled or cut areas in species that exude sap freely. In species such as this, make the frill or cuts at an oblique angle to produce a cupping effect and use a 100-percent (undiluted) concentration of this product. For best results, application should be made during periods of active growth and after full leaf expansion.

8.9 Ornamentals, Plant Nurseries, and Christmas Trees

Post-directed, Trim-and-edge

This product can be used as a post-directed spray around established woody ornamental species such as arborvitae, azalea, boxwood, crabapple, eucalyptus, euonymus, fir, douglas fir, jojoba, hollies, lilac, magnolia, maple, oak, poplar, privet, pine, spruce and yew. This product can also be used to trim and edge around trees, buildings, sidewalks and roads, potted plants and other objects in a nursery setting.

Desirable plants may be protected from the spray solution by using shields or coverings made of cardboard or other impermeable material. THIS PRODUCT IS NOT TO BE USED AS AN OVER-THE-TOP BROADCAST SPRAY IN ORNAMENTALS AND CHRISTMAS TREES. Care must be exercised to avoid contact of spray, drift or mist with foliage or bark of established ornamental species.

Site Preparation

This product can be used prior to planting any ornamental, nursery or Christmas tree species.

Wiper Applications

This product can be used through wick or other suitable wiper applicators to control or partially control undesirable vegetation around established eucalyptus or poplar trees. See the **Selective Equipment** section of this label for further information about the proper use of wiper applicators.

Greenhouse/Shadehouse

This product can be used to control weeds growing in and around greenhouses and shadehouses. Desirable vegetation must not be present during application and air circulation fans must be turned off.

8.10 Parks, Recreational and Residential Areas

All of the instructions in the **Non-Crop Areas and Industrial Sites** section apply to park and recreational areas.

This product can be used in parks, recreational and residential areas. It may be applied with any application equipment described in this label to trim-and-edge around trees, fences, and paths, around buildings, sidewalks, and other objects in these areas. This product can be used for spot treatment of unwanted vegetation and to eliminate unwanted weeds growing in established shrub beds or ornamental plantings. This product can be used prior to planting an area to ornamentals, flowers, turfgrass (sod or seed), or prior to laying asphalt or beginning construction projects.

8.11 Railroads

All of the instructions in the **Non-crop Areas and Industrial Sites** section apply to railroads.

Bare ground, Ballast and Shoulders, Crossings, and Spot Treatment

This product can be used to maintain bare ground on railroad ballast and shoulders. Repeat applications can be made as weeds emerge to maintain bare ground. This product can be used to control tall-growing weeds to improve line-of-sight at railroad crossings and reduce the need for mowing along rights-of-way. For crossing applications, up to 80 gallons of spray solution per acre may be used.

TANK MIXTURES: This product can be tank-mixed with the following products for ballast, shoulder, spot, bare ground and crossing treatments provided that the specific product is registered for use on such sites.

Arsenal	Hyvar X-L	Spike 80DF
atrazine*	Krovar I DF	Telar DF
dicamba*	Oust XP	Transline
Escort XP	Outrider	Velpar DF
Garlon 3A	Sahara DG	Velpar L
Garlon 4	simazine*	2,4-D*
Hyvar X		

*Tank mixtures with products containing this active ingredient can be made provided the specific product is registered for this use. User is responsible for ensuring that the mixture product labels allow the specific applications when tank mixing with a generic active ingredient.

Brush Control

This product can be used to control woody brush and trees on railroad rights-of-way. Apply 3 to 8 quarts of this product per acre as a broadcast spray, using boom-type or boomless nozzles. Up to 80 gallons of spray solution per acre may be used. Apply a 0.75- to 1.5-percent solution of this product when using high-volume spray-to-wet applications. Apply a 4- to 8-percent solution of this product when using low-volume directed sprays for spot treatment.

TANK MIXTURES: This product can be mixed with the following products for enhanced control of woody brush and trees provided that the specific product is registered for use on such sites.

Arsenal	Krenite	Transline
Escort XP	Telar DF	Vanquish
Garlon 3A	Tordon K	Velpar DF
Garlon 4	Tordon 22K	Velpar L

Additional instructions are located in the **Non-Crop Areas and Industrial Sites** section under **Brush Control Tank Mixtures**.

Bermudagrass Release

This product can be used to control or partially control many annual and perennial weeds for effective release of actively growing bermudagrass. Apply 12 to 36 fluid ounces of this product in up to 80 gallons of spray solution per acre. Use the lower rate when treating annual weeds below 6 inches in height (or runner length). Use the higher rate as weeds increase in size or as they approach flower or seedhead formation. These rates will also provide partial control of the following perennial species:

Bahiagrass	Fescue, tall	Trumpet creeper
Bluestem, silver	Johnsongrass	Vaseygrass

TANK MIXTURES: This product can be tank-mixed with Oust XP. If tank-mixed, use no more than 12 to 36 fluid ounces of this product with 1 to 2 ounces of Oust XP per acre. Use the lower rates of each product to control annual weeds less than 6 inches in height (or runner length) that are listed in this label and the Oust XP label. Use the higher rates as annual weeds increase in size and approach the flower or seedhead stages. These rates will also provide partial control of the following perennial weeds:

Bahiagrass	Dock, curly	Trumpet creeper
Blackberry	Dogfennel	Vaseygrass
Bluestem, silver	Fescue, tall	Vervain, blue
Broomsedge	Johnsongrass	
Dallisgrass	Poorjoe	
Dewberry	Raspberry	

Use only on well-established bermudagrass. Bermudagrass injury may result from the treatment, but regrowth will occur under moist conditions. Do not make repeat applications in the same season since severe injury may occur.

8.12 Roadsides

All of the instructions in the **Non-Crop Areas and Industrial Sites** section apply to roadsides.

Shoulder Treatments

Use this product on road shoulders and applied with boom sprayers, shielded boom sprayers, high-volume off-center nozzles, hand-held equipment, and similar equipment.

Guardrails and Other Obstacles to Mowing

This product can be used to control weeds growing under guardrails and around signposts and other objects along the roadside.

Spot Treatment

This product can be used as a spot treatment to control unwanted vegetation growing along roadsides.

TANK MIXTURES: This product can be tank-mixed with the following products for shoulder, guardrail, spot and bare ground treatments, provided that the specific tank mixture product is registered for use on such sites. Refer to these product labels and observe the cautionary statements and all other information appearing on the labels of all herbicides used. Use according to the most restrictive precautionary statements for each product in the mixture.

atrazine*	Landmark MP	Sahara DG
Crossbow L	Landmark XP	simazine*
dicamba*	Oust XP	Surflan AS
diuron*	Outrider	Surflan WDG
Escort XP	pendimethalin*	Telar DF
Endurance	Plateau	Velpar DF
Gallery 75 DF	Plateau DG	Velpar L
Krovar I DF	Poast	2,4-D*
Landmark II MP	Ronstar 50 WSP	

* Tank mixtures with products containing this generic active ingredient can be made provided the specific product is registered for this use. User is responsible for ensuring the mixture product allows the specific application.

Release of Bermudagrass or Bahiagrass

Dormant Applications

This product can be used to control or partially control many winter annual weeds and tall fescue for effective release of dormant bermudagrass or bahiagrass. Treat only when turf is dormant and prior to spring greenup. This product can also be tank-mixed with Outrider or Oust XP for residual control. Tank mixtures of this product with Oust XP may delay greenup.

For best results on winter annuals, treat when plants are in an early growth stage (below 6 inches in height) after most have germinated. For best results on tall fescue, treat when fescue is at or beyond the 4- to 6-leaf stage.

Apply 6 to 48 ounces of this product in a tank mixture with 0.75 to 1.33 ounces Outrider herbicide per acre. Read and follow all label directions for Outrider herbicide.

TANK MIXTURES: Apply 6 to 48 fluid ounces of this product per acre alone or in a tank mixture with 0.25 to 1 ounce per acre of Oust XP. Apply the labeled rates in 10 to 40 gallons of water per acre. Use only in areas where bermudagrass or bahiagrass are desirable ground covers and where some temporary injury or discoloration can be tolerated. To avoid delays in greenup and minimize injury, add no more than 1 ounce of Oust XP per acre on bermudagrass and no more than 0.5 ounce of Oust XP per acre on bahiagrass and avoid treatments when these grasses are in a semi-dormant condition.

Actively Growing Bermudagrass

This product can be used to control or partially control many annual and perennial weeds for effective release of actively growing bermudagrass. Apply 12 to 36 fluid ounces of this product in 10 to 40 gallons of spray solution per acre. Use the lower rate when treating annual weeds below 6 inches in height (or runner length). Use the higher rate as weeds increase in size or as they approach flower or seedhead formation. These rates will also provide partial control of the following perennial species:

Bahiagrass	Fescue, tall	Trumpet creeper
Bluestem, silver	Johnsongrass	Vaseygrass

TANK MIXTURES: This product can be tank-mixed with Outrider for control or partial control of Johnsongrass and other weeds listed in the Outrider label. Use 6 to 24 ounces of this product with 0.75 to 1.33 ounces of Outrider. Use the higher rates of both products for control of perennial weeds or annual weeds greater than 6 inches in height.

This product can be tank-mixed with Oust XP. If tank-mixed, use no more than 12 to 24 fluid ounces of this product with 1 to 2 ounces of Oust XP per acre. Use the lower rates of each product to control annual weeds less than 6 inches in height (or runner length) that are listed in this label and the Oust XP label. Use the higher rates as annual weeds increase in size and approach the flower or seedhead stages. These rates will also provide partial control of the following perennial weeds:

Bahiagrass	Dock, curly	Poorjoe
Bluestem, silver	Dogfennel	Trumpet creeper
Broomsedge	Fescue, tall	Vaseygrass
Dallisgrass	Johnsongrass	Vervain, blue

Use only on well-established bermudagrass. Bermudagrass injury may result from the treatment, but regrowth will occur under moist conditions. Do not make repeat applications of the tank mix in the same season since severe injury may occur.

Actively Growing Bahiagrass

For suppression of vegetative growth and seedhead inhibition of bahiagrass for approximately 45 days, apply 4 fluid ounces of this product in 10 to 40 gallons of water per acre. Apply 1 to 2 weeks after full greenup or after mowing to a uniform height of 3 to 4 inches. This application must be made prior to seedhead emergence.

For suppression up to 120 days, apply 3 fluid ounces of this product per acre, followed by an application of 2 to 3 fluid ounces per acre about 45 days later. Make no more than 2 applications per year.

This product can be used for control or partial control of Johnsongrass and other weeds listed on the Outrider label in actively growing bahiagrass. Apply 1.5 to 3.5 fluid ounces of this product with 0.75 to 1.33 ounces of Outrider per acre. Use the higher rates for control of perennial weeds or annual weeds greater than 6 inches in height. Use only on well established bahiagrass.

A tank mixture of this product plus Oust XP may be used. Apply 4 fluid ounces of this product plus 1/4 ounce of Oust XP per acre 1 to 2 weeks following an initial spring mowing. Make only one application per year.

8.13 Utility Sites

In utilities, use this product along electrical power, pipeline and telephone rights-of-way, and in other sites associated with these rights-of-way, such as substations, roadsides, railroads or similar rights-of-way that run in conjunction with utilities. Use in preparing or establishing wildlife openings within these sites, maintaining access roads and for side trimming along utility rights-of-way.

TANK MIXTURES: Tank mixtures of this product can be used to increase the spectrum of control for herbaceous weeds, woody brush and trees. Any labeled rate of this product can be used in a tank mix.

For control of herbaceous weeds, use the lower tank mixture rates. For control of dense stands or tough-to-control woody brush and trees, use the higher rates.

NOTE: For side trimming treatments, this product may be used alone or in tank mixture with Garlon 4.

Arsenal	Krenite	Surflan AS
atrazine*	Krovar I DF	Surflan WDG
dicamba*	Oust XP	Telar DF
diuron*	Outrider	Transline
Endurance	pendimethalin*	Vanquish
Escort XP	Plateau	Velpar DF
Garlon 3A**	Sahara DG	Velpar L
Garlon 4	simazine*	2,4-D*

* Tank mixtures with products containing this generic active ingredient can be made provided the specific product is registered for this use. User is responsible for ensuring the mixture product allows the specific application.

** Ensure that Garlon 3A is thoroughly mixed with water according to label directions before adding this product. Have spray mixture agitating at the time this product is added to avoid spray compatibility problems.

Bare Ground and Trim-and-Edge

Use this product in and around utility sites and substations for bare ground, trim-and-edge around objects, spot treatment of unwanted vegetation and to eliminate unwanted weeds growing in established shrub beds or ornamental plantings. This product can be used prior to planting a utility site to ornamentals, flowers, turfgrass (sod or seed), or beginning construction projects.

Repeat applications of this product as weeds emerge to maintain bare ground.

TANK MIXTURES: Tank mix with the following products. Refer to the specific product labels for approved sites and application rates. Read and carefully observe the cautionary statements and all other information appearing on the labels of all herbicides used. Use according to the most restrictive precautionary statements for each product in the mixture.

Arsenal	Garlon 3A	Poast
atrazine*	Garlon 4	Ronstar 50WSP
Barricade 65WG	Goal 2XL	simazine*
Certainty	Krovar I DF	Surflan AS
Crossbow L	Landmark II MP	Surflan WDG
dicamba*	Landmark II	Telar DF
diuron*	Outrider	Transline
Endurance	Oust XP	Velpar DF
Escort XP	pendimethalin*	Velpar L
Gallery 75DF	Plateau	2,4-D*

* Tank mixtures with products containing this generic active ingredient may be made provided the specific product is registered for this use. User is responsible for ensuring the mixture product label allows the specific application.

9.0 PASTURE AND RANGELANDS

9.1 Pastures

LABELED GRASSES: Bahiagrass, Bermudagrass, Bluegrass, Brome, Fescue, Guineagrass, Kikuyugrass, Orchardgrass, Pangola grass, Ryegrass, Timothy, Wheatgrass.

Preplant, Preemergence, Pasture Renovation

This product can be applied prior to planting or emergence of forage grasses. In addition, this product can be used to control perennial pasture species listed on this label prior to re-planting.

If application rates total 4.5 pints per acre or less, no waiting period between treatment and feeding or livestock grazing is required. If the rate is greater than 4.5 pints per acre, remove domestic livestock before application and wait 8 weeks after application before grazing or harvesting.

Spot Treatment, Over-the-Top Wiper Applications

This product can be applied as a spot treatment or with wiper applicators in pastures. Applications may be made in the same area at 30-day intervals.

For spot treatments or wiper application methods using rates of 4.5 pints per acre or less, the entire field or any portion of it may be treated. When spot treatments or wiper application are made using rates above 4.5 pints per acre, no more than 10 percent of the total pasture may be treated at any one time. To achieve maximum performance, remove domestic livestock before application and wait 7 days after application before grazing livestock or harvesting.

Postemergent Weed Control (Broadcast Treatments)

This product can be used to suppress competitive growth and seed production of annual weeds and undesirable vegetation in pastures. For selective applications with broadcast spray equipment, apply 9 to 12 fluid ounces of this product per acre in early spring before desirable perennial grasses break dormancy and initiate green growth. Late fall applications can be made after desirable perennial grasses have reached dormancy.

Some stunting of perennial grasses will occur if broadcast applications are made when plants are not dormant. No waiting period is required between application and grazing or harvesting for feed. Use of higher application rates will cause stand reductions. Do not apply more than 4.5 pints per acre per year onto pasture grasses except for renovation uses. If replanting is needed due to severe stand reduction, applications must be made at least 30 days prior to planting any grass not listed for treatment in this label.

9.2 Rangelands

Postemergence application of this product will control or suppress many annual weeds growing in perennial cool- and warm-season grass rangelands.

Preventing viable seed production is key to the successful control and invasion of annual grassy weeds in rangelands. Follow-up applications in sequential years should eliminate most of the viable seeds.

Grazing of treated areas should be delayed to encourage growth of desirable perennials. Allowing desirable perennials to flower and reseed in the treated area will encourage successful transition.

Apply 9 to 12 fluid ounces of this product per acre to control or suppress many weeds, including downy brome, cheatgrass, cereal rye and jointed goatgrass in rangelands. Apply when most brome plants are in early flower and before the plants, including seedheads, turn color. Allowing for secondary weed flushes to occur in the spring following rain events further depletes the seed reserve and encourages perennial grass conversion on weedy sites. Fall applications are possible and recommended, where spring moisture is usually limited and fall germination allows for good weed growth.

For medusahead, apply 12 fluid ounces of this product per acre at the 3-leaf stage. Delaying applications beyond this stage will result in reduced or unacceptable control. Controlled burning may be useful in eliminating the thatch layer produced by slowly decaying culms prior to application. Allow new growth to occur before spraying after a burn. Repeat applications in subsequent years may be necessary to eliminate the seedbank before reestablishing desirable perennial grasses in medusahead-dominated rangelands.

Slight discoloration of the desirable grasses may occur, but they will regreen and regrow under moist soil conditions as effects of this product wear off. Do not use ammonium sulfate when spraying rangeland grasses with this product. No waiting period between treatment and feeding of livestock grazing is required.

10.0 CROP USES

10.1 Citrus

For use in Florida and Texas on Calamondin, Chironja, Citron, Citrus Hybrids, Grapefruit, Kumquat, Lemon, Lime, Mandarin (tangerine), Orange (all), Pummelo, Satsuma Mandarin, Tangelo (ugli), Tangor.

This product can be applied preplant (site preparation) broadcast spray, middles (between rows of trees, vines or bushes), strips (within rows of trees, vines or bushes), shielded sprayers, wiper applications, directed spray, or as spot treatment.

Applications may be made with boom equipment, CDA equipment, shielded sprayers, hand-held and high-volume wands, lances, orchard guns or with wiper applicator equipment, except as directed.

The following instructions pertain to Florida and Texas.

For burndown or control of the weeds listed below, apply the labeled rates of this product in 3 to 30 gallons of water per acre. Where weed foliage is dense, use 10 to 30 gallons of water per acre.

For goatweed, apply 3 to 4.5 pints of this product per acre. Apply in 20 to 30 gallons of water per acre when plants are actively growing. Use 3 pints per acre when plants are less than 8 inches tall and 4.5 pints per acre when plants are greater than 8 inches tall. If goatweed is greater than 8 inches tall, the addition of Krovar I or Karmex may improve control. Refer to the individual product labels for specific crops, rates, geographic restrictions and precautionary statements.

Perennial weeds:

S = Suppression B = Burndown PC = Partial control C = Control

ROUNDUP CUSTOM FOR AQUATIC AND TERRESTRIAL USE RATE PER ACRE

WEED SPECIES	1.5 PT	3 PT	4.5 PT	7.5 PT
Bermudagrass	B	--	PC	C
Guineagrass				
Texas and Florida Ridge	B	C	C	C
Florida Flatwoods	--	B	C	C
Paragrass	B	C	C	C
Torpedograss	S	--	PC	C

Allow a minimum of 1 day between last application and harvest in citrus crops. For citron groves, apply as directed sprays only.

10.2 Sugarcane

This product can be applied fallow, preplant, preemergence or at-planting using hooded sprayers, shielded sprayers, or by wiper application in row-middles, as a post-harvest treatment, as a spot treatment or as foliar treatment for plant growth regulation.

Preplant, Preemergence, At-Planting

Apply this product in or around sugarcane fields or in fields prior to the emergence of plant cane. Do not apply to vegetation in or around ditches, canals or ponds containing water to be used for irrigation.

Spot Treatment

Apply this product as a spot treatment in sugarcane. For control of volunteer or diseased sugarcane, make a 0.75-percent solution of this product in water and spray-to-wet the foliage of vegetation to be controlled. Volunteer or diseased sugarcane should have at least 7 new leaves. Avoid spray contact with healthy cane plants since severe damage or destruction may result. Do not feed or graze treated sugarcane foliage following application.

Fallow Treatments

Apply this product as a replacement for tillage in fields that are lying fallow between sugarcane crops. This product can also be used to remove the last stubble of ratoon cane. For removal of last stubble of ratoon cane, apply 6 to 7.5 pints of this product in 10 to 40 gallons of water per acre to new growth having at least 7 new leaves. Allow 7 or more days after application before tillage. Ground or aerial application equipment may be used. Applications up to 4.5 pints per acre may be made by aerial application in fallow sites where there is sufficient buffer to prevent injury due to drift onto adjacent crops. Tank mixtures with 2,4-D and dicamba can be used.

Hooded Sprayers

Apply this product through hooded sprayers for weed control between the rows of sugarcane. See the **APPLICATION EQUIPMENT AND TECHNIQUES** section of this label for additional use instructions.

Do not allow treated weeds to come into contact with the crop. Droplets, mist, foam or splatter of the herbicide solution settling on the crop can result in discoloration, stunting or destruction. Such damage shall be the sole responsibility of the applicator.

Foliar Treatment for Plant Growth Regulation

Do not plant to subsequent crops other than the following for 30 days after application: Corn (All), Soybean, Sorghum (Milo), Cotton, Alfalfa, Beans (All), Forage Grasses, Potatoes (Irish, Sweet), Wheat.

When applied as directed under the conditions described, this product will hasten ripening and extend the period of high sucrose level in sugarcane. It is effective in both low- and high-tonnage sugarcane. As a result of leaf desiccation, improved trash burn can be expected. Within 2 to 3 weeks after application, this product can produce a slight yellowing to pronounced browning and drying of leaves, and a shortening of upper internodes; spindle death may occur. Most of the sucrose increase is concentrated in the top nodes of the treated cane stalk. In order to recover the maximum sugar where topping is practiced, during harvest, top at the base of the fourth leaf. Prior to application, consult your state sugarcane authority or local Monsanto representative regarding the degree of sucrose response anticipated from the variety of sugarcane to be treated.

See the following for rates and time of application for the State in which applications are to be made. **NOTE:** Use the higher rate within the specified range when treating sugarcane under adverse ripening conditions or when less responsive varieties are to be treated.

FLORIDA—Apply 6 to 14 fluid ounces of this product per acre 3 to 5 weeks before harvest of LAST RATOON CANE ONLY.

HAWAII—Apply 10 to 24 fluid ounces of this product per acre 4 to 10 weeks before harvest.

LOUISIANA—Apply 4 to 14 fluid ounces of this product per acre 3 to 7 weeks before harvest of RATOON CANE ONLY.

PUERTO RICO—Apply 6 fluid ounces of this product per acre 3 to 5 weeks before harvest of RATOON CANE ONLY.

TEXAS—Apply 6 to 14 fluid ounces of this product per acre 3 to 5 weeks before harvest of RATOON CANE ONLY.

Application of this product can initiate development of shooting eyes. This product can not increase the sucrose content of sugarcane under conditions of good natural ripening. Do not apply to sugarcane to be harvested for seed purposes. Do not feed or graze treated sugarcane forage following application.

10.3 Chemical Fallow Treatments

Apply this product during fallow intervals preceding planting, prior to planting or transplanting, at-planting, or preemergent to vegetable crops.

When applying this product prior to transplanting or direct-seeding vegetable crops into plastic mulch, care must be taken to remove residues of this product, which could cause crop injury, from the plastic prior to planting. Residues can be removed by a single 0.5-inch application of water, either by natural rainfall or via a sprinkler system. Ensure that the wash water flushes off the plastic mulch and does not enter the transplant holes. Applications made at emergence will result in injury or death to emerged seedlings.

Avoid contact of herbicide with foliage, shoots or stems, green bark, exposed roots (including those emerging from plastic mulch), or fruit of crops because severe injury or

destruction may result. Post-harvest or fallow applications must be made at least 30 days prior to planting any non-labeled crop.

10.4 Sod or Commercial Sod Production

Preplant, Preemergence, At-Planting, Renovation, Site Preparation

This product controls most existing vegetation prior to renovating turf or forage grass seed areas or establishing turf grass grown for sod. Make applications before, during, or after planting or for renovation. For maximum control of existing vegetation, delay planting to determine if any regrowth from escaped underground plant parts occurs. Where existing vegetation is growing under mowed turfgrass management, apply this product after omitting at least one regular mowing to allow sufficient growth for good interception of the spray. Where repeat treatments are necessary, sufficient regrowth must be attained prior to application. For warm-season grasses, such as Bermudagrass, summer or fall applications provide best control. Broadcast equipment may be used to control sod remnants or other unwanted vegetation after sod is harvested.

Do not disturb soil or underground plant parts before treatment. Tillage or renovation techniques such as vertical mowing, coring or slicing should be delayed for 7 days after application to allow proper translocation into underground plant parts. If application rates total 72 fluid ounces per acre or less, no waiting period between treatment and feeding or livestock grazing is required. If the rate is greater than 4.5 pints per acre, remove domestic livestock before application and wait 8 weeks after application before grazing or harvesting. For any crop not listed for treatment in this label, applications must be made at least 30 days prior to planting. Applications must be made prior to the emergence of the crop to avoid crop injury.

Shielded Sprayers

Apply 1.5 to 4.5 pints of this product in 10 to 20 gallons of water per acre to control weeds between grass seed rows. Uniform planting in straight rows aid in shielded sprayer applications. Best results are obtained when the grass seed crop is small enough to easily pass by the protective shields. For additional instructions, see **Hooded and Shielded Applicators** in the **Selective Equipment** section.

Contact of this product in any manner to any vegetation to which treatment is not intended can cause damage. Such damage shall be the sole responsibility of the applicator.

Over-the-Top Wiper Applications

Adjust applicators so that the wiper contact point is at least 2 inches above the desirable vegetation. Weeds should be a minimum of 6 inches above the desirable vegetation. Better results may be obtained when more of the weed is exposed to the herbicide solution. Weeds not contacted by the herbicide solution will not be affected. This may occur in dense clumps, severe infestations, or when height of weeds varies so that not all weeds are contacted. In these instances, repeat treatments may be necessary. For additional instructions, see **Wiper Applicators** in the **Selective Equipment** section.

Contact of the herbicide solution with desirable vegetation can result in damage or destruction.

Spot Treatment

Apply this product as a 1-percent solution prior to heading of grasses grown for seed. The crop receiving the spray in the treated area will be killed. Take care to avoid drift or spray outside the target area for the same reason. Use hand-held equipment to control sod remnants or other unwanted vegetation after sod is harvested.

Creating Rows in Annual Ryegrass

Use 12 to 24 fluid ounces of this product per acre. Use the higher rate when the ryegrass is greater than 6 inches tall. Best results are obtained when applications are made before the ryegrass reaches 6 inches in height.

Set nozzle heights to allow the establishment of the desired row spacing while preventing spray droplets, spray fines, or drift to contact the ryegrass plants not treated. Use of low-pressure nozzles, or drop nozzles designed to target the application over a narrow band are recommended.

Grower assumes all responsibility for crop losses from misapplication.

11.0 USES AROUND THE FARMSTEAD

11.1 Weed Control and Trim-And-Edge

This product can be used to control annual weeds, perennial weeds and woody brush which are found in any part of the farmstead, including building foundations, along and in fences, in dry ditches and canals, along ditchbanks, farm roads, shelterbelts, prior to landscape plantings and equipment storage areas.

This product can be tank-mixed with the following products, provided that the specific product is registered for use on such non-agricultural crop sites. Refer to these product labels for approved farmstead sites and application rates. For annual weeds, use 1.5 pints per acre of this product when weeds are less than 6 inches tall, 2.25 pints per acre when weeds are 6 to 12 inches tall and 3 pints per acre when weeds are greater than 12 inches tall. For perennial weeds, apply 3 to 7.5 pints per acre in these tank mixes. For tank mixtures with these products through backpack sprayers, handguns or other

high-volume spray-to-wet applications, see the **ANNUAL WEEDS** section for hand-held or high-volume equipment of this label for specific rates.

Arsenal	Krovar I DF	Ronstar 50 WP
Banvel/Clarity	Oust XP	Sahara
Barricade 65WG	Pendulum 3.3 EC	simazine
diuron	Pendulum WDG	Surflan
Endurance	Plateau	Telar
Escort	Princep DF	Vanquish
Karmex DF	Princep Liquid	2,4-D

This product plus dicamba tank mixtures may not be applied by air in California.

11.2 Greenhouse/Shadehouse

This product can be used to control weeds in and around greenhouses and shadehouses. Desirable vegetation must not be present during application and air circulation fans must be turned off.

11.3 Chemical Mowing

This product will suppress perennial grasses listed in this section to serve as a substitute for mowing. Use 4.5 fluid ounces of this product per acre when treating Kentucky bluegrass. Use 6 fluid ounces of this product per acre when treating tall fescue, fine fescue, orchardgrass, bahiagrass or quackgrass covers. Use 12 fluid ounces of this product per acre when treating bermudagrass. Use 48 fluid ounces of this product per acre when treating torpedograss or paragrass. Apply treatments in 10 to 20 gallons of spray solution per acre. Chemical mowing applications may be made along farm ditches and other parts of farmsteads.

Use only in areas where some temporary injury or discoloration of perennial grasses can be tolerated.

12.0 WEEDS CONTROLLED

Always use the higher rate of this product per acre within the labeled range when weed growth is heavy or dense or weeds are growing in an undisturbed (non-cultivated) area.

Reduced results can occur when treating weeds heavily covered with dust. For weeds that have been mowed, grazed or cut, allow regrowth to occur prior to treatment.

Refer to the following label sections for application rates for the control of annual and perennial weeds and woody brush and trees. For difficult to control perennial weeds and woody brush and trees, where plants are growing under stressed conditions, or where infestations are dense, use this product at 4.5 to 8 quarts per acre for enhanced results.

12.1 Annual Weeds

Apply to actively growing annual grasses and broadleaf weeds.

Allow at least 3 days after application before disturbing treated vegetation. After this period the weeds may be mowed, tilled or burned. See **DIRECTIONS FOR USE, PRODUCT INFORMATION and MIXING and APPLICATION INSTRUCTIONS** for labeled uses and specific application instructions.

Use 1.5 pints per acre if weeds are less than 6 inches in height or runner length and 1 to 4 quarts per acre if weeds are over 6 inches in height or runner length or when weeds are growing under stressed conditions.

For spray-to-wet applications, apply a 0.5-percent solution of this product to weeds less than 6 inches in height or runner length. Apply prior to seedhead formation in grass or bud formation in broadleaf weeds. For annual weeds over 6 inches tall, or for smaller weeds growing under stressed conditions, use a 0.75- to 1.5-percent solution. Use the higher labeled rate for tough-to-control species or for weeds over 24 inches tall.

WEED SPECIES

Anoda, spurred	Copperleaf, Virginia
Balsamapple**	Coreopsis, plains/tickseed*
Barley*	Corn*
Barley, little*	Crabgrass*
Barnyardgrass*	Cupgrass, woolly*
Bassia, fivehook	Dwarfdandelion*
Bittercress*	Eclipta*
Bluegrass, annual*	False dandelion*
Bluegrass, bulbous*	Falseflax, smallseed*
Brome, downy*	Fiddleneck
Brome, Japanese*	Filaree
Broomsedge	Fleabane, annual*
Buttercup*	Fleabane, hairy (<i>Conyza bonariensis</i>)*
Castorbean	Fleabane, rough*
Cheatgrass*	Foxtail*
Cheeseweed (<i>Malva parviflora</i>)	Foxtail, Carolina*
Chervil*	Geranium, Carolina
Chickweed*	Goatgrass, jointed*
Cocklebur*	Goosegrass
Copperleaf, hophornbeam	Groundsel, common*

Henbit	Rocket, London*
Horseweed/Marestail (<i>Conyza canadensis</i>)	Rocket, Yellow
Itchgrass*	Rye*
Johnsongrass, seedling	Ryegrass*
Jungerlice	Sandbur, field*
Knotweed	Sesbania, hemp
Kochia	Shattercane*
Lamb's-quarters*	Shepherd's-purse*
Lettuce, prickly*	Sicklepod
Mannagrass, eastern*	Signalgrass, broadleaf*
Mayweed	Smartweed, ladythumb*
Medusahead*	Smartweed, Pennsylvania*
Morningglory (<i>Ipomoea spp</i>)	Sorghum, grain (milo)*
Mustard, blue*	Sowthistle, annual
Mustard, tansy*	Spanishneedles***
Mustard, tumble*	Speedwell, Corn*
Mustard, wild*	Speedwell, purslane*
Nightshade, black*	Sprangletop*
Oats	Spurge, annual
Panicum, browntop*	Spurge, prostrate*
Panicum, fall*	Spurge, spotted*
Panicum, Texas*	Spurry, umbrella*
Pennycress, field*	Starthistle, yellow
Pepperweed, Virginia*	Stinkgrass*
Pigweed*	Sunflower*
Puncturevine	Teaweed / Prickly sida
Purslane, common	Thistle, Russian
Pusley, Florida	Velvetleaf
Ragweed, common*	Wheat*
Ragweed, giant	Wild oats*
Rice, red	Witchgrass*

* When using field broadcast equipment (aerial applications or boom sprayers using flat-fan nozzles) these species will be controlled or partially controlled using 12 fluid ounces of this product per acre. Applications must be made using 3 to 10 gallons of carrier volume per acre. Use nozzles that ensure thorough coverage of foliage and treat when weeds are in an early growth stage.

** Apply with hand-held equipment only.

*** Apply 3 pints of this product per acre.

12.2 Perennial Weeds

Best results are obtained when perennial weeds are treated after they reach the reproductive stage of growth (seedhead initiation in grasses and bud formation in broadleaves). For non-flowering plants, best results are obtained when the plants reach a mature stage of growth. In many situations, treatments are required prior to these growth stages. Under these conditions, use the higher application rate within the labeled range.

- Apply when target plants are actively growing. Do not treat when target plants are under drought stress.
- Ensure thorough coverage when using spray-to-wet treatments using hand-held equipment.
- When using hand-held equipment for low-volume directed spot treatments, apply a 4- to 8-percent solution of this product.
- Allow 7 or more days after application before tillage or mowing. If weeds have been mowed or tilled, do not treat until regrowth has reached the specified stages.
- Fall treatments must be applied before a killing frost.
- Repeat treatments may be necessary to control weeds regenerating from underground parts or seed.

Weed Species	Rate (QT/A)	Hand-Held % Solution
Alfalfa*	0.7	1.5
Alligatorweed*	3	1.3
Apply when most of the target plants are in bloom. Repeat applications will be required to maintain such control.		
Anise (fennel)	1.5 – 3	1 – 1.5
Bahiagrass	2.3 – 3.75	1.5
Beachgrass, European (<i>Ammophila arenaria</i>)	–	3.5
Apply an 8-percent solution of this product plus 0.5- to 1.5-percent nonionic surfactant on a low-volume spray-to-wet basis. Best results are obtained when applications are made when European beachgrass is actively growing through the boot to the full heading stages of growth. Make applications prior to the loss of more than 50% green leaf color in the fall. Repeat applications may be necessary to treat skips. Monitor treated areas prior to reseeding of desirable vegetation. For selective control of European beachgrass with wiper application, apply a 33.3-percent solution of this product plus 1 to 2.5 percent nonionic surfactant during active growth. Avoid contact of herbicide solution with desirable vegetation. Wiping the plants in opposite directions may improve performance. Maximizing the amount of individual leaf tissue contacted with the wiping equipment will result in optimal performance.		
Bentgrass*	1	1.5
Bermudagrass	4	1.5

Apply to target plants when seed heads appear.		
Bermudagrass, water (knotgrass)	1	1.5
Bindweed, field	2.3 – 3.75	1.5
Apply 3 to 3.75 quarts of this product per acre as a broadcast spray west of the Mississippi River and 2.3 to 3 quarts of this product per acre east of the Mississippi River. Apply when most target plants are at or beyond full bloom. New leaf development indicates active growth. For best results apply in late summer or fall.		
Bluegrass, Kentucky	1.5 – 2.3	0.75
Apply when most target plants have reached the boot-to-head stage of growth. When applied prior to the boot stage, less desirable control may be obtained. In the fall, apply before plants have turned brown.		
Blueweed, Texas	2.3 – 3.75	1.5
Apply 3 to 3.75 quarts of this product per acre as a broadcast spray west of the Mississippi River and 2.3 to 3 quarts of this product per acre east of the Mississippi River. Apply when most target plants are at or beyond full bloom. New leaf development indicates active growth. For best results apply in late summer or fall.		
Brackenfern	2.3 – 3	0.75 – 1
Apply to fully expanded fronds which are at least 18 inches long.		
Bromegrass, smooth	1.5 – 2.3	0.75
Apply when most target plants have reached the boot-to-head stage of growth. When applied prior to the boot stage, less desirable control may be obtained. In the fall, apply before plants have turned brown.		
Bursage, woolly-leaf	–	1.5
Canarygrass, reed	1.5 – 2.3	0.75
Apply when most target plants have reached the boot-to-head stage of growth. When applied prior to the boot stage, less desirable control may be obtained. In the fall, apply before plants have turned brown.		
Cattail	2.3 – 3.75	0.75
Apply when target plants are actively growing and are at or beyond the early-to-full bloom stage of growth. Best results are achieved when application is made during the summer or fall months.		
Clover; red, white	2.3 – 3.75	1.5
Cogongrass	2.3 – 3.75	1.5
Apply when cogongrass is at least 18 inches tall and actively growing in late summer or fall. Due to uneven stages of growth and the dense nature of vegetation preventing good spray coverage, repeat treatments may be necessary to maintain control.		
Cordgrass	See Sect 8.1	2–8
Schedule applications in order to allow 6 hours before treated plants are covered by tidalwater. When applying spray to wet with hand-held equipment, use a 2 to 8 percent solution of this product. Ensure complete coverage of clumps but do not spray to the point of run-off. Follow specific application instructions in Section 8.1 Aquatic Sites .		
Cutgrass, giant*	3	1
Repeat applications will be required to maintain such control, especially where vegetation is partially submerged in water. Allow for substantial regrowth to the 7- to 10-leaf stage prior to retreatment.		
Dallisgrass	2.3 – 3.75	1.5
Dandelion	2.3 – 3.75	1.5
Dock, curly	2.3 – 3.75	1.5
Dogbane, hemp	3	1.5
Apply when most target plants have reached the late bud-to-flower stage of growth. For best results, apply in late summer or fall.		
Fescue (except tall)	2.3 – 3.75	1.5
Fescue, tall	2.3	1
Apply when most target plants have reached the boot-to-head stage of growth. When applied prior to the boot stage, less desirable control may be obtained.		
Guineagrass	2.3	0.75
Apply when most target plants have reached at least the 7-leaf stage of growth.		
Hemlock, poison	1.5 – 3	0.75 – 1.5
Also see Hollow Stem Injection section of this label.		
Horsenettle	2.3 – 3.75	1.5
Horseradish	3	1.5
Apply when most target plants have reached the late bud-to-flower stage of growth. For best results, apply in late summer or fall.		
Iceland	1.5	1.5
Ivy; German, cape	1.5 – 3	0.75 – 1.5
Jerusalem artichoke	2.3 – 3.75	1.5
Johnsongrass	1.5 – 2.3	0.75
Apply when most target plants have reached the boot-to-head stage of growth. When applied prior to the boot stage, less desirable control may be obtained. In the fall, apply before plants have turned brown.		
Kikuyugrass	1.5 – 2.3	0.75
Knapweed	3	1.5
Apply when most target plants have reached the late bud-to-flower stage of growth. For best results, apply in late summer or fall.		
Knotweed; Bohemian, Giant, Japanese (<i>Polygonum bohemicum, P. sachalinense and P. cuspidatum</i>) Stem Injection: See the Hollow Stem Injection section of this label. Cut Stem: Cut stems cleanly just below the 2nd or 3rd node above the ground. Immediately apply 0.36 fluid ounce (10 mL) of a 50-percent solution of this product into the 'well' or remaining internode. Ensure that removed upper plant material is carefully gathered and discarded so that it will not contact soil and regenerate plants from sprouting buds. Use of a bio-barrier such as cardboard, plywood or plastic sheeting is recommended. The combined total for all treatments must not exceed 8 quarts per acre. At 10 mL of a 50-percent solution, approximately 1500 stems per acre may be treated.		

Lantana	–	0.75 – 1
Apply when most target plants are at or beyond the bloom stage of growth. Use the higher application rate for plants that have reached the woody stage of growth.		
Lespedeza	2.3 – 3.75	1.5
Loosestrife, purple	2	1 – 1.5
Treat when most target plants are at or beyond the bloom stage of growth. Best results are achieved when application is made during summer or fall months. Fall treatments must be applied before a killing frost.		
Lotus, American	2	0.75
Treat when most target plants are at or beyond the bloom stage of growth. Best results are achieved when application is made during summer or fall months. Fall treatments must be applied before a killing frost. Repeat treatment may be necessary to control regrowth from underground parts and seeds.		
Maidencane	3	0.75
Repeat treatments will be required, especially to vegetation partially submerged in water. Under these conditions, allow for regrowth to the 7- to 10-leaf stage prior to retreatment.		
Milkweed, common	2.3	1.5
Apply when most target plants have reached the late bud-to-flower stage of growth.		
Muhly, wirestem	1.5 – 2.3	0.75
Apply when most target plants are at least 8 inches in height (3 to 4-leaf stage of growth) and actively growing.		
Mullein, common	2.3 – 3.75	1.5
Napiergrass	2.3 – 3.75	1.5
Nightshade, silverleaf	2.3 – 3.75	1.5
Apply 3 to 3.75 quarts of this product per acre as a broadcast spray west of the Mississippi River and 2.3 to 3 quarts of this product per acre east of the Mississippi River. Apply when most target plants are at or beyond full bloom. Best results can be obtained when application is made after berries are formed. New leaf development indicates active growth. For best results apply in late summer or fall.		
Nutsedge, purple, yellow	2.3	0.75
Apply this product to control existing nutsedge plants and immature nutlets attached to treated plants. Apply when target plants are in flower or when new nutlets can be found at rhizome tips. Nutlets which have not germinated will not be controlled and may germinate following treatment. Repeat treatments will be required for long-term control.		
Orchardgrass	1.5 – 2.3	0.75
Apply when most target plants have reached the boot-to-head stage of growth. When applied prior to the boot stage, less desirable control may be obtained. In the fall, apply before plants have turned brown.		
Pampasgrass	2.3 – 3.75	1.5
Para grass	3	0.75
Repeat treatments may be required. Allow for regrowth to the 7- to 10-leaf stage prior to retreatment.		
Pepperweed, perennial	3	1.5
Phragmites*	2 – 3.75	0.75 – 1.5
For partial control of phragmites in Florida and the counties of other states bordering the Gulf of Mexico, apply 3.75 quarts per acre as a broadcast spray or apply a 1.5-percent solution with hand-held equipment. In other areas of the U.S., apply 2 to 3 quarts per acre as a broadcast spray or apply a 0.75-percent solution with hand-held equipment for partial control. For best results, treat during late summer or fall months when plants are actively growing and in full bloom. Due to the dense nature of the vegetation, which may prevent good spray coverage and uneven stages of growth, repeat treatments may be necessary to maintain control. Visual control symptoms will be slow to develop.		
Quackgrass	1.5 – 2.3	0.75
Apply when most target plants are at least 8 inches in height (3 to 4-leaf stage of growth) and actively growing.		
Redvine*	1.5	1.5
Reed, giant	3 – 3.75	1.5
Best results are obtained when applications are made in late summer to fall. Also see Hollow Stem Injection section of this label.		
Ryegrass, perennial	1.5 – 2.3	0.75
Apply when most target plants have reached the boot-to-head stage of growth. When applied prior to the boot stage, less desirable control may be obtained. In the fall, apply before plants have turned brown.		
Salvinia, giant	3 – 3.75	2
Apply as a 2.0% v/v spray-to-wet solution with 0.5 to 2.0% v/v of a nonionic surfactant containing at least 70% active ingredient. For broadcast applications, apply 3 to 3.75 quarts of this product with an aquatic approved surfactant system containing 0.1% v/v nonionic organosilicone and 0.25% v/v nonionic spreader sticker surfactant in 3 to 40 gallons per acre as a broadcast treatment. Allow at least 3 days after application before disturbing treated vegetation. This product does not control plants which are completely submerged or have a majority of their foliage under water.		
Smartweed, swamp	2.3 – 3.75	1.5
Spatterdock	3	0.75
Apply when most plants are in full bloom. For best results, apply during the summer or fall months.		
Spurge, leafy*	–	1.5
Starthistle, yellow	–	1.5
Sweetpotato, wild*	–	1.5
Apply when most target plants are at or beyond the bloom stage of growth. Repeat applications will be required. Allow the plant to reach the specified stage of growth before retreatment.		
Thistle, artichoke	1.5 – 2.3	2
Apply when target plants are at or beyond the bud stage of growth.		

Thistle, Canada	1.5 – 2.3	1.5
Apply when target plants are at or beyond the bud stage of growth. Also see Hollow Stem Injection section of this label.		
Timothy	1.5 – 2.3	1.5
Apply when most target plants have reached the boot-to-head stage of growth. When applied prior to the boot stage, less desirable control may be obtained. In the fall, apply before plants have turned brown.		
Torpedograss*	3 – 3.75	0.75 – 1.5
Use the lower recommended rates under terrestrial conditions and the higher rates under partially submerged or a floating mat conditions. Repeat treatments will be required to maintain such control.		
Trumpet creeper*	1.5 – 2.3	1.5
Tules, common	–	1.5
Apply to target plants at or beyond the seedhead stage of growth. After application, visual symptoms will be slow to appear and may not occur for 3 or more weeks.		
Vaseygrass	2.3 – 3.75	1.5
Velvetgrass	2.3 – 3.75	1.5
Waterhyacinth	2.5 – 3	0.75 – 1
Apply when target plants are at or beyond the early bloom stage of growth. After application, visual symptoms may require 3 or more weeks to appear with complete necrosis and decomposition usually occurring within 60 to 90 days. Use the higher recommended rates when more rapid visual effects are desired.		
Waterlettuce	–	0.75 – 1
Use higher recommended rates where infestations are heavy. Best results are obtained from mid-summer through winter applications. Spring applications may require retreatment.		
Waterprimrose	–	0.75
Apply to plants that are at or beyond the bloom stage of growth, but before fall color changes occur. Thorough coverage is necessary for best control.		
Wheatgrass, western	1.5 – 2.3	0.75
Apply when most target plants have reached the boot-to-head stage of growth. When applied prior to the boot stage, less desirable control may be obtained. In the fall, apply before plants have turned brown.		

*Partial control

Other perennials listed on this label – Apply 2.3 to 3.75 quarts of this product per acre as a broadcast spray or as a 0.75- to 1.5-percent solution with hand-held equipment. Apply when target plants are actively growing and most have reached early head or early bud stage of growth.

12.3 Woody Brush and Trees

Apply this product after full leaf expansion, unless otherwise directed. Use the higher rate for larger plants and/or dense areas of growth. On vines, use the higher rate for plants that have reached the woody stage of growth. Best results are obtained when application is made in late summer or fall after fruit formation. Apply when plants are actively growing. Thorough coverage of foliage is necessary for best results. Avoid application to drought-stressed plants.

In arid areas, best results are obtained when applications are made in the spring to early summer when brush species are at high moisture content and are flowering.

Ensure thorough coverage when using spray-to-wet treatments using hand-held equipment.

When using hand-held equipment for low-volume directed-spray spot treatments, apply a 4- to 8-percent solution of this product.

Symptoms may not appear prior to frost or senescence with fall treatments.

Allow 7 or more days after application before tillage, mowing or removal. Repeat treatments may be necessary to control plants regenerating from underground parts or seed. Some autumn colors on undesirable deciduous species are acceptable provided no major leaf drop has occurred. Reduced performance may result if fall treatments are made following a frost.

Weed Species	Broadcast Rate (QT/A)	Hand-Held Spray-To-Wet % Solution
Alder	2.3 – 3	0.75 – 1.2
Ash*	1.5 – 3.75	0.75 – 1.5
Aspen, quaking	1.5 – 2.3	0.75 – 1.2
Bearclover (Bearnat)*	1.5 – 3.75	0.75 – 1.5
Beech*	1.5 – 3.75	0.75 – 1.5
Birch	1.5	0.75
Blackberry	2.3 – 3	0.75 – 1.2
Blackgum	1.5 – 3.75	0.75 – 1.5
Bracken	1.5 – 3.75	0.75 – 1.5
Broom; French, Scotch	1.5 – 3.75	1.2 – 1.5
Buckwheat, California*	1.5 – 3	0.75 – 1.5
Cascara*	1.5 – 3.75	0.75 – 1.5
Castorbean	1.5 – 3.75	1.5
Also see Hollow Stem Injection section of this label.		
Catsclaw*	–	1.2 – 1.5
For partial control, apply this product when at least 50 percent of the new leaves are fully developed.		

Ceanothus*	1.5 – 3.75	0.75 – 1.5
Chamise*	1.5 – 3.75	0.75
Cherry; bitter, black, pin	1.5 – 3.75	1 – 1.5
Cottonwood, eastern	1.5 – 3.75	0.75 – 1.5
Coyote brush	2.3 – 3	1.2 – 1.5
For control, apply when at least 50 percent of the new leaves are fully developed.		
Cypress; swamp, bald	1.5 – 3.75	0.75 – 1.5
Deerweed	1.5 – 3.75	0.75 – 1.5
Dewberry	2.3 – 3	0.75 – 1.2
Dogwood*	3 – 3.75	1 – 2
Elderberry	1.5	0.75
Elm*	1.5 – 3.75	0.75 – 1.5
Eucalyptus, bluegum	–	1.5
For control of eucalyptus resprouts, apply this product with hand-held equipment when resprouts are 6- to 12-foot tall. Ensure complete coverage.		
Gallberry	1.5 – 3.75	0.75 – 1.5
Gorse*	1.5 – 3.75	0.75 – 1.5
Hackberry, western	1.5 – 3.75	0.75 – 1.5
Hasardia*	1.5 – 3	0.75 – 1.5
Hawthorn	1.5 – 2.3	0.75 – 1.2
Hazel	1.5	0.75
Hickory*	3 – 3.75	1 – 2
Honeysuckle	2.3 – 3	0.75 – 1.2
Hornbeam, American*	1.5 – 3.75	0.75 – 1.5
Huckleberry	1.5 – 3.75	0.75 – 1.5
Ivy, poison	3 – 3.75	1.5
Kudzu	3	1.5
Locust, black*	1.5 – 3	0.75 – 1.5
Madrone resprouts*	–	1.5
Magnolia, sweetbay	1.5 – 3.75	0.75 – 1.5
Manzanita*	1.5 – 3.75	0.75 – 1.5
Maple, red	1 – 3.75	0.75 – 1.2
For control, apply as a 0.75- to 1.2-percent solution with hand-held equipment when leaves are fully developed. For partial control, apply 1 to 3.75 quarts of this product per acre as a broadcast spray.		
Maple, sugar	–	0.75 – 1.2
For control, apply as a 0.75- to 1.2-percent solution with hand-held equipment when at least 50 percent of the new leaves are fully developed.		
Maple, vine*	1.5 – 3.75	0.75 – 1.5
Monkey flower*	1.5 – 3	0.75 – 1.5
Oak; black, white*	1.5 – 3	0.75 – 1.5
Oak; northern pin	1.5 – 3	0.75 – 1.2
For control, apply when at least 50 percent of the new leaves are fully developed.		
Oak, poison	3 – 3.75	1.5
Repeat applications may be required to maintain control. Fall treatments must be applied before leaves lose green color.		
Oak, post	2.3 – 3	0.75 – 1.2
Oak, red	–	0.75 – 1.2
For control, apply as a 0.75- to 1.2-percent solution with hand-held equipment when at least 50 percent of the new leaves are fully developed.		
Oak, scrub*	1.5 – 3	0.75 – 1.5
Oak, southern red	1.5 – 3.75	1 – 1.5
Orange, Osage	1.5 – 3.75	0.75 – 1.5
Peppertree, Brazilian (Florida holly)*	1.5 – 3.75	1.5
Persimmon*	1.5 – 3.75	0.75 – 1.5
Pine	1.5 – 3.75	0.75 – 1.5
Poplar, yellow*	1.5 – 3.75	0.75 – 1.5
Prunus	1.5 – 3.75	1 – 1.5
Raspberry	2.3 – 3	0.75 – 1.2
Redbud, eastern	1.5 – 3.75	0.75 – 1.5
Redcedar, eastern	1.5 – 3.75	0.75 – 1.5
Rose, multiflora	1.5	0.75
Treatments should be made prior to leaf deterioration by leaf-feeding insects.		
Russian olive*	1.5 – 3.75	0.75 – 1.5
Sage, black	1.5 – 3	0.75
Sage, white*	1.5 – 3	0.75 – 1.5
Sagebrush, California	1.5 – 3	0.75
Salmonberry	1.5	0.75
Saltbush	–	1
Saltcedar	3 – 3.75	1 – 2
For partial control, apply a 1- to 2-percent solution of this product with hand-held equipment or 3 to 3.75 quarts per acre as a broadcast spray. For control, apply a 1- to 2-percent solution of this product mixed with 0.25-percent Arsenal with hand-held equipment. For control using broadcast applications, apply 1.5 quarts of this product in a tank-mix with 1 pint of Arsenal to plants less than 6 feet tall. To control saltcedar greater than 6 feet tall using broadcast applications, apply 3 quarts of this product in a tank-mix with 2 pints of Arsenal.		
Sassafras*	1.5 – 3.75	0.75 – 1.5
Sea Myrtle	–	1

Sourwood*	1.5 – 3.75	0.75 – 1.5
Sumac; laurel, poison, smooth, sugarbush, winged*	1.5 – 3	0.75 – 1.5
Sweetgum	1.5 – 2.3	0.75 – 1.5
Swordfern*	1.5 – 3.75	0.75 – 1.5
Tallowtree, Chinese	–	0.75
Tanoak resprouts*	–	1.5
Thimbleberry	1.5	0.75
Tobacco, tree*	1.5 – 3	0.75 – 1.5
Toyon*	–	1.5
Trumpet creeper	1.5 – 2.3	0.75 – 1.2
Vine maple*	1.5 – 3.75	0.75 – 1.5
Virginia creeper	1.5 – 3.75	0.75 – 1.5
Waxmyrtle, southern*	1.5 – 3.75	1.5
Willow	2.3	0.75
Yerba Santa, California*	–	1.5

* Partial control

Other woody brush and trees listed in this label – For partial control, apply 1.5 to 3.75 quarts of this product per acre as a broadcast spray or as a 0.75- to 1.5-percent solution with hand-held equipment.

13.0 LIMIT OF WARRANTY AND LIABILITY

Monsanto Company warrants that this product conforms to the chemical description on the label and is reasonably fit for the purposes set forth in the Complete Directions for Use label booklet (“Directions”) when used in accordance with those Directions under the conditions described therein. NO OTHER EXPRESS WARRANTY OR IMPLIED WARRANTY OF FITNESS FOR PARTICULAR PURPOSE OR MERCHANTABILITY IS MADE. This warranty is also subject to the conditions and limitations stated herein.

Buyer and all users shall promptly notify this Company of any claims whether based in contract, negligence, strict liability, other tort or otherwise.

To the fullest extent permitted by law, buyer and all users are responsible for all loss or damage from use or handling which results from conditions beyond the control of this Company, including, but not limited to, incompatibility with products other than those set forth in the Directions, application to or contact with desirable vegetation, unusual weather, weather conditions which are outside the range considered normal at the application site and for the time period when the product is applied, as well as weather conditions which are outside the application ranges set forth in the Directions, application in any manner not explicitly set forth in the Directions, moisture conditions outside the moisture range specified in the Directions, or the presence of products other than those set forth in the Directions in or on the soil, crop or treated vegetation.

This Company does not warrant any product reformulated or repackaged from this product except in accordance with this Company’s stewardship requirements and with express written permission from this Company.

THE EXCLUSIVE REMEDY OF THE USER OR BUYER, AND THE LIMIT OF THE LIABILITY OF THIS COMPANY OR ANY OTHER SELLER FOR ANY AND ALL LOSSES, INJURIES OR DAMAGES RESULTING FROM THE USE OR HANDLING OF THIS PRODUCT (INCLUDING CLAIMS BASED IN CONTRACT, NEGLIGENCE, STRICT LIABILITY, OTHER TORT OR OTHERWISE) SHALL BE THE PURCHASE PRICE PAID BY THE USER OR BUYER FOR THE QUANTITY OF THIS PRODUCT INVOLVED, OR, AT THE ELECTION OF THIS COMPANY OR ANY OTHER SELLER, THE REPLACEMENT OF SUCH QUANTITY, OR, IF NOT ACQUIRED BY PURCHASE, REPLACEMENT OF SUCH QUANTITY. TO THE FULLEST EXTENT PERMITTED BY LAW, IN NO EVENT SHALL THIS COMPANY OR ANY OTHER SELLER BE LIABLE FOR ANY INCIDENTAL, CONSEQUENTIAL OR SPECIAL DAMAGES.

Upon opening and using this product, buyer and all users are deemed to have accepted the terms of this LIMIT OF WARRANTY AND LIABILITY which may not be varied by any verbal or written agreement. If terms are not acceptable, return at once unopened.

Roundup Custom, Certainty, Outrider, Monsanto and Vine symbol are trademarks of Monsanto Technology LLC. All others are the property of their respective owners

No license granted under any non-U.S. patent(s).

EPA Reg. No. 524-343

In case of an emergency involving this product, or for medical assistance, Call Collect, day or night, (314) 694-4000.

MONSANTO 

MONSANTO COMPANY
800 N. Lindbergh Blvd.
St. Louis, Missouri, 63167 U.S.A.
©2013
032712

SAFETY DATA SHEET



ROUNDUP CUSTOM® FOR AQUATIC & TERRESTRIAL USE

Version 1.0 / USA
102000037603

1/11
Revision Date: 09/25/2020
Print Date: 10/02/2020

SECTION 1: IDENTIFICATION OF THE SUBSTANCE/MIXTURE AND OF THE COMPANY/UNDERTAKING

Product identifier

Trade name	ROUNDUP CUSTOM® FOR AQUATIC & TERRESTRIAL USE
Product code (UVP)	86738473
SDS Number	102000037603
EPA Registration No.	524-343

Relevant identified uses of the substance or mixture and uses advised against

Use	Herbicide
Restrictions on use	See product label for restrictions.

Information on supplier

Supplier	Bayer Environmental Science A division of Bayer CropScience LP 5000 Centregreen Way, Suite 400 Cary, NC 27513 USA
----------	---

Responsible Department	Email: SDSINFO.BCS-NA@bayer.com
------------------------	---------------------------------

Emergency telephone no.

Emergency Telephone Number (24hr/ 7 days)	1-800-334-7577
---	----------------

Product Information Telephone Number	1-800-331-2867
--------------------------------------	----------------

SECTION 2: HAZARDS IDENTIFICATION

Classification in accordance with regulation HCS 29CFR §1910.1200

This material is not hazardous under the criteria of the Federal OSHA Hazard Communication Standard 29CFR 1910.1200.

Hazards Not Otherwise Classified (HNOC)

No physical hazards not otherwise classified.
No health hazards not otherwise classified.

SECTION 3: COMPOSITION/INFORMATION ON INGREDIENTS

SAFETY DATA SHEET



ROUNDUP CUSTOM® FOR AQUATIC & TERRESTRIAL USE

Version 1.0 / USA
102000037603

2/11
Revision Date: 09/25/2020
Print Date: 10/02/2020

Hazardous Component Name	CAS-No.	Concentration % by weight
Isopropylamine salt of glyphosate	38641-94-0	53.8

SECTION 4: FIRST AID MEASURES

Description of first aid measures

General advice When possible, have the product container or label with you when calling a poison control center or doctor or going for treatment.

Inhalation Move to fresh air. If person is not breathing, call 911 or an ambulance, then give artificial respiration, preferably mouth-to-mouth if possible. Call a physician or poison control center immediately.

Skin contact Wash off immediately with plenty of water for at least 15 minutes. Take off contaminated clothing and shoes immediately. Call a physician or poison control center immediately.

Eye contact Hold eye open and rinse slowly and gently with water for 15-20 minutes. Remove contact lenses, if present, after the first 5 minutes, then continue rinsing eye. Call a physician or poison control center immediately.

Ingestion Call a physician or poison control center immediately. Rinse out mouth and give water in small sips to drink. DO NOT induce vomiting unless directed to do so by a physician or poison control center. Never give anything by mouth to an unconscious person. Do not leave victim unattended.

Most important symptoms and effects, both acute and delayed

Symptoms To date no symptoms are known.

Indication of any immediate medical attention and special treatment needed

Risks This product is not a cholinesterase inhibitor.

Treatment Treatment with atropine and oximes is not indicated. Appropriate supportive and symptomatic treatment as indicated by the patient's condition is recommended.

SECTION 5: FIREFIGHTING MEASURES

Extinguishing media

Suitable Use water spray, alcohol-resistant foam, dry chemical or carbon dioxide.

Unsuitable High volume water jet

SAFETY DATA SHEET



ROUNDUP CUSTOM® FOR AQUATIC & TERRESTRIAL USE

Version 1.0 / USA
102000037603

3/11
Revision Date: 09/25/2020
Print Date: 10/02/2020

Special hazards arising from the substance or mixture	In the event of fire the following may be released: Carbon monoxide (CO), Carbon dioxide (CO ₂), Nitrogen oxides (NO _x), Oxides of phosphorus
Advice for firefighters	
Special protective equipment for firefighters	In the event of fire and/or explosion do not breathe fumes. Firefighters should wear NIOSH approved self-contained breathing apparatus and full protective clothing. Equipment should be thoroughly decontaminated after use.
Further information	Keep out of smoke. Fight fire from upwind position. Cool closed containers exposed to fire with water spray. Do not allow run-off from fire fighting to enter drains or water courses.
Flash point	does not flash
Auto-ignition temperature	No data available
Lower explosion limit	Not applicable
Upper explosion limit	Not applicable
Explosivity	Not explosive

SECTION 6: ACCIDENTAL RELEASE MEASURES

Personal precautions, protective equipment and emergency procedures

Precautions Use personal protective equipment. Keep unauthorized people away. Avoid contact with spilled product or contaminated surfaces.

Methods and materials for containment and cleaning up

Methods for cleaning up Soak up with inert absorbent material (e.g. sand, silica gel, acid binder, universal binder, sawdust). Collect and transfer the product into a properly labelled and tightly closed container. Keep in suitable, closed containers for disposal. Clean contaminated floors and objects thoroughly, observing environmental regulations.

Additional advice Use personal protective equipment. If the product is accidentally spilled, do not allow to enter soil, waterways or waste water canal. Do not allow product to contact non-target plants.

Reference to other sections Information regarding safe handling, see section 7.
Information regarding personal protective equipment, see section 8.
Information regarding waste disposal, see section 13.

SECTION 7: HANDLING AND STORAGE

Precautions for safe handling

SAFETY DATA SHEET



ROUNDUP CUSTOM® FOR AQUATIC & TERRESTRIAL USE

Version 1.0 / USA
102000037603

4/11
Revision Date: 09/25/2020
Print Date: 10/02/2020

Advice on safe handling	Avoid contact with skin, eyes and clothing. Ensure adequate ventilation.
Hygiene measures	Wash hands thoroughly with soap and water after handling and before eating, drinking, chewing gum, using tobacco, using the toilet or applying cosmetics. Remove Personal Protective Equipment (PPE) immediately after handling this product. Remove soiled clothing immediately and clean thoroughly before using again. Wash thoroughly and put on clean clothing. Keep working clothes separately. Garments that cannot be cleaned must be destroyed (burnt).
Conditions for safe storage, including any incompatibilities	
Requirements for storage areas and containers	Store in original container. Store in a cool, dry place and in such a manner as to prevent cross contamination with other crop protection products, fertilizers, food, and feed. Store in a place accessible by authorized persons only. Reacts with galvanised steel or unlined mild steel to produce hydrogen, a highly flammable gas that could explode. Protect from freezing. Partial crystallization may occur on prolonged storage below the minimum storage temperature. Freezing will affect the physical condition but will not damage the material. Thaw and mix before using.
Advice on common storage	Keep away from food, drink and animal feedingstuffs.

SECTION 8: EXPOSURE CONTROLS/PERSONAL PROTECTION

Control parameters

No known occupational limit values.

Exposure controls

Personal protective equipment

In normal use and handling conditions please refer to the label and/or leaflet. In all other cases the following recommendations would apply.

Respiratory protection

When respirators are required, select NIOSH approved equipment based on actual or potential airborne concentrations and in accordance with the appropriate regulatory standards and/or industry recommendations.

Hand protection

Please observe the instructions regarding permeability and breakthrough time which are provided by the supplier of the gloves. Also take into consideration the specific local conditions under which the product is used, such as the danger of cuts, abrasion, and the contact time.
Chemical-resistant gloves (barrier laminate, butyl rubber, nitrile rubber or Viton)
Wash gloves when contaminated. Dispose of when contaminated inside, when perforated or when contamination on the outside cannot be removed. Wash hands frequently and always before eating,

SAFETY DATA SHEET



ROUNDUP CUSTOM® FOR AQUATIC & TERRESTRIAL USE

Version 1.0 / USA
102000037603

5/11
Revision Date: 09/25/2020
Print Date: 10/02/2020

	drinking, smoking or using the toilet.
Eye protection	Use tightly sealed goggles and face protection.
Skin and body protection	Wear long-sleeved shirt and long pants and shoes plus socks.
General protective measures	Follow manufacturer's instructions for cleaning/maintaining PPE. If no such instructions for washables, use detergent and warm/tepid water. Keep and wash PPE separately from other laundry.

SECTION 9. PHYSICAL AND CHEMICAL PROPERTIES

Information on basic physical and chemical properties

Form	Liquid, clear
Colour	colorless to light yellow or brown
Odour	odourless
Odour Threshold	No data available
pH	4.4 - 4.8 (6.3 %)
Melting point/range	No data available
Boiling Point	No data available
Flash point	does not flash
Flammability	No data available
Auto-ignition temperature	No data available
Minimum ignition energy	Not applicable
Self-accelerating decomposition temperature (SADT)	No data available
Upper explosion limit	Not applicable
Lower explosion limit	Not applicable
Vapour pressure	Not applicable
Evaporation rate	No data available
Relative vapour density	No significant volatility.
Relative density	1.206 (20 °C)
Density	1.21 g/cm ³ (20 °C)
Water solubility	completely soluble
Partition coefficient: n-	Glyphosate: log Pow: -3.2

SAFETY DATA SHEET



ROUNDUP CUSTOM® FOR AQUATIC & TERRESTRIAL USE

Version 1.0 / USA
102000037603

6/11
Revision Date: 09/25/2020
Print Date: 10/02/2020

octanol/water

Viscosity, dynamic	No data available
Viscosity, kinematic	No data available
Oxidizing properties	No data available
Explosivity	Not explosive
Other information	Further safety related physical-chemical data are not known.

SECTION 10: STABILITY AND REACTIVITY

Reactivity

Thermal decomposition	Stable under normal conditions.
Chemical stability	Stable under recommended storage conditions.
Possibility of hazardous reactions	Reacts with galvanised steel or unlined mild steel to produce hydrogen, a highly flammable gas that could explode.
Conditions to avoid	Extremes of temperature and direct sunlight.
Incompatible materials	Galvanised steel, Unlined mild steel
Hazardous decomposition products	No decomposition products expected under normal conditions of use.

SECTION 11: TOXICOLOGICAL INFORMATION

Exposure routes	Skin contact, Eye contact, Inhalation
Immediate Effects	
Eye	Not expected to produce significant adverse effects when recommended use instructions are followed.
Skin	Not expected to produce significant adverse effects when recommended use instructions are followed.
Ingestion	Not expected to produce significant adverse effects when recommended use instructions are followed.
Inhalation	Not expected to produce significant adverse effects when recommended use instructions are followed.
Information on toxicological effects	
Acute oral toxicity	LD50 (Rat) > 5,000 mg/kg Test conducted with a similar formulation. No deaths

SAFETY DATA SHEET



ROUNDUP CUSTOM® FOR AQUATIC & TERRESTRIAL USE

Version 1.0 / USA
102000037603

7/11
Revision Date: 09/25/2020
Print Date: 10/02/2020

Acute inhalation toxicity	LC50 (Rat) > 4.24 mg/l Exposure time: 4 h Determined in the form of liquid aerosol. Highest attainable concentration. No deaths Test conducted with a similar formulation.
Acute dermal toxicity	LD50 (Rabbit) > 5,000 mg/kg Test conducted with a similar formulation. No deaths
Skin corrosion/irritation	No skin irritation (Rabbit) Test conducted with a similar formulation.
Serious eye damage/eye irritation	No eye irritation (Rabbit) Test conducted with a similar formulation.
Respiratory or skin sensitisation	Skin: Non-sensitizing. (Guinea pig) OECD Test Guideline 406, Buehler test Test conducted with a similar formulation.

Assessment STOT Specific target organ toxicity – single exposure

Glyphosate: Based on available data, the classification criteria are not met.

Assessment STOT Specific target organ toxicity – repeated exposure

Glyphosate did not cause specific target organ toxicity in experimental animal studies.

Assessment mutagenicity

Glyphosate was not mutagenic or genotoxic in a battery of in vitro and in vivo tests.

Assessment carcinogenicity

Glyphosate was not carcinogenic in lifetime feeding studies in rats and mice.
Important comment to IARC Listing: Our expert opinion is that classification as a carcinogen is not warranted.

ACGIH

None.

NTP

None.

IARC

Isopropylamine salt of glyphosate

38641-94-0

Overall evaluation: 2A

OSHA

None.

Assessment toxicity to reproduction

Glyphosate did not cause reproductive toxicity in a two-generation study in rats.

Assessment developmental toxicity

SAFETY DATA SHEET



ROUNDUP CUSTOM® FOR AQUATIC & TERRESTRIAL USE

Version 1.0 / USA
102000037603

8/11
Revision Date: 09/25/2020
Print Date: 10/02/2020

Glyphosate did not cause developmental toxicity in rats and rabbits.

Aspiration hazard

Based on available data, the classification criteria are not met.

SECTION 12: ECOLOGICAL INFORMATION

Toxicity to fish	LC50 (Oncorhynchus mykiss (rainbow trout)) > 1,000 mg/l static test; Exposure time: 96 h Test conducted with a similar formulation. LC50 (Lepomis macrochirus (Bluegill sunfish)) > 1,000 mg/l static test; Exposure time: 96 h Test conducted with a similar formulation.
Chronic toxicity to fish	Oncorhynchus mykiss (rainbow trout) flow-through test NOEC: \geq 9.63 mg/l The value mentioned relates to the active ingredient glyphosate.
Toxicity to aquatic invertebrates	EC50 (Daphnia magna (Water flea)) 930 mg/l static test; Exposure time: 48 h Test conducted with a similar formulation.
Chronic toxicity to aquatic invertebrates	EC50 (Daphnia magna (Water flea)): 12.5 mg/l Exposure time: 21 d The value mentioned relates to the active ingredient glyphosate.
Toxicity to aquatic plants	EbC50 (Raphidocelis subcapitata (freshwater green alga)) 72.9 mg/l static test; Exposure time: 72 h The value mentioned relates to the active ingredient glyphosate. NOEC (Raphidocelis subcapitata (freshwater green alga)) 26.4 mg/l static test; Exposure time: 72 h The value mentioned relates to the active ingredient glyphosate.
Biodegradability	Glyphosate: Not rapidly biodegradable
Koc	Glyphosate: Koc: 6920
Bioaccumulation	Glyphosate: Does not bioaccumulate.
Mobility in soil	Glyphosate: Immobile in soil
Results of PBT and vPvB assessment	
PBT and vPvB assessment	Glyphosate: This substance is not considered to be persistent, bioaccumulative and toxic (PBT). This substance is not considered to be very persistent and very bioaccumulative (vPvB).
Additional ecological	No further ecological information is available.

SAFETY DATA SHEET



ROUNDUP CUSTOM® FOR AQUATIC & TERRESTRIAL USE

Version 1.0 / USA
102000037603

9/11
Revision Date: 09/25/2020
Print Date: 10/02/2020

information

Environmental precautions Apply this product as specified on the label.
Do not apply directly to water, to areas where surface water is present or to intertidal areas below the mean high water mark.
Do not contaminate surface or ground water by cleaning equipment or disposal of wastes, including equipment wash water.
Retain and dispose of contaminated wash water.

SECTION 13: DISPOSAL CONSIDERATIONS

Waste treatment methods

Product It is best to use all of the product in accordance with label directions. If it is necessary to dispose of unused product, please follow container label instructions and applicable local guidelines.
Do not contaminate water, food, or feed by disposal.
Follow all local/regional/national/international regulations.

Contaminated packaging Follow advice on product label and/or leaflet.
Do not re-use empty containers.
Triple rinse containers.
Puncture container to avoid re-use.
Completely empty container into application equipment, then dispose of empty container in a sanitary landfill, by incineration or by other procedures approved by state/provincial and local authorities.
If burned, stay out of smoke.

RCRA Information Characterization and proper disposal of this material as a special or hazardous waste is dependent upon Federal, State and local laws and are the user's responsibility. RCRA classification may apply.

SECTION 14: TRANSPORT INFORMATION

According to national and international transport regulations this material is not classified as dangerous goods / hazardous material.

SECTION 15: REGULATORY INFORMATION

EPA Registration No.	524-343
US Federal Regulations	
TSCA list	
Water	7732-18-5

SAFETY DATA SHEET



ROUNDUP CUSTOM® FOR AQUATIC & TERRESTRIAL USE

Version 1.0 / USA
102000037603

10/11
Revision Date: 09/25/2020
Print Date: 10/02/2020

US. Toxic Substances Control Act (TSCA) Section 12(b) Export Notification (40 CFR 707, Subpt D)

No export notification needs to be made.

SARA Title III - Section 302 - Notification and Information

Not applicable.

SARA Title III - Section 313 - Toxic Chemical Release Reporting

None.

US States Regulatory Reporting

CA Prop65

This product does not contain any substances known to the State of California to cause cancer.

This product does not contain any substances known to the State of California to cause reproductive harm.

US State Right-To-Know Ingredients

None.

Environmental

CERCLA

None.

Clean Water Section 307(a)(1)

None.

Safe Drinking Water Act Maximum Contaminant Levels

None.

EPA/FIFRA Information:

This chemical is a pesticide product registered by the Environmental Protection Agency and is subject to certain labeling requirements under federal pesticide law. These requirements differ from the classification criteria and hazard information required for safety data sheets, and for workplace labels of non-pesticide chemicals. Following is the hazard information required on the pesticide label:

Signal word: Caution!

SECTION 16: OTHER INFORMATION

Abbreviations and acronyms

49CFR	Code of Federal Regulations, Title 49
ACGIH	US. ACGIH Threshold Limit Values
ATE	Acute toxicity estimate
CAS-Nr.	Chemical Abstracts Service number
CERCLA	Comprehensive Environmental Response, Compensation, and Liability Act
EINECS	European inventory of existing commercial substances
ELINCS	European list of notified chemical substances
IARC	International Agency for Research on Cancer
IATA	International Air Transport Association
IMDG	International Maritime Dangerous Goods

SAFETY DATA SHEET



ROUNDUP CUSTOM® FOR AQUATIC & TERRESTRIAL USE

Version 1.0 / USA
102000037603

11/11
Revision Date: 09/25/2020
Print Date: 10/02/2020

N.O.S.	Not otherwise specified
NTP	US. National Toxicology Program (NTP) Report on Carcinogens
OECD	Organization for Economic Co-operation and Development
TDG	Transportation of Dangerous Goods
TWA	Time weighted average
UN	United Nations
WHO	World health organisation

NFPA 704 (National Fire Protection Association):

Health - 0 Flammability - 1 Instability - 1 Others - none

HMIS (Hazardous Materials Identification System, based on the Third Edition Ratings Guide)

Health - 0 Flammability - 1 Physical Hazard - 1 PPE -

0 = minimal hazard, 1 = slight hazard, 2 = moderate hazard, 3 = severe hazard, 4 = extreme hazard

Reason for Revision: New Safety Data Sheet.

Revision Date: 09/25/2020

This information is provided in good faith but without express or implied warranty. The customer assumes all responsibility for safety and use not in accordance with label instructions. The product names are registered trademarks of Bayer.

Specimen Label



Garlon® 4

Specialty Herbicide

®Trademark of Dow AgroSciences LLC

For the control of woody plants and annual and perennial broadleaf weeds in non-crop industrial manufacturing and storage sites, rights-of-way such as electrical power lines, communication lines, pipelines, roadsides, railroads, forests and in the establishment and maintenance of wildlife openings. Use on these sites may include application to grazed areas.

Active Ingredient:

triclopyr: 3,5,6-trichloro-2- pyridinyloxyacetic acid, butoxyethyl ester	61.6%
Other Ingredients	38.4%
Total.....	100.0%

Contains petroleum distillates

Acid equivalent: triclopyr - 44.3% - 4 lb/gal

EPA Reg. No. 62719-40

Keep Out of Reach of Children

CAUTION PRECAUCION

Si usted no entiende la etiqueta, busque a alguien para que se la explique a usted en detalle. (If you do not understand the label, find someone to explain it to you in detail.)

Precautionary Statements

Hazards to Humans and Domestic Animals

Causes Moderate Eye Irritation • Harmful If Swallowed • Prolonged Or Frequently Repeated Skin Contact May Cause Allergic Reactions In Some Individuals

Avoid contact with eyes or clothing. Wash thoroughly with soap and water after handling and before eating, drinking, chewing gum, or using tobacco.

Personal Protective Equipment (PPE)

Applicators and other handlers who handle this pesticide must wear:

- Long-sleeved shirt and long pants
- Shoes plus socks

Follow manufacturer's instructions for cleaning/maintaining PPE. If no such instructions for washables are given, use detergent and hot water. Keep and wash PPE separately from other laundry.

Engineering Controls

When handlers use closed systems, enclosed cabs, or aircraft in a manner that meets the requirements listed in the WPS (40 CFR 170.240(d)(4-6)), the handler PPE requirements may be reduced or modified as specified in the WPS.

User Safety Recommendations

Users should:

- Wash hands before eating, drinking, chewing gum, using tobacco, or using the toilet.
- Remove clothing immediately if pesticide gets inside. Then wash thoroughly and put on clean clothing.

First Aid

If in eyes: Hold eye open and rinse slowly and gently with water for 15-20 minutes. Remove contact lenses, if present, after the first 5 minutes, then continue rinsing eye. Call a poison control center or doctor for treatment advice.

If swallowed: Immediately call a poison control center or doctor. Do not induce vomiting unless told to do so by a poison control center or doctor. Do not give **any** liquid to the person. Do not give anything by mouth to an unconscious person.

Note to Physician: This product may pose an aspiration pneumonia hazard. Contains petroleum distillates.

Have the product container or label with you when calling a poison control center or doctor, or going for treatment. You may also contact 1-800-992-5994 for emergency medical treatment information.

Environmental Hazards

This pesticide is toxic to fish. Do not apply directly to water, or to areas where surface water is present or to intertidal areas below the mean high water mark. Do not contaminate water when disposing of equipment washwater or rinsate.

This chemical has properties and characteristics associated with chemicals detected in groundwater. The use of this chemical in areas where soils are permeable, particularly where the water table is shallow, may result in groundwater contamination.

Physical or Chemical Hazards

Combustible. Do not use or store the product near heat or open flame.

Notice: Read the entire label. Use only according to label directions. **Before using this product, read Warranty Disclaimer, Inherent Risks of Use, and Limitation of Remedies elsewhere on this label. If terms are unacceptable, return at once unopened.**

In case of emergency endangering health or the environment involving this product, call 1-800-992-5994. If you wish to obtain additional product information, visit our web site at www.dowagro.com.

Agricultural Chemical: Do not ship or store with food, feeds, drugs or clothing.

Directions for Use

It is a violation of Federal law to use this product in a manner inconsistent with its labeling.

Read all Directions for Use carefully before applying.

Do not apply this product in a way that will contact workers or other persons, either directly or through drift. Only protected handlers may be in the area during application. For any requirements specific to your state or tribe, consult the agency responsible for pesticide regulation.

Agricultural Use Requirements

The requirements in this box apply to forestry uses.

Use this product only in accordance with its labeling and with the Worker Protection Standard, 40 CFR Part 170. This standard contains requirements for the protection of agricultural workers on farms, forests, nurseries, and greenhouses, and handlers of agricultural pesticides. It contains requirements for training, decontamination, notification, and emergency assistance. It also contains specific instructions and exceptions pertaining to the statements on this label about personal protective equipment (PPE) and restricted-entry interval. The requirements in this box only apply to uses of this product that are covered by the Worker Protection Standard.

Do not enter or allow worker entry into treated areas during the restricted entry interval (REI) of 12 hours.

PPE required for early entry to treated areas that is permitted under the Worker Protection Standard and that involves contact with anything that has been treated, such as plants, soil, or water, is:

- Coveralls
- Chemical-resistant gloves
- Shoes plus socks
- Protective eyewear

Non-Agricultural Use Requirements

The requirements in this box apply to all use sites on this label except for forestry uses.

The requirements in this box apply to uses of this product that are NOT within the scope of the Worker Protection Standard for Agricultural Pesticides (40 CFR Part 170). The WPS applies when this product is used to produce agricultural plants on farms, forests, nurseries, or greenhouses.

Entry Restrictions for Non-WPS Uses: For applications to non-cropland areas, do not allow entry into areas until sprays have dried.

Storage and Disposal

Do not contaminate water, food, or feed by storage and disposal. Open dumping is prohibited.

Pesticide Storage: Store above 28°F or agitate before use.

Pesticide Disposal: Wastes resulting from the use of this product must be disposed of on site or at an approved waste disposal facility.

Storage and Disposal (Cont.)

Nonrefillable containers 5 gallons or less:

Container Reuse: Nonrefillable container. Do not reuse or refill this container. Offer for recycling if available.

Triple rinse or pressure rinse container (or equivalent) promptly after emptying. **Triple rinse** as follows: Empty the remaining contents into application equipment or a mix tank and drain for 10 seconds after the flow begins to drip. Fill the container 1/4 full with water and recap. Shake for 10 seconds. Pour rinsate into application equipment or a mix tank or store rinsate for later use or disposal. Drain for 10 seconds after the flow begins to drip. Repeat this procedure two more times. **Pressure rinse** as follows: Empty the remaining contents into application equipment or a mix tank and continue to drain for 10 seconds after the flow begins to drip. Hold container upside down over application equipment or mix tank or collect rinsate for later use or disposal. Insert pressure rinsing nozzle in the side of the container, and rinse at about 40 psi for at least 30 seconds. Drain for 10 seconds after the flow begins to drip.

Refillable containers 5 gallons or larger:

Container Reuse: Refillable container. Refill this container with pesticide only. Do not reuse this container for any other purpose. Cleaning the container before final disposal is the responsibility of the person disposing of the container. Cleaning before refilling is the responsibility of the refiller. To clean the container before final disposal, empty the remaining contents from this container into application equipment or a mix tank. Fill the container about 10% full with water and, if possible, spray all sides while adding water. If practical, agitate vigorously or recirculate water with the pump for two minutes. Pour or pump rinsate into application equipment or rinsate collection system. Repeat this rinsing procedure two more times.

Nonrefillable containers 5 gallons or larger:

Container Reuse: Nonrefillable container. Do not reuse or refill this container. Offer for recycling if available.

Triple rinse or pressure rinse container (or equivalent) promptly after emptying. **Triple rinse** as follows: Empty the remaining contents into application equipment or a mix tank. Fill the container 1/4 full with water. Replace and tighten closures. Tip container on its side and roll it back and forth, ensuring at least one complete revolution, for 30 seconds. Stand the container on its end and tip it back and forth several times. Turn the container over onto its other end and tip it back and forth several times. Empty the rinsate into application equipment or a mix tank or store rinsate for later use or disposal. Repeat this procedure two more times.

Pressure rinse as follows: Empty the remaining contents into application equipment or a mix tank and continue to drain for 10 seconds after the flow begins to drip. Hold container upside down over application equipment or mix tank or collect rinsate for later use or disposal. Insert pressure rinsing nozzle in the side of the container, and rinse at about 40 psi for at least 30 seconds. Drain for 10 seconds after the flow begins to drip.

General Information

Use Garlon® 4 specialty herbicide for the control of woody plants and annual and perennial broadleaf weeds in non-crop industrial manufacturing and storage sites, rights-of-way such as electrical power lines, communication lines, pipelines, roadsides, railroads, forests and in the establishment and maintenance of wildlife openings. Use on these sites may include application to grazed areas.

Garlon 4 is an oil soluble, emulsifiable liquid product containing the herbicide triclopyr. Garlon 4 may be applied to woody or herbaceous broadleaf plants as a foliar spray or as a basal bark or cut stump application to woody plants. As a foliar spray, Garlon 4 controls only herbaceous plants that have emerged from the soil or woody plants that are in full leaf at the time of application. Small amounts of Garlon 4 can kill or injure many broadleaf plants. To prevent damage to crops and other desirable plants, follow all directions and precautions.

General Use Precautions and Restrictions

In Arizona: The state of Arizona has not approved Garlon 4 for use on plants grown for commercial production; specifically forests grown for commercial timber production, or on designated grazing areas.

When applying this product in tank mix combination, follow all applicable use directions, precautions, and limitations on each manufacturer's label.

Chemigation: Do not apply this product through any type of irrigation system.

Apply no more than 1/2 gallon of Garlon 4 (2 lb ae of triclopyr) per acre per growing season on rights-of-way or any area where grazing or harvesting is allowed.

On forestry sites, Garlon 4 may be used at rates up to 6 quarts (6 lb ae of triclopyr) per acre per year.

Garlon 4 may be used at rates up to 8 quarts (8 lb ae of triclopyr) per acre per year on non-crop industrial manufacturing and storage sites, rights-of-way such as electrical power lines, communication lines, pipelines, roadsides and railroads, fence rows, non-irrigation ditch banks. Portions of grazed areas that intersect treated non-cropland, rights-of-way and forestry sites may be treated at up to 8 lb ae per acre if the area to be treated on the day of application comprises no more than 10% of the total grazable area.

Do not apply Garlon 4 directly to, or otherwise permit it to come into direct contact with, cotton, grapes, peanuts, soybeans, tobacco, vegetable crops, flowers, citrus, or other desirable broadleaf plants. Do not permit spray mists containing Garlon 4 to drift onto such plants.

It is permissible to treat non-irrigation ditch banks, seasonally dry wetlands (such as flood plains, deltas, marshes, swamps, or bogs) and transitional areas between upland and lowland sites where surface water is not present except in isolated pockets due to uneven or unlevel conditions. Do not apply to open water (such as lakes, reservoirs, rivers, streams, creeks, salt water bays, or estuaries).

Do not apply on ditches currently being used to transport irrigation water. Do not apply where runoff or irrigation water may flow onto agricultural land as injury to crops may result.

Do not apply this product using mist blowers unless a drift control additive, high viscosity inverting system, or equivalent is used to control spray drift.

Sprays applied directly to Christmas trees may result in conifer injury. When treating unwanted vegetation in Christmas tree plantations, care should be taken to direct sprays away from conifers.

Garlon 4 is formulated as a low volatile ester. However, the combination of spray contact with impervious surfaces, such as roads and rocks, and increasing ambient air temperatures, may result in an increase in the volatility potential for this herbicide, increasing a risk for off-target injury to sensitive crops such as grapes and tomatoes.

Grazing and Haying Restrictions

Except for lactating dairy animals, there are no grazing restrictions following application of this product.

- **Grazing Lactating Dairy Animals:** Do not allow lactating dairy animals to graze treated areas until the next growing season following application of this product.
- Do not harvest hay for 14 days after application.
- Portions of grazed areas that intersect treated non-cropland, rights-of-way and forestry sites may be treated at up to 8 lb ae per acre if the area to be treated on the day of application comprises no more than 10% of the total grazable area.

Slaughter Restrictions: During the season of application, withdraw livestock from grazing treated grass at least 3 days before slaughter.

Avoiding Injurious Spray Drift

Make applications only when there is little or no hazard from spray drift. Small quantities of spray, which may not be visible, may seriously injure susceptible plants. Do not spray when wind is blowing toward susceptible crops or ornamental plants that are near enough to be injured. It is suggested that a continuous smoke column at or near the spray site or a smoke generator on the spray equipment be used to detect air movement, lapse conditions, or temperature inversions (stable air). If the smoke layers or indicates a potential of hazardous spray drift, do not spray.

Aerial Application: Garlon 4 may be aerially applied by fixed wing aircraft or helicopter. For aerial application on rights-of-way or other areas near susceptible crops, apply through a Microfoil[†] or Thru-Valve boom[†], or use an agriculturally labeled drift control additive. Other drift reducing systems or thickened sprays prepared by using high viscosity inverting systems may be used if they are made as drift-free as mixtures containing agriculturally labeled thickening agents or applications made with the Microfoil or Thru Valve boom. Do not use a thickening agent with the Microfoil or Thru Valve booms, or other systems that cannot accommodate thick sprays. Spray only when the wind velocity is low (follow state regulations). Avoid application during air inversions. If a spray thickening agent is used, follow all use recommendations and precautions on the product label.

[†]Reference within this label to a particular piece of equipment produced by or available from other parties is provided without consideration for use by the reader at its discretion and subject to the reader's independent circumstances, evaluation, and expertise. Such reference by Dow AgroSciences is not intended as an endorsement of such equipment, shall not constitute a warranty (express or implied) of such equipment, and is not intended to imply that other equipment is not available and equally suitable. Any discussion of methods of use of such equipment does not imply that the reader should use the equipment other than is advised in directions available from the equipment's manufacturer. The reader is responsible for exercising its own judgment and expertise, or consulting with sources other than Dow AgroSciences, in selecting and determining how to use its equipment.

Spray Drift Management

Avoiding spray drift at the application site is the responsibility of the applicator. The interaction of many equipment and weather related factors determine the potential for spray drift. The applicator and the grower are responsible for considering all these factors when making decisions.

The following drift management requirements must be followed to avoid off-target drift movement from aerial applications:

1. The distance of the outer most operating nozzles on the boom must not exceed 3/4 the length of the rotor.
2. Nozzles must always point backward parallel with the air stream and never be pointed downwards more than 45 degrees.

Where states have more stringent regulations, they should be observed.

The applicator should be familiar with and take into account the information covered in the following Aerial Drift Reduction Advisory. [This information is advisory in nature and does not supersede mandatory label requirements.]

Aerial Drift Reduction Advisory

Information on Droplet Size: The most effective way to reduce drift potential is to apply large droplets. The best drift management strategy is to apply the largest droplets that provide sufficient coverage and control. Applying larger droplets reduces drift potential, but will not prevent drift if applications are made improperly, or under unfavorable environmental conditions (see Wind, Temperature and Humidity, and Temperature Inversions).

Controlling Droplet Size:

- **Volume** - Use high flow rate nozzles to apply the highest practical spray volume. Nozzles with higher rated flows produce larger droplets.
- **Pressure** - Do not exceed the nozzle manufacturer's recommended pressures. For many nozzle types lower pressure produces larger droplets. When higher flow rates are needed, use higher flow rate nozzles instead of increasing pressure.
- **Number of Nozzles** - Use the minimum number of nozzles that provide uniform coverage.
- **Nozzle Orientation** - Orienting nozzles so that the spray is released parallel to the airstream produced larger droplets than other orientations and is the recommended practice. Significant deflection from horizontal will reduce droplet size and increase drift potential.
- **Nozzle Type** - Use a nozzle type that is designed for the intended application. With most nozzle types, narrower spray angles produce larger droplets. Consider using low-drift nozzles. Solid stream nozzles oriented straight back produce the largest droplets and the lowest drift.

Boom Length: For some use patterns, reducing the effective boom length to less than 3/4 of the wingspan or rotor length may further reduce drift without reducing swath width.

Application Height: Applications should not be made at a height greater than 10 feet above the top of the largest plants unless a greater height is required for aircraft safety. Making applications at the lowest height that is safe reduces exposure of droplets to evaporation and wind.

Swath Adjustment: When applications are made with a crosswind, the swath will be displaced downwind. Therefore, on the up and downwind edges of the field, the applicator must compensate for this displacement by adjusting the path of the aircraft upwind. Swath adjustment distance should increase, with increasing drift potential (higher wind, smaller drops, etc.).

Wind: Drift potential is lowest between wind speeds of 2 to 10 mph. However, many factors, including droplet size and equipment type determine drift potential at any given speed. Application should be avoided below 2 mph due to variable wind direction and high inversion potential. **Note:** Local terrain can influence wind patterns. Every applicator should be familiar with local wind patterns and how they affect spray drift.

Temperature and Humidity: When making applications in low relative humidity, set up equipment to produce larger droplets to compensate for evaporation. Droplet evaporation is most severe when conditions are both hot and dry.

Temperature Inversions: Applications should not occur during a local, low level temperature inversion because drift potential is high. Temperature inversions restrict vertical air mixing, which causes small suspended droplets to remain in a concentrated cloud. This cloud can move in unpredictable directions due to the light variable winds common during inversions. Temperature inversions are characterized by increasing temperatures with altitude and are common on nights with limited cloud cover and light to no wind. They begin to form as the sun sets and often continue into the morning. Their presence can be indicated by ground fog; however, if fog is not present, inversions can also be identified by the movement of the smoke from a ground source or an aircraft smoke generator. Smoke that layers and moves laterally in a concentrated cloud (under low wind conditions) indicates an inversion, while smoke that moves upward and rapidly dissipates indicates good vertical air mixing.

Sensitive Areas: The pesticide should only be applied when the potential for drift to adjacent sensitive areas (e.g., residential areas, bodies of water, known habitat for threatened or endangered species, non-target crops) is minimal (e.g., when wind is blowing away from the sensitive areas).

Ground Equipment: To aid in reducing spray drift, Garlon 4 should be used in thickened (high viscosity) spray mixtures using an agriculturally labeled drift control additive, high viscosity invert system, or equivalent as directed by the manufacturer. When using a spray thickening or inverting additive, follow all use directions and precautions on the product label. With ground equipment, spray drift can be reduced by keeping the spray boom as low as possible; by applying 20 gallons or more of spray per acre; by keeping the operating spray pressures at the lower end of the manufacturer's recommended pressures for the specific nozzle type used (low pressure nozzles are available from spray equipment manufacturers); and by spraying when wind velocity is low. In hand-gun applications, select the minimum spray pressure that will provide adequate plant coverage (without forming a mist). Do not apply with nozzles that produce a fine droplet spray. Select nozzles and pressures which provide adequate plant coverage, but minimize the production of fine spray particles.

High Volume Leaf-Stem Treatment: To minimize spray drift, keep sprays no higher than brush tops and keep spray pressures low enough to provide coarse spray droplets. An agriculturally labeled thickening agent may be used to reduce drift.

Mixing Directions

Garlon 4 may be foliarly applied by diluting with water or by preparing an oil-water emulsion. For woody plant control, an oil-water emulsion performs more dependably under a broader range of conditions than a straight water dilution and is recommended for aerial applications.

Oil-Water Mixture Sprays

Prepare a premix of oil, surfactant and Garlon 4 in a separate container using diesel fuel, fuel oil, or kerosene plus an emulsifier such as Sponto 712 or Triton X-100. Use a jar test to check spray mix compatibility before preparing oil-water emulsion sprays in the mixing tank. Do not allow any water or mixtures containing water to get into the premix or Garlon 4 since a thick "invert" (water in oil) emulsion may form that will be difficult to break. Such an emulsion may also be formed if the premix or Garlon 4 is put into the mixing tank before the addition of water. Fill the spray tank about one-half full with water, then slowly add the premix with continuous agitation and complete filling the tank with water. Continue moderate agitation.

Ground Application: Add oil to the spray mix at a rate of 5 to 10% of the total mix, up to a maximum of 1 gallon of oil per acre, using agricultural spray emulsifiers according to mixing instructions below.

Aerial Application: Use oil and water in the spray mixture in a 1:5 ratio (1 part oil to 5 parts water), up to a maximum of 1 gallon of oil per acre according to mixing instructions below.

Oil Mixture Sprays for Basal Treatment

Prepare oil-based spray mixtures using either diesel fuel, No. 1 or No. 2 fuel oil, kerosene or a commercially available basal oil. Substitute other oils or diluents only as recommended by the oil or diluent's manufacturer. When preparing an oil mixture, read and follow the use directions and precautions on the manufacturer's product label. Add Garlon 4 to the required amount of oil in the spray tank or mixing tank and mix thoroughly. If the mixture stands over 4 hours, reagitation is required.

Oil Mixtures of Garlon 4 and Tordon K: Tordon K and Garlon 4 may be used in tank mix combination for basal bark treatment of woody plants. These herbicides are incompatible and will not form a stable mixture when mixed together directly in oil. Make a stable tank mixture for basal bark application by first combining each product with a compatibility agent prior to final mixing in the desired ratio. (See product bulletin for mixing instructions.) Tordon K is not registered for use in the states of California and Florida.

Water Dilutions

For water dilutions, an agricultural surfactant at the manufacturer's recommended rate may be added to the spray mixture to provide improved wetting of foliage. To help minimize spray drift, a drift control and deposition aid cleared for application to growing crops is recommended.

Tank Mixing

Garlon 4 may be applied in tank mix combination with labeled rates of other herbicides provided (1) the tank mix product is labeled for the timing and method of application for the use site to be treated; and (2) tank mixing is not prohibited by the label of the tank mix product. When tank mixing Garlon 4 with other materials, a compatibility test (jar test) using relative proportions of the tank mix ingredients should be conducted prior to mixing ingredients in the spray tank. Use a clear glass quart jar with lid and mix the tank mix ingredients in the required order and their relative proportions. Invert the jar containing the mixture several times and observe the mixture for approximately 1/2 hour. If the mixture balls-up, forms flakes, sludges, jels, oily films or layers, or other precipitates, it is not compatible and the tank mix combination should not be used.

Mixing Order for Tank Mixes: Add one-half of the needed water to the mixing tank and start agitation. Add different materials in the order indicated below, allowing time for complete dispersion and mixing after addition of each product.

1. Water soluble herbicide (if used)
2. Premix of oil, emulsifier, Garlon 4 and other oil-soluble herbicide (if used); see below

Add the remaining water. During the final filling of the tank, add a drift control and deposition aid cleared for application to growing crops (if used), plus an agricultural surfactant (if a water dilution rather than an oil-water emulsion spray is used). Maintain continuous agitation of the spray mixture during mixing, final filling and throughout application to ensure spray uniformity.

Premixing: Prepare a premix of oil, emulsifier (if oil-water emulsion), and Garlon 4 plus other oil-soluble herbicide (if used), e.g., 2,4-D ester. **Note:** Do not allow water or mixtures containing water to get into the premix or Garlon 4 since a thick "invert" (water in oil) emulsion may form that will be difficult to break. Such an emulsion may also be formed if the premix or Garlon 4 is put into the mixing tank before the addition of water.

Tank Mixing Precautions:

- Read carefully and follow all applicable use directions, precautions, and limitations on the respective product labels.
- Do not exceed recommended application rates. If products containing the same active ingredient are tank mixed, do not exceed the maximum allowable active ingredient use rates.
- For direct injection or other spray equipment where the product formulations will be mixed in undiluted form, special care should be taken to ensure tank mix compatibility.
- Always perform a (jar) test to ensure the compatibility of products to be used in tank mixture.

Mixing with Liquid Fertilizer for Broadleaf Weed Control

Garlon 4 may be tank mixed with liquid nitrogen fertilizer and foliarly applied for weed control and fertilization of grass pastures. Use Garlon 4 in accordance with recommendations for grass pastures as given on this label. Apply at rates recommended by supplier or Extension Service Specialist. **Note:** Garlon 4 is not recommended for use with liquid fertilizer on woody plants (brush). Foliage burn caused by liquid fertilizer may reduce herbicide effectiveness on woody plants. Test for mixing compatibility using desired procedure and spray mix proportions in clear glass jar before mixing in spray tank. A compatibility aid such as Unite or Compex may be needed in some situations. **Compatibility is best with straight liquid nitrogen fertilizer solutions. Mixing with N-P-K solutions or suspensions may not be satisfactory even with the addition of compatibility aid.** Premixing Garlon 4 with 1 to 4 parts water may help in difficult situations.

Fill in the spray tank about half full with the liquid fertilizer, then add the herbicide with agitation and complete filling the tank with fertilizer. Apply immediately and continue agitation in the spray tank during application.

Do not store liquid fertilizer spray mixtures. Application during very cold weather (near freezing) is not advisable. The likelihood of mixing or compatibility problems with liquid fertilizer increases under cold conditions.

Note: Do not use spray equipment for other applications to land planted, or to be planted, to susceptible crops or desirable plants **unless** it has been determined that all phytotoxic herbicide residue has been removed by thoroughly cleaning the equipment.

Plants Controlled by Garlon 4

Woody Plant Species

alder	cottonwood	maple (except bigleaf, vine ³)	sweetbay magnolia
arrowwood	crataegus (hawthorn)	milkweed vine ³	sweetgum
ash	dogwood	mulberry	sycamore
aspen	Douglas-fir	oaks	tanoak
bear clover (bearmat)	elderberry	osage orange	thimbleberry
beech	elm (except winged elm)	pepper vine ³	tree-of-heaven (<i>Ailanthus</i>) ¹
birch	gallberry	persimmon, eastern	trumpet creeper ²
blackberry	gorse	pine	tulip poplar
blackbrush	granjeno	poison ivy	twisted acacia
blackgum	guajillo	poison oak	Virginia creeper ²
boxelder ¹	guava ³	poplar	wax myrtle (top growth)
Brazilian pepper	hazel	salmonberry	wild rose
buckthorn	hickory	saltbush (<i>Braccharis</i> spp.) ³	willow
cascara	hombearm	salt cedar ¹	willow primrose
ceanothus	huisache (suppression)	sassafras	winged elm
cherry ³	kudzu ²	scotch broom	
chinquapin	locust	sumac	
choke cherry	madrone		

¹For best control, use either a basal bark or cut stump treatment.

²For complete control, re-treatment may be necessary.

³Basal or dormant stem applications only.

Annual, Biennial and Perennial Broadleaf Weeds

Note: Numbers in parentheses refer to footnotes below table.

black medic	dandelion (top growth)	Oxalis	vetch
bull thistle	dogfennel	plantain	wild carrot
burdock	field bindweed	purple loosestrife	(Queen Anne's lace)
Canada thistle	goldenrod	ragweed	wild lettuce
chicory	ground ivy	sericea lespedeza (1)	wild violet
cinquefoil	lambsquarters	smartweed	yarrow
clover	lespedeza	sulfur cinquefoil (2)	
creeping beggarweed	matchweed	sweet clover	
curly dock	mustard	tropical soda apple (3)	

- Sericea lespedeza:** Apply 1 to 2 pints of Garlon 4 per acre. For best results, apply after maximum foliage development in the late spring to early summer, but prior to bloom.
- Sulfur cinquefoil:** Apply 1 to 2 pints of Garlon 4 per acre. For best results, apply to plants in the rosette stage.
- Tropical soda apple:** Apply 2 pints of Garlon 4 per acre when tropical soda apple plants reach the first flower stage. For best results, apply in a total spray volume of 40 gallons per acre using ground equipment. An agricultural surfactant may be added at the manufacturer's recommended rate to provide more complete wetting and coverage of the foliage. Spot treatments may be used to control sparse plant stands. For spot treatment use a 1 to 1.5% solution of Garlon 4 in water (1 to 1 1/2 gallons of Garlon 4 in 100 gallons total spray mixture) and spray the entire plant to completely wet the foliage. **In Florida,** control of tropical soda apple may be improved by using the following management practices:

- Mow plants to a height of 3 inches every 50 to 60 days or whenever they reach flowering. Continue the mowing operation through April.
- In late May to June (50 to 60 days after the April mowing), apply Garlon 4 as a broadcast treatment.
- Use spot treatment to control any remaining plants or thin stands of plants that germinate following a broadcast treatment.

Application Methods

Use Garlon 4 at rates of 1 to 8 quarts per acre to control broadleaf weeds and woody plants. It is suggested that rates higher in this rate range be used to control woody plants. In all cases, use the amount specified in enough water to give uniform and complete coverage of the plants to be controlled. The order of addition to the spray tank is water, spray thickening agent (if used), surfactant (if used), additional herbicide (if used), and Garlon 4. If a standard agricultural surfactant is used, use at a rate of 1 to 2 quarts per acre. Use continuous adequate agitation.

Before using any recommended tank mixtures, read the directions and all precautions on both labels.

For best results apply when woody plants and weeds are actively growing. When hard to control species such as ash, blackgum, choke cherry, elm, maples (other than vine or big leaf), oaks, pines, or winged elm are prevalent, during applications made during late summer when the plants are mature, or during drought conditions, use the higher rates of Garlon 4 alone or in combination with Tordon® 101 Mixture specialty herbicide or Tordon K herbicide. Tordon 101 Mixture and Tordon K are restricted use pesticides. Tordon 101 Mixture and Tordon K are not registered for use in the states of California and Florida.

When using Garlon 4 in combination with 2,4-D low volatile ester herbicide, generally the higher rates of Garlon 4 should be used for satisfactory brush control.

Use the higher dosage rates when brush approaches an average of 15 feet in height or when the brush covers more than 60% of the area to be treated. If lower rates are used on hard to control species, resprouting may occur the year following treatment.

On sites where easy to control brush species dominate, rates less than those listed may be effective. Consult state or local extension personnel for such information.

Foliage Treatment With Ground Equipment

Use sufficient spray volume to completely and uniformly cover foliage. For ground application, apply 10 gallons or more of total spray volume per acre. Use higher spray volumes for ground applications to ensure adequate coverage with increased depth and density of foliage, particularly for treatment of woody plants.

High Volume Foliage Treatment

For control of woody plants, use Garlon 4 at the rate of 2 to 6 quarts per 100 gallons of spray mixture, or Garlon 4 at 2 to 4 quarts may be tank mixed with labeled rates of 2,4-D low volatile ester herbicide. Tordon 101 Mixture, or Tordon K and diluted to make 100 gallons of spray. Do not apply more than 2 gallons of Garlon 4 per acre. On rangeland and permanent pasture sites, make 1 application per year and apply no more than 2 quarts of Garlon 4 (2 lb ae of triclopyr) per acre. Apply at a volume of 100 to 400 gallons of total spray per acre depending upon size and density of woody plants. Tordon 101 Mixture and Tordon K are not registered for use in the states of California and Florida. When tank mixing, follow applicable use directions and precautions on each manufacturer's label.

Depending upon the size and density of the woody plants, apply sufficient spray volume to thoroughly wet all leaves, stems, and root collars. To minimize spray drift, select the minimum spray pressure that provides adequate plant coverage without forming a mist and direct sprays no higher than the top of the target plants. Use a drift control additive cleared for application to growing crops to reduce spray drift. Before using any tank mixture, read the directions and use precautions on both labels. For best results, apply when woody plants and weeds are actively growing.

Table 1: The following table is provided as a guide to the user to achieve the proper rate of Garlon 4.

Total Spray Volume (gallons/acre)	Rate of Garlon 4	
	Forestry Sites (qt/100 gallons of spray) ¹	Non-Cropland Sites (qt/100 gallons of spray) ²
400	1.5	2
300	2	2.7
200	3	4
100	6	8
50	12	16
40	15	20
30	20	26.7
20	30	40
10	60	80

¹Do not exceed the maximum use rate of 6 qt of Garlon 4 (6 lb ae of triclopyr) per acre per year.

²Do not exceed the maximum use rate of 8 qt of Garlon 4 (8 lb ae of triclopyr) per acre per year for non-grazable areas, or 2 qt (2 lb ae of triclopyr) per acre per year for grazed areas, except on portions of grazed areas that meet the following requirement. Portions of grazed areas that intersect treated non-cropland, rights-of-way and forestry sites may be treated at up to 8 lb ae per acre if the area to be treated on the day of application comprises no more than 10% of the total grazable area.

Table 2

Application Rates per 100 Gallons of Spray		
Garlon 4	Plus Tank Mix Product	Rate (qt)
1 - 4 qt	--	--
1 - 2 qt	Grazon [®] P+D specialty herbicide	4
1 - 2 pt	2,4-D low volatile ester herbicide	1 - 2
1 - 2 qt	Tordon 22K	1 - 2
2 qt	Reclaim [®] specialty herbicide ^{1,2}	2

¹ Reclaim is registered for use only in Arizona, Texas, Oklahoma and New Mexico.

² See directions for Mesquite Control Using High Volume Foliage Treatment below.

Mesquite Control Using High Volume Foliage Treatment: For control of mesquite infestations of low to moderate density, apply Garlon 4 and Reclaim in a tank mixture to individual plants with backpack or hand-held sprayers or a vehicle-mounted sprayer with hand-held spray wand or spray gun. For individual plant treatment, use 2 quarts of Garlon 4 in combination with 2 quarts of Reclaim per 100 gallons of total spray solution (1/2% v/v of each product). Apply in water or as an oil-water emulsion as described in Mixing Directions. If using an oil-water emulsion, add the oil at a rate of 5% of the total spray volume. Apply as a complete spray-to-wet foliar application, including all leaves. Thorough coverage is necessary for good results, but do not spray to the point of runoff. Do not apply when mesquite foliage is wet. The total amount of Garlon 4 applied should not exceed 1 1/3 pints per acre. For best results, follow information given elsewhere in this label concerning effect of environmental conditions and application timing on control. This application method works best for brush less than 8 feet tall since efficient treatment and thorough coverage of taller brush is difficult to achieve with this method. To minimize drift, select a spray nozzle and pressure that provides good coverage while forming a coarse spray. Additionally, drift may be reduced by using the minimum pressure necessary to obtain plant coverage without forming a mist and by directing sprays no higher than the top of target plants. If desired, a spray dye may be added to the spray mixture to mark the treated plants.

Low Volume Foliage Treatment

To control susceptible woody plants, mix up to 20 quarts of Garlon 4 in 10 to 100 gallons of finished spray. The spray concentration of Garlon 4 and total spray volume per acre should be adjusted according to the size and density of target woody plants and kind of spray equipment used. With low volume sprays, use sufficient spray volume to obtain uniform coverage of target plants including the surfaces of all foliage, stems, and root collars (see General Use Precautions and Restrictions). For best results, a surfactant should be added to all spray mixtures. Match equipment and delivery rate of spray nozzles to height and density of woody plants. When treating tall, dense brush, a truck mounted spray gun with spray tips that deliver up to 2 gallons per minute at 40 to 60 psi may be required. Backpack or other types of specialized spray equipment with spray tips that deliver less than 1 gallon of spray per minute may be appropriate for short, low to moderate density brush.

Tank Mixing: As a low volume foliage spray, up to 12 quarts of Garlon 4 may be applied in tank mix combination with labeled rates of Tordon K or Tordon 101 Mixture in 10 to 100 gallons of finished spray. Tordon 101 Mixture and Tordon K are not registered for use in the states of California and Florida.

Broadcast Applications With Aerial or Ground Equipment

Environmental conditions and application timing influence brush and weed control results. For best results, apply when woody plants and weeds are actively growing. For woody species, apply after the rapid growth period of early spring when leaf tissue is fully expanded and terminal growth has slowed. Brush regrowth should be at least 4 ft high prior to treatment to insure adequate foliage for herbicide absorption. Adequate soil moisture before and after treatment as well as the presence of healthy foliage at the time of application are important factors contributing to optimal herbicidal activity.

Use sufficient spray volume to completely and uniformly cover foliage. For ground application, apply 10 gallons or more of total spray volume per acre. For aerial application, apply at least 2 gallons of total spray volume per acre. Use higher spray volumes for ground or aerial applications to ensure adequate coverage with increased depth and density of foliage, particularly for treatment of woody plants.

Mesquite: The herbicidal response of mesquite is strongly influenced by foliage condition, growth stage and environmental conditions. For best results, apply when new growth foliage has turned from light to dark green, when the soil temperature is above 75°F at a depth of 12 to 18 inches, and soil moisture is adequate for plant growth. Apply within 60 days after the 75°F minimum soil temperature at the 12- to 18-inch depth has been reached. Product performance may be adversely affected if application is made before mesquite foliage has turned from light to dark green or if foliage has been injured or removed by late frost, insects, hail or plant diseases. Do not treat if mesquite exhibits new (light green) terminal growth in response to recent heavy rainfall during the growing season. Rate of soil warm-up at the 12- to 18-inch depth may vary with soil texture and drainage. Coarse-textured (sandy) soils warm up sooner than fine-textured (clay) soils and dry soils warm up more quickly than wet soils. Mesquite regrowth should be at least 4 ft high prior to treatment to insure adequate foliage for herbicide absorption.

Mesquite Only

Apply 1/2 to 1 pint of Garlon 4 per acre in combination with 2/3 to 1 1/3 pint per acre of Reclaim. See label for Reclaim for additional treatment recommendations and information on mesquite control. Apply aerially as an oil:water emulsion in 4 gallons or more total volume per acre or with ground equipment in 10 gallons or more total volume per acre. Use a maximum of 1 gallon of oil per acre for aerial or ground application.

Mesquite and Pricklypear Cactus

If pricklypear cactus is a target species in association with mesquite, apply a tank mix of 1/2 to 1 pint of Garlon 4 with 1 to 2 pints of Tordon 22K per acre. (The 2 pint per acre rate of Tordon 22K provides a higher and more uniform plant kill of pricklypear.) Tordon 22K may also be applied in combination with Reclaim to control pricklypear while providing improved control of mesquite. See labels for Tordon 22K and Reclaim for additional information and treatment recommendations. Apply aerially as an oil:water emulsion in 4 gallons or more total volume per acre or with ground equipment in 10 or gallons or more total volume per acre. If mesquite canopy is dense, use higher spray volumes. Use a maximum of 1 gallon of oil per acre for aerial or ground application.

South Texas Mixed Brush (Mesquite, Pricklypear Cactus, Blackbrush, Twisted Acacia and Granjeno)

Use 1 to 2 pints of Garlon 4 in a tank mix with 2 pints of Tordon 22K per acre if pricklypear is a problem, or with 2/3 to 1 1/3 pints of Reclaim per acre if mesquite is the prevalent species. Garlon 4 contributes to the control of non-legume species such as granjeno and oaks. However, if woody legume species are predominate, apply 2 pints of Tordon 22K per acre in combination with 2/3 to 1 1/3 pints of Reclaim per acre for improved control. See labels for Tordon 22K and Reclaim for additional information and treatment recommendations. Apply aerially in an oil:water emulsion in 4 gallons or more total volume per acre or with ground equipment in 15 gallons or more total volume per acre. Use a maximum of 1 gallon of oil per acre for aerial or ground application. The use of an oil:water emulsion is critical and good spray coverage is essential for acceptable brush control.

Sand Shinnery Oak Suppression

In Texas, New Mexico and Oklahoma, apply Garlon 4 alone at a rate of 1/2 to 2 pints per acre for suppression of shinnery oak growing on sandy soils. Grass response following suppression may be impressive where rainfall is adequate. Grazing deferment following application together with proper grazing management is recommended to allow for the reestablishment of grass stands.

Post Oak and Blackjack Oak - Regrowth Stands

Apply in the late spring (May) to early summer (June-July) when oak leaves are fully developed (expanded). Use 2 quarts of Garlon 4 alone or in tank mix combination with 0.5 to 1 pints of 2,4-D low-volatile ester herbicide per acre. Apply in an oil:water emulsion or water surfactant dilution in sufficient total volume per acre to assure thorough coverage, usually 5 gallons or more per acre by fixed-wing aircraft or helicopter or 15 to 25 gallons per acre by ground equipment. Use a maximum of 1 gallon of oil per acre for aerial or ground application. Lower rates may be used for suppression only. Control will require at least 3 consecutive treatments. **Note:** Regrowth plants have a large root mass relative to top growth when compared to undisturbed plants. In order for top growth to intercept and translocate enough herbicide to control the roots, delay broadcast treatment until top growth is at least 4 ft tall.

High Volume Foliage Treatment: For regrowth less than 4 ft tall, apply 2 quarts of Garlon 4 per 100 gallons of water and 2 quarts of ag surfactant alone or in tank mix combination with 1 gallon of Grazon P+D or 1 quart of Tordon 22K. Apply as a high volume leaf-stem treatment to individual plants using ground equipment.

Post Oak and Blackjack Oak - Mature Stands

For control of mature stands (greater than 5 ft tall), apply 2 quarts of Garlon 4 per acre in late spring (May) to early summer (June-July) when oak leaves are fully developed (expanded). Understory species such as winged elm, buckbrush, tree huckleberry and ash occurring in some areas will not be controlled (only suppressed or defoliated) by using Garlon 4 alone. Where these understory species occur, control may be improved by tank mixing 2 quarts of Garlon 4 with 1 quart of Tordon 22K or 4 quarts of Grazon P+D per acre. For best results, apply as an oil:water emulsion in a total volume of 5 gallons per acre or more by fixed-wing aircraft or helicopter.

Other Susceptible Woody Plants

Apply 2 to 4 pints of Garlon 4 alone or in combination with 2 to 3 quarts of 3.8 lb/gal 2,4-D low volatile ester or amine formulation per acre. If difficult to control species such as ash, choke cherry, elm, maple or oaks are prevalent, and during applications made when plants are mature late in the summer or during drought conditions, use the higher rates of Garlon 4, alone or with 2,4-D. Garlon 4 may also be applied in a tank mixture with Grazon P+D or Tordon 22K for increased control of certain species. See labels for Grazon P+D and Tordon 22K for additional information and treatment recommendations. Apply aerially in 4 gallons or more total volume per acre or with ground equipment in 10 gallons or more total volume per acre. For best results on blackberry, apply during or after bloom. For management of kudzu, apply 1 quart of Garlon 4 per acre. Repeat application may be necessary to achieve desired level of control.

Susceptible Broadleaf Weeds

Use 2 pints of Garlon 4 per acre in a water spray. Apply as a broadcast spray in a total volume of 10 gallons or more per acre by ground equipment or aerially in a total volume of 2 gallons or more per acre. Apply anytime the weeds are actively growing. Garlon 4 at 1/2 to 3 pints may be tank mixed with 1 to 2 quarts of 3.8 lb/gal 2,4-D amine or low volatile ester.

Woody Plant Control

Foliage Treatment: Use 4 to 8 quarts of Garlon 4 in enough water to make 5 gallons or more per acre of total spray, or 1 1/2 to 3 quarts of Garlon 4 may be combined with labeled rates of 2,4-D low volatile ester, Tordon 101 Mixture, or Tordon K in sufficient water to make 5 gallons or more per acre of total spray. Tordon 101 Mixture and Tordon K are not registered for use in the states of California and Florida.

Broadleaf Weed Control

Use Garlon 4 at rates of 1 to 4 quarts in a total volume of 5 gallons or more per acre as a water spray mixture. Apply anytime weeds are actively growing. Garlon 4 at 0.25 to 3 quarts may be tank mixed with labeled rates of 2,4-D amine or low volatile ester, Tordon K, or Tordon 101 Mixture to improve the spectrum of activity. For thickened (high viscosity) spray mixtures, Garlon 4 can be mixed with diesel oil or other inverting agent. When using an inverting agent, read and follow the use directions and precautions on the product label. Tordon 101 Mixture and Tordon K are not registered for use in the states of California and Florida.

Foliage Treatment (Utility and Pipeline Rights-of-Way)

Use 4 to 8 quarts of Garlon 4 alone, or 3 to 4 quarts of Garlon 4 in a tank mix combination with labeled rates of 2,4-D low volatile ester, Tordon 101 Mixture or Tordon K and apply in a total spray volume of 10 to 30 gallons per acre. Use the higher rates and volumes when plants are dense or under drought conditions. Tordon 101 Mixture and Tordon K are not registered for use in the states of California and Florida.

Portions of grazed areas that intersect treated non-cropland, rights-of-way and forestry sites may be treated at up to 8 lb ae per acre if the area to be treated on the day of application comprises no more than 10% of the total grazable area.

Basal Bark, Dormant Stem and Cut Surface Treatments

Individual plant treatments such as basal bark and cut surface applications may be used on any use site listed on this label at a maximum use rate of 8 lb ae of triclopyr per acre. These types of applications are made directly to ungrazed parts of plants and, therefore, are not restricted by the grazing maximum rate of 2 lb ae of triclopyr per acre.

Basal Bark Treatment

To control susceptible woody plants with stems less than 6 inches in basal diameter, mix 1 to 5 gallons of Garlon 4 in enough oil to make 100 gallons of spray mixture. Apply with knapsack sprayer or power spraying equipment using low pressure (20 to 40 psi). Spray the basal parts of brush and tree trunks to a height of 12 to 15 inches from the ground, thoroughly wetting the indicated area. Spray until runoff at the ground line is noticeable. Old or rough bark requires more spray than smooth young bark. Apply anytime, including the winter months, except when snow or water prevent spraying to the ground line. **Mixing with oil requires vigorous agitation to form an oil solution.** Once a solution is formed it will stay stable.

Low Volume Basal Bark Treatment

To control susceptible woody plants with stems less than 6 inches in basal diameter, mix 20 to 30 gallons of Garlon 4 in enough oil to make 100 gallons of spray mixture. Apply with a backpack or knapsack sprayer using low pressure and a solid cone or flat fan nozzle. Spray the basal parts of brush and tree trunks to a height of 12 to 15 inches from the ground in a manner that thoroughly wets the lower stems, including the root collar area, but not to the point of runoff. Herbicide concentration should vary with size and susceptibility of species treated. Apply anytime, including the winter months, except when snow or water prevent spraying to the ground line or when stem surfaces are saturated with water. See Table 1 for relationship between mixing rate, spray volume and maximum application rate. **Note:** The addition of a soil active herbicide to a basal bark mixture with Garlon 4 may result in damage to surrounding non-target vegetation. Care should be taken to assess the areas in which these soil active herbicides are used in combination with Garlon 4 in basal bark applications. **Mixing with oil requires vigorous agitation to form an oil solution.** Once a solution is formed it will stay stable.

Garlon 4 Plus Tordon K in Oil Tank Mix: Garlon 4 and Tordon K may be used in tank mix combination as a low volume basal bark treatment to improve control of certain woody species such as ash, elm, maple, poplar, aspen, hackberry, oak, oceanspray, birch, hickory, pine, tanoak, cherry, locust, sassafras, and multiflora rose. (See product bulletin for mixing instructions.) Tordon K is not registered for use in the states of California and Florida.

Streamline Basal Bark Treatment (Southern States)

To control or suppress susceptible woody plants for conifer release, mix 20 to 30 gallons of Garlon 4 in enough oil to make 100 gallons of spray mixture. Streamline basal bark treatments are most effective on stems less than 4 inches in basal diameter. Apply with a backpack or knapsack sprayer using equipment that provides a directed straight stream spray. Apply the spray in a 2- to 3-inch wide band to one side of stems less than 3 inches in basal diameter. When the optimum amount of spray mixture is applied, the treated zone should widen to encircle the stem within approximately 30 minutes. Treat both sides of stems which are 3 to 4 inches in basal diameter. Direct the spray at bark that is approximately 12 to 24 inches above ground. Pines (loblolly, slash, shortleaf, and Virginia) up to 2 inches in diameter breast height (dbh) can be controlled by directing the spray at a point approximately 4 feet above ground. Vary spray mixture concentration with size and susceptibility of the species being treated. Better control is achieved when spray is applied to thin juvenile bark and above rough thickened mature bark. This technique is not recommended for scrub and live oak species, including blackjack, turkey, post, live, bluejack and laurel oaks, or bigleaf maple. Apply anytime, including winter months, except when snow or water prevents spraying at the desired height above ground level. **Note:** Best results with some hardwood species occur when applications are made from approximately 6 weeks prior to leaf expansion in the spring until approximately 2 months after leaf expansion is completed. **Mixing with oil requires vigorous agitation to form an oil solution.** Once a solution is formed it will stay stable.

Low Volume Stem Bark Band Treatment (North Central and Lake States)

To control susceptible woody plants with stems less than 6 inches in basal diameter, mix 20 to 30 gallons of Garlon 4 in enough oil to make 100 gallons of spray mixture. Apply with a backpack or knapsack sprayer using low pressure and a solid cone or flat fan nozzle. Apply the spray in a 6- to 10-inch wide band that completely encircles the stem. Spray in a manner that completely wets the bark, but not to the point of runoff. The treatment band may be positioned at any height up to the first major branch. For best results, apply the band as low as possible. Spray mixture concentration should vary with size and susceptibility of species to be treated. Applications may be made anytime, including winter months. **Mixing with oil requires vigorous agitation to form an oil solution.** Once a solution is formed it will stay stable.

Thinline Basal Bark Treatment

To control susceptible woody plants with stems less than 6 inches in diameter, apply Garlon 4, either undiluted or mixed at 50 to 75% v/v with oil, in a thin stream to all sides of the lower stems. The stream should be directed horizontally to apply a narrow band of Garlon 4 around each stem or clump. Use a minimum of 2 to 15 milliliters of Garlon 4 or oil mixture with Garlon 4 to treat single stems and from 25 to 100 milliliters to treat clumps of stems. Use an applicator metered or calibrated to deliver the small amounts required. **Mixing with oil requires vigorous agitation to form an oil solution.** Once a solution is formed it will stay stable.

Dormant Stem Treatment

Dormant stem treatments control susceptible woody plants and vines with stems less than 2 inches in diameter. Plants with stems greater than 2 inches in diameter may not be controlled and resprouting may occur. This treatment method is best suited for sites with dense, small diameter brush. Dormant stem treatments of Garlon 4 can also be used as a chemical side-trim for controlling lateral branches of larger trees that encroach onto roadside, utility, or other rights-of-way.

Mix 4 to 8 quarts of Garlon 4 in 2 to 3 gallons of crop oil concentrate or other recommended oil and add this mixture in enough water to make 100 gallons of spray solution. Use continuous adequate agitation. Apply with knapsack or power spraying equipment, using low pressure (20 to 40 psi). In western states, apply anytime after woody plants are dormant and most of the foliage has dropped. In other areas apply anytime within 10 weeks of budbreak, generally February through April. Thoroughly wet the upper parts of the stems and use the remainder to wet the lower 12 to 15 inches above the ground to the point of runoff. For root suckering species such as sumac, sassafras and locust, also spray the ground under the plant to cover small root suckers which may not be visible above the soil surface. For oil-water mixture application, mix 6 quarts of Garlon 4, 25 gallons of oil and 1.5 gallons of an approved agricultural spray emulsifier such as Sponto 712 or Triton X-100 as indicated in the mixing directions. Treat as above. Garlon 4 may be mixed with 4 quarts of Weedone 170 herbicide to improve the control of black cherry and broaden the spectrum of herbicidal activity. Do not apply to wet or saturated bark as poor control may result.

Cut Stump Treatment

To control resprouting, mix 20 to 30 gallons of Garlon 4 in enough oil to make 100 gallons of spray mixture. Apply with a backpack or knapsack sprayer using low pressures and a solid cone or flat fan nozzle. Spray the root collar area, sides of the stump, and the outer portion of the cut surface, including the cambium, until thoroughly wet, but not to the point of runoff. Spray mixture concentration should vary with the size and susceptibility of species treated. Apply anytime, including in winter months, except when snow or water prevent spraying to the ground line. **Mixing with oil requires vigorous agitation to form an oil solution.** Once a solution is formed it will stay stable.

Cut Stump Treatment in Western States

To control resprouting of salt cedar and other *Tamarix* species, bigleaf maple, tanoak, Oregon myrtle, and other susceptible species, apply undiluted Garlon 4 to wet the cambium and adjacent wood around the entire circumference of the cut stump. Treatments may be applied throughout the year; however, control may be reduced with treatment during periods of moisture stress as in late summer. Cut stumps so that they are approximately level to facilitate uniform coverage of Garlon 4. Use an applicator which can be calibrated to deliver the small amounts of material required.

Growing Point and Leaf Base (Crown) Treatment of Yucca

Prepare a 2% v/v solution of Garlon 4 in diesel or fuel oil (13 fl oz of Garlon 4 in 5 gallons of spray mixture). Thoroughly wet the center of the plant including growing point and leaf bases to the soil surface. Complete coverage of leaves is not necessary.

Forest Management Applications

For broadcast applications, apply 1 to 6 quarts of Garlon 4 per acre in a total spray volume of 5 to 25 gallons per acre by air or 10 to 100 gallons per acre by ground. Use spray volumes sufficient to provide thorough coverage of treated foliage. Nozzles or additives that produce larger droplets of spray may require higher spray volumes to provide adequate coverage.

Plant Back Interval for Conifers: Conifers planted sooner than 1 month after treatment with Garlon 4 at less than 4 quarts per acre or sooner than 2 months after treatment at 4 to 6 quarts per acre may be injured. When tank mixtures of herbicides are used for forest site preparation, labels for all products in the mixture should be consulted and the longest recommended waiting period before planting observed.

Forest Site Preparation (Not for Conifer Release)

Southern States including Alabama, Arkansas, Delaware, Florida, Georgia, Louisiana, Maryland, Mississippi, North Carolina, Oklahoma, South Carolina, Tennessee, Texas, and Virginia: To control susceptible woody plants and broadleaf weeds, apply Garlon 4 at a rate of 4 to 6 quarts per acre. To broaden the spectrum of woody plants and broadleaf weeds controlled, apply 2 to 4 quarts of Garlon 4 per acre in tank mix combination with labeled rates of Tordon 101 Mixture or Tordon K. Tordon 101 Mixture and Tordon K are not registered for use in the state of Florida. Where grass control is also desired, Garlon 4, alone or in tank mix combination with Tordon K or Tordon 101 Mixture, may be applied with labeled rates of other herbicides registered for grass control in forests. Use of tank mix products must be in accordance with the most restrictive of label limitations and precautions. Do not exceed labeled application rates. Garlon 4 cannot be tank mixed with any product containing a label prohibition against such mixing.

Western, Northeastern, North Central, and Lake States (States not Listed Above as Southern States): To control susceptible woody plants and broadleaf weeds, apply Garlon 4 at a rate of 3 to 6 quarts per acre. To broaden the spectrum of woody plants and broadleaf weeds controlled, apply 1.5 to 3 quarts of Garlon 4 per acre in tank mix combination with labeled rates of Tordon 101 Mixture, Tordon K, or 2,4-D low volatile ester. Tordon 101 Mixture and Tordon K are not registered for use in the state of California. Where grass control is also desired, Garlon 4, alone or in tank mix combination with Tordon 101 Mixture or Tordon K, may be applied with labeled rates of other herbicides registered for grass control in forests. When applying tank mixes, follow applicable use directions and precautions on each product label.

Southern Coastal Flatwoods: To control susceptible broadleaf weeds and woody species such as gallberry and wax-myrtle, and for partial control of saw-palmetto, apply 2 to 4 quarts of Garlon 4 per acre. To broaden the spectrum of species controlled to include fetterbush, staggerbush, liti, and grasses, apply 2 to 3 quarts of Garlon 4 per acre in tank mix combination with labeled rates of Arsenal Applicator's Concentrate herbicide. Where control of gallberry, wax-myrtle, broadleaf weeds, and grasses is desired, apply 2 to 3 quarts of Garlon 4 per acre in tank mix combination with labeled rates of Accord Concentrate or Accord SP herbicide.

These treatments may be broadcast during site preparation of flat planted or bedded sites or, on bedded sites, applied in bands over the top of beds. For best results, apply in late summer or fall. Efficacy may not be satisfactory when applications are made in early season prior to August. **Note:** Do not apply after planting pines.

Directed Spray Applications for Conifer Release

To release conifers from competing hardwoods and brush such as red maple, sugar maple, striped maple, sweetgum, red and white oaks, ash, hickory, alder, birch, aspen, pin cherry, *Ceanothus* spp., blackberry, chinquapin, and poison oak, mix 4 to 20 quarts of Garlon 4 in enough water to make 100 gallons of spray mixture. This spray mixture should be directed onto foliage of competitive hardwoods using knapsack or backpack sprayers with flat fan nozzles or equivalent anytime after the hardwoods and brush have reached full leaf size, but before autumn coloration. The majority of treated hardwoods and brush should be less than 6 feet in height to ensure adequate spray coverage. Care should be taken to direct spray away from contact with conifer foliage, particularly foliage of desirable pines. See Table 1 for relationship between mixing rate, spray volume and maximum application rate.

Note: Spray may cause temporary damage and growth suppression where contact with conifers occurs; however, injured conifers should recover and grow normally. Over-the-top spray applications can kill pines.

Broadcast Applications for Mid-Rotation Understory Brush Control in Southern Coastal Flatwoods Pine Stands (Ground Equipment Only)

For control of susceptible species such as gallberry and wax-myrtle and broadleaf weeds, apply 2 to 4 quarts of Garlon 4 per acre. To broaden the spectrum of woody plants controlled to include fetterbush, staggerbush, and liti, apply 2 to 3 quarts of Garlon 4 per acre in tank mix combination with labeled rates of Arsenal Applicator's Concentrate. Saw-palmetto will be partially controlled by use of Garlon 4 at 4 quarts per acre or by mixtures of Garlon 4 at 2 to 3 quarts per acre in tank mix combination with either Arsenal Applicator's Concentrate or Escort herbicide. These mixtures should be broadcast applied over target understory brush species, **but to prevent injury to pines, make applications underneath the foliage of pines.** Apply sprays in 30 gallons or more per acre of total volume. For best results, apply in late summer or fall. Efficacy may not be satisfactory when applications are made in early season prior to August.

Broadcast Applications for Conifer Release in the Pacific Northwest and California

Dormant Conifers Before Bud Swell (Excluding Pines): To control or suppress deciduous hardwoods such as vine maple, bigleaf maple, alder, scotch broom, or willow **before leaf-out**, or evergreen hardwoods such as madrone, chinquapin, and *Ceanothus* spp., use Garlon 4 at 1 to 2 quarts per acre. Use diesel or fuel oil as a diluent, or use water plus 1 to 2 gallons per acre of diesel oil or a suitable surfactant or oil substitute at manufacturer's recommended rates. **Mixing with oil as the only diluent requires vigorous agitation to form an oil solution.** Once a solution is formed it will stay stable.

Conifer Plantations (Excluding Pines) After Hardwoods Begin Growth and Before Conifer Bud Break ("Early Foliar" Hardwood Stage):

Use Garlon 4 at 1 to 1.5 quarts alone or with 2,4-D low volatile ester herbicide in water carrier to provide no more than 3 lb ae per acre from both products. After conifer bud break, these sprays may cause more serious injury to the crop trees. Use of a surfactant may cause unacceptable injury to conifers especially after bud break.

Conifer Plantations (Excluding Pines) After Conifers Harden Off in Late Summer and While Hardwoods are Still Actively Growing:

Use Garlon 4 at rates of 1 to 1.5 quarts per acre alone or with 2,4-D low volatile ester to provide no more than 3 lb ae per acre from both products. Treat as soon after conifer bud hardening as possible so that hardwoods and brush are actively growing. Use of oil, oil substitute, or surfactant may cause unacceptable injury to the conifers.

Broadcast Applications for Conifer Release in the Eastern United States

To release spruce, fir, red pine, and white pine from competing hardwoods such as red maple, sugar maple, striped maple, alder, birch (white, yellow, and grey), aspen, ash, pin cherry, and *Rubus* spp. and perennial and annual broadleaf weeds, use Garlon 4 at rates of 1.5 to 3 quarts per acre alone or with 2,4-D amine or low volatile ester to provide no more than 4 lb ae per acre from both products. Apply in late summer or early fall after conifers have formed their overwintering buds and hardwoods are in full leaf and prior to autumn coloration.

Broadcast Applications for Conifer Release in the Lake States Region

To release spruce, fir, and red pine from competing hardwoods such as aspen, birch, maple, cherry, willow, oak, hazel, and *Rubus* spp. and perennial and annual broadleaf weeds, use Garlon 4 at rates of 1.5 to 3 quarts per acre. Apply in late summer or early fall after conifers have formed their overwintering buds and hardwoods are in full leaf and prior to autumn coloration.

Terms and Conditions of Use

If terms of the following Warranty Disclaimer, Inherent Risks of Use, and Limitation of Remedies are not acceptable, return unopened package at once to the seller for a full refund of purchase price paid. Otherwise, use by the buyer or any other user constitutes acceptance of the terms under Warranty Disclaimer, Inherent Risks of Use and Limitation of Remedies.

Warranty Disclaimer

Dow AgroSciences warrants that this product conforms to the chemical description on the label and is reasonably fit for the purposes stated on the label when used in strict accordance with the directions, subject to the inherent risks set forth below. Dow AgroSciences MAKES NO OTHER EXPRESS OR IMPLIED WARRANTY OF MERCHANTABILITY OR FITNESS FOR A PARTICULAR PURPOSE OR ANY OTHER EXPRESS OR IMPLIED WARRANTY.

Inherent Risks of Use

It is impossible to eliminate all risks associated with use of this product. Plant injury, lack of performance, or other unintended consequences may result because of such factors as use of the product contrary to label instructions (including conditions noted on the label, such as unfavorable temperature, soil conditions, etc.), abnormal conditions (such as excessive rainfall, drought, tornadoes, hurricanes), presence of other materials, the manner of application, or other factors, all of which are beyond the control of Dow AgroSciences or the seller. All such risks shall be assumed by buyer.

Limitation of Remedies

To the extent permitted by law, the exclusive remedy for losses or damages resulting from this product (including claims based on contract, negligence, strict liability, or other legal theories), shall be limited to, at Dow AgroSciences' election, one of the following:

1. Refund of purchase price paid by buyer or user for product bought, or
2. Replacement of amount of product used.

To the extent permitted by law, Dow AgroSciences shall not be liable for losses or damages resulting from handling or use of this product unless Dow AgroSciences is promptly notified of such loss or damage in writing. To the extent permitted by law, in no case shall Dow AgroSciences be liable for consequential or incidental damages or losses.

The terms of the Warranty Disclaimer, Inherent Risks of Use, and Limitation of Remedies cannot be varied by any written or verbal statements or agreements. No employee or sales agent of Dow AgroSciences or the seller is authorized to vary or exceed the terms of the Warranty Disclaimer or this Limitation of Remedies in any manner.

[®]Trademark of Dow AgroSciences LLC

Produced for Dow AgroSciences LLC • Indianapolis, IN 46268 USA

Label Code: D02-102-026

Replaces Label: D02-102-025

LOES Number: 010-00085

EPA accepted 04/18/07

Revisions:

1. Product may be applied by fixed wing aircraft or helicopter.
2. Added mixing directions section.
3. Added blackbrush, granjeno, guajillo, guava, milkweed vine, osage orange, pepper vine, trumpet creeper, twisted acacia, Virginia creeper and willow primrose to list of woody plants controlled.
4. Added biennial broadleaf weeds to list of weeds controlled.
5. Added dormant stem and cut surface treatments.

MATERIAL SAFETY DATA SHEET



Emergency Phone: 800-992-5994
Dow AgroSciences LLC
Indianapolis, IN 46268

Effective Date: 17-Nov-06
Product Code: 38321
MSDS: 004422

GARLON* 3A HERBICIDE

1. PRODUCT AND COMPANY IDENTIFICATION:

PRODUCT: Garlon* 3A Herbicide

COMPANY IDENTIFICATION:

Dow AgroSciences LLC
9330 Zionsville Road
Indianapolis, IN 46268-1189

2. HAZARDOUS IDENTIFICATIONS:

EMERGENCY OVERVIEW

Light purple-pink liquid, ammonia-like odor. May cause eye irritation with corneal injury. May cause skin irritation. Toxic to aquatic organisms.

EMERGENCY PHONE NUMBER: 800-992-5994

3. COMPOSITION/INFORMATION ON INGREDIENTS:

COMPONENT	CAS NUMBER	W/W%
Triclopyr TEA Salt	057213-69-1	44.4
Triethylamine	000121-44-8	3.0
Ethanol	000064-17-5	2.1
Balance		50.5

4. FIRST AID:

EYES: Wash immediately and continuously with flowing water for at least 30 minutes. Remove contact lenses after the first 5 minutes and continue washing. Obtain prompt medical consultation, preferably from an ophthalmologist.

SKIN: Wash skin with plenty of water.

INGESTION: Do not induce vomiting. Give one cup (8 ounces or 240 ml) of water or milk if available and transport to a medical facility. Do not give anything by mouth to an unconscious person.

INHALATION: No emergency medical treatment necessary.

NOTE TO PHYSICIAN: Due to irritant properties, swallowing may result in burns/ulceration of mouth, stomach & lower gastrointestinal tract with subsequent stricture. Aspiration of vomitus may cause lung injury. Suggest endotracheal/esophageal control if lavage is done. If burn is present, treat as any thermal burn, after decontamination. Exposure to amine vapors may cause minor transient edema of the corneal epithelium (glaucompsia) with blurred vision, blue haze & halos around bright objects. Effects disappear in a few hours and temporarily reduce ability to drive vehicles. No specific antidote. Treatment of exposure should be directed at the control of symptoms and the clinical condition of the patient.

5. FIRE FIGHTING MEASURES:

FLASH POINT: 110°F (43°C)

METHOD USED: TCC

FLAMMABLE LIMITS

LFL: Not determined

UFL: Not determined

EXTINGUISHING MEDIA: Alcohol foam and CO₂.

FIRE & EXPLOSION HAZARDS: Toxic, irritating vapors may be formed or given off if product is involved in fire. Although product is water-based, it has a flash point due to the presence of small amounts of ethanol and triethylamine.

FIRE-FIGHTING EQUIPMENT: Use positive-pressure, self-contained breathing apparatus and full protective clothing.

6. ACCIDENTAL RELEASE MEASURES:

ACTION TO TAKE FOR SPILLS/LEAKS: Contain small spills and absorb with an inert material such as clay or dry sand. Report large spills to Dow AgroSciences at 800-992-5994.

7. HANDLING AND STORAGE:

PRECAUTIONS TO BE TAKEN IN HANDLING AND STORAGE: **HANDLING:** Keep out of reach of children. Causes irreversible eye damage. Harmful if inhaled or absorbed through skin. Prolonged or frequently repeated skin contact may cause allergic skin reaction in some individuals. Avoid contact with eyes, skin, clothing, breathing vapor, or spray mist. Users should wash hands before eating, drinking, chewing gum, using tobacco, or using the toilet.

MATERIAL SAFETY DATA SHEET



Emergency Phone: 800-992-5994
Dow AgroSciences LLC
Indianapolis, IN 46268

Effective Date: 17-Nov-06
Product Code: 38321
MSDS: 004422

GARLON* 3A HERBICIDE

STORAGE: Store above 28°F or agitate before use. Store in original container. See product label for handling/storage precautions relative to the end use of this product.

8. EXPOSURE CONTROLS/PERSONAL PROTECTION:

These precautions are suggested for conditions where the potential for exposure exists. Emergency conditions may require additional precautions.

EXPOSURE GUIDELINE(S):

Ethanol (ethyl alcohol): ACGIH TLV and OSHA PEL are 1000 ppm. ACGIH classification is A4.
Triclopyr TEA Salt: Dow AgroSciences Industrial Hygiene Guideline is 2 mg/M³ as acid equivalent; Skin.
Triethylamine: ACGIH TLV is 1 ppm TWA, 3 ppm STEL, Skin. OSHA PEL is 10 ppm TWA, 15 ppm STEL.

A "skin" notation following the exposure guideline refers to the potential for dermal absorption of the material including mucous membranes and the eyes either by contact with vapors or by direct skin contact. It is intended to alert the reader that inhalation may not be the only route of exposure and that measures to minimize dermal exposures should be considered.

ENGINEERING CONTROLS: Provide general and/or local exhaust ventilation to control airborne levels below the exposure guidelines.

RECOMMENDATIONS FOR MANUFACTURING, COMMERCIAL BLENDING, AND PACKAGING WORKERS:

EYE PROTECTION: Use chemical goggles. Eye wash fountain should be located in immediate work area. If exposure causes eye discomfort, use a full-face respirator.

SKIN PROTECTION: When prolonged or frequently repeated contact could occur, use chemically protective clothing resistant to this material. Selection of specific items such as face shield, gloves, boots, and apron or full-body suit will depend on operation.

RESPIRATORY PROTECTION: Atmospheric levels should be maintained below the exposure guideline. When respiratory protection is required for certain operations, use a NIOSH approved air-purifying respirator.

APPLICATORS AND ALL OTHER HANDLERS: Refer to the product label for personal protective clothing and equipment.

9. PHYSICAL AND CHEMICAL PROPERTIES:

BOILING POINT: Not determined
VAPOR PRESSURE: Not determined
VAPOR DENSITY: Not applicable
SOLUBILITY IN WATER: Miscible
SPECIFIC GRAVITY: 1.135 (68/68°F)
APPEARANCE: Light purple/pink liquid
ODOR: Ammonia-like odor

10. STABILITY AND REACTIVITY:

STABILITY: (CONDITIONS TO AVOID) Avoid sources of ignition if temperature is near or above flash point.

INCOMPATIBILITY: (SPECIFIC MATERIALS TO AVOID) Any oxidizing agent. Consult manufacturer for specific cases.

HAZARDOUS DECOMPOSITION PRODUCTS: Nitrogen oxides and hydrogen chloride may be formed under fire conditions.

HAZARDOUS POLYMERIZATION: Not known to occur.

11. TOXICOLOGICAL INFORMATION:

POTENTIAL HEALTH EFFECTS: This section includes possible adverse effects, which could occur if this material is not handled in the recommended manner.

EYE: May cause severe irritation with corneal injury which may result in permanent impairment of vision, even blindness. Chemical burns may occur. Vapor of amines may cause swelling of the cornea resulting in visual disturbances such as blurred or hazy vision. Bright lights may appear to be surrounded by halos. Effects may be delayed and typically disappear spontaneously.

MATERIAL SAFETY DATA SHEET



Emergency Phone: 800-992-5994
Dow AgroSciences LLC
Indianapolis, IN 46268

Effective Date: 17-Nov-06
Product Code: 38321
MSDS: 004422

GARLON* 3A HERBICIDE

SKIN: Prolonged contact may cause skin irritation with local redness. Repeated contact may cause skin burns. Symptoms may include pain, severe local redness, swelling, and tissue damage. Prolonged or frequently repeated skin contact may cause allergic skin reactions in some individuals. With the dilute mix, no allergic skin reaction is expected. Prolonged skin contact is unlikely to result in absorption of harmful amounts. The LD₅₀ for skin absorption in rabbits is >5,000 mg/kg.

INGESTION: Low toxicity if swallowed. Small amounts swallowed incidentally as a result of normal handling operations are not likely to cause injury; however, swallowing larger amounts may cause injury. Swallowing may result in gastrointestinal irritation or ulceration. The oral LD₅₀ for rats is 2,574 mg/kg (male) and 1,847 mg/kg (female).

INHALATION: Brief exposure (minutes) is not likely to cause adverse effects.

SYSTEMIC (OTHER TARGET ORGAN) EFFECTS: Effects have been reported on the following organs: liver and kidney.

CANCER INFORMATION: Triclopyr did not cause cancer in laboratory animal studies.

TERATOLOGY (BIRTH DEFECTS): Triclopyr did not cause birth defects or other effects in the fetus even at doses which caused toxic effects in the mother. Ethanol has been shown to cause birth defects and toxicity to the fetus in laboratory animal tests. It has also been shown to cause human fetotoxicity and/or birth defects when ingested during pregnancy.

REPRODUCTIVE EFFECTS: For triclopyr, in laboratory animal studies, effects on reproduction have been seen only at doses that produced significant toxicity to the parent animals.

MUTAGENICITY: For triclopyr and ethanol: in-vitro genetic toxicity studies were negative. For triclopyr: animal genetic toxicity studies were negative. For ethanol: animal genetic toxicity studies were negative in some cases and positive in other cases.

12. ECOLOGICAL INFORMATION:

ENVIRONMENTAL FATE:

MOVEMENT & PARTITIONING:

Based largely or completely on information for triclopyr. Bioconcentration potential is low (BCF <100 or Log Pow <3).

DEGRADATION & PERSISTENCE:

Biodegradation under aerobic static laboratory conditions is high (BOD₂₀ or BOD₂₈/ThOD >40%).

The 20-Day biochemical oxygen demand (BOD₂₀) is 0.30 p/p.

Theoretical oxygen demand (ThOD) is calculated to be 0.75 p/p.

ECOTOXICOLOGY:

Material is slightly toxic to aquatic organisms on an acute basis (LC₅₀ or EC₅₀ is between 10 and 100 mg/L in most sensitive species).

13. DISPOSAL CONSIDERATIONS:

DISPOSAL METHOD: If wastes and/or containers cannot be disposed of according to the product label directions, disposal of this material must be in accordance with your local or area regulatory authorities. This information presented below only applies to the material as supplied. The identification based on characteristic(s) or listing may not apply if the material has been used or otherwise contaminated. It is the responsibility of the waste generator to determine the toxicity and physical properties of the material generated to determine the proper waste identification and disposal methods in compliance with applicable regulations. If the material as supplied becomes a waste, follow all applicable regional, national and local laws and regulations.

MATERIAL SAFETY DATA SHEET



Emergency Phone: 800-992-5994
Dow AgroSciences LLC
Indianapolis, IN 46268

Effective Date: 17-Nov-06
Product Code: 38321
MSDS: 004422

GARLON* 3A HERBICIDE

14. TRANSPORT INFORMATION:

U.S. DEPARTMENT OF TRANSPORTATION (DOT) INFORMATION:

For non-bulk shipments by land:
This material is not regulated for transport.

For bulk shipments by land:
COMBUSTIBLE LIQUID, N.O.S. (TRIETHYLAMINE,
ETHANOL)/COMBUSTIBLE LIQUID/NA1993/PGIII

For shipments by air or vessel:
FLAMMABLE LIQUIDS, N.O.S. (TRIETHYLAMINE,
ETHANOL)/3/UN1993/PGIII

15. REGULATORY INFORMATION:

NOTICE: The information herein is presented in good faith and believed to be accurate as of the effective date shown above. However, no warranty, express or implied, is given. Regulatory requirements are subject to change and may differ from one location to another; it is the buyer's responsibility to ensure that its activities comply with federal, state or provincial, and local laws. The following specific information is made for the purpose of complying with numerous federal, state or provincial, and local laws and regulations.

U.S. REGULATIONS

SARA 313 INFORMATION: This product contains the following substances subject to the reporting requirements of Section 313 of Title III of the Superfund Amendments and Reauthorization Act of 1986 and 40 CFR Part 372:

CHEMICAL NAME	CAS NUMBER	CONCENTRATION
Triethylamine	000121-44-8	3.0%

SARA HAZARD CATEGORY: This product has been reviewed according to the EPA "Hazard Categories" promulgated under Sections 311 and 312 of the Superfund Amendment and Reauthorization Act of 1986 (SARA Title III) and is considered, under applicable definitions, to meet the following categories:

An immediate health hazard
A delayed health hazard
A fire hazard

TOXIC SUBSTANCES CONTROL ACT (TSCA): All ingredients are on the TSCA inventory or are not required to be listed on the TSCA inventory.

STATE RIGHT-TO-KNOW: The following product components are cited on certain state lists as mentioned. Non-listed components may be shown in the composition section of the MSDS.

CHEMICAL NAME	CAS NUMBER	LIST
Ethanol	000064-17-5	NJ1 NJ3 PA1
Triethylamine	000121-44-8	NJ1 NJ3 PA1 PA3

NJ1=New Jersey Special Health Hazard Substance (present at > or = to 0.1%).

NJ3=New Jersey Workplace Hazardous Substance (present at greater than or equal to 1.0%).

PA1=Pennsylvania Hazardous Substance (present at > or = to 1.0%).

PA3=Pennsylvania Environmental Hazardous Substance (present at > or = to 1.0%).

OSHA HAZARD COMMUNICATION STANDARD: This product is a "Hazardous Chemical" as defined by the OSHA Hazard Communication Standard, 29 CFR 1910.1200.

NATIONAL FIRE PROTECTION ASSOCIATION (NFPA) RATINGS:

CATEGORY	RATING
Health	3
Flammability	2
Reactivity	0

COMPREHENSIVE ENVIRONMENTAL RESPONSE COMPENSATION AND LIABILITY ACT (CERCLA, or SUPERFUND): This product contains the following substance(s) listed as "Hazardous Substances" under CERCLA which may require reporting of releases:

Chemical Name	CAS Number	RQ	% in Product
Triethylamine	000121-44-8	5000	3.0%

MATERIAL SAFETY DATA SHEET



Emergency Phone: 800-992-5994
Dow AgroSciences LLC
Indianapolis, IN 46268

Effective Date: 17-Nov-06
Product Code: 38321
MSDS: 004422

GARLON* 3A HERBICIDE

RCRA Categorization Hazardous Code:
Triethylamine = U404

16. OTHER INFORMATION:

MSDS STATUS: Revised Section: 2, 3, 11, 12, 13, 15
Reference: DR-0121-6064
Replaces MSDS dated: 11/24/03
Document Code: D03-101-004
Replaces Document Code: D03-101-003

The Information Herein Is Given In Good Faith, But No
Warranty, Express or Implied, Is Made. Consult Dow
AgroSciences for Further Information.

*Trademark of Dow AgroSciences LLC

Clearcast®

Herbicide

SPECIMEN

SePRO

GROUP 2 HERBICIDE

FOR THE CONTROL OF VEGETATION IN AND AROUND AQUATIC AND NON-CROPLAND SITES INCLUDING AREAS THAT MAY BE GRAZED OR CUT FOR HAY

Active Ingredient:

ammonium salt of imazamox 2-[4,5-dihydro-4-methyl-4-(1-methylethyl)-5-oxo-1H-imidazol-2-yl]-5-(methoxymethyl)-3-pyridinecarboxylic acid 12.1%

Other Ingredients 87.9%

TOTAL 100.0%

Equivalent to 11.4% 2-[4,5-dihydro-4-methyl-4-(1-methylethyl)-5-oxo-1H-imidazol-2-yl]-5-(methoxymethyl)-3-pyridinecarboxylic acid
1 gallon contains 1.0 pound of active ingredient as the free acid

Keep Out of Reach of Children CAUTION/PRECAUCIÓN

Si usted no entiende la etiqueta, busque a alguien para que se la explique a usted en detalle. (If you do not understand this label, find someone to explain it to you in detail.)

See inside for complete Precautionary Statements, Directions for Use, Conditions of Sale and Warranty, and state-specific crop and/or use site restrictions.

Notice: Read the entire label before using. Use only according to label directions. Before buying or using this product, read Warranty Disclaimer and Misuse statements inside label booklet. If terms are unacceptable, return at once unopened.

EPA Reg. No. 241-437-67690
EPA Est. No. 067690-NIC-002
NVA 2016-04-299-0160

FPL20161026
166801

Manufactured for:
SePRO Corporation 11550 N. Meridian St., Ste. 600, Carmel, IN 46032, U.S.A.

Keep Out of Reach of Children CAUTION/PRECAUCIÓN

Si usted no entiende la etiqueta, busque a alguien para que se la explique a usted en detalle. (If you do not understand this label, find someone to explain it to you in detail.)

FIRST AID	
If on skin or clothing	<ul style="list-style-type: none">Take off contaminated clothing.Rinse skin immediately with plenty of water for 15 to 20 minutes.Call a poison control center or doctor for treatment advice.
If in eyes	<ul style="list-style-type: none">Hold eyes open and rinse slowly and gently with water for 15 to 20 minutes.Remove contact lenses, if present, after the first 5 minutes; then continue rinsing eyes.Call a poison control center or doctor for treatment advice.
If inhaled	<ul style="list-style-type: none">Move person to fresh air.If person is not breathing, call 911 or an ambulance; then give artificial respiration, preferably mouth to mouth if possible.Call a poison control center or doctor for further treatment advice.
HOTLINE NUMBER	
Have the product container or label with you when calling a poison control center or doctor or going for treatment. In case of an emergency endangering life or property involving this product, call INFOTRAC for emergency medical treatment information: 1-800-535-5053 .	

PRECAUTIONARY STATEMENTS

HAZARDS TO HUMANS AND DOMESTIC ANIMALS

CAUTION. Harmful if absorbed through skin or inhaled. Causes moderate eye irritation. Avoid breathing spray mist. Avoid contact with skin, eyes or clothing.

PERSONAL PROTECTIVE EQUIPMENT (PPE)

Applicators and other handlers must wear:

- Long-sleeved shirt and long pants;
- Chemical-resistant gloves such as barrier laminate, butyl rubber ≥ 14 mils, nitrile rubber ≥ 14 mils, neoprene rubber ≥ 14 mils, natural rubber (includes natural rubber blends and laminates) ≥ 14 mils, polyethylene, polyvinyl chloride (PVC) ≥ 14 mils, or Viton ≥ 14 mils;
- Shoes plus socks.

Follow manufacturer's instructions for cleaning and maintaining PPE. If no such instructions for washables exist, use detergent and hot water. Keep and wash PPE separately from other laundry.

USER SAFETY RECOMMENDATIONS

Users should:

- Wash hands before eating, drinking, chewing gum, using tobacco or using the toilet.
- Remove clothing/PPE immediately if pesticide gets inside. Then wash thoroughly and put on clean clothing.
- Remove PPE immediately after handling this product. Wash the outside of gloves before removing. As soon as possible, wash thoroughly and change into clean clothing.

ENVIRONMENTAL HAZARDS

This pesticide may be hazardous to plants outside the treated area. **DO NOT** apply to water except as specified in this label, **DO NOT** contaminate water when disposing of equipment washwaters and rinsate.

DIRECTIONS FOR USE

It is a violation of federal law to use this product in a manner inconsistent with its labeling. This labeling must be in the possession of the user at the time of pesticide application.

DO NOT apply this product in a way that will contact workers or other persons, either directly or through drift. Only protected handlers may be in the area during application. For any requirements specific to your state or tribe, consult the agency responsible for pesticide regulation.

Ensure spray drift to nontarget susceptible species does not occur.

DO NOT apply Clearcast® Herbicide in any manner not specifically described in this label.

Observe all cautions and limitations on this label and on the labels of products used in combination with Clearcast.

DO NOT use Clearcast other than in accordance with the instructions set forth on this label. Keep containers closed to avoid spills and contamination.

STORAGE AND DISPOSAL

DO NOT contaminate food, feed or water by storage or disposal.

Pesticide Storage

Keep from freezing. **DO NOT** store below 32°F.

Pesticide Disposal

Wastes resulting from the use of this product may be disposed of on-site or at an approved waste disposal facility.

Container Handling

Nonrefillable Container. DO NOT reuse or refill this container. Triple rinse or pressure rinse container (or equivalent) promptly after emptying; then offer for recycling, if available, or reconditioning, if appropriate, or puncture and dispose of in a sanitary landfill, or by incineration, or by other procedures approved by state and local authorities.

Triple rinse containers small enough to shake (capacity ≤ 5 gallons) as follows:

Empty the remaining contents into application equipment or a mix tank and drain for 10 seconds after the flow begins to drip. Fill the container ¼ full with water and recap. Shake for 10 seconds. Pour rinsate into application equipment or a mix tank, or store rinsate for later use or disposal. Drain for 10 seconds after the flow begins to drip. Repeat this procedure two more times.

Triple rinse containers too large to shake (capacity >5 gallons) as follows:

Empty the remaining contents into application equipment or a mix tank. Fill the container ¼ full with water. Replace and tighten closures. Tip container on its side and roll it back and forth, ensuring at least one complete revolution, for 30 seconds. Stand the container on its end and tip it back and forth several times. Turn the container over onto its other end and tip it back and forth several times. Empty the rinsate into application

STORAGE AND DISPOSAL (continued)

equipment or a mix tank, or store rinsate for later use or disposal. Repeat this procedure two more times.

Pressure rinse as follows: Empty the remaining contents into application equipment or mix tank and continue to drain for 10 seconds after the flow begins to drip. Hold container upside down over application equipment or mix tank, or collect rinsate for later use or disposal. Insert pressure rinsing nozzle in the side of the container and rinse at about 40 PSI for at least 30 seconds. Drain for 10 seconds after the flow begins to drip.

Refillable Container. Refill this container with pesticide only.

DO NOT reuse this container for any other purpose. Triple rinsing the container before final disposal is the responsibility of the person disposing of the container. Cleaning before refilling is the responsibility of the refiller.

Triple rinse as follows: To clean the container before final disposal, empty the remaining contents from this container into application equipment or mix tank. Fill the container about 10% full with water. Agitate vigorously or recirculate water with the pump for 2 minutes. Pour or pump rinsate into application equipment or rinsate collection system. Repeat this rinsing procedure two more times.

When this container is empty, replace the cap and seal all openings that have been opened during use; return the container to the point of purchase or to a designated location. This container must only be refilled with a pesticide product. Prior to refilling, inspect carefully for damage such as cracks, punctures, abrasions, worn-out threads and closure devices.

Check for leaks after refilling and before transport. **DO NOT** transport if this container is damaged or leaking. If the container is damaged, or leaking, or obsolete and not returned to the point of purchase or to a designated location, triple rinse emptied container and offer for recycling, if available, or dispose of container in compliance with state and local regulations.

IN CASE OF EMERGENCY

In case of large-scale spill of this product, call INFOTRAC at 1-800-535-5053.

In case of medical emergency regarding this product, call:

- Your local doctor for immediate treatment
- Your local poison control center (hospital)
- INFOTRAC: 1-800-535-5053

Steps to take if material is released or spilled:

- Dike and contain the spill with inert material (sand, earth, etc.) and transfer liquid and solid diking material to separate containers for disposal.
- Remove contaminated clothing, and wash affected skin areas with soap and water.
- Wash clothing before reuse.
- Keep the spill out of all sewers and open bodies of water.

PRODUCT INFORMATION

Clearcast® herbicide is an aqueous formulation that may be diluted in water and either applied directly to water for the control/suppression of certain submerged aquatic vegetation or applied as a broadcast or spot spray to floating and emergent vegetation. Aquatic sites that may be treated include estuarine and marine sites, ponds, lakes, reservoirs, wetlands, marshes, swamps, bayous, arroyos, ditches, canals, streams, rivers, creeks and other slow-moving or quiescent bodies of water. **Clearcast** may also be used during drawdown conditions. **Clearcast** may also be applied for terrestrial and riparian vegetation control in industrial noncropland sites, and railroad, utility, and highway rights-of-way. Industrial noncropland sites include utility plant sites, tank farms, pumping installations, storage areas, fence rows and ditch banks. **Clearcast** may also be used for the establishment and maintenance of wildlife openings. **Clearcast** may also be used on those sites listed above that may be grazed or cut for hay.

Clearcast is quickly absorbed by foliage and/or plant roots and rapidly translocated to the growing points stopping growth. Susceptible plants may develop a yellow appearance or general discoloration and will eventually die or be severely growth inhibited.

Clearcast is herbicidally active on many submerged, emergent and floating broadleaf and monocot aquatic plants. The relative levels of control and selectivity can be manipulated by using a choice of rates and herbicide placement (water injected or floating/emergent foliar application).

To help maintain the utility of herbicide programs, the use of herbicides with different modes of action is effective in managing weed resistance.

Spray Adjuvants

Applications of **Clearcast** to emergent, floating or shoreline species require the use of a spray adjuvant. Always use a spray adjuvant that is appropriate for aquatic sites.

Nonionic Surfactants - Use a nonionic surfactant at 0.25% volume/volume (v/v) or higher (see manufacturer's label) of the spray solution (0.25% v/v is equivalent to 1 quart in 100 gallons). For best results, select a nonionic surfactant with an HLB (hydrophilic to lipophilic balance) ratio between 12 and 17 with at least 70% surfactant in the formulated product (alcohols, fatty acids, oils, ethylene glycol or diethylene glycol should not be considered as surfactants to meet the above requirements).

Methylated Seed Oils or Vegetable Oil Concentrates - Instead of a surfactant, a methylated seed oil or vegetable-based seed oil concentrate may be used at 1.5 to 2 pints per acre. When using spray volumes greater than 30 gallons per acre, mix methylated seed oil or vegetable-based seed oil concentrates at 1% of the total spray volume, or alternatively use a nonionic surfactant as described above. Research indicates that these oils may aid in **Clearcast** deposition and uptake by plants under stress.

Silicone-based Surfactants - See manufacturer's label for specific rates. Silicone-based surfactants may reduce the surface tension of the spray droplet allowing greater spreading on the leaf surface as compared to conventional nonionic surfactants. However, some silicone-based surfactants may dry too quickly, limiting herbicide uptake.

Invert Emulsions - **Clearcast** can be applied as an invert emulsion. The spray solution results in an invert (water-in-oil) spray emulsion designed to minimize spray drift and spray runoff, resulting in more herbicide on the target foliage. The spray emulsion may be formed in a single tank (batch mixing) or injected (in-line mixing). Consult the invert chemical label for proper mixing directions.

Other - An antifoaming agent, spray pattern indicator, sinking agent or drift-reducing agent may be applied at the product labeled rate if necessary or desired.

Spray Drift Requirements for Aerial Application

- Applicators are required to use a coarse or coarser droplet size (ASABE S572) or, if specifically using a spinning atomizer nozzle, applicators are required to use a volume mean diameter (VMD) of 385 microns or greater for release heights below 10 feet. Applicators are required to use a very coarse or coarser droplet size or, if specifically using a spinning atomizer nozzle, applicators are required to use a VMD of 475 microns or greater for release heights above 10 feet. Applicators must consider the effects of nozzle orientation and flight speed when determining droplet size.
- Applicators are required to use upwind swath displacement.
- The boom length must not exceed 60% of the fixed wingspan or 90% of the rotor blade diameter to reduce spray drift.
- **DO NOT** apply when wind speed is greater than 10 mph.
- If applying at wind speeds less than 3 mph, the applicator must determine if
 1. Conditions of temperature inversion exist or
 2. Stable atmospheric conditions exist at or below nozzle height.

DO NOT make applications into areas of temperature inversions or stable atmospheric conditions.

Spray Drift Requirements for Ground Boom Application

- Applicators are required to use a nozzle height below 4 feet above the ground or plant canopy and coarse or coarser droplet size (ASABE S572) or, if specifically using a spinning atomizer nozzle, applicators are required to use a volume mean diameter (VMD) of 385 microns or greater.
- Applications with wind speeds greater than 10 mph are prohibited.
- Applications into temperature inversions are prohibited.

DO NOT apply when wind conditions may result in drift, when temperature inversion conditions exist, or when spray may be carried to sensitive areas. See *Managing Off-target Movement* section for more drift reduction recommendations.

AQUATIC USE DIRECTIONS

Clearcast® herbicide may be applied directly to the water for the control of submerged aquatic plant species and some emergent and floating species, or as a foliar application specifically for emergent and floating species.

DO NOT exceed maximum use rate per application:

- Water treatment - 500 parts per billion (ppb) (173 fl ozs of **Clearcast** per acre foot)
- Foliar broadcast application - 1 gallon per acre (1.0 lb ae/A)
- Foliar spot application - up to 5% **Clearcast** by volume

Clearcast may be applied by surface and aerial equipment including both fixed-wing aircraft and helicopter.

Foliar Application

Targeted Emergent and/or Floating Vegetation Application

To make surface applications targeting emergent or floating vegetation, uniformly apply with properly calibrated broadcast or spot treatment equipment in 10 or more gallons of water per acre. Spot treatments can be made with up to 5% **Clearcast** by volume. To ensure thorough spray coverage, higher spray volumes may be required when treating areas with large and/or dense vegetation. Use an appropriate spray pressure to minimize the drift potential depending upon spray equipment, conditions and application objectives.

Foliar Treatment of Emergent and Floating Vegetation Guidelines

- Always use a surfactant for foliar applications of emergent and floating weeds.
- Foliar applications of **Clearcast** may be made as a broadcast spray or as a spot spray with a percent spray solution ranging from 0.25% to 5% **Clearcast** by volume.
- Control will be reduced if spray is washed off foliage by wave action.

In aquatic sites, those application techniques described in the *Terrestrial Use Directions* section may be used to treat emergent vegetation.

Application to Water

Water Application to Target Submerged and/or Emergent/Floating Vegetation

Clearcast may be broadcast-applied to the water surface or injected below the water surface. **Clearcast** may be applied as undiluted product or diluted with water prior to application. Under surface-matted conditions, inject **Clearcast** below the water surface to achieve better product distribution.

Apply **Clearcast** to water to achieve a final concentration of the active ingredient of no more than 500 ppb. Multiple applications of **Clearcast** may be made during the annual growth cycle to maintain the desired vegetation response.

Average Water Depth of Treatment Site (feet)	Clearcast Rates Per Treated Surface Acre			
	Desired Active Ingredient Concentration (ppb) ¹			
	50	100	200	500
	Clearcast Rate per Treated Surface Acre (fl ozs)			
1	17	35	69	173
2	35	69	138	346
3	52	104	207	518
4	70	138	277	691
5	87	173	346	864
6	104	207	415	1,037
7	122	242	484	1,210
8	139	277	553	1,382
9	157	311	622	1,555
10	174	346	691	1,728

¹**Clearcast** contains 1.0 pound of active ingredient per gallon. There are 128 fl ozs in one gallon.

Aerial Application

Clearcast may be applied by both fixed-wing aircraft and helicopter. There is no minimum spray volume when making applications directly to the water. For applications targeting emergent and/or floating vegetation, uniformly apply with properly calibrated equipment in 5 or more gallons of water per surface acre. For best results, make aerial applications using a minimum of 20 gallons per acre.

Drawdown Application

Clearcast may be used in drawdown situations to provide postemergence and/or preemergence control/suppression of aquatic vegetation. Apply **Clearcast** as a broadcast spray at rates up to 1 gallon/A or as a spot spray treatment with up to 5% **Clearcast** by volume. Make applications when water has receded and exposed soil is moist to dry. For postemergence (foliar) applications, wait at least two weeks after application before reintroducing water. When treating irrigation canals, the initial flush of recharge water after application must not be used for irrigation purposes.

RESTRICTIONS

- **DO NOT** apply **Clearcast** to achieve a total active ingredient concentration in the water greater than 500 ppb.
- **DO NOT** apply more than 1 gallon of **Clearcast** per surface acre for the control of emergent and floating vegetation.

Irrigation Restrictions

- **DO NOT** use treated water to irrigate greenhouses, nurseries or hydroponics until the imazamox concentration has been determined by an acceptable method to be less than or equal to 1.0 ppb.
- **DO NOT** plant sugar beets, onions, potatoes or non-CLEARFIELD[®] canola in soils that have been previously irrigated with **Clearcast**-treated water until a soil bioassay successfully demonstrates acceptable levels of crop tolerance. The only exception to this restriction is if the water is from foliar applications to emergent and/or floating vegetation in flowing water sites where it has been applied at less than or equal to 1.5 quarts per acre to waters with an average depth of greater than or equal to 4 feet.
- **DO NOT** use **Clearcast**-treated waters resulting in a concentration greater than 50 ppb for irrigation of established (emerged) plants until residue levels have been shown to be less than or equal to 50 ppb by an acceptable method.
- **DO NOT** make **Clearcast** applications in and around golf course irrigation, sod farm irrigation, and vineyard irrigation waterbodies without testing potential irrigation water prior to irrigation and confirming the imazamox concentration to be less than or equal to 1.0 ppb.
- In still or quiescent waters, do not use **Clearcast**-treated water resulting in a concentration greater than 10 ppb for irrigation of newly seeded or newly established plants until residue levels have been shown to be less than or equal to 10 ppb by an acceptable method.
- Wait 24 hours before irrigating from still or quiescent waters after making a **Clearcast** application for submerged vegetation less than 100 feet from an irrigation intake.
- Wait 24 hours before irrigating from still and quiescent waters after making a **Clearcast** application to emergent and/or floating vegetation if greater than 25% of the surface area of the water body has been treated or application was made less than 100 feet from an irrigation intake.
- Flowing waters may be used to irrigate allowable sites with no restrictions when **Clearcast** is applied at less than or equal to 2 quarts per acre to waters with an average depth of greater than or equal to 4 feet.
- After application of **Clearcast** to dry irrigation canals/ditches, the initial flush of water during recharge must not be used for irrigation purposes unless the imazamox concentration has been determined by an acceptable method to be less than 25 ppb.

Clearcast applied at less than or equal to 2 quarts per acre in or on waters with a minimum average depth greater than or equal to 4 feet will result in **Clearcast** concentrations less than 50 ppb.

Other Water Use Restrictions

There are no restrictions on livestock watering, swimming, fishing, domestic use, or use of treated water for agricultural sprays.

Potable Water

Clearcast may be applied to potable water sources at concentrations up to 500 ppb to within a distance of ¼ mile from an active potable water intake. Within ¼ mile of an active potable water intake, **Clearcast** may be applied, but water concentrations resulting from injection and/or foliar applications may not exceed 50 ppb. If water concentrations greater than 50 ppb are required, the potable water intake must be shut and, if necessary, an alternate water supply be made available until the water concentration can be shown to be less than 50 ppb by an acceptable method.

Endangered Plant Species

To prevent potential negative impacts to endangered plant species, **DO NOT** apply **Clearcast** in a way that adversely affects federally listed endangered and threatened species.

WEEDS CONTROLLED OR SUPPRESSED BY CLEARCAST

Efficacy and selectivity of **Clearcast** is dependent upon many factors including: dose, time of year, stage of plant growth, plant susceptibility, method of application, and water movement. Rate selection will be partially dependent on characteristics of the treatment area and whether growth regulation or control is desired. Some areas may require a repeat application to control or suppress regrowth. Consult SePRO Corporation to determine best treatment protocols to manage individual species and to meet specific aquatic plant management objectives.

Emergent, Floating, and Shoreline Species Controlled with Foliar Application			
Common Name	Scientific Name	Rate (fl ozs/A)	Comments
Alligatorweed	<i>Alternanthera philoxeroides</i>	64 to 128	Repeat applications may be necessary. Add 1 qt/A of AquaPro® herbicide for quicker brownout.
American lotus	<i>Nelumbo lutea</i>	64 to 128	
Arrowhead	<i>Sagittaria</i> spp.	32 to 64	
Cattail	<i>Typha</i> spp.	32 to 64	Apply after full green up through killing frost.
Chinese tallowtree	<i>Sapium sebiferum</i>	64 to 128	
Common reed	<i>Phragmites</i> spp.	96 to 128	Use 1 qt/A methylated seed oil (MSO); apply in late vegetative stage up to killing frost. Also apply as a spot treatment using 1% to 2% Clearcast per spray volume. Older stands of phragmites and stands growing in water may be more difficult to control and will require follow-up applications.
Common salvinia	<i>Salvinia minima</i>	32 to 64	Apply with MSO or MSO + silicone-based surfactant; retreatment will be necessary.
Floating heart	<i>Nymphoides</i> spp.	64 to 128	Also apply as a spot treatment using 2% to 5% Clearcast and 1% MSO per spray volume.
Floating pennywort	<i>Hydrocotyle ranunculoides</i>	32 to 64	Repeat applications may be necessary.
Flowering rush	<i>Butomus umbellatus</i>	64 to 128	
Four-leaf clover	<i>Marsilea</i> spp.	32 to 64	
Frog's bit, Sponge plant	<i>Lymnobium</i> spp.	16 to 32	
Giant cane	<i>Arundo donax</i>	64 to 128	
Japanese knotweed	<i>Polygonum cuspidatum</i>	64 to 128	
Mexican lily	<i>Nymphaea mexicana</i>	32 to 64	
Mosquito fern	<i>Azolla</i> spp.	—	Apply using 2% to 5% Clearcast and 1% MSO by volume.
Parrotfeather	<i>Myriophyllum aquaticum</i>	64 to 128	Apply only to emergent vegetation.
Pickerelweed	<i>Pontederia cordata</i>	32 to 64	
Saltcedar	<i>Tamarix</i> spp.	64 to 128	Also apply using 2% to 5% Clearcast and 1% MSO per spray volume.
Smartweed, ladysthumb Smartweed, Pennsylvania Smartweed, swamp	<i>Polygonum persicaria</i> , <i>Persicaria maculosa</i> <i>Polygonum pensylvanicum</i> , <i>Persicaria pensylvanica</i> <i>Polygonum coccineum</i> , <i>Persicaria amphibia</i>	64 to 128	
Spatterdock	<i>Nuphar lutea</i>	64 to 128	
Variable-leaf milfoil	<i>Myriophyllum heterophyllum</i>	64 to 128	Apply with MSO (1% v/v) as an emergent foliar treatment when plants have emerged on the surface. Also apply as a spot treatment using 1% to 3% Clearcast per spray volume.
Water chestnut	<i>Trapa natans</i>	64 to 128	Apply with MSO to emergent part of plant. Also apply as a spot treatment using 2% to 5% Clearcast per spray volume.
Water hyacinth	<i>Eichhornia crassipes</i>	16 to 32	
Water lettuce	<i>Pistia stratiotes</i>	48 to 96	
Water lily	<i>Nymphaea</i> spp.	32 to 64	
Water primrose	<i>Ludwigia</i> spp.	32 to 64	Add 1 qt/A of AquaPro® herbicide for quicker brownout.
Watershield	<i>Brasenia schreberi</i>	48 to 64	
Wild taro	<i>Colocasia esculenta</i>	96 to 128	

Species Susceptible to Water-injected Applications

The following categories are provided to define species that may be growth regulated or controlled with 50 to 500 ppb **Clearcast® herbicide** following in-water applications: susceptible, moderately susceptible, and less susceptible. The rates associated with each susceptibility category, including the **Special Weed Control** section, are provided as guidance with the overriding allowance that an application rate from 50 to 500 ppb may be used depending on the aquatic vegetation management objective and the characteristics of the aquatic vegetation and water body being treated.

Some species that are susceptible to foliar applications of **Clearcast** may be less susceptible to in-water applications. Use of higher rates are necessary to achieve desired control/suppression in areas of greater water exchange; when treating more mature or less susceptible plants; when targeting more difficult-to-control aquatic species; and when treating small areas in larger

bodies of water (partial or spot treatments). Lower concentrations are generally used when conducting early season large-scale treatments; when greater selectivity is desired; and treating larger areas, more immature or susceptible plants, and areas with less potential for rapid water exchange.

Use of lower rates may increase selectivity on some species within the same category. Effects on susceptible plants can range from control to growth regulation depending on treatment site characteristics, exposure time, and application rate. Susceptible plant species may exhibit herbicide stress or reduced growth during active treatment phases. Whole lake applications with lower rates may provide plant growth regulation or greater selectivity while higher rates will generally provide broader activity.

Susceptible Vascular Aquatic Plants (50 to 200 ppb)

Common Name	Scientific Name
Curlyleaf pondweed	<i>Potamogeton crispus</i>
Eurasian watermilfoil	<i>Myriophyllum spicatum</i>
Hydrilla	<i>Hydrilla verticillata</i>
Sago pondweed	<i>Stuckenia pectinata</i>
Water hyacinth	<i>Eichhornia crassipes</i>
Water stargrass	<i>Heteranthera dubia</i>

Moderately Susceptible Vascular Aquatic Plants (100 to 300 ppb)

Common Name	Scientific Name
American pondweed	<i>Potamogeton nodosus</i>
Bladderwort	<i>Utricularia</i> spp.
Frog's bit	<i>Lymnobia spongia</i>
Illinois pondweed	<i>Potamogeton illinoensis</i>
Pickerelweed	<i>Pontederia cordata</i>
Salvinia	<i>Salvinia</i> spp.
Spikerush	<i>Eleocharis baldwinii</i>
Variable-leaf milfoil	<i>Myriophyllum heterophyllum</i>
Wigeon grass	<i>Ruppia maritima</i>

Less Susceptible Vascular Aquatic Plants (200 to 500 ppb)

Common Name	Scientific Name
Bulrush	<i>Schoenoplectus californicus</i>
Cattail	<i>Typha</i> spp.
Coontail	<i>Ceratophyllum demersum</i>
Eelgrass, Japanese	<i>Zostera japonica</i>
Egeria	<i>Egeria densa</i>
Flowering rush	<i>Butomus umbellatus</i>
Southern naiad	<i>Najas guadalupensis</i>
Spatterdock	<i>Nuphar lutea</i>
Water lily	<i>Nymphaea odorata</i>
Watershield	<i>Brasenia schreberi</i>

Special Weed Control

Eurasian Watermilfoil. Apply Clearcast herbicide at 100 to 200 ppb to actively growing plants early in the growing season. Applications made to mature Eurasian watermilfoil (vegetation topped out) may require multiple applications.

Hydrilla. Apply Clearcast at 150 to 200 ppb to actively growing plants early in the growing season. Applications made prior to topped-out hydrilla may require repeat application. A single application of 50 to 75 ppb can be used to suppress and growth-regulate hydrilla for up to 10 to 12 weeks. If desired, an additional 50 to 75 ppb can be applied to extend the period of growth suppression when normal hydrilla growth resumes.

Japanese Eelgrass. Japanese eelgrass is a submerged aquatic plant which can be found in tidal and intertidal areas. Clearcast herbicide may be applied directly to the water or directly to the plant (e.g. at low tide).

• **Low-tide application** - To make applications when the plant is exposed at low tide, uniformly apply with properly calibrated broadcast or spot treatment equipment in 10 or more gallons of water per acre. An appropriate spray adjuvant approved for aquatic use may be used but is not required. Spot treatments can be made with up to 5% Clearcast by volume. To ensure thorough spray coverage, higher spray volumes may be required when treating areas with large and/or dense vegetation. Use an appropriate spray pressure to minimize drift potential depending upon spray equipment, conditions, and application objectives. Apply 4 fl ozs to 32 fl ozs Clearcast/A. Use the lower rate for management of seedlings. An appropriate aquatic use spray adjuvant may be used but is not required.

• **In-water application** - When Japanese eelgrass is submerged, Clearcast may be broadcast-applied to the water surface or injected below the water surface. Clearcast may be applied as undiluted product or diluted with water before application. Under surface-matted conditions, inject Clearcast below the water surface to achieve better product distribution. Apply Clearcast to water to achieve a final concentration of the active ingredient of no more than

500 ppb. Multiple applications of Clearcast may be made during the annual growth cycle to maintain the desired vegetation response.

Sago Pondweed. In dry ditches (drainage and irrigation), sago pondweed may be controlled or growth-suppressed with soil-applied Clearcast at 64 to 128 fl ozs/A. In irrigation canals, apply Clearcast after drawdown and prior to water recharge.

TERRESTRIAL USE DIRECTIONS

Restrictions

- The maximum amount of active ingredient that can be applied is 1 gallon (equivalent to 1 pound of active ingredient as the free acid) per acre per year.
- DO NOT** exceed 2 applications of Clearcast per year.

Clearcast may be applied with ground and aerial equipment including both fixed-wing aircraft and helicopter. Applications may be made using foliar broadcast spray, foliar spot spray, injection (hack and squirt), frill and girdle, cut stump, or basal methods.

Broadcast Spray Application

DO NOT apply more than 1 gallon of Clearcast per acre per year.

Foliar Spot Application

Apply Clearcast as a percent solution, containing up to 5% Clearcast by volume.

Injection (Hack and Squirt), Frill and Girdle, and Cut Stump Application

Treatments may be made using up to 100% Clearcast by volume.

Basal Application

Treatments can be made using up to 25% Clearcast by volume. Basal applications require the use of a good emulsion system to maintain Clearcast in a stable emulsion with the penetrating agent being used.

All foliar applications of Clearcast require the use of a spray adjuvant. Refer to *Spray Adjuvants* section for additional information.

Managing Off-target Movement

The following information is general guidance for managing and minimizing off-target exposure of this product. Specific use directions in this label may vary from these general guidelines depending on the application method and objectives and should supersede the information provided below.

Avoiding spray drift at the application site is the responsibility of the applicator. The interaction of many equipment-related and weather-related factors determines the potential for spray drift. The applicator and the grower are responsible for considering all these factors when making decisions.

The following drift management requirements must be followed to avoid off-target drift movement from aerial applications:

- The distance of the outermost nozzles on the boom must not exceed $\frac{1}{4}$ the length of the fixed wingspan or 90% of rotor blade diameter.
- Nozzles must always point backward parallel with the airstream and never be pointed downward more than 45 degrees.
- DO NOT** apply if wind speed is greater than 10 mph, except when making injection or subsurface applications to water.

Where states have more stringent regulations, they must be observed.

The applicator must be familiar with and take into account the information covered in the following aerial drift reduction advisory information.

Information on Droplet Size

The most effective way to reduce drift potential is to apply large droplets. The best drift management strategy is to apply the largest droplets that provide sufficient coverage and control. Applying larger droplets reduces drift potential but will not prevent drift if applications are made improperly or under unfavorable environmental conditions (see *Wind; Temperature and Humidity; and Temperature Inversions*).

Controlling Droplet Size:

- Volume** - Use high flow rate nozzles to apply the highest practical spray volume. Nozzles with higher rated flows produce larger droplets.
- Pressure** - **DO NOT** exceed the nozzle manufacturer's recommended pressures. For many nozzle types, lower pressure produces larger droplets. When higher flow rates are needed, use higher flow rate nozzles instead of increasing pressure.
- Number of Nozzles** - Use the minimum number of nozzles that provides uniform coverage.

- **Nozzle Orientation** - Orienting nozzles so that the spray is released parallel to the airstream produces larger droplets than other orientations and is recommended practice. Significant deflection from the horizontal will reduce droplet size and increase drift potential.
- **Nozzle Type** - Use a nozzle type that is designed for the intended application. With most nozzle types, narrower spray angles produce larger droplets. Consider using low-drift nozzles. Solid-stream nozzles oriented straight back produce the largest droplets and the lowest drift.

Boom Length

For some use patterns, reducing the effective boom length to less than ¾ of the fixed wingspan or 90% of rotor blade diameter may further reduce drift without reducing swath width.

Application Height

Applications must not be made at a height greater than 10 feet above the top of the largest plants unless a greater height is required for aircraft safety. Making applications at the lowest height that is safe reduces exposure of droplets to evaporation and wind.

Swath Adjustment

When applications are made with a crosswind, the swath will be displaced downwind. Therefore, on the upwind and downwind edges of the field, the applicator must compensate for this displacement by adjusting the path of the aircraft upwind. Swath adjustment distance should increase with increasing drift potential (higher wind, smaller droplets, etc.).

Wind

Drift potential is lowest between wind speeds of 2 to 10 mph. However, many factors, including droplet size and equipment type, determine drift potential at any given speed. Application must be avoided below 2 mph due to variable wind direction and high inversion potential.

NOTE: Local terrain can influence wind patterns. Every applicator must be familiar with local wind patterns and how they affect spray drift.

Temperature and Humidity

When making applications in low relative humidity, set up equipment to produce larger droplets to compensate for evaporation. Droplet evaporation is most severe when conditions are both hot and dry.

Temperature Inversions

Applications must not occur during a temperature inversion because drift potential is high. Temperature inversions restrict vertical air mixing that causes small suspended droplets to remain in a concentrated cloud. This cloud can move in unpredictable directions due to the light, variable winds common during inversions. Temperature inversions are characterized by increasing temperatures with altitude and are common on nights with limited cloud cover and light-to-no wind. They begin to form as the sun sets and often continue into the morning. Their presence can be indicated by ground fog; however, if fog is not present, inversions can also be identified by the movement of smoke from a ground source or an aircraft smoke generator. Smoke that layers and moves laterally in a concentrated cloud (under low wind conditions) indicates an inversion, while smoke that moves upward and rapidly dissipates indicates good vertical air mixing.

Sensitive Areas

The pesticide must only be applied when the potential for drift to adjacent sensitive areas (e.g. residential areas, bodies of water, known habitat for threatened or endangered species, or crops) is minimal (e.g. when wind is blowing away from the sensitive areas).

To the extent consistent with the applicable law, applicator is responsible for any loss or damage which results from spraying **Clearcast** in a manner other than directed in this label. In addition, applicator must follow all applicable state and local regulations and ordinances in regard to spraying.

Clearcast may be used for the control of the following plant species. **Clearcast** may be effective for the control or suppression of additional plant species not listed below. The use of **Clearcast** for the control or suppression of undesirable plants not listed below may be done at the discretion of the user.

To the extent consistent with applicable law, the user assumes responsibility for any lack of control or suppression associated with application to weeds not listed on this label.

Common Name	Scientific Name	Weeds Controlled	
		Rate Foliar (fl ozs/A)	Comments
Alligator weed	<i>Alternanthera philoxeroides</i>	64 to 128	Addition of AquaPro® herbicide will improve efficacy.
Annual ryegrass	<i>Lolium multiflorum</i>	16 to 32	
Artichoke, Jerusalem	<i>Helianthus tuberosus</i>	64 to 128	
Bedstraw	<i>Galium aparine</i>	64 to 128	
Beet, wild	<i>Beta procumbens</i>	64 to 128	
Brazilian pepper* Christmasberry*	<i>Schinus terebinthifolius</i>	96 to 128	Also apply using 2% to 5% Clearcast per spray volume
Buckwheat, wild	<i>Polygonum convolvulus</i>	64 to 128	
Buttercup	<i>Ranunculus</i> spp.	64 to 128	
California bulrush*	<i>Schoenoplectus californicus</i>	64 to 128	
Camphor tree*	<i>Cinnamomum camphora</i>	2% to 5% v/v	
Canola, volunteer (non-Clearfield®)	<i>Brassica campestris</i> <i>Brassica napus</i>	64 to 128	
Cattail	<i>Typha</i> spp.	32 to 64	
Chickweed, common	<i>Stellaria media</i>	64 to 128	
Chinese tallowtree; Popcorn tree	<i>Sapium sebiferum</i>	64 to 128	See Special Weed Control section.
Cocklebur, common	<i>Xanthium strumarium</i>	64 to 128	
Filaree, redstem Filaree, whitestem	<i>Erodium cicutarium</i> <i>Erodium moschatum</i>	64 to 128	
Flixweed	<i>Descurainia sophia</i>	64 to 128	
Giant ragweed**	<i>Ambrosia trifida</i>	32 to 64	
Henbit	<i>Lamium amplexicaule</i>	64 to 128	
Jamaican nightshade*	<i>Solanum jamaicense</i>	2% to 5% v/v	
Japanese stiltgrass	<i>Microstegium vimineum</i>	32 to 64	Use MSO at 1% by spray volume. Clearcast will provide some residual control of subsequent seedling emergence.
Jimsonweed	<i>Datura stramonium</i>	64 to 128	

continued

Weeds Controlled (continued)			
Common Name	Scientific Name	Rate Foliar (fl ozs/A)	Comments
Johnsongrass, rhizome Johnsongrass, seedling	<i>Sorghum halepense</i>	32 to 64 16 to 32	
Knotweed, prostrate	<i>Polygonum aviculare</i>	64 to 128	
Kochia	<i>Kochia scoparia</i>	64 to 128	
Lambsquarters, common	<i>Chenopodium album</i>	64 to 128	
Lettuce, miner's	<i>Montia perfoliata</i>	64 to 128	
Mallow, common Mallow, Venice	<i>Malva neglecta</i> <i>Hibiscus trionum</i>	64 to 128	
Mustard spp.	<i>Brassica</i> spp.	64 to 128	
Nettle, burning	<i>Urtica urens</i>	64 to 128	
Nettleleaf goosefoot	<i>Chenopodium murale</i>	64 to 128	
Nightshade, black Nightshade, Eastern black Nightshade, hairy	<i>Solanum nigrum</i> <i>Solanum ptycanthum</i> <i>Solanum sarrachoides</i>	64 to 128	
Old world climbing fern*	<i>Lygodium microphyllum</i>	5% v/v	
Pennycress, field	<i>Thlaspi arvense</i>	64 to 128	
Phragmites*	<i>Phragmites australis</i>		Use 1 qt/A methylated seed oil (MSO); apply in late vegetative stage up to killing frost. Also apply as a spot treatment using 1% to 2% Clearcast per spray volume. Older stands of phragmites and stands growing in water may be more difficult to control and will require follow-up applications.
Pigweed, prostrate Pigweed, redroot Pigweed, smooth Pigweed, spiny	<i>Amaranthus blitoides</i> <i>Amaranthus retroflexus</i> <i>Amaranthus hybridus</i> <i>Amaranthus spinosus</i>	64 to 128	
Puncturevine	<i>Tribulus terrestris</i>	64 to 128	
Purple loosestrife*	<i>Lythrum salicaria</i>	32 to 64	
Purslane, common	<i>Portulaca oleracea</i>	64 to 128	
Radish, wild	<i>Raphanus raphanistrum</i>	64 to 128	
Ragweed, common Ragweed, giant	<i>Ambrosia artemisiifolia</i> <i>Ambrosia trifida</i>	64 to 128	
Rocket, London Rocket, yellow	<i>Sisymbrium irio</i> <i>Barbarea vulgaris</i>	64 to 128	
Saltcedar*	<i>Tamarix</i> spp.	64 to 128	Also apply using 2% to 5% Clearcast and 1% MSO per spray volume.
Sedge*, purple Sedge*, yellow	<i>Cyperus rotundus</i> <i>Cyperus esculentus</i>	32 to 64	Also apply using 2% to 5% Clearcast per spray volume.
Shepherd's-purse	<i>Capsella bursa-pastoris</i>	64 to 128	
Smartweed, ladythumb Smartweed, Pennsylvania Smartweed, swamp	<i>Polygonum persicaria</i> , <i>Persicaria maculosa</i> <i>Polygonum pensylvanicum</i> , <i>Persicaria pensylvanica</i> <i>Polygonum coccineum</i> , <i>Persicaria amphibia</i>	64 to 128	
Spike rush*	<i>Eleocharis</i> spp.	64 to 128	
Spurge, prostrate	<i>Euphorbia maculata</i>	64 to 128	
Sunflower, common	<i>Helianthus annuus</i>	64 to 128	
Swinecress	<i>Coronopus didymus</i>	64 to 128	
Tansymustard, green	<i>Descurainia pinnata</i>	64 to 128	
Taro	<i>Taro</i> spp.	64 to 128 5% v/v	
Thistle, Russian	<i>Salsola iberica</i>	64 to 128	
Tropical soda apple*	<i>Solanum viarum</i>	2% to 5% v/v	
Water primrose	<i>Ludwigia</i> spp.	32 to 64	Addition of AquaPro® herbicide will improve efficacy.
Wetland nightshade*	<i>Solanum tampicense</i>	2% to 5% v/v	
Whitetop* Hoary cress*	<i>Cardaria draba</i>	8 to 16	
Willoweed panicle	<i>Epilobium brachycarpum</i>	64 to 128	
Velvetleaf	<i>Abutilon theophrasti</i>	64 to 128	

* Use not permitted in California unless otherwise directed by supplemental labeling

** Suppression of larger, well-established plants

In general, the use of methylated seed oil (MSO) at 1% v/v will provide the best control with foliar applications.

Special Weed Control - Chinese tallowtree

Clearcast at 64 to 128 fl ozs/A or 0.5 to 2.0% v/v may be applied as a foliar application for selective control of Chinese tallowtree in and around tolerant tree species. Control Chinese tallowtree with foliar applications using aerial, handgun, or backpack application methods. When treating Chinese tallowtree, ensure that application method and spray volume provide adequate coverage of targeted Chinese tallowtree plants. Add methylated seed oil at 32 fl ozs/A for broadcast applications, or at 1% v/v for spot backpack and handgun applications. Tolerant hardwood species may exhibit varying degrees of leaf discoloration and temporary injury.

Areas that may be Grazed or Cut for Hay

Apply **Clearcast** to listed aquatic and terrestrial noncrop sites that may be grazed or cut for hay at a maximum use rate of 1 gallon per acre of **Clearcast** or 5% (v/v) spray solution for spot treatments. There are no grazing or haying restrictions.

Warranty Disclaimer: SePRO Corporation warrants that this product conforms to the chemical description on the product label. Testing and research have also determined that this product is reasonably fit for the uses described on the product label. To the extent consistent with applicable law, SePRO Corporation makes no other express or implied warranty of fitness or merchantability nor any other express or implied warranty and any such warranties are expressly disclaimed.

Misuse: Federal law prohibits the use of this product in a manner inconsistent with its label directions. To the extent consistent with applicable law, the buyer assumes responsibility for any adverse consequences if this product is not used according to its label directions. In no case shall SePRO Corporation be liable for any losses or damages resulting from the use, handling or application of this product in a manner inconsistent with its label.

For additional important labeling information regarding SePRO Corporation's Terms and Conditions of Use, Inherent Risks of Use and Limitation of Remedies, please visit <http://www.seprolabels.com/terms/> or scan the image below.



©Copyright 2016 SePRO Corporation
Clearcast and Clearfield are registered trademarks of BASF.
AquaPro is a registered trademark of The Dow Chemical Company ("Dow") or an affiliated company of Dow.



SePRO Corporation
11550 North Meridian Street, Suite 600
Carmel, IN 46032, U.S.A.



SDS

Clearcast Herbicide

Conforms to HazCom 2012/United States

SAFETY DATA SHEET



Clearcast

Herbicide

Section 1. Identification

GHS product identifier: Clearcast Herbicide
Other means of identification: Not available.
EPA Registration No.: 241-437-67690

Supplier's details : SePRO Corporation
 11550 North Meridian Street
 Suite 600
 Carmel, IN 46032 U.S.A.
 Tel: 317-580-8282
 Toll free: 1-800-419-7779
 Fax: 317-580-8290
 Monday - Friday, 8am to 5pm
 E.S.T. www.sepro.com

Emergency telephone number (with hours of operation): INFOTRAC - 24-hour service 1-800-535-5053

The following recommendations for exposure controls and personal protection are intended for the manufacture, formulation and packaging of this product. For applications and/or use, consult the product label. The label directions supersede the text of this Safety Data Sheet for application and/or use.

Section 2. Hazards identification

According to Regulation 2012 OSHA Hazard Communication Standard; 29 CFR Part 1910.1200

Classification of the product: No need for classification according to GHS criteria for this product.

Label elements (Emergency overview) The product does not require a hazard warning label in accordance with GHS criteria.

Hazards not otherwise classified

Labeling of special preparations (GHS):

The following percentage of the mixture consists of components(s) with unknown hazards regarding the acute toxicity:

- 0 - 2 % dermal
- 0 - 2 % oral
- 15 - 18 % Inhalation - vapor
- 15 - 18 % Inhalation - mist

**Emergency overview**

According to Regulation 1994 OSHA Hazard Communication Standard; 29 CFR Part 1910.1200

CAUTION:
HARMFUL IF ABSORBED THROUGH SKIN.
HARMFUL IF INHALED.
KEEP OUT OF REACH OF CHILDREN.
KEEP OUT OF REACH OF DOMESTIC ANIMALS.
Avoid contact with the skin, eyes and clothing.
Avoid inhalation of mists/vapors.

Section 3. Composition/information on ingredients

According to Regulation 2012 OSHA Hazard Communication Standard; 29 CFR Part 1910.1200

CAS Number	Weight %	Chemical name
247057-22-3	12.1%	ammonium salt of imazamox (active ingredient)

Section 4. First aid measures**Description of first aid measures**

General advice: First aid providers should wear personal protective equipment to prevent exposure. Remove contaminated clothing. Move person to fresh air. If person is not breathing, call 911 or ambulance, then give artificial respiration, preferably mouth-to-mouth if possible. Call a poison control center or physician for treatment advice. Have the product container or label with you when calling a poison control center or doctor or going for treatment.

If inhaled: Remove the affected individual into fresh air and keep the person calm. Assist in breathing if necessary.

If on skin: Rinse skin immediately with plenty of water for 15 - 20 minutes.

If in eyes: Hold eyes open and rinse slowly and gently with water for 15 to 20 minutes. Remove contact lenses, if present, after first 5 minutes, then continue rinsing.

If swallowed: Have person sip a glass of water if able to swallow. Do not induce vomiting unless told to by a poison control center or doctor. Never induce vomiting or give anything by mouth if the victim is unconscious or having convulsions.

Most important symptoms and effects, both acute and delayed Symptoms: No significant reaction of the human body to the product known.

Indication of any immediate medical attention and special treatment needed

Note to physician Treatment: Symptomatic treatment (decontamination, vital functions).



Section 5. Fire-fighting measures

Extinguishing media	Suitable extinguishing media: Foam, dry powder, carbon dioxide, water spray
Special hazards arising from the substance or mixture	
Hazards during fire-fighting:	carbon monoxide, carbon dioxide, nitrogen oxide, nitrogen dioxide, Ammonium, Hydrocarbons, If product is heated above decomposition temperature, toxic vapours will be released. The substances/groups of substances mentioned can be released in case of fire.
Advice for fire-fighters	
Protective equipment for fire-fighting:	Firefighters should be equipped with self-contained breathing apparatus and turn-out gear.
Further information	Evacuate area of all unnecessary personnel. Contain contaminated water/firefighting water. Do not allow to enter drains or waterways.

Section 6. Accidental release measures

Personal precautions protective equipment and emergency procedures	Take appropriate protective measures. Clear area. Shut off source of leak only under safe conditions. Extinguish sources of ignition nearby and downwind. Ensure adequate ventilation. Wear suitable personal protective clothing and equipment.
Environmental precautions	Do not discharge into the subsoil/soil. Do not discharge into drains/surface waters/groundwater. Contain contaminated water/firefighting water.
Methods and material for containment and cleaning up	Dike spillage. Pick up with suitable absorbent material. Place into suitable containers for reuse or disposal in a licensed facility. Spilled substance/product should be recovered and applied according to label rates whenever possible. If application of spilled substance/product is not possible, then spills should be contained, solidified, and placed in suitable containers for disposal. After decontamination, spill area can be washed with water. Collect wash water for approved disposal.

Section 7. Handling and storage

Precautions for safe handling	RECOMMENDATIONS ARE FOR MANUFACTURING, COMMERCIAL BLENDING, AND PACKAGING WORKERS. PESTICIDE APPLICATORS & WORKERS must refer to the Product Label and Directions for Use attached to the product for Agricultural Use Requirements in accordance with the EPA Worker Protection Standard 40 CFR part 170. Ensure adequate ventilation. Provide good ventilation of working area (local exhaust ventilation if necessary). Keep away from sources of ignition - No smoking. Keep container tightly sealed. Protect contents from the effects of light. Protect against heat. Protect from air. Handle and open container with care. Do not open until ready to use. Once container is opened, content should be used as soon as possible. Avoid aerosol formation. Avoid dust formation. Provide means for controlling leaks and spills. Do not return residues to the storage containers. Follow label warnings
--------------------------------------	--



even after container is emptied. The substance/ product may be handled only by appropriately trained personnel. Avoid all direct contact with the substance/product. Avoid contact with the skin, eyes and clothing. Avoid inhalation of dusts/mists/vapors. Wear suitable personal protective clothing and equipment.

Protection against fire and explosion: The relevant fire protection measures should be noted. Fire extinguishers should be kept handy. Avoid all sources of ignition: heat, sparks, open flame. Sources of ignition should be kept well clear. Avoid extreme heat. Keep away from oxidizable substances. Electrical equipment should conform to national electric code. Ground all transfer equipment properly to prevent electrostatic discharge. Electrostatic discharge may cause ignition.

Conditions for safe storage, including any incompatibilities Segregate from incompatible substances. Segregate from foods and animal feeds. Segregate from textiles and similar materials.

Further information on storage conditions: Keep only in the original container in a cool, dry, well-ventilated place away from ignition sources, heat or flame. Protect containers from physical damage. Protect against contamination. The authority permits and storage regulations must be observed.

Storage stability: If substance/product crystallizes, thaw at room temperature.
Protect from temperatures below: 0 °C. Changes in the properties of the product may occur if substance/product is stored below indicated temperature for extended periods of time.
Protect from temperatures above: 40 °C. Changes in the properties of the product may occur if substance/product is stored above indicated temperature for extended periods of time.

Section 8. Exposure controls/personal protection

Users of a pesticidal product should refer to the product label for personal protective equipment requirements.

Advice on system design: Whenever possible, engineering controls should be used to minimize the need for personal protective equipment.

Personal protective equipment

RECOMMENDATIONS FOR MANUFACTURING, COMMERCIAL BLENDING, AND PACKAGING WORKERS:

Respiratory protection: Wear respiratory protection if ventilation is inadequate. Wear a NIOSH-certified (or equivalent) TC23C Chemical/Mechanical type filter system to remove a combination of particles, gas and vapours. For situations where the airborne concentrations may exceed the level for which an air purifying respirator is effective, or where the levels are unknown or Immediately Dangerous to Life or Health (IDLH), use NIOSH-certified full facepiece pressure demand self-contained breathing apparatus (SCBA) or a full facepiece pressure demand supplied-air respirator (SAR) with escape provisions.

Hand protection: Chemical resistant protective gloves, Protective glove selection must be based on the user's assessment of the workplace hazards.



SDS

Clearcast Herbicide

Eye protection:	Safety glasses with side-shields. Tightly fitting safety goggles (chemical goggles). Wear face shield if splashing hazard exists.
Body protection:	Body protection must be chosen depending on activity and possible exposure, e.g. head protection, apron, protective boots, chemical-protection suit.
General safety and hygiene measures:	Wear long sleeved work shirt and long work pants in addition to other stated personal protective equipment. Work place should be equipped with a shower and an eye wash. Handle in accordance with good industrial hygiene and safety practice. Personal protective equipment should be decontaminated prior to reuse. Gloves must be inspected regularly and prior to each use. Replace if necessary (e.g. pinhole leaks). Take off immediately all contaminated clothing. Store work clothing separately. Hands and/or face should be washed before breaks and at the end of the shift. No eating, drinking, smoking or tobacco use at the place of work. Keep away from food, drink and animal feeding stuffs.

Section 9. Physical and chemical properties

Form:	liquid
Odor:	acidic, mild
Odor threshold:	No data available.
Color:	pale, yellow, clear
pH value:	approx. 5 – 7 (20 °C)
Freezing point:	approx. 0 °C (1,013.3 hPa) Information applies to the solvent.
Boiling point:	approx. 100 °C (1,013.3 hPa) Information applies to the solvent.
Flash point:	A flash point determination is unnecessary due to the high water content.
Flammability:	Based on the structure or composition there is no indication of flammability
Lower explosion limit:	As a result of our experience with this product and our knowledge of its composition we do not expect any hazard as long as the product is used appropriately and in accordance with the intended use.
Upper explosion limit:	As a result of our experience with this product and our knowledge of its composition we do not expect any hazard as long as the product is used appropriately and in accordance with the intended use.
Autoignition:	Based on the water content the product does not ignite.
Vapor pressure:	approx. 23.3 hPa (20 °C) Information applies to the solvent.
Density:	1.0486 g/cm ³ (20 °C) 8.7510 Lb/USg (68 °F)
Vapour density:	not applicable
Partitioning coefficient	not applicable

n-octanol/water (log Pow):

Thermal decomposition: carbon monoxide, carbon dioxide, nitrogen oxide, nitrogen dioxide, Ammonium, Hydrocarbons
 Stable at ambient temperature. If product is heated above decomposition temperature toxic vapours may be released. If product is heated above decomposition temperature hazardous fumes may be released.

Viscosity, dynamic: 3.7 mPa.s (20 °C)

Solubility in water: soluble

Evaporation rate: not applicable

Molar mass: 320.4 g/mol

Other information: If necessary, information on other physical and chemical parameters is indicated in this section.

Section 10. Stability and reactivity

Reactivity

Additional information: No hazardous reactions if stored and handled as prescribed/indicated.

Corrosion to metals: Corrosive effects to metal are not anticipated.

Oxidizing properties: Not an oxidizer.

Chemical stability The product is stable if stored and handled as prescribed/indicated.

Possibility of hazardous reactions

Hazardous reactions: The product is chemically stable.
 No hazardous reactions if stored and handled as prescribed/indicated.

Conditions to avoid

Conditions to avoid: Avoid all sources of ignition: heat, sparks, open flame. Avoid electro-static charge. Avoid prolonged storage. Avoid contamination. Avoid prolonged exposure to extreme heat. Avoid extreme temperatures.

Incompatible materials

Substances to avoid: oxidizing agents

Hazardous decomposition products

Decomposition products: Hazardous decomposition products: No hazardous decomposition products if stored and handled as prescribed/indicated.

Thermal decomposition: Possible thermal decomposition products: carbon monoxide, carbon dioxide, nitrogen oxide, nitrogen dioxide, Ammonium, Hydrocarbons
 Stable at ambient temperature. If product is heated above decomposition temperature toxic vapours may be released. If product is heated above decomposition temperature hazardous fumes may be released.



Section 11. Toxicological information

Primary routes of exposure Routes of entry for solids and liquids are ingestion and inhalation, but may include eye or skin contact. Routes of entry for gases include inhalation and eye contact. Skin contact may be a route of entry for liquefied gases.

Acute Toxicity/Effects

Acute toxicity

Assessment of acute toxicity: Relatively nontoxic after single ingestion. Slightly toxic after short-term skin contact. Relatively nontoxic after short-term inhalation.
contact.

Product/ingredient name

Clearcast

Result

LC50 Inhalation Vapor
LD50 Dermal
LD50 Oral

Species

Rat
Rat
Rat

Dose

>5 mg/L
>4000 mg/kg
>5000 mg/kg

Exposure

4 hours
-
-

Irritation / corrosion

Assessment of irritating effects: May cause slight but temporary irritation to the eyes. May cause slight irritation to the skin. May cause moderate but temporary irritation to the eyes.

Product/ingredient name

Clearcast

Result

Eyes – non-irritant
Skin – non-irritant

Species

Rabbit
Rabbit

Score

-
-

Exposure

-
-

Observation

-
-

Sensitization

Assessment of sensitization: There is no evidence of a skin-sensitizing potential. modified Buehler test
Species: guinea pig
Result: Skin sensitizing effects were not observed in animal studies.

Chronic Toxicity/Effects

Repeated dose toxicity

Assessment of repeated dose toxicity: The product has not been tested. The statement has been derived from the properties of the individual components. No substance-specific organ toxicity was observed after repeated administration to animals.

Genetic toxicity

Assessment of mutagenicity: The product has not been tested. The statement has been derived from the properties of the individual components. Mutagenicity tests revealed no genotoxic potential.

Reproductive toxicity

Assessment of reproduction toxicity: The product has not been tested. The statement has been derived from the properties of the individual components. The results of animal studies gave no indication of a fertility impairing effect.

Teratogenicity

Assessment of teratogenicity: The product has not been tested. The statement has been derived from the properties of the individual components. Animal studies gave no indication of a developmental toxic effect at doses that were not toxic to the parental animals.

Other Information

Misuse can be harmful to health.

Symptoms of Exposure

No significant reaction of the human body to the product known.

Section 12. Ecological information

Toxicity

Aquatic toxicity

Assessment of aquatic toxicity:

There is a high probability that the product is not acutely harmful to aquatic organisms.

Aquatic plants

EC50 (72 h) > 100 mg/l (growth rate), *Pseudokirchneriella subcapitata*

Toxicity to fish

Information on: imazamox

LC50 (96 h) > 119 mg/l, *Lepomis macrochirus*

Aquatic plants

Information on: imazamox

EC10 (7 d) 0.0095mg/l, *Lemna gibba*
 EC50 (72 h) 29.1 mg/l (growth rate), *Pseudokirchneriella subcapitata*
 EC50 (7 d) 0.031 mg/l (growth rate), *Lemna gibba*

Assessment of terrestrial toxicity

With high probability not acutely harmful to terrestrial organisms.

Other terrestrial non-mammals

Information on: 3-Pyridinecarboxylic acid, 2-[4,5-dihydro-4-methyl-4-(1-methylethyl)-5-oxo-1Himidazol-2-yl]-5-(methoxymethyl)-

LC50, *Anas platyrhynchos*
 LD50 > 100 ug/bee, *Apis mellifera*

Persistence and degradability

Assessment biodegradation and elimination (H2O)

The product has not been tested. The statement has been derived from the properties of the individual components.

Elimination information

Not readily biodegradable (by OECD criteria).

Bioaccumulative potential

Assessment bioaccumulation potential

The product has not been tested. The statement has been derived from the properties of the individual components.

Mobility in soil

Assessment transport between environmental compartments

The product has not been tested. The statement has been derived from the properties of the individual components.

Information on: imazamox

The substance will not evaporate into the atmosphere from the water surface. Following exposure to soil, the product trickles away and can - dependant on degradation - be transported to deeper soil areas with larger water loads.

Additional information

Other ecotoxicological advice:

The ecological data given are those of the active ingredient. Do not release untreated into natural waters.



Section 13. Disposal considerations

Waste disposal of substance: Pesticide wastes are regulated. Improper disposal of excess pesticide, spray mix or rinsate is a violation of federal law. If pesticide wastes cannot be disposed of according to label instructions, contact the State Pesticide or Environmental Control Agency or the Hazardous Waste representative at the nearest EPA Regional Office for guidance.

Container disposal: Rinse thoroughly at least three times (triple rinse) in accordance with EPA recommendations. Consult state or local disposal authorities for approved alternative procedures such as container recycling. Recommend crushing, puncturing or other means to prevent unauthorized use of used containers.

RCRA: This product is not regulated by RCRA.

Section 14. Transport information

Land transport
USDOT Not classified as a dangerous good under transport regulations

Sea transport
IMDG Not classified as a dangerous good under transport regulations

Air transport
IATA/ICAO Not classified as a dangerous good under transport regulations

Section 15. Regulatory information

Federal Regulations

Registration status:

Chemical	TSCA, US	blocked / not listed
Crop Protection	TSCA, US	released / exempt

EPCRA 311/312 (Hazard categories): Refer to SDS section 2 for GHS hazard classes applicable for this product.

NFPA Hazard codes:

Health: 1	Fire: 0	Reactivity: 0	Special:
-----------	---------	---------------	----------

Labeling requirements under FIFRA

This chemical is a pesticide product registered by the Environmental Protection Agency and is subject to certain labeling requirements under federal pesticide law. These requirements differ from the classification criteria and hazard information required for safety data sheets, and workplace labels of non-pesticide chemicals. Following is the hazard information as required on the pesticide label.

CAUTION:
 HARMFUL IF ABSORBED THROUGH SKIN.
 HARMFUL IF INHALED.
 KEEP OUT OF REACH OF CHILDREN.
 KEEP OUT OF REACH OF DOMESTIC ANIMALS.



Avoid contact with the skin, eyes and clothing.

Section 16. Other information

SDS Prepared by:
SePRO Corporation
SDS Prepared on: 03/28/18

Notice to reader

To the best of our knowledge, the information contained herein is accurate. However, neither the above-named supplier, nor any of its subsidiaries, assumes any liability whatsoever for the accuracy or completeness of the information contained herein. Final determination of suitability of any material is the sole responsibility of the user. All materials may present unknown hazards and should be used with caution. Although certain hazards are described herein, we cannot guarantee that these are the only hazards that exist.

APPENDIX G

Spill Prevention Plan

OIL SPILL PREVENTION, CONTROL

AND

COUNTERMEASURE PLAN

FOR

**VEGITATION MANAGEMENT ALONG CHARLES RIVER
CHARLES RIVER RESERVATION, BOSTON MA**

PREPARED: AUGUST 28, 2021



Contents

INTRODUCTION.....	1
DESCRIPTION OF PROJECT	1
PLAN MAINTENANCE AND DISTRIBUTION	1
MOTOR VEHICLE ACCIDENTS.....	2
OIL AND HAZARDOUS INCIDENT REPORTING.....	2
NOTIFICATION OF RELEASES.....	4
RELEASES THAT REQUIRE NOTIFICATION TO MASSDEP	4
EMERGENCY PROCEDURES AND SAFETY PRECAUTIONS.....	5
EMERGENCY RESPONE FLOW CHART	5
GENERAL SPILL PROVISIONS	6
Minor Spill (< 10 GALLONS)	6
Large Spill (>10 GALLONS)	6
EMERGENCY CONTACTS	6
INJURIES AND ILLNESSES	7
FUEL AND OIL SPILLS.....	7
FIRES.....	7
WEATHER	8
OTHER EMERGENCIES (SECURITY, BOMB THREAT, CIVIL DISTURBANCE, ETC.).....	8
EMPLOYEE RESPONSIBILITIES	8
TRAINING	9
EMERGENCY TELEPHONE NUMBERS.....	9
ATTACHMENT A–ACCIDENT, SPILL & CONTAINMENT REPORTING FORM.....	10
Purpose	10
Scope.....	10
Responsibility	10
Procedure.....	10
Emergency Response Procedures.....	11

INTRODUCTION

This Oil Spill Prevention, Control and Countermeasure Plan (OSPCCP) has been developed by the Massachusetts Department of Conservation & Recreation (DCR) as a required supplement for DCR's Vegetation Management project along the Charles River to be conducted in Boston, Massachusetts (Project Site).

Approximate location:

Latitude: 42.3643 N

Longitude: 71.1378 W

The purpose of the Oil Spill Prevention, Control and Countermeasure Plan is to prepare DCR and their contractor and its employees for emergency situations which may occur. Typical emergencies for which we need to be prepared include spills and leaks, personal injuries, fires, weather-related emergencies and other situations which require operational response.

The content of this Oil Spill Prevention, Control and Countermeasure Plan includes:

- Descriptions of expected emergencies, their hazards, and the recommended plan of action to combat their effects.
- Procedures for reporting employee injuries, motor vehicle accidents, spills, product contamination or any other emergencies which may occur.
- Emergency contact phone numbers
- Decision making infrastructure with defined action steps that can be executed quickly.

DESCRIPTION OF PROJECT

In anticipation of the Head of the Charles, DCR is proposing to manage (trim) vegetation along the riparian buffer to provide views of the water for event spectators, organizers and emergency personnel (Project). As part of the Project, nuisance shrubs such as false indigo, and invasive shrubs and perennials growing along the riparian buffer will be trimmed to a minimum height of 18-inches from the Reservation's finished grade at an approximate width of 6-feet. Care will be used to minimize the possibility of trimmed vegetation falling into the River. Any vegetation that enters the River will be removed if it is safe to do so. Trimmed vegetation will be raked and stockpiled on the finished grade for removal and disposal upon completion of the activities and prior to the Head of the Charles

PLAN MAINTENANCE AND DISTRIBUTION

Copies of the Oil Spill Prevention, Control and Countermeasure Plan will be distributed as follows:

- DCR Project Manager
- Contractor Project Manager
- Contractor Field Managers

Designated recipients of the Oil Spill Prevention, Control and Countermeasure Plan will be offered training in the plan.

Requests for changes to Oil Spill Prevention, Control and Countermeasure Plan should be submitted in writing to the Project Safety Officer.

If there are any questions concerning changes to the plan, or if other revisions are required, contact the Project Safety Officer.

MOTOR VEHICLE ACCIDENTS

Immediate action steps:

1. Determine extent of the accident and any injuries.
2. If spill response assistance is required due to the size of the spill, location, or inability to immediately control it, or there is potential for the spill to impact the environment, immediately notify the Project Safety Officer who will then make the determination to contact our Insurance and/or Environmental Response Vendor.
3. Determine if immediate assistance is required at the accident scene that has not already been initiated (e.g. ambulance, police, tow truck, agency reporting, other vehicle to transfer cargo, etc.).
4. Verbally report accident to the Project Safety Officer.
5. Provide periodic feedback and/or status reports as often as required or necessary.
6. Should a motor vehicle accident result in personal injury, fatality, or any vehicle being towed or a product release to the ground, sewer, or navigable waterway, the Project Safety Officer will make an immediate verbal report to ownership.

OIL AND HAZARDOUS INCIDENT REPORTING

A "Hazardous Material Reportable Incident" is an occurrence during the course of transporting a hazardous material by truck, rail or air (including during loading, unloading and temporary storage) in which, as a direct result of the hazardous material:

- A person is killed;
- A person receives injuries requiring hospitalization;
- Estimated carrier or other property damage exceeds \$50,000 (excluding vehicle/property damage unless caused by the material/product itself);
- An evacuation of the general public occurs lasting one or more hours;
- One or more major transportation arteries or facilities are closed or shut down for one hour or more; or
- The operation, flight pattern or routine of an aircraft is altered.

Or

- A situation exists of such a nature (i.e., a continuing danger to life at the scene) that, in the judgment of the Project Safety Officer, should be reported even though it does not meet the criteria above.

Or

- An unintentional release of a hazardous material from a container (i.e., tank truck) caused by failure of the container or operator.

Incidents meeting the above definition(s) must be reported to the Project Safety Officer. If the incident meets any of the criteria in the first two paragraphs above, reporting must be immediate by telephone to the National Response Center (800-424-8802). The Project Safety Officer will make the report which will include the following information:

- Name of reporter;
- Name and address of the carrier represented by the reporter;
- Phone number where the reporter can be contacted;
- Date, time and location of the incident;
- Extent of injuries if any;
- Classification, name and quantity of hazardous material involved; and
- Type of incident and whether a continuing danger to life exists at the scene.

In the case of property damage greater than \$50,000, it may take some time to obtain estimates that are reliable and accurate enough to determine the total cost. If that's the only trigger for "immediate" reporting; telephonic notification, even days later, is acceptable. A telephone report must be followed within 30 days by a written report.

If the incident meets only the third item above, the report does not need to be immediate, but must be submitted in writing within 30 days of the incident.

Local Procedures: Field Staff must notify the Project Safety Officer for the following examples but not limited to these examples. Product spills, all motor vehicle accidents involving injuries significant property damage over one thousand dollars or if either vehicle is towed or if any party is taken to the hospital or if you are issued a citation, and any personal injury. **All spills regardless of quantity, must be reported immediately to the Project Safety Officer.**

Licensed Site Professional (LSP): A LSP has responsibility for issues associated with Oil and Hazardous Materials Releases that occur pursuant to Massachusetts Department of Environmental Protections (MassDEP) Massachusetts Contingency Plan (MCP) at 310 CMR 40.0000. The LSP is a hazardous waste consultant, as defined in M.G.L. C 21A paragraph 19 and holds a valid license issued by the Board of the Registration of Hazardous Waste Site Cleanup Professionals pursuant to M.G.L. C21A, paragraph 19-19J. In the event of a release of hazardous materials to soil or water, a LSP will be employed to provide necessary reporting to DEP or other appropriate regulatory agencies, and to coordinate any necessary site remediation activities.

The Licensed Site Professional (LSP) is required to provide the services necessary to comply with the requirements of the MCP. These services may include sampling, analysis and characterization of potentially contaminated media, preparation of Immediate Response Action (IRA) Plans, Utility-Related Abatement Measure (URAM) and Release Abatement Measure (RAM) Plans, Imminent Hazard Evaluations, status reports, transmittal forms, release notification forms, risk assessments, completion statements, and related documents required pursuant to the Massachusetts Contingency Plan (MCP).

The LSP shall evaluate soil and/or sediment with discoloration, odor, and presence of petroleum liquid or sheening on the groundwater surface, or any abnormal gas or materials in the ground which are known or suspected to be oil or hazardous materials.

NOTIFICATION OF RELEASES

The LSP is responsible for generating and submitting all soil tracking logs, daily field reports, analytical results, and MCP related reports (i.e. IRAs, URAMs, RAMs). These reports or logs will contain all field observations relevant to MCP issues, all data generated, and justification for all actions taken. The Contractor's LSP will be available to meet with DCR or its agents to discuss, clarify, or justify actions taken and data generated, and to accommodate comments or requests made by DCR or its agents.

RELEASES THAT REQUIRE NOTIFICATION TO MASSDEP

This section discusses release(s) that require notification to the MassDEP, as specified in 310 CMR 40.0310. If a 120-day reportable condition is encountered during characterization of soil that has not previously reported under RTN 3-1283. All work related to this "new" condition would be completed in accordance with requirements of the MCP. The Site is currently closed under the MCP and as such, reporting of a new release will only be required if a 2 or 72-hour condition is identified; or a contaminant not previously identified as a contaminant of concern is detected above reportable concentrations.

120-day notification conditions include, but are not limited to, the following:

- OHM detected in soil and/or groundwater at concentrations exceeding the applicable Reportable Concentrations
- The presence of Non-Aqueous Phase Liquid (NAPL) having a measured thickness equal to or greater than 1/8 inch and less than 1/2 inch.

A RAM, URAM, or other feasible MCP option, cannot be initiated or continued in the area where a two (2)-hour or seventy-two (72)-hour release or threat of release has been identified, as described in 310 CMR 40.0311 through 40.0314, until an Immediate Response Action (IRA) has been undertaken and an IRA Completion Statement has been submitted to the MassDEP. Remedial activities that are scheduled to take place in areas bordering other remedial area boundaries will be structured and monitored to assure they do not impact the conditions of other Remedial Activities.

Two (2)-hour notification conditions include, but are not limited to, the following:

- A release, or threat of release, of OHM over a 24-hour period that is equal to, greater than, or likely to be greater than, the MCP Reportable Quantity of that material
- Sudden release to water producing a sheen
- Release to a storm drain, or sanitary sewer posing an Imminent Hazard (as defined in 310 CMR 40.000)
- OHM detected in a private drinking water well at a concentration greater than or equal to the applicable MCP GW-1 RC.

Seventy-two (72)-hour notification conditions include, but are not limited to, the following:

- Identification of non-aqueous phase liquid (NAPL) on groundwater or surface water, with a thickness equal to or greater than 1/2 inches.
- OHM detected in the Zone I of a public water supply or within 500-feet of a private drinking water well at concentrations greater than or equal to the applicable MCP GW-1 Reportable Concentration
- Release or threat of release from an underground storage tank.

If these, or other conditions requiring two (2) or seventy-two (72)-hour notification, are found on-site it is Newport Construction Corporation’s responsibility to notify DCR, and to conduct the appropriate IRA activities. DCR will contact the MassDEP on behalf of the Contractor.

EMERGENCY PROCEDURES AND SAFETY PRECAUTIONS

EMERGENCY RESPONSE FLOW CHART

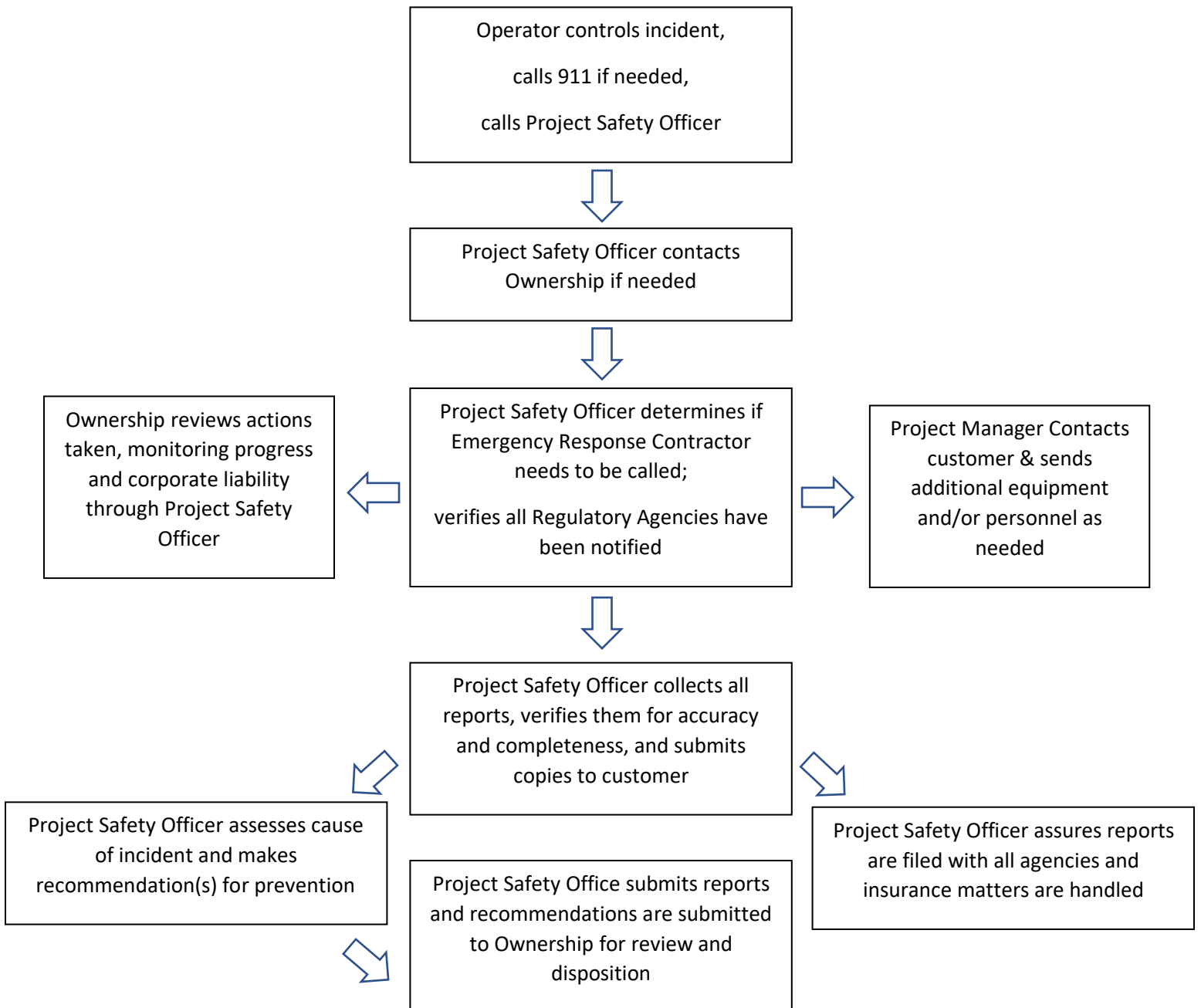

GENERAL SPILL PROVISIONS

In the event of a spill, surface terrain, direction and velocity of the prevailing wind, and proximity to possible ignition sources shall be observed by the Contractor or DCR Project Managers or their designees and roadblocks to be set up immediately, if necessary.

Trucks, hand tools, and equipment should not be moved into the spill area until precautions have been taken. When equipment is moved into the spill area it shall be removed as soon as its task is completed. Only personnel vital to the cleanup effort will be allowed in the spill area.

No ignitable materials (matches, lighter, smoking materials) will be allowed into the spill area.

Minor Spill (< 10 GALLONS)

All efforts will be made to contain the spill by erecting an earthen berm or barrier. The area will be remediated in accordance with all applicable state and federal regulations.

Large Spill (>10 GALLONS)

The spill will be contained to the smallest area possible using booms, berms, or other effective barriers. DCR and the Contractor Project Manager, Contractor project contact, and the MassDEP will be notified immediately.

The Project Safety Officer and/or onsite representatives will notify the following agencies depending on the nature of the response:

- Boston Conservation Commission
 - 617-635-3850 from 9:00 am to 5:00 pm Monday thru Friday
 - 617-635-4500 all other items
 - Nicholas Moreno via email at cc@boston.gov
- Emergency Response Contractor(s)
- Boston Police Department
- Boston Fire Department
- Local Hospital: Massachusetts General Hospital
55 Fruit Street
Boston, MA

EMERGENCY CONTACTS

EMERGENCY SERVICES Fire

Emergency	911
Medical Emergency Police	911
Emergency	911
Poison Control	(800) 542-4225
National Response Center	(800) 424-8802

DCR Contacts

DCR Project Manager/ DCR	Ginna Johnson	(857)324-1424
Deputy Chief Engineer DCR		
Deputy Commissioner of Operations	Nick Gove	(617) 875-1984
Environmental Director	Thomas Valton	(339) 368-2930
MassDEP	(Day)	(978) 694-3200
	(Night)	1-888-304-1133

INJURIES AND ILLNESSES

Immediate action steps:

1. Determine extent of injuries or illness;
2. Determine if immediate assistance is required at the scene, which has not already been initiated (e.g. ambulance, police, agency reporting etc.);
3. Do Not attempt any treatment unless trained to do so;
4. Be aware of the location of the First Aid Kit (use only if trained);
5. Take appropriate precautions to avoid exposure to blood/bodily fluids

6. Verbally report incident to Project Safety Officer
7. In the case of a serious injury or illness requiring hospitalization, arrangements to provide family transportation to the hospital/treating facility should be considered.
8. Provide periodic feedback and/or status reports on-line as often as required or necessary.

FUEL AND OIL SPILLS

If an oil or fuel release occurs, act quickly to ensure the following has been completed as appropriate.

Immediate action steps:

- De-activate equipment;
- Stop Work in area of Spill;
- Deploy a bucket to catch oil or fuel;
- Deploy sorbents to ground surface; and
- Bag spent sorbents.
- As appropriate, coordinate contractor pump-out and Emergency Response with Project Safety Officer
- Provide periodic feedback and/or status reports on-line as often as required.

FIRES

In a fire emergency, primary concern is for the safety of all employees, followed by protection of physical assets. The role of terminal/fleet employees is:

- Extinguish minor fires;
- Promptly notify the local Fire Department;
- Assist in the orderly and safe evacuation of the facility;
- Render assistance to the Fire Department, as required; and
- Notify appropriate management personnel.

If an employee observes or discovers a fire, or sees visible smoke, their first action is to alert employees, evacuate the building and notify the Fire Department.

Do not attempt to fight a fire if you are alone!

If an employee has been trained in the use of hand-portable fire extinguishers, attempt to extinguish the fire, or investigate the cause of smoke. In no event should the employee put themselves in jeopardy!

If an employee has not been trained in the use of fire extinguishers, remain at a safe distance and direct the responding response team or local Fire Department to the location of the fire or smoke.

If evacuation is required, all employees should immediately leave the building via the nearest

emergency exit and proceed away from the facility.

Verbally report incident to:

a) Ownership

- Operations Manager
- Project Safety Officer
- Provide periodic feedback and/or status reports as often as required.

WEATHER

During severe weather conditions, it is ultimately the Field Staff's decision whether or not it is safe to drive during icy and or snowy conditions.

- If the Field Staff makes a determination that it is unsafe to enter or drive into the Site, they must continue to the closest area available that they determine is safe to stop and call the Project Safety Officer.
- When inclement weather conditions are forecast that may ultimately result in unsafe conditions (ice, snow, hurricane, etc.) it is the responsibility of the Operations Manager to constantly stay updated with these conditions through local weather reports.
- The Operations Manager may ultimately make different decisions pertaining to different geographical areas that we service, it will ultimately be the Operations Manager and/or Ownership determining what areas will be serviced.

OTHER EMERGENCIES (SECURITY, BOMB THREAT, CIVIL DISTURBANCE, ETC.)

In an emergency as listed above, the primary concern is for the safety of all employees, followed by protection of physical assets. The role of the employees is to:

- Secure the premises immediately;
- Promptly notify the local Fire and/or Police Departments;
- Assist in the orderly and safe evacuation of the facility/premises;
- Render assistance to the Civil Departments responding; and
- Notify appropriate management personnel.

In no event should the employee put himself or herself in jeopardy!

In an emergency as listed above, the primary concern is for the safety of all employees, subcontractors and protection of physical assets. The role of the employee is:

- Avoid situations that have a potential to become an emergency;
- Contact dispatch using your cell-phone providing them with your location and description of your emergency;
- Contact the local authorities; and
- Once you have located a safe haven, call the Operations Manager, Ownership and/or Project Safety Officer.

EMPLOYEE RESPONSIBILITIES

In the event of an emergency, immediately (or as soon as practical and necessary) notify management who will assist employees handling the incident. Management will be responsible for directing corrective actions, coordinating clean-up operations and/or monitoring the use of emergency equipment by outside services, as required.

Additional Responsibilities:

- a) Assure that local police, fire, ambulance, National Response Center, EPA and Coast Guard, if dictated by the emergency, have been notified of the following:
 - Exact location of the incident
 - Nature and extent of injuries, if any
 - Specific products on board
 - Apparent condition of the vehicle
 - Need to apply foam (if volatile products have been released)
 - Any other real or potential hazards that are known at that time

- b) Contact the Project Safety Officer for emergency information/assistance regarding Federal/State reporting requirements, environmental remediation and/or employee safety and health issues.

TRAINING

Training on the Emergency Response Plan, including a review of potential emergency situations, individual roles/responsibilities, reporting requirements and appropriate sections of this Plan should be conducted for all employees immediately upon assignment. Refresher training will be required on an annual basis, or whenever changes or updates to the Plan are made.

EMERGENCY TELEPHONE NUMBERS

- Steve Cyr, 617-304-6164
- Nick Gove, 617-875-1984
- Ale Echandi, Ecologist, 617-850-2398

ATTACHMENT A–ACCIDENT, SPILL & CONTAINMENT REPORTING FORM

Purpose

To provide managers and field staff with a procedure to properly report an accident, spill/contamination and safety incident and eliminate the need for personal decisions regarding the reporting procedures. This procedure helps ensure uniformity throughout the organization regarding accurate, timely and complete safety incident reporting. The procedure is written to maximize safety response and minimize injury.

Scope

The safety incident report must be completed each time an/accident, spill/contamination or work injury occurs within the organization. This includes the reporting requirements from initial notification to the completion of the report.

Responsibility

The field staff is responsible to call the Project Safety Officer's 24-hour cell phone number immediately to accurately report information regarding all aspects of the safety incident. The field staff must also complete the written incident report form and other documents, as necessary, provided in the accident report kit.

The Project Safety Officer will assist and administrate the field staff to handle the safety incident and in preparation of the written accident report. The Project Safety Officer will also complete the Contamination/Spill Report and Manager's Report of Injury to Employee when necessary.

Procedure

Every safety incident must be reported immediately to the Project Safety Officer by calling the **24/7** emergency number. An emergency phone list is provided in the Emergency Response Procedure section of this manual in case the emergency number is out of service. Contractor contact information will be provided following the hiring of said contractor. Field Staff must call unless injury or safety precautions prevent him from doing so.

- An accident is defined as any unplanned event that may result in injury or interrupt the completion of an activity, and which may (or may not) include property damage.
- A spill is defined as a release of fluids from tanks, containers or vessels accidentally or unintentionally.
- Contamination is defined as any substance or reaction that causes the original product to be altered from its original state or purity.

The field staff involved in the safety incident is responsible for documenting pertinent facts and information relating to the cause and disposition of the incident. The field staff must properly complete the accident report kit provided. This includes:

- Taking photographs of the accident site, specific damage and for evidence of cause. Use your best judgment and when in doubt, take the photograph.
- Two witness cards are provided to be completed by up to two individuals who witness the

incident. One courtesy card is included for use if the field staff cannot leave the accident site. The card may be given to an individual on site to call and report the safety incident.

- A note card is included to write down any facts or statements that provide evidence pertinent to the safety incident.
- The completed documentation in the accident report kit must be turned into the office before completion of scheduled shift. If not able to do so other arrangements will be made. In the event of injury to the field staff, the Project Safety Officer is responsible to see that the accident report is completed to the best of his/her ability. This may include going to the site or authorizing company personnel on site to obtain necessary disposition.
- The Project Safety Officer will administer the reporting and claims processes and maintain required files.

Emergency Response Procedures

In the event of an accident, equipment breakdown, malfunction or human error, which results in the release of any oil, fuel, hazardous or non-hazardous product, the field staff should attempt to implement the following procedures.

APPROACH THE SCENE CAUTIOUSLY

Do not rush in to assist, or you may be added to the list of casualties. Prevent others from doing the same. DO NOT attempt any action beyond your level of training. DO call for help.

Identify The Hazards

Consult placards, container labels, MSDS, shipping papers, Emergency Response Guidebook and/or knowledgeable persons at the scene. Evaluate all available information before concluding on a course of action. Do not assume the material is harmless because it lacks a color or odor. If limited information is available, err on the side of caution; as more specific information becomes available, the response can be tailored to the hazard.

Secure The Area

Establish an exclusion zone that will keep non-emergency personnel well out of danger. It may be necessary to patrol the area to keep spectators at a safe distance.

Obtain Help

Contact the appropriate local emergency services and your Project Safety Officer as soon as possible. Be prepared to provide as much of the following information as possible:

- Location of release - a physical site address, town/city and state/providence, mile marker along a highway, direction of travel, or any other information, which will direct a responding emergency response cleanup crew.
- Details of release - what was released, what time it occurred, cause of the release, how much has been released, measures taken to prevent the release, and what media or mediums have been impacted by the release (i.e., storm drains, streams, roads, or soils.)

Communications - provide the following if available: names and phone numbers of authorities contacted or at the scene, contact person and phone number if at a client's facility, and ensure that the MSDS is available to responding authorities. In a hazardous material incident, the transmittal of TIMELY and ACCURATE information is essential. This is especially true when determining the identity of the material(s) involved.

Emergency Response Priorities

- Prevent or reduce the loss of lives or injury to responders and the public. Prevent or reduce the loss of property or damage to property. Prevent or reduce the effects of the release upon the environment. Restore the area to normal (operational) conditions.

Emergency Spill Response Telephone Notification Procedure

- Field Staff reports the incident to the Project Safety Officer and to the local police and fire departments by dialing 911.
- The Project Safety Officer will coordinate with an emergency responder when required.

Depending on the nature of the release; the Project Safety Officer will report the incident to all appropriate authorities including the PHMSA's National Response Center and will need the following information:

1. Name, address and telephone number of the company and call back number
2. Location of spill (physical address, country and state)
3. Time and duration of release
4. Cause of release
5. Chemical identity of material released/ DOT identification number
6. Estimated amount of release (gallons, pounds)
7. Medium or media into which the release occurred
8. Hazard classification of released material
9. Containment efforts
10. Distance to nearest water body or storm drain
11. Name of cleanup contractor called and estimated time of arrival
12. Shipper and consignee information
13. Manufacturer, if known
14. Bill of lading number/waybill number

DCR - SPILL OR INCIDENT REPORT FORM

Instructions: Complete for any type of petroleum product or hazardous materials/waste spill or incident. Provide a copy of this report to management.

1. DCR Personnel Involved in Spill Reporting:

Project Supervisor: Name, Title, and Phone Number: _____

DCR Project Safety Officer: Name, Title, and Phone Number: _____

2. Contractor

Name and Title of Person Responsible for Spill Response: _____

Phone Number: _____

3. General Spill Information:

Common Name of Spilled Substance: _____

Quantity Spilled (Estimate): _____

Describe Concentration of Material (Estimate): _____

Date of Spill: ____ / ____ / ____

Time Spill Started: ____ AM ____ PM

Time Spill Ended: ____ AM ____ PM

4. Spill Location and Conditions:

Project Title: _____

Street Address and City /or District & Park Name: _____

Weather Conditions: _____

If Spill to Water,

Name of Water Body (if ditch or culvert, identify the water body that the structure discharges to):

Identify the Discharge Point: _____

Estimate the Depth and Width of the Water Body: _____

Estimate Flow Rate (i.e. slow, moderate, or fast): _____

Describe Environmental Damage (i.e., fish kill?): _____

5. Actions taken:

To Contain Spill or Impact of Incident: _____

To Cleanup Spill or Recover from Incident: _____

To Remove Cleanup Material: _____

To Document Disposal: _____

To Prevent Reoccurrence: _____

6. Reporting the Spill:

Spills to water & soil that may be an immediate threat to health or the environment (i.e., explosive, flammable, toxic vapors, shallow groundwater, nearby creek, etc.):

Immediately call DCR Environmental Director Thomas Valton - cell# 339.368.2930

Note: Project specific permits may have additional reporting requirements.

List all agencies contacted; include names, dates, and phone numbers for people you spoke with:

7. Person Responsible for Managing Termination/Closure of Incident or Spill:

Name and Phone: _____

Address and Fax: _____

8. Additional Notes/Information (if necessary):

APPENDIX G

Spill Prevention Plan

OIL SPILL PREVENTION, CONTROL

AND

COUNTERMEASURE PLAN

FOR

**VEGITATION MANAGEMENT ALONG CHARLES RIVER
CHARLES RIVER RESERVATION, BOSTON MA**

PREPARED: AUGUST 28, 2021



Contents

INTRODUCTION.....	1
DESCRIPTION OF PROJECT	1
PLAN MAINTENANCE AND DISTRIBUTION	1
MOTOR VEHICLE ACCIDENTS.....	2
OIL AND HAZARDOUS INCIDENT REPORTING.....	2
NOTIFICATION OF RELEASES.....	4
RELEASES THAT REQUIRE NOTIFICATION TO MASSDEP	4
EMERGENCY PROCEDURES AND SAFETY PRECAUTIONS.....	5
EMERGENCY RESPONE FLOW CHART	5
GENERAL SPILL PROVISIONS	6
Minor Spill (< 10 GALLONS)	6
Large Spill (>10 GALLONS)	6
EMERGENCY CONTACTS	6
INJURIES AND ILLNESSES	7
FUEL AND OIL SPILLS.....	7
FIRES.....	7
WEATHER	8
OTHER EMERGENCIES (SECURITY, BOMB THREAT, CIVIL DISTURBANCE, ETC.).....	8
EMPLOYEE RESPONSIBILITIES	8
TRAINING	9
EMERGENCY TELEPHONE NUMBERS.....	9
ATTACHMENT A–ACCIDENT, SPILL & CONTAINMENT REPORTING FORM.....	10
Purpose	10
Scope.....	10
Responsibility.....	10
Procedure.....	10
Emergency Response Procedures.....	11

INTRODUCTION

This Oil Spill Prevention, Control and Countermeasure Plan (OSPCCP) has been developed by the Massachusetts Department of Conservation & Recreation (DCR) as a required supplement for DCR's Vegetation Management project along the Charles River to be conducted in Boston, Massachusetts (Project Site).

Approximate location:

Latitude: 42.3643 N

Longitude: 71.1378 W

The purpose of the Oil Spill Prevention, Control and Countermeasure Plan is to prepare DCR and their contractor and its employees for emergency situations which may occur. Typical emergencies for which we need to be prepared include spills and leaks, personal injuries, fires, weather-related emergencies and other situations which require operational response.

The content of this Oil Spill Prevention, Control and Countermeasure Plan includes:

- Descriptions of expected emergencies, their hazards, and the recommended plan of action to combat their effects.
- Procedures for reporting employee injuries, motor vehicle accidents, spills, product contamination or any other emergencies which may occur.
- Emergency contact phone numbers
- Decision making infrastructure with defined action steps that can be executed quickly.

DESCRIPTION OF PROJECT

In anticipation of the Head of the Charles, DCR is proposing to manage (trim) vegetation along the riparian buffer to provide views of the water for event spectators, organizers and emergency personnel (Project). As part of the Project, nuisance shrubs such as false indigo, and invasive shrubs and perennials growing along the riparian buffer will be trimmed to a minimum height of 18-inches from the Reservation's finished grade at an approximate width of 6-feet. Care will be used to minimize the possibility of trimmed vegetation falling into the River. Any vegetation that enters the River will be removed if it is safe to do so. Trimmed vegetation will be raked and stockpiled on the finished grade for removal and disposal upon completion of the activities and prior to the Head of the Charles

PLAN MAINTENANCE AND DISTRIBUTION

Copies of the Oil Spill Prevention, Control and Countermeasure Plan will be distributed as follows:

- DCR Project Manager
- Contractor Project Manager
- Contractor Field Managers

Designated recipients of the Oil Spill Prevention, Control and Countermeasure Plan will be offered training in the plan.

Requests for changes to Oil Spill Prevention, Control and Countermeasure Plan should be submitted in writing to the Project Safety Officer.

If there are any questions concerning changes to the plan, or if other revisions are required, contact the Project Safety Officer.

MOTOR VEHICLE ACCIDENTS

Immediate action steps:

1. Determine extent of the accident and any injuries.
2. If spill response assistance is required due to the size of the spill, location, or inability to immediately control it, or there is potential for the spill to impact the environment, immediately notify the Project Safety Officer who will then make the determination to contact our Insurance and/or Environmental Response Vendor.
3. Determine if immediate assistance is required at the accident scene that has not already been initiated (e.g. ambulance, police, tow truck, agency reporting, other vehicle to transfer cargo, etc.).
4. Verbally report accident to the Project Safety Officer.
5. Provide periodic feedback and/or status reports as often as required or necessary.
6. Should a motor vehicle accident result in personal injury, fatality, or any vehicle being towed or a product release to the ground, sewer, or navigable waterway, the Project Safety Officer will make an immediate verbal report to ownership.

OIL AND HAZARDOUS INCIDENT REPORTING

A "Hazardous Material Reportable Incident" is an occurrence during the course of transporting a hazardous material by truck, rail or air (including during loading, unloading and temporary storage) in which, as a direct result of the hazardous material:

- A person is killed;
- A person receives injuries requiring hospitalization;
- Estimated carrier or other property damage exceeds \$50,000 (excluding vehicle/property damage unless caused by the material/product itself);
- An evacuation of the general public occurs lasting one or more hours;
- One or more major transportation arteries or facilities are closed or shut down for one hour or more; or
- The operation, flight pattern or routine of an aircraft is altered.

Or

- A situation exists of such a nature (i.e., a continuing danger to life at the scene) that, in the judgment of the Project Safety Officer, should be reported even though it does not meet the criteria above.

Or

- An unintentional release of a hazardous material from a container (i.e., tank truck) caused by failure of the container or operator.

Incidents meeting the above definition(s) must be reported to the Project Safety Officer. If the incident meets any of the criteria in the first two paragraphs above, reporting must be immediate by telephone to the National Response Center (800-424-8802). The Project Safety Officer will make the report which will include the following information:

- Name of reporter;
- Name and address of the carrier represented by the reporter;
- Phone number where the reporter can be contacted;
- Date, time and location of the incident;
- Extent of injuries if any;
- Classification, name and quantity of hazardous material involved; and
- Type of incident and whether a continuing danger to life exists at the scene.

In the case of property damage greater than \$50,000, it may take some time to obtain estimates that are reliable and accurate enough to determine the total cost. If that's the only trigger for "immediate" reporting; telephonic notification, even days later, is acceptable. A telephone report must be followed within 30 days by a written report.

If the incident meets only the third item above, the report does not need to be immediate, but must be submitted in writing within 30 days of the incident.

Local Procedures: Field Staff must notify the Project Safety Officer for the following examples but not limited to these examples. Product spills, all motor vehicle accidents involving injuries significant property damage over one thousand dollars or if either vehicle is towed or if any party is taken to the hospital or if you are issued a citation, and any personal injury. **All spills regardless of quantity, must be reported immediately to the Project Safety Officer.**

Licensed Site Professional (LSP): A LSP has responsibility for issues associated with Oil and Hazardous Materials Releases that occur pursuant to Massachusetts Department of Environmental Protections (MassDEP) Massachusetts Contingency Plan (MCP) at 310 CMR 40.0000. The LSP is a hazardous waste consultant, as defined in M.G.L. C 21A paragraph 19 and holds a valid license issued by the Board of the Registration of Hazardous Waste Site Cleanup Professionals pursuant to M.G.L. C21A, paragraph 19-19J. In the event of a release of hazardous materials to soil or water, a LSP will be employed to provide necessary reporting to DEP or other appropriate regulatory agencies, and to coordinate any necessary site remediation activities.

The Licensed Site Professional (LSP) is required to provide the services necessary to comply with the requirements of the MCP. These services may include sampling, analysis and characterization of potentially contaminated media, preparation of Immediate Response Action (IRA) Plans, Utility-Related Abatement Measure (URAM) and Release Abatement Measure (RAM) Plans, Imminent Hazard Evaluations, status reports, transmittal forms, release notification forms, risk assessments, completion statements, and related documents required pursuant to the Massachusetts Contingency Plan (MCP).

The LSP shall evaluate soil and/or sediment with discoloration, odor, and presence of petroleum liquid or sheening on the groundwater surface, or any abnormal gas or materials in the ground which are known or suspected to be oil or hazardous materials.

NOTIFICATION OF RELEASES

The LSP is responsible for generating and submitting all soil tracking logs, daily field reports, analytical results, and MCP related reports (i.e. IRAs, URAMs, RAMs). These reports or logs will contain all field observations relevant to MCP issues, all data generated, and justification for all actions taken. The Contractor's LSP will be available to meet with DCR or its agents to discuss, clarify, or justify actions taken and data generated, and to accommodate comments or requests made by DCR or its agents.

RELEASES THAT REQUIRE NOTIFICATION TO MASSDEP

This section discusses release(s) that require notification to the MassDEP, as specified in 310 CMR 40.0310. If a 120-day reportable condition is encountered during characterization of soil that has not previously reported under RTN 3-1283. All work related to this "new" condition would be completed in accordance with requirements of the MCP. The Site is currently closed under the MCP and as such, reporting of a new release will only be required if a 2 or 72-hour condition is identified; or a contaminant not previously identified as a contaminant of concern is detected above reportable concentrations.

120-day notification conditions include, but are not limited to, the following:

- OHM detected in soil and/or groundwater at concentrations exceeding the applicable Reportable Concentrations
- The presence of Non-Aqueous Phase Liquid (NAPL) having a measured thickness equal to or greater than 1/8 inch and less than 1/2 inch.

A RAM, URAM, or other feasible MCP option, cannot be initiated or continued in the area where a two (2)-hour or seventy-two (72)-hour release or threat of release has been identified, as described in 310 CMR 40.0311 through 40.0314, until an Immediate Response Action (IRA) has been undertaken and an IRA Completion Statement has been submitted to the MassDEP. Remedial activities that are scheduled to take place in areas bordering other remedial area boundaries will be structured and monitored to assure they do not impact the conditions of other Remedial Activities.

Two (2)-hour notification conditions include, but are not limited to, the following:

- A release, or threat of release, of OHM over a 24-hour period that is equal to, greater than, or likely to be greater than, the MCP Reportable Quantity of that material
- Sudden release to water producing a sheen
- Release to a storm drain, or sanitary sewer posing an Imminent Hazard (as defined in 310 CMR 40.000)
- OHM detected in a private drinking water well at a concentration greater than or equal to the applicable MCP GW-1 RC.

Seventy-two (72)-hour notification conditions include, but are not limited to, the following:

- Identification of non-aqueous phase liquid (NAPL) on groundwater or surface water, with a thickness equal to or greater than 1/2 inches.
- OHM detected in the Zone I of a public water supply or within 500-feet of a private drinking water well at concentrations greater than or equal to the applicable MCP GW-1 Reportable Concentration
- Release or threat of release from an underground storage tank.

If these, or other conditions requiring two (2) or seventy-two (72)-hour notification, are found on-site it is Newport Construction Corporation’s responsibility to notify DCR, and to conduct the appropriate IRA activities. DCR will contact the MassDEP on behalf of the Contractor.

EMERGENCY PROCEDURES AND SAFETY PRECAUTIONS

EMERGENCY RESPONSE FLOW CHART

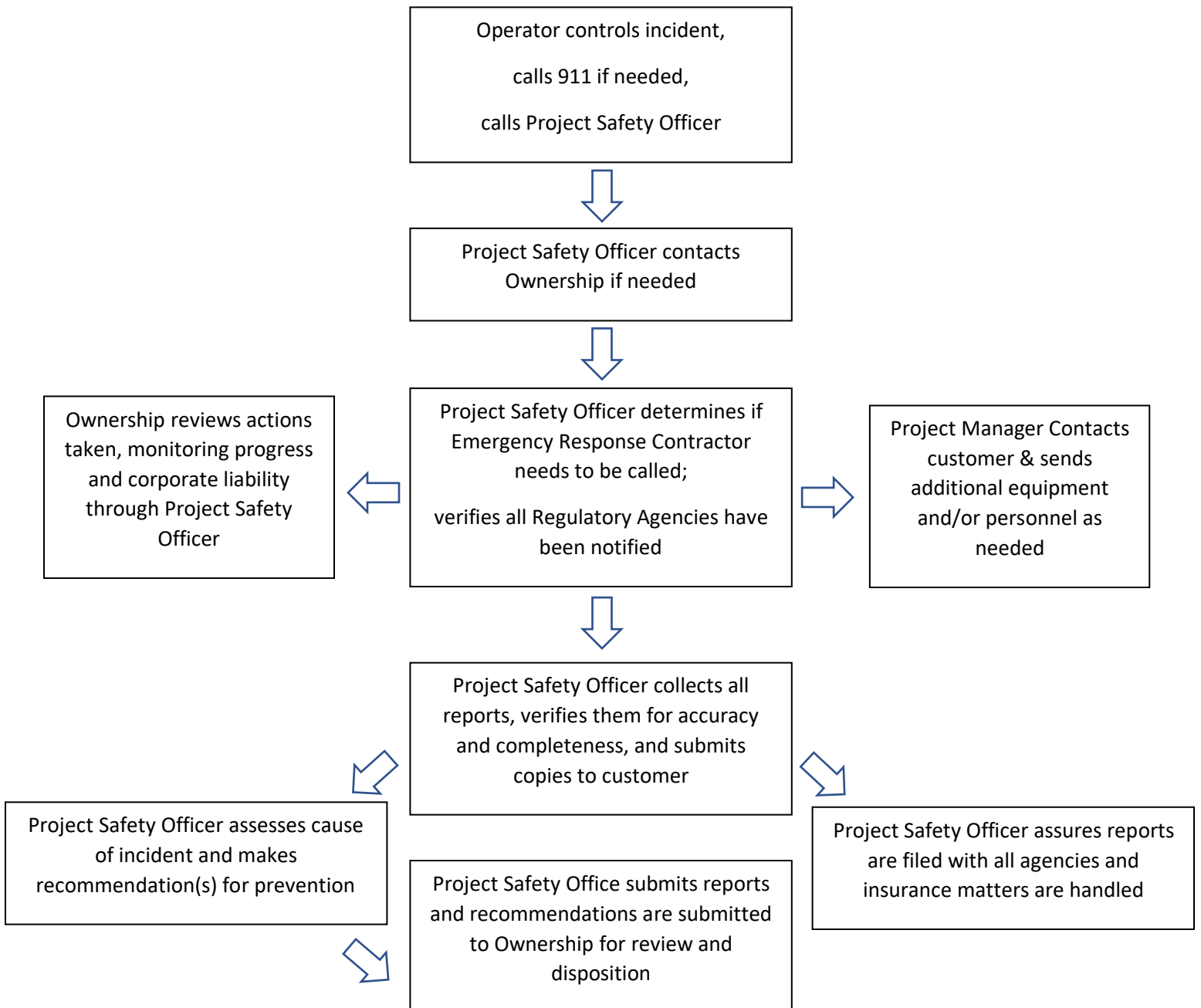

GENERAL SPILL PROVISIONS

In the event of a spill, surface terrain, direction and velocity of the prevailing wind, and proximity to possible ignition sources shall be observed by the Contractor or DCR Project Managers or their designees and roadblocks to be set up immediately, if necessary.

Trucks, hand tools, and equipment should not be moved into the spill area until precautions have been taken. When equipment is moved into the spill area it shall be removed as soon as its task is completed. Only personnel vital to the cleanup effort will be allowed in the spill area.

No ignitable materials (matches, lighter, smoking materials) will be allowed into the spill area.

Minor Spill (< 10 GALLONS)

All efforts will be made to contain the spill by erecting an earthen berm or barrier. The area will be remediated in accordance with all applicable state and federal regulations.

Large Spill (>10 GALLONS)

The spill will be contained to the smallest area possible using booms, berms, or other effective barriers. DCR and the Contractor Project Manager, Contractor project contact, and the MassDEP will be notified immediately.

The Project Safety Officer and/or onsite representatives will notify the following agencies depending on the nature of the response:

- Boston Conservation Commission
 - 617-635-3850 from 9:00 am to 5:00 pm Monday thru Friday
 - 617-635-4500 all other items
 - Nicholas Moreno via email at cc@boston.gov
- Emergency Response Contractor(s)
- Boston Police Department
- Boston Fire Department
- Local Hospital: Massachusetts General Hospital
55 Fruit Street
Boston, MA

EMERGENCY CONTACTS

EMERGENCY SERVICES Fire

Emergency	911
Medical Emergency Police	911
Emergency	911
Poison Control	(800) 542-4225
National Response Center	(800) 424-8802

DCR Contacts

DCR Project Manager/ DCR	Ginna Johnson	(857)324-1424
Deputy Chief Engineer DCR		
Deputy Commissioner of Operations	Nick Gove	(617) 875-1984
Environmental Director	Thomas Valton	(339) 368-2930
MassDEP	(Day)	(978) 694-3200
	(Night)	1-888-304-1133

INJURIES AND ILLNESSES

Immediate action steps:

1. Determine extent of injuries or illness;
2. Determine if immediate assistance is required at the scene, which has not already been initiated (e.g. ambulance, police, agency reporting etc.);
3. Do Not attempt any treatment unless trained to do so;
4. Be aware of the location of the First Aid Kit (use only if trained);
5. Take appropriate precautions to avoid exposure to blood/bodily fluids

6. Verbally report incident to Project Safety Officer
7. In the case of a serious injury or illness requiring hospitalization, arrangements to provide family transportation to the hospital/treating facility should be considered.
8. Provide periodic feedback and/or status reports on-line as often as required or necessary.

FUEL AND OIL SPILLS

If an oil or fuel release occurs, act quickly to ensure the following has been completed as appropriate.

Immediate action steps:

- De-activate equipment;
- Stop Work in area of Spill;
- Deploy a bucket to catch oil or fuel;
- Deploy sorbents to ground surface; and
- Bag spent sorbents.
- As appropriate, coordinate contractor pump-out and Emergency Response with Project Safety Officer
- Provide periodic feedback and/or status reports on-line as often as required.

FIRES

In a fire emergency, primary concern is for the safety of all employees, followed by protection of physical assets. The role of terminal/fleet employees is:

- Extinguish minor fires;
- Promptly notify the local Fire Department;
- Assist in the orderly and safe evacuation of the facility;
- Render assistance to the Fire Department, as required; and
- Notify appropriate management personnel.

If an employee observes or discovers a fire, or sees visible smoke, their first action is to alert employees, evacuate the building and notify the Fire Department.

Do not attempt to fight a fire if you are alone!

If an employee has been trained in the use of hand-portable fire extinguishers, attempt to extinguish the fire, or investigate the cause of smoke. In no event should the employee put themselves in jeopardy!

If an employee has not been trained in the use of fire extinguishers, remain at a safe distance and direct the responding response team or local Fire Department to the location of the fire or smoke.

If evacuation is required, all employees should immediately leave the building via the nearest

emergency exit and proceed away from the facility.

Verbally report incident to:

a) Ownership

- Operations Manager
- Project Safety Officer
- Provide periodic feedback and/or status reports as often as required.

WEATHER

During severe weather conditions, it is ultimately the Field Staff's decision whether or not it is safe to drive during icy and or snowy conditions.

- If the Field Staff makes a determination that it is unsafe to enter or drive into the Site, they must continue to the closest area available that they determine is safe to stop and call the Project Safety Officer.
- When inclement weather conditions are forecast that may ultimately result in unsafe conditions (ice, snow, hurricane, etc.) it is the responsibility of the Operations Manager to constantly stay updated with these conditions through local weather reports.
- The Operations Manager may ultimately make different decisions pertaining to different geographical areas that we service, it will ultimately be the Operations Manager and/or Ownership determining what areas will be serviced.

OTHER EMERGENCIES (SECURITY, BOMB THREAT, CIVIL DISTURBANCE, ETC.)

In an emergency as listed above, the primary concern is for the safety of all employees, followed by protection of physical assets. The role of the employees is to:

- Secure the premises immediately;
- Promptly notify the local Fire and/or Police Departments;
- Assist in the orderly and safe evacuation of the facility/premises;
- Render assistance to the Civil Departments responding; and
- Notify appropriate management personnel.

In no event should the employee put himself or herself in jeopardy!

In an emergency as listed above, the primary concern is for the safety of all employees, subcontractors and protection of physical assets. The role of the employee is:

- Avoid situations that have a potential to become an emergency;
- Contact dispatch using your cell-phone providing them with your location and description of your emergency;
- Contact the local authorities; and
- Once you have located a safe haven, call the Operations Manager, Ownership and/or Project Safety Officer.

EMPLOYEE RESPONSIBILITIES

In the event of an emergency, immediately (or as soon as practical and necessary) notify management who will assist employees handling the incident. Management will be responsible for directing corrective actions, coordinating clean-up operations and/or monitoring the use of emergency equipment by outside services, as required.

Additional Responsibilities:

- a) Assure that local police, fire, ambulance, National Response Center, EPA and Coast Guard, if dictated by the emergency, have been notified of the following:
 - Exact location of the incident
 - Nature and extent of injuries, if any
 - Specific products on board
 - Apparent condition of the vehicle
 - Need to apply foam (if volatile products have been released)
 - Any other real or potential hazards that are known at that time

- b) Contact the Project Safety Officer for emergency information/assistance regarding Federal/State reporting requirements, environmental remediation and/or employee safety and health issues.

TRAINING

Training on the Emergency Response Plan, including a review of potential emergency situations, individual roles/responsibilities, reporting requirements and appropriate sections of this Plan should be conducted for all employees immediately upon assignment. Refresher training will be required on an annual basis, or whenever changes or updates to the Plan are made.

EMERGENCY TELEPHONE NUMBERS

- Steve Cyr, 617-304-6164
- Nick Gove, 617-875-1984
- Ale Echandi, Ecologist, 617-850-2398

ATTACHMENT A–ACCIDENT, SPILL & CONTAINMENT REPORTING FORM

Purpose

To provide managers and field staff with a procedure to properly report an accident, spill/contamination and safety incident and eliminate the need for personal decisions regarding the reporting procedures. This procedure helps ensure uniformity throughout the organization regarding accurate, timely and complete safety incident reporting. The procedure is written to maximize safety response and minimize injury.

Scope

The safety incident report must be completed each time an/accident, spill/contamination or work injury occurs within the organization. This includes the reporting requirements from initial notification to the completion of the report.

Responsibility

The field staff is responsible to call the Project Safety Officer's 24-hour cell phone number immediately to accurately report information regarding all aspects of the safety incident. The field staff must also complete the written incident report form and other documents, as necessary, provided in the accident report kit.

The Project Safety Officer will assist and administrate the field staff to handle the safety incident and in preparation of the written accident report. The Project Safety Officer will also complete the Contamination/Spill Report and Manager's Report of Injury to Employee when necessary.

Procedure

Every safety incident must be reported immediately to the Project Safety Officer by calling the **24/7** emergency number. An emergency phone list is provided in the Emergency Response Procedure section of this manual in case the emergency number is out of service. Contractor contact information will be provided following the hiring of said contractor. Field Staff must call unless injury or safety precautions prevent him from doing so.

- An accident is defined as any unplanned event that may result in injury or interrupt the completion of an activity, and which may (or may not) include property damage.
- A spill is defined as a release of fluids from tanks, containers or vessels accidentally or unintentionally.
- Contamination is defined as any substance or reaction that causes the original product to be altered from its original state or purity.

The field staff involved in the safety incident is responsible for documenting pertinent facts and information relating to the cause and disposition of the incident. The field staff must properly complete the accident report kit provided. This includes:

- Taking photographs of the accident site, specific damage and for evidence of cause. Use your best judgment and when in doubt, take the photograph.
- Two witness cards are provided to be completed by up to two individuals who witness the

incident. One courtesy card is included for use if the field staff cannot leave the accident site. The card may be given to an individual on site to call and report the safety incident.

- A note card is included to write down any facts or statements that provide evidence pertinent to the safety incident.
- The completed documentation in the accident report kit must be turned into the office before completion of scheduled shift. If not able to do so other arrangements will be made. In the event of injury to the field staff, the Project Safety Officer is responsible to see that the accident report is completed to the best of his/her ability. This may include going to the site or authorizing company personnel on site to obtain necessary disposition.
- The Project Safety Officer will administer the reporting and claims processes and maintain required files.

Emergency Response Procedures

In the event of an accident, equipment breakdown, malfunction or human error, which results in the release of any oil, fuel, hazardous or non-hazardous product, the field staff should attempt to implement the following procedures.

APPROACH THE SCENE CAUTIOUSLY

Do not rush in to assist, or you may be added to the list of casualties. Prevent others from doing the same. DO NOT attempt any action beyond your level of training. DO call for help.

Identify The Hazards

Consult placards, container labels, MSDS, shipping papers, Emergency Response Guidebook and/or knowledgeable persons at the scene. Evaluate all available information before concluding on a course of action. Do not assume the material is harmless because it lacks a color or odor. If limited information is available, err on the side of caution; as more specific information becomes available, the response can be tailored to the hazard.

Secure The Area

Establish an exclusion zone that will keep non-emergency personnel well out of danger. It may be necessary to patrol the area to keep spectators at a safe distance.

Obtain Help

Contact the appropriate local emergency services and your Project Safety Officer as soon as possible. Be prepared to provide as much of the following information as possible:

- Location of release - a physical site address, town/city and state/providence, mile marker along a highway, direction of travel, or any other information, which will direct a responding emergency response cleanup crew.
- Details of release - what was released, what time it occurred, cause of the release, how much has been released, measures taken to prevent the release, and what media or mediums have been impacted by the release (i.e., storm drains, streams, roads, or soils.)

Communications - provide the following if available: names and phone numbers of authorities contacted or at the scene, contact person and phone number if at a client's facility, and ensure that the MSDS is available to responding authorities. In a hazardous material incident, the transmittal of TIMELY and ACCURATE information is essential. This is especially true when determining the identity of the material(s) involved.

Emergency Response Priorities

- Prevent or reduce the loss of lives or injury to responders and the public. Prevent or reduce the loss of property or damage to property. Prevent or reduce the effects of the release upon the environment. Restore the area to normal (operational) conditions.

Emergency Spill Response Telephone Notification Procedure

- Field Staff reports the incident to the Project Safety Officer and to the local police and fire departments by dialing 911.
- The Project Safety Officer will coordinate with an emergency responder when required.

Depending on the nature of the release; the Project Safety Officer will report the incident to all appropriate authorities including the PHMSA's National Response Center and will need the following information:

1. Name, address and telephone number of the company and call back number
2. Location of spill (physical address, country and state)
3. Time and duration of release
4. Cause of release
5. Chemical identity of material released/ DOT identification number
6. Estimated amount of release (gallons, pounds)
7. Medium or media into which the release occurred
8. Hazard classification of released material
9. Containment efforts
10. Distance to nearest water body or storm drain
11. Name of cleanup contractor called and estimated time of arrival
12. Shipper and consignee information
13. Manufacturer, if known
14. Bill of lading number/waybill number

DCR - SPILL OR INCIDENT REPORT FORM

Instructions: Complete for any type of petroleum product or hazardous materials/waste spill or incident. Provide a copy of this report to management.

1. DCR Personnel Involved in Spill Reporting:

Project Supervisor: Name, Title, and Phone Number: _____

DCR Project Safety Officer: Name, Title, and Phone Number: _____

2. Contractor

Name and Title of Person Responsible for Spill Response: _____

Phone Number: _____

3. General Spill Information:

Common Name of Spilled Substance: _____

Quantity Spilled (Estimate): _____

Describe Concentration of Material (Estimate): _____

Date of Spill: ____/____/____

Time Spill Started: ____ AM ____ PM

Time Spill Ended: ____ AM ____ PM

4. Spill Location and Conditions:

Project Title: _____

Street Address and City /or District & Park Name: _____

Weather Conditions: _____

If Spill to Water,

Name of Water Body (if ditch or culvert, identify the water body that the structure discharges to):

Identify the Discharge Point: _____

Estimate the Depth and Width of the Water Body: _____

Estimate Flow Rate (i.e. slow, moderate, or fast): _____

Describe Environmental Damage (i.e., fish kill?): _____

5. Actions taken:

To Contain Spill or Impact of Incident: _____

To Cleanup Spill or Recover from Incident: _____

To Remove Cleanup Material: _____

To Document Disposal: _____

To Prevent Reoccurrence: _____

6. Reporting the Spill:

Spills to water & soil that may be an immediate threat to health or the environment (i.e., explosive, flammable, toxic vapors, shallow groundwater, nearby creek, etc.):

Immediately call DCR Environmental Director Thomas Valton - cell# 339.368.2930

Note: Project specific permits may have additional reporting requirements.

List all agencies contacted; include names, dates, and phone numbers for people you spoke with:

7. Person Responsible for Managing Termination/Closure of Incident or Spill:

Name and Phone: _____

Address and Fax: _____

8. Additional Notes/Information (if necessary):



**AFFIDAVIT OF SERVICE
FOR ABUTTER NOTIFICATION**

**Under the Massachusetts Wetlands Protection Act
and Boston Wetlands Ordinance**

I, Becky Barber, hereby certify under pains and penalties of perjury that that at least one week prior to the public hearing, I gave notice to abutters in compliance with the second paragraph of Massachusetts General Laws Chapter 131, section 40, and the DEP Guide to Abutter Notification dated April 8, 1994, in connection with the following matter:

A Notice of Intent was filed under the Massachusetts Wetlands Protection Act and/or the Boston Wetlands Ordinance by DCR for Charles River Vegetation Management Plan located at Charles River Reservation

The Abutter Notification For, the list of abutters to whom it was given, and their addresses are attached to this Affidavit of Service.

Becky Barber
Name

4/27/2022
Date

Environmental Monitor Preview

Publish Date:04/25/2022

Environmental Notification Forms

EEA No.	Project Name	Municipality	Document Type	Comments Due	For Copies	MEPA Analyst
16547	Alexan Chelmsford	CHELMSFORD	ENF	05/16/2022	Timothy Williams (781) 935-6889 TWilliams@Allenmajor.com	Purvi Patel, (617)874-0668, purvi.patel@mass.gov
16548	40 Roland Street	BOSTON	ENF	05/31/2022	Stephanie Krueel (617) 607-2972 skrueel@vhb.com	Purvi Patel, (617)874-0668, purvi.patel@mass.gov
16549	Big Y Supermarket	UXBRIDGE	EENF	05/25/2022	Luke DiStefano (508) 480-9900 ldistefano@bohlereeng.com	Purvi Patel, (617)874-0668, purvi.patel@mass.gov

Projects Submitted - Site Visits

EEA No.	Project Name	Municipality	Meeting Date	Meeting Time	Location
13940	ADM Tihonet Mixed Use Development	CARVER, PLYMOUTH, WAREHAM	05/12/2022	6:30 pm	REMOTE MEETING. Please RSVP to alexander.strysky@mass.gov at least one hour before the meeting for instructions on joining the video conference or calling in by phone
15810	Southline Boston (fka 135 Morrissey Boulevard)	BOSTON	05/02/2022	10:00 am	Meet at the site: 135 Morrissey Boulevard, Dorchester
15810	Southline Boston (fka 135 Morrissey Boulevard)	BOSTON	05/03/2022	5:00 pm	REMOTE MEETING. Please RSVP to alexander.strysky@mass.gov at least one hour before the meeting for instructions on joining the video conference or calling in by phone
16547	Alexan Chelmsford	CHELMSFORD	05/10/2022	2:00 pm	REMOTE MEETING. Please RSVP to

						purvi.patel@mass.gov at least one hour before the meeting for instructions on joining the video conference or calling in by phone.
--	--	--	--	--	--	--

Projects Submitted - Environmental Impact Reports

EEA No.	Project Name	Municipality	Document Type	Comments Due	For Copies	MEPA Analyst
---------	--------------	--------------	---------------	--------------	------------	--------------

Projects Submitted - Notices of Project Change

EEA No.	Project Name	Municipality	Document Type	Comments Due	For Copies	MEPA Analyst
16195	Boynton Yards	SOMERVILLE	NPC	05/16/2022	Lauren DeVoe (617) 607-0091 Ldevoe@vhb.com	Eva Murray, (857)408-6381, eva.murray@mass.gov
16439	Witch City Gardens LLC	SALEM	NPC	05/16/2022	Susan St. Pierre (781) 439-2461 sst.pierre@comcast.net	Christina Lyons, , Christina.Lyons@mass.gov

Projects Submitted - Special Review Procedure Request

EEA No.	Project Name	Municipality	Document Type	Comments Due	For Copies	MEPA Analyst
---------	--------------	--------------	---------------	--------------	------------	--------------

Projects Under Review - Environmental Notification Forms

EEA No.	Project Name	Municipality	Document Type	Comments Due	For Copies	MEPA Analyst
16536	Alden Fire Station	REVERE	EENF	04/22/2022	Chris Emilius (781) 273-3434 cemilius@brennanconsults.com	Alexander Strysky, (857)408-6957, alexander.strysky@mass.gov
16537	Littleton Sewer System Expansion Project	LITTLETON	EENF	04/22/2022	Corey Godfrey (617) 452-6597 lofstedtmh@cdmsmith.com	Jennifer Hughes, , Jennifer.Hughes@mass.gov
16538	Plymouth Long Beach Mixed-Sediment	PLYMOUTH	EENF	04/22/2022	Jermy Packard (508) 488-0928 jeramy.packard@foth.com	Christina Lyons, , Christina.Lyons@mass.gov

	Nourishment					
16539	8 Newell Street	SCITUATE	ENF	06/07/2022	Paul Seaberg (781) 585-2300 Paul@GradyConsulting.com	Jennifer Hughes,, Jennifer.Hughes@mass.gov
16542	MVRTA Riverbank Stabilization Project	HAVERTHILL	EENF	05/09/2022	Daniel Bourdeau (508) 472-9538 DBourdeau@geosyntec.com	Jennifer Hughes,, Jennifer.Hughes@mass.gov
16543	Reed Brothers Farm	DIGHTON	ENF	04/28/2022	Greg Drake (508) 946-9231 gdrake@outback-eng.com	Christina Lyons,, Christina.Lyons@mass.gov
16544	Kelsey Road over Dry Brook	SHEFFIELD	ENF	04/28/2022	Sara Kreisel (617) 896-4579 skreisel@bscgroup.com	Christina Lyons,, Christina.Lyons@mass.gov
16545	Lower Artichoke Dam Spillway Protection	NEWBURYPORT	ENF	04/28/2022	Tracy Adamski (413) 572-3256 TJAdamski@TigheBond.com	Christina Lyons,, Christina.Lyons@mass.gov
16546	Highland Science Center	NEEDHAM	ENF	04/28/2022	Samhita Saquib (617) 607-2147 ssaquib@vhb.com	Jennifer Hughes,, Jennifer.Hughes@mass.gov

Projects Under Review - Environmental Impact Reports

EEA No.	Project Name	Municipality	Document Type	Comments Due	For Copies	MEPA Analyst
13940	ADM Tihonet Mixed Use Development	CARVER, PLYMOUTH, WAREHAM	FEIR	05/23/2022	Stacy Minihane (508) 366-0560 sminihane@bealsandthomas.com	Alexander Strysky, (857)408-6957, alexander.strysky@mass.gov
16209	Bowen's	WENDELL	Single EIR	05/09/2022	Nick Wildman	Eva Murray,

	Pond Dam Removal and Osgood Brook Restoration				(617) 626-1527 nick.wildman@mass.gov	(857)408-6381, eva.murray@mass.gov
16307	119 Braintree Street Redevelopment	BOSTON	DEIR	04/22/2022	David Hewett (978) 897-7100 dhewett@epsilonnassociates.com	Erin Flaherty, (617)874-0589, erin.flaherty@mass.gov
16311	Aries Taunton Biosolids Gasification Project	TAUNTON	DEIR	05/18/2022	Corinne Snowdon (978) 897-7100 csnowdon@epsilonnassociates.com	Alexander Strycky, (857)408-6957, alexander.strycky@mass.gov
16408	Auburn Commerce Park	AUBURN	FEIR	05/09/2022	Clayton Williams (978) 460-0133 cwilliams@eastlandpartners.com	Jennifer Hughes, Jennifer.Hughes@mass.gov
16469	Oxford Logistics Center	OXFORD	DEIR	05/09/2022	David Hewett (978) 897-7100 dhewett@epsilonnassociates.com	Eva Murray, (857)408-6381, eva.murray@mass.gov

Projects Under Review - Notices of Project Change

EEA No.	Project Name	Municipality	Document Type	Comments Due	For Copies	MEPA Analyst
8161	BMIP/ Raymond L. Flynn Marine Park Master Plan	BOSTON	PCN	06/10/2022	Richard McGuinness richard.mcguinness@boston.gov	Alexander Strycky, (857)408-6957, alexander.strycky@mass.gov
8161	BMIP/ Raymond L. Flynn	BOSTON	NPC	06/10/2022	Richard McGuinness	Alexander Strycky, (857)408-6957, alexander.strycky

	Marine Park Master Plan				richard.mcguinness@boston.gov	y@mass.gov
15810	Southline Boston (fka 135 Morrissey Boulevard)	BOSTON	ExNPC	05/09/2022	Erik Rexford (978) 897-7100 erexford@epsilonnassociates.com	Alexander Strycky, (857)408-6957, alexander.strycky@mass.gov
15859	Reconstruction of Highland Avenue, Needham Street, and Charles River Bridge, N-04-002	NEWTON, NEEDHAM	NPC	04/28/2022	Rick McCullough (508) 450-6783 rick.mccullough@state.ma.us	Jennifer Hughes, Jennifer.Hughes@mass.gov
15948	Cold Brook Eco-Restoration Project	HARWICH	ExNPC	05/09/2022	Nick Nelson (617) 852-7744 nnelson@interfluve.com	Eva Murray, (857)408-6381, eva.murray@mass.gov
13403/11671	Upland Woods Redevelopment	NORWOOD	NPC	05/09/2022	David Kelly (781) 843-4333 dkelly@kellyengineeringgroup.com	Eva Murray, (857)408-6381, eva.murray@mass.gov

Projects Under Review - Special Review Procedure Request

EEA No.	Project Name	Municipality	Document Type	Comments Due	For Copies	MEPA Analyst
---------	--------------	--------------	---------------	--------------	------------	--------------

Secretary's Certificates - Environmental Notification Forms

EEA No.	Project Name	Municipality	Document Type	Action	Action Date
16510	Sudbury Comprehensive Wastewater Management Plan	SUDBURY	EENF Cert	Requires an Environmental Impact Report	04/01/2022
16522	Wings Way	SANDWICH	ENF Cert	Does not require an Environmental	04/15/2022

				Impact Report	
16523	McKinstry Pond Dam Repairs	OXFORD	EENF Cert	Requires an Environmental Impact Report	04/15/2022
16526	4054 Mystic Valley Parkway	MEDFORD	EENF Cert	Requires an Environmental Impact Report	04/01/2022
16527	Tyngsborough Warehouse Development	TYNGSBOROUGH	ENF Cert	Requires a Single Environmental Impact Report	04/08/2022
16528	Town of Sandwich Boardwalk Restoration Project	SANDWICH	ENF Cert	Does not require an Environmental Impact Report	04/08/2022
16530	540R Main Street	ACUSHNET	ENF Cert	Requires an Environmental Impact Report	04/08/2022
16531	Florence Roche School	GROTON	ENF Cert	Does not require an Environmental Impact Report	04/08/2022
16532	Goodridge Brook Estates	LANCASTER	ENF Cert	Requires an Environmental Impact Report	04/08/2022
16533	Alexan Peabody	PEABODY	ENF Cert	Requires an Environmental Impact Report	04/08/2022

Secretary's Certificates - Environmental Impact Reports

EEA No.	Project Name	Municipality	Document Type	Action	Action Date
---------	--------------	--------------	---------------	--------	-------------

Secretary's Certificates - Notices of Project Change

EEA No.	Project Name	Municipality	Document Type	Action	Action Date
14659	Yarmouth Comprehensive Wastewater Management Plan	YARMOUTH	NPC Cert	Requires an Environmental Impact Report	04/15/2022
16391	500 Thurston Street (fka Proposed Convenience Store and Gas Station and Proposed Warehouse)	WRENTHAM	PCN CERT	Does not require an Environmental Impact Report	04/08/2022

Secretary's Certificates - Records of Decision

EEA No.	Project Name	Municipality	Document Type	Comments Due	Action	Action Date
---------	--------------	--------------	---------------	--------------	--------	-------------

Secretary's Certificates - Special Review Procedures

EEA No.	Project Name	Municipality	Document Type	Action	Action Date
---------	--------------	--------------	---------------	--------	-------------

Secretary's Certificates - Public Benefits Determinations

EEA No.	Project Name	Municipality	Document Type	Action	Action Date
---------	--------------	--------------	---------------	--------	-------------

Secretary's Certificates - Advisory Opinions

EEA No.	Project Name	Municipality	Action	Action Date
---------	--------------	--------------	--------	-------------

Requests for Advisory Opinions

Project Name	Municipality	Comments Due	MEPA Analyst
Sediment Removal at Point of Pines Outfall	REVERE	04/28/2022	Page Czepiga, (857)408-7049, page.czepiga@mass.gov
Petition for Fail-Safe Review re: MBTA Removal of Catenary Wire and Trolley Buses	CAMBRIDGE	04/28/2022	Tori Kim, (857)207-2996, tori.kim@mass.gov
Northeast Metropolitan Regional Vocational Technical High School Project	WAKEFIELD	04/28/2022	Tori Kim, (857)207-2996, tori.kim@mass.gov

Public Notices

Notice Type	Municipality	Agency
Notice of Issuance of a Section 61 Finding- 16386 53 Sturbridge Road	Charlton	MassDEP
Notice of Intent to Initiate an Aquatic Plant Management Program-	Watertown	Conservation Commission
Notice of Intent to Initiate an Aquatic Plant Management Program-	Sheffield	Conservation Commission
Notice of Application for a Water Management Act Permit-	Charles River Basin, Buzzards Bay Basin	MassDEP
Notice of Application for a 401 Water Quality Certificate-	Saugus	MassDEP
Notice of Application for a 401 Water Quality Certificate-	Norwood	MassDEP
Notice of Public Hearing re: Vegetation Management Plan-	Canton	MDAR
Notice of Application for a 401 Water Quality Certificate-	Agawam	MassDEP
Notice of Intent to Initiate an Aquatic Plant Management Program-	Boston	Conservation Commission
Notice of Application for a 401 Water Quality	Norton, Mansfield	MassDEP

Certificate-		
Notice of Intent to Initiate an Aquatic Plant Management Program-	Needham	Conservation Commission
Notice of Intent to Initiate an Aquatic Plant Management Program-	Waltham	Conservation Commission
Notice of Application and Issuance of a Draft Groundwater Discharge Permit-	Westford	MassDEP
Notice of Application and Issuance of a Draft Groundwater Discharge Permit-	Yarmouth	MassDEP
Notice of Application for a 401 Water Quality Certificate-	Waltham	MassDEP
Notice of Submission of a Yearly Operational Plan-	Medway	MDAR
Notice of Intent to Initiate an Aquatic Plant Management Program-	Newton	Conservation Commission
Notice of Intent to Initiate an Aquatic Plant Management Program-	Holliston	Conservation Commission
Notice of Submission of a Yearly Operational Plan-	Great Barrington, Lenox, Sheffield, Lee, Pittsfield, Stockbridge	MDAR
Notice of Submission of a Yearly Operational Plan-	Canton	MDAR
Notice of Intent to Initiate an Aquatic Plant Management Program-	Weston	Conservation Commission
Notice of Availability of Annual State of the Reservation Report-	Bourne, Mashpee, Sandwich	MA Army National Guard
Notice of Intent to Initiate an Ecological Restoration Project-	West Boylston	Conservation Commission
Notice of Application for a 401 Water Quality Certificate-	West Boylston	MassDEP
Notice of Submission of a Yearly Operational Plan-	Auburn, Blackstone, Dudley, Gardner, Grafton, Holden, Hubbardston, Millbury, Millville, Northbridge, Oxford, Princeton, Seekonk, Sutton, Uxbridge, Webster, Worcester	MDAR
Notice of Intent to Initiate	Sheffield	Conservation

an Aquatic Plant Management Program-		Commission
Notice of Intent to Initiate an Aquatic Plant Management Program-	Barnstable	Conservation Commission

NOTES TO USERS

This map is for use in administering the National Flood Insurance Program. It does not necessarily identify all areas subject to flooding, particularly from local drainage sources of small size. The community map repository should be consulted for possible updated or additional flood hazard information.

To obtain more detailed information in areas where Base Flood Elevations (BFEs) and/or floodways have been determined, users are encouraged to consult the Flood Profiles and Floodway Data and/or Summary of Stillwater Elevations tables contained within the Flood Insurance Study (FIS) report that accompanies this FIRM. Users should be aware that BFEs shown on the FIRM represent rounded whole-foot elevations. These BFEs are intended for flood insurance rating purposes only and should not be used as the sole source of flood elevation information. Accordingly, flood elevation data presented in the FIS report should be utilized in conjunction with the FIRM for purposes of construction and/or floodplain management.

Coastal Base Flood Elevations shown on this map apply only landward of 0.0' North American Vertical Datum of 1988 (NAVD 88). Users of this FIRM should be aware that coastal flood elevations are also provided in the Summary of Stillwater Elevations table in the Flood Insurance Study report for this jurisdiction. Elevations shown in the Summary of Stillwater Elevations table should be used for construction and/or floodplain management purposes when they are higher than the elevations shown on this FIRM.

Boundaries of the floodways were computed at cross sections and interpolated between cross sections. The floodways were based on hydraulic considerations with regard to requirements of the National Flood Insurance Program. Floodway widths and other pertinent floodway data are provided in the Flood Insurance Study report for this jurisdiction.

Certain areas not in Special Flood Hazard Areas may be protected by flood control structures. Refer to Section 2.4 "Flood Protection Measures" of the Flood Insurance Study report for information on flood control structures for this jurisdiction.

The projection used in the preparation of this map was Massachusetts State Plane, mainland zone (FIPSZONE 2001). The horizontal datum was NAD83, GRS1980 spheroid. Differences in datum, spheroid, projection or State Plane zones used in the production of FIRMs for adjacent jurisdictions may result in slight positional differences in map features across jurisdiction boundaries. These differences do not affect the accuracy of the FIRM.

Flood elevations on this map are referenced to the North American Vertical Datum of 1988. These flood elevations must be compared to structure and ground elevations referenced to the same vertical datum. For information regarding conversion between the National Geodetic Vertical Datum of 1929 and the North American Vertical Datum of 1988, visit the National Geodetic Survey website at <http://www.ngs.noaa.gov/> or contact the National Geodetic Survey at the following address:

NGS Information Services
NOAA, NNGS12
National Geodetic Survey
SSAC-3, #6222
1315 East-West Highway
Silver Spring, MD 20910-3282

To obtain current elevation, description, and/or location information for bench marks shown on this map, please contact the Information Services Branch of the National Geodetic Survey at (301) 713-3242, or visit its website at <http://www.ngs.noaa.gov/>.

Base map information shown on this FIRM was derived from digital orthophotography. Base map files were provided in digital form by Massachusetts Geographic Information System (MassGIS). Ortho imagery was produced at a scale of 1:5,000. Aerial photography is dated April 2005.

This map reflects more detailed and up-to-date stream channel configurations than those shown on the previous FIRM for this jurisdiction. The floodplains and floodways that were transferred from the previous FIRM may have been adjusted to conform to these new stream channel configurations. As a result, the Flood Profiles and Floodway Data tables in the Flood Insurance Study report (which contains authoritative hydraulic data) may reflect stream channel distances that differ from what is shown on this map.

Corporate limits shown on this map are based on the best data available at the time of publication. Because changes due to annexations or de-annexations may have occurred after this map was published, map users should contact appropriate community officials to verify current corporate limit locations.

Please refer to the separately printed Map Index for an overview map of the county showing the layout of map panels, community map repository addresses, and a Listing of Communities table containing National Flood Insurance Program dates for each community as well as a listing of the panels on which each community is located.

Contact the FEMA Map Service Center at 1-800-358-9616 for information on available products associated with this FIRM. Available products may include previously issued Letters of Map Change, a Flood Insurance Study report, and/or digital versions of this map. The FEMA Map Service Center may also be reached by Fax at 1-800-358-9620 and its website at <http://www.msc.fema.gov/>.

If you have questions about this map or questions concerning the National Flood Insurance Program in general, please call 1-877-FEMA-MAP (1-877-336-2827) or visit the FEMA website at <http://www.fema.gov/>.

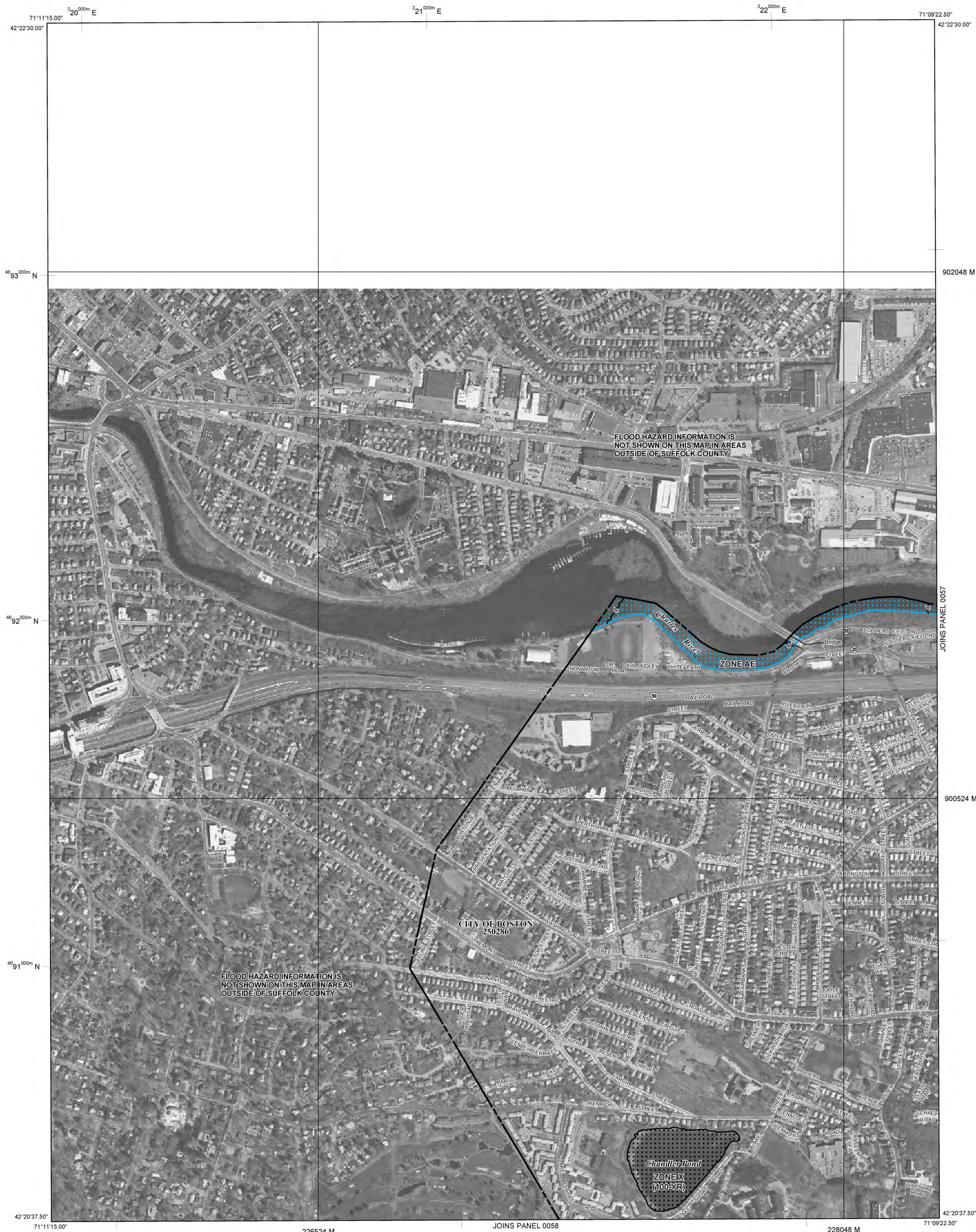

LEGEND

- SPECIAL FLOOD HAZARD AREAS (SFHAs) SUBJECT TO INUNDATION BY THE 1% ANNUAL CHANCE FLOOD**
- The 1% annual chance flood (100-year flood), also known as the base flood, is the flood that has a 1% chance of being equaled or exceeded in any given year. The Special Flood Hazard Area is the area subject to flooding by the 1% annual chance flood. Areas of Special Flood Hazard include Zones A, AE, AH, AO, AR, A99, V and VE. The Base Flood Elevation is the water-surface elevation of the 1% annual chance flood.
- ZONE A** No Base Flood Elevations determined.
 - ZONE AE** Base Flood Elevations determined.
 - ZONE AH** Flood depths of 1 to 3 feet (usually areas of ponding); Base Flood Elevations determined.
 - ZONE AO** Flood depths of 1 to 3 feet (usually sheet flow on sloping terrain); average depths determined. For areas of alluvial fan flooding, velocities also determined.
 - ZONE AR** Special Flood Hazard Area formerly protected from the 1% annual chance flood by a flood control system that was subsequently decertified. Zone AR indicates that the former flood control system is being restored to provide protection from the 1% annual chance or greater flood.
 - ZONE A99** Area to be protected from 1% annual chance flood by a Federal flood protection system under construction; no Base Flood Elevations determined.
 - ZONE V** Coastal flood zone with velocity hazard (wave action); no Base Flood Elevations determined.
 - ZONE VE** Coastal flood zone with velocity hazard (wave action); Base Flood Elevations determined.
- FLOODWAY AREAS IN ZONE AE**
- The floodway is the channel of a stream plus any adjacent floodplain areas that must be kept free of encroachment so that the 1% annual chance flood can be carried without substantial increases in flood heights.
- OTHER FLOOD AREAS**
 - ZONE X** Areas of 0.2% annual chance flood; areas of 1% annual chance flood with average depths of less than 1 foot or with drainage areas less than 1 square mile; and areas protected by levees from 1% annual chance flood.
 - OTHER AREAS**
 - ZONE X** Areas determined to be outside the 0.2% annual chance floodplain.
 - ZONE D** Areas in which flood hazards are undetermined, but possible.
 - COASTAL BARRIER RESOURCES SYSTEM (CBRS) AREAS**
 - OTHERWISE PROTECTED AREAS (OPAs)**
- CBRS areas and OPAs are normally located within or adjacent to Special Flood Hazard Areas.
- 1% annual chance floodplain boundary
 - 0.2% annual chance floodplain boundary
 - Floodway boundary
 - Zone D boundary
 - CBRS and OPA boundary
 - Boundary dividing Special Flood Hazard Areas of different Base Flood Elevations, flood depths or flood velocities.
 - Base Flood Elevation line and value; elevation in feet*
 - Base Flood Elevation value where uniform within zone; elevation in feet*
- * Referenced to the North American Vertical Datum of 1988 (NAVD 88)
- (A) Cross section line
 - (23) - - - - (23) Transect line
 - 97°07'30", 32°22'30" Geographic coordinates referenced to the North American Datum of 1983 (NAD 83)
 - 4750000 N 1000-meter Universal Transverse Mercator grid, zone 19
 - 6000000 M Massachusetts State Plane coordinate system, mainland zone (FIPSZONE 2001), Lambert Conformal Conic
 - DX5510 Bench mark (see explanation in Notes to Users section of this FIRM panel)
 - M1.5 River Mile
- MAP REPOSITORIES**
Refer to Map Repositories list on Map Index.
- EFFECTIVE DATE OF COUNTYWIDE FLOOD INSURANCE RATE MAP**
September 25, 2009
- EFFECTIVE DATE(S) OF REVISION(S) TO THIS PANEL**

NATIONAL FLOOD INSURANCE PROGRAM

PANEL 0056G

FIRM
FLOOD INSURANCE RATE MAP
SUFFOLK COUNTY,
MASSACHUSETTS
(ALL JURISDICTIONS)

PANEL 56 OF 151
(SEE MAP INDEX FOR FIRM PANEL LAYOUT)

CONTAINS:	NUMBER	PANEL	SUFFIX
BOSTON, CITY OF	250286	0056	G

Notice to User: The Map Number shown below should be used when placing map orders; the Community Number shown above should be used on insurance applications for the subject community.

MAP NUMBER
25025C0056G

EFFECTIVE DATE
SEPTEMBER 25, 2009

Federal Emergency Management Agency

NOTES TO USERS

This map is for use in administering the National Flood Insurance Program. It does not necessarily identify all areas subject to flooding, particularly from local drainage sources of small size. The community map repository should be consulted for possible updated or additional flood hazard information.

To obtain more detailed information in areas where Base Flood Elevations (BFEs) and/or floodways have been determined, users are encouraged to consult the Flood Profiles and Floodway Data and/or Summary of Stillwater Elevations tables contained within the Flood Insurance Study (FIS) report that accompanies this FIRM. Users should be aware that BFEs shown on the FIRM represent rounded whole-foot elevations. These BFEs are intended for flood insurance rating purposes only and should not be used as the sole source of flood elevation information. Accordingly, flood elevation data presented in the FIS report should be utilized in conjunction with the FIRM for purposes of construction and/or floodplain management.

Coastal Base Flood Elevations shown on this map apply only landward of 0.0' North American Vertical Datum of 1988 (NAVD 88). Users of this FIRM should be aware that coastal flood elevations are also provided in the Summary of Stillwater Elevations table in the Flood Insurance Study report for this jurisdiction. Elevations shown in the Summary of Stillwater Elevations table should be used for construction and/or floodplain management purposes when they are higher than the elevations shown on this FIRM.

Boundaries of the floodways were computed at cross sections and interpolated between cross sections. The floodways were based on hydraulic considerations with regard to requirements of the National Flood Insurance Program. Floodway widths and other pertinent floodway data are provided in the Flood Insurance Study report for this jurisdiction.

Certain areas not in Special Flood Hazard Areas may be protected by flood control structures. Refer to Section 2.4 "Flood Protection Measures" of the Flood Insurance Study report for information on flood control structures for this jurisdiction.

The projection used in the preparation of this map was Massachusetts State Plane - mainland zone (FIPSZONE 2001). The horizontal datum was NAD83, GRS1980 spheroid. Differences in datum, spheroid, projection or State Plane zones used in the production of FIRMs for adjacent jurisdictions may result in slight positional differences in map features across jurisdiction boundaries. These differences do not affect the accuracy of the FIRM.

Flood elevations on this map are referenced to the North American Vertical Datum of 1988. These flood elevations must be compared to structure and ground elevations referenced to the same vertical datum. For information regarding conversion between the National Geodetic Vertical Datum of 1929 and the North American Vertical Datum of 1988, visit the National Geodetic Survey website at <http://www.ngs.noaa.gov/> or contact the National Geodetic Survey at the following address:

NGS Information Services
NOAA, NNGS12
National Geodetic Survey
SSM-C-3, #6292
1315 East-West Highway
Silver Spring, MD 20910-3282

To obtain current elevation, description, and/or location information for bench marks shown on this map, please contact the Information Services Branch of the National Geodetic Survey at (301) 713-3242, or visit its website at <http://www.ngs.noaa.gov/>.

Base map information shown on this FIRM was derived from digital orthophotography. Base map files were provided in digital form by Massachusetts Geographic Information System (MassGIS). Ortho imagery was produced at a scale of 1:5,000. Aerial photography is dated April 2005.

This map reflects more detailed and up-to-date stream channel configurations than those shown on the previous FIRM for this jurisdiction. The floodplains and floodways that were transferred from the previous FIRM may have been adjusted to conform to these new stream channel configurations. As a result, the Flood Profiles and Floodway Data tables in the Flood Insurance Study report (which contains authoritative hydraulic data) may reflect stream channel distances that differ from what is shown on this map.

Corporate limits shown on this map are based on the best data available at the time of publication. Because changes due to annexations or de-annexations may have occurred after this map was published, map users should contact appropriate community officials to verify current corporate limit locations.

Please refer to the separately printed Map Index for an overview map of the county showing the layout of map panels, community map repository addresses, and a Listing of Communities table containing National Flood Insurance Program dates for each community as well as a listing of the panels on which each community is located.

Contact the FEMA Map Service Center at 1-800-358-9616 for information on available products associated with this FIRM. Available products may include previously issued Letters of Map Change, a Flood Insurance Study report, and/or digital versions of this map. The FEMA Map Service Center may also be reached by Fax at 1-800-358-9620 and its website at <http://www.msc.fema.gov/>.

If you have questions about this map or questions concerning the National Flood Insurance Program in general, please call 1-877-FEMA-MAP (1-877-336-2627) or visit the FEMA website at <http://www.fema.gov/>.

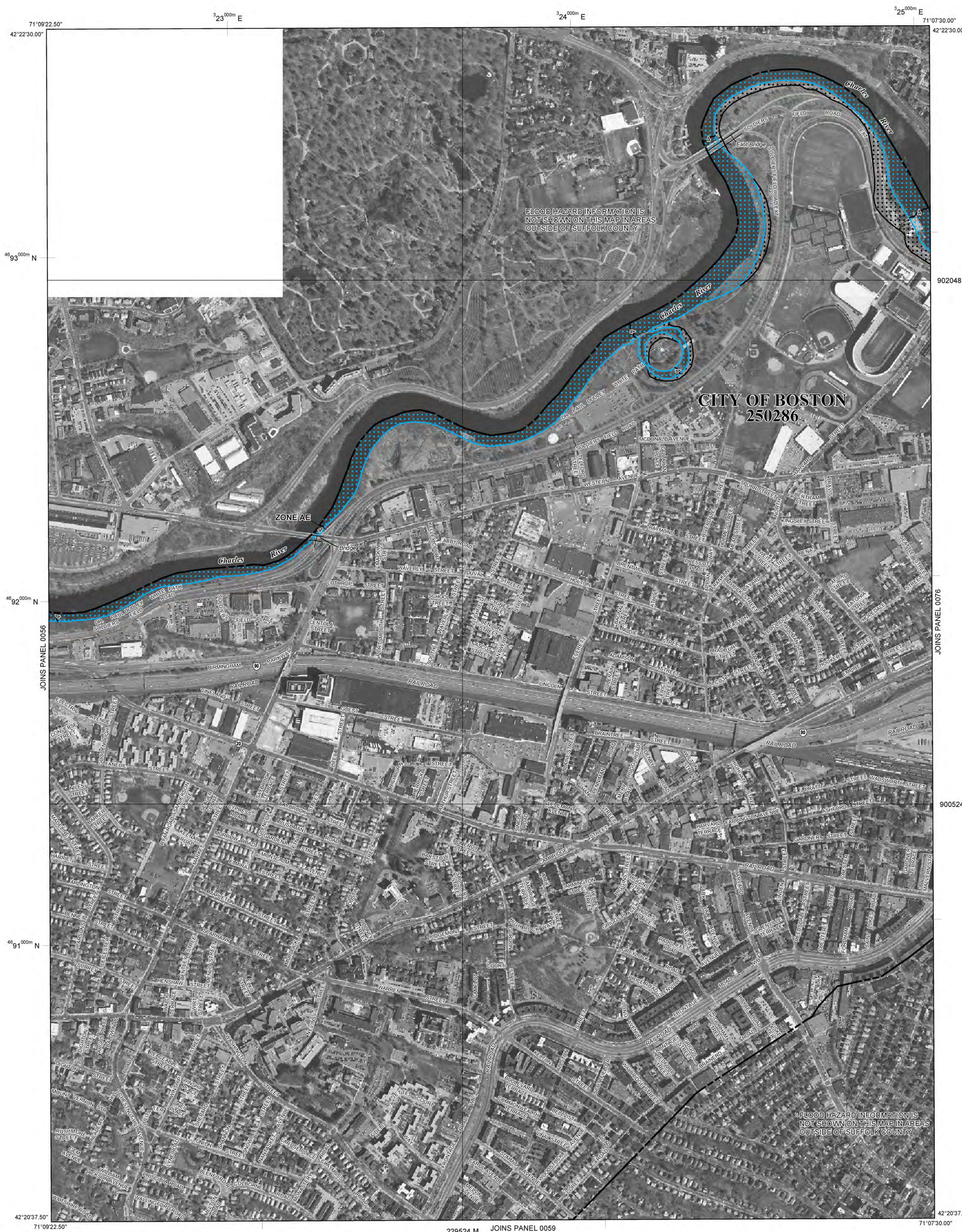

LEGEND

SPECIAL FLOOD HAZARD AREAS (SFHAs) SUBJECT TO INUNDATION BY THE 1% ANNUAL CHANCE FLOOD

The 1% annual chance flood (100-year flood), also known as the base flood, is the flood that has a 1% chance of being equaled or exceeded in any given year. The Special Flood Hazard Area is the area subject to flooding by the 1% annual chance flood. Areas of Special Flood Hazard include Zones A, AE, AH, AO, AR, A99, V and VE. The Base Flood Elevation is the water-surface elevation of the 1% annual chance flood.

ZONE A No Base Flood Elevations determined.

ZONE AE Base Flood Elevations determined.

ZONE AH Flood depths of 1 to 3 feet (usually areas of ponding); Base Flood Elevations determined.

ZONE AO Flood depths of 1 to 3 feet (usually sheet flow on sloping terrain); average depths determined. For areas of alluvial fan flooding, velocities also determined.

ZONE AR Special Flood Hazard Area formerly protected from the 1% annual chance flood by a flood control system that was subsequently decertified. Zone AR indicates that the former flood control system is being restored to provide protection from the 1% annual chance or greater flood.

ZONE A99 Area to be protected from 1% annual chance flood by a Federal flood protection system under construction; no Base Flood Elevations determined.

ZONE V Coastal flood zone with velocity hazard (wave action); no Base Flood Elevations determined.

ZONE VE Coastal flood zone with velocity hazard (wave action); Base Flood Elevations determined.

FLOODWAY AREAS IN ZONE AE

The floodway is the channel of a stream plus any adjacent floodplain areas that must be kept free of encroachment so that the 1% annual chance flood can be carried without substantial increases in flood heights.

OTHER FLOOD AREAS

ZONE X Areas of 0.2% annual chance flood; areas of 1% annual chance flood with average depths of less than 1 foot or with drainage areas less than 1 square mile; and areas protected by levees from 1% annual chance flood.

OTHER AREAS

ZONE X Areas determined to be outside the 0.2% annual chance floodplain.

ZONE D Areas in which flood hazards are undetermined, but possible.

COASTAL BARRIER RESOURCES SYSTEM (CBRS) AREAS

OTHERWISE PROTECTED AREAS (OPAs)

CBRS areas and OPAs are normally located within or adjacent to Special Flood Hazard Areas.

1% annual chance floodplain boundary
0.2% annual chance floodplain boundary
Floodway boundary
Zone D boundary
CBRS and OPA boundary
Boundary dividing Special Flood Hazard Areas of different Base Flood Elevations, flood depths or flood velocities.
Base Flood Elevation line and value; elevation in feet*
Base Flood Elevation value where uniform within zone; elevation in feet*
* Referenced to the North American Vertical Datum of 1988 (NAVD 88)

MAP REPOSITORIES
Refer to Map Repositories list on Map Index.

EFFECTIVE DATE OF COUNTY-WIDE FLOOD INSURANCE RATE MAP
September 25, 2006

EFFECTIVE DATE(S) OF REVISION(S) TO THIS PANEL

For community map revision history prior to countywide mapping, refer to the Community Map History table located in the Flood Insurance Study report for this jurisdiction.

To determine if flood insurance is available in this community, contact your insurance agent or call the National Flood Insurance Program at 1-800-638-6620.

MAP SCALE 1" = 600'

250 0 500 1000 FEET
150 0 150 300 METERS

NFIP

NATIONAL FLOOD INSURANCE PROGRAM

PANEL 0057G

FIRM

FLOOD INSURANCE RATE MAP

SUFFOLK COUNTY, MASSACHUSETTS (ALL JURISDICTIONS)

PANEL 57 OF 151
(SEE MAP INDEX FOR FIRM PANEL LAYOUT)

CONTAINS:	NUMBER	PANEL	SUFFIX
COMMUNITY	250286	0057	G
BOSTON, CITY OF			

MAP NUMBER
25025C0057G

EFFECTIVE DATE
SEPTEMBER 25, 2006

FEDERAL EMERGENCY MANAGEMENT AGENCY

-NOTE- THIS MAP INCLUDES BOUNDARIES OF THE COASTAL BARRIER RESOURCES SYSTEM ESTABLISHED UNDER THE COASTAL BARRIER RESOURCES ACT OF 1982 AND/OR SUBSEQUENT ENABLING LEGISLATION.

Notice to User: The Map Number shown below should be used when placing map orders. The Community Number shown above should be used on insurance applications for the subject community.

NOTES TO USERS

This map is for use in administering the National Flood Insurance Program. It does not necessarily identify all areas subject to flooding, particularly from local drainage sources of small size. The community map repository should be consulted for possible updated or additional flood hazard information.

To obtain more detailed information in areas where Base Flood Elevations (BFEs) and/or floodways have been determined, users are encouraged to consult the Flood Profiles and Floodway Data and/or Summary of Stillwater Elevations tables contained within the Flood Insurance Study (FIS) report that accompanies this FIRM. Users should be aware that BFEs shown on the FIRM represent rounded whole-foot elevations. These BFEs are intended for flood insurance rating purposes only and should not be used as the sole source of flood elevation information. Accordingly, flood elevation data presented in the FIS report should be utilized in conjunction with the FIRM for purposes of construction and/or floodplain management.

Coastal Base Flood Elevations shown on this map apply only landward of 0.0' North American Vertical Datum of 1988 (NAVD 88). Users of this FIRM should be aware that coastal flood elevations are also provided in the Summary of Stillwater Elevations table in the Flood Insurance Study report for this jurisdiction. Elevations shown in the Summary of Stillwater Elevations table should be used for construction and/or floodplain management purposes when they are higher than the elevations shown on this FIRM.

Boundaries of the floodways were computed at cross sections and interpolated between cross sections. The floodways were based on hydraulic considerations with regard to requirements of the National Flood Insurance Program. Floodway widths and other pertinent floodway data are provided in the Flood Insurance Study report for this jurisdiction.

Certain areas not in Special Flood Hazard Areas may be protected by flood control structures. Refer to Section 2.4 "Flood Protection Measures" of the Flood Insurance Study report for information on flood control structures for this jurisdiction.

The projection used in the preparation of this map was Massachusetts State Plane, mainland zone (FIPSZONE 2001). The horizontal datum was NAD83, CRS1980 spheroid. Differences in datum, spheroid, projection or State Plane zones used in the production of FIRMs for adjacent jurisdictions may result in slight positional differences in map features across jurisdiction boundaries. These differences do not affect the accuracy of the FIRM.

Flood elevations on this map are referenced to the North American Vertical Datum of 1988. These flood elevations must be compared to structure and ground elevations referenced to the same vertical datum. For information regarding conversion between the National Geodetic Vertical Datum of 1929 and the North American Vertical Datum of 1988, visit the National Geodetic Survey website at <http://www.ngs.noaa.gov/> or contact the National Geodetic Survey at the following address:

NGS Information Services
NOAA, NNGS12
National Geodetic Survey
SSM-C-3, #6222
1315 East-West Highway
Silver Spring, MD 20910-3282

To obtain current elevation, description, and/or location information for bench marks shown on this map, please contact the Information Services Branch of the National Geodetic Survey at (301) 713-3242, or visit its website at <http://www.ngs.noaa.gov/>.

Base map information shown on this FIRM was derived from digital orthophotography. Base map files were provided in digital form by Massachusetts Geographic Information System (MassGIS). Ortho imagery was produced at a scale of 1:5,000. Aerial photography is dated April 2005.

This map reflects more detailed and up-to-date stream channel configurations than those shown on the previous FIRM for this jurisdiction. The floodplains and floodways that were transferred from the previous FIRM may have been adjusted to conform to these new stream channel configurations. As a result, the Flood Profiles and Floodway Data tables in the Flood Insurance Study report (which contains authoritative hydraulic data) may reflect stream channel distances that differ from what is shown on this map.

Corporate limits shown on this map are based on the best data available at the time of publication. Because changes due to annexations or de-annexations may have occurred after this map was published, map users should contact appropriate community officials to verify current corporate limit locations.

Please refer to the separately printed Map Index for an overview map of the county showing the layout of map panels, community map repository addresses, and a Listing of Communities table containing National Flood Insurance Program dates for each community as well as a listing of the panels on which each community is located.

Contact the FEMA Map Service Center at 1-800-358-9616 for information on available products associated with this FIRM. Available products may include previously issued Letters of Map Change, a Flood Insurance Study report, and/or digital versions of this map. The FEMA Map Service Center may also be reached by Fax at 1-800-358-9620 and its website at <http://www.msc.fema.gov/>.

If you have questions about this map or questions concerning the National Flood Insurance Program in general, please call 1-877-FEMA-MAP (1-877-336-2827) or visit the FEMA website at <http://www.fema.gov/>.

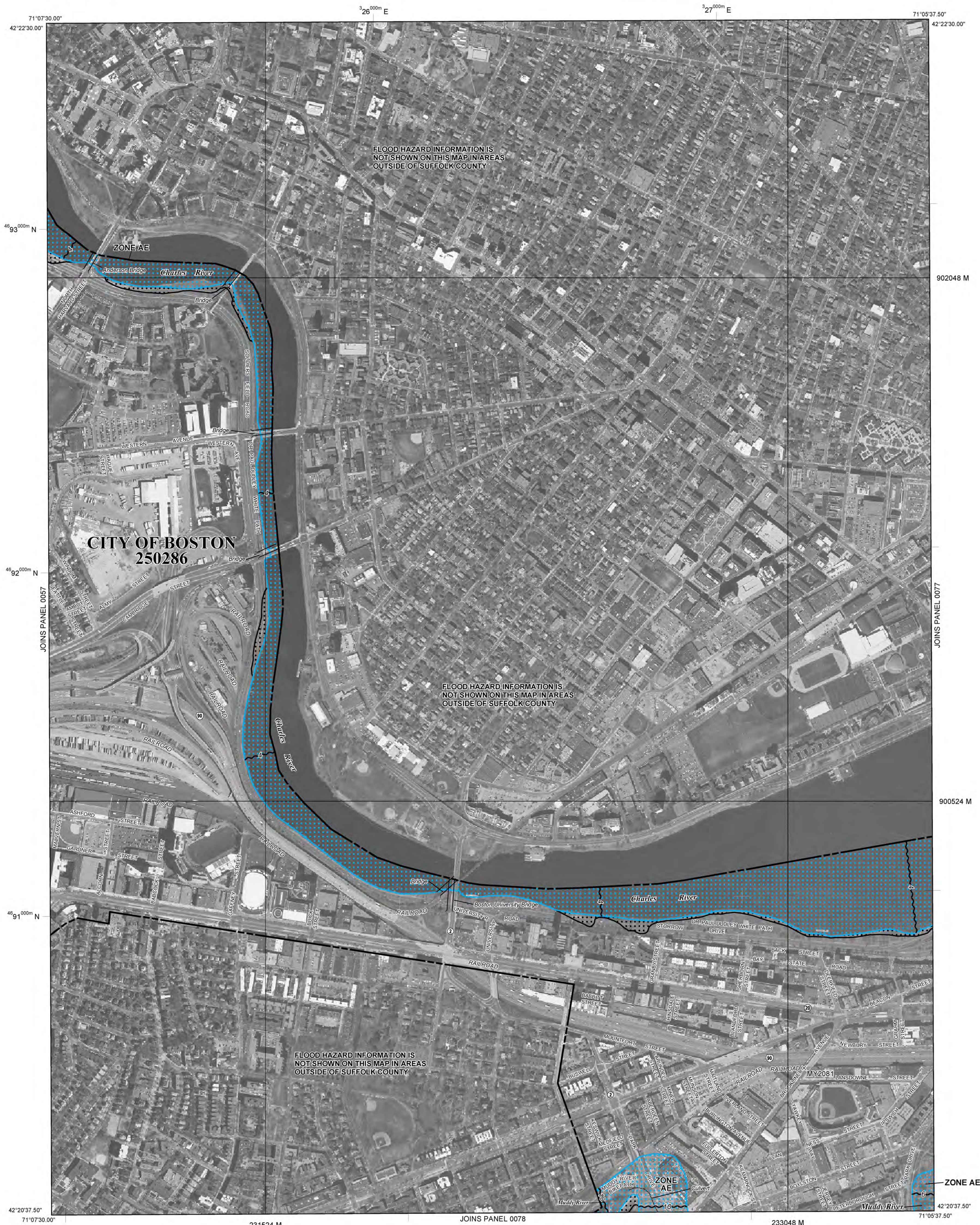

LEGEND

SPECIAL FLOOD HAZARD AREAS (SFHAs) SUBJECT TO INUNDATION BY THE 1% ANNUAL CHANCE FLOOD

The 1% annual chance flood (100-year flood), also known as the base flood, is the flood that has a 1% chance of being equalled or exceeded in any given year. The Special Flood Hazard Area is the area subject to flooding by the 1% annual chance flood. Areas of Special Flood Hazard include Zones A, AE, AH, AO, AR, A99, V and VE. The Base Flood Elevation is the water-surface elevation of the 1% annual chance flood.

ZONE A No Base Flood Elevations determined.

ZONE AE Base Flood Elevations determined.

ZONE AH Flood depths of 1 to 3 feet (usually areas of ponding); Base Flood Elevations determined.

ZONE AO Flood depths of 1 to 3 feet (usually sheet flow on sloping terrain); average depths determined. For areas of alluvial fan flooding, velocities also determined.

ZONE AR Special Flood Hazard Area formerly protected from the 1% annual chance flood by a flood control system that was subsequently decertified. Zone AR indicates that the former flood control system is being restored to provide protection from the 1% annual chance or greater flood.

ZONE A99 Area to be protected from 1% annual chance flood by a Federal flood protection system under construction; no Base Flood Elevations determined.

ZONE V Coastal flood zone with velocity hazard (wave action); no Base Flood Elevations determined.

ZONE VE Coastal flood zone with velocity hazard (wave action); Base Flood Elevations determined.

FLOODWAY AREAS IN ZONE AE

The floodway is the channel of a stream plus any adjacent floodplain areas that must be kept free of encroachment so that the 1% annual chance flood can be carried without substantial increases in flood heights.

OTHER FLOOD AREAS

ZONE X Areas of 0.2% annual chance flood; areas of 1% annual chance flood with average depths of less than 1 foot or with drainage areas less than 1 square mile; and areas protected by levees from 1% annual chance flood.

OTHER AREAS

ZONE X Areas determined to be outside the 0.2% annual chance floodplain.

ZONE D Areas in which flood hazards are undetermined, but possible.

COASTAL BARRIER RESOURCES SYSTEM (CBRS) AREAS

OTHERWISE PROTECTED AREAS (OPAs)

CBRS areas and OPAs are normally located within or adjacent to Special Flood Hazard Areas.

- 1% annual chance floodplain boundary
- 0.2% annual chance floodplain boundary
- Floodway boundary
- Zone D boundary
- CBRS and OPA boundary
- Boundary dividing Special Flood Hazard Areas of different Base Flood Elevations, flood depths or flood velocities.
- Base Flood Elevation line and value; elevation in feet*
- 513 (EL 987) Base Flood Elevation value where uniform within zone; elevation in feet*

* Referenced to the North American Vertical Datum of 1988 (NAVD 88)

A Cross section line

23 Transsect line

97°07'30", 32°22'30" Geographic coordinates referenced to the North American Datum of 1983 (NAD 83)

47°5'00"N 1000-meter Universal Transverse Mercator grid, zone 19

6000000 M Massachusetts State Plane coordinate system, mainland zone (FIPSZONE 2001), Lambert Conformal Conic

DX5510 Bench mark (see explanation in Notes to Users section of this FIRM panel)

M1.5 River Mile

MAP REPOSITORIES
Refer to Map Repositories list on Map Index.

EFFECTIVE DATE OF COUNTYWIDE FLOOD INSURANCE RATE MAP
September 25, 2009

EFFECTIVE DATE(S) OF REVISION(S) TO THIS PANEL

For community map revision history prior to countywide mapping, refer to the Community Map History table located in the Flood Insurance Study report for this jurisdiction.

To determine if flood insurance is available in this community, contact your insurance agent or call the National Flood Insurance Program at 1-800-638-6620.

NFIP

PANEL 0076G

FIRM
FLOOD INSURANCE RATE MAP
SUFFOLK COUNTY,
MASSACHUSETTS
(ALL JURISDICTIONS)

PANEL 76 OF 151
(SEE MAP INDEX FOR FIRM PANEL LAYOUT)

CONTAINS:

COMMUNITY	NUMBER	PANEL	SUFFIX
BOSTON, CITY OF	250286	0076	G

Notice to User: The Map Number shown below should be used when placing map orders; the Community Number shown above should be used on insurance applications for the subject community.

MAP NUMBER
25025C0076G

EFFECTIVE DATE
SEPTEMBER 25, 2009

Federal Emergency Management Agency

NOTES TO USERS

This map is for use in administering the National Flood Insurance Program. It does not necessarily identify all areas subject to flooding, particularly from local drainage sources of small size. The community map repository should be consulted for possible updated or additional flood hazard information.

To obtain more detailed information in areas where **Base Flood Elevations (BFEs)** and/or **floodways** have been determined, users are encouraged to consult the Flood Profiles and Floodway Data and/or Summary of Stillwater Elevations tables contained within the Flood Insurance Study (FIS) Report that accompanies this FIRM. Users should be aware that BFEs shown on the FIRM represent rounded whole-foot elevations. These BFEs are intended for flood insurance rating purposes only and should not be used as the sole source of flood elevation information. Accordingly, flood elevation data presented in the FIS Report should be utilized in conjunction with the FIRM for purposes of construction and/or floodplain management.

Coastal Base Flood Elevations shown on this map apply only landward of 0' North American Vertical Datum of 1988 (NAVD 88). Users of this FIRM should be aware that coastal flood elevations are also provided in the Summary of Stillwater Elevations table in the Flood Insurance Study Report for this jurisdiction. Elevations shown in the Summary of Stillwater Elevations table should be used for construction and/or floodplain management purposes when they are higher than the elevations shown on this FIRM.

Boundaries of the **floodways** were computed at cross sections and interpolated between cross sections. The floodways were based on hydraulic considerations with regard to requirements of the National Flood Insurance Program. Floodway widths and other pertinent floodway data are provided in the Flood Insurance Study Report for this jurisdiction.

The AE Zone category has been divided by a **Limit of Moderate Wave Action (LIMWA)**. The LIMWA represents the approximate landward limit of the 1.5-foot breaking wave. The effects of wave hazards between the VE Zone and the LIMWA (or between the shoreline and the LIMWA for areas where VE Zones are not identified) will be similar to, but less severe than those in the VE Zone.

Certain areas not in Special Flood Hazard Areas may be protected by **flood control structures**. Refer to Section 2.4 "Flood Protection Measures" of the Flood Insurance Study Report for information on flood control structures for this jurisdiction.

The **projection** used in the preparation of this map was Massachusetts State Plane Mainland Zone (FIPS zone 2001). The **horizontal datum** was NAD 83, GRS 1980 spheroid. Differences in datum, spheroid, projection or UTM zones used in the production of FIRMs for adjacent jurisdictions may result in slight positional differences in map features across jurisdiction boundaries. These differences do not affect the accuracy of this FIRM.

Flood elevations on this map are referenced to the North American Vertical Datum of 1988. These flood elevations must be compared to structure and ground elevations referenced to the same vertical datum. For information regarding conversion between the National Geodetic Vertical Datum of 1929 and the North American Vertical Datum of 1988, visit the National Geodetic Survey website at <http://www.ngs.noaa.gov> or contact the National Geodetic Survey at the following address:

NGS Information Services
NOAA, NNGS12
National Geodetic Survey
SSMC-3, #9202
1315 East-West Highway
Silver Spring, Maryland 20910-3282
(301) 713-3242

To obtain current elevation, description, and/or location information for **bench marks** shown on this map, please contact the Information Services Branch of the National Geodetic Survey at (301) 713-3242, or visit its website at <http://www.ngs.noaa.gov>.

Base map information shown on this FIRM is derived from Massachusetts Geographic Information System (MassGIS) digital ortho-photography produced at 45 centimeter (2005) and 30 centimeter (2008) resolution. Aerial photography is dated Spring 2005 and Spring 2008.

The **profile baselines** depicted on this map represent the hydraulic modeling baselines that match the flood profiles in the FIS report. As a result of improved topographic data, the **profile baseline**, in some cases, may deviate significantly from the channel centerline or appear outside the SFHA.

Based on updated topographic information, this map reflects more detailed and up-to-date **stream channel configurations** and **floodplain delineations** than those shown on the previous FIRM for this jurisdiction. As a result, the Flood Profiles and Floodway Data Tables for multiple streams in the Flood Insurance Study Report (which contains authoritative hydraulic data) may reflect stream channel distances that differ from what is shown on the map. Also, the road to floodplain relationships for unrevised streams may differ from what is shown on previous maps.

Corporate limits shown on this map are based on the best data available at the time of publication. Because changes due to annexations or de-annexations may have occurred after this map was published, map users should contact appropriate community officials to verify current corporate limit locations.

Please refer to the separately printed **Map Index** for an overview map of the county showing the layout of map panels, community map repository addresses, and a Listing of Communities table containing National Flood Insurance Program dates for each community as well as a listing of the panels on which each community is located.

For information on available products associated with this FIRM visit the **Map Service Center (MSC)** website at <http://msc.fema.gov>. Available products may include previously issued Letters of Map Change, a Flood Insurance Study Report, and/or digital versions of this map. Many of these products can be ordered or obtained directly from the MSC website.

If you have **questions about this map**, how to order products, or the National Flood Insurance Program in general, please call the **FEMA Map Information eXchange (FMIX)** at 1-877-FEMA-MAP (1-877-336-2627) or visit the FEMA website at <http://www.fema.gov/business/nfp>.

Only coastal structures that are certified to provide protection from the 1-percent-annual-chance flood are shown on this panel. However, all structures taken into consideration for the purpose of coastal flood hazard analysis and mapping are present in the DFIRM database in S_Gen_Struct.



LEGEND

- SPECIAL FLOOD HAZARD AREAS (SFHAs) SUBJECT TO INUNDATION BY THE 1% ANNUAL CHANCE FLOOD. The 1% annual chance flood (100-year flood), also known as the base flood, is the flood that has a 1% chance of being equaled or exceeded in any given year. The Special Flood Hazard Area is the area subject to flooding by the 1% annual chance flood. Areas of Special Flood Hazard include Zones A, AE, AH, AO, AR, A99, V, and VE. The Base Flood Elevation is the water-surface elevation of the 1% annual chance flood.
 - ZONE A** No Base Flood Elevations determined.
 - ZONE AE** Base Flood Elevations determined.
 - ZONE AH** Flood depths of 1 to 3 feet (usually areas of ponding); Base Flood Elevations determined.
 - ZONE AO** Flood depths of 1 to 3 feet (usually sheet flow on sloping terrain); average depths determined. For areas of alluvial fan flooding, velocities also determined.
 - ZONE AR** Special Flood Hazard Areas formerly protected from the 1% annual chance flood by a flood control system that was subsequently described. Zone AR indicates that the former flood control system is being restored to provide protection from the 1% annual chance or greater flood.
 - ZONE A99** Area to be protected from 1% annual chance flood by a Federal flood protection system under construction; no Base Flood Elevations determined.
 - ZONE V** Coastal flood zone with velocity hazard (wave action); no Base Flood Elevations determined.
 - ZONE VE** Coastal flood zone with velocity hazard (wave action); Base Flood Elevations determined.
 - FLOODWAY AREAS IN ZONE AE
- The floodway is the channel of a stream plus any adjacent floodplain areas that must be kept free of encroachment that the 1% annual chance flood can be carried without substantial increases in flood heights.
- OTHER FLOOD AREAS**
 - ZONE X** Areas of 0.2% annual chance flood; areas of 1% annual chance flood with average depths of less than 1 foot or with drainage areas less than 1 square mile; and areas protected by levees from 1% annual chance flood.
 - OTHER AREAS**
 - ZONE X** Areas determined to be outside the 0.2% annual chance floodplain.
 - ZONE D** Areas in which flood hazards are undetermined, but possible.
 - COASTAL BARRIER RESOURCES SYSTEM (CBRS) AREAS
 - OTHERWISE PROTECTED AREAS (OPAs)
- CBRS areas and OPAs are normally located within or adjacent to Special Flood Hazard Areas.
- 1% Annual Chance Floodplain Boundary
 - 0.2% Annual Chance Floodplain Boundary
 - Floodway boundary
 - Zone D boundary
 - CBRS and OPA boundary
 - Boundary dividing Special Flood Hazard Area Zones and boundary dividing Special Flood Hazard Areas of different Base Flood Elevations, flood depths, or flood velocities.
 - Limit of Moderate Wave Action
 - Limit of Moderate Wave Action coincident with Zone Break
 - Base Flood Elevation line and value; elevation in feet*
 - Base Flood Elevation value where uniform within zone; elevation in feet*
- *Referenced to the North American Vertical Datum of 1988

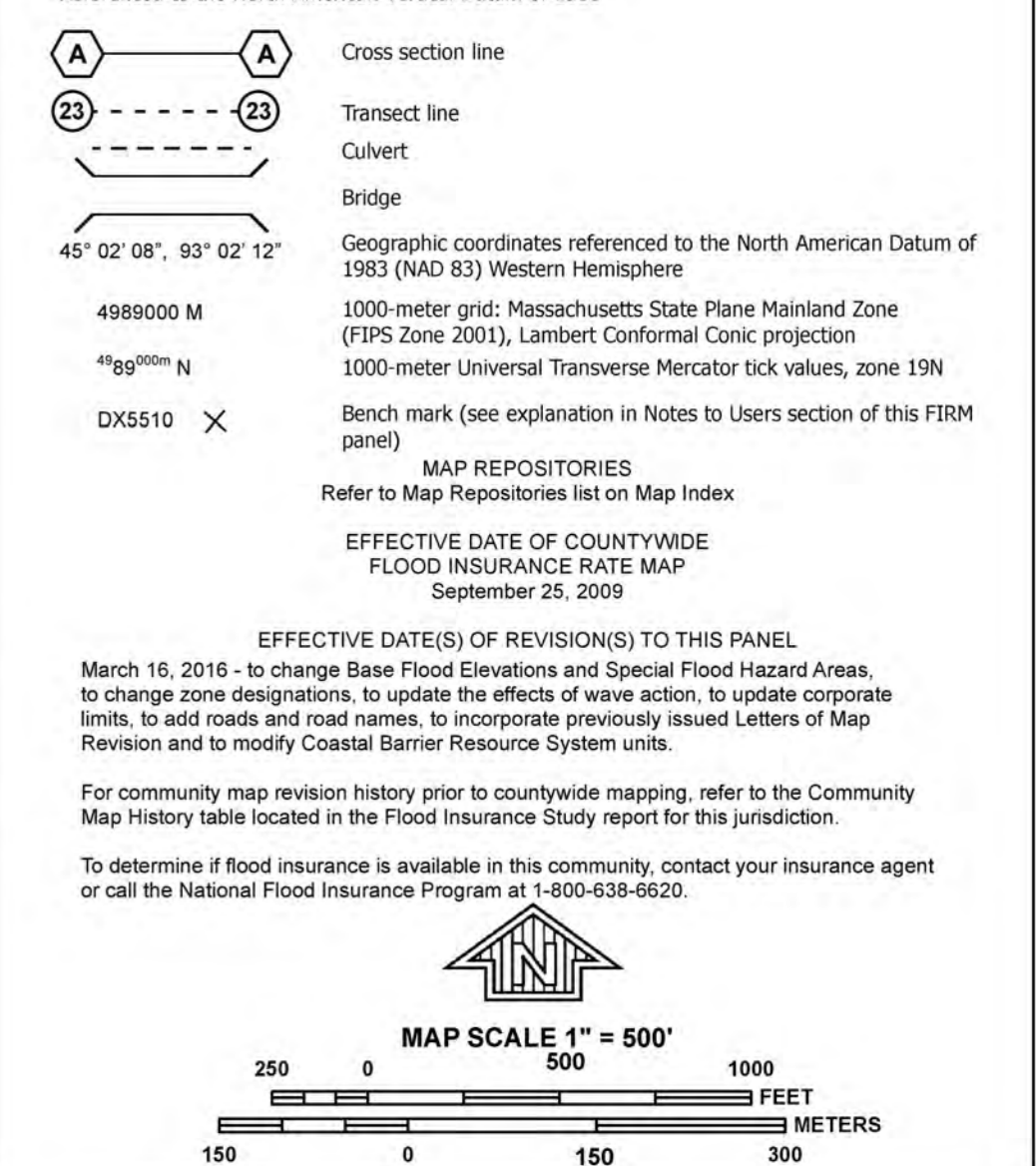

NATIONAL FLOOD INSURANCE PROGRAM

PANEL 0077J

FIRM FLOOD INSURANCE RATE MAP SUFFOLK COUNTY, MASSACHUSETTS (ALL JURISDICTIONS)

PANEL 77 OF 176
(SEE MAP INDEX FOR FIRM PANEL LAYOUT)

CONTAINS:

COMMUNITY	NUMBER	PANEL	SUFFIX
BOSTON, CITY OF	250286	0077	J

Notice to User: The **Map Number** shown below should be used when placing map orders; the **Community Number** shown above should be used on insurance applications for the subject community.

MAP NUMBER 25025C0077J
MAP REVISED MARCH 16, 2016

Federal Emergency Management Agency