



**Ivas Environmental
Environmental Sciences
Wetlands and Planning Services**

**315 Winter Street
Norwell MA 02061-1401
781.659.1690, spivas@comcast.net**

**City of Boston Conservation Commission
Boston City Hall
1 City Hall Square
Boston MA 02201**

10 Nov 21

RE: MA DEP File #: NE - 006-1816, 155 Porter Street, East Boston

Dear Mr./Ms. Chairperson and members of the Commission:

This letter covers the attached package of information provided to the City of Boston Conservation Commission. It is written as a response to Mr. Moreno's comments of 03 Nov 21 regarding the proposed project at 155 Porter Street.

The comments are the following, with responses in **Boldface**.

1. The project is solely within LSCSF and would therefore not be below mean high water. Section C.3. should be checked as "no" and there was no need to send anything to MA DMF.

Please review the attached Section C.3, Page 6 of 9, of the WPA Form 3. Section C. 3 is checked as "no."

2. I am still having difficulty matching the proposed elevations on the Climate Resiliency Checklist to the plan set that was provided. Can you highlight those elevations on the proposed grading plan (C102)?

A. The Climate Resiliency Checklist provides proposed elevations on Page 1, Section A.3 - Project Description and Design Conditions - Site and Building.

B. An 11 x 17 inch print of the Building Sections is included. These are plans A-300, A-301, and A-302. The elevations are found adjacent to the buildings, on the right side, on each plan.

C. An 11 x 17 inch Grading and Utility Plan, numbered C102, is attached that provides callout boxes for the low and high elevations on site. Additionally, these callout boxes have been highlighted in yellow so that they may be easily referenced on the Grading and Utility Plan.

3. I still have a number of issues with the climate narrative as revised. I think it would be most beneficial to discuss these over the phone and as they relate to the comment from MassDEP.



We understand that Utkarsh Patil, Vice President of Operations at Russell and Dawson, has had a productive telcom with N. Moreno, and the resulting revision (09 Nov 21) of the Climate Narrative addresses Mr. Moreno's issues.

Documents that illustrate the comments responses are attached. They are included in the digital file and hard copies are attached to this cover letter.

We posit that the above and attached information fully answers the City of Boston Conservation Commission's questions regarding this redevelopment project. Thank you for reviewing the information, and please contact me if you have any questions regarding the above and attached information.

We look forward to presenting the project to the Commission on 17 Nov 2021.

Sincerely,



Steve Ivas, MS, PWS, Principal

XC: A. Patel, Hudson 62 Realty, c/o Jamsan Hotel Management, 83 Hartwell Ave, Lexington MA 02421
T. Power, PVI Site Design, LLC, 18 Glendale Rd., Norwood MA 02062
(Both via email)

Encl:

Section C.3 of the WPA Form 3 - Notice of Intent
Climate Resiliency Checklist for Boston Hotel, 155 Porter Street
Building Sections, 175 Orleans St., Boston MA A300, A301, and A302, 12 Oct 202, T. Manning, RA
Utilities and Grading Plan, 11 09 2021, T. Power, P.E., PVI Site Design
Climate Change Narrative and Flood Design Affidavit, T. Manning, R.A., Russell & Dawson Inc., 09 Nov 2021



Massachusetts Department of Environmental Protection
Bureau of Resource Protection - Wetlands

WPA Form 3 – Notice of Intent

Massachusetts Wetlands Protection Act M.G.L. c. 131, §40

Provided by MassDEP:

MassDEP File Number

Document Transaction Number

EAST BOSTON

City/Town

C. Other Applicable Standards and Requirements (cont'd)

- (c) MESA filing fee (fee information available at <https://www.mass.gov/how-to/how-to-file-for-a-mesa-project-review>).

Make check payable to "Commonwealth of Massachusetts - NHESP" and **mail to NHESP** at above address

Projects altering 10 or more acres of land, also submit:

- (d) Vegetation cover type map of site

- (e) Project plans showing Priority & Estimated Habitat boundaries

- (f) OR Check One of the Following

1. Project is exempt from MESA review.
Attach applicant letter indicating which MESA exemption applies. (See 321 CMR 10.14, <https://www.mass.gov/service-details/exemptions-from-review-for-projectsactivities-in-priority-habitat>; the NOI must still be sent to NHESP if the project is within estimated habitat pursuant to 310 CMR 10.37 and 10.59.)

2. Separate MESA review ongoing. _____ a. NHESP Tracking # _____ b. Date submitted to NHESP

3. Separate MESA review completed.
Include copy of NHESP "no Take" determination or valid Conservation & Management Permit with approved plan.

3. For coastal projects only, is any portion of the proposed project located below the mean high water line or in a fish run?

- a. Not applicable – project is in inland resource area only b. Yes No

If yes, include proof of mailing, hand delivery, or electronic delivery of NOI to either:

South Shore - Cohasset to Rhode Island border, and
the Cape & Islands:

North Shore - Hull to New Hampshire border:

Division of Marine Fisheries -
Southeast Marine Fisheries Station
Attn: Environmental Reviewer
836 South Rodney French Blvd.
New Bedford, MA 02744
Email: dmf.envreview-south@mass.gov

Division of Marine Fisheries -
North Shore Office
Attn: Environmental Reviewer
30 Emerson Avenue
Gloucester, MA 01930
Email: dmf.envreview-north@mass.gov

Also if yes, the project may require a Chapter 91 license. For coastal towns in the Northeast Region, please contact MassDEP's Boston Office. For coastal towns in the Southeast Region, please contact MassDEP's Southeast Regional Office.

- c. Is this an aquaculture project? d. Yes No

If yes, include a copy of the Division of Marine Fisheries Certification Letter (M.G.L. c. 130, § 57).

NOTE: Project filings should be prepared and submitted using the online [Climate Resiliency Checklist](#).

A.1 - Project Information

Project Name:	Boston Hotel		
Project Address:	155 Porter Street, Boston, MA 02128		
Project Address Additional:			
Filing Type (select)	Building Permit (prior to final design approval)		
Filing Contact	Utkarsh Patil	Russell and Dawson	utkarsh.patil@rdaep.com (860) 289-1100
Is MEPA approval required	No		3/14/2018

A.3 - Project Team

Owner / Developer:	Russell and Dawson
Architect:	Russell and Dawson
Engineer:	Russell and Dawson
Sustainability / LEED:	The Green Engineer, Inc.
Permitting:	Epsilon
Construction Management:	TBD

A.3 - Project Description and Design Conditions

List the principal Building Uses:	Hotel
List the First Floor Uses:	Front Desk, Dining, Amenity, BOH
List any Critical Site Infrastructure and or Building Uses:	

Site and Building:

Site Area:	50, 328 SF	Building Area:	64709 SF
Building Height:	71'-3"Ft	Building Height:	5 Stories
Existing Site Elevation - Low:	14.8 Ft BCB	Existing Site Elevation - High:	25.89 Ft BCB
Proposed Site Elevation - Low:	13.0 Ft BCB	Proposed Site Elevation - High:	25.89 Ft BCB
Proposed First Floor Elevation:	18.2 Ft BCB	Below grade levels:	1 stories

Article 37 Green Building:

LEED Version - Rating System :	LEED NC-v4	LEED Certification:	Yes
Proposed LEED rating:	Silver	Proposed LEED point score:	58 Pts.

Building Envelope

When reporting R values, differentiate between R discontinuous and R continuous. For example, use “R13” to show R13 discontinuous and use R10c.i. to show R10 continuous. When reporting U value, report total assembly U value including supports and structural elements.

Roof:	R-31.25	Exposed Floor:	Not insulated
Foundation Wall:	N/A	Slab Edge (at or below grade):	Not insulated

Vertical Above-grade Assemblies (%'s are of total vertical area and together should total 100%):

Area of Opaque Curtain Wall & Spandrel Assembly:	0(%)	Wall & Spandrel Assembly Value:	R-11.76
Area of Framed & Insulated / Standard Wall:	39.78 (%)	Wall Value	R-11.76
Area of Vision Window:	60(%)	Window Glazing Assembly Value:	U-0.3
		Window Glazing SHGC:	SHGC = 0.37
Area of Doors:	0.22%	Door Assembly Value:	0.3(U)

Energy Loads and Performance

For this filing – describe how energy loads & performance were determined

The performance and the overall energy use was estimated using eQUEST energy modeling tool based on the information provided by the design team.

Annual Electric:	727,966 kWh	Peak Electric:	748.8(kW)
Annual Heating:	1,083 MMbtu	Peak Heating:	1.73(MMbtu)
Annual Cooling:	193 MMbtu	Peak Cooling:	150(Tons)
Energy Use - Below ASHRAE 90.1 - 2013:	8.3 %	Have the local utilities reviewed the building energy performance?	Yes
Energy Use - Below Mass. Code:	8.3 %	Energy Use Intensity:	56.7 kBtu/SF

Back-up / Emergency Power System

Electrical Generation Output:	125 kW	Number of Power Units:	Two
System Type:	Emergency power application	Fuel Source:	Natural gas

Emergency and Critical System Loads (in the event of a service interruption)

Electric:	88.9(kW)	Heating:	0 MMbtu/hr
		Cooling:	0 Tons/hr

B – Greenhouse Gas Reduction and Net Zero / Net Positive Carbon Building Performance

Reducing GHG emissions is critical to avoiding more extreme climate change conditions. To achieve the City's goal of carbon neutrality by 2050 new buildings performance will need to progressively improve to net carbon zero and positive.

B.1 – GHG Emissions - Design Conditions

For this Filing - Annual Building GHG Emissions: 311(Tons)

For this filing - describe how building energy performance has been integrated into project planning, design, and engineering and any supporting analysis or modeling:

The project team used energy modeling during the design phases to identify appropriate energy efficiency targets

Describe building specific passive energy efficiency measures including orientation, massing, envelop, and systems:

The building has a high-performance glazing system

Describe building specific active energy efficiency measures including equipment, controls, fixtures, and systems:

The design includes high efficiency MEP systems and local controls, reduced LPD fixtures and a BAS for effective and efficient control of systems.

Describe building specific load reduction strategies including on-site renewable, clean, and energy storage systems:

The building uses high efficiency VRV hvac systems for heating and cooling, combined with LED fixtures for energy efficiency. The big windows in all rooms provides ample natural light and reduces lighting load.

Describe any area or district scale emission reduction strategies including renewable energy, central energy plants, distributed energy systems, and smart grid infrastructure:

Describe any energy efficiency assistance or support provided or to be provided to the project:

The project is pursuing incentives through the MassSave program

B.2 - GHG Reduction - Adaptation Strategies

Describe how the building and its systems will evolve to further reduce GHG emissions and achieve annual carbon net zero and net positive performance (e.g. added efficiency measures, renewable energy, energy storage, etc.) and the timeline for meeting that goal (by 2050):

In the future, when the base building systems components need to be replaced the new components will be state of the art (at the time) and in all likelihood more energy efficient than the initial systems.

C - Extreme Heat Events

Annual average temperature in Boston increased by about 2° F in the past hundred years and will continue to rise due to climate change. By the end of the century, the average annual temperature could be 56° (compared to 46° now) and the number of days above 90° (currently about 10 a year) could rise to 90.

C.1 – Extreme Heat - Design Conditions

Temperature Range - Low:	6 Deg.	Temperature Range - High:	91 Deg.
Annual Heating Degree Days:	5596	Annual Cooling Degree Days:	750

What Extreme Heat Event characteristics will be / have been used for project planning

Days - Above 90°:	14	Days - Above 100°:	0
Number of Heatwaves / Year:	3	Average Duration of Heatwave (Days):	0

Describe all building and site measures to reduce heat-island effect at the site and in the surrounding area:

We have maximized the green space on the site by introducing landscape and green roof on the building.

C.2 - Extreme Heat – Adaptation Strategies

Describe how the building and its systems will be adapted to efficiently manage future higher average temperatures, higher extreme temperatures, additional annual heatwaves, and longer heatwaves:

The building utilizes low-e window glazing, combined with low energy consumption hvac units.

Describe all mechanical and non-mechanical strategies that will support building functionality and use during extended interruptions of utility services and infrastructure including proposed and future adaptations:

To prepare for future power interruptions, future adaptations can be made to equip the building hvac with generator backup and install solar panels on the roof and as carports in the parking lot.

D - Extreme Precipitation Events

From 1958 to 2010, there was a 70 percent increase in the amount of precipitation that fell on the days with the heaviest precipitation. Currently, the 10-Year, 24-Hour Design Storm precipitation level is 5.25". There is a significant probability that this will increase to at least 6" by the end of the century. Additionally, fewer, larger storms are likely to be accompanied by more frequent droughts.

D.1 – Extreme Precipitation - Design Conditions

10 Year, 24 Hour Design Storm: 4.6 In.

Describe all building and site measures for reducing storm water run-off:

The site design reduces the overall impervious area of the site. A new stormwater infiltration system is proposed to infiltrate the first 1" of rainfall.

D.2 - Extreme Precipitation - Adaptation Strategies

Describe how site and building systems will be adapted to efficiently accommodate future more significant rain events (e.g. rainwater harvesting, on-site storm water retention, bio swales, green roofs):

The site utilizes on-site retention to reduce runoff from leaving the property.

E – Sea Level Rise and Storms

Under any plausible greenhouse gas emissions scenario, sea levels in Boston will continue to rise throughout the century. This will increase the number of buildings in Boston susceptible to coastal flooding and the likely frequency of flooding for those already in the floodplain.

Is any portion of the site in a FEMA SFHA?

Yes

What Zone:

AE

Current FEMA SFHA Zone Base Flood Elevation:

16.46 Ft BCB

Is any portion of the site in a BPDA Sea Level Rise - Flood Hazard Area? Use the online [BPDA SLR-FHA Mapping Tool](#) to assess the susceptibility of the project site.

Yes

If you answered YES to either of the above questions, please complete the following questions. Otherwise you have completed the questionnaire; thank you!

E.1 – Sea Level Rise and Storms – Design Conditions

Proposed projects should identify immediate and future adaptation strategies for managing the flooding scenario represented on the BPDA Sea Level Rise - Flood Hazard Area (SLR-FHA) map, which depicts a modeled 1% annual chance coastal flood event with 40 inches of sea level rise (SLR). Use the online [BPDA SLR-FHA Mapping Tool](#) to identify the highest Sea Level Rise - Base Flood Elevation for the site. The Sea Level Rise - Design Flood Elevation is determined by adding either 24” of freeboard for critical facilities and infrastructure and any ground floor residential units OR 12” of freeboard for other buildings and uses.

Sea Level Rise - Base Flood Elevation:

19.3 Ft BCB

Sea Level Rise - Design Flood Elevation:

20.3 Ft BCB

First Floor Elevation:

18.2 Ft BCB

Site Elevations at Building:

18.2 Ft BCB

Accessible Route Elevation:

18.2 Ft BCB

Describe site design strategies for adapting to sea level rise including building access during flood events, elevated site areas, hard and soft barriers, wave / velocity breaks, storm water systems, utility services, etc.:

One of the exit stairs currently discharges at 25.9 BCB. The other exit stair will have provisions to exit above sea level rise DFE.

Describe how the proposed Building Design Flood Elevation will be achieved including dry / wet flood proofing, critical systems protection, utility service protection, temporary flood barriers, waste and drain water back flow prevention, etc.:

The building gk]HW[YUfzHfUbgZcfa Yf UbX[YbYfUrcf k]`VY`d`UWX`cb U & (``\] \ ` d`Uhzfa `tc`a`YYhXZY`fYei`jFYa`Ybrg` Electrical panels from basement relocated.

Describe how occupants might shelter in place during a flooding event including any emergency power, water, and wastewater provisions and the expected availability of any such measures:

The building is equipped with backup generators and there is a possibility of having solar energy in the future that would support shelter taken by occupants during any emergency situations.

Describe any strategies that would support rapid recovery after a weather event:

The existing building is cast-in-place concrete which is inherently resistant to the weather adversities.

E.2 – Sea Level Rise and Storms – Adaptation Strategies

Describe future site design and or infrastructure adaptation strategies for responding to sea level rise including future elevating of site areas and access routes, barriers, wave / velocity breaks, storm water systems, utility services, etc.:

To cope with sea level rise, there is a future possibility of raising the first-floor level by 2'. The site design would follow along on the possibility of raising the site areas. The ample floor to floor height of the existing building would allow this change to be possible.

Describe future building adaptation strategies for raising the Sea Level Rise Design Flood Elevation and further protecting critical systems, including permanent and temporary measures:

high concrete platform and modify stair 2 for raising floor above future BFE.

A pdf and word version of the Climate Resiliency Checklist is provided for informational use and off-line preparation of a project submission. **NOTE: Project filings should be prepared and submitted using the online [Climate Resiliency Checklist](#).**

For questions or comments about this checklist or Climate Change best practices, please contact: John.Dalzell@boston.gov

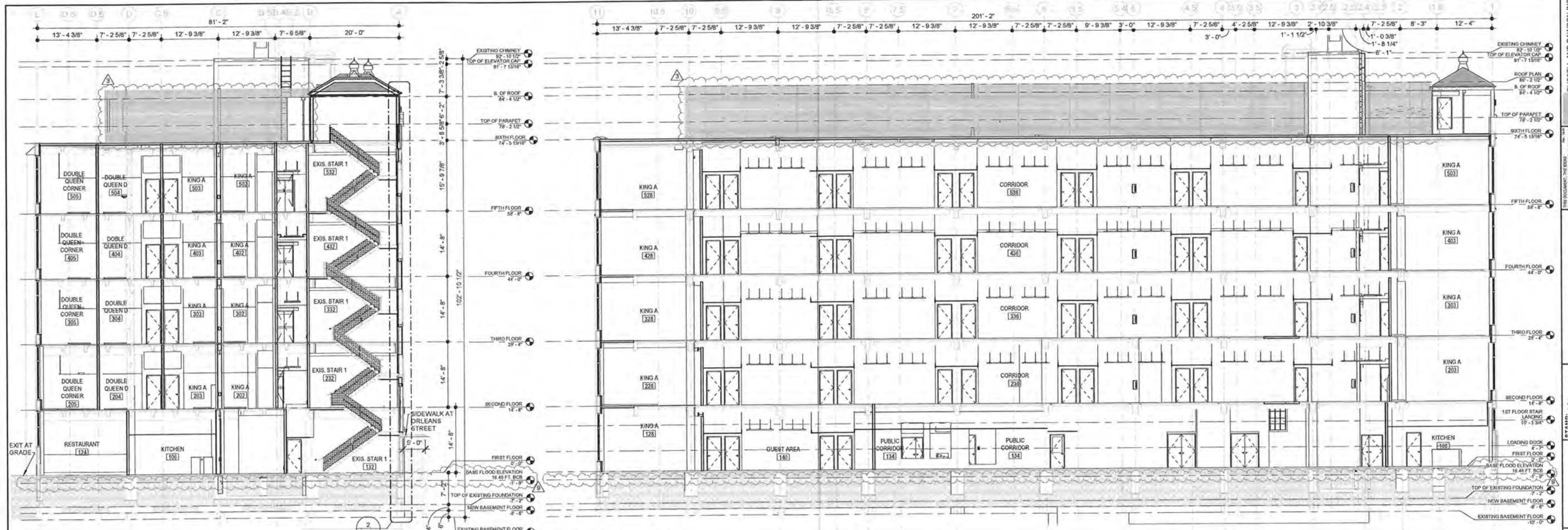

1 BUILDING SECTION-2
3/32" = 1'-0"

3 BUILDING SECTION -1
3/32" = 1'-0"

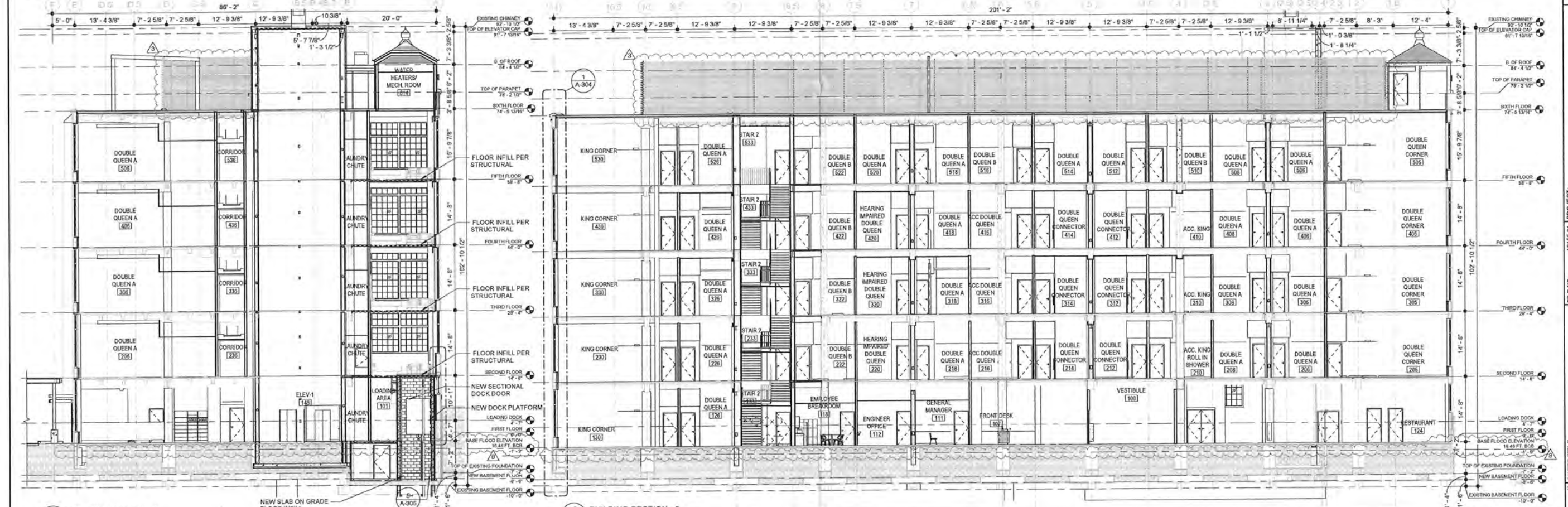

2 BUILDING SECTION -4
3/32" = 1'-0"

4 BUILDING SECTION -3
3/32" = 1'-0"

RUSSELL AND DAWSON INC.
ARCHITECTURE & ENGINEERING
175 ORLEANS STREET, BOSTON, MA 02128
TEL: (617) 264-1000 FAX: (617) 264-1001

REVISIONS

NO.	DESCRIPTION	DATE
1	GENERAL REVISION	11/27/2015
2	GENERAL REVISION	12/22/2015
3	GENERAL REVISION	1/27/2016
4	GENERAL REVISION	1/27/2016

PROJECT: CONVERSION TO CAMBRIA SUITES
175 ORLEANS STREET, BOSTON, MA 02128

SHEET TITLE: BUILDING SECTIONS
SHEET NUMBER: A-300

FILE NO.: 19155.01
SCALE: 3/32" = 1'-0"
DATE: 09/26/2016
DRAWN BY: AJP
CHECKED BY: UNP

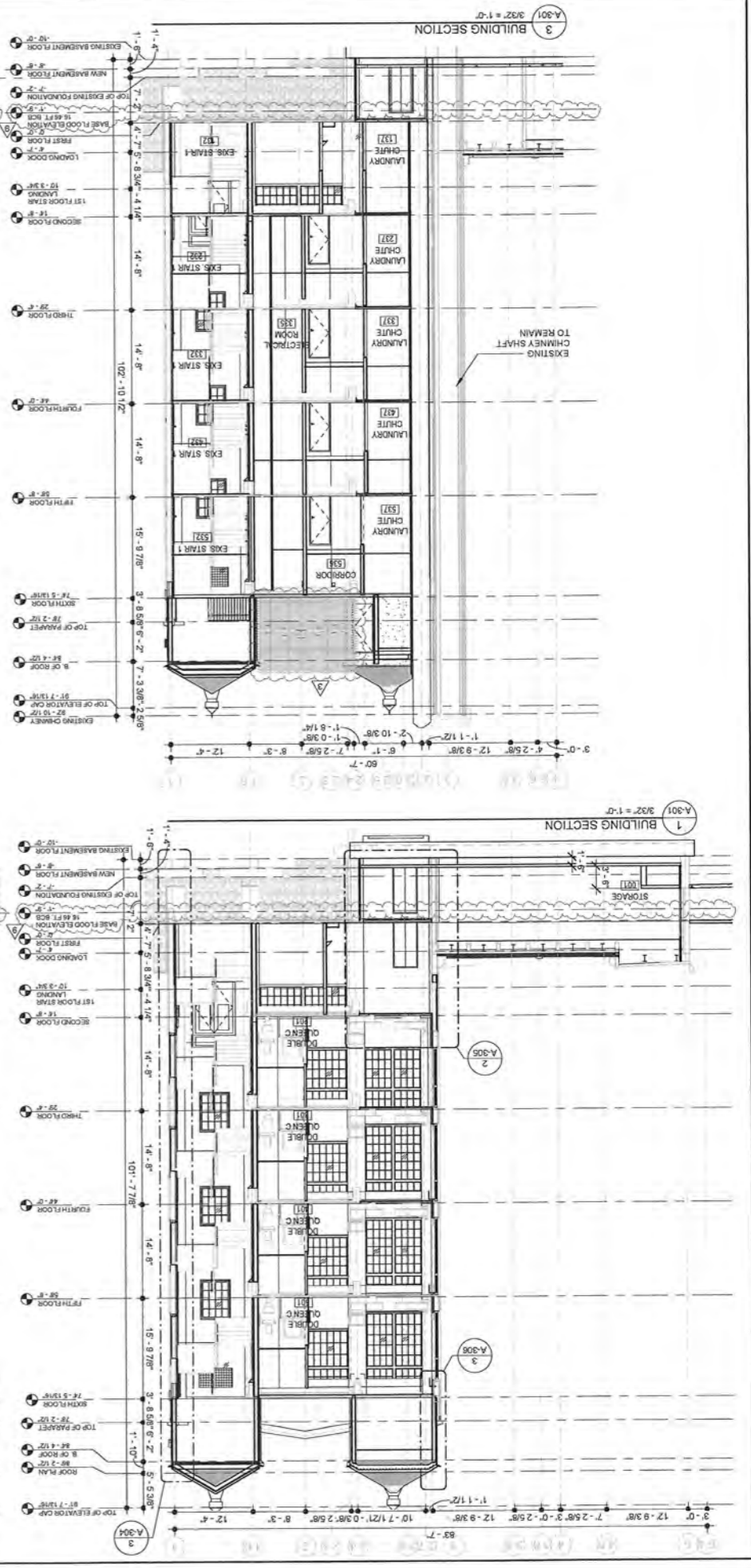

A-301 SHEET NUMBER

BUILDING SECTIONS

CONVERSION TO CAMBRIA SUITES

FILE NO: 19155.01
 SCALE: 3/32" = 1'-0"
 DATE: 08/29/2018
 DRAWN BY: AJP
 CHECKED BY: UJP

PROJECT: 175 ORLEANS STREET, BOSTON, MA 02128

NO.	DESCRIPTION	DATE	BY
1	GENERAL REVISION	11/22/2018	UJP
2	GENERAL REVISION	11/22/2018	UJP
3	GENERAL REVISION	10/27/2021	UJP

RUSSELL AND DAWSON INC.
 ARCHITECTURE & ENGINEERING

175 ORLEANS STREET, BOSTON, MA 02128
 TEL: (617) 252-1100 FAX: (617) 252-1101
 WWW.RUSSELLANDDAWSON.COM



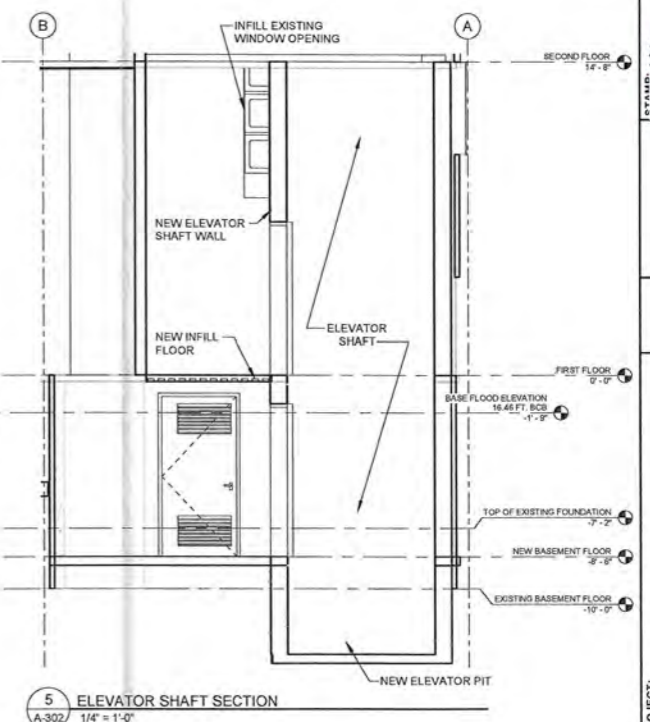
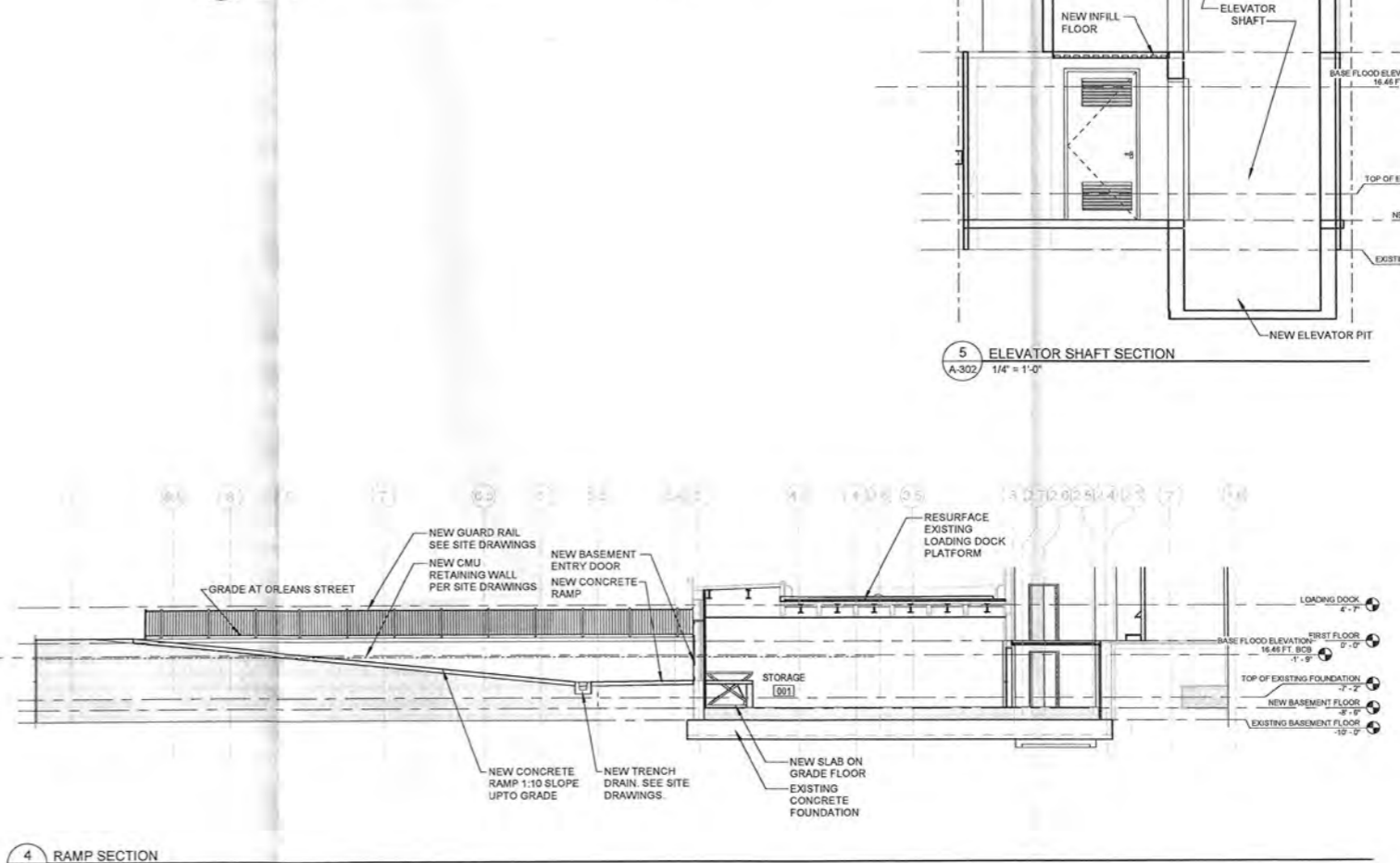
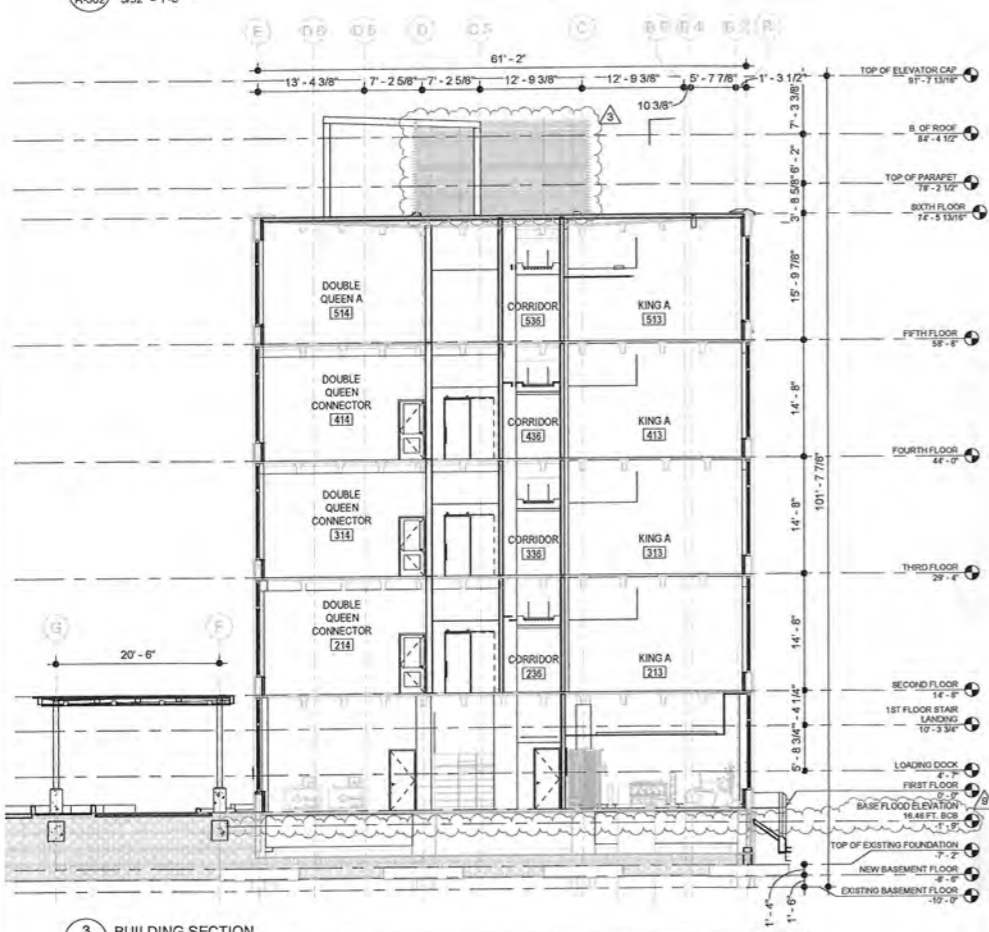
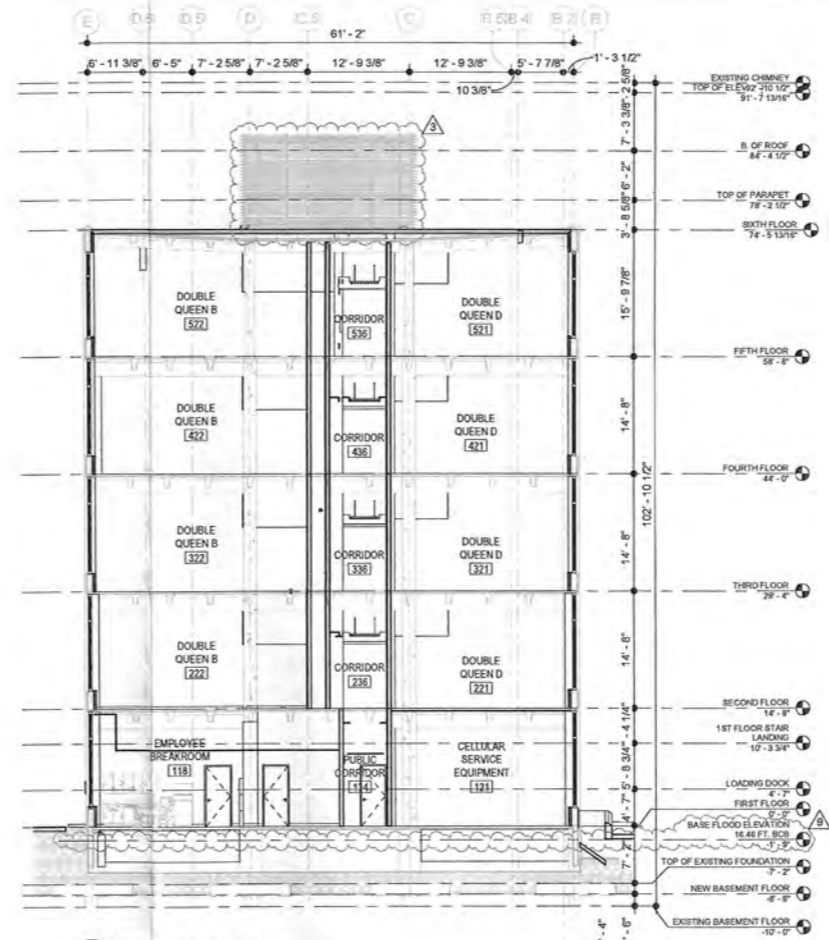
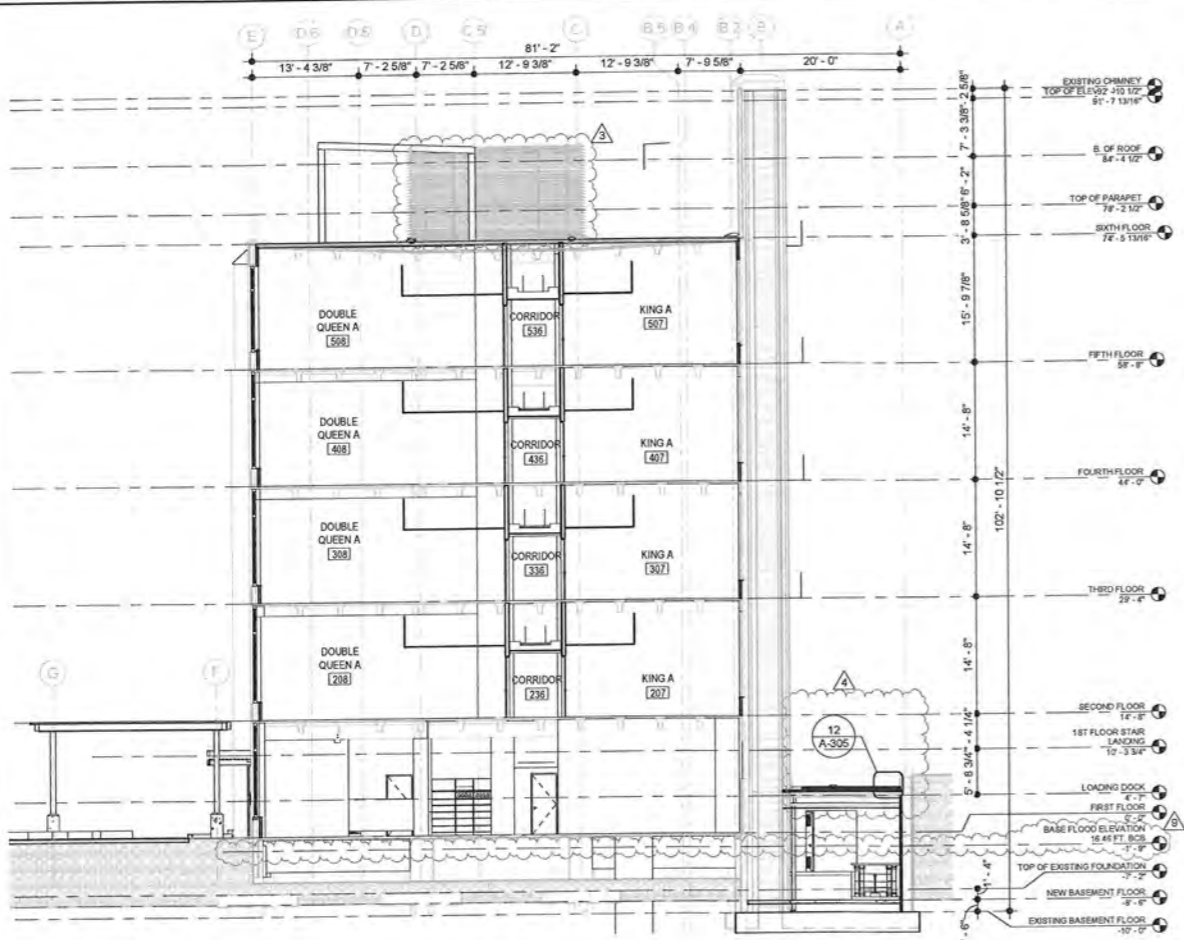

RUSSELL AND DAWSON INC. ARCHITECTURE & ENGINEERING 1111 MASSACHUSETTS STREET, SUITE 100 BOSTON, MA 02128 TEL: (617) 261-1100 FAX: (617) 261-1101	
PROJECT: CONVERSION TO CAMBRIA SUITES 175 ORLEANS STREET, BOSTON, MA 02128	
FILE NO: 16155.01 SCALE: As Indicated DATE: 08/29/2018 DRAWN BY: ANP CHECKED BY: UWP	SHEET TITLE: BUILDING SECTIONS SHEET NUMBER: A-302
REVISIONS	
NO.	DESCRIPTION
1	GENERAL REVISION
2	GENERAL REVISION
3	GENERAL REVISION
4	GENERAL REVISION
5	GENERAL REVISION
6	GENERAL REVISION
7	GENERAL REVISION
8	GENERAL REVISION
9	GENERAL REVISION

SEWER FLOW CALCULATIONS:

SEWER DESIGN FLOWS BASED ON 310 CMR 15

EXISTING USE:	INDUSTRIAL BUILDING (540 PEOPLE)
UNIT FLOW:	15 GPD / PERSON
EXISTING FLOW:	8,100 GPD
PROPOSED USE:	123 ROOM HOTEL + 130 SEAT RESTAURANT
UNIT FLOW:	110 GPD PER ROOM 35 GPD PER SEAT
HOTEL FLOW:	13,530 GPD
RESTAURANT FLOW:	4,550 GPD
TOTAL NEW FLOW:	18,080 GPD
NET CHANGE:	+9,980 GPD (SEWER FLOW INCREASE)
GREASE TRAP SIZING:	15 GAL PER SEAT
UNIT FLOW:	1,950 GAL. → 2,000 GAL TRAP PROPOSED.
MIN. SIZE:	

DRAINAGE CALCULATIONS SUMMARY

(FULL DRAINAGE CALCULATIONS WERE PREPARED USING HYDROCAD V10)

1" STORM EVALUATION	
TOTAL IMPERVIOUS AREA:	41,835 SF
1" STORM VOLUME:	3,486 CF
RECHARGE VOLUME:	
CHAMBERS:	
VOL. / CHAMBER AT 27" FULL:	45.4 CUFT (PER STORMTECH)
64 CHAMBERS:	45.4 X 64 = 2,906 CUFT
STONE:	
DIMENSIONS: 60.58' X 39.5' X 33" =	6,580 CUFT
LESS CHAMBERS: 6,580 - 2,906 =	3,674 CUFT
30% VOIDS: 3,674 X 0.3 =	1,102 CUFT
TOTAL:	2,906 + 1,102 = 4,008 CUFT

4,008 > 3,486 = OK

INSPECTION SIGN-OFF SCHEDULE

ITEM NO.	DESCRIPTION OF SERVICE	QTY.	BWSC INSPECTOR DATE	COMMENTS
1	SANITARY PIPE INSTALLATION	68'		
2	SANITARY MANHOLE INSTALLATION	1		
3	SANITARY CHIMNEY CONNECTION	1		
4	REMOVE SEWER SERVICE	1		
5	GREASE TRAP INSTALLATION	1		
6	VIDEO NEW SANITARY PIPES	1		
7	OUTLET CONTROL STRUCTURE (OCS)	1		
8	DRAINAGE PIPE INSTALLATION	320'		
9	DYE TEST SEWER	1		
10	DRAINAGE CHIMNEY CONNECTION	1		
11	DON'T DUMP PLAQUE INSTALLATION	6		
12	VIDEO NEW DRAIN PIPES	1		
13	UNDERGROUND RECHARGE SYSTEM	1		
14	DYE TEST NEW DRAINAGE SYSTEM	1		
15	FIELD CONNECTION AT MAIN	1		
16	6" FIRE SERVICE INSTALLATION	1		
17	4" DOMESTIC SERVICE INSTALLATION	1		
18	BACKFLOW CONNECTION	1		
19	NEW 2" METER INSTALLATION	1		
20	TRENCH DRAIN	1		
21	DRAIN MANHOLE 1	1		
22	DRAIN MANHOLE 2	1		
23	DRAIN MANHOLE 3	1		
24	DRAIN MANHOLE 4	1		
25	DRAIN MANHOLE 5 (DIVERSION MANHOLE)	1		
26	DRAIN MANHOLE 6 (SUMP AND HOOD)	1		
27	REMOVE 4" FIRE SERVICE	1		
28	REMOVE 4" FIRE SERVICE	1		
29	REMOVE 4" FIRE SERVICE	1		
30	SHALLOW CATCH BASIN PCB1	1		
31	SHALLOW CATCH BASIN PCB2	1		
32	SHALLOW CATCH BASIN PCB3	1		
33	TYP CATCH BASIN WITH OIL TRAP PCB4	1		
34	TYP CATCH BASIN WITH OIL TRAP PCB5	1		

GRADING AND UTILITY NOTES:

- EXISTING CONDITIONS INFORMATION IS REPRODUCED FROM THE "SITE PLAN" PREPARED BY ANDERSON SURVEYS, INC. DATED APRIL 2, 2017.
- ALL ELEVATIONS REFER TO BOSTON CITY BASE.
- WHERE PROPOSED GRADES MEET EXISTING GRADES, CONTRACTOR SHALL BLEND GRADES TO PROVIDE A SMOOTH TRANSITION BETWEEN EXISTING AND NEW WORK. PONDING AT TRANSITION AREAS WILL NOT BE ALLOWED.
- ENSURE ALL EXISTING (TO REMAIN) AND PROPOSED MANHOLE COVERS PROPERLY IDENTIFY UTILITY SERVICED.
- CONTRACTOR SHALL VERIFY EXISTING GRADES AND NOTIFY OWNER'S REPRESENTATIVE OF ANY DISCREPANCIES.
- CONTRACTOR SHALL ADJUST ALL UTILITY ELEMENTS MEANT TO BE FLUSH WITH GRADE (CLEAN-OUTS, UTILITY MANHOLES, ETC) THAT IS AFFECTED BY SITE WORK OR GRADE CHANGES, WHETHER SPECIFICALLY NOTED ON PLANS OR NOT.
- ALL CONSTRUCTION TO BE DONE IN ACCORDANCE WITH BOSTON WATER AND SEWER STANDARDS.
- WHERE EXISTING UTILITY IS FOUND TO CONFLICT WITH THE PROPOSED WORK, THE LOCATION ELEVATION, AND SIZE OF THE UTILITY SHALL BE ACCURATELY DETERMINED WITHOUT DELAY BY THE CONTRACTOR AND THE INFORMATION FURNISHED TO THE ENGINEER FOR RESOLUTION OF THE CONFLICT.
- THE CONTRACTOR SHALL ALTER THE MASONRY OF THE TOP SECTIONS OF ALL EXISTING DRAINAGE STRUCTURES AS NECESSARY FOR CHANGES IN GRADE, AND RESET ALL FRAMES, GRATES, AND BOXES TO THE PROPOSED FINISHED GRADE.
- PROTECT AND MAINTAIN EXISTING ON-SITE DRAINAGE STRUCTURES AND PIPES UNLESS OTHERWISE NOTED.
- DRAINAGE PIPES SHALL BE SDR 35 UNLESS OTHERWISE NOTED.
- ALL SEWER PIPES SHALL BE SDR 35 UNLESS OTHERWISE NOTED.
- ALL WATER PIPES 4" OR LARGER SHALL BE CLASS 56, ZINC COATED DUCTILE IRON.
- ALL SOILS REMOVED FROM THE SITE SHALL BE DISPOSED OF BY THE CONTRACTOR AT CONTRACTOR'S EXPENSE. SOILS MAY BE CONTAMINATED. CONTRACTOR SHALL CONSULT WITH OWNER'S LICENSED SITE PROFESSIONAL (LSP) PRIOR TO ANY EXCAVATION TO CONFIRM EXCAVATION AND DISPOSAL REQUIREMENTS.
- FEMA FLOOD ZONES HAVE BEEN DIGITIZED BASED ON THE FEMA MAPS DATED 3-16-2016.

TV INSPECTION OF SEWERS & DRAINS

- THE CONTRACTOR SHALL FURNISH ALL EQUIPMENT, LABOR, MATERIALS, AND SUPERVISION AS REQUIRED TO INSPECT THE INTERIOR OF ALL SEWERS AND DRAINS, PROVIDE VIDEO RECORDINGS WITH VOICE DESCRIPTIONS AS WELL AS FULL INSPECTION REPORTS, AND ALL OTHER APPURTENANT WORK, WITHIN THE LIMITS SHOWN ON THE DRAWINGS, AS DIRECTED BY THE ENGINEER, AND AS SPECIFIED IN THE BOSTON WATER & SEWER (BWSC) SPECIFICATION "TELEVISION INSPECTION OF SEWERS AND DRAINS" AS LATEST REVISED AVAILABLE AT: [HTTP://WWW.BWSC.ORG/REGULATIONS/CONSTRUCTION_SPECS/CONSTRUCTION_SPECS](http://www.bwsc.org/regulations/construction_specs/construction_specs)
- PIPES SHALL NOT BE INSPECTED UNTIL COMPLETELY CLEANED IN ACCORDANCE WITH THE SPECIFICATION NOTED IN #1 AND TO THE SATISFACTION OF THE BWSC INSPECTOR AND OWNER'S REPRESENTATIVE.

FOR BWSC USE ONLY
 PARCEL #: 0103926000
 PARCEL #: 0103927000
 PARCEL #: 0103928000

HOTEL REDEVELOPMENT
 155 PORTER STREET, EAST BOSTON, MA
 CLIENT/APPLICANT:
HUDSON 62 REALTY LLC
 440 BEDFORD ST, LEXINGTON, MA 01824

REV: 6/09/17-2019 BPD COMMENTS
 7/11/20/2019 BPD COMMENTS
 8/01/20/2020 BPD COMMENTS
 9/11/20/2020 BPD COMMENTS
 10/29/2021 NO COMMENTS
 11/02/2021 FEMA/LSCS LINE
 12/11/2021 CC AGENT COMMENTS

ISSUED FOR CONSTRUCTION
 DECEMBER 8, 2017
GRADING AND UTILITY PLAN
 BWSC SITE PLAN #17410
 SCALE: 1"=20'
 JOB NO: 003-003
 FILE: 003-003-G.dwg
 DRAWN: TJP
 CHECKED: TJP
 SHEET NO: C102

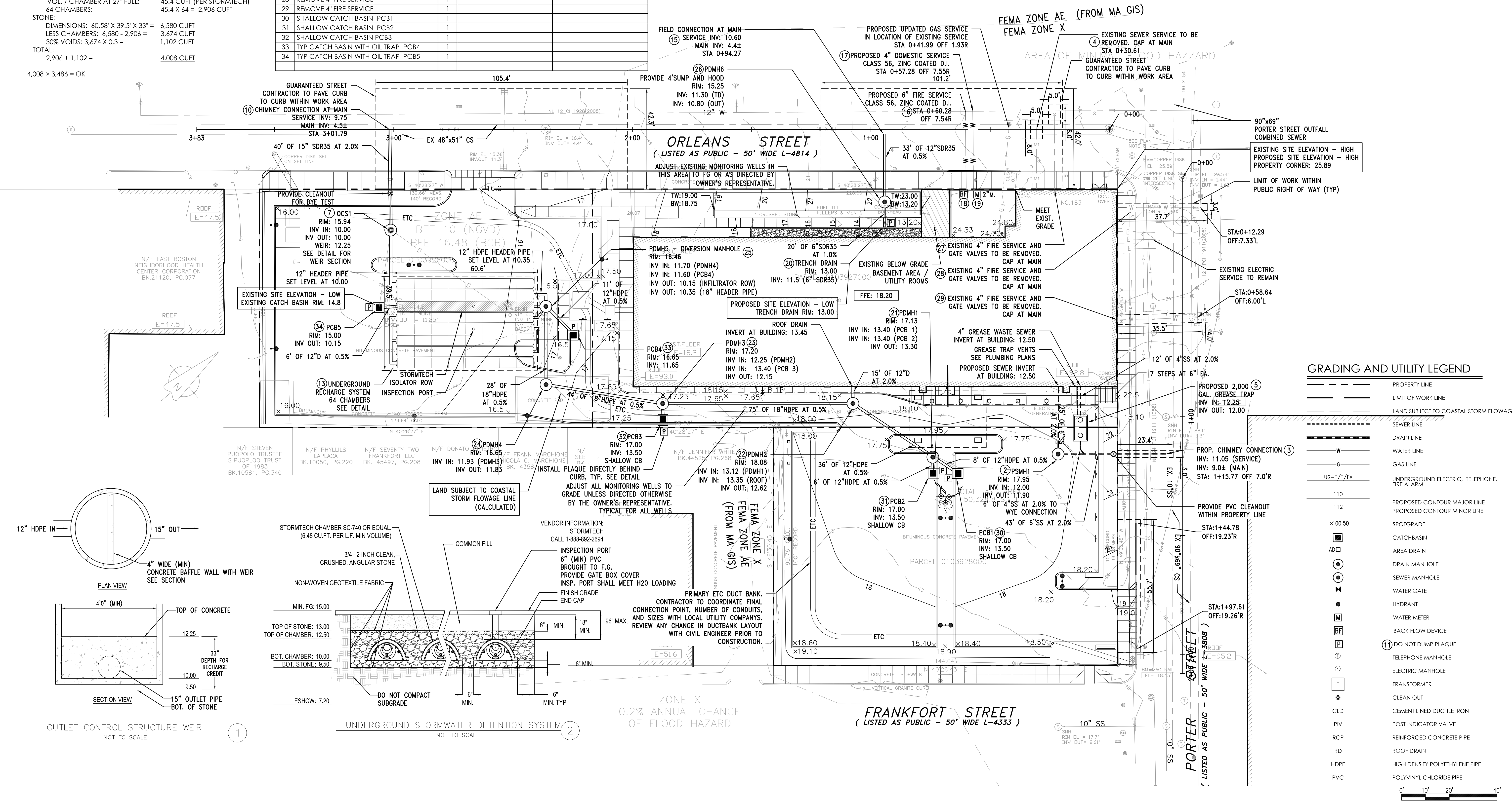

GRADING AND UTILITY LEGEND

---	PROPERTY LINE
---	LIMIT OF WORK LINE
---	LAND SUBJECT TO COASTAL STORM FLOWAGE
---	SEWER LINE
---	DRAIN LINE
---	WATER LINE
---	GAS LINE
---	UG-E/T/FA
---	UNDERGROUND ELECTRIC, TELEPHONE, FIRE ALARM
---	110
---	112
---	PROPOSED CONTOUR MAJOR LINE
---	PROPOSED CONTOUR MINOR LINE
---	SPOTGRADE
---	CATCHBASIN
---	AREA DRAIN
---	DRAIN MANHOLE
---	SEWER MANHOLE
---	WATER GATE
---	HYDRANT
---	WATER METER
---	BACK FLOW DEVICE
---	11) DO NOT DUMP PLAQUE
---	TELEPHONE MANHOLE
---	ELECTRIC MANHOLE
---	TRANSFORMER
---	CLEAN OUT
---	CLDI
---	PV
---	RCP
---	RD
---	HDPE
---	PVC
---	POLYVINYL CHLORIDE PIPE

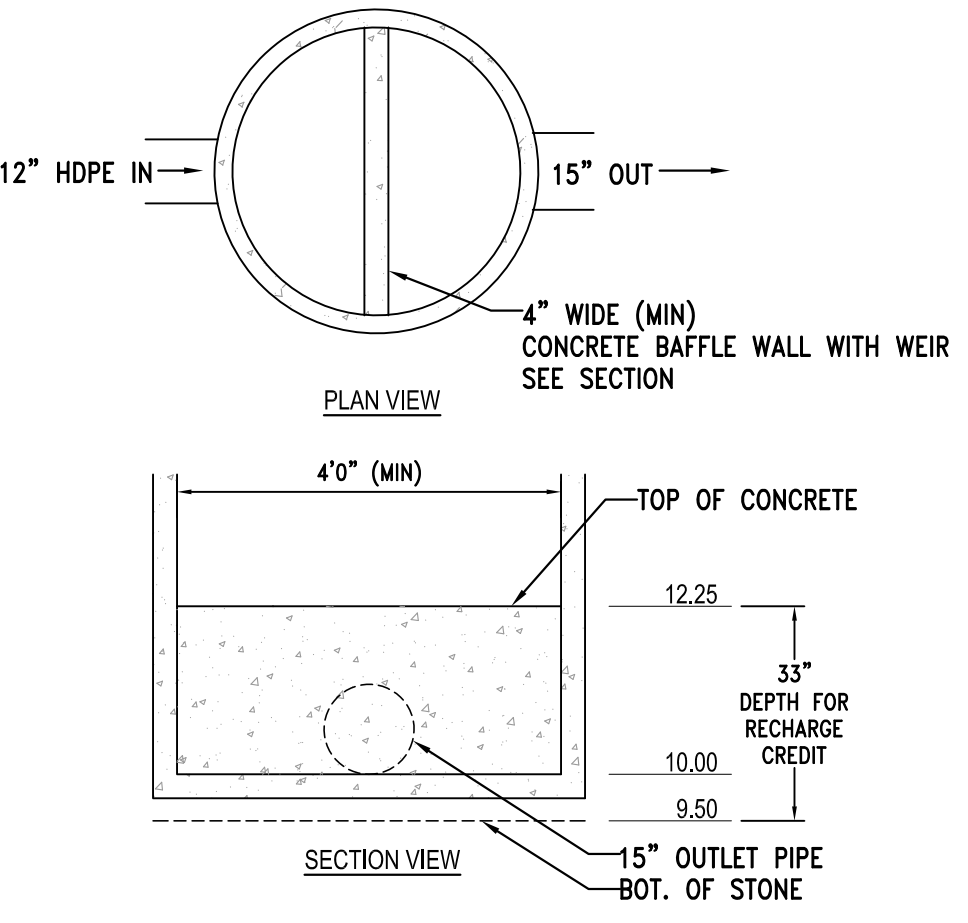

OUTLET CONTROL STRUCTURE WEIR NOT TO SCALE

UNDERGROUND STORMWATER DETENTION SYSTEM NOT TO SCALE



Climate Change Narrative and Flood Design Affidavit

June 29, 2021

August 9, 2021 (Revised)

November 9, 2021 (Revised)

Hotel Redevelopment

175 Orleans Street

East Boston, Massachusetts

File No. 16155.01

In construction, the best thing one can do for the environment is reuse an existing building. Russell and Dawson is proposing, on behalf of our client Hudson 62 Realty LLC, to make adaptive reuse of an existing 5-story factory building as a 123-room hotel with loft style guest suites. The original floor area and building envelope will remain with cosmetic repairs to the façade and new, more energy-efficient windows that recreate the historic appearance. In order to comply with Conservation Commission guidelines, we have proposed several measures to minimize the effect of climate change on this proposed development.

Due to the increase of greenhouse gases resulting from human activity in the atmosphere, the northeast climate in five years or ten years will change from what we experience next year. Climate change can be expected to have a number of effects that may impact this property, including a lack of rain or an excess of rain, a general increase or decrease in temperature, greater extremes of temperature both hot and cold, greater frequency and intensity of hurricanes and other storms, exposure to additional pandemic diseases, and sea level rise.

Climate Equity and Environmental Justice

This project will be air conditioned. In a city, anyone able to afford air conditioning dumps their excess heat on those who cannot afford it. This changes the microclimate and may result in some minor additional discomfort, but in a prolonged heat wave it might have more adverse effects. The only way we can think of to avoid this issue is to dump the heat to groundwater with a geothermal heat pump, but that does not appear to be practical on this site. Per HomeArea.com, of the 14 cities in Massachusetts Boston has the most income inequality and it is increasing. Changes to the system of income maintenance subsidies and taxation that would reduce this inequality to the point that the difference in effects of environmental degradation on the poor and the rich would be de minimis is beyond the scope of this project.

The urban heat island effect can be mitigated by selection of exterior horizontal and vertical surfaces. This building has been detailed with an EPDM roof. A white roof is preferred as sunlight is reflected rather than being turned into heat but omitting the carbon black from EPDM makes it brittle and it deteriorates more quickly. The product specified is approved for use in a High Velocity Hurricane Zone such as this one. The approval lists a bi-laminate membrane with black on the bottom and white on top. This will be selected in shop drawing approval. Trellis products appropriate for a building of this height exist that support the growth of vines. However, this is a registered historic building that would not meet the criteria of the Secretary of the Interior if such a change was made.



The large areas of glazing shown reproduce historic conditions with a more energy-efficient envelope that includes low-e glass to reduce cooling demand and heat expulsion. All of the surface area not required for parking or sidewalks has been intensively planted with groundcover, perennials, ornamental grasses, shrubs, and trees. This represents a substantial increase in pervious area compared to the existing conditions. Almost all species selected are drought tolerant per local nursery catalogs and extension services. Final selection of species will occur at purchase depending on availability. An additional criterion used in selection will be resistance to inundation by salt water. Cement concrete as used in the sidewalks is generally more reflective than bituminous concrete used in the parking areas, which receive light and radiate heat. The use of bituminous concrete has already been approved as being in conformance with Boston engineering standards. We have used concrete pavers on other projects. Coordination between public agencies in achieving climate goals, along with a review earlier in the process would be helpful. We understand that some of these issues have come to the fore during project design and approval.

Discussion of Climate Resiliency Measures

In response to considerations of resilience we are making the following changes now that would maximize current resilience and minimize the future cost of raising the first floor: revising the section of the exit stair that discharges to the lower grade so that egress may continue to pass below the landing, raise the exterior generator and transformer platforms 24", raise the housekeeping pad of the interior electrical switchgear 24", and move the cellular equipment presently planned for the basement to a higher floor. Although there will be considerable expense in raising the first-floor level if it came to that, it is possible to just extend the sanitary connections, while electrical service cables must be continuous and would have to be replaced.

Excess stormwater is sent to the public storm sewers, but only after treatment in a new underground recharge system that can process 30,000 gallons, well in excess of that received on site in a 1" storm.

The spread of infectious disease is even more variable than the potential for flooding. Fresh air will be provided by a central system, but heating and cooling are handled room by room, so spread of disease via the HVAC system is unlikely. Interior finishes are readily cleanable. We are not proposing shields at service areas as these have proved easy to install should they be required.

The exterior envelope and HVAC system have been designed to comply with current requirements for heating and cooling. They will be able to handle occasional extremes outside the design temperatures. Should the mean temperature increase substantially, it might be necessary to introduce additional cooling capacity, but there is no reason to increase it now. The exterior envelope has been designed to comply with current requirements for insulation and for wind loading. We find no estimates of a potential for increased wind loading. Insulation performance will be augmented by changes to the HVAC system should that be needed as discussed above.

Although New England is currently in a drought, previous droughts such as that from 1962 to 1966 have been more serious and were survived without recourse to measures such as rainwater collection in a cistern. We can use a lot less water than we do, and the inhabitants of New England have demonstrated their attention to and compliance with rules such as those that might be promulgated for usage reduction should that become necessary. Also, technology that reduces water usage has become widespread since 1966 and is incorporated in this building.



We hope this information is helpful.

Very truly yours,

RUSSELL AND DAWSON INC.

Thomas A. Manning, VP - Architectural

Duly Authorized





**Ivas Environmental
Environmental Sciences
Wetlands and Planning Services**

**315 Winter Street
Norwell MA 02061-1401
781.659.1690, spivas@comcast.net**

**City of Boston Conservation Commission
Boston City Hall
1 City Hall Square
Boston MA 02201**

25 Oct 21

RE: MA DEP File #: NE - 006-1816, 155 Porter Street, East Boston

Dear Mr./Ms. Chairperson and members of the Commission:

This letter covers the attached package of information provided to the City of Boston Conservation Commission. It is written as a response to Ms. K. Oetheimer's comments on the file review of the Notice of Intent and package of information provided before the 04 Aug 21 Public Hearings of 21 July 2021. It was recorded at DEP/NERO as filed on 12 Aug 21. A response was not available until now.

It also addresses the MA DEP NERO's comment, "Applicant must demonstrate that filling of LSCSF will not cause increased flooding on adjacent properties or public ways."

Documents that illustrate the comments responses are attached. They are included in the digital file and hard copies are attached to this cover letter.

The points made by Ms. Oetheimer and responses follow.

1. Section C.3 of the WPA 3 Form is not filled out.

Section C. 3 of the WPA Form has been filled out. The WPA form as revised is attached. Also attached is the USPS Certified Mail Receipt dated 16 Sep 21 for the mailed NOI copy to the Division of Marine Fisheries that is required by this section of the NOI with a "coastal project."

2. Please provide the certification of translation and affidavit of service for the abutter notifications.

The certification of translation and affidavit of service for the abutter notifications is attached. A copy of the Spanish language abutter notification with the subject details in Spanish is also attached.

Please note that the entire 320-letter mailing for the abutters' notification that included the notification entirely in Spanish was repeated for this project. A copy of the 40-page certificates of mailing (dated 02 Aug 21) is also attached.

3. On the Boston NOI form, you indicated you will be performing work in the Coastal Flood Resilience Zone. The Commission has not yet adopted regulations or delineations for this resource area, and as such this section should be left blank.

The section has been left blank.

4. Also on the Boston NOI form, BWSC approval is not listed in Section C.1, despite indicating in C.5 that the project is subject to BWSC review.

The two BWSC approvals with dates (Cross-connection and an overall approval, as shown on the plan set) have been added to Section C.1

5. The elevations shown on the plans do not match the elevations detailed on the BPDA Climate Resiliency Checklist. **Please review the updated Climate Resiliency Checklist and the updated plans that are provided as attachments here. The elevations are said to match.**
6. The Climate Resiliency Checklist also indicates there will be 6 stories below grade. Did you mean 1 story below grade for a total of 6 above and below?

Yes, there is a total of five stories above and one below grade. This has been changed in the Climate Resiliency Checklist in Section A.3.

7. Please include the LSCSF resource area on the plans.

The LSCSF resource has been included on the plans attached.

8. Please also include the base flood elevation line on the building section plans.

The base flood elevation has been provided on the building section plans attached.

9. While we appreciate the honesty in the discussion of the project's limited ability to address systemic issues related to climate change, the Commission would also like to see a more detailed discussion of how the project is planning for climate change in terms of dealing with flooding, increased precipitation, urban heat island impact, etc.

This section as been updated by the architects, Russell and Dawson. It is attached.

10. The comment from the MA DEP Northeast Region is: "Applicant must demonstrate that filling of LSCSF will not cause increased flooding on adjacent properties or public ways."

A letter from PVI Site Design, LLC dated 22 Oct 21 is attached that answers this question.

We posit that the above and attached information fully answers the City of Boston Conservation Commission's questions regarding this redevelopment project. Thank you for reviewing the information, and please contact me if you have any questions regarding the above and attached information.

Sincerely,

XC: A. Patel, Hudson 62 Realty, c/o Jamsan Hotel Management, 83 Hartwell Ave, Lexington MA 02421
 T. Power, PVI Site Design, LLC, 18 Glendale Rd., Norwood MA 02062
 (Both via email)

Encl: The enclosures that match specific questions are listed according to question:

Question Number	Enclosure																												
1.	Section C.3 of the WPA Form 3 - Notice of Intent Green Card Returned from DMF North Shore Office																												
2.	Translation Certification Spanish Language Abutter Notification Copies of Certificates of Mailing, for Second Mailing (02 Aug 21) Affidavit of Service for Second Mailing (02 Aug 21)																												
3.	Boston NOI Application Form - Page 3 - Coastal Flood Zone, at the top of the page, has been left blank.																												
4.	Boston NOI Application Form - Page 3 - the same page as #3, above: BWSC date of approval has been included (09 Apr 2018), at the bottom of the page.																												
5.	The Climate Resiliency Checklist has been revised. The Civil Plans have been revised:																												
	<table border="0" style="margin-left: 40px;"> <thead> <tr> <th style="text-align: left;">No.</th> <th style="text-align: left;">Title</th> <th style="text-align: left;">Plan By</th> <th style="text-align: left;">Date</th> </tr> </thead> <tbody> <tr> <td>No Number</td> <td>Site Plan</td> <td>Anderson Surveys, Inc</td> <td>27 Sep 21</td> </tr> <tr> <td>PL100</td> <td>Parcel Plan</td> <td>PVI Site Design</td> <td>20 Oct 21</td> </tr> <tr> <td>C100</td> <td>Site Prep Plan</td> <td>PVI Site Design</td> <td>20 Oct 21</td> </tr> <tr> <td>C101</td> <td>Layout & Mtls.</td> <td>PVI Site Design</td> <td>20 Oct 21</td> </tr> <tr> <td>C102</td> <td>Grading & Util.</td> <td>PVI Site Design</td> <td>20 Oct 21</td> </tr> <tr> <td>L101</td> <td>Landscape Plan</td> <td>RBLA Design</td> <td>20 Oct 21</td> </tr> </tbody> </table>	No.	Title	Plan By	Date	No Number	Site Plan	Anderson Surveys, Inc	27 Sep 21	PL100	Parcel Plan	PVI Site Design	20 Oct 21	C100	Site Prep Plan	PVI Site Design	20 Oct 21	C101	Layout & Mtls.	PVI Site Design	20 Oct 21	C102	Grading & Util.	PVI Site Design	20 Oct 21	L101	Landscape Plan	RBLA Design	20 Oct 21
No.	Title	Plan By	Date																										
No Number	Site Plan	Anderson Surveys, Inc	27 Sep 21																										
PL100	Parcel Plan	PVI Site Design	20 Oct 21																										
C100	Site Prep Plan	PVI Site Design	20 Oct 21																										
C101	Layout & Mtls.	PVI Site Design	20 Oct 21																										
C102	Grading & Util.	PVI Site Design	20 Oct 21																										
L101	Landscape Plan	RBLA Design	20 Oct 21																										
6.	Please refer to Climate Resiliency Checklist, in #5, above.																												
7.	Please refer to the plans in # 5, above.																												
8.	The Building Section Plans have been revised:																												
	<table border="0" style="margin-left: 40px;"> <thead> <tr> <th style="text-align: left;">No.</th> <th style="text-align: left;">Title</th> <th style="text-align: left;">Plan By</th> <th style="text-align: left;">Date</th> </tr> </thead> <tbody> <tr> <td>A300</td> <td>Building Sections</td> <td>Russell & Dawson, Inc.</td> <td>12 Oct 21</td> </tr> <tr> <td>A301</td> <td>Building Sections</td> <td>Russell & Dawson, Inc.</td> <td>12 Oct 21</td> </tr> <tr> <td>A302</td> <td>Building Sections</td> <td>Russell & Dawson, Inc.</td> <td>12 Oct 21</td> </tr> </tbody> </table>	No.	Title	Plan By	Date	A300	Building Sections	Russell & Dawson, Inc.	12 Oct 21	A301	Building Sections	Russell & Dawson, Inc.	12 Oct 21	A302	Building Sections	Russell & Dawson, Inc.	12 Oct 21												
No.	Title	Plan By	Date																										
A300	Building Sections	Russell & Dawson, Inc.	12 Oct 21																										
A301	Building Sections	Russell & Dawson, Inc.	12 Oct 21																										
A302	Building Sections	Russell & Dawson, Inc.	12 Oct 21																										
9.	Climate Change Narrative & Flood Design Affidavit - 09 Aug 2021																												
10.	PVI Site Design Letter of 22 Oct 21.																												



Massachusetts Department of Environmental Protection
Bureau of Resource Protection - Wetlands

WPA Form 3 – Notice of Intent

Massachusetts Wetlands Protection Act M.G.L. c. 131, §40

Provided by MassDEP:

MassDEP File Number

Document Transaction Number

EAST BOSTON

City/Town

C. Other Applicable Standards and Requirements (cont'd)

- (c) MESA filing fee (fee information available at <https://www.mass.gov/how-to/how-to-file-for-a-mesa-project-review>).

Make check payable to “Commonwealth of Massachusetts - NHESP” and **mail to NHESP** at above address

Projects altering 10 or more acres of land, also submit:

- (d) Vegetation cover type map of site
- (e) Project plans showing Priority & Estimated Habitat boundaries
- (f) OR Check One of the Following

1. Project is exempt from MESA review.
Attach applicant letter indicating which MESA exemption applies. (See 321 CMR 10.14, <https://www.mass.gov/service-details/exemptions-from-review-for-projectsactivities-in-priority-habitat>; the NOI must still be sent to NHESP if the project is within estimated habitat pursuant to 310 CMR 10.37 and 10.59.)

2. Separate MESA review ongoing. _____ a. NHESP Tracking # _____ b. Date submitted to NHESP

3. Separate MESA review completed.
Include copy of NHESP “no Take” determination or valid Conservation & Management Permit with approved plan.

3. For coastal projects only, is any portion of the proposed project located below the mean high water line or in a fish run?

- a. Not applicable – project is in inland resource area only b. Yes No

If yes, include proof of mailing, hand delivery, or electronic delivery of NOI to either:

South Shore - Cohasset to Rhode Island border, and
the Cape & Islands:

North Shore - Hull to New Hampshire border:

Division of Marine Fisheries -
Southeast Marine Fisheries Station
Attn: Environmental Reviewer
836 South Rodney French Blvd.
New Bedford, MA 02744
Email: dmf.envreview-south@mass.gov

Division of Marine Fisheries -
North Shore Office
Attn: Environmental Reviewer
30 Emerson Avenue
Gloucester, MA 01930
Email: dmf.envreview-north@mass.gov

Also if yes, the project may require a Chapter 91 license. For coastal towns in the Northeast Region, please contact MassDEP’s Boston Office. For coastal towns in the Southeast Region, please contact MassDEP’s Southeast Regional Office.

- c. Is this an aquaculture project? d. Yes No

If yes, include a copy of the Division of Marine Fisheries Certification Letter (M.G.L. c. 130, § 57).

U.S. Postal Service™
CERTIFIED MAIL® RECEIPT
Domestic Mail Only

For delivery information, visit our website at www.usps.com®.

Gloucester, MA 01930

OFFICIAL USE

Certified Mail Fee	\$3.75
\$	\$3.05
Extra Services & Fees (check box, add fee as appropriate)	
<input type="checkbox"/> Return Receipt (hardcopy)	\$0.00
<input type="checkbox"/> Return Receipt (electronic)	\$0.00
<input type="checkbox"/> Certified Mail Restricted Delivery	\$0.00
<input type="checkbox"/> Adult Signature Required	\$0.00
<input type="checkbox"/> Adult Signature Restricted Delivery	\$
Postage	\$1.36
\$	
Total F	
\$	



DMF \$8.16

Sent to:
Street:
City:

**NORTH SHORE OFFICE
ATTN: ENV. REVIEWER
30 EMERSON AVE
GLOUCESTER MA 10930**

structions

7017 0190 0000 5291 9184

SENDER: COMPLETE THIS SECTION

- Complete items 1, 2, and 3.
- Print your name and address on the reverse so that we can return the card to you.
- Attach this card to the back of the mailpiece, or on the front if space permits.

DMF
 NORTH SHORE OFFICE
 ATTN: ENV. REVIEWER
 30 EMERSON AVE
 GLOUCESTER MA 10930



9590 9402 5628 9308 2473 49

2. Article Number (Transfer from service label)

7017 0190 0000 5291 9184

COMPLETE THIS SECTION ON DELIVERY

A. Signature

X

DMF

Agent

Addressee

B. Received by (Printed Name)

DMF

C. Date of Delivery

9.20.21

D. Is delivery address different from item 1? Yes
 If YES, enter delivery address below: No

3. Service Type

- Adult Signature
- Adult Signature Restricted Delivery
- Certified Mail®
- Certified Mail Restricted Delivery
- Collect on Delivery
- Collect on Delivery Restricted Delivery
- Insured Mail
- Insured Mail Restricted Delivery (over \$500)

- Priority Mail Express®
- Registered Mail™
- Registered Mail Restricted Delivery
- Return Receipt for Merchandise
- Signature Confirmation™
- Signature Confirmation Restricted Delivery

Tuesday, July 27, 2021

To Whom It May Concern:

The following is a true and accurate translation of the original documents that were presented to TELELANGUAGE Inc.

Document Name/Description = 9B - English Abutter Notification COVID-19 Form

Requestor Name = Ivas Environmental

I certify that I am an authorized representative of TELELANGUAGE Inc, a member of good standing with the American Translators Association. I further certify that this text was translated by a competent professional translator who is fluent in English and Spanish and translated this text from English to Spanish.

MS

Monica Sexton
Translation Coordinator



**NOTIFICACIÓN A PROPIETARIOS COLINDANTES
COMISIÓN DE CONSERVACIÓN DE BOSTON**

De conformidad con la Ley de Protección de Humedales de Massachusetts, las Leyes Generales de Massachusetts, capítulo 131, sección 40, y la Ordenanza de Humedales de Boston, por la presente se lo notifica como propietario colindante de un proyecto presentado ante la Comisión de Conservación de Boston.

A. **A. Patel** ha presentado un Aviso de Intención ante la Comisión de Conservación de Boston en la que solicita autorización para alterar una zona sujeta a protección bajo la Ley de Protección de Humedales (Leyes Generales, capítulo 31, sección 40) y la Ordenanza de Humedales de Boston.

B. La dirección del lote donde se propone llevar a cabo la actividad es **155 Porter Street, East Boston.**

C. El proyecto supone la **transformación de un edificio de cinco pisos en un hotel, con dos playas de estacionamiento, adyacentes a las calles Orleans y Frankfort.**

D. Para obtener copias del Aviso de Intención es necesario comunicarse con la Comisión de Conservación de Boston, **CC@boston.gov**.

E. Se pueden obtener copias del Aviso de Intención a través de: **Ivas Environmental, llamando al 781.659.1690 o escribiendo a spivas@comcast.net de lunes a viernes entre las 9 a.m. y las 5 p.m.**

F. De conformidad con la Orden Ejecutiva de la Mancomunidad de Massachusetts que suspende determinadas disposiciones de la Ley de Reuniones Abiertas, la audiencia pública se llevará a cabo de manera **virtual** en **<https://zoom.us/j/6864582044>**. Si no tiene acceso a Internet, puede llamar al 1-929-205-6099, ingresar el número de identificación de la reunión 686 458 2044 y usar # como su identificación de participante.

G. Se puede obtener información acerca de la fecha y hora de la audiencia pública a través de la **Comisión de Conservación de Boston** por correo electrónico **Cc@boston.gov** o llamando al **(617) 635-3850 de lunes a viernes entre las 9 a.m. y las 5 p.m.**

NOTA: El aviso de la audiencia pública, incluida la fecha, la hora y el lugar, se publicará al menos cinco (5) días antes en el **Boston Herald**.

NOTA: El aviso de la audiencia pública, incluida la fecha, la hora y el lugar, se publicará en **www.boston.gov/public-notices** y en el Ayuntamiento de la ciudad de Boston con una anticipación no inferior a cuarenta y ocho (48) horas.

NOTA: Si desea hacer comentarios, puede asistir a la audiencia pública o enviar comentarios por escrito a **CC@boston.gov** o al Ayuntamiento de la ciudad de Boston, Departamento de medio ambiente, Sala 709, 1 City Hall Square, Boston, MA 02201

NOTA: También puede ponerse en contacto con la Comisión de Conservación de Boston o el Departamento de Protección Ambiental, Oficina Regional Noreste, para obtener información acerca de esta solicitud o la Ley de Protección de Humedales. Para comunicarse con el Departamento, llame a la Región Noreste: (978) 694-3200.



<u>Resource Area</u>	<u>Resource Area Size</u>	<u>Proposed Alteration*</u>	<u>Proposed Mitigation</u>
<input type="checkbox"/> Coastal Flood Resilience Zone	_____ Square feet	_____ Square feet	_____ Square feet
<input type="checkbox"/> 25-foot Waterfront Area	_____ Square feet	_____ Square feet	_____ Square feet
<input type="checkbox"/> 100-foot Salt Marsh Area	_____ Square feet	_____ Square feet	_____ Square feet
<input type="checkbox"/> Riverfront Area	_____ Square feet	_____ Square feet	_____ Square feet

2. Inland Resource Areas

<u>Resource Area</u>	<u>Resource Area Size</u>	<u>Proposed Alteration*</u>	<u>Proposed Mitigation</u>
<input type="checkbox"/> Inland Flood Resilience Zone	_____ Square feet	_____ Square feet	_____ Square feet
<input type="checkbox"/> Isolated Wetlands	_____ Square feet	_____ Square feet	_____ Square feet
<input type="checkbox"/> Vernal Pool	_____ Square feet	_____ Square feet	_____ Square feet
<input type="checkbox"/> Vernal Pool Habitat (vernal pool + 100 ft. upland area)	_____ Square feet	_____ Square feet	_____ Square feet
<input type="checkbox"/> 25-foot Waterfront Area	_____ Square feet	_____ Square feet	_____ Square feet
<input type="checkbox"/> Riverfront Area	_____ Square feet	_____ Square feet	_____ Square feet

C. OTHER APPLICABLE STANDARDS & REQUIREMENTS

1. What other permits, variances, or approvals are required for the proposed activity described herein and what is the status of such permits, variances, or approvals?

- _____
BRA / BPDA Approval - 10 Dec 2015
- _____
ZBA Variances Granted - 11 Dec 2018
- _____
Board of Appeal - Decision Extended Until 15 Mar 2022
- _____
ISD - Final Building Permit - Expected after OOC from Conservation Commission
- _____
BWSC Approval - 09 May 2018; BWSC Cross-Connection Approval - 06 May 2018

NOTE: Project filings should be prepared and submitted using the online [Climate Resiliency Checklist](#).

A.1 - Project Information

Project Name:	Boston Hotel		
Project Address:	155 Porter Street, Boston, MA 02128		
Project Address Additional:			
Filing Type (select)	<i>Building Permit (prior to final design approval)</i>		
Filing Contact	<i>Utkarsh Patil</i>	<i>Russell and Dawson</i>	<i>utkarsh.patil@rda ep.com</i> (860) 289-1100
Is MEPA approval required	<i>No</i>		<i>3/14/2018</i>

A.3 - Project Team

Owner / Developer:	<i>Russell and Dawson</i>
Architect:	<i>Russell and Dawson</i>
Engineer:	<i>Russell and Dawson</i>
Sustainability / LEED:	<i>The Green Engineer, Inc.</i>
Permitting:	<i>Epsilon</i>
Construction Management:	<i>TBD</i>

A.3 - Project Description and Design Conditions

List the principal Building Uses:	<i>Hotel</i>
List the First Floor Uses:	<i>Front Desk, Dining, Amenity, BOH</i>
List any Critical Site Infrastructure and or Building Uses:	

Site and Building:

Site Area:	<i>50, 328 SF</i>	Building Area:	<i>64709 SF</i>
Building Height:	<i>71'-3"Ft</i>	Building Height:	<i>5 Stories</i>
Existing Site Elevation - Low:	<i>14.8 Ft BCB</i>	Existing Site Elevation - High:	<i>25.89 Ft BCB</i>
Proposed Site Elevation - Low:	<i>10.0 Ft BCB</i>	Proposed Site Elevation - High:	<i>25.89 Ft BCB</i>
Proposed First Floor Elevation:	<i>18.2 Ft BCB</i>	Below grade levels:	<i>1 stories</i>

Article 37 Green Building:

LEED Version - Rating System :	<i>LEED NC-v4</i>	LEED Certification:	<i>Yes</i>
Proposed LEED rating:	<i>Silver</i>	Proposed LEED point score:	<i>58 Pts.</i>

Building Envelope

When reporting R values, differentiate between R discontinuous and R continuous. For example, use “R13” to show R13 discontinuous and use R10c.i. to show R10 continuous. When reporting U value, report total assembly U value including supports and structural elements.

Roof:	R-31.25	Exposed Floor:	Not insulated
Foundation Wall:	N/A	Slab Edge (at or below grade):	Not insulated

Vertical Above-grade Assemblies (%'s are of total vertical area and together should total 100%):

Area of Opaque Curtain Wall & Spandrel Assembly:	0(%)	Wall & Spandrel Assembly Value:	R-11.76
Area of Framed & Insulated / Standard Wall:	39.78 (%)	Wall Value	R-11.76
Area of Vision Window:	60(%)	Window Glazing Assembly Value:	U-0.3
		Window Glazing SHGC:	SHGC = 0.37
Area of Doors:	0.22%	Door Assembly Value:	0.3(U)

Energy Loads and Performance

For this filing – describe how energy loads & performance were determined

The performance and the overall energy use was estimated using eQUEST energy modeling tool based on the information provided by the design team.

Annual Electric:	727,966 kWh	Peak Electric:	748.8(kW)
Annual Heating:	1,083 MMbtu	Peak Heating:	1.73(MMbtu)
Annual Cooling:	193 MMbtu	Peak Cooling:	150(Tons)
Energy Use - Below ASHRAE 90.1 - 2013:	8.3 %	Have the local utilities reviewed the building energy performance?	Yes
Energy Use - Below Mass. Code:	8.3 %	Energy Use Intensity:	56.7 kBtu/SF

Back-up / Emergency Power System

Electrical Generation Output:	125 kW	Number of Power Units:	Two
System Type:	Emergency power application	Fuel Source:	Natural gas

Emergency and Critical System Loads (in the event of a service interruption)

Electric:	88.9(kW)	Heating:	0 MMbtu/hr
		Cooling:	0 Tons/hr

B – Greenhouse Gas Reduction and Net Zero / Net Positive Carbon Building Performance

Reducing GHG emissions is critical to avoiding more extreme climate change conditions. To achieve the City's goal of carbon neutrality by 2050 new buildings performance will need to progressively improve to net carbon zero and positive.

B.1 – GHG Emissions - Design Conditions

For this Filing - Annual Building GHG Emissions: 311(Tons)

For this filing - describe how building energy performance has been integrated into project planning, design, and engineering and any supporting analysis or modeling:

The project team used energy modeling during the design phases to identify appropriate energy efficiency targets

Describe building specific passive energy efficiency measures including orientation, massing, envelop, and systems:

The building has a high-performance glazing system

Describe building specific active energy efficiency measures including equipment, controls, fixtures, and systems:

The design includes high efficiency MEP systems and local controls, reduced LPD fixtures and a BAS for effective and efficient control of systems.

Describe building specific load reduction strategies including on-site renewable, clean, and energy storage systems:

The building uses high efficiency VRV hvac systems for heating and cooling, combined with LED fixtures for energy efficiency. The big windows in all rooms provides ample natural light and reduces lighting load.

Describe any area or district scale emission reduction strategies including renewable energy, central energy plants, distributed energy systems, and smart grid infrastructure:

Describe any energy efficiency assistance or support provided or to be provided to the project:

The project is pursuing incentives through the MassSave program

B.2 - GHG Reduction - Adaptation Strategies

Describe how the building and its systems will evolve to further reduce GHG emissions and achieve annual carbon net zero and net positive performance (e.g. added efficiency measures, renewable energy, energy storage, etc.) and the timeline for meeting that goal (by 2050):

In the future, when the base building systems components need to be replaced the new components will be state of the art (at the time) and in all likelihood more energy efficient than the initial systems.

C - Extreme Heat Events

Annual average temperature in Boston increased by about 2° F in the past hundred years and will continue to rise due to climate change. By the end of the century, the average annual temperature could be 56° (compared to 46° now) and the number of days above 90° (currently about 10 a year) could rise to 90.

C.1 – Extreme Heat - Design Conditions

Temperature Range - Low:	6 Deg.	Temperature Range - High:	91 Deg.
Annual Heating Degree Days:	5596	Annual Cooling Degree Days:	750

What Extreme Heat Event characteristics will be / have been used for project planning

Days - Above 90°:	14	Days - Above 100°:	0
Number of Heatwaves / Year:	3	Average Duration of Heatwave (Days):	0

Describe all building and site measures to reduce heat-island effect at the site and in the surrounding area:

We have maximized the green space on the site by introducing landscape and green roof on the building.

C.2 - Extreme Heat – Adaptation Strategies

Describe how the building and its systems will be adapted to efficiently manage future higher average temperatures, higher extreme temperatures, additional annual heatwaves, and longer heatwaves:

The building utilizes low-e window glazing, combined with low energy consumption hvac units.

Describe all mechanical and non-mechanical strategies that will support building functionality and use during extended interruptions of utility services and infrastructure including proposed and future adaptations:

To prepare for future power interruptions, future adaptations can be made to equip the building hvac with generator backup and install solar panels on the roof and as carports in the parking lot.

D - Extreme Precipitation Events

From 1958 to 2010, there was a 70 percent increase in the amount of precipitation that fell on the days with the heaviest precipitation. Currently, the 10-Year, 24-Hour Design Storm precipitation level is 5.25". There is a significant probability that this will increase to at least 6" by the end of the century. Additionally, fewer, larger storms are likely to be accompanied by more frequent droughts.

D.1 – Extreme Precipitation - Design Conditions

10 Year, 24 Hour Design Storm: 4.6 In.

Describe all building and site measures for reducing storm water run-off:

The site design reduces the overall impervious area of the site. A new stormwater infiltration system is proposed to infiltrate the first 1" or rainfall.

D.2 - Extreme Precipitation - Adaptation Strategies

Describe how site and building systems will be adapted to efficiently accommodate future more significant rain events (e.g. rainwater harvesting, on-site storm water retention, bio swales, green roofs):

The site utilizes on-site retention to reduce runoff from leaving the property.

E – Sea Level Rise and Storms

Under any plausible greenhouse gas emissions scenario, sea levels in Boston will continue to rise throughout the century. This will increase the number of buildings in Boston susceptible to coastal flooding and the likely frequency of flooding for those already in the floodplain.

Is any portion of the site in a FEMA SFHA?	Yes	What Zone:	AE
Current FEMA SFHA Zone Base Flood Elevation:			16.46 Ft BCB

Is any portion of the site in a BPDA Sea Level Rise - Flood Hazard Area? Use the online BPDA SLR-FHA Mapping Tool to assess the susceptibility of the project site.	Yes
---	-----

If you answered YES to either of the above questions, please complete the following questions. Otherwise you have completed the questionnaire; thank you!

E.1 – Sea Level Rise and Storms – Design Conditions

Proposed projects should identify immediate and future adaptation strategies for managing the flooding scenario represented on the BPDA Sea Level Rise - Flood Hazard Area (SLR-FHA) map, which depicts a modeled 1% annual chance coastal flood event with 40 inches of sea level rise (SLR). Use the online [BPDA SLR-FHA Mapping Tool](#) to identify the highest Sea Level Rise - Base Flood Elevation for the site. The Sea Level Rise - Design Flood Elevation is determined by adding either 24” of freeboard for critical facilities and infrastructure and any ground floor residential units OR 12” of freeboard for other buildings and uses.

Sea Level Rise - Base Flood Elevation:	19.3 Ft BCB		
Sea Level Rise - Design Flood Elevation:	20.3 Ft BCB	First Floor Elevation:	18.2 Ft BCB
Site Elevations at Building:	18.2 Ft BCB	Accessible Route Elevation:	18.2 Ft BCB

Describe site design strategies for adapting to sea level rise including building access during flood events, elevated site areas, hard and soft barriers, wave / velocity breaks, storm water systems, utility services, etc.:

One of the exit stairs currently discharges at 25.9 BCB. The other exit stair will have provisions to exit above sea level rise DFE.

Describe how the proposed Building Design Flood Elevation will be achieved including dry / wet flood proofing, critical systems protection, utility service protection, temporary flood barriers, waste and drain water back flow prevention, etc.:

The building gk]HW[YUfzHfUbgZcfa Yf UbX[YbYfUrcf k]`VY`d`UWX`cb U & (``\] \ ` d`Uhzfa `tc`a YYhXZY`fYei]fYa Ybrg" Electrical panels from basement relocated.

Describe how occupants might shelter in place during a flooding event including any emergency power, water, and wastewater provisions and the expected availability of any such measures:

The building is equipped with backup generators and there is a possibility of having solar energy in the future that would support shelter taken by occupants during any emergency situations.

Describe any strategies that would support rapid recovery after a weather event:

The existing building is cast-in-place concrete which is inherently resistant to the weather adversities.

E.2 – Sea Level Rise and Storms – Adaptation Strategies

Describe future site design and or infrastructure adaptation strategies for responding to sea level rise including future elevating of site areas and access routes, barriers, wave / velocity breaks, storm water systems, utility services, etc.:

To cope with sea level rise, there is a future possibility of raising the first-floor level by 2'. The site design would follow along on the possibility of raising the site areas. The ample floor to floor height of the existing building would allow this change to be possible.

Describe future building adaptation strategies for raising the Sea Level Rise Design Flood Elevation and further protecting critical systems, including permanent and temporary measures:

K Y'dfcdcgY`Yj Uh]b[`Vi]X]b[`gk]hW[YUfz[YbYfUhc'UbX'hfUbgZcfa Yf'cb'U'&(' high concrete platform and modify stair 2 for raising floor above future BFE.

A pdf and word version of the Climate Resiliency Checklist is provided for informational use and off-line preparation of a project submission. **NOTE: Project filings should be prepared and submitted using the online [Climate Resiliency Checklist](#).**

For questions or comments about this checklist or Climate Change best practices, please contact: John.Dalzell@boston.gov

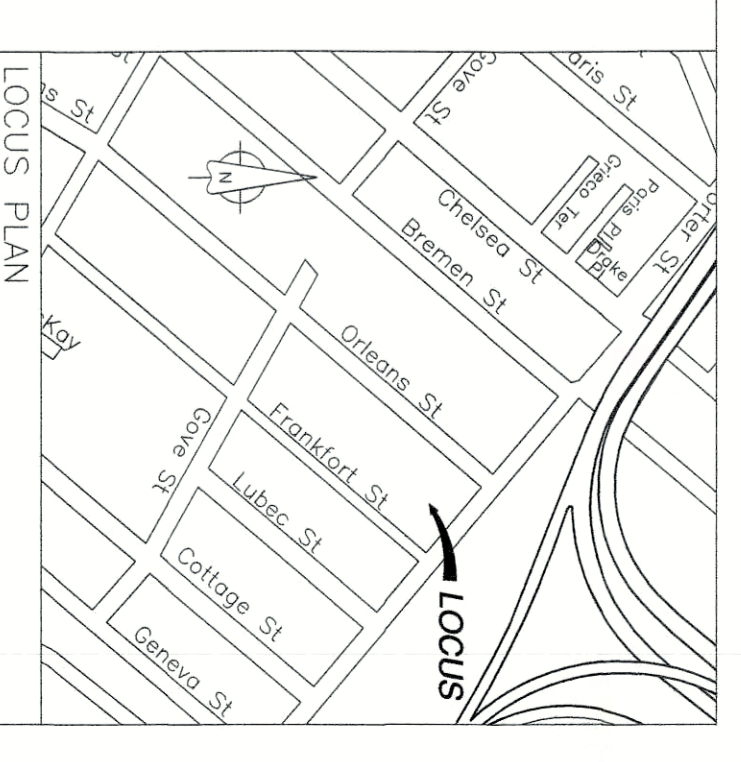

Site Plan
Land in
BOSTON,
(East Boston),
Suffolk County,
Massachusetts

Record Owner:
183 Orleans Street, LLC
Deed Book 52219, page 157
Deed Book 57405, page 188

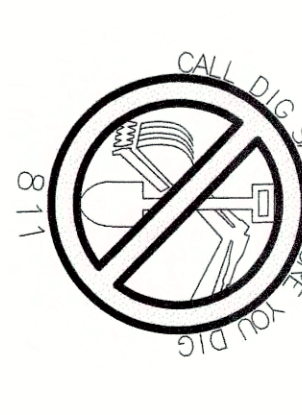

DATE: February 15, 2017
REV/Apr. 6, 2017
REV/Sep. 28, 2021 Revised as to
FEMA Flood Zone Line Only

© 2017 ALL RIGHTS RESERVED
ANDERSON SURVEYS, INC.
Professional Land Surveyors
800 HIGH STREET
HANSON, MA 02341-0149
(781) 293-3349
kanderson@andersonsurveys.com
SCALE: 1" = 16'

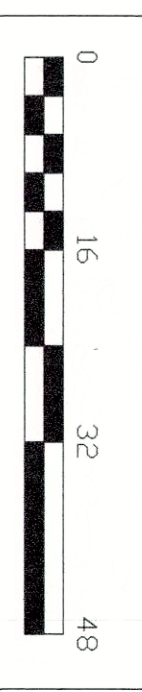

RESERVED FOR REGISTRY OF DEEDS



Kenneth B. Anderson, PLS# 31298

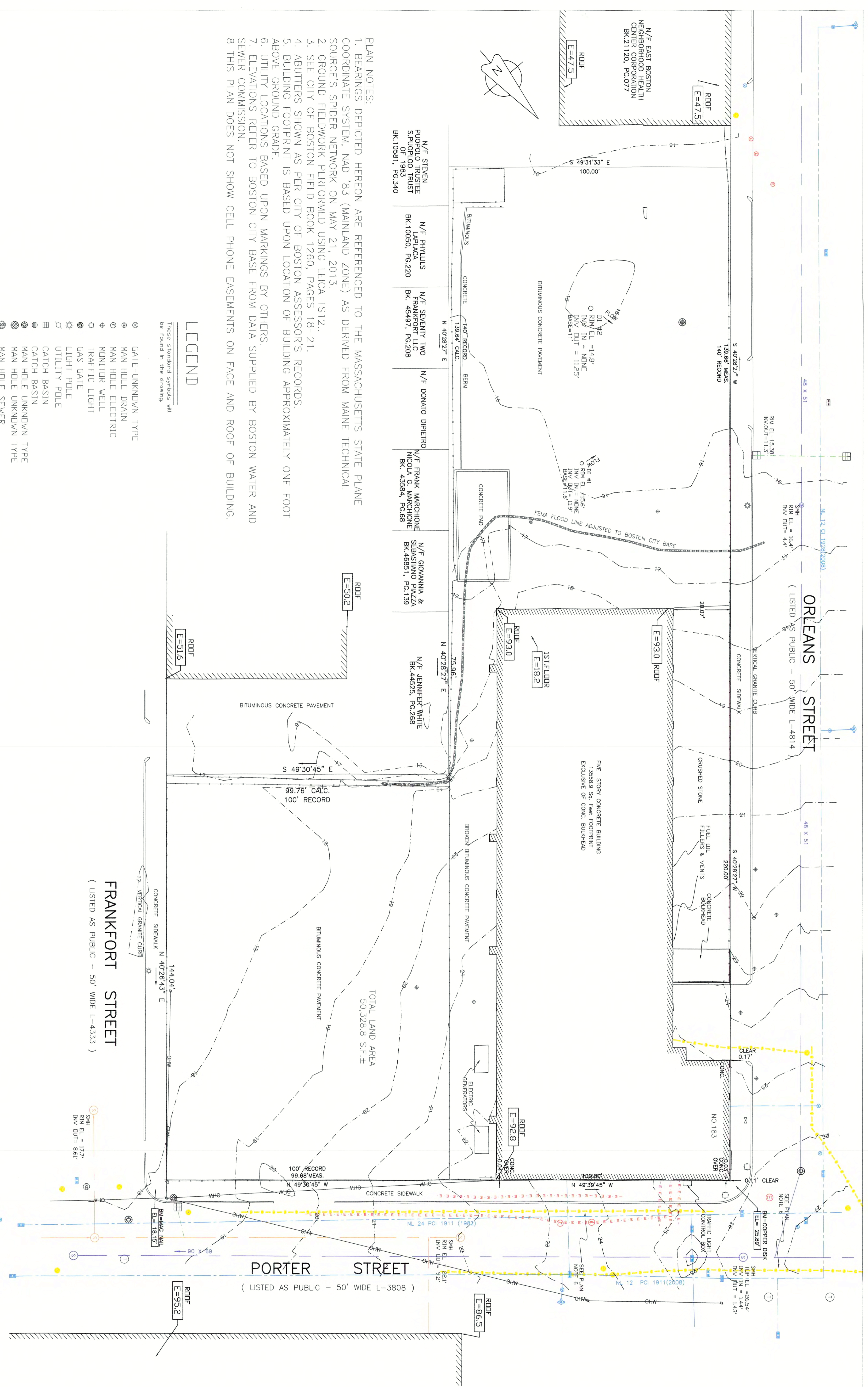

- PLAN NOTES:
1. BEARINGS DEPICTED HEREON ARE REFERENCED TO THE MASSACHUSETTS STATE PLANE COORDINATE SYSTEM, NAD '83 (MAINLAND ZONE) AS DERIVED FROM MAINE TECHNICAL SOURCE'S SPIDER NETWORK ON MAY 21, 2013.
 2. GROUND FIELDWORK PERFORMED USING LEICA TS12..
 3. SEE CITY OF BOSTON FIELD BOOK 1260, PAGES 18-21.
 4. ABUTTERS SHOWN AS PER CITY OF BOSTON ASSESSOR'S RECORDS.
 5. BUILDING FOOTPRINT IS BASED UPON LOCATION OF BUILDING APPROXIMATELY ONE FOOT ABOVE GROUND GRADE.
 6. UTILITY LOCATIONS BASED UPON MARKINGS BY OTHERS.
 7. ELEVATIONS REFER TO BOSTON CITY BASE FROM DATA SUPPLIED BY BOSTON WATER AND SEWER COMMISSION.
 8. THIS PLAN DOES NOT SHOW CELL PHONE EASEMENTS ON FACE AND ROOF OF BUILDING.

LEGEND

- These standard symbols will be found in the drawing.
- ⊗ GATE-UNKNOWN TYPE
 - ⊙ MAN HOLE DRAIN
 - ⊙ MAN HOLE ELECTRIC
 - ⊕ MONITOR WELL
 - ⊙ TRAFFIC LIGHT
 - ⊙ GAS GATE
 - ⊙ LIGHT POLE
 - ⊙ UTILITY POLE
 - ⊙ CATCH BASIN
 - ⊙ MAN HOLE UNKNOWN TYPE
 - ⊙ MAN HOLE UNKNOWN TYPE
 - ⊙ MAN HOLE SEWER
 - ⊙ CHAIN LINK FENCE
 - MARKED GAS LINE
 - MARKED ELECTRIC LINE
 - MARKED WATER LINE
 - ⊙ GATE-BWSC

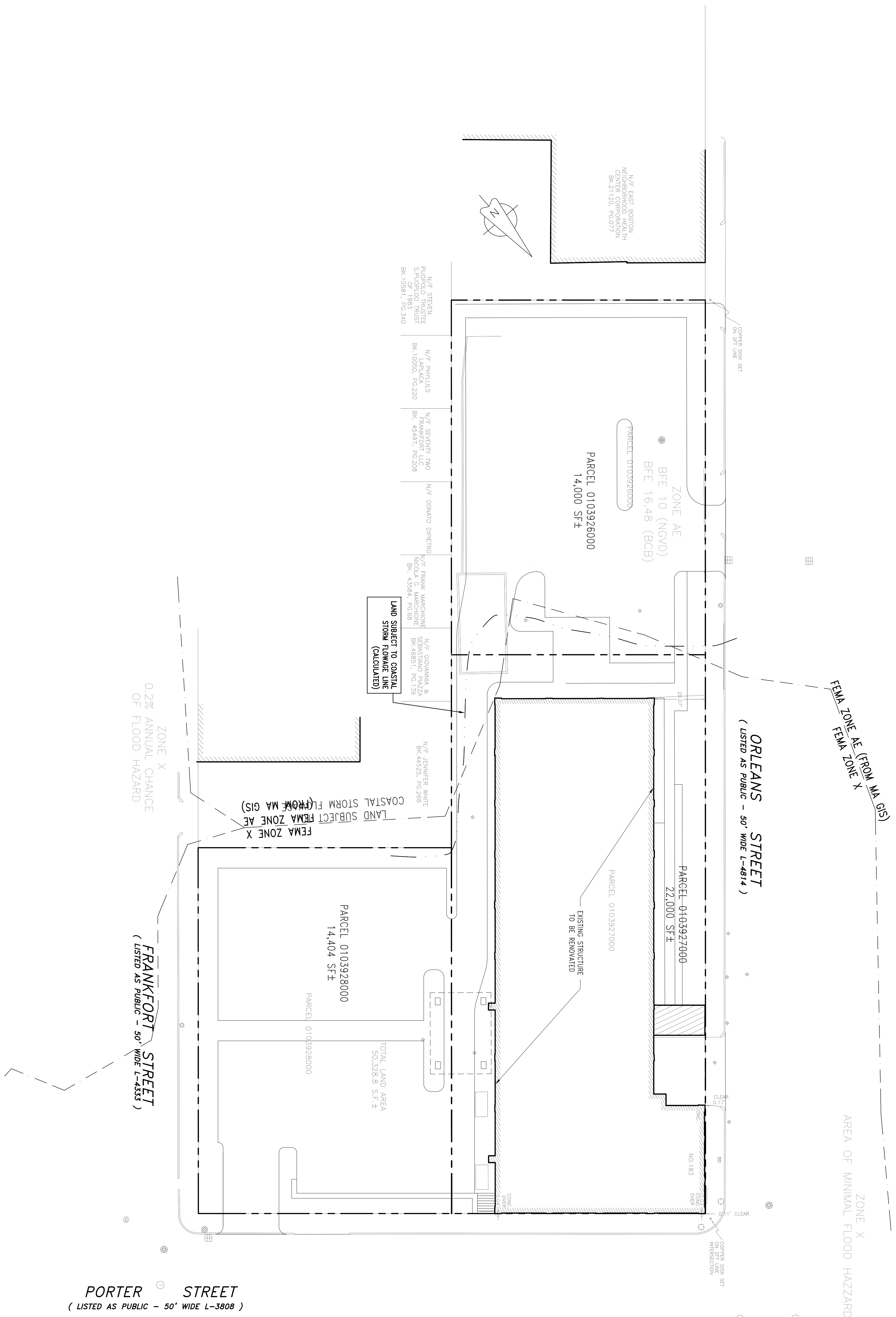

FOR BWSC USE ONLY

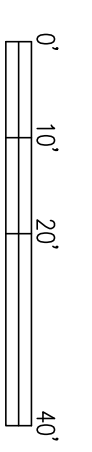

PL100 SHEET NO.	SCALE: 1"=20' JOB NO: 003-003 FILE: 003-003-PL01-PLAN.DWG DRAWN: TJP CHECKED: TJP SHEET NO.	ISSUED FOR CONSTRUCTION DECEMBER 8, 2017 PARCEL PLAN BWSC SITE PLAN #17410	SEAL: 	REV.: 6: 09-17-2019 BPDA COMMENTS 7: 11-26-2019 BPDA COMMENTS 8: 01-02-2020 BPDA COMMENTS 9: 11-20-2020 BPDA COMMENTS 10: 07-27-2021 NOI COMMENTS 11: 10-20-2021 FEMA / LSCSF LINE	PROJECT: HOTEL REDEVELOPMENT 155 PORTER STREET, EAST BOSTON, MA CLIENT / APPLICANT: HUDSON 62 REALTY LLC 440 BEDFORD ST, LEXINGTON, MA 01824	CIVIL ENGINEER: PVI Site Design, LLC Civil Engineering - Land Entitlements Master Planning - Project Management 339-206-1030
---------------------------	--	--	-----------	--	---	--

SITE PREPARATION NOTES

- WITHIN THE LIMIT OF THE WORK LINE AS NOTED ON THE SITE PREPARATION PLAN, REMOVE AND DISCARD ALL CONCRETE PAVEMENT, BITUMINOUS CONCRETE PAVEMENT, BRICK PAVEMENT, TOP 4" CURB, ALUMINUM TRASH, DECKING AND UTILITY SCRUBBER, CHAIN LINK FENCE POSTS, FALS, FABRIC, GATES, FENCINGS AND ALL APPURTENANCES, BOLLARDS, POSTS, CONCRETE FOOTINGS AND FOUNDATIONS, WALLS AND CURBS UNLESS OTHERWISE NOTED.
- THE OWNER'S REPRESENTATIVE SHALL BE CONSULTED AND WILL REVIEW THE WORK ON SITE WITH THE CONTRACTOR BEFORE ANY WORK SHALL COMMENCE.
- THE CONTRACTOR SHALL VERIFY ALL EXISTING CONDITIONS IN THE FIELD AND REPORT ANY DISCREPANCIES BETWEEN PLANS AND ACTUAL CONDITIONS TO THE OWNER'S REPRESENTATIVE PRIOR TO STARTING WORK.
- THE CONTRACTOR IS RESPONSIBLE FOR ANY DAMAGE TO EXISTING CONDITIONS TO REPAIR THAT ARE DUE TO CONTRACTOR OPERATIONS.
- ALL ITEMS TO BE REMOVED THAT ARE NOT STOCKPILED FOR LATER REUSE ON THE PROJECT OR DELIVERED TO THE OWNER SHALL BE LEGALLY DISPOSED OF OFF SITE BY THE CONTRACTOR.
- THE CONTRACTOR SHALL BE RESPONSIBLE FOR COORDINATING HIS EFFORTS OF THE DEMOLITION WITH ALL TRADERS.
- THE CONTRACTOR SHALL MAINTAIN OR ADJUST TO NEW FINISH GRADE AS NECESSARY ALL UTILITY AND SITE STRUCTURES SUCH AS MANHOLE SYSTEMS, POLES, LIGHTS, CONCRETE WALLS, CURBS, AND BOLLARDS TO BE MAINTAINED FROM THE FINISH GRADE UNLESS OTHERWISE NOTED ON SHEETS BY THE OWNER'S REPRESENTATIVE.

GENERAL CONSTRUCTION SEQUENCE

- CONSTRUCT TEMPORARY AND PERMANENT EROSION CONTROL MEASURES. ALL EROSION AND SEDIMENTATION CONTROL MEASURES SHALL BE INSTALLED PRIOR TO ANY SITE EXCAVATION OR DISTURBANCE AND SHALL BE MAINTAINED THROUGHOUT THE CONSTRUCTION PROCESS. THE SMALLEST PRACTICAL AREA OF LAND SHALL BE EXPOSED AT ANY ONE TIME.
- DEMOLISH AND DISPOSE OF EXISTING SITE ELEMENTS NOT TO REMAIN.
- GRADE AND GRAVEL ALL PAVED AREAS. ALL PROPOSED PAVED AREAS SHALL BE STABILIZED IMMEDIATELY AFTER GRADING.
- BEGIN ALL REMAINING AND TEMPORARY SEEDING AND MULCHING. ALL CUT AND FILL SLOPES SHALL BE SEEDED AND MULCHED IMMEDIATELY AFTER THEIR CONSTRUCTION.
- DAILY OR AS REQUIRED, CONSTRUCT TEMPORARY BERMS, DRENCH DITCHES, Silt FENCES TO PREVENT SEDIMENTATION INTO THE PUBLIC WAY.
- FINISH PAVING ALL HARD SURFACE AREAS.
- INSPECT AND MAINTAIN ALL EROSION AND SEDIMENT CONTROL MEASURES.
- COMPLETE PERMANENT SEEDING AND LANDSCAPING.
- REMOVE TEMPORARY EROSION CONTROL MEASURES.
- THE CONSTRUCTION SEQUENCE SHALL BE CONFINED TO THE LIMIT OF WORK AS SHOWN ON THE DRAWINGS.

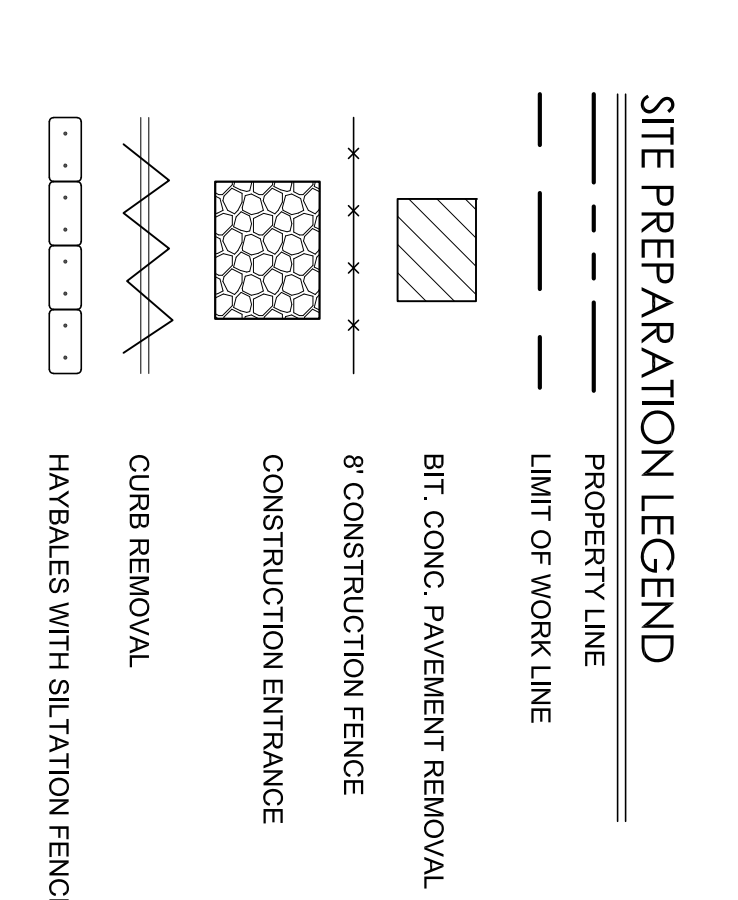
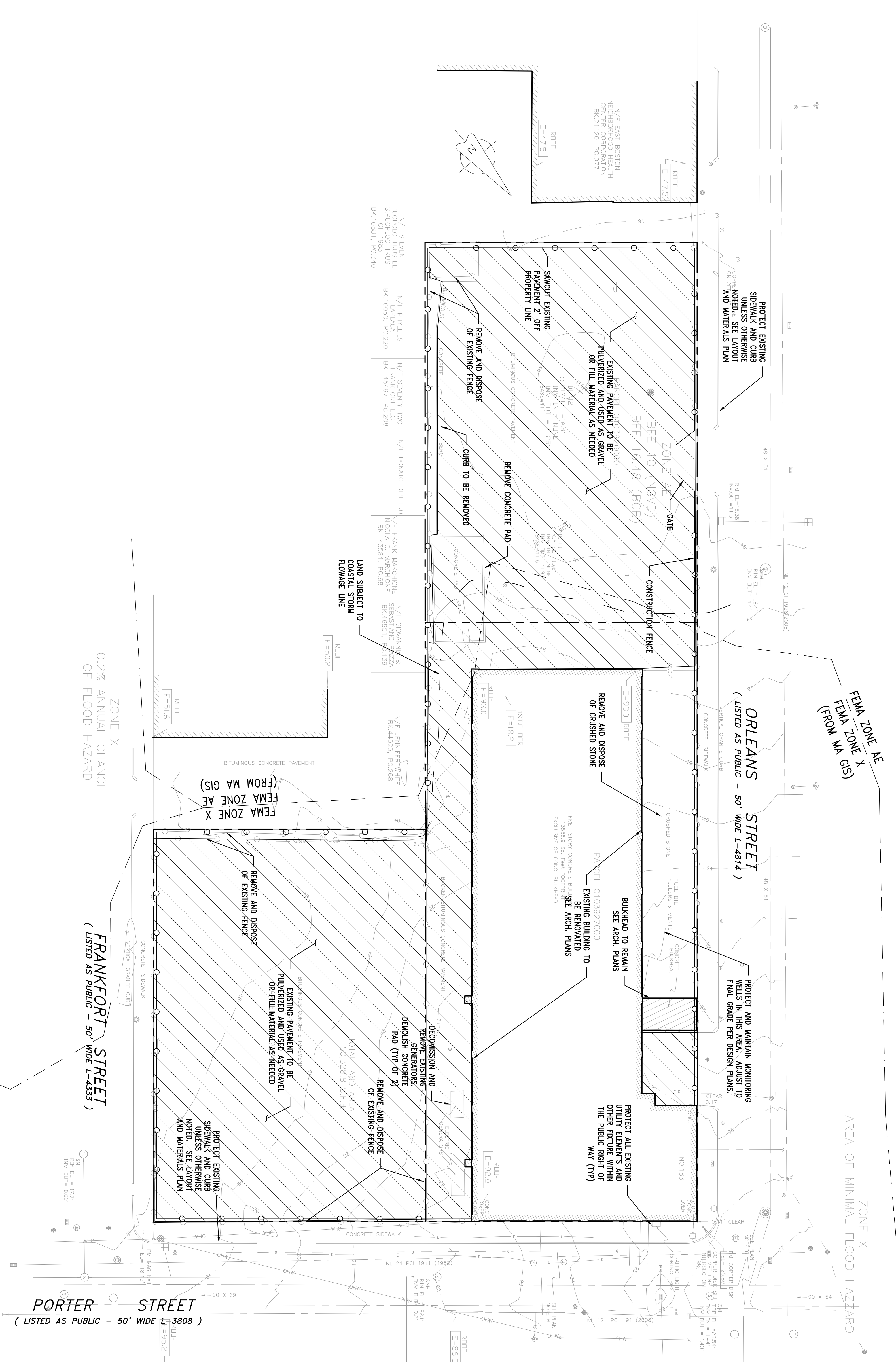
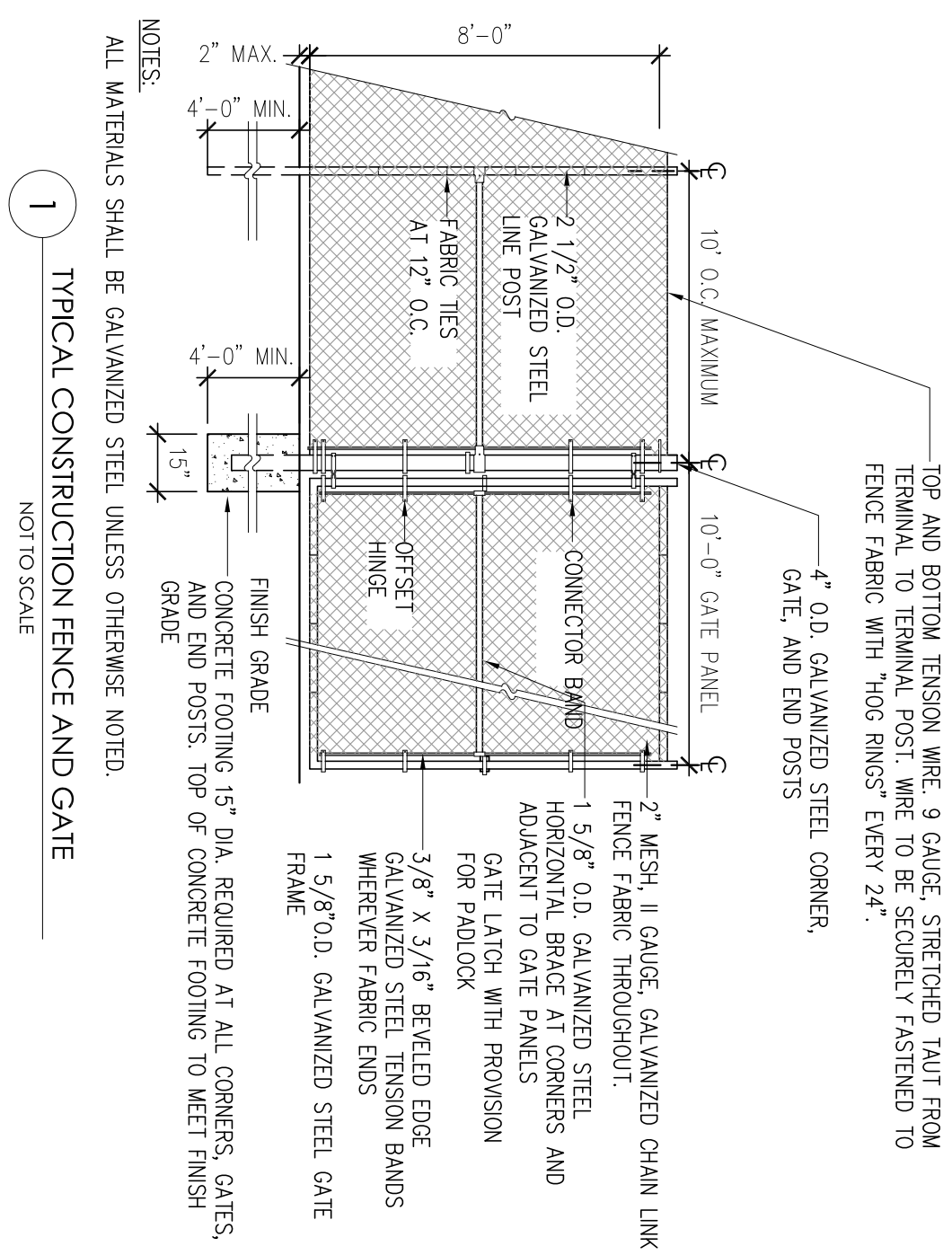

PVI SITE DESIGN
PVI Site Design, LLC
Civil Engineering - Land Entitlements
Master Planning - Project Management
339-206-1030

CIVIL ENGINEER:

HOTEL REDEVELOPMENT
155 PORTER STREET, EAST BOSTON, MA

CLIENT / APPLICANT:
HUDSON 62 REALTY LLC
440 BEDFORD ST, LEXINGTON, MA 01824

REV.:

6:	09-17-2019	BPDA COMMENTS
7:	11-26-2019	BPDA COMMENTS
8:	01-02-2020	BPDA COMMENTS
9:	11-20-2020	BPDA COMMENTS
10:	07-27-2021	NOI COMMENTS
11:	10-20-2021	FEMA / LSCSF LINE

SEAL:

ISSUED FOR CONSTRUCTION
DECEMBER 8, 2017

SITE PREPARATION PLAN

BWSC SITE PLAN #17410

SCALE: 1"=20'

JOB NO: 003-003
FILE: 003-003-SF.dwg
DRAWN: TJP
CHECKED: TJP
SHEET NO: C100

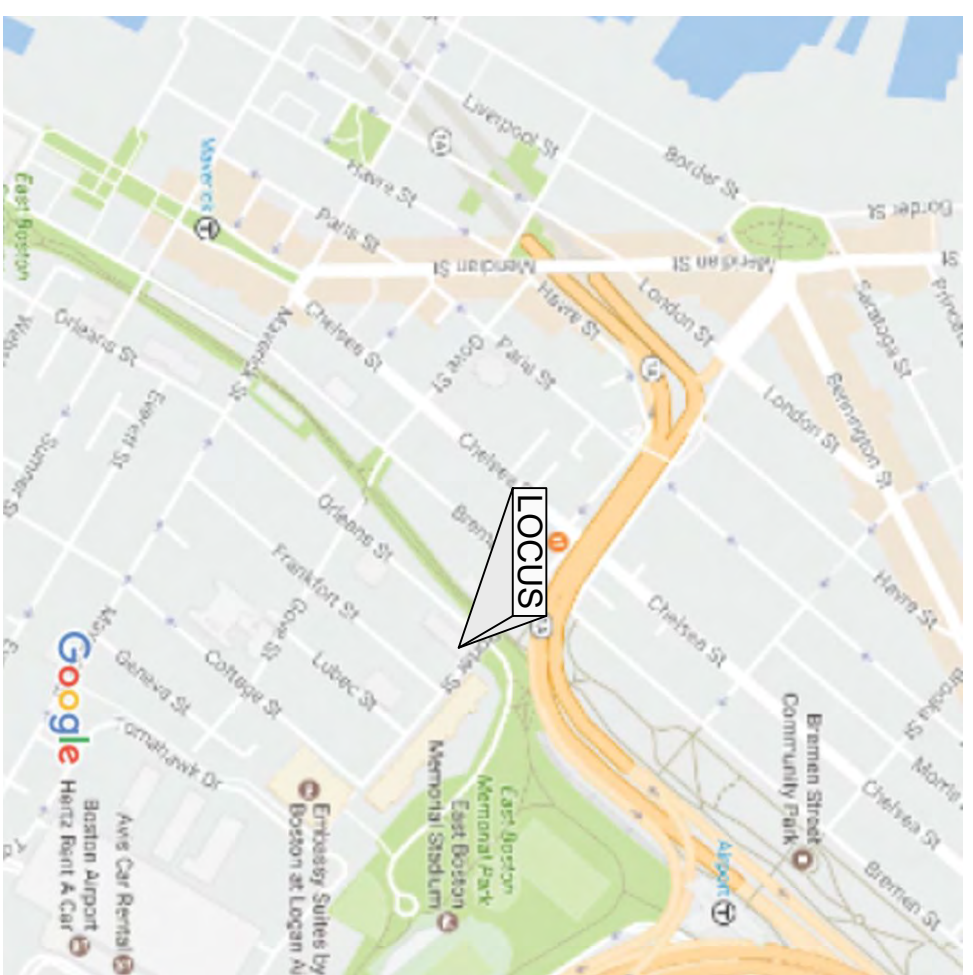

LOCUS
SCALE: 1" = 500'

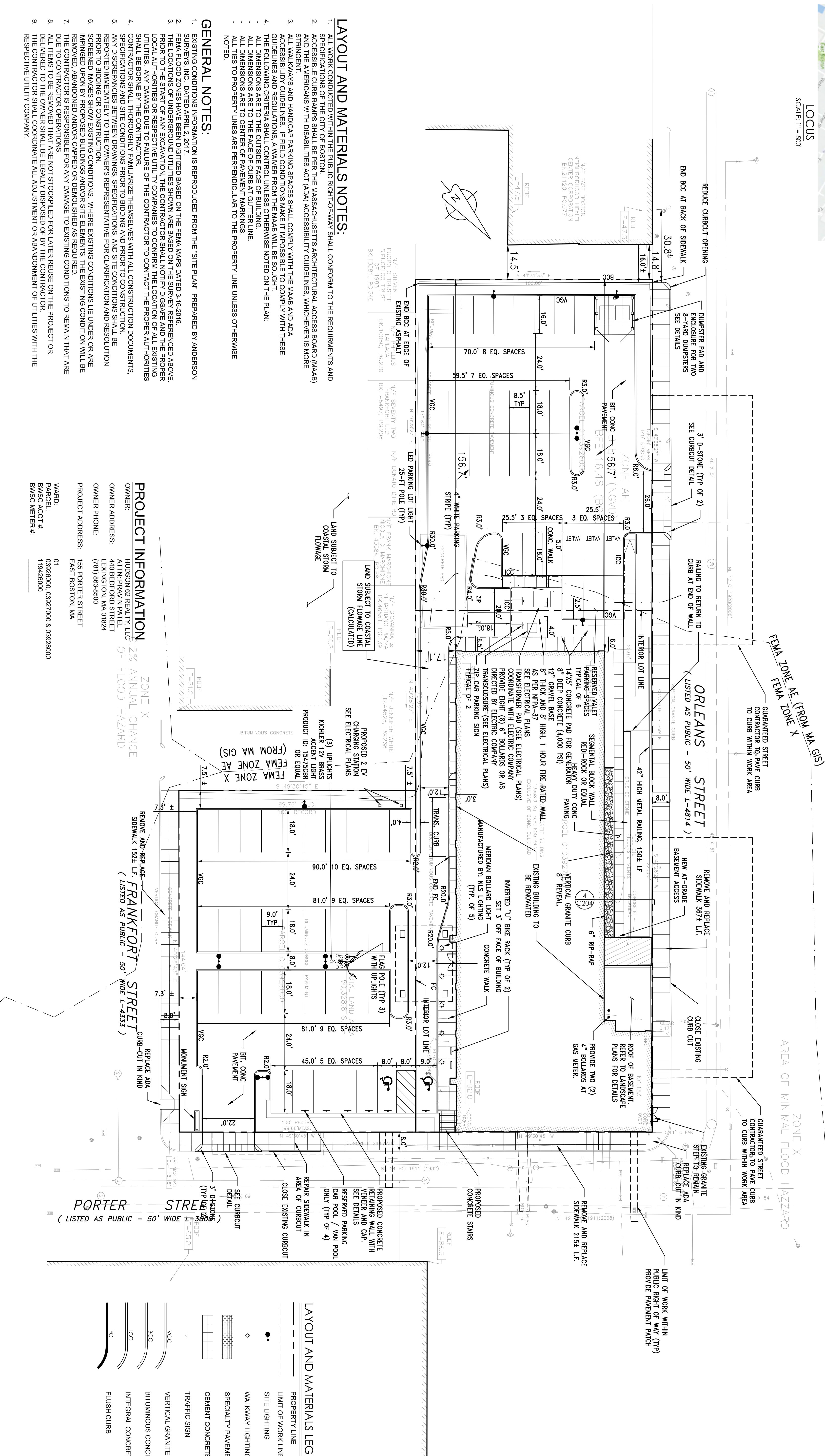

LAYOUT AND MATERIALS NOTES:

1. ALL WORK CONDUCTED WITHIN THE PUBLIC RIGHT-OF-WAY SHALL CONFORM TO THE REQUIREMENTS AND SPECIFICATIONS OF THE CITY OF BOSTON.
2. ACCESSIBLE CURB RAMPS SHALL BE PER THE MASSACHUSETTS ARCHITECTURAL ACCESS BOARD (MAAB) AND THE AMERICANS WITH DISABILITIES ACT (ADA). ACCESSIBILITY GUIDELINES WHICH EVER IS MORE ACCESSIBLE SHALL BE USED.
3. ALL WALKWAYS AND HANDICAP PARKING SPACES SHALL COMPLY WITH THE MAAB AND ADA ACCESSIBILITY GUIDELINES. IF FIELD CONDITIONS MAKE IT IMPOSSIBLE TO COMPLY WITH THESE GUIDELINES AND REGULATIONS, A WAIVER FROM THE MAAB WILL BE SOUGHT.
4. THE FOLLOWING CRITERIA SHALL CONTROL UNLESS OTHERWISE NOTED ON THE PLAN:
 - ALL DIMENSIONS ARE TO THE FACE OF CURB AT GUTTER LINE
 - ALL DIMENSIONS ARE TO CENTER OF PAVEMENT MARKINGS
 - ALL TIES TO PROPERTY LINES ARE PERPENDICULAR TO THE PROPERTY LINE UNLESS OTHERWISE NOTED.

GENERAL NOTES:

1. EXISTING CONDITIONS INFORMATION IS REPRODUCED FROM THE SITE PLAN PREPARED BY ANDERSON SURVEYS, INC. DATED APRIL 2, 2017.
2. FEMA FLOOD ZONES HAVE BEEN DIGITIZED BASED ON THE FEMA MAPS DATED 3-16-2018.
3. THE LOCATIONS OF UNDERGROUND UTILITIES SHOWN ARE BASED ON THE SURVEY REFERENCED ABOVE PRIOR TO THE START OF ANY EXCAVATION. THE CONTRACTOR SHALL NOTIFY DUGSAFE AND THE PROPER LOCAL AUTHORITIES OR RESPECTIVE UTILITY COMPANIES TO CONFIRM THE LOCATION OF ALL EXISTING UTILITIES BEFORE ANY EXCAVATION.
4. THE CONTRACTOR SHALL THOROUGHLY FAMILIARIZE THEMSELVES WITH ALL CONSTRUCTION DOCUMENTS, SPECIFICATIONS AND SITE CONDITIONS PRIOR TO BIDDING AND PRIOR TO CONSTRUCTION.
5. ANY DISCREPANCIES BETWEEN DRAWINGS, SPECIFICATIONS, AND SITE CONDITIONS SHALL BE REPORTED IMMEDIATELY TO THE OWNER'S REPRESENTATIVE FOR CLARIFICATION AND RESOLUTION PRIOR TO BIDDING OR CONSTRUCTION.
6. SCREENED IMAGES SHOW EXISTING CONDITIONS. WHERE EXISTING CONDITIONS ARE UNDER OR ARE REMOVED, ABANDONED AND/OR CAPPED OR DEMOLISHED AS REQUIRED.
7. THE CONTRACTOR IS RESPONSIBLE FOR ANY DAMAGE TO EXISTING CONDITIONS TO REMAIN THAT ARE NOT IDENTIFIED ON THIS PLAN.
8. ALL ITEMS TO BE REMOVED THAT ARE NOT STOCKPILED FOR LATER REUSE ON THE PROJECT OR DELIVERED TO THE OWNER SHALL BE LEGALLY DISPOSED OF BY THE CONTRACTOR.
9. THE CONTRACTOR SHALL COORDINATE ALL ADJUSTMENT OR ABANDONMENT OF UTILITIES WITH THE RESPECTIVE UTILITY COMPANY.

PROJECT INFORMATION

OWNER: HUDSON 62 REALTY, LLC
 OWNER ADDRESS: 440 BEDFORD STREET, LEXINGTON, MA 01824
 OWNER PHONE: (781) 863-8500
 PROJECT ADDRESS: 155 PORTER STREET, EAST BOSTON, MA

WARD: 01
 PARCEL: 039298000, 03927000 & 03928000
 PARCEL ACCT #: 1194282000
 BWSC METER #:

2% ANNUAL CHANCE OF FLOOD HAZARD

REMOVE AND REPLACE SIDEWALK 152' L.F. FRANKFORT STREET (LISTED AS PUBLIC - 50' WIDE L=433')

REPLACE ADA CURB-CUT IN KIND

LAYOUT AND MATERIALS LEGEND

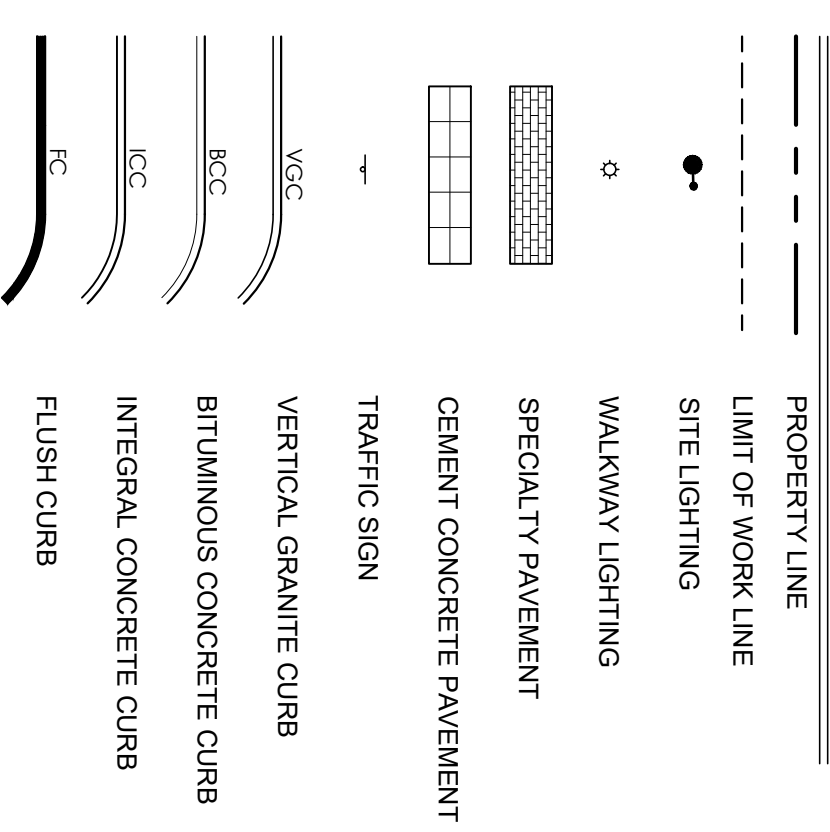

FOR BWSC USE ONLY

<p>ISSUED FOR CONSTRUCTION DECEMBER 8, 2017</p> <p>LAYOUT AND MATERIALS PLAN</p> <p>BWSC SITE PLAN #17410</p>		<p>REV.:</p> <p>6: 09-17-2019 BPDA COMMENTS</p> <p>7: 11-26-2019 BPDA COMMENTS</p> <p>8: 01-02-2020 BPDA COMMENTS</p> <p>9: 11-20-2020 BPDA COMMENTS</p> <p>10: 07-27-2021 NOI COMMENTS</p> <p>11: 10-20-2021 FEMA / LSCSF LINE</p>	<p>PROJECT:</p> <p>HOTEL REDEVELOPMENT 155 PORTER STREET, EAST BOSTON, MA</p> <p>CLIENT / APPLICANT:</p> <p>HUDSON 62 REALTY LLC 440 BEDFORD ST, LEXINGTON, MA 01824</p>	<p>CIVIL ENGINEER:</p> <p>PVI Site Design, LLC Civil Engineering - Land Entitlements Master Planning - Project Management 339-206-1030</p>
		<p>SCALE: 1" = 200'</p> <p>JOB NO: 003-002</p> <p>FILE: 003-003-G4mp</p> <p>DRAWN: TP</p> <p>CHECKED: TP</p> <p>SHEET NO: C101</p>		

SEWER FLOW CALCULATIONS:

SEWER DESIGN FLOWS BASED ON 310 CWR 15

EXISTING USE:	INDUSTRIAL BUILDING (540 PEOPLE)
UNIT FLOW:	15 GPD / PERSON
EXISTING FLOW:	8,100 GPD
PROPOSED USE:	120 ROOM HOTEL + 130 SEAT RESTAURANT
UNIT FLOW:	110 GPD PER ROOM 35 GPD PER SEAT
HOTEL FLOW:	13,590 GPD
RESTAURANT FLOW:	4,550 GPD
TOTAL NEW FLOW:	18,080 GPD
NET CHANGE:	+9,980 GPD (SEWER FLOW INCREASE)
GREASE TRAP SIZING:	15 GAL PER SEAT
MIN. SIZE:	1,950 GAL. → 2,000 GAL TRAP PROPOSED.

DRAINAGE CALCULATIONS SUMMARY

(FULL DRAINAGE CALCULATIONS WERE PREPARED USING HYDROCAD V10)

1. STORM EVALUATION	41,855 SF
TOTAL IMPERVIOUS AREA:	3,486 CF
1. STORM VOLUME:	
RECHARGE VOLUME:	
CHAMBERS:	45.4 CU FT PER STORM/TECH
VOL. / CHAMBER AT 27" FULL:	45.4 X 64 = 2,906 CU FT
STONE:	64 CHAMBERS:
PERMITS:	45.4 X 30.5 X 3.3' = 4,590 CU FT
LESS CHAMBERS:	45.4 X 30.5 X 3.3' = 4,590 CU FT
30% Voids:	3,474 X 0.3 = 1,102 CU FT
TOTAL:	2,906 + 1,102 = 4,008 CU FT
4,008 > 3,486 = OK	

INSPECTION SIGN-OFF SCHEDULE

ITEM NO.	DESCRIPTION OF SERVICE	QTY.	BWSC INSPECTOR DATE	COMMENTS
1	SANITARY PIPE INSTALLATION	68'		
2	SANITARY MANHOLE INSTALLATION	1		
3	SANITARY CHIMNEY CONNECTION	1		
4	REMOVE SEWER SERVICE	1		
5	GREASE TRAP INSTALLATION	1		
6	VIDEO NEW SANITARY PIPES	1		
7	OUTLET CONTROL STRUCTURE (OCSI)	1		
8	DRAINAGE PIPE INSTALLATION	320'		
9	DYE TEST SEWER	1		
10	DRAINAGE CHIMNEY CONNECTION	1		
11	POINT DUMP PLACQUE INSTALLATION	6		
12	VIDEO NEW DRAIN PIPES	1		
13	UNDERGROUND RECHARGE SYSTEM	1		
14	DYE TEST NEW DRAINAGE SYSTEM	1		
15	FIELD CONNECTION AT MAIN	1		
16	6" FIRE SERVICE INSTALLATION	1		
17	4" DOMESTIC SERVICE INSTALLATION	1		
18	BACKFLOW CONNECTION	1		
19	NEW 2" METER INSTALLATION	1		
20	TRENCH DRAIN	1		
21	DRAIN MANHOLE	1		
22	DRAIN MANHOLE #2	1		
23	DRAIN MANHOLE #3	1		
24	DRAIN MANHOLE #4	1		
25	DRAIN MANHOLE #5 (DRAINAGE MANHOLE)	1		
26	DRAIN MANHOLE #6 (SLUMP AND HOOD)	1		
27	REMOVE 4" FIRE SERVICE	1		
28	REMOVE 4" FIRE SERVICE	1		
29	REMOVE 4" FIRE SERVICE	1		
30	SHALLOW CATCH BASIN PCB1	1		
31	SHALLOW CATCH BASIN PCB2	1		
32	SHALLOW CATCH BASIN PCB3	1		
33	TYP CATCH BASIN WITH OIL TRAP PCB4	1		
34	TYP CATCH BASIN WITH OIL TRAP PCB5	1		

GRADING AND UTILITY NOTES:

- EXISTING CONDITIONS INFORMATION IS REPRODUCED FROM THE 'SITE PLAN' PREPARED BY ANDERSON SURVEYS, INC. DATED APRIL 2, 2017.
- ALL ELEVATIONS REFER TO BOSTON CITY BASE.
- WHERE PROPOSED GRADES MEET EXISTING GRADES, CONTRACTOR SHALL BLEND GRADES TO PROVIDE A SMOOTH TRANSITION BETWEEN EXISTING AND NEW WORK. HOUDING AT TRANSITION AREAS WILL NOT BE ALLOWED.
- ENSURE ALL EXISTING (TO REMAIN) AND PROPOSED MANHOLE COVERS PROPERLY IDENTIFY UTILITY SERVICES.
- CONTRACTOR SHALL VERIFY EXISTING GRADES AND NOTIFY OWNER'S REPRESENTATIVE OF ANY DISCREPANCIES.
- CONTRACTOR SHALL ADJUST ALL UTILITY ELEMENTS MEANT TO BE FLUSH WITH GRADE (CATCH-OUTS, UTILITY MANHOLES, ETC) THAT IS AFFECTED BY SITE WORK OR GRADE CHANGES, WHETHER SPECIFICALLY NOTICED ON PLANS OR NOT.
- ALL CONSTRUCTION TO BE DONE IN ACCORDANCE WITH BOSTON WATER AND SEWER STANDARDS.
- WHERE EXISTING UTILITIES ARE FOUND TO CONFLICT WITH THE PROPOSED WORK, THE LOCATION, ELEVATION AND SIZE OF THE UTILITY SHALL BE ACCURATELY DETERMINED BY THE CONTRACTOR AND THE ENGINEER PRIOR TO CONSTRUCTION. THE CONTRACTOR SHALL BE RESPONSIBLE FOR OBTAINING THE NECESSARY PERMITS AND RESETTING ALL FRAMES, GRATES, AND BOXES TO THE PROPOSED FINISHED GRADE.
- PROTECT AND MAINTAIN EXISTING ON-SITE DRAINAGE STRUCTURES AND PIPES UNLESS OTHERWISE NOTED.
- DRAINAGE PIPES SHALL BE SDR 35 UNLESS OTHERWISE NOTED.
- ALL SEWER PIPES 4" OR LARGER SHALL BE CLASS 56, ZINC COATED DUCTILE IRON.
- ALL SOILS REMOVED FROM THE SITE SHALL BE DISPOSED OF BY THE CONTRACTOR AT CONTRACTOR'S EXPENSE. SOILS MAY BE CONTAMINATED. CONTRACTOR SHALL CONSULT WITH OWNER'S LICENSED SITE PROFESSIONAL (LSP) PRIOR TO ANY EXCAVATION TO CONFIRM EXCAVATION AND DISPOSAL REQUIREMENTS.
- FEMA FLOOD ZONES HAVE BEEN DIGITIZED BASED ON THE FEMA MAPS DATED 3-16-2016.

TV INSPECTION OF SEWERS & DRAINS

- THE CONTRACTOR SHALL FURNISH ALL EQUIPMENT, LABOR, MATERIALS, AND SUPERVISION AS REQUIRED TO INSPECT THE INTERIOR OF ALL SEWERS AND DRAINS. PROVIDE VIDEO RECORDINGS WITH VOICE DESCRIPTIONS AS WELL AS FULL INSPECTION REPORTS, AND ALL OTHER APPROPRIATE WORK, WITHIN THE LIMITS SHOWN ON THE DRAWINGS, AS DIRECTED BY THE ENGINEER AND AS SPECIFIED IN THE BOSTON WATER & SEWER DEVS) SPECIFICATION TELEVISION INSPECTION OF SEWERS AND DRAINS AS LATEST EDITION.
- HTP://WWW.MANAGE-CR-REGULATIONS.CONSTRUCTION.SPEC.CONSTRUCTION.SPECS
- PIPES SHALL NOT BE INSPECTED UNTIL COMPLETELY CLEANED IN ACCORDANCE WITH THE SPECIFICATION NOTED IN #1 AND TO THE SATISFACTION OF THE BWSC INSPECTOR AND OWNER'S REPRESENTATIVE.

ORLEANS STREET
(LISTED AS PUBLIC - 50' WIDE L-4814)
ADJUST EXISTING MONITORING WELLS IN THIS AREA TO FG OR AS DIRECTED BY OWNER'S REPRESENTATIVE.

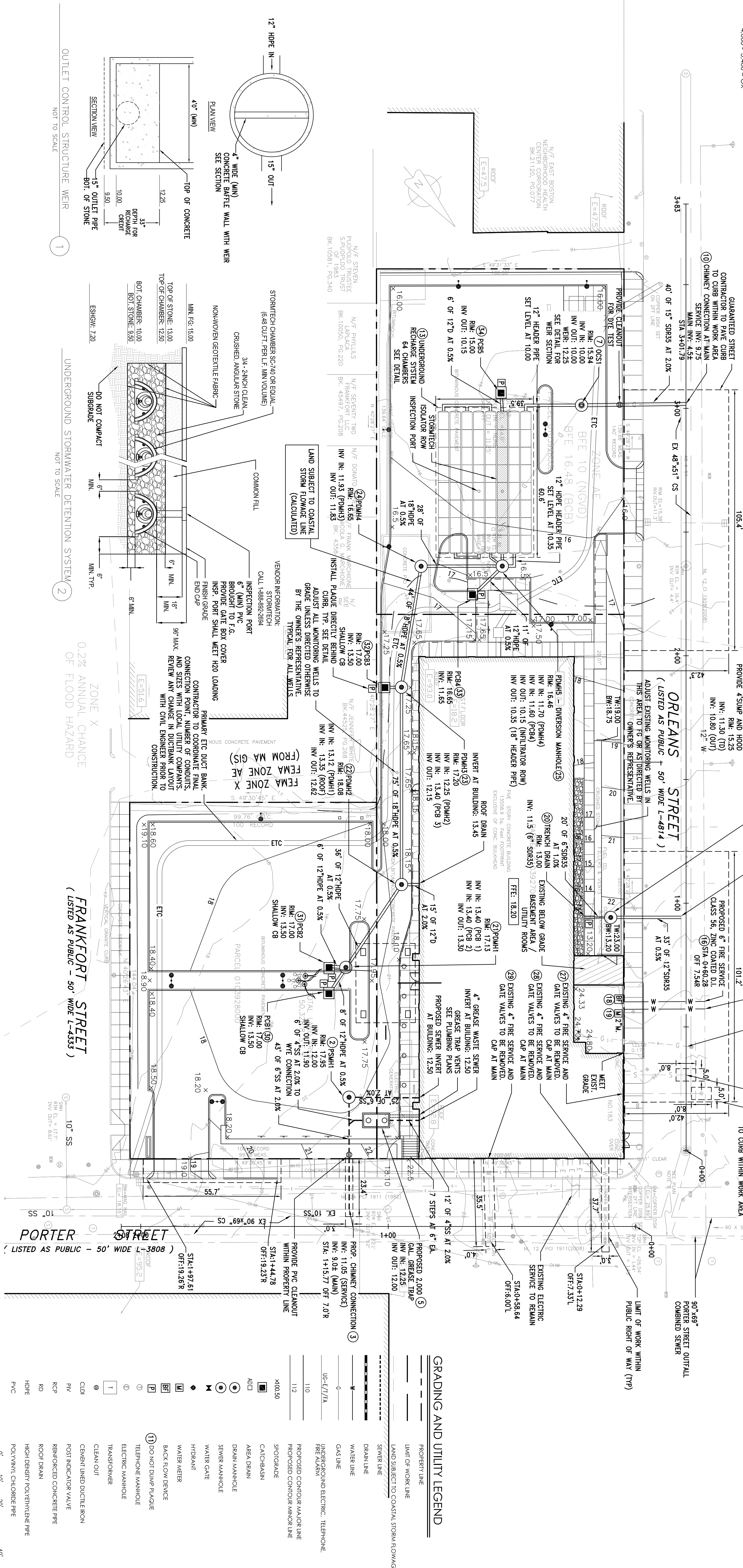

GRADING AND UTILITY LEGEND

PROPERTY LINE	---
LIMIT OF WORK LINE	---
LAND SUBJECT TO COASTAL STORM FLOWAGE	---
SEWER LINE	---
DRAIN LINE	---
WATER LINE	---
GAS LINE	---
UNDERGROUND ELECTRIC, TELEPHONE, FIRE ALARM	---
PROPOSED MAJOR LINE	---
PROPOSED MINOR LINE	---
SPOT GRADE	---
CATCH BASIN	---
AREA DRAIN	---
DRAIN MANHOLE	---
SEWER MANHOLE	---
WATER GATE	---
HYDRANT	---
WATER METER	---
BACKFLOW DEVICE	---
POINT DUMP PLACQUE	---
TELEPHONE MANHOLE	---
ELECTRIC MANHOLE	---
TRANSFORMER	---
CLEAN OUT	---
CEMENT LINED DUCTILE IRON	---
POST INDICATOR VALVE	---
RINFORCED CONCRETE PIPE	---
ROOF DRAIN	---
HIGH DENSITY POLYETHYLENE PIPE	---
POLYBUTYLENE CHLORIDE PIPE	---

FOR BWSC USE ONLY
PARCEL #: 0103928000
PARCEL #: 0103927000
PARCEL #: 0103928000

<p>ISSUED FOR CONSTRUCTION DECEMBER 8, 2017</p> <p>GRADING AND UTILITY PLAN</p> <p>BWSC SITE PLAN #17410</p>	<p>SEAL:</p>	<p>REV:</p> <ul style="list-style-type: none"> 6: 09-17-2019 BPDA COMMENTS 7: 11-26-2019 BPDA COMMENTS 8: 01-02-2020 BPDA COMMENTS 9: 11-20-2020 BPDA COMMENTS 10: 07-27-2021 NOI COMMENTS 11: 10-20-2021 FEMA / LSCSF LINE 	<p>PROJECT:</p> <p>HOTEL REDEVELOPMENT 155 PORTER STREET, EAST BOSTON, MA</p> <p>CLIENT / APPLICANT: HUDSON 62 REALTY LLC 440 BEDFORD ST, LEXINGTON, MA 01824</p>	<p>CIVIL ENGINEER:</p> <p>PVI Site Design, LLC Civil Engineering - Land Entitlements Master Planning - Project Management 339-206-1030</p>
		<p>SCALE: 1"=20'</p> <p>JOB NO: 003-003</p> <p>FILE: 003-003-06.dwg</p> <p>DRAWN: TJP</p> <p>CHECKED: TJP</p> <p>SHEET NO: C102</p>		

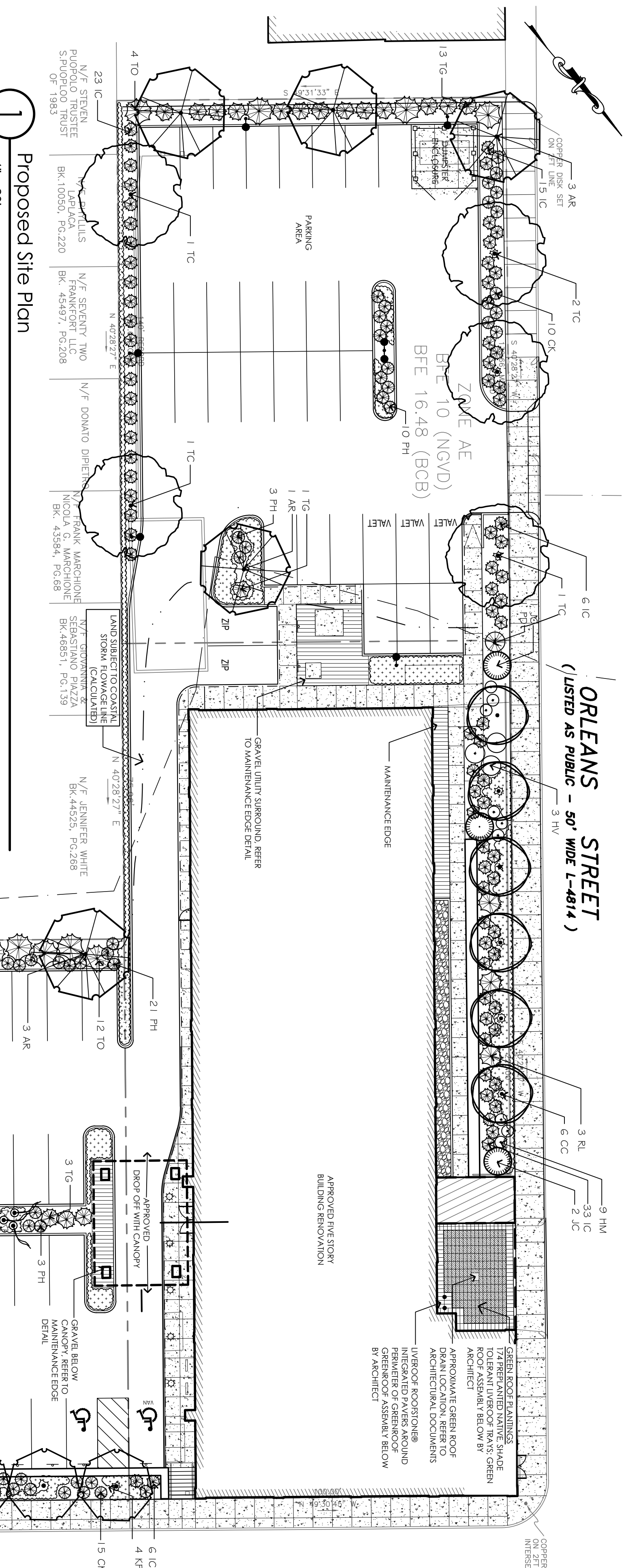

1
Proposed Site Plan
1" = 20'

NOTES

- CONTRACTOR SHALL BEGIN MAINTENANCE IMMEDIATELY AFTER PLANTING AND WILL CONTINUE UNTIL FINAL WRITTEN ACCEPTANCE OF PLANT MATERIAL.
- WHERE THE SITE IS NOT IRRIGATED, THE CONTRACTOR SHALL MAINTAIN THE SITE FOR A MINIMUM OF 2 YEARS TO ALLOW MATERIALS THROUGH ESTABLISHMENT AS SPECIFIED IN THE CONTRACT DOCUMENTS.
- OWNERS REPRESENTATIVE TO FLAG ALL TREES TO BE TRANSPLANTED PRIOR TO CONSTRUCTION START.
- CONTRACTOR SHALL VERIFY ALL TREE REMOVALS AND/OR TRANSPLANTS WITH OWNERS REPRESENTATIVE PRIOR TO CONSTRUCTION START.
- CONTRACTOR SHALL MAINTAIN POSITIVE DRAINAGE AWAY FROM ALL BUILDING FOUNDATIONS, STRUCTURES, AND PLANTING BEDS.
- MAXIMUM SLOPE WITHIN DISTURBED AREAS SHALL NOT EXCEED 3:1 UNLESS OTHERWISE NOTED.
- THE LANDSCAPE CONTRACTOR SHALL SUPPLY ALL PLANT MATERIALS IN QUANTITIES SUFFICIENT TO COMPLETE ALL PLANTINGS SHOWN ON THIS DRAWING.
- ALL MATERIALS SHALL CONFORM TO THE GUIDELINES ESTABLISHED BY THE AMERICAN NURSERY AND LANDSCAPE ASSOCIATION.
- ALL PLANTS SHALL BEAR THE SAME RELATIONSHIP TO FINISH GRADE AS TO ORIGINAL GRADES BEFORE DIGGING.
- ALL PLANTS TO BE BALLED IN BURLAP OR CONTAINERIZED.
- MULCH FOR PLANTED AREAS TO BE AGED PINE BARK, PARTIALLY DECOMPOSED, DARK BROWN IN COLOR AND FREE OF WOOD CHIPS THICKER THAN 1/4 INCH.
- SAFE USE OF MULCH IS REGULATED THROUGH 497 CMR 1.00, SECTION 10.13.10.4. THE REGULATION PROHIBITS THE NEW APPLICATION OF MULCH WITHIN 18" AROUND COMBUSTIBLE EXTERIOR OF BUILDINGS, SUCH AS WOOD OR VINYL, BUT NOT BRICK OR CONCRETE. THE MAINTENANCE EDGE BETWEEN PLANTING BEDS SHALL BE 18" FROM THE PLANTING BEDS WITHIN 18" OF A COMBUSTIBLE BUILDING SURFACE.
- ALL PLANT BEDS SHALL BE EDGED IN 4 INCH COMMERCIAL GRADE BLACK STEEL LANDSCAPE EDGING.
- PLANTING SOIL MIX: LOAM HORIZONTALY INCORPORATED WITH ROTATED MANURE PROPORTIONED 5 C.Y. TO 1 C.Y. OR EQUIVALENT. FERTILIZER ADDED PER RECOMMENDED RATES OF SOILS ANALYSIS.
- THE LANDSCAPE CONTRACTOR SHALL GUARANTEE ALL PLANT MATERIALS FOR ONE (1) FULL YEAR FROM DATE OF ACCEPTANCE.
- ALL PLANT MATERIALS ARE SUBJECT TO THE APPROVAL OF THE OWNERS REPRESENTATIVE, AT THE NURSERY, AND AT THE SITE.
- ALL AREAS OF THE SITE WHICH HAVE BEEN DISTURBED AND NOT OTHERWISE DEVELOPED SHALL BE TOPMADE AND SEEDED WITH A MINIMUM DEPTH OF 8" DEPTH TO SOIL.
- PLANT SPECIES AS INDICATED IN THE PLANT LIST ARE SUGGESTIONS ONLY. FINAL SELECTION OF SPECIES SHALL OCCUR AT THE TIME OF FINAL PACKAGE. DEPENDENCY ON AVAILABILITY OF SPECIES SHALL BE THE RESPONSIBILITY OF THE CONTRACTOR. CHANGE WITHOUT APPROVAL OF OWNERS REPRESENTATIVE.
- PRE-PLANTED LIVE ROOF TRAYS WITH SHADE-TOLERANT NATIVE SPECIES WILL BE A CUSTOM ORDER. CONTRACTOR SHALL ALLOW A MINIMUM 12 WEEK LEAD TIME FROM TO SHIPPING.
- NATIVE PLANT SELECTIONS MAY BE DIFFICULT TO SOURCE. NURSERY SHOULD BE CONTACTED AS SOON AS POSSIBLE TO CONFIRM AVAILABILITY. POTENTIAL SOURCES INCLUDE: BUT NOT LIMITED TO:
 - NASAKI FARM, WHATELY, MA
 - NEMENGLAND WILD ORG/INSTIT/NASAKI FARM
 - NATIVE FARFIELD, CT. NATIVEPLANTNURSERY.COM
 - EARHINGTONS NATURE PLANTS, WOODBURY, CT. EARHINGTONS.NATURE.COM

LEGEND

- PROPOSED SITE LIGHT Poles
- CEMENT CONCRETE PAVEMENT
- MAINTENANCE EDGE
- GROUND COVER AND PERENNIAL PLANTINGS
- SHRUB PLANTING
- UPRIGHT TREE SPECIES CAROLINANA
- UNDERWIRE TREE SPECIES OSTRYA VIRGINIANA
- SHADE TREE SPECIES NYSSA SYLVATICA
- PARKING LOT TREE SPECIES ACER RUBRUM

GREEN ROOF PLANTINGS

- GREEN ROOF SHALL BE PRE-PLANTED THROUGH STANDARD LIVING ROOF SYSTEMS:
 - CLEVELAND, ST. NUNICA W/4448 USA, 1-616-842-1392
 - SALES@LIVEROOF.COM, HTTPS://LIVEROOF.COM
- PLANT SPECIES SHALL BE SELECTED FOR LOCAL ZONE, PRODUCE TOLERANCE, AND SHADE TOLERANCE. INVASIVE PLANT SPECIES SHALL NOT BE USED.
- MODULE INFORMATION:
 - SOIL DEPTH: APPROXIMATELY 4 1/2"
 - MODULE SIZE (PLASTIC): 1' X 2' X 3 1/2"
 - Saturated weight: APPROXIMATELY 29 LBS PER SQUARE FOOT
 - FOOT WEIGHT: APPROXIMATELY 20 POUNDS PER SQUARE FOOT
 - SOIL DRY WEIGHTS MAY VARY REGIONALLY DEPENDING UPON THE LOCALLY SOURCED AGGREGATES.
 - CONCRETE DRY WEIGHTS WITH LOCAL LIVEROOF LICENSED ROOF ASSEMBLY FROM MODULES WATERPROOFING, INSULATION, FFCI SHALL BE SELECTED IN COORDINATION WITH THE PROJECT ARCHITECT

SUGGESTED PLANT SCHEDULE

SYMBOL	BOTANICAL NAME	COMMON NAME	QTY	SIZE	COMMENT
DECIDUOUS TREES					
AR	ACER RUBRUM	RED MAPLE	7	2-2 - 1/2" CAL	
KP	OSTRYA VIRGINIANA*	AMERICAN HOPHORNBEAM	4	2-2 - 1/2" CAL	
TC	NYSSA SYLVATICA*	SOUR GUM	9	2-2 - 1/2" CAL	
CC	CARPINUS CAROLINIANA*	AMERICAN HORNBEAM	6	2-2 - 1/2" CAL	
SHRUBS					
HM	HAMAMIDIS VIRGINIANA	WITCHHAZEL	3	4.5" HT, HEAVY	
IC	LEIDY CLABRA	INCENSED JUNEBERRY	96	3 GALLON	
IC	JUNIPERUS VIRGINIANA*	JUNIBERRY	7	5-GI (H&B)	
RL	LEUCODIUM RALPHENSE*	CONSISTAL DOGWOOD	3	5 GALLON	
TO	TRIALIX CANADENSIS*	TEA	41	1.5-2.1" H&B	
TO	TRIALIX OCCIDENTALIS*	ARBORVITAE	116	6-7" H&B	
ORNAMENTAL GRASSES					
CK	RIDDERIA FLUIDA*	BLACK-ETED SUSAN	25	1 GALLON	
FG	SIROPHANTHUM AUGUSTIFOLIUM*	NARROW BLUE-ETED GRASS	42	2 GALLON	
FD	SONGHASTRUM NUTANS*	INDIAN GRASS	1	1 GALLON	
PH	MILLETNERGIA CAPILLARIS*	PINK WULFY GRASS	43	2 GALLON	
PERENNIALS AND GROUND COVER					
ARCT	ARCTOSTAPHYLOS UVA-URSI*	BLACKBERRY	100	1 GALLON	
ACH	ACHILLEA SP.*	WILD YACHT	100	1 GALLON	
AS	ASARUM CANADENSE*	WILD GINGER	100	1 GALLON	
ED	EURYTHYMUS DIVARICATUS*	WILD WOOD AGTIR	100	1 GALLON	
GA	GALLIARIA ARGENTEA*	BLANLET FLOWER	100	1 GALLON	
IP	IPERISQUILA DIPHYLLA*	TYNDELLE	100	1 GALLON	
JUN	JUNIPERUS HORIZONTALIS*	CREEPING JUNIPER	100	1 GALLON	
KO	KOENIGIA HIBERNICA*	CANADA WATTLOR	100	1 GALLON	
MO	MOENCHYRIA TRILOBATA*	WILD BEEBACON	100	1 GALLON	
MO	MOENCHYRIA TRILOBATA*	WILD BEEBACON	100	1 GALLON	
MO	MOENCHYRIA TRILOBATA*	WILD BEEBACON	100	1 GALLON	
MO	MOENCHYRIA TRILOBATA*	WILD BEEBACON	100	1 GALLON	
MO	MOENCHYRIA TRILOBATA*	WILD BEEBACON	100	1 GALLON	
MO	MOENCHYRIA TRILOBATA*	WILD BEEBACON	100	1 GALLON	
MO	MOENCHYRIA TRILOBATA*	WILD BEEBACON	100	1 GALLON	
MO	MOENCHYRIA TRILOBATA*	WILD BEEBACON	100	1 GALLON	

* INDICATES DROUGHT TOLERANT SPECIES PER LOCAL NURSERY CATALOGS. EXTENSION SAVCS.

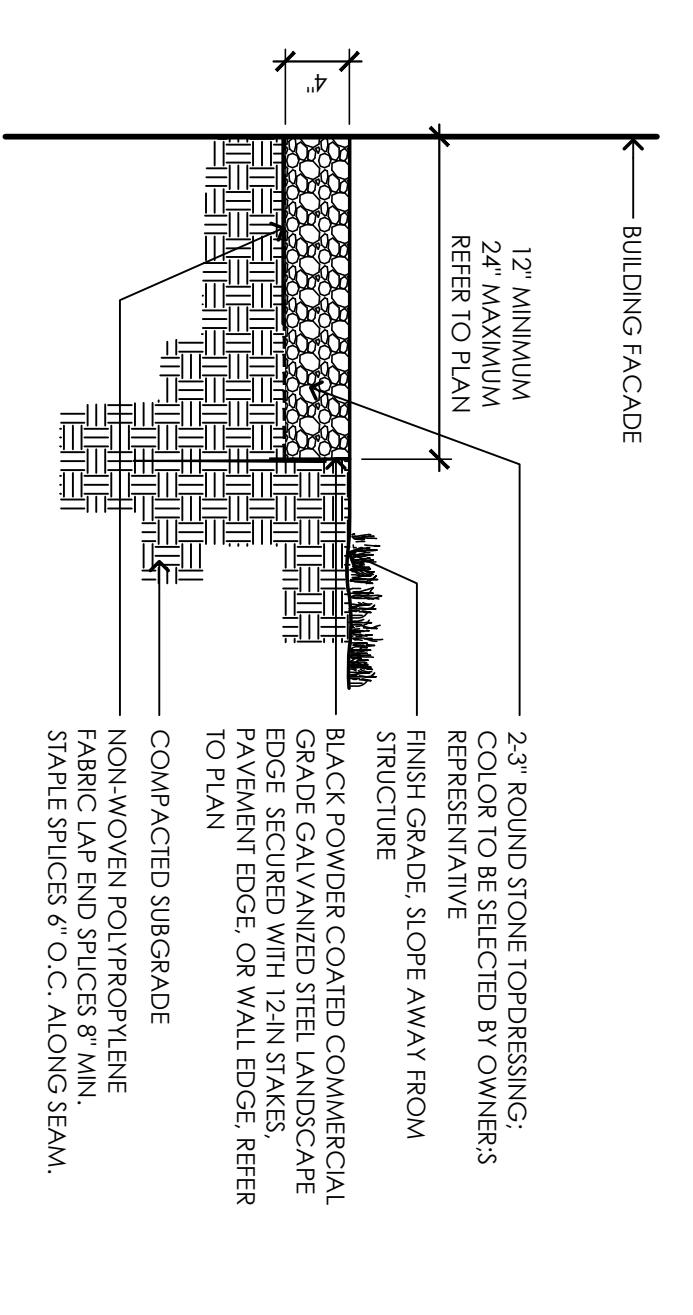

2
MAINTENANCE EDGE
NTS

NOTE: TREE SHALL BEAR SAME RELATIONSHIP TO FINISHED GRADE AS IT BORE TO NURSERY OR FIELD GRADE. TRUNK FLARE SHALL BE VISIBLE ABOVE SOIL.
 3" BARK MULCH IN SAUCER. KEEP 2" CLEAR OF TRUNK. EXTERIOR OF TREE PIT PLANT SAUCER. 4" CONTINUOUS HEIGHT SEED OR SOD AS NOTED ON PLANS.
 FINISH GRADE

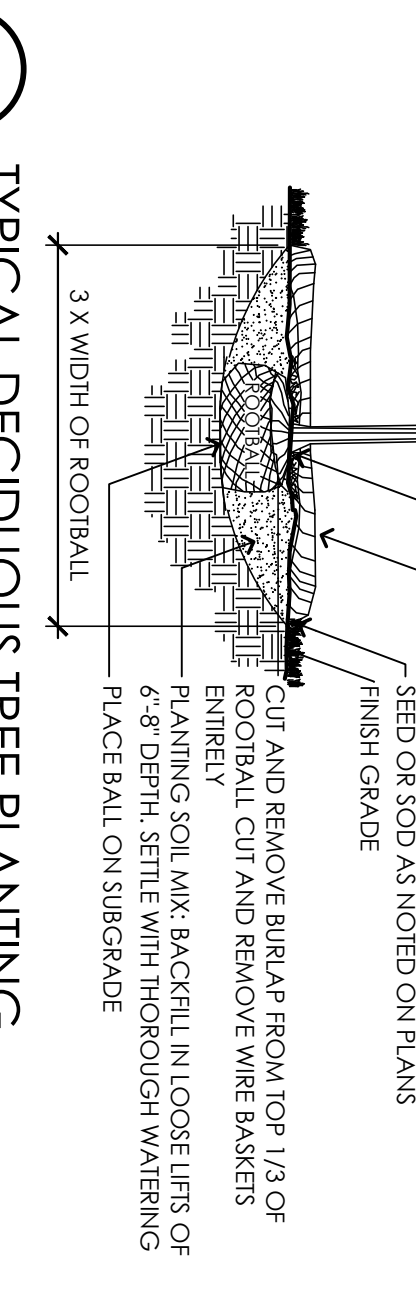

3
TYPICAL DECIDUOUS TREE PLANTING
NTS

WIRE AROUND TREE IN ENCASED REINFORCED HOSE. SECURE WIRE ENDS WITH WALKABLE CABLE CLAMP.
 PROVIDE GALVANIZED TURBULENCE ONE PER WIRE.
 PLANT SAUCER. 4" CONTINUOUS. NO SAUCER WHERE TREES OCCUR WARNING FLAG 18" ABOVE FINISH GRADE.
 SET ANGLE OF GUYS TO ENTER GROUND AT LIMIT OF BRANCH SPREAD.
 CUT AND REMOVE ALL BURLAP AND WIRE BASKETS FROM ROOT BALL.
 FINISH GRADE.
 PLANTING SOIL MIX: BACKFILL IN LOOSE LIFTS OF 6"-8" DEPTH. SETTLE WITH THOROUGH WATERING.
 PLACE ROOT BALL ON UNDISTURBED SOIL. IF SOIL HAS BEEN DISTURBED, PROVIDE COMPACTION TO MINIMIZE SETTLING.

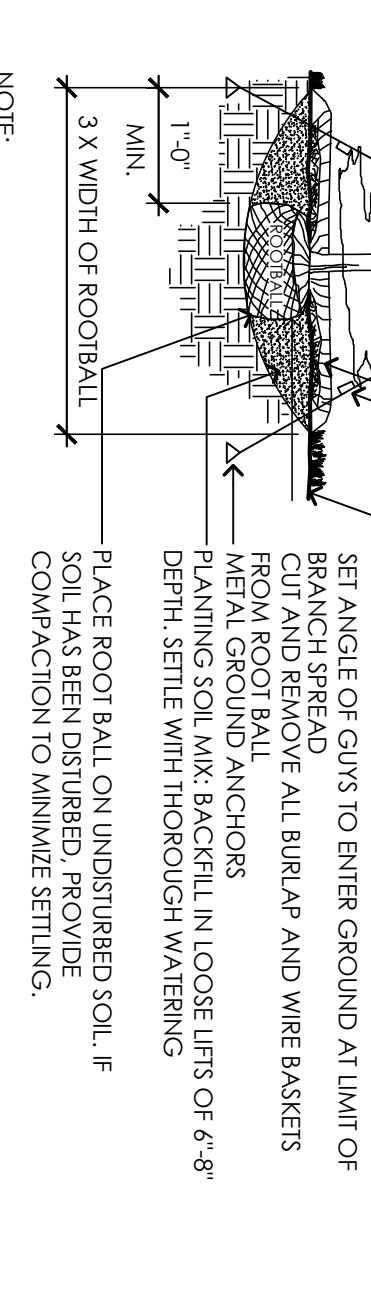

4
TYPICAL EVERGREEN TREE PLANTING
NTS

1. TREE SHALL BEAR SAME RELATIONSHIP TO FINISHED GRADE AS IT BORE TO NURSERY OR FIELD GRADE.
 2. INSTALL THREE GUYS PER TREE. EQUALLY SPACED AROUND BALL. ATTACH GUYS AT 2/3 HEIGHT OF TREE. USE DOUBLE STAND GALVANIZED STEEL WIRE.

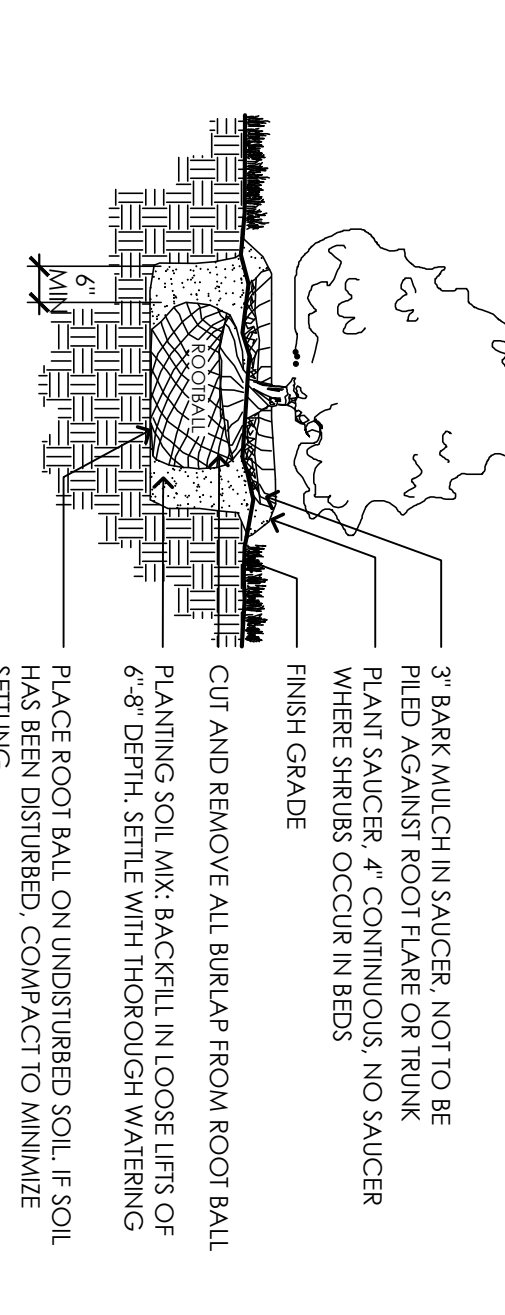

5
TYPICAL SHRUB PLANTING
NTS

1. SHRUB SHALL BEAR SAME RELATIONSHIP TO FINISHED GRADE AS IT BORE TO NURSERY OR FIELD GRADE.
 2. WHERE SHRUBS OCCUR IN GROUPINGS IN PLANT BEDS, PROVIDE 2 - FOOT DEEP CONTINUOUS LOAM BED.

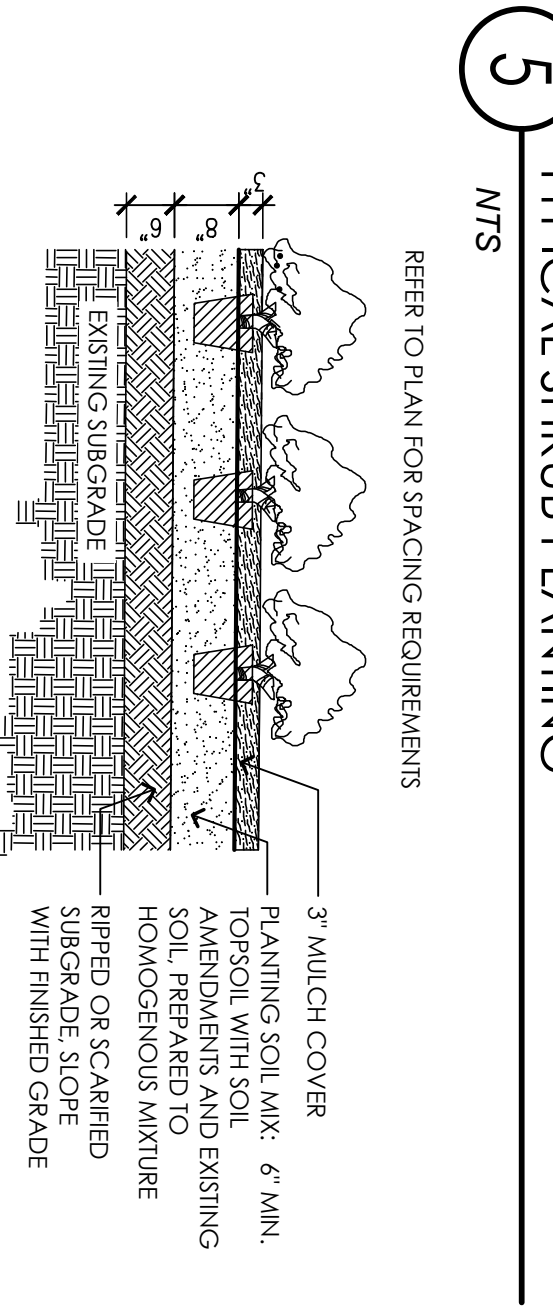

6
TYPICAL GROUND COVER PLANTING
NTS

REVISIONS:

REV:	1: 09-17-2019	BPDA COMMENTS
REV:	2: 11-26-2019	BPDA COMMENTS
REV:	3: 12-23-2019	BPDA COMMENTS
REV:	4: 01-02-2020	GREEN ROOF
REV:	5: 06-09-2021	NATIVE PLANTS
REV:	6: 10-20-2021	FEMA LINE

HOTEL REDEVELOPMENT
155 PORTER STREET, EAST BOSTON, MA

PROJECT: APPLICANT:
HUDSON 62 REALTY LLC
440 BEDFORD ST, LEXINGTON, MA 01824

LANDSCAPE ARCHITECT:
rb|la DESIGN
RBLA Design LLC
rbladesign.com
781.686.4486

100% CONSTRUCTION DOCUMENTS
DECEMBER 8, 2017

LANDSCAPE PLAN, NOTES,
DETAILS AND SCHEDULE

SCALE: AS NOTED

JOB NO: 1916

FILE: 1916-Land

DRAWN: RAB

CHECKED: RAB

SHEET NO: L101

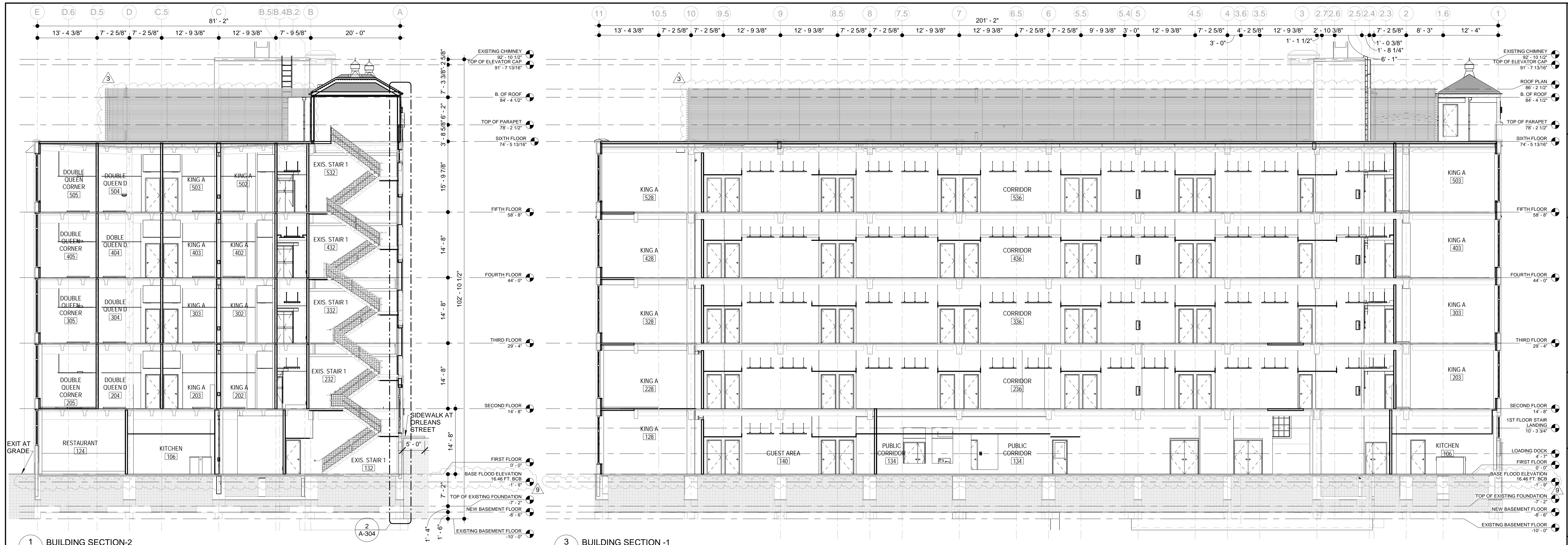

1 BUILDING SECTION-2
3/32" = 1'-0"
A-300

3 BUILDING SECTION -1
3/32" = 1'-0"
A-300

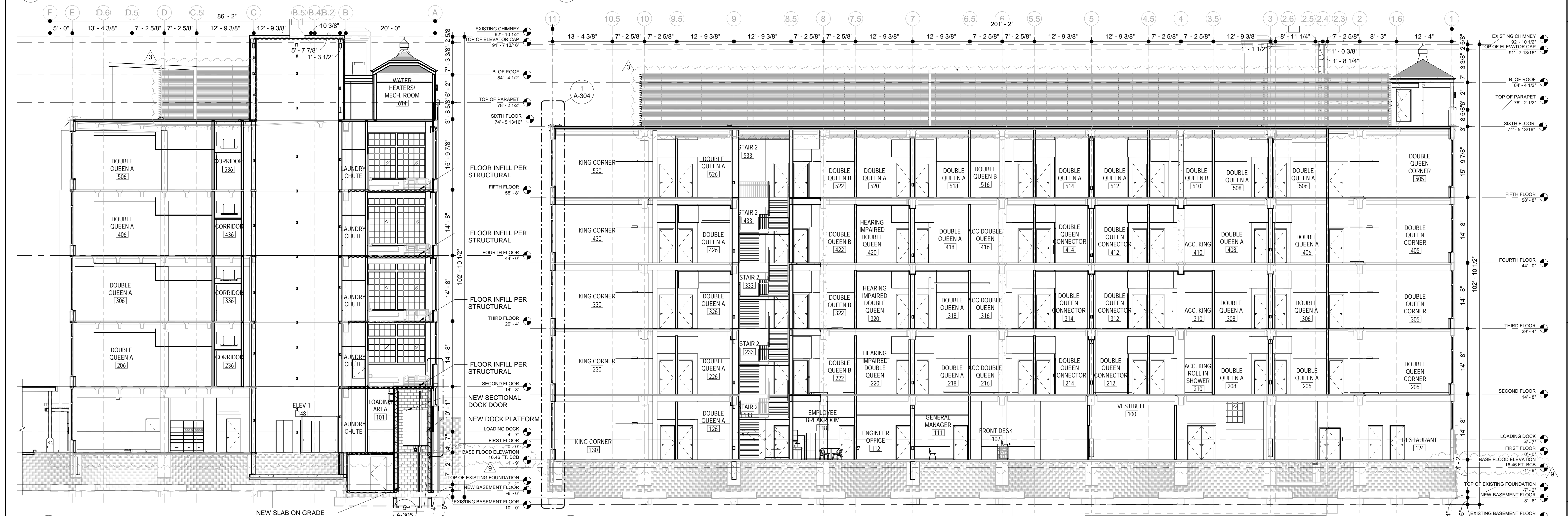

2 BUILDING SECTION -4
3/32" = 1'-0"
A-300

4 BUILDING SECTION -3
3/32" = 1'-0"
A-300

RUSSELL AND DAWSON INC.
ARCHITECTURE & ENGINEERING
1111 Main Street, East Hartford, CT 06108
TEL: (860) 282-1100 FAX: (860) 282-5272 EMAIL: info@rdai.com

PROJECT: CONVERSION TO CAMBRIA SUITES
175 ORLEANS STREET, BOSTON, MA 02128

FILE NO.: 16155.01
SCALE: 3/32" = 1'-0"
DATE: 09/29/2018
DRAWN BY: AKP
CHECKED BY: UKP

REVISIONS:

NO.	DESCRIPTION	DATE	BY
1	GENERAL REVISION	11/27/2019	UKP
2	GENERAL REVISION	10/12/2021	UKP
3	GENERAL REVISION	10/12/2021	UKP
9	GENERAL REVISION		

STAMP:

SHEET TITLE: BUILDING SECTIONS
SHEET NUMBER: A-300

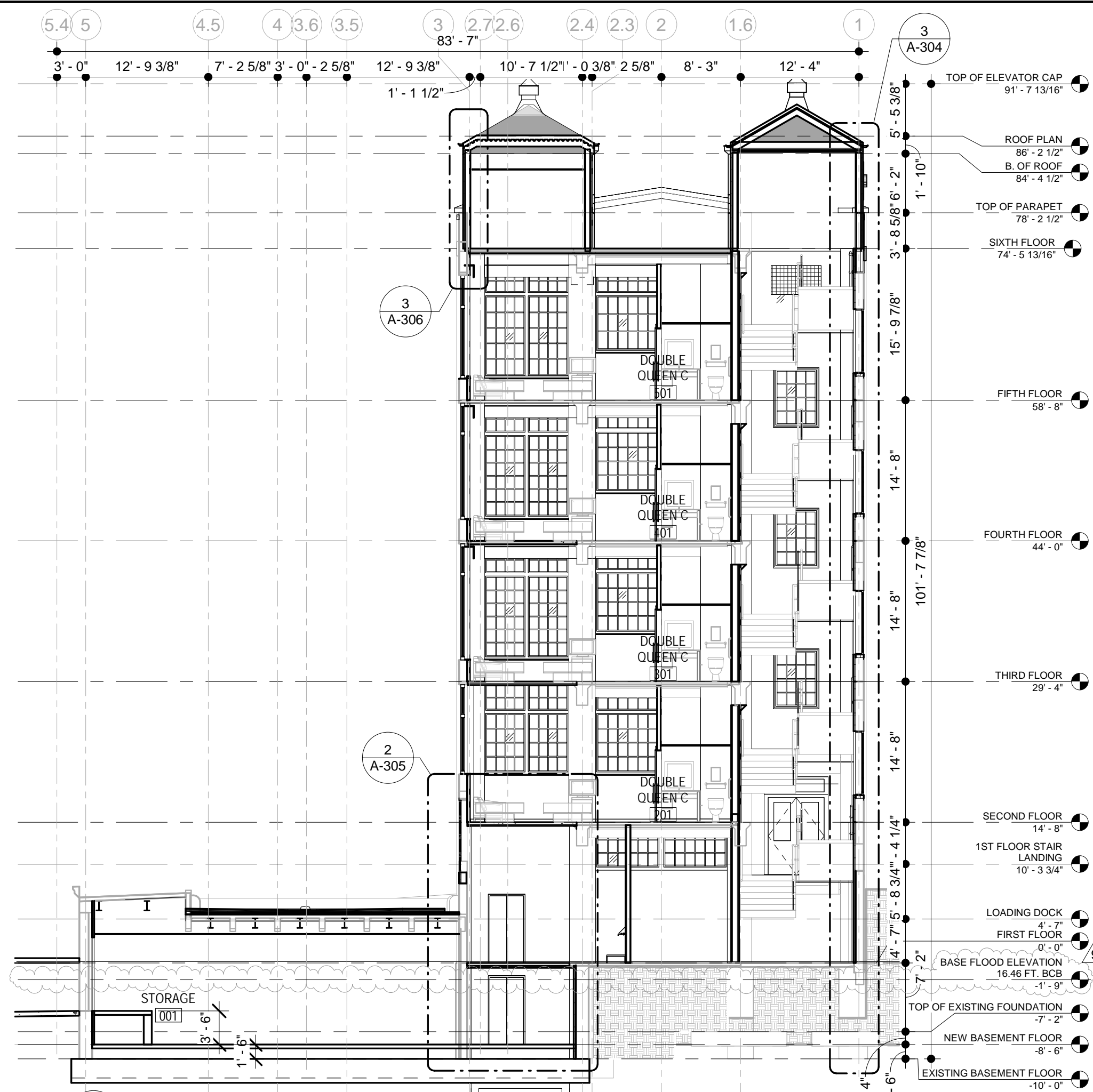

1 BUILDING SECTION
A-301 3/32" = 1'-0"

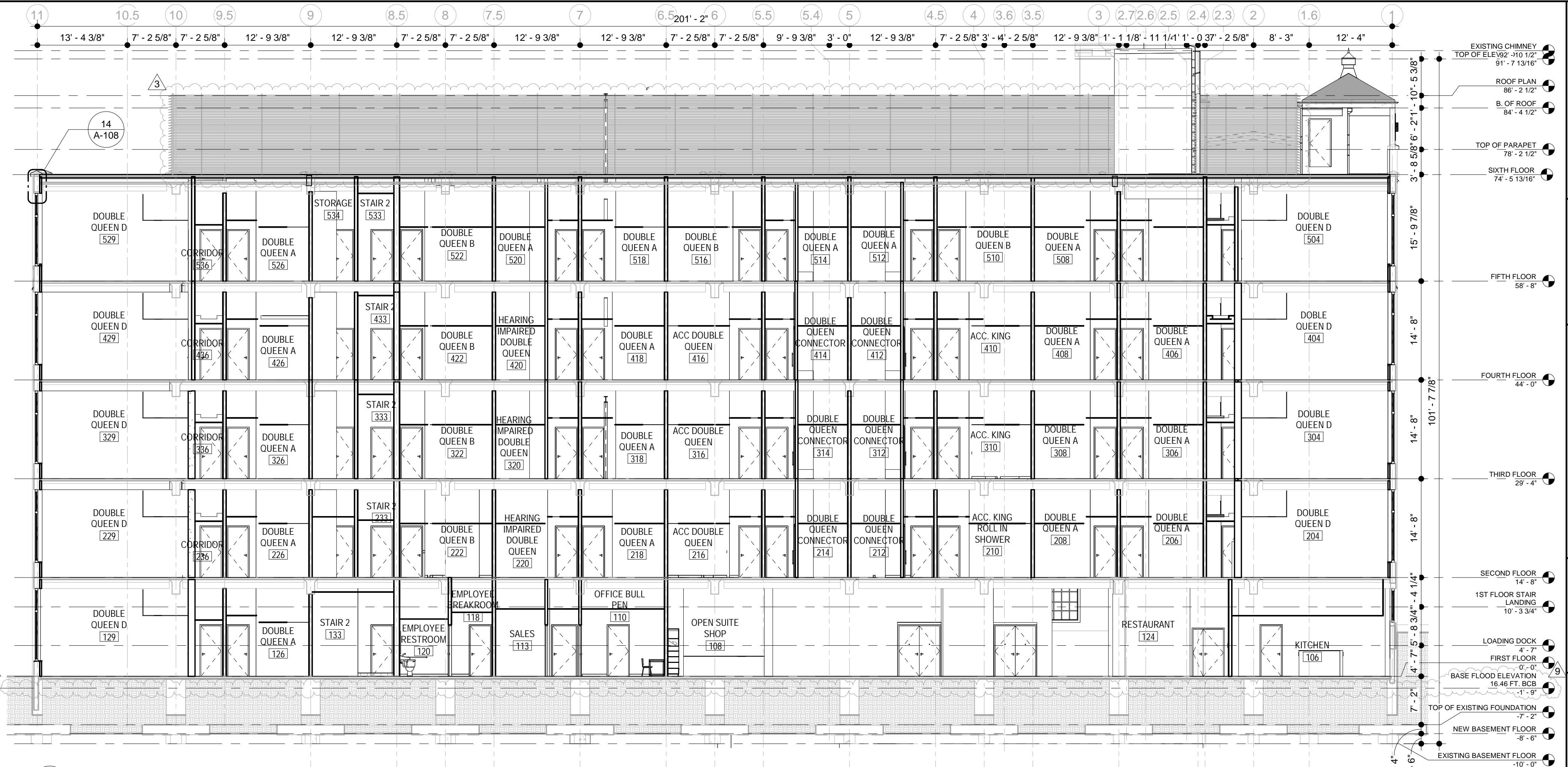

2 BUILDING SECTION
A-301 3/32" = 1'-0"

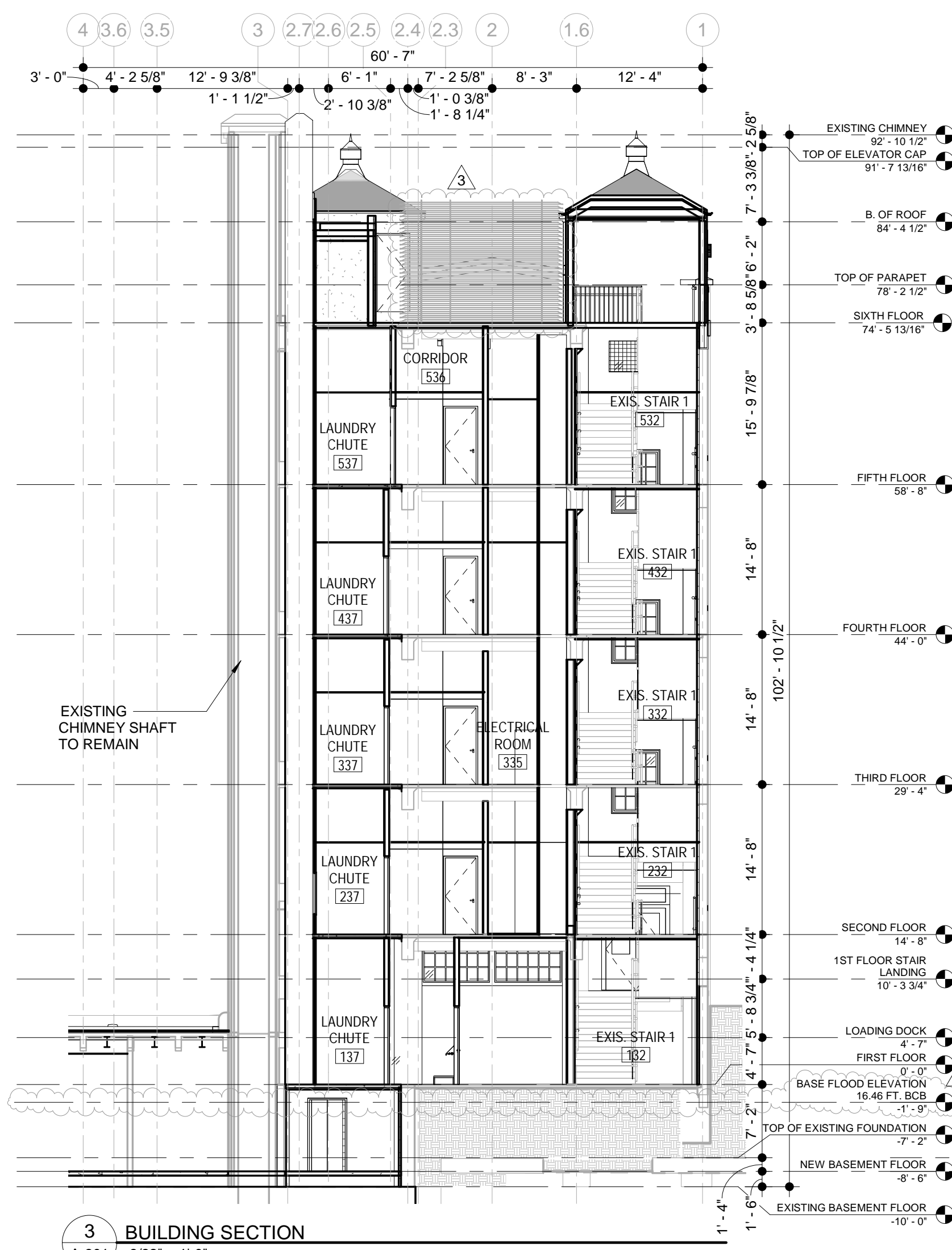

3 BUILDING SECTION
A-301 3/32" = 1'-0"

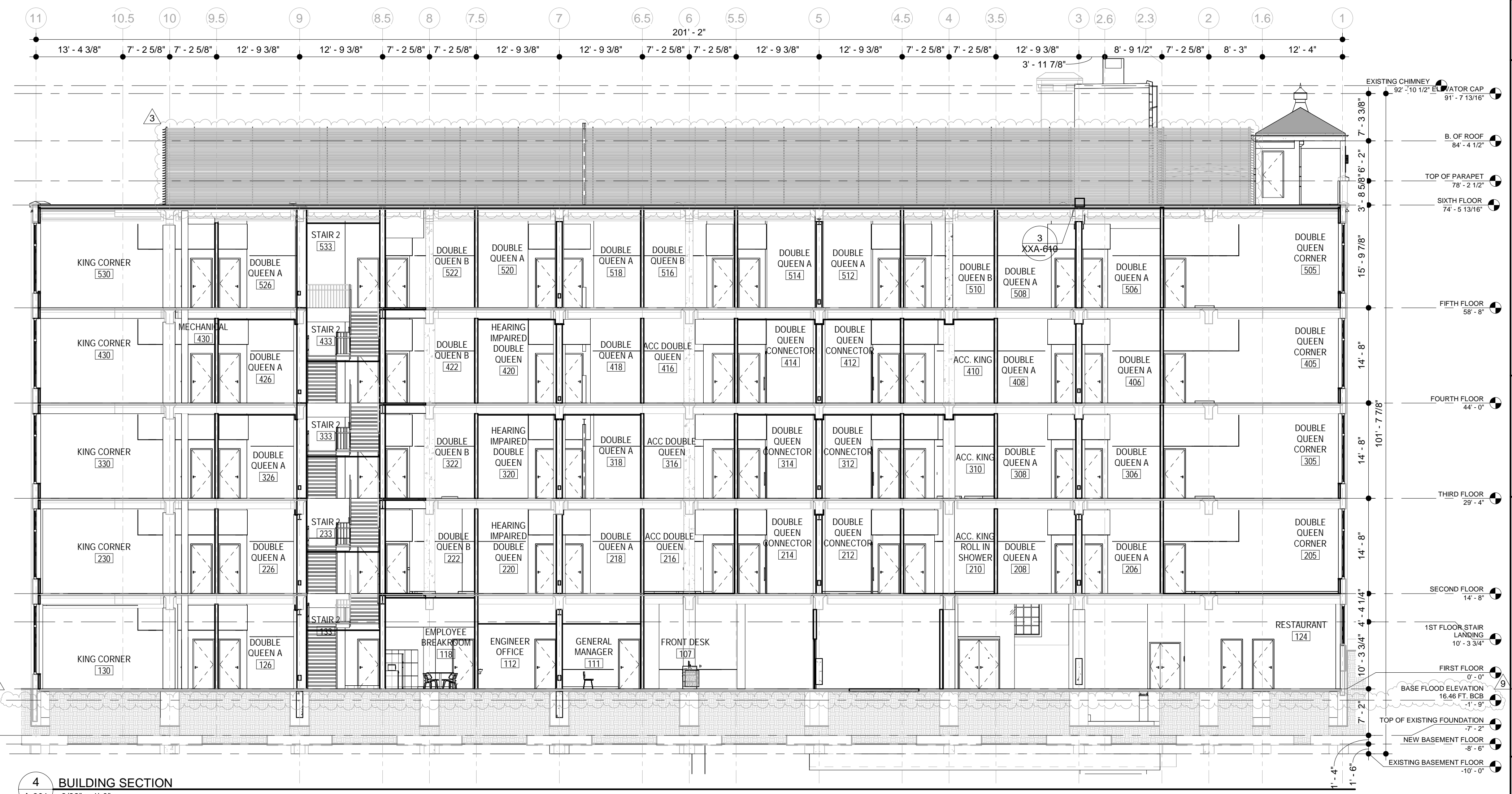

4 BUILDING SECTION
A-301 3/32" = 1'-0"

RUSSELL AND DAVISON INC.
ARCHITECTURE & ENGINEERING
1111 Main Street, East Hartford, CT 06108
TEL: (860) 282-1100 FAX: (860) 282-5272 EMAIL: russell@rda.com

REVISIONS

NO.	DESCRIPTION	DATE	BY
1	GENERAL REVISION	11/27/2019	UKP
2	GENERAL REVISION	10/12/2021	UKP

STAMP:

PROJECT: CONVERSION TO CAMBRIA SUITES
175 ORLEANS STREET, BOSTON, MA 02128

SHEET TITLE: BUILDING SECTIONS

FILE NO.: 16155.01
SCALE: 3/32" = 1'-0"
DATE: 09/29/2018
DRAWN BY: AKP
CHECKED BY: UKP

SHEET NUMBER: A-301

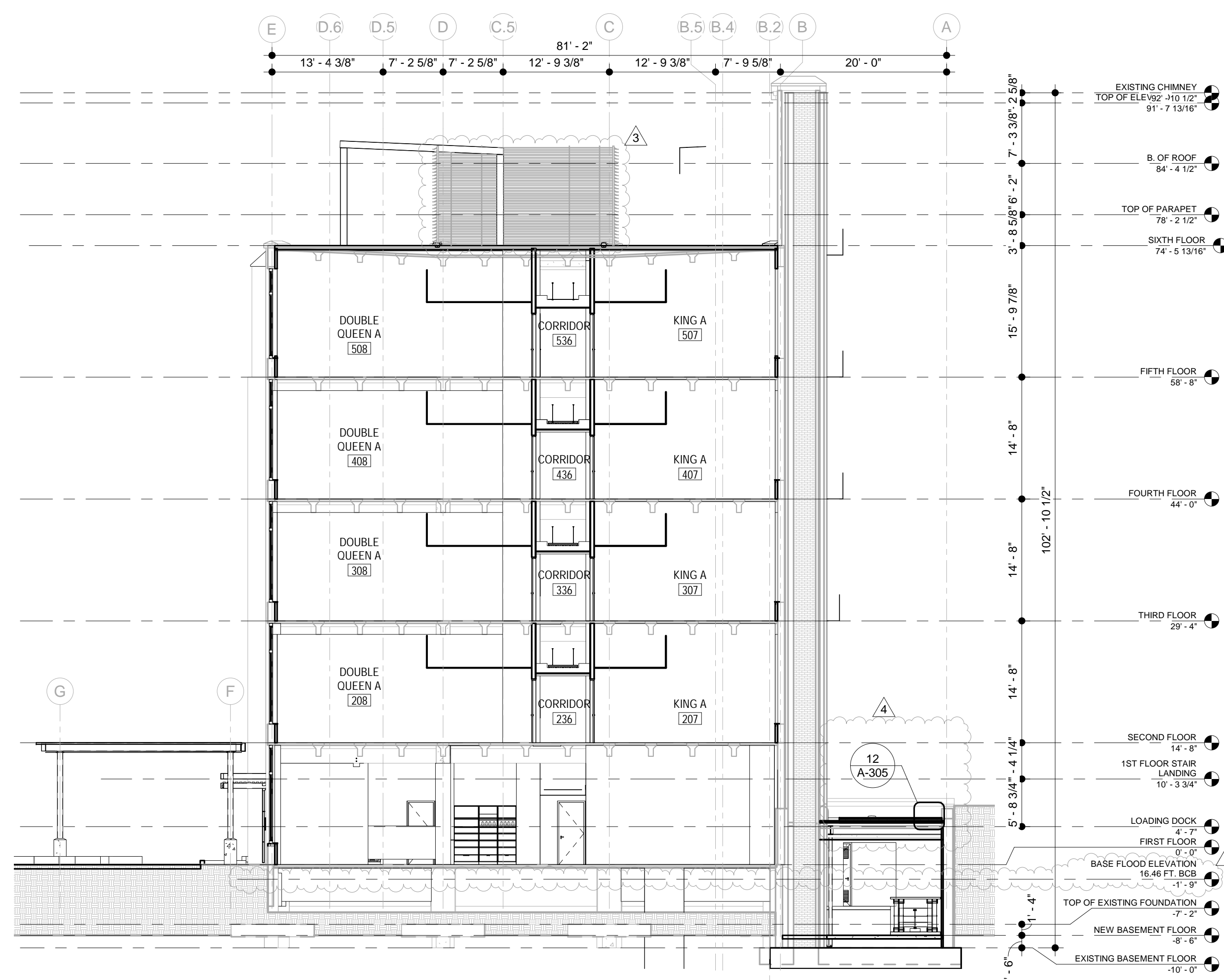

1 BUILDING SECTION
A-302 3/32" = 1'-0"

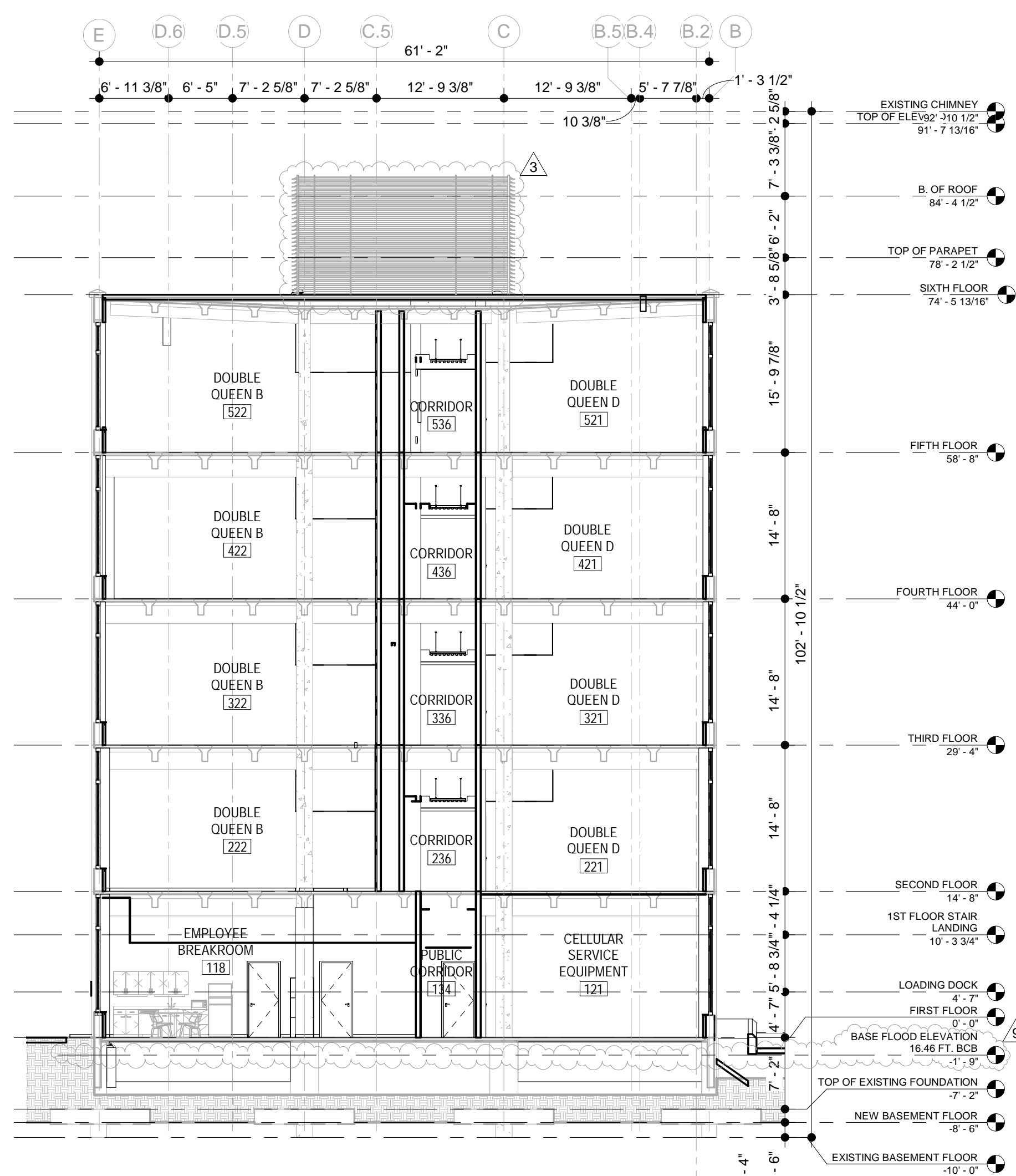

2 BUILDING SECTION
A-302 3/32" = 1'-0"

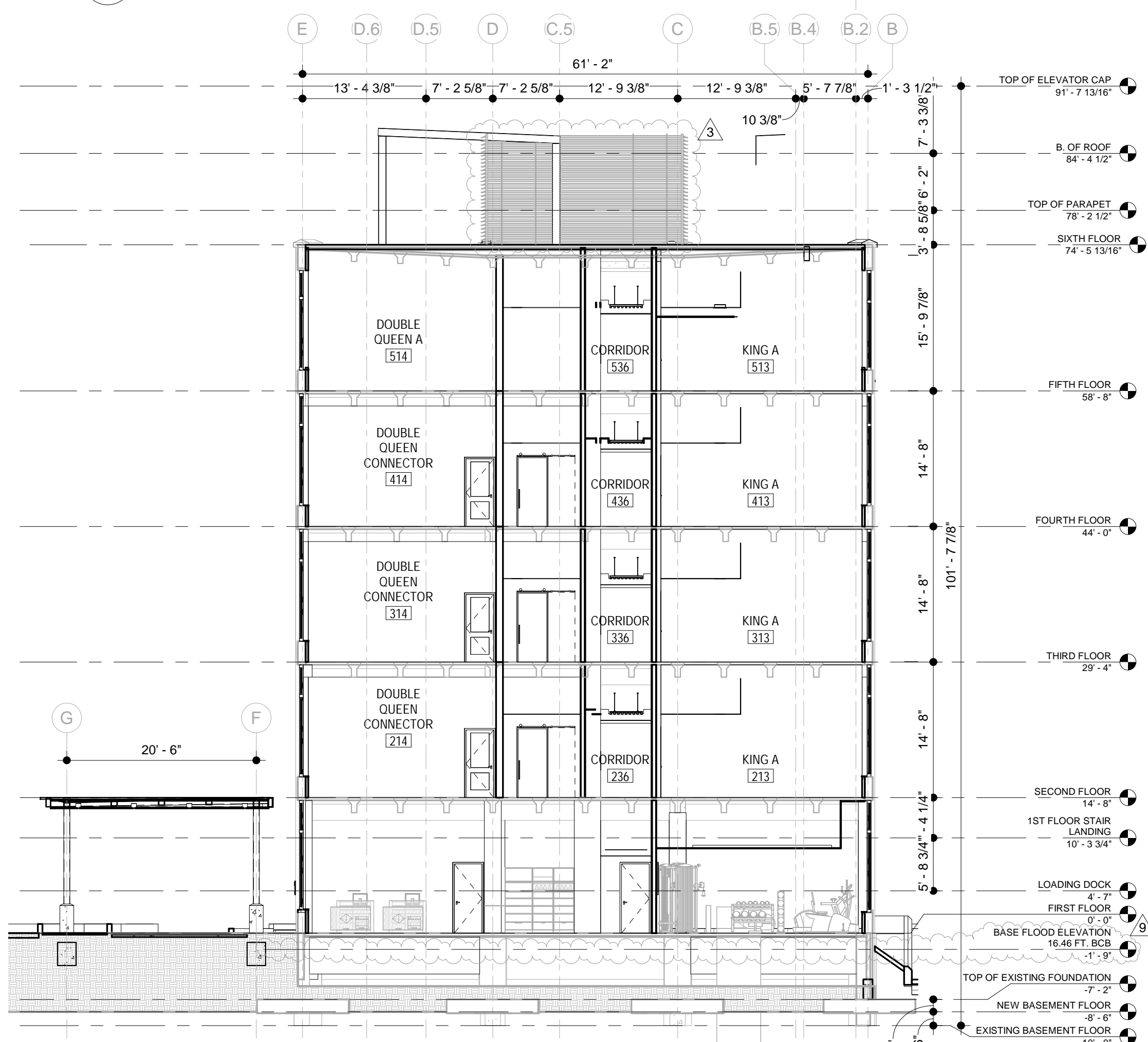

3 BUILDING SECTION
A-302 3/32" = 1'-0"

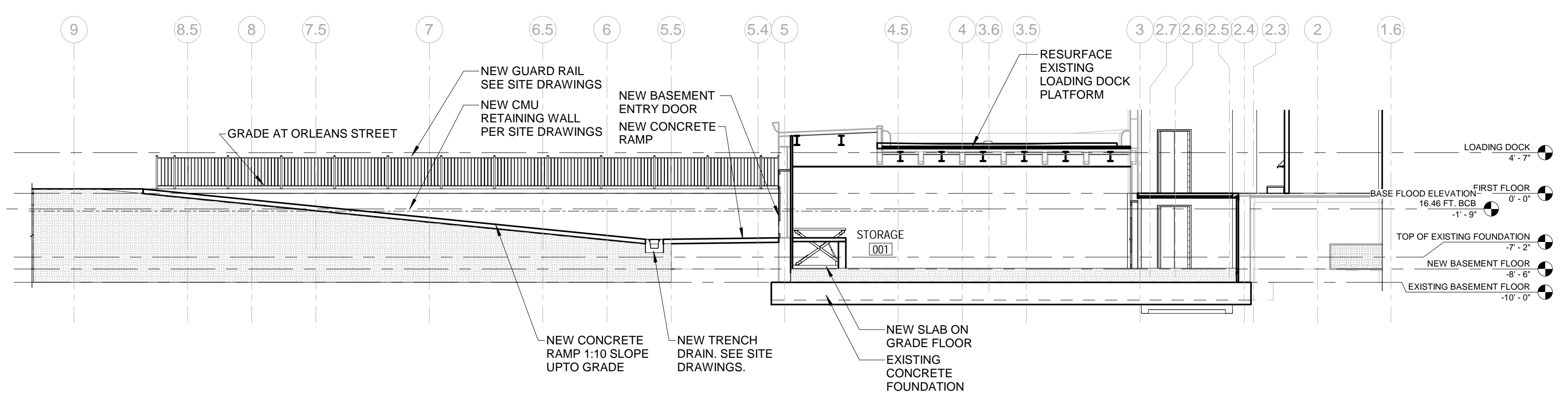

4 RAMP SECTION
A-302 1" = 10'-0"

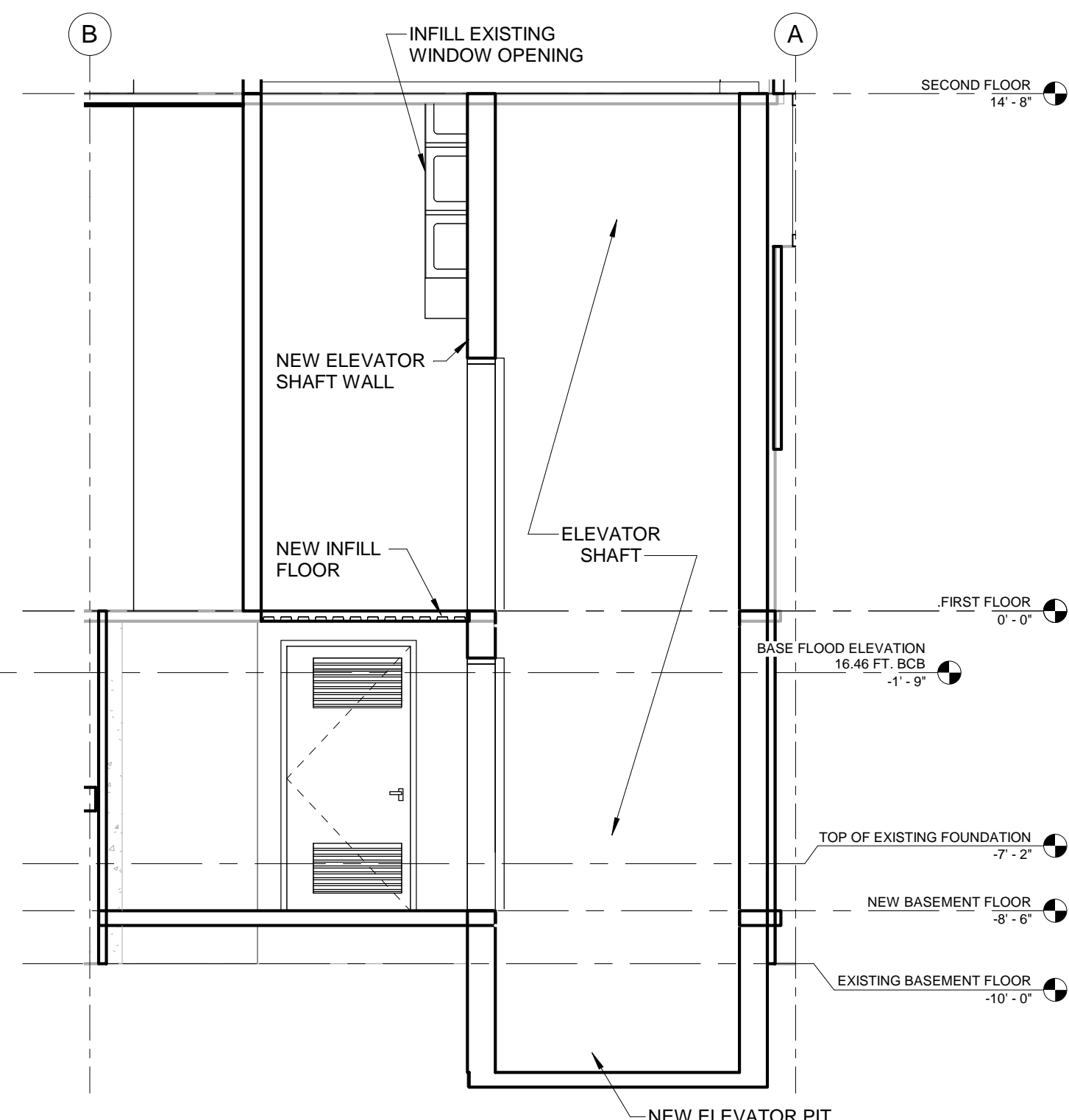

5 ELEVATOR SHAFT SECTION
A-302 1/4" = 1'-0"

<p>PROJECT: 16155.01 SCALE: As indicated DATE: 09/29/2018 DRAWN BY: AKP CHECKED BY: UKP</p>		<p>REVISIONS</p> <table border="1"> <thead> <tr> <th>NO.</th> <th>DESCRIPTION</th> <th>DATE</th> <th>BY</th> </tr> </thead> <tbody> <tr> <td>1</td> <td>GENERAL REVISION</td> <td>11/27/2019</td> <td>UKP</td> </tr> <tr> <td>3</td> <td>PER BPCA COMMENTS</td> <td>01/03/2020</td> <td>UKP</td> </tr> <tr> <td>4</td> <td>GENERAL REVISION</td> <td>10/12/2021</td> <td>UKP</td> </tr> <tr> <td>9</td> <td>GENERAL REVISION</td> <td>10/12/2021</td> <td>UKP</td> </tr> </tbody> </table>	NO.	DESCRIPTION	DATE	BY	1	GENERAL REVISION	11/27/2019	UKP	3	PER BPCA COMMENTS	01/03/2020	UKP	4	GENERAL REVISION	10/12/2021	UKP	9	GENERAL REVISION	10/12/2021	UKP
NO.	DESCRIPTION		DATE	BY																		
1	GENERAL REVISION	11/27/2019	UKP																			
3	PER BPCA COMMENTS	01/03/2020	UKP																			
4	GENERAL REVISION	10/12/2021	UKP																			
9	GENERAL REVISION	10/12/2021	UKP																			
<p>FILE NO: 16155.01 SCALE: As indicated DATE: 09/29/2018 DRAWN BY: AKP CHECKED BY: UKP</p>		<p>STAMP:</p>																				
<p>SHEET TITLE: BUILDING SECTIONS</p>		<p>PROJECT: CONVERSION TO CAMBRIA SUITES</p>																				
<p>SHEET NUMBER: A-302</p>		<p>175 ORLEANS STREET, BOSTON, MA 02128</p>																				

RUSSELL AND DAWSON INC.
ARCHITECTURE & ENGINEERING
1111 Main Street, East Hartford, CT 06108
TEL: (860) 282-1100 FAX: (860) 282-5272 EMAIL: info@rdai.com

THIS DOCUMENT, THE IDEAS, CONCEPTS, DESIGN, AND SPECIFICATIONS ARE THE PROPERTY OF RUSSELL AND DAWSON INC. AND SHALL NOT BE REPRODUCED, COPIED, OR TRANSMITTED IN ANY FORM OR BY ANY MEANS, ELECTRONIC OR MECHANICAL, INCLUDING PHOTOCOPYING, RECORDING, OR BY ANY INFORMATION STORAGE AND RETRIEVAL SYSTEM, WITHOUT THE WRITTEN PERMISSION OF RUSSELL AND DAWSON INC. © 2019 by Russell and Dawson Inc.



Climate Change Narrative and Flood Design Affidavit

June 29, 2021
August 9, 2021 (Revised)

Hotel Redevelopment
175 Orleans Street
East Boston, Massachusetts
File No. 16155.01

In construction, the best thing one can do for the environment is reuse an existing building. Russell and Dawson is proposing, on behalf of our client Hudson 62 Realty LLC, to make adaptive reuse of an existing 5-story factory building as a 123-room hotel with loft style guest suites. The original floor area and building envelope will remain with cosmetic repairs to the façade and new, more energy-efficient windows that recreate the historic appearance. In order to comply with Conservation Commission guidelines, we have proposed several measures to minimize the effect of climate change on this proposed development.

Due to the increase of greenhouse gases resulting from human activity in the atmosphere, what we expect of the northeast climate in five years or ten years is changing from what we expect next year. Climate change can be expected to have a number of effects that may impact this property, including a lack of rain or an excess of rain, a general increase or decrease in temperature, greater extremes of temperature both hot and cold, greater frequency and intensity of hurricanes and other storms, exposure to additional pandemic diseases, and sea level rise.

Climate Equity and Environmental Justice

This project will be air conditioned. In a city, anyone able to afford air conditioning dumps their excess heat on those who cannot afford it. This changes the microclimate and may result in some minor additional discomfort, but in a prolonged heat wave it might have more adverse effects. The only way we can think of to avoid this issue is to dump the heat to groundwater with a geothermal heat pump, but that does not appear to be practical on this site. Per HomeArea.com, of the 14 cities in Massachusetts Boston has the most income inequality and it is increasing. Changes to the system of income maintenance subsidies and taxation that would reduce this inequality to the point that the difference in effects of environmental degradation on the poor and the rich would be de minimis is beyond the scope of this project.

The urban heat island effect can be mitigated by selection of exterior horizontal and vertical surfaces. This building has been detailed with an EPDM roof. A white roof is preferred as sunlight is reflected rather than being turned into heat but omitting the carbon black from EPDM makes it brittle and it deteriorates more quickly. The product specified is approved for use in a High Velocity Hurricane Zone such as this one. The approval lists a bi-laminate membrane with black on the bottom and white on top. This will be selected in shop drawing approval. Trellis products appropriate for a building of this height exist that support the growth of vines. However, this is a registered historic building that would not meet the criteria of the Secretary of the Interior if such a change was made.



The large areas of glazing shown reproduce historic conditions with a more energy-efficient envelope that includes low-e glass to reduce cooling demand and heat expulsion. All of the surface area not required for parking or sidewalks has been intensively planted with groundcover, perennials, ornamental grasses, shrubs, and trees. This represents a substantial increase in pervious area compared to the existing conditions. Almost all species selected are drought tolerant per local nursery catalogs and extension services. Final selection of species will occur at purchase depending on availability. An additional criterion used in selection will be resistance to inundation by salt water. Cement concrete as used in the sidewalks is generally more reflective than bituminous concrete used in the parking areas, which receive light and radiate heat. The use of bituminous concrete has already been approved as being in conformance with Boston engineering standards. We have used concrete pavers on other projects. Coordination between public agencies in achieving climate goals, along with a review earlier in the process would be helpful. We understand that some of these issues have come to the fore during project design and approval.

Discussion of Climate Resiliency Measures

The resilience of this development and the resilience of what lies beyond it are not the same. For instance, it is possible to raise the grade of the entire site by 24" right now. That would preserve the development through the worst predictions of sea level rise. However, that would increase flooding in the areas around it that do not have the opportunity to make the same change. The best strategy for both this property and the surrounding properties is to anticipate that an increase in the floor level of the first floor may be necessary at some time in the distant future. The surface parking may flood but will not be adversely affected as the waters recede. In response to considerations of resilience we are making the following changes now that would maximize current resilience and minimize the future cost of raising the first floor: revising the section of the exit stair that discharges to the lower grade so that egress may continue to pass below the landing, raise the exterior generator and transformer platforms 24", raise the housekeeping pad of the interior electrical switchgear 24", and move the cellular equipment presently planned for the basement to a higher floor. Although there will be considerable expense in raising the first-floor level if it came to that, it is possible to just extend the sanitary connections, while electrical service cables must be continuous and would have to be replaced.

Excess stormwater is sent to the public storm sewers, but only after treatment in a new underground recharge system that can process 30,000 gallons, well in excess of that received on site in a 1" storm.

The spread of infectious disease is even more variable than the potential for flooding. Fresh air will be provided by a central system, but heating and cooling are handled room by room, so spread of disease via the HVAC system is unlikely. Interior finishes are readily cleanable. We are not proposing shields at service areas as these have proved easy to install should they be required.

The exterior envelope and HVAC system have been designed to comply with current requirements for heating and cooling. They will be able to handle occasional extremes outside the design temperatures. Should the mean temperature increase substantially, it might be necessary to introduce additional cooling capacity, but there is no reason to increase it now. The exterior envelope has been designed to comply with current requirements for insulation and for wind loading. We find no estimates of a potential for increased wind loading. Insulation performance will be augmented by changes to the HVAC system should that be needed as discussed above.



Although New England is currently in a drought, previous droughts such as that from 1962 to 1966 have been more serious and were survived without recourse to measures such as rainwater collection in a cistern. We can use a lot less water than we do, and the inhabitants of New England have demonstrated their attention to and compliance with rules such as those that might be promulgated for usage reduction should that become necessary. Also, technology that reduces water usage has become widespread since 1966 and is incorporated in this building.

We hope this information is helpful.

Very truly yours,

RUSSELL AND DAWSON INC.

Thomas A. Manning, VP - Architectural

Duly Authorized



PVI Site Design, LLC
18 Glendale Road, Norwood, MA - 339.206.1030
Master Planning - Civil Engineering - Land Entitlements

October 22, 2021

Boston Conservation Commission

Re: Hotel Redevelopment
155 Porter Street
East Boston, MA

Commission Members:

The applicant received the following comment from MA DEP:

“Applicant must demonstrate that filling of LSCSF will not cause increased flooding on adjacent properties or public ways”

The project as proposed does not create any substantial fill within the LSCSF on the property. Minor changes to grades are proposed to ensure adequate drainage across the site. These minor changes results in slightly reduced volumes on an elevation for elevation basis, however these are offset by the proposed recharge system that provides additional storage at a ratio of 3:1 for the total volume displaced.

To demonstrate this, we have performed a Compensatory Storage Analysis for the work within the LSCSF. The calculation was performed by determining the flow storage on a foot per foot basis and then comparing the results. See tables shown on the following page.

As shown in the tables, there is a cumulative reduction of 1,419 cubic feet of area within the flood zone based on contour information. The proposed recharge chamber system provides an additional 4,571 cubic feet of storage. Design calculations from the HydroCAD Model of the system are enclosed with this letter.

The final design therefore provides a net increase of 3,152 in flood storage within the LSCSF area on the property.

Sincerely,

PVI Site Design, LLC



Timothy J. Power, PE

Copy to: Bruce Toybne (Jamsan Hotel Management)
Steve Ivas (Ivas Environmental)
MA DEP

Enclosures: Compensatory Storage Calculation
Recharge System Sizing Calculation

COMPENSATORY STORAGE CALCULATION

EXISTING CONDITIONS:

Elevation	Area (SF)	Incremental Volume (CF)	Total Volume (CF)
14.8	0	0	0
15	423.4	42.34	42.34
16	9836	5129.7	5172.04
16.86	13510	10038.78	15210.82

PROPOSED CONDITIONS:

Elevation	Area (SF)	Incremental Volume (CF)	Total Volume (CF)
13	0	0	0
14	104	104	104
15	208	208	208
16	8488	4348	4556
16.86	13375	9401.09	13957

COMPARISON

Elevation	Δ by Elev.	Δ Total
14	104	104
15	166	270
16	-782	-616
16.86	-638	-1419

Additional volume from Recharge System: 4,571 CF.

Total increase in Flood Storage = 4,571 – 1,419 = 3,152 CF

1in Study - 02-07-2018

Prepared by PVI Site Design, LLC

HydroCAD® 10.00-26 s/n 09993 © 2020 HydroCAD Software Solutions LLC

Type III 24-hr 100-YR Rainfall=6.65"

Printed 10/22/2021

Summary for Pond 3P: Underground Chambers

Inflow Area = 1.155 ac, 78.94% Impervious, Inflow Depth > 5.94" for 100-YR event
 Inflow = 7.34 cfs @ 12.08 hrs, Volume= 0.572 af
 Outflow = 7.24 cfs @ 12.10 hrs, Volume= 0.479 af, Atten= 1%, Lag= 0.8 min
 Discarded = 0.00 cfs @ 2.96 hrs, Volume= 0.002 af
 Primary = 7.24 cfs @ 12.10 hrs, Volume= 0.477 af

Routing by Stor-Ind method, Time Span= 1.00-24.00 hrs, dt= 0.02 hrs
 Peak Elev= 12.93' @ 12.10 hrs Surf.Area= 2,393 sf Storage= 4,519 cf

Plug-Flow detention time= 116.9 min calculated for 0.479 af (84% of inflow)
 Center-of-Mass det. time= 50.1 min (815.4 - 765.3)

Volume	Invert	Avail.Storage	Storage Description
#1A	9.50'	1,630 cf	39.50"W x 60.58"L x 3.50"H Field A 8,375 cf Overall - 2,940 cf Embedded = 5,435 cf x 30.0% Voids
#2A	10.00'	2,940 cf	ADS_StormTech SC-740 +Cap x 64 Inside #1 Effective Size= 44.6"W x 30.0"H => 6.45 sf x 7.12'L = 45.9 cf Overall Size= 51.0"W x 30.0"H x 7.56'L with 0.44' Overlap 64 Chambers in 8 Rows
		4,571 cf	Total Available Storage

Storage Group A created with Chamber Wizard

Device	Routing	Invert	Outlet Devices
#1	Primary	10.00'	15.0" Round Culvert L= 40.0' CPP, square edge headwall, Ke= 0.500 Inlet / Outlet Invert= 10.00' / 9.50' S= 0.0125 '/' Cc= 0.900 n= 0.013 Corrugated PE, smooth interior, Flow Area= 1.23 sf
#2	Device 1	12.25'	4.0' long Sharp-Crested Rectangular Weir 2 End Contraction(s) 3.0' Crest Height
#3	Discarded	9.50'	0.020 in/hr Exfiltration over Surface area

Discarded OutFlow Max=0.00 cfs @ 2.96 hrs HW=9.54' (Free Discharge)
 ↳ **3=Exfiltration** (Exfiltration Controls 0.00 cfs)

Primary OutFlow Max=7.22 cfs @ 12.10 hrs HW=12.93' (Free Discharge)
 ↳ **1=Culvert** (Passes 7.22 cfs of 8.96 cfs potential flow)
 ↳ **2=Sharp-Crested Rectangular Weir** (Weir Controls 7.22 cfs @ 2.76 fps)



**Ivas Environmental
Environmental Sciences
Wetlands and Planning Services**

**315 Winter Street
Norwell MA 02061-1401
781.659.1690, spivas@comcast.net**

Notice of Intent

Renovation of Five-story Building into a Hotel 155 Porter St., East Boston - 15 Jul 2021



Submitted to:

**City of Boston
Conservation Commission
Boston City Hall
1 City Hall Square
Boston MA 02201**

Prepared For:

**A. Patel
Hudson 62 Realty LLC
C/O Jamsan Hotel Management
83 Hartwell Ave
Lexington MA 02421**

Notice of Intent Prepared by:

**Ivas Environmental
315 Winter Street
Norwell MA 02061**

Legal Representation:

**R. C. Lynds, Esq
245 Summer Street #110
East Boston MA 02128**

Architect:

**Russell & Dawson
1111 Main St.
East Hartford CT 06108**

Survey & Existing Conditions Plan by:

**Anderson Surveys, Inc.
800 High Street
Hanson MA 02341**

Civil Plans by:

**PVI Site Design, LLC
333 School Street
Mansfield MA 02048**

Landscape Plans by:

**RBLA Design, LLC
78 Greenlodge Street
Dedham MA 02026**



**Ivas Environmental
Environmental Sciences
Wetlands and Planning Services**

**315 Winter Street
Norwell MA 02061-1401
781.659.1690, spivas@comcast.net**

**City of Boston Conservation Commission
Boston City Hall - 1 City Hall Square
Boston MA 02201**

15 Jul 21

RE: Notice of Intent - Renovation of Existing Building into Hotel - 155 Porter St, East Boston

Dear Mr./Ms. Chairman and Members of the Commission:

Please accept the enclosed package for the renovation of a building into a hotel under the Massachusetts Wetlands and Rivers Protection Acts and implementing regulations at 310 CMR 10.00 and the City's Wetlands Protection Ordinance, Chapter VII of the City's Code, dated 11 Dec 19, on behalf of A. Patel and Hudson 62 Realty LLC.

The building at 155 Porter Street (also known as 175 Orleans Street) was the Shearlingwear Factory. Renovation into a 123-room hotel with loft-style guest suites is the proposed project, that includes two at-grade parking lots adjacent to the structure. This reuse project will use the existing floor area and building envelope, Cosmetic repairs will occur to the facade, and energy-efficient windows that recreate the historic appearance will be installed.

The wetland resource is Land Subject to Coastal Storm Flowage (LSCSF). There are no other sensitive wetland resources within about 1,000 feet of the subject site. The closest is a NHESP Estimated Habitat of Rare Wildlife and Priority Habitat of Rare Species that overlie one another about 2,000 feet northwest of the site, in coastal waters. The Habitats are numbered EH 999 and PH 1364. Therefore, NHESP review is not involved.

Typical environmental preventive construction methods (See Exhibit B, Performance Standard Discussion) shall be utilized to ensure protection of the interests under the Wetlands and Rivers Protection Acts and the City's Ordinance. Mulch socks shall be used at the property limits to prevent erosion or sedimentation products from leaving the site. No direct or indirect impacts on any wetland resource is anticipated from the construction and operation of the existing five-story hotel building.

If you have any questions, please contact me or Bruce Tobyne, Construction Manager at 781.413.4327.

Sincerely,



Steve Ivas, MS, PWS, Principal

XC: MA DEP DWWR, MassDEP Northeast Regional Office, 205B Lowell St., Wilmington MA 01887
A. Patel, Hudson 62 Realty LL, c/o Jamsan Hotel Management, 83 Hartwell Ave, Lexington MA 02421

Boston Conservation Commission - NOI - 155 Porter St., East Boston - Renovation to Hotel - 15 Jul 21 - Page 2/2

Encl: WPA - Form 3 - Notice of Intent - 155 Porter St., East Boston
Wetland Fee Transmittal Form
MA DEP Transmittal Form for Permit Application and Payment
City of Boston Notice of Intent Form - 155 Porter St., East Boston

Ex. A - Project Description - 155 Porter St., East Boston - 06 Jun 21
Ex. B - Performance Standard Discussion - 155 Porter St., East Boston - 06 Jun 21
Fig. 1 - USGS Locus Map - 155 Porter St., 155 Porter St., East Boston - 16 May 21
Fig. 2 - Orthophoto - 155 Porter St., 155 Porter St., East Boston - 16 May 21
Fig. 3 - Natural Heritage Map - 155 Porter St., 155 Porter St., East Boston - 16 May 21
Fig. 4 - FEMA Flood Map - 155 Porter St., 155 Porter St., East Boston - 16 May 21
NRCS Web Soil Survey Report - 155 Porter St., East Boston - 16 May 21
Ex. C - Plan List - 155 Porter St., East Boston - 15 Jul 21

Abutters Mailing List Method - 06 Jun 21
Abutters Map - Generated by City of Boston Assessors on 06 Jun 21
Abutters List from City of Boston Mailing List Generator, 06 Jun 21
Abutters Notification Form - English
Abutters Notification Form - Spanish
Babel Notice for Abutters Notification - 27 Jun 21
Affidavit of Service for Abutters' Notification Form (Provided to Boston Conservation Commission digitally after mailing of abutters' notification, along with copies of USPS Form 3877)

Stormwater Management Standards Narrative - signed and stamped by T. Power, P.E. - 15 Jun 21
Stormwater Management Checklist
Stormwater Management Standards Narrative
Stormwater Operations and Maintenance Plan
Supporting Calculations

- Stage Storage Table
- TSS Removal Calculations

NRCS Soils Maps

Elevation Certificate - Anderson Survey - 06 Jun 2021
Illicit Discharge Statement - 13 Jul 2021

Climate Resiliency Checklist - Russell and Dawson
Climate Change Narrative & Flood Design Narrative - Russell & Dawson - 29 Jun 21

ZBA Decision - Case No. BOA889510 -Permit #ALT878760 - 15 Mar 2019
Request for Extension of Granted Variances and Vote of Board of Appeal Members of 12 Jan 2021
BPDA Contract Document Approval - 25 Nov 2020

Boston Conservation Commission Notice of Intent Checklist
Copies of Checks

- 7715 - City of Boston - \$1,500.00 (over \$100,000 project cost),
- 7716 - City of Boston - \$550.00 (Category 3 - Building); and
- 7713 - Commonwealth of Massachusetts - \$737.50 (½ Category 3)

Plans: See Exhibit C, above for a list of Plans

File: C:\2021\Wetlands\Boston\155 Porter St\NOI Cov Let - 15Jul21.wpd



Massachusetts Department of Environmental Protection
Bureau of Resource Protection - Wetlands

WPA Form 3 – Notice of Intent

Massachusetts Wetlands Protection Act M.G.L. c. 131, §40

Provided by MassDEP:

MassDEP File Number

Document Transaction Number

EAST BOSTON

City/Town

Important:

When filling out forms on the computer, use only the tab key to move your cursor - do not use the return key.



Note:
Before completing this form consult your local Conservation Commission regarding any municipal bylaw or ordinance.

A. General Information

1. Project Location (**Note:** electronic filers will click on button to locate project site):

155 Porter Street
a. Street Address

East Boston
b. City/Town

02128
c. Zip Code

Latitude and Longitude:
42.371620 N
d. Latitude

-71.033860 W
e. Longitude

Three Parcels:
f. Assessors Map/Plat Number

103926000, 103927000, and 103928000
g. Parcel /Lot Number

2. Applicant:

Ashok
a. First Name

Patel
b. Last Name

Hudson 62 Realty LLC
c. Organization

C/O Jamsan Hotel Management, 83 Hartwell Avenue
d. Street Address

Lexington
e. City/Town

MA
f. State

02421
g. Zip Code

781.856.8206
h. Phone Number

i. Fax Number

apatel@jamsan.us
j. Email Address

3. Property owner (required if different from applicant): Check if more than one owner

a. First Name

b. Last Name

c. Organization

d. Street Address

e. City/Town

f. State

g. Zip Code

h. Phone Number

i. Fax Number

j. Email address

4. Representative (if any):

Steve
a. First Name

Ivas
b. Last Name

Ivas Environmental
c. Company

315 Winter Street
d. Street Address

Norwell
e. City/Town

MA
f. State

02061-1401
g. Zip Code

781.659.1690
h. Phone Number

i. Fax Number

spivas@comcast.net
j. Email address

5. Total WPA Fee Paid (from NOI Wetland Fee Transmittal Form):

\$737.50
a. Total Fee Paid

\$737.50
b. State Fee Paid

None - City has own Fee Schedule



Massachusetts Department of Environmental Protection
Bureau of Resource Protection - Wetlands

WPA Form 3 – Notice of Intent

Massachusetts Wetlands Protection Act M.G.L. c. 131, §40

Provided by MassDEP:
MassDEP File Number
Document Transaction Number
EAST BOSTON
City/Town

A. General Information (continued)

6. General Project Description:

Revelopment of existing building and two parking lots to a hotel with two parking lots.

7a. Project Type Checklist: (Limited Project Types see Section A. 7b.)

- 1. Single Family Home
- 2. Residential Subdivision
- 3. Commercial/Industrial
- 4. Dock/Pier
- 5. Utilities
- 6. Coastal engineering Structure
- 7. Agriculture (e.g., cranberries, forestry)
- 8. Transportation
- 9. Other

7b. Is any portion of the proposed activity eligible to be treated as a limited project (including Ecological Restoration Limited Project) subject to 310 CMR 10.24 (coastal) or 310 CMR 10.53 (inland)?

- 1. Yes No If yes, describe which limited project applies to this project. (See 310 CMR 10.24 and 10.53 for a complete list and description of limited project types)

2. Limited Project Type

If the proposed activity is eligible to be treated as an Ecological Restoration Limited Project (310 CMR10.24(8), 310 CMR 10.53(4)), complete and attach Appendix A: Ecological Restoration Limited Project Checklist and Signed Certification.

8. Property recorded at the Registry of Deeds for:

Suffolk	
a. County	b. Certificate # (if registered land)
57405	192, 197, & 224 (3 Parcels)
c. Book	d. Page Number

B. Buffer Zone & Resource Area Impacts (temporary & permanent)

- 1. Buffer Zone Only – Check if the project is located only in the Buffer Zone of a Bordering Vegetated Wetland, Inland Bank, or Coastal Resource Area.
- 2. Inland Resource Areas (see 310 CMR 10.54-10.58; if not applicable, go to Section B.3, Coastal Resource Areas).

Check all that apply below. Attach narrative and any supporting documentation describing how the project will meet all performance standards for each of the resource areas altered, including standards requiring consideration of alternative project design or location.



Massachusetts Department of Environmental Protection
Bureau of Resource Protection - Wetlands

WPA Form 3 – Notice of Intent

Massachusetts Wetlands Protection Act M.G.L. c. 131, §40

Provided by MassDEP:

MassDEP File Number

Document Transaction Number

EAST BOSTON

City/Town

B. Buffer Zone & Resource Area Impacts (temporary & permanent) (cont'd)

For all projects affecting other Resource Areas, please attach a narrative explaining how the resource area was delineated.

Resource Area	Size of Proposed Alteration	Proposed Replacement (if any)
a. <input type="checkbox"/> Bank	1. linear feet	2. linear feet
b. <input type="checkbox"/> Bordering Vegetated Wetland	1. square feet	2. square feet
c. <input type="checkbox"/> Land Under Waterbodies and Waterways	1. square feet	2. square feet
	3. cubic yards dredged	

Resource Area	Size of Proposed Alteration	Proposed Replacement (if any)
d. <input type="checkbox"/> Bordering Land Subject to Flooding	1. square feet	2. square feet
	3. cubic feet of flood storage lost	4. cubic feet replaced
e. <input type="checkbox"/> Isolated Land Subject to Flooding	1. square feet	
	2. cubic feet of flood storage lost	3. cubic feet replaced
f. <input type="checkbox"/> Riverfront Area	1. Name of Waterway (if available) - specify coastal or inland	

2. Width of Riverfront Area (check one):

- 25 ft. - Designated Densely Developed Areas only
- 100 ft. - New agricultural projects only
- 200 ft. - All other projects

3. Total area of Riverfront Area on the site of the proposed project: _____ square feet

4. Proposed alteration of the Riverfront Area:

a. total square feet _____ b. square feet within 100 ft. _____ c. square feet between 100 ft. and 200 ft. _____

5. Has an alternatives analysis been done and is it attached to this NOI? Yes No

6. Was the lot where the activity is proposed created prior to August 1, 1996? Yes No

3. Coastal Resource Areas: (See 310 CMR 10.25-10.35)

Note: for coastal riverfront areas, please complete **Section B.2.f.** above.



Massachusetts Department of Environmental Protection
 Bureau of Resource Protection - Wetlands

WPA Form 3 – Notice of Intent

Massachusetts Wetlands Protection Act M.G.L. c. 131, §40

Provided by MassDEP:

MassDEP File Number

Document Transaction Number

EAST BOSTON

City/Town

B. Buffer Zone & Resource Area Impacts (temporary & permanent) (cont'd)

Check all that apply below. Attach narrative and supporting documentation describing how the project will meet all performance standards for each of the resource areas altered, including standards requiring consideration of alternative project design or location.

Online Users:
 Include your document transaction number (provided on your receipt page) with all supplementary information you submit to the Department.

<u>Resource Area</u>	<u>Size of Proposed Alteration</u>	<u>Proposed Replacement (if any)</u>
a. <input type="checkbox"/> Designated Port Areas	Indicate size under Land Under the Ocean, below	
b. <input type="checkbox"/> Land Under the Ocean	_____	
	1. square feet	

	2. cubic yards dredged	
c. <input type="checkbox"/> Barrier Beach	Indicate size under Coastal Beaches and/or Coastal Dunes below	
d. <input type="checkbox"/> Coastal Beaches	_____	
	1. square feet	2. cubic yards beach nourishment
e. <input type="checkbox"/> Coastal Dunes	_____	
	1. square feet	2. cubic yards dune nourishment
	<u>Size of Proposed Alteration</u>	<u>Proposed Replacement (if any)</u>
f. <input type="checkbox"/> Coastal Banks	_____	
	1. linear feet	
g. <input type="checkbox"/> Rocky Intertidal Shores	_____	
	1. square feet	
h. <input type="checkbox"/> Salt Marshes	_____	
	1. square feet	2. sq ft restoration, rehab., creation
i. <input type="checkbox"/> Land Under Salt Ponds	_____	
	1. square feet	

	2. cubic yards dredged	
j. <input type="checkbox"/> Land Containing Shellfish	_____	
	1. square feet	
k. <input type="checkbox"/> Fish Runs	Indicate size under Coastal Banks, inland Bank, Land Under the Ocean, and/or inland Land Under Waterbodies and Waterways, above	

	1. cubic yards dredged	
l. <input checked="" type="checkbox"/> Land Subject to Coastal Storm Flowage	12,116 sf	
	1. square feet	

4. Restoration/Enhancement
 If the project is for the purpose of restoring or enhancing a wetland resource area in addition to the square footage that has been entered in Section B.2.b or B.3.h above, please enter the additional amount here.

_____	_____
a. square feet of BVW	b. square feet of Salt Marsh

5. Project Involves Stream Crossings

_____	_____
a. number of new stream crossings	b. number of replacement stream crossings



Massachusetts Department of Environmental Protection
Bureau of Resource Protection - Wetlands

WPA Form 3 – Notice of Intent

Massachusetts Wetlands Protection Act M.G.L. c. 131, §40

Provided by MassDEP:

MassDEP File Number

Document Transaction Number

EAST BOSTON

City/Town

C. Other Applicable Standards and Requirements

- This is a proposal for an Ecological Restoration Limited Project. Skip Section C and complete Appendix A: Ecological Restoration Limited Project Checklists – Required Actions (310 CMR 10.11).

Streamlined Massachusetts Endangered Species Act/Wetlands Protection Act Review

1. Is any portion of the proposed project located in **Estimated Habitat of Rare Wildlife** as indicated on the most recent Estimated Habitat Map of State-Listed Rare Wetland Wildlife published by the Natural Heritage and Endangered Species Program (NHESP)? To view habitat maps, see the *Massachusetts Natural Heritage Atlas* or go to http://maps.massgis.state.ma.us/PRI_EST_HAB/viewer.htm.

- a. Yes No **If yes, include proof of mailing or hand delivery of NOI to:**

**Natural Heritage and Endangered Species Program
Division of Fisheries and Wildlife
1 Rabbit Hill Road
Westborough, MA 01581**

- 01 Aug 2017
b. Date of map

If yes, the project is also subject to Massachusetts Endangered Species Act (MESA) review (321 CMR 10.18). To qualify for a streamlined, 30-day, MESA/Wetlands Protection Act review, please complete Section C.1.c, and include requested materials with this Notice of Intent (NOI); *OR* complete Section C.2.f, if applicable. *If MESA supplemental information is not included with the NOI, by completing Section 1 of this form, the NHESP will require a separate MESA filing which may take up to 90 days to review (unless noted exceptions in Section 2 apply, see below).*

- c. Submit Supplemental Information for Endangered Species Review*

1. Percentage/acreage of property to be altered:
- (a) within wetland Resource Area _____ percentage/acreage
- (b) outside Resource Area _____ percentage/acreage
2. Assessor's Map or right-of-way plan of site
2. Project plans for entire project site, including wetland resource areas and areas outside of wetlands jurisdiction, showing existing and proposed conditions, existing and proposed tree/vegetation clearing line, and clearly demarcated limits of work **
- (a) Project description (including description of impacts outside of wetland resource area & buffer zone)
- (b) Photographs representative of the site

* Some projects **not** in Estimated Habitat may be located in Priority Habitat, and require NHESP review (see <https://www.mass.gov/endangered-species-act-mesa-regulatory-review>).

Priority Habitat includes habitat for state-listed plants and strictly upland species not protected by the Wetlands Protection Act.

** MESA projects may not be segmented (321 CMR 10.16). The applicant must disclose full development plans even if such plans are not required as part of the Notice of Intent process.



Massachusetts Department of Environmental Protection
Bureau of Resource Protection - Wetlands

WPA Form 3 – Notice of Intent

Massachusetts Wetlands Protection Act M.G.L. c. 131, §40

Provided by MassDEP:

MassDEP File Number

Document Transaction Number

EAST BOSTON

City/Town

C. Other Applicable Standards and Requirements (cont'd)

- (c) MESA filing fee (fee information available at <https://www.mass.gov/how-to/how-to-file-for-a-mesa-project-review>).

Make check payable to "Commonwealth of Massachusetts - NHESP" and **mail to NHESP** at above address

Projects altering 10 or more acres of land, also submit:

- (d) Vegetation cover type map of site

- (e) Project plans showing Priority & Estimated Habitat boundaries

- (f) OR Check One of the Following

1. Project is exempt from MESA review.
Attach applicant letter indicating which MESA exemption applies. (See 321 CMR 10.14, <https://www.mass.gov/service-details/exemptions-from-review-for-projectsactivities-in-priority-habitat>; the NOI must still be sent to NHESP if the project is within estimated habitat pursuant to 310 CMR 10.37 and 10.59.)

2. Separate MESA review ongoing. _____ a. NHESP Tracking # _____ b. Date submitted to NHESP

3. Separate MESA review completed.
Include copy of NHESP "no Take" determination or valid Conservation & Management Permit with approved plan.

3. For coastal projects only, is any portion of the proposed project located below the mean high water line or in a fish run?

- a. Not applicable – project is in inland resource area only b. Yes No

If yes, include proof of mailing, hand delivery, or electronic delivery of NOI to either:

South Shore - Cohasset to Rhode Island border, and
the Cape & Islands:

North Shore - Hull to New Hampshire border:

Division of Marine Fisheries -
Southeast Marine Fisheries Station
Attn: Environmental Reviewer
836 South Rodney French Blvd.
New Bedford, MA 02744
Email: dmf.envreview-south@mass.gov

Division of Marine Fisheries -
North Shore Office
Attn: Environmental Reviewer
30 Emerson Avenue
Gloucester, MA 01930
Email: dmf.envreview-north@mass.gov

Also if yes, the project may require a Chapter 91 license. For coastal towns in the Northeast Region, please contact MassDEP's Boston Office. For coastal towns in the Southeast Region, please contact MassDEP's Southeast Regional Office.

- c. Is this an aquaculture project? d. Yes No

If yes, include a copy of the Division of Marine Fisheries Certification Letter (M.G.L. c. 130, § 57).



Massachusetts Department of Environmental Protection
Bureau of Resource Protection - Wetlands

WPA Form 3 – Notice of Intent

Massachusetts Wetlands Protection Act M.G.L. c. 131, §40

Provided by MassDEP:

MassDEP File Number

Document Transaction Number

EAST BOSTON

City/Town

C. Other Applicable Standards and Requirements (cont'd)

4. Is any portion of the proposed project within an Area of Critical Environmental Concern (ACEC)?
- a. Yes No If yes, provide name of ACEC (see instructions to WPA Form 3 or MassDEP Website for ACEC locations). **Note:** electronic filers click on Website.
- b. ACEC
5. Is any portion of the proposed project within an area designated as an Outstanding Resource Water (ORW) as designated in the Massachusetts Surface Water Quality Standards, 314 CMR 4.00?
- a. Yes No
6. Is any portion of the site subject to a Wetlands Restriction Order under the Inland Wetlands Restriction Act (M.G.L. c. 131, § 40A) or the Coastal Wetlands Restriction Act (M.G.L. c. 130, § 105)?
- a. Yes No
7. Is this project subject to provisions of the MassDEP Stormwater Management Standards?
- a. Yes. Attach a copy of the Stormwater Report as required by the Stormwater Management Standards per 310 CMR 10.05(6)(k)-(q) and check if:
1. Applying for Low Impact Development (LID) site design credits (as described in Stormwater Management Handbook Vol. 2, Chapter 3)
 2. A portion of the site constitutes redevelopment
 3. Proprietary BMPs are included in the Stormwater Management System.
- b. No. Check why the project is exempt:
1. Single-family house
 2. Emergency road repair
 3. Small Residential Subdivision (less than or equal to 4 single-family houses or less than or equal to 4 units in multi-family housing project) with no discharge to Critical Areas.

D. Additional Information

- This is a proposal for an Ecological Restoration Limited Project. Skip Section D and complete Appendix A: Ecological Restoration Notice of Intent – Minimum Required Documents (310 CMR 10.12).

Applicants must include the following with this Notice of Intent (NOI). See instructions for details.

Online Users: Attach the document transaction number (provided on your receipt page) for any of the following information you submit to the Department.

1. USGS or other map of the area (along with a narrative description, if necessary) containing sufficient information for the Conservation Commission and the Department to locate the site. (Electronic filers may omit this item.)
2. Plans identifying the location of proposed activities (including activities proposed to serve as a Bordering Vegetated Wetland [BVW] replication area or other mitigating measure) relative to the boundaries of each affected resource area.

Online Users:
Include your document transaction number (provided on your receipt page) with all supplementary information you submit to the Department.



Massachusetts Department of Environmental Protection
Bureau of Resource Protection - Wetlands

WPA Form 3 – Notice of Intent

Massachusetts Wetlands Protection Act M.G.L. c. 131, §40

Provided by MassDEP:
MassDEP File Number
Document Transaction Number
EAST BOSTON
City/Town

D. Additional Information (cont'd)

3. Identify the method for BVW and other resource area boundary delineations (MassDEP BVW Field Data Form(s), Determination of Applicability, Order of Resource Area Delineation, etc.), and attach documentation of the methodology.

4. List the titles and dates for all plans and other materials submitted with this NOI.

Please see the cover letter for a list of the plans and documents attached to this NOI.

a. Plan Title

b. Prepared By

c. Signed and Stamped by

d. Final Revision Date

e. Scale

f. Additional Plan or Document Title

g. Date

5. If there is more than one property owner, please attach a list of these property owners not listed on this form.

6. Attach proof of mailing for Natural Heritage and Endangered Species Program, if needed.

7. Attach proof of mailing for Massachusetts Division of Marine Fisheries, if needed.

8. Attach NOI Wetland Fee Transmittal Form

9. Attach Stormwater Report, if needed.

E. Fees

1. Fee Exempt: No filing fee shall be assessed for projects of any city, town, county, or district of the Commonwealth, federally recognized Indian tribe housing authority, municipal housing authority, or the Massachusetts Bay Transportation Authority.

Applicants must submit the following information (in addition to pages 1 and 2 of the NOI Wetland Fee Transmittal Form) to confirm fee payment:

None - Boston has its own fee schedule

None - Boston has its own fee schedule

2. Municipal Check Number

3. Check date

7713

10 Jul 21

4. State Check Number

5. Check date

Ivas

Environmental

6. Payor name on check: First Name

7. Payor name on check: Last Name

4. State Check Number
Ivas

5. Check date
Environmental





6. Payor name on check: First Name

7. Payor name on check: Last Name

F. Signatures and Submittal Requirements

I hereby certify under the penalties of perjury that the foregoing Notice of Intent and accompanying plans, documents, and supporting data are true and complete to the best of my knowledge. I understand that the Conservation Commission will place notification of this Notice in a local newspaper at the expense of the applicant in accordance with the wetlands regulations, 310 CMR 10.05(5)(a).

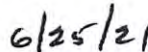
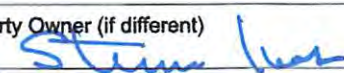
I further certify under penalties of perjury that all abutters were notified of this application, pursuant to the requirements of M.G.L. c. 131, § 40. Notice must be made by Certificate of Mailing or in writing by hand delivery or certified mail (return receipt requested) to all abutters within 100 feet of the property line of the project location.

		
1. Signature of Applicant		2. Date
3. Signature of Property Owner (if different)		4. Date
5. Signature of Representative (if any)		 6. Date

For Conservation Commission:

Two copies of the completed Notice of Intent (Form 3), including supporting plans and documents, two copies of the NOI Wetland Fee Transmittal Form, and the city/town fee payment, to the Conservation Commission by certified mail or hand delivery.

For MassDEP:

One copy of the completed Notice of Intent (Form 3), including supporting plans and documents, one copy of the NOI Wetland Fee Transmittal Form, and a **copy** of the state fee payment to the MassDEP Regional Office (see Instructions) by certified mail or hand delivery.

Other:

If the applicant has checked the "yes" box in any part of Section C, Item 3, above, refer to that section and the Instructions for additional submittal requirements.

The original and copies must be sent simultaneously. Failure by the applicant to send copies in a timely manner may result in dismissal of the Notice of Intent.



Massachusetts Department of Environmental Protection
 Bureau of Resource Protection - Wetlands
NOI Wetland Fee Transmittal Form
 Massachusetts Wetlands Protection Act M.G.L. c. 131, §40

Important: When filling out forms on the computer, use only the tab key to move your cursor - do not use the return key.

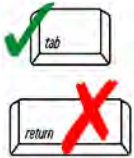

A. Applicant Information

1. Location of Project:

<u>155 Porter Street</u>	<u>East Boston</u>
a. Street Address	b. City/Town
<u>7713</u>	<u>\$737.50</u>
c. Check number	d. Fee amount

2. Applicant Mailing Address:

<u>Ashok</u>	<u>Patel</u>	
a. First Name	b. Last Name	
<u>Hudson 62 Realty LLC</u>		
c. Organization		
<u>C/O Jamsan Hotel Management, 83 Hartwell Avenue</u>		
d. Mailing Address		
<u>Lexington</u>	<u>MA</u>	<u>02421</u>
e. City/Town	f. State	g. Zip Code
<u>781.856.8206</u>	<u>apatel@jamsan.us</u>	
h. Phone Number	i. Fax Number	j. Email Address

3. Property Owner (if different):

<u></u>	<u></u>	
a. First Name	b. Last Name	
<u></u>		
c. Organization		
<u></u>		
d. Mailing Address		
<u></u>	<u></u>	<u></u>
e. City/Town	f. State	g. Zip Code
<u></u>	<u></u>	
h. Phone Number	i. Fax Number	j. Email Address

B. Fees

Fee should be calculated using the following process & worksheet. **Please see Instructions before filling out worksheet.**

Step 1/Type of Activity: Describe each type of activity that will occur in wetland resource area and buffer zone.

Step 2/Number of Activities: Identify the number of each type of activity.

Step 3/Individual Activity Fee: Identify each activity fee from the six project categories listed in the instructions.

Step 4/Subtotal Activity Fee: Multiply the number of activities (identified in Step 2) times the fee per category (identified in Step 3) to reach a subtotal fee amount. Note: If any of these activities are in a Riverfront Area in addition to another Resource Area or the Buffer Zone, the fee per activity should be multiplied by 1.5 and then added to the subtotal amount.

Step 5/Total Project Fee: Determine the total project fee by adding the subtotal amounts from Step 4.

Step 6/Fee Payments: To calculate the state share of the fee, divide the total fee in half and subtract \$12.50. To calculate the city/town share of the fee, divide the total fee in half and add \$12.50.

To calculate filing fees, refer to the category fee list and examples in the instructions for filling out WPA Form 3 (Notice of Intent).



Massachusetts Department of Environmental Protection
 Bureau of Resource Protection - Wetlands
NOI Wetland Fee Transmittal Form
 Massachusetts Wetlands Protection Act M.G.L. c. 131, §40

B. Fees (continued)

Step 1/Type of Activity	Step 2/Number of Activities	Step 3/Individual Activity Fee	Step 4/Subtotal Activity Fee
Cat 3(b) Building	One	\$1500	\$1500
_____	_____	_____	_____
_____	_____	_____	_____
_____	_____	_____	_____
_____	_____	_____	_____
_____	_____	_____	_____
_____	_____	_____	_____
_____	_____	_____	_____

Step 5/Total Project Fee: _____

Step 6/Fee Payments:

Total Project Fee:	<u>\$1,500.00</u>
	a. Total Fee from Step 5
State share of filing Fee:	<u>\$737.50</u>
	b. 1/2 Total Fee less \$12.50
City/Town share of filing Fee:	None-Boston has its own fee schedule

C. Submittal Requirements

- a.) Complete pages 1 and 2 and send with a check or money order for the state share of the fee, payable to the Commonwealth of Massachusetts.

Department of Environmental Protection
 Box 4062
 Boston, MA 02211

- b.) **To the Conservation Commission:** Send the Notice of Intent or Abbreviated Notice of Intent; a **copy** of this form; and the city/town fee payment.

To MassDEP Regional Office (see Instructions): Send a copy of the Notice of Intent or Abbreviated Notice of Intent; a **copy** of this form; and a **copy** of the state fee payment. (E-filers of Notices of Intent may submit these electronically.)



INSTRUCTIONS FOR COMPLETING APPLICATION NOTICE OF INTENT – BOSTON NOI FORM

The Boston Notice of Intent Form is intended to be a supplement to the WPA Form 3 detailing impacts to locally designated wetland resource areas and buffer zones. Please read these instructions for assistance in completing the Notice of Intent application form. These instructions cover certain items on the Notice of Intent form that are not self-explanatory.

INSTRUCTIONS TO SECTION B: BUFFER ZONE AND RESOURCE AREA IMPACTS

Item 1. Buffer Zone Only. If you check the Buffer Zone Only box in this section you are indicating that the project is entirely in the Buffer Zone to a resource area **under both** the Wetlands Protection Act and Boston Wetlands Ordinance. If so, skip the remainder of Section B and go directly to Section C. Do not check this box if the project is within the Waterfront Area.

Item 2. The **boundaries of coastal resource areas** specific to the Ordinance can be found in Section II of the Boston Wetlands Regulations. You must also include the size of the proposed alterations (and proposed replacement areas) in each resource area.

Item 3. The **boundaries of inland resource areas** specific to the Ordinance can be found in Section II of the Boston Wetlands Regulations. You must also include the size of the proposed alterations (and proposed replacement areas) in each resource area.

INSTRUCTIONS TO SECTION C: OTHER APPLICABLE STANDARDS AND REQUIREMENTS

Item 1. Rare Wetland Wildlife Habitat. Except for Designated Port Areas, no work (including work in the Buffer Zone) may be permitted in any resource area that would have adverse effects on the habitat of rare, “state-listed” vertebrate or invertebrate animal species.

The most recent Estimated Habitat Map of State-Listed Rare Wetland Wildlife is published by the Natural Heritage and Endangered Species Program (NHESP). See: http://maps.massgis.state.ma.us/PRI_EST_HAB/viewer.htm or the *Massachusetts Natural Heritage Atlas*.

If any portion of the proposed project is located within Estimated Habitat, the applicant must send the Natural Heritage Program, at the following address, a copy of the Notice of Intent by certified mail or priority mail (or otherwise sent in a manner that guarantees delivery within two days), no later than the date of the filing of the Notice of Intent with the Conservation Commission.

Evidence of mailing to the Natural Heritage Program (such as Certified Mail Receipt or Certificate of Mailing for Priority Mail) must be submitted to the Conservation Commission along with the Notice of Intent.

Natural Heritage and Endangered Species Program
Division of Fisheries and Wildlife
1 Rabbit Hill Road
Westborough, MA 01581-3336
508.792.7270



A. GENERAL INFORMATION

1. Project Location

<u>155 Porter Street</u>	<u>East Boston</u>	<u>02128</u>
a. Street Address	b. City/Town	c. Zip Code
<u>103926000, 103927000, & 103928000</u>	<u>103926000, 103927000, & 103928000</u>	
f. Assessors Map/Plat Number	g. Parcel /Lot Number	

2. Applicant

<u>Ashok</u>	<u>Patel</u>	<u>Hudson 62 Realty LLC</u>
a. First Name	b. Last Name	c. Company
<u>C/O Jamsan Hotel Management, 83 Hartwell Ave</u>		
d. Mailing Address		
<u>Lexington</u>	<u>MA</u>	<u>02421</u>
e. City/Town	f. State	g. Zip Code
<u>781.856.8206</u>	<u>apatel@jamsan.us</u>	
h. Phone Number	i. Fax Number	j. Email address

3. Property Owner

<u>Hudson 62 Realty LLC</u>		
a. First Name	b. Last Name	c. Company
<u>C/O Jamsan Hotel Management, 83 Hartwell Ave</u>		
d. Mailing Address		
<u>Lexington</u>	<u>MA</u>	<u>02421</u>
e. City/Town	f. State	g. Zip Code
<u>781.856.8206</u>	<u>apatel@jamsan.us</u>	
h. Phone Number	i. Fax Number	j. Email address

Check if more than one owner

(If there is more than one property owner, please attach a list of these property owners to this form.)

4. Representative (if any)

<u>Steve</u>	<u>Ivas</u>	<u>Ivas Environmental</u>
a. First Name	b. Last Name	c. Company
<u>315 Winter Street</u>		
d. Mailing Address		
<u>Norwell</u>	<u>MA</u>	<u>02061-1401</u>
e. City/Town	f. State	g. Zip Code
<u>781.659.1690</u>	<u>spivas@comcast.net</u>	
h. Phone Number	i. Fax Number	j. Email address



5. Is any portion of the proposed project jurisdictional under the Massachusetts Wetlands Protection Act M.G.L. c. 131 §40?

- Yes No

If yes, please file the WPA Form 3 - Notice of Intent with this form

6. General Information

Project is hotel redevelopment of existing five-story building, including two parking lots - one along Orleans St., and one along Frankfort St., S and E of the building at the corner of Porter & Orleans Sts. Please refer to attached plans.

7. Project Type Checklist

- a. Single Family Home
- b. Residential Subdivision
- c. Limited Project Driveway Crossing
- d. Commercial/Industrial
- e. Dock/Pier
- f. Utilities
- g. Coastal Engineering Structure
- h. Agriculture – cranberries, forestry
- i. Transportation
- j. Other

8. Property recorded at the Registry of Deeds

<u>Suffolk</u>	<u>192, 197, & 224 (3 Parcels)</u>
a. County	b. Page Number
<u>57405</u>	_____
c. Book	d. Certificate # (if registered land)

9. Total Fee Paid

<u>\$2,787.50.00</u>	<u>\$737.50</u>	<u>\$550.00 + \$1,500.00 = \$2050.00</u>
a. Total Fee Paid	b. State Fee Paid	c. City Fee Paid

B. BUFFER ZONE & RESOURCE AREA IMPACTS

Buffer Zone Only - Is the project located only in the Buffer Zone of a resource area protected by the Boston Wetlands Ordinance?

- Yes No

1. Coastal Resource Areas



<u>Resource Area</u>	<u>Resource Area Size</u>	<u>Proposed Alteration*</u>	<u>Proposed Mitigation</u>
<input checked="" type="checkbox"/> Coastal Flood Resilience Zone	50,329sf Square feet	36,770 Square feet	_____ Square feet
<input type="checkbox"/> 25-foot Waterfront Area	_____ Square feet	_____ Square feet	_____ Square feet
<input type="checkbox"/> 100-foot Salt Marsh Area	_____ Square feet	_____ Square feet	_____ Square feet
<input type="checkbox"/> Riverfront Area	_____ Square feet	_____ Square feet	_____ Square feet

2. Inland Resource Areas

<u>Resource Area</u>	<u>Resource Area Size</u>	<u>Proposed Alteration*</u>	<u>Proposed Mitigation</u>
<input type="checkbox"/> Inland Flood Resilience Zone	_____ Square feet	_____ Square feet	_____ Square feet
<input type="checkbox"/> Isolated Wetlands	_____ Square feet	_____ Square feet	_____ Square feet
<input type="checkbox"/> Vernal Pool	_____ Square feet	_____ Square feet	_____ Square feet
<input type="checkbox"/> Vernal Pool Habitat (vernal pool + 100 ft. upland area)	_____ Square feet	_____ Square feet	_____ Square feet
<input type="checkbox"/> 25-foot Waterfront Area	_____ Square feet	_____ Square feet	_____ Square feet
<input type="checkbox"/> Riverfront Area	_____ Square feet	_____ Square feet	_____ Square feet

C. OTHER APPLICABLE STANDARDS & REQUIREMENTS

1. What other permits, variances, or approvals are required for the proposed activity described herein and what is the status of such permits, variances, or approvals?

- _____
BRA / BPDA Approval - 10 Dec 2015
- _____
ZBA Variances Granted - 11 Dec 2018
- _____
Board of Appeal - Decision Extended Until 15 Mar 2022
- _____
ISD - Final Building Permit - Expected after OOC from Conservation Commission
- _____



2. Is any portion of the proposed project located in Estimated Habitat of Rare Wildlife as indicated on the most recent Estimated Habitat Map of State-Listed Rare Wetland Wildlife published by the Natural Heritage and Endangered Species Program (NHESP)? To view habitat maps, see the Massachusetts Natural Heritage Atlas or go to <http://www.mass.gov/dfwele/dfw/nhosp/nhregmap.htm>.
- Yes No

If yes, the project is subject to Massachusetts Endangered Species Act (MESA) review (321 CMR 10.18).

A. Submit Supplemental Information for Endangered Species Review

- Percentage/acreage of property to be altered:
- (1) within wetland Resource Area _____ percentage/acreage
- (2) outside Resource Area _____ percentage/acreage
- Assessor's Map or right-of-way plan of site

3. Is any portion of the proposed project within an Area of Critical Environmental Concern?
- Yes No

If yes, provide the name of the ACEC: _____

4. Is the proposed project subject to provisions of the Massachusetts Stormwater Management Standards?

- Yes. Attach a copy of the Stormwater Checklist & Stormwater Report as required.
- Applying for a Low Impact Development (LID) site design credits
 - A portion of the site constitutes redevelopment
 - Proprietary BMPs are included in the Stormwater Management System
- No. Check below & include a narrative as to why the project is exempt
- Single-family house
 - Emergency road repair
 - Small Residential Subdivision (less than or equal to 4 single family houses or less than or equal to 4 units in a multifamily housing projects) with no discharge to Critical Areas

5. Is the proposed project subject to Boston Water and Sewer Commission Review?
- Yes No



D. SIGNATURES AND SUBMITTAL REQUIREMENTS

I hereby certify under the penalties of perjury that the foregoing Notice of Intent and accompanying plans, documents, and supporting data are true and complete to the best of my knowledge. I understand that the Conservation Commission will place notification of this Notice in a local newspaper at the expense of the applicant in accordance with the Wetlands Protection Ordinance.

Apater Apater
Signature of Applicant

6/25/21
Date

Signature of Property Owner (if different)

Date

Stimber
Signature of Representative (if any)

28 JUN 21
Date

Hotel Redevelopment - 155 Porter Street, East Boston
Exhibit A - Project Description - 06 Jun 21

The hotel redevelopment project at 155 Porter Street transforms the former Sterlingwear Peacoat Factory into a hotel with two surface parking lots. The project uses three parcels of land, specifically, Assessors parcels 013926000 (14,000 sf) and 0103927000 (22,000 sf) along Orleans Street and parcel 0103928000 (14,404 sf) at the corner of Frankfort and Porter Streets. The total area of the three lots is about 50,404 sf. The existing structure, which is presently gutted, will be renovated into a five-story hotel. Please see the attached Parcel Plan (PL100, 26 Nov 2019) by PVI Site Design for the relationships among the three parcels, the attached Figure 1 for the general location of the site, and Figure 2 for a detailed aerial photo of the site in 2019. This latter 1:1,000 scale-figure shows the three parcels outlined in various shade of red.

The Site Plan by Anderson Surveys, Inc. dated 06 Apr 2017 shows the detailed location of the AE Flood Zone that is extant on the southern-most Orleans Street Property. This Flood Zone (Boston City Base, or BCB) of 16.46 feet (NAV88 of 10.0 ft) provides the basis for the City's Conservation Commission jurisdiction of the project. About three-quarters of the southern-most parcel along Orleans Street is within the AE Flood Zone. The remainder of the site is outside any flood zone.

Figure 3 shows the Natural Heritage and Endangered Species Program (NHESP) data layers in the surrounding area: There are no Areas of Critical Environmental Concern (ACECs), Estimated Habitats of Rare Wildlife or Priority Habitats of Rare Species or Certified Vernal Pools (CVPs) that can be affected by the proposed redevelopment project.

Construction Staging, Access and Egress: Construction access and egress will be from Orleans Street into the southern-most parcel. Access to the entire construction site will be controlled with a fence system with a gate wide enough for heavy equipment off Orleans Street. Right hand turns into and out from the site to Orleans Street will be the access and egress modes. Staging will take place on the southern-most parcel as well.

Site Preparation: Please review the Site Preparation Plan (C100) dated 26 Nov 2019 by PVI Site Design LLC for the details of the site preparation activities. The existing fence around the site is to be removed, and a construction fence is to be installed. The existing pavement in the two parking lots is to be pulverized and used as fill material as needed. A concrete pad on the southern-most parcel along Orleans Street is to be removed. A curb on this parcel is to be removed. Crushed stone on the west side of the building is to be removed.

The bulkhead on the west side of the building is to be retained, and the generators on the east side of the building are to be decommissioned and removed, and the concrete pads on which they are placed are to be demolished. The majority of the existing sidewalks and curbs along Orleans, Porter, and Frankfort Streets are to be protected, as are the utility elements and fixtures within the public right of way.

The Layout and Materials Plan, (C101, dated 20 Nov 2020 by PVI Site Design, LLC) provides additional details of the proposed parking lots and building exterior. Main hotel access will be on the east side of the building facing the Frankfort Street parking area. Concrete stairs will be installed down from Porter Street along the easterly side of the building. The existing curb cut from Porter Street will be closed and a new curb cut from Porter Street installed.

The Frankfort Street parking lot will feature electric vehicle charging stations, reserved parking for car pool / van pool, and inverted “U” bike racks set close to the building, as well as handicapped parking. The Orleans Street parking lot will contain additional parking spaces a pad and enclosure for two 8-yard dumpsters and two curb cuts from Orleans Street - one for visitor parking, and one for access to the at-grade loading access to the building’s basement. It will also include an area for a ride-sharing program

Stormwater Management: Plan sheet C102 (by PVI Site Design, LLC dated 02 Jan 2020) provides a Grading and Utility Plan from which stormwater management measures can be reviewed. The roof drains to the easterly side of the building, into a system that picks up sheet flows into two catch basins in the Frankfort Street Parking Lot, along with a catch basin at the southeast corner of the building, and at the northwest corner of the Orleans Street parking lot, routing stormwater to the center of the Orleans Street Lot where there are a series of 64 underground recharge chambers. The system retains one inch of rainfall for the entire site. The recharge chambers overflow to a 48 x 51 inch City Combined Sewer. The Basement access roadway contains a separate stormwater system: it is composed of a trench drain and catch basin with a four-foot deep sump and hood that overflows into the City’s Combined Sewer.

Landscaping. The Landscape Plan, Notes, Details, and Schedule are found on Plan Sheet L101, dated 26 Nov 2019, by RBLA DESIGN, LLC. Trees and shrubs are proposed for the site along Orleans Street, Frankfort Street, and Porter Street east of the Hotel Building. The southerly side of the Frankfort Street Parking Lot and the east and south sides of the Orleans Parking Lot are also proposed for trees and shrubs, as is the center of the Frankfort Parking Lot perpendicular to the Hotel’s front entry. A planting island is also proposed for the northeast portion of the Orleans Street Parking Lot, southeast of the generator installation, and another island is at the westerly end of the parking aisle, opposite the Orleans Street entry.

Hotel Redevelopment - 155 Porter Street, East Boston
Exhibit B - Performance Standards Discussion - 06 Jun 21

While there are no performance standards associated with Land Subject to Coastal Storm Flowage (LSCSF), there are methods and techniques that address some of the protected interests of the Wetlands Protection Act while a project is undergoing construction. These include the following interests and responses.

1. **Protection of public and private water supply.** There are no known public or water supply wells that could be affected by work on the site.

2. **Protection of ground water supply.** There will be subsurface excavation for the replacement of utility lines to the building presently on the site. Other sub-surface excavation is for 64 Infiltration Chambers for subsurface infiltration facility. Please see the Proposed Grading and Utility Plan (Sheet C102) 02 Jan 2020 by PVI Site Design, LLC for the location of the existing and proposed subsurface facilities.

Rain leaders from the roof of the building direct storm water into the sub-surface Stormtech Chamber SC-740 or equivalent Infiltration Galleries. Each of these chambers contains 6.48 cubic ft per linear Foot volume. These facilities are not anticipated to intercept local groundwater. The StormTech sub-surface drainage facilities shall act as a first defense site for any contaminants to the groundwater supply, although it is also unlikely that contaminants shall flow from the building's roof. The overflow from the Stormtech chambers overflows a weir set at 12.25 ft, and enters the City's existing drainage system.

3. **Flood control.** A portion of the site is within the one percent (1 %) return frequency for storm events, in the FEMA FIRM AE (elevation 10.0 ft, NAVD 88, elevation 16.46 ft BCB) Flood Zone that emanates from Land Subject to Coastal Storm Flowage (LSCSF). During construction, this interest shall be protected by ensuring all project-related materials are secured before any storm events to prevent damage from material moving off-site. Additionally, materials shall be staged for minimum time periods to ensure there is no volumetric impact on flooding in the surrounding area. When possible, project materials shall be staged above elevation 10.0 feet NAVD 88, 16.46 ft BCB.





4. **Prevention of pollution.** Disposal of all demolition debris and construction materials shall be completed in accordance with all federal, state, and local laws and regulations. Bills of lading and manifests shall be available in the project office. Drip pans shall be utilized for all vehicles and equipment requiring fueling when on site overnight. Drip pans shall also be used under all fuel containers if they are to be staged on site. Any dumpsters brought to the site shall not have voids which can leak liquids. Containment (e.g., tarps and underlayment methods) shall be used on staged materials that could cause pollution of the site. Street catch basins shall be protected from any impacts from the construction project, including adding protection within the catch basin, as appropriate. No petroleum products or hydraulic fluids shall be stored overnight within the AE Flood Zone on the site.

5. **Protection of fisheries and land containing shellfish.** Please see No. 4, above.

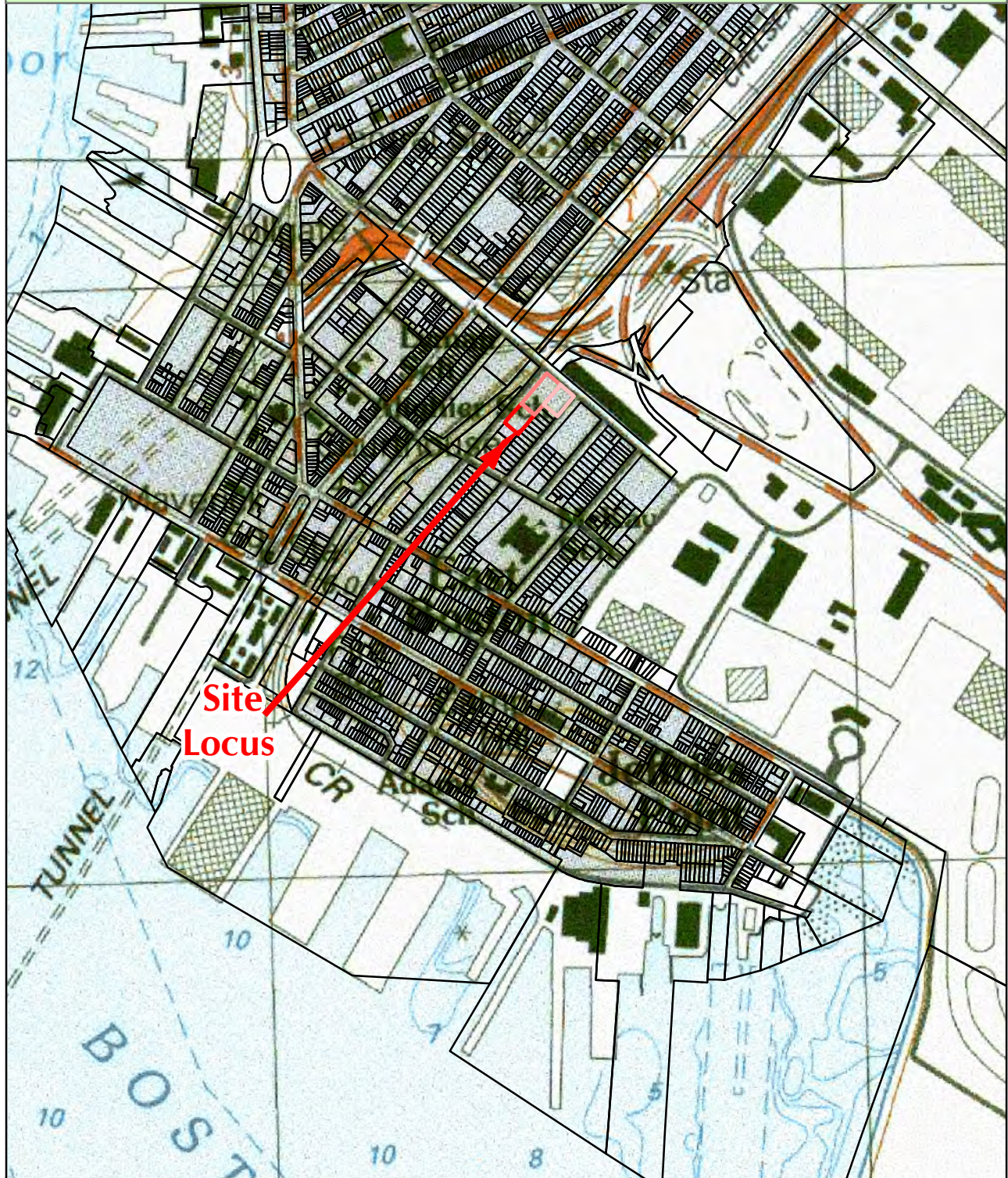
- 6. Protection of wildlife habitat.** The methods cited in the sections above shall appropriately protect any wildlife habitat that is extant within the site: While the Custom Soil Resource Report (Page 9) dated 16 May 21 shows trees extant on the Frankfort Street Parking Lot area, and adjacent to the Orleans Street parking area, these trees nor are their branches visible on the 2019 1:1000 Orthophoto of the area. There appears to be a few trees directly adjacent to the easterly boundary of the Orleans Street Parking Lot, offsite.

Fig. 1 - Site Locus 155 Porter Street, East Boston



-  155_Porter_St. - Parcel_1
-  155_Porter_St. - Parcel_2
-  155_Porter_St. - Parcel_3
-  MassGIS / Boston Assessors' Parcels

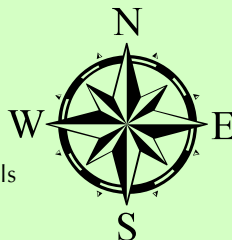

Scale: 1:10,000



Ivas Environmental
315 Winter St., Norwell MA 02061-1401
781.659.1690, spivas@comcast.net

E:\2020\Wetlands\Boston\155 Paris St.\Fig 1 - 16 May 21.mxd

Sources:
USGS Seamless Topographic Quadrangles (usgs.sid)
MassGIS/ Boston Tax Parcels (Par35.shp)

Projection: Massachusetts State Plane NAD 83 M

Fig. 2 - 2019 Orthophoto & Data Layers Around 155 Porter Street, East Boston

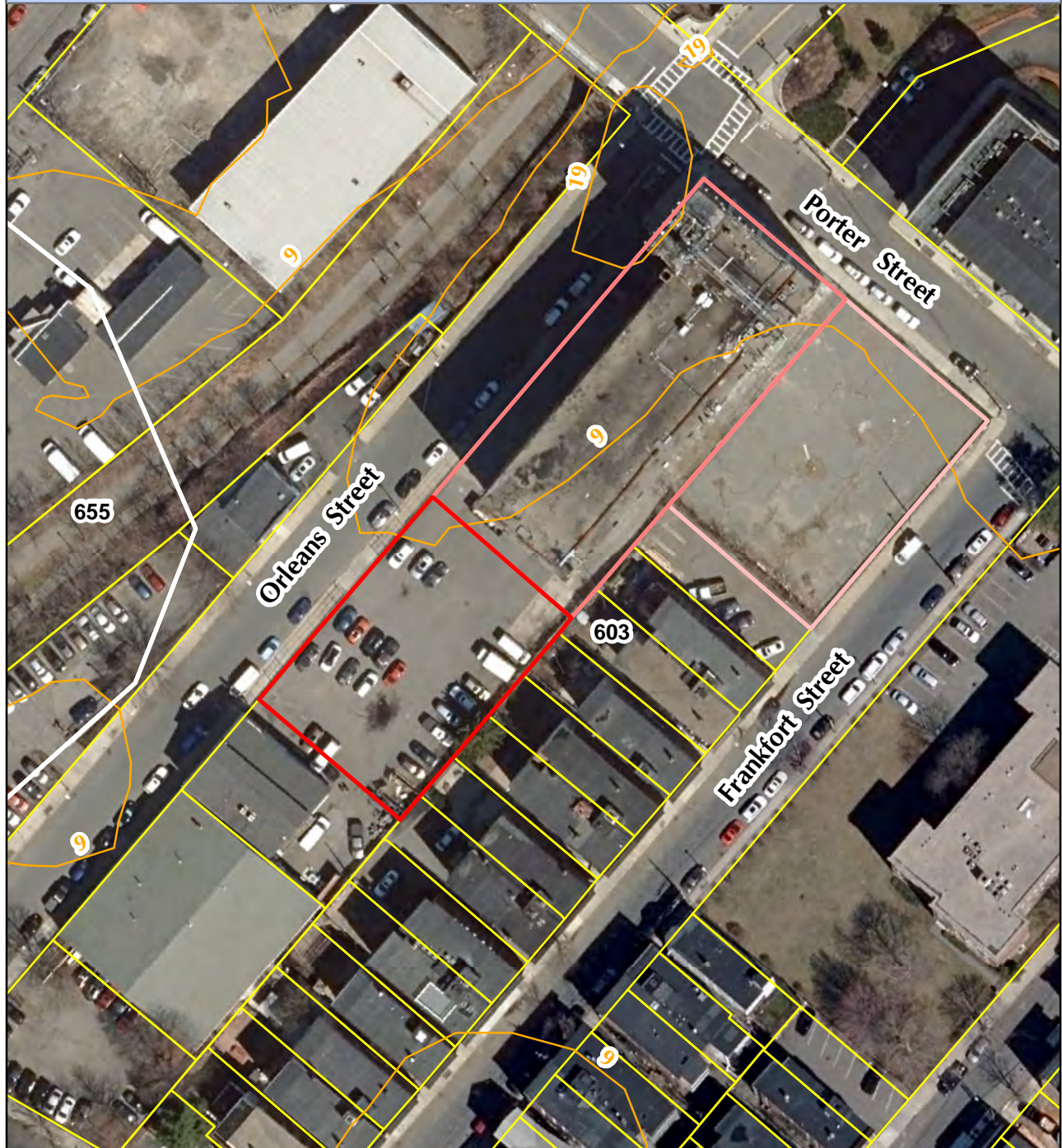

-  NRCS Soils - Norfolk & Suffolk Cos.
-  155_Porter_St._ - Parcel_1
-  155_Porter_St._ - Parcel_2
-  155_Porter_St._ - Parcel_3
-  2009 MA DEP Wetlands - Polygons
-  2009 MA DEP Wetlands - Boundaries
-  MassGIS Elevation Contours (ft) - Boston
-  MassGIS / Boston Assessors' Parcels

603 Urban land, wet substratum, undulating
 655 Udorthents, wet substratum, undulating



Ivas Environmental
 315 Winter St., Norwell MA 02061-1401
 781.659.1690, spivas@comcast.net

E:\2021\Wetlands\Boston\155 Porter St.\Fig 2 - 16 May 21.mxd

Sources:
 MasGIS 2019 Orthophoto (19TCG315290.jp2)
 MassGIS/ Boston Tax Parcels (Par35.shp)
 MA DEP 2009 Wetlands Polygons (madep_wet_poly.shp)
 MA DEP 2009 Wetlands Boundaries (madepwet_arc.shp)
 MassGIS Elevation Contours (hp35.shp)

Projection: Massachusetts State Plane NAD 83 M

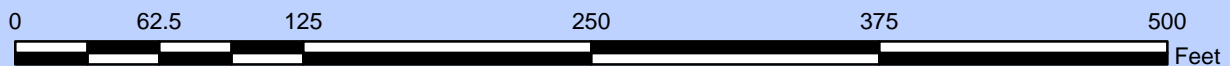
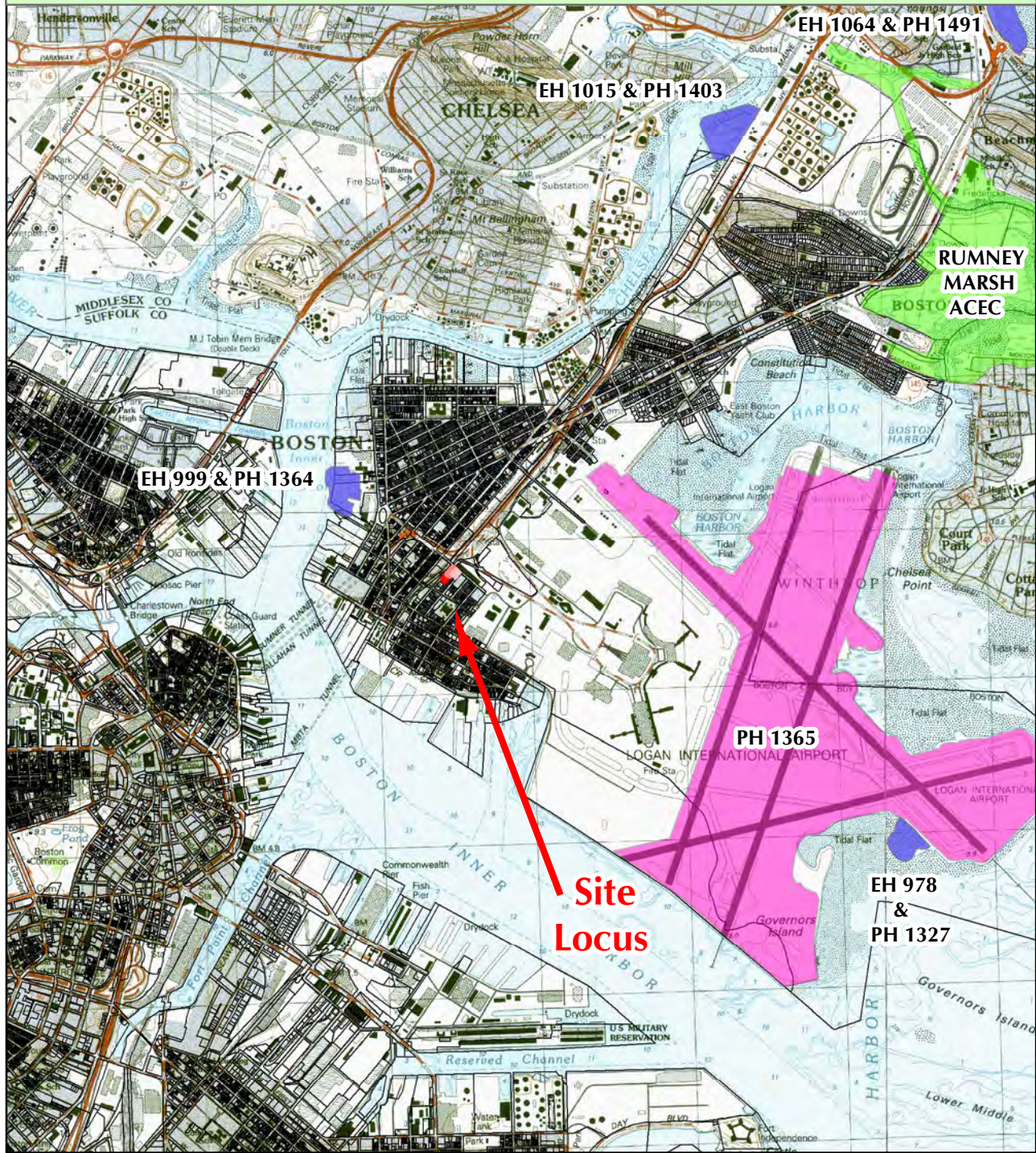
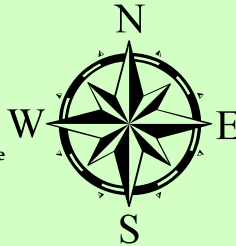

Fig. 3 - NHESP Data Layers Around 155 Porter Street, East Boston



- 155 Porter St. - Parcel 1
- 155 Porter St. - Parcel 2
- 155 Porter St. - Parcel 3
- NHESP 2020 Certified Vernal Pools
- NHESP 2017 Estimated Habitats of Rare Wildlife
- NHESP 2017 Priority Habitats of Rare Species
- Areas of Critical Environmental Concern
- MassGIS / Boston Assessors' Parcels



Ivas Environmental
315 Winter St., Norwell MA 02061-1401
781.659.1690, spivas@comcast.net

E:\2020\Wetlands\Boston\155 Porter St.\Fig. 3 - 16 May 21.mxd

Sources:

- USGS Seamless Topographic Quadrangles (usgs.sid)
- MassGIS/ Boston Tax Parcels (Par35.shp)
- NHESP 2020 Certified Vernal Pools (cvp_pt.shp)
- NHESP 2017 Estimated Habitats of Rare Wildlife (esthab_poly.shp)
- NHESP 2017 Priority Habitats of Rare Species (prihab_poly.shp)
- EOEEA Areas of Critical Environmental Concern (acecs_poly.shp)

Scale: 1:40,000

Projection: Massachusetts State Plane NAD 83 M



National Flood Hazard Layer FIRMette



71°22'1"W 42°22'31"N

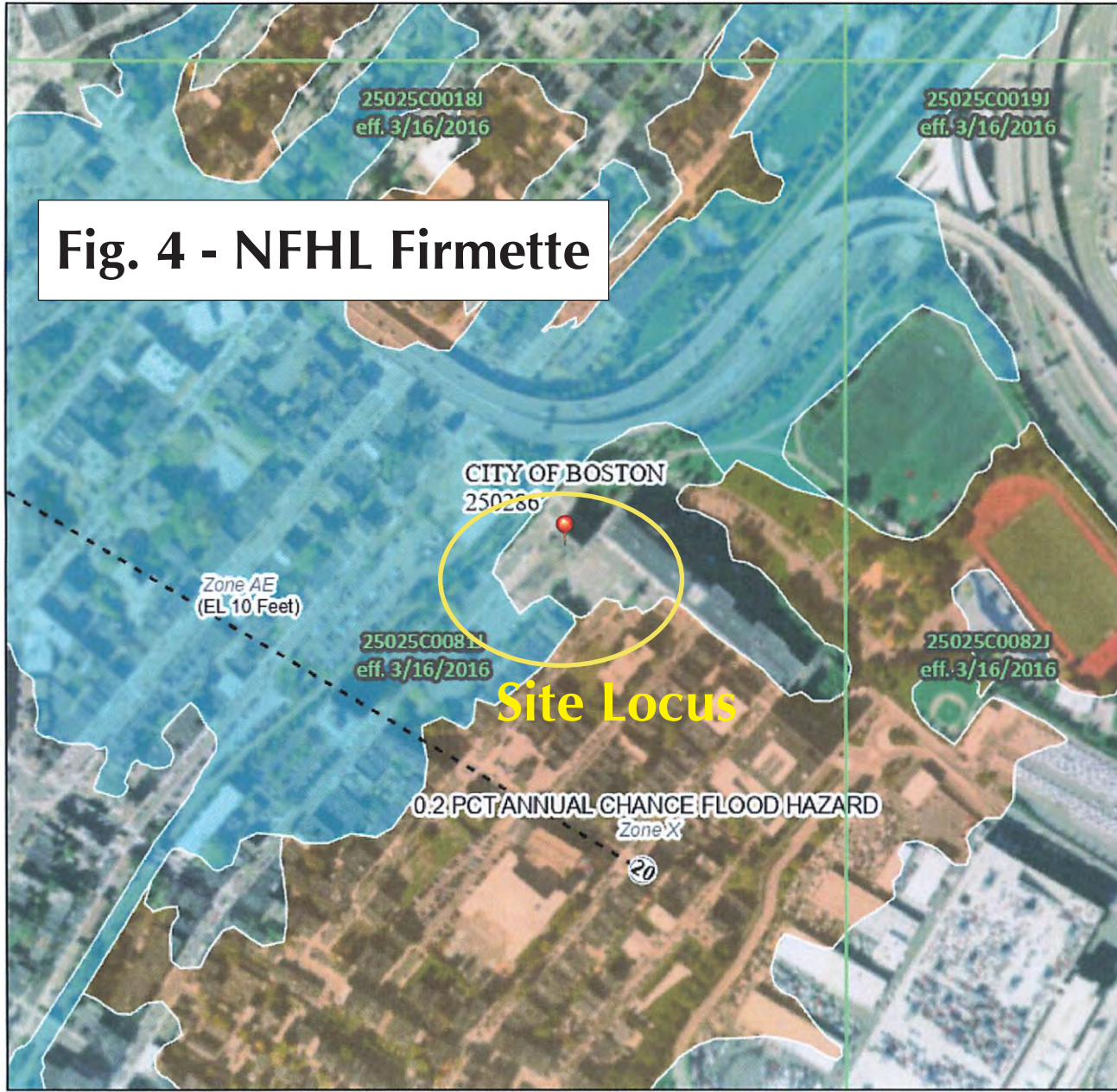

Fig. 4 - NFHL Firmette

Legend

SEE FIS REPORT FOR DETAILED LEGEND AND INDEX MAP FOR FIRM PANEL LAYOUT

- | | | |
|-----------------------------|--|--|
| SPECIAL FLOOD HAZARD AREAS | | Without Base Flood Elevation (BFE)
Zone A, V, A99 |
| | | With BFE or Depth Zone AE, AO, AH, VE, AR |
| | | Regulatory Floodway |
| OTHER AREAS OF FLOOD HAZARD | | 0.2% Annual Chance Flood Hazard, Area of 1% annual chance flood with average depth less than one foot or with drainage areas of less than one square mile Zone J |
| | | Future Conditions 1% Annual Chance Flood Hazard Zone X |
| | | Area with Reduced Flood Risk due to Levee. See Notes, Zone X |
| | | Area with Flood Risk due to Levee Zone D |
| OTHER AREAS | | NO SCREEN Area of Minimal Flood Hazard Zone X |
| | | Effective LOMRs |
| GENERAL STRUCTURES | | Area of Undetermined Flood Hazard Zone |
| | | Channel, Culvert, or Storm Sewer |
| | | Levee, Dike, or Floodwall |
| OTHER FEATURES | | 20.2
17.5
Cross Sections with 1% Annual Chance Water Surface Elevation |
| | | Coastal Transect |
| | | Base Flood Elevation Line (BFE) |
| | | Limit of Study |
| | | Jurisdiction Boundary |
| | | Coastal Transect Baseline |
| MAP PANELS | | Digital Data Available |
| | | No Digital Data Available |
| | | Unmapped |

The pin displayed on the map is an approximate point selected by the user and does not represent an authoritative property location.

Site Locus by Ivas Environmental - 16 May 21

This map complies with FEMA's standards for the use of digital flood maps if it is not void as described below. The basemap shown complies with FEMA's basemap accuracy standards

The flood hazard information is derived directly from the authoritative NFHL web services provided by FEMA. This map was exported on 5/16/2021 at 11:44 AM and does not reflect changes or amendments subsequent to this date and time. The NFHL and effective information may change or become superseded by new data over time.

This map image is void if the one or more of the following map elements do not appear: basemap imagery, flood zone labels, legend, scale bar, map creation date, community identifiers, FIRM panel number, and FIRM effective date. Map images for unmapped and unmodernized areas cannot be used for regulatory purposes.



United States
Department of
Agriculture

NRCS

Natural
Resources
Conservation
Service

A product of the National
Cooperative Soil Survey,
a joint effort of the United
States Department of
Agriculture and other
Federal agencies, State
agencies including the
Agricultural Experiment
Stations, and local
participants

Custom Soil Resource Report for Norfolk and Suffolk Counties, Massachusetts

Area Around 155 Porter St., East
Boston MA

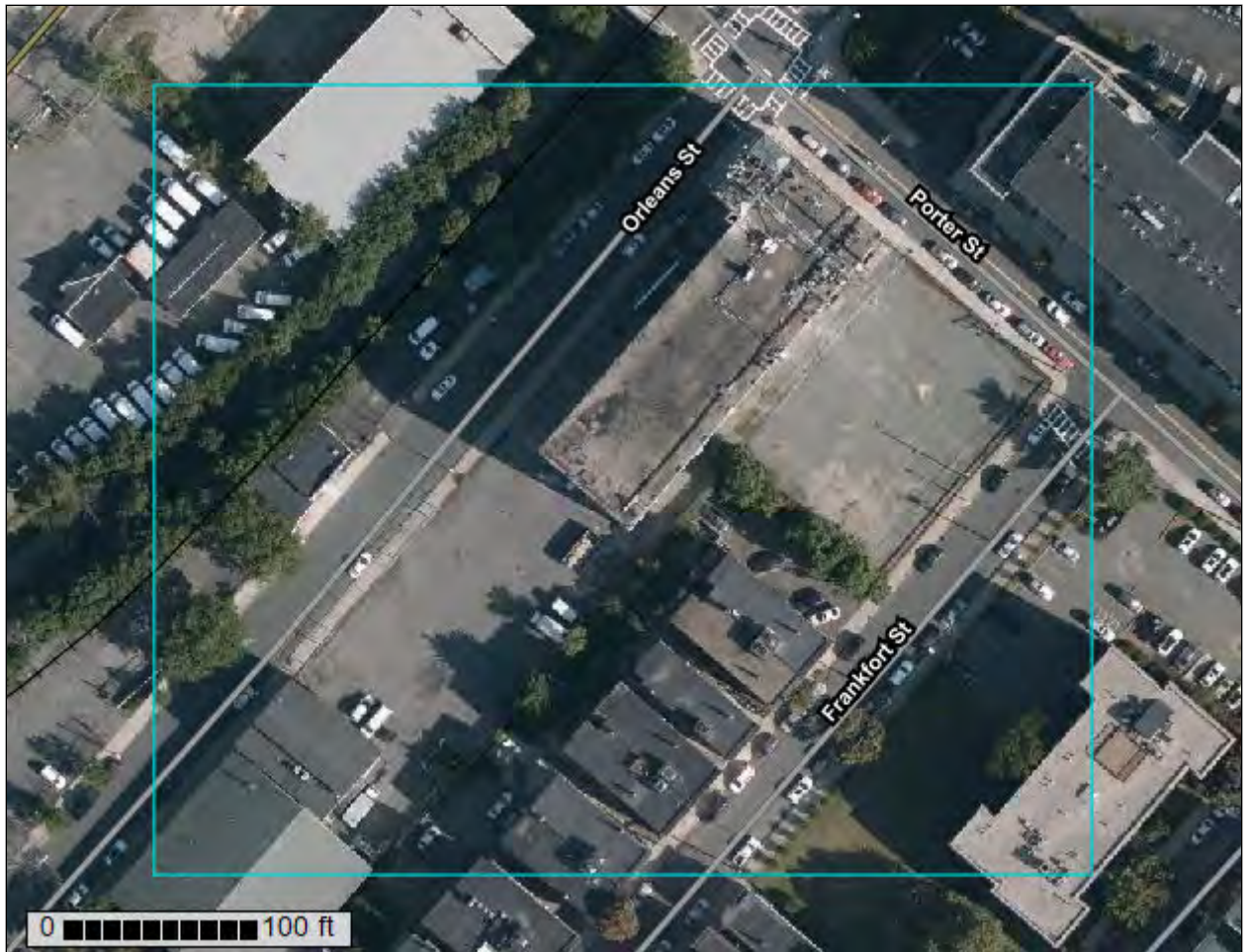

Preface

Soil surveys contain information that affects land use planning in survey areas. They highlight soil limitations that affect various land uses and provide information about the properties of the soils in the survey areas. Soil surveys are designed for many different users, including farmers, ranchers, foresters, agronomists, urban planners, community officials, engineers, developers, builders, and home buyers. Also, conservationists, teachers, students, and specialists in recreation, waste disposal, and pollution control can use the surveys to help them understand, protect, or enhance the environment.

Various land use regulations of Federal, State, and local governments may impose special restrictions on land use or land treatment. Soil surveys identify soil properties that are used in making various land use or land treatment decisions. The information is intended to help the land users identify and reduce the effects of soil limitations on various land uses. The landowner or user is responsible for identifying and complying with existing laws and regulations.

Although soil survey information can be used for general farm, local, and wider area planning, onsite investigation is needed to supplement this information in some cases. Examples include soil quality assessments (<http://www.nrcs.usda.gov/wps/portal/nrcs/main/soils/health/>) and certain conservation and engineering applications. For more detailed information, contact your local USDA Service Center (<https://offices.sc.egov.usda.gov/locator/app?agency=nrcs>) or your NRCS State Soil Scientist (http://www.nrcs.usda.gov/wps/portal/nrcs/detail/soils/contactus/?cid=nrcs142p2_053951).

Great differences in soil properties can occur within short distances. Some soils are seasonally wet or subject to flooding. Some are too unstable to be used as a foundation for buildings or roads. Clayey or wet soils are poorly suited to use as septic tank absorption fields. A high water table makes a soil poorly suited to basements or underground installations.

The National Cooperative Soil Survey is a joint effort of the United States Department of Agriculture and other Federal agencies, State agencies including the Agricultural Experiment Stations, and local agencies. The Natural Resources Conservation Service (NRCS) has leadership for the Federal part of the National Cooperative Soil Survey.

Information about soils is updated periodically. Updated information is available through the NRCS Web Soil Survey, the site for official soil survey information.

The U.S. Department of Agriculture (USDA) prohibits discrimination in all its programs and activities on the basis of race, color, national origin, age, disability, and where applicable, sex, marital status, familial status, parental status, religion, sexual orientation, genetic information, political beliefs, reprisal, or because all or a part of an individual's income is derived from any public assistance program. (Not all prohibited bases apply to all programs.) Persons with disabilities who require

alternative means for communication of program information (Braille, large print, audiotape, etc.) should contact USDA's TARGET Center at (202) 720-2600 (voice and TDD). To file a complaint of discrimination, write to USDA, Director, Office of Civil Rights, 1400 Independence Avenue, S.W., Washington, D.C. 20250-9410 or call (800) 795-3272 (voice) or (202) 720-6382 (TDD). USDA is an equal opportunity provider and employer.

Contents

Preface	2
How Soil Surveys Are Made	5
Soil Map	8
Soil Map.....	9
Legend.....	10
Map Unit Legend.....	11
Map Unit Descriptions.....	11
Norfolk and Suffolk Counties, Massachusetts.....	13
603—Urban land, wet substratum, 0 to 3 percent slopes.....	13
655—Udorthents, wet substratum.....	13
References	15

How Soil Surveys Are Made

Soil surveys are made to provide information about the soils and miscellaneous areas in a specific area. They include a description of the soils and miscellaneous areas and their location on the landscape and tables that show soil properties and limitations affecting various uses. Soil scientists observed the steepness, length, and shape of the slopes; the general pattern of drainage; the kinds of crops and native plants; and the kinds of bedrock. They observed and described many soil profiles. A soil profile is the sequence of natural layers, or horizons, in a soil. The profile extends from the surface down into the unconsolidated material in which the soil formed or from the surface down to bedrock. The unconsolidated material is devoid of roots and other living organisms and has not been changed by other biological activity.

Currently, soils are mapped according to the boundaries of major land resource areas (MLRAs). MLRAs are geographically associated land resource units that share common characteristics related to physiography, geology, climate, water resources, soils, biological resources, and land uses (USDA, 2006). Soil survey areas typically consist of parts of one or more MLRA.

The soils and miscellaneous areas in a survey area occur in an orderly pattern that is related to the geology, landforms, relief, climate, and natural vegetation of the area. Each kind of soil and miscellaneous area is associated with a particular kind of landform or with a segment of the landform. By observing the soils and miscellaneous areas in the survey area and relating their position to specific segments of the landform, a soil scientist develops a concept, or model, of how they were formed. Thus, during mapping, this model enables the soil scientist to predict with a considerable degree of accuracy the kind of soil or miscellaneous area at a specific location on the landscape.

Commonly, individual soils on the landscape merge into one another as their characteristics gradually change. To construct an accurate soil map, however, soil scientists must determine the boundaries between the soils. They can observe only a limited number of soil profiles. Nevertheless, these observations, supplemented by an understanding of the soil-vegetation-landscape relationship, are sufficient to verify predictions of the kinds of soil in an area and to determine the boundaries.

Soil scientists recorded the characteristics of the soil profiles that they studied. They noted soil color, texture, size and shape of soil aggregates, kind and amount of rock fragments, distribution of plant roots, reaction, and other features that enable them to identify soils. After describing the soils in the survey area and determining their properties, the soil scientists assigned the soils to taxonomic classes (units). Taxonomic classes are concepts. Each taxonomic class has a set of soil characteristics with precisely defined limits. The classes are used as a basis for comparison to classify soils systematically. Soil taxonomy, the system of taxonomic classification used in the United States, is based mainly on the kind and character of soil properties and the arrangement of horizons within the profile. After the soil

Custom Soil Resource Report

scientists classified and named the soils in the survey area, they compared the individual soils with similar soils in the same taxonomic class in other areas so that they could confirm data and assemble additional data based on experience and research.

The objective of soil mapping is not to delineate pure map unit components; the objective is to separate the landscape into landforms or landform segments that have similar use and management requirements. Each map unit is defined by a unique combination of soil components and/or miscellaneous areas in predictable proportions. Some components may be highly contrasting to the other components of the map unit. The presence of minor components in a map unit in no way diminishes the usefulness or accuracy of the data. The delineation of such landforms and landform segments on the map provides sufficient information for the development of resource plans. If intensive use of small areas is planned, onsite investigation is needed to define and locate the soils and miscellaneous areas.

Soil scientists make many field observations in the process of producing a soil map. The frequency of observation is dependent upon several factors, including scale of mapping, intensity of mapping, design of map units, complexity of the landscape, and experience of the soil scientist. Observations are made to test and refine the soil-landscape model and predictions and to verify the classification of the soils at specific locations. Once the soil-landscape model is refined, a significantly smaller number of measurements of individual soil properties are made and recorded. These measurements may include field measurements, such as those for color, depth to bedrock, and texture, and laboratory measurements, such as those for content of sand, silt, clay, salt, and other components. Properties of each soil typically vary from one point to another across the landscape.

Observations for map unit components are aggregated to develop ranges of characteristics for the components. The aggregated values are presented. Direct measurements do not exist for every property presented for every map unit component. Values for some properties are estimated from combinations of other properties.

While a soil survey is in progress, samples of some of the soils in the area generally are collected for laboratory analyses and for engineering tests. Soil scientists interpret the data from these analyses and tests as well as the field-observed characteristics and the soil properties to determine the expected behavior of the soils under different uses. Interpretations for all of the soils are field tested through observation of the soils in different uses and under different levels of management. Some interpretations are modified to fit local conditions, and some new interpretations are developed to meet local needs. Data are assembled from other sources, such as research information, production records, and field experience of specialists. For example, data on crop yields under defined levels of management are assembled from farm records and from field or plot experiments on the same kinds of soil.

Predictions about soil behavior are based not only on soil properties but also on such variables as climate and biological activity. Soil conditions are predictable over long periods of time, but they are not predictable from year to year. For example, soil scientists can predict with a fairly high degree of accuracy that a given soil will have a high water table within certain depths in most years, but they cannot predict that a high water table will always be at a specific level in the soil on a specific date.

After soil scientists located and identified the significant natural bodies of soil in the survey area, they drew the boundaries of these bodies on aerial photographs and

Custom Soil Resource Report

identified each as a specific map unit. Aerial photographs show trees, buildings, fields, roads, and rivers, all of which help in locating boundaries accurately.

Soil Map

The soil map section includes the soil map for the defined area of interest, a list of soil map units on the map and extent of each map unit, and cartographic symbols displayed on the map. Also presented are various metadata about data used to produce the map, and a description of each soil map unit.

Custom Soil Resource Report Soil Map

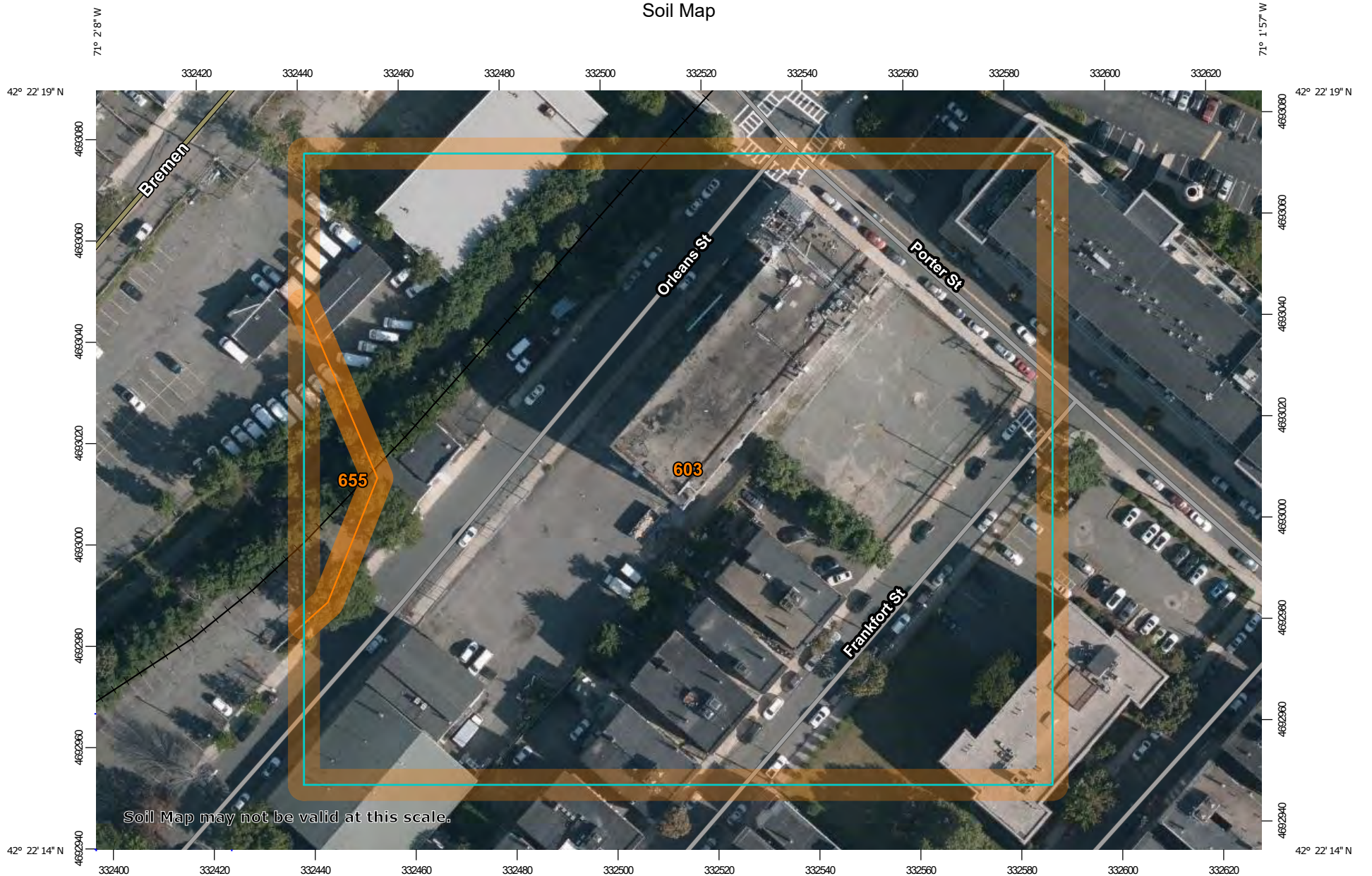

Map Scale: 1:1,060 if printed on A landscape (11" x 8.5") sheet.

0 15 30 60 90 Meters

0 50 100 200 300 Feet

Map projection: Web Mercator Corner coordinates: WGS84 Edge ticks: UTM Zone 19N WGS84

MAP LEGEND

Area of Interest (AOI)

 Area of Interest (AOI)

Soils

 Soil Map Unit Polygons

 Soil Map Unit Lines

 Soil Map Unit Points

Special Point Features

 Blowout

 Borrow Pit

 Clay Spot

 Closed Depression

 Gravel Pit

 Gravelly Spot

 Landfill

 Lava Flow

 Marsh or swamp

 Mine or Quarry

 Miscellaneous Water

 Perennial Water

 Rock Outcrop

 Saline Spot

 Sandy Spot

 Severely Eroded Spot

 Sinkhole

 Slide or Slip

 Sodic Spot

 Spoil Area

 Stony Spot

 Very Stony Spot

 Wet Spot

 Other

 Special Line Features

Water Features

 Streams and Canals

Transportation

 Rails

 Interstate Highways

 US Routes

 Major Roads

 Local Roads

Background

 Aerial Photography

MAP INFORMATION

The soil surveys that comprise your AOI were mapped at 1:25,000.

Warning: Soil Map may not be valid at this scale.

Enlargement of maps beyond the scale of mapping can cause misunderstanding of the detail of mapping and accuracy of soil line placement. The maps do not show the small areas of contrasting soils that could have been shown at a more detailed scale.

Please rely on the bar scale on each map sheet for map measurements.

Source of Map: Natural Resources Conservation Service
 Web Soil Survey URL:
 Coordinate System: Web Mercator (EPSG:3857)

Maps from the Web Soil Survey are based on the Web Mercator projection, which preserves direction and shape but distorts distance and area. A projection that preserves area, such as the Albers equal-area conic projection, should be used if more accurate calculations of distance or area are required.

This product is generated from the USDA-NRCS certified data as of the version date(s) listed below.

Soil Survey Area: Norfolk and Suffolk Counties, Massachusetts
 Survey Area Data: Version 16, Jun 11, 2020

Soil map units are labeled (as space allows) for map scales 1:50,000 or larger.

Date(s) aerial images were photographed: Sep 11, 2019—Oct 5, 2019

The orthophoto or other base map on which the soil lines were compiled and digitized probably differs from the background imagery displayed on these maps. As a result, some minor shifting of map unit boundaries may be evident.

Map Unit Legend

Map Unit Symbol	Map Unit Name	Acres in AOI	Percent of AOI
603	Urban land, wet substratum, 0 to 3 percent slopes	4.5	97.3%
655	Udortheents, wet substratum	0.1	2.7%
Totals for Area of Interest		4.6	100.0%

Map Unit Descriptions

The map units delineated on the detailed soil maps in a soil survey represent the soils or miscellaneous areas in the survey area. The map unit descriptions, along with the maps, can be used to determine the composition and properties of a unit.

A map unit delineation on a soil map represents an area dominated by one or more major kinds of soil or miscellaneous areas. A map unit is identified and named according to the taxonomic classification of the dominant soils. Within a taxonomic class there are precisely defined limits for the properties of the soils. On the landscape, however, the soils are natural phenomena, and they have the characteristic variability of all natural phenomena. Thus, the range of some observed properties may extend beyond the limits defined for a taxonomic class. Areas of soils of a single taxonomic class rarely, if ever, can be mapped without including areas of other taxonomic classes. Consequently, every map unit is made up of the soils or miscellaneous areas for which it is named and some minor components that belong to taxonomic classes other than those of the major soils.

Most minor soils have properties similar to those of the dominant soil or soils in the map unit, and thus they do not affect use and management. These are called noncontrasting, or similar, components. They may or may not be mentioned in a particular map unit description. Other minor components, however, have properties and behavioral characteristics divergent enough to affect use or to require different management. These are called contrasting, or dissimilar, components. They generally are in small areas and could not be mapped separately because of the scale used. Some small areas of strongly contrasting soils or miscellaneous areas are identified by a special symbol on the maps. If included in the database for a given area, the contrasting minor components are identified in the map unit descriptions along with some characteristics of each. A few areas of minor components may not have been observed, and consequently they are not mentioned in the descriptions, especially where the pattern was so complex that it was impractical to make enough observations to identify all the soils and miscellaneous areas on the landscape.

The presence of minor components in a map unit in no way diminishes the usefulness or accuracy of the data. The objective of mapping is not to delineate pure taxonomic classes but rather to separate the landscape into landforms or landform segments that have similar use and management requirements. The delineation of such segments on the map provides sufficient information for the development of resource plans. If intensive use of small areas is planned, however,

Custom Soil Resource Report

onsite investigation is needed to define and locate the soils and miscellaneous areas.

An identifying symbol precedes the map unit name in the map unit descriptions. Each description includes general facts about the unit and gives important soil properties and qualities.

Soils that have profiles that are almost alike make up a *soil series*. Except for differences in texture of the surface layer, all the soils of a series have major horizons that are similar in composition, thickness, and arrangement.

Soils of one series can differ in texture of the surface layer, slope, stoniness, salinity, degree of erosion, and other characteristics that affect their use. On the basis of such differences, a soil series is divided into *soil phases*. Most of the areas shown on the detailed soil maps are phases of soil series. The name of a soil phase commonly indicates a feature that affects use or management. For example, Alpha silt loam, 0 to 2 percent slopes, is a phase of the Alpha series.

Some map units are made up of two or more major soils or miscellaneous areas. These map units are complexes, associations, or undifferentiated groups.

A *complex* consists of two or more soils or miscellaneous areas in such an intricate pattern or in such small areas that they cannot be shown separately on the maps. The pattern and proportion of the soils or miscellaneous areas are somewhat similar in all areas. Alpha-Beta complex, 0 to 6 percent slopes, is an example.

An *association* is made up of two or more geographically associated soils or miscellaneous areas that are shown as one unit on the maps. Because of present or anticipated uses of the map units in the survey area, it was not considered practical or necessary to map the soils or miscellaneous areas separately. The pattern and relative proportion of the soils or miscellaneous areas are somewhat similar. Alpha-Beta association, 0 to 2 percent slopes, is an example.

An *undifferentiated group* is made up of two or more soils or miscellaneous areas that could be mapped individually but are mapped as one unit because similar interpretations can be made for use and management. The pattern and proportion of the soils or miscellaneous areas in a mapped area are not uniform. An area can be made up of only one of the major soils or miscellaneous areas, or it can be made up of all of them. Alpha and Beta soils, 0 to 2 percent slopes, is an example.

Some surveys include *miscellaneous areas*. Such areas have little or no soil material and support little or no vegetation. Rock outcrop is an example.

Norfolk and Suffolk Counties, Massachusetts

603—Urban land, wet substratum, 0 to 3 percent slopes

Map Unit Setting

National map unit symbol: vkyl
Mean annual precipitation: 32 to 50 inches
Mean annual air temperature: 45 to 50 degrees F
Frost-free period: 120 to 200 days
Farmland classification: Not prime farmland

Map Unit Composition

Urban land: 85 percent
Minor components: 15 percent
Estimates are based on observations, descriptions, and transects of the mapunit.

Description of Urban Land

Setting

Parent material: Excavated and filled land over herbaceous organic material and/or alluvium and/or marine deposits

Minor Components

Udorthents

Percent of map unit: 13 percent
Hydric soil rating: Unranked

Beaches

Percent of map unit: 2 percent
Hydric soil rating: Unranked

655—Udorthents, wet substratum

Map Unit Setting

National map unit symbol: vkyl
Elevation: -30 to 310 feet
Mean annual precipitation: 45 to 54 inches
Mean annual air temperature: 43 to 54 degrees F
Frost-free period: 145 to 240 days
Farmland classification: Not prime farmland

Map Unit Composition

Udorthents and similar soils: 95 percent
Minor components: 5 percent
Estimates are based on observations, descriptions, and transects of the mapunit.

Description of Udorthents

Setting

Landform position (two-dimensional): Foothlope, shoulder

Landform position (three-dimensional): Tread, riser

Down-slope shape: Linear, convex

Across-slope shape: Linear, convex

Parent material: Excavated and filled sandy and gravelly human transported material over highly-decomposed herbaceous organic material

Properties and qualities

Slope: 0 to 3 percent

Depth to restrictive feature: More than 80 inches

Depth to water table: More than 80 inches

Frequency of flooding: None

Frequency of ponding: None

Minor Components

Urban land

Percent of map unit: 3 percent

Hydric soil rating: Unranked

Ipswich

Percent of map unit: 2 percent

Landform: Marshes

Hydric soil rating: Yes

References

- American Association of State Highway and Transportation Officials (AASHTO). 2004. Standard specifications for transportation materials and methods of sampling and testing. 24th edition.
- American Society for Testing and Materials (ASTM). 2005. Standard classification of soils for engineering purposes. ASTM Standard D2487-00.
- Cowardin, L.M., V. Carter, F.C. Golet, and E.T. LaRoe. 1979. Classification of wetlands and deep-water habitats of the United States. U.S. Fish and Wildlife Service FWS/OBS-79/31.
- Federal Register. July 13, 1994. Changes in hydric soils of the United States.
- Federal Register. September 18, 2002. Hydric soils of the United States.
- Hurt, G.W., and L.M. Vasilas, editors. Version 6.0, 2006. Field indicators of hydric soils in the United States.
- National Research Council. 1995. Wetlands: Characteristics and boundaries.
- Soil Survey Division Staff. 1993. Soil survey manual. Soil Conservation Service. U.S. Department of Agriculture Handbook 18. http://www.nrcs.usda.gov/wps/portal/nrcs/detail/national/soils/?cid=nrcs142p2_054262
- Soil Survey Staff. 1999. Soil taxonomy: A basic system of soil classification for making and interpreting soil surveys. 2nd edition. Natural Resources Conservation Service, U.S. Department of Agriculture Handbook 436. http://www.nrcs.usda.gov/wps/portal/nrcs/detail/national/soils/?cid=nrcs142p2_053577
- Soil Survey Staff. 2010. Keys to soil taxonomy. 11th edition. U.S. Department of Agriculture, Natural Resources Conservation Service. http://www.nrcs.usda.gov/wps/portal/nrcs/detail/national/soils/?cid=nrcs142p2_053580
- Tiner, R.W., Jr. 1985. Wetlands of Delaware. U.S. Fish and Wildlife Service and Delaware Department of Natural Resources and Environmental Control, Wetlands Section.
- United States Army Corps of Engineers, Environmental Laboratory. 1987. Corps of Engineers wetlands delineation manual. Waterways Experiment Station Technical Report Y-87-1.
- United States Department of Agriculture, Natural Resources Conservation Service. National forestry manual. http://www.nrcs.usda.gov/wps/portal/nrcs/detail/soils/home/?cid=nrcs142p2_053374
- United States Department of Agriculture, Natural Resources Conservation Service. National range and pasture handbook. <http://www.nrcs.usda.gov/wps/portal/nrcs/detail/national/landuse/rangepasture/?cid=stelprdb1043084>

Custom Soil Resource Report

United States Department of Agriculture, Natural Resources Conservation Service. National soil survey handbook, title 430-VI. http://www.nrcs.usda.gov/wps/portal/nrcs/detail/soils/scientists/?cid=nrcs142p2_054242

United States Department of Agriculture, Natural Resources Conservation Service. 2006. Land resource regions and major land resource areas of the United States, the Caribbean, and the Pacific Basin. U.S. Department of Agriculture Handbook 296. http://www.nrcs.usda.gov/wps/portal/nrcs/detail/national/soils/?cid=nrcs142p2_053624

United States Department of Agriculture, Soil Conservation Service. 1961. Land capability classification. U.S. Department of Agriculture Handbook 210. http://www.nrcs.usda.gov/Internet/FSE_DOCUMENTS/nrcs142p2_052290.pdf

Exhibit C - List of Plans - 155 Porter Street, East Boston - 15 Jul 21

Plan #	Description	Date	Scale
PL100	Parcel Plan - Issued for Permit	26 Nov 19	1 in = 20 ft
None	Site Plan - Land in Boston	06 Apr 17	1 in = 16 ft
C100	Site Preparation Plan - Hotel Redevelopment	26 Nov 19	1 in = 20 ft
C101	Layout and Materials Plan - Hotel Redevelopment	20 Nov 20	1 in = 20 ft
C102	Grading and Utility Plan - Hotel Redevelopment	02 Jan 20	1 in = 20 ft
C103	Truck Turning Movements - Hotel Redevelopment	02 Jan 20	1 in = 20 ft
C201	Profiles and Details - Hotel Redevelopment	26 Nov 19	1 in = 20 ft
C202	Details - Hotel Redevelopment	26 Nov 19	1 in = 20 ft
C203	Details - Hotel Redevelopment	26 Nov 19	1 in = 20 ft
C204	Details - Hotel Redevelopment	26 Nov 19	1 in = 20 ft
L101	Landscape Plan, Notes, Details & Schedule	09 Jan 21	1 in = 40 ft
L201	Green Roof Landscape Details	09 Jun 21	Varies

All Plans for: Hotel Redevelopment, 155 Porter St., East Boston MA

Applicant: Hudson 62 Realty, LLC, 440 Bedford St., Lexington MA 01824

Site Plan: Anderson Surveys, Inc., 80 High St., Hanson MA 02341-0149

Civil Plans: PVI Site Design, LLC, 339.206.1030

Landscape Plan: RBLA DESIGN LLC, 781.686.4486

155 Porter St - Hotel Redevelopment

Abutters Mailing List Method - 06 Jun 21

Since there were over 900 abutters to the three parcels, and many were abutters of all three parcels, a method was developed to provide a unique list of abutters for all three parcels as follows:

1. Each of the abutters lists for the three parcels was output as an Microsoft Excel File.
2. The three files were combined into one address Master File.
3. The duplicate abutters were eliminated from the Master File. The result was 320 unique abutter mailing addresses.
4. The leading zeros for the ZIP codes were added to the address field.
5. Envelope labels were printed from the Master File in Microsoft Excel.
6. The Certificates of Mailing form (USPS 3877) was imported into Adobe InDesign.
7. The Master File was used the source for a data merge to print addresses onto facsimiles of the USPS Form 3877.

(Each of these forms provides for eight (8) addresses. Therefore, there are 40 USPS 3877 Certificates of Mailing Forms. Once the abutters' notifications in English, Spanish, and the Babel cards are mailed, copies of the forms shall be forwarded to the City of Boston Conservation Commission.)

8. The following pages include the three City of Boston abutter mailing list generated graphics for each of the three parcels, and a copy of the 320 mailing labels.

[COVID-19 INFORMATION \(HTTPS://WWW.BOSTON.GOV/NEWS/CORONAVIRUS-DISEASE-COVID-19-BOSTON\)](https://www.boston.gov/news/coronavirus-disease-covid-19-boston)

ABUTTER MAILING LIST GENERATOR

Search for an address or enter a parcel ID below.

ADDRESS SEARCH

Search for an address

PARCEL SEARCH

0103927000

SEARCH

SELECTED PARCEL

103927000 - undefined

Enter a buffer distance and a the mailing list csv will appear below.

BUFFER DISTANCE (FEET)

300

BUFFER PARCEL

[DOWNLOAD MAILING LIST](#) [WWW.BO](#)

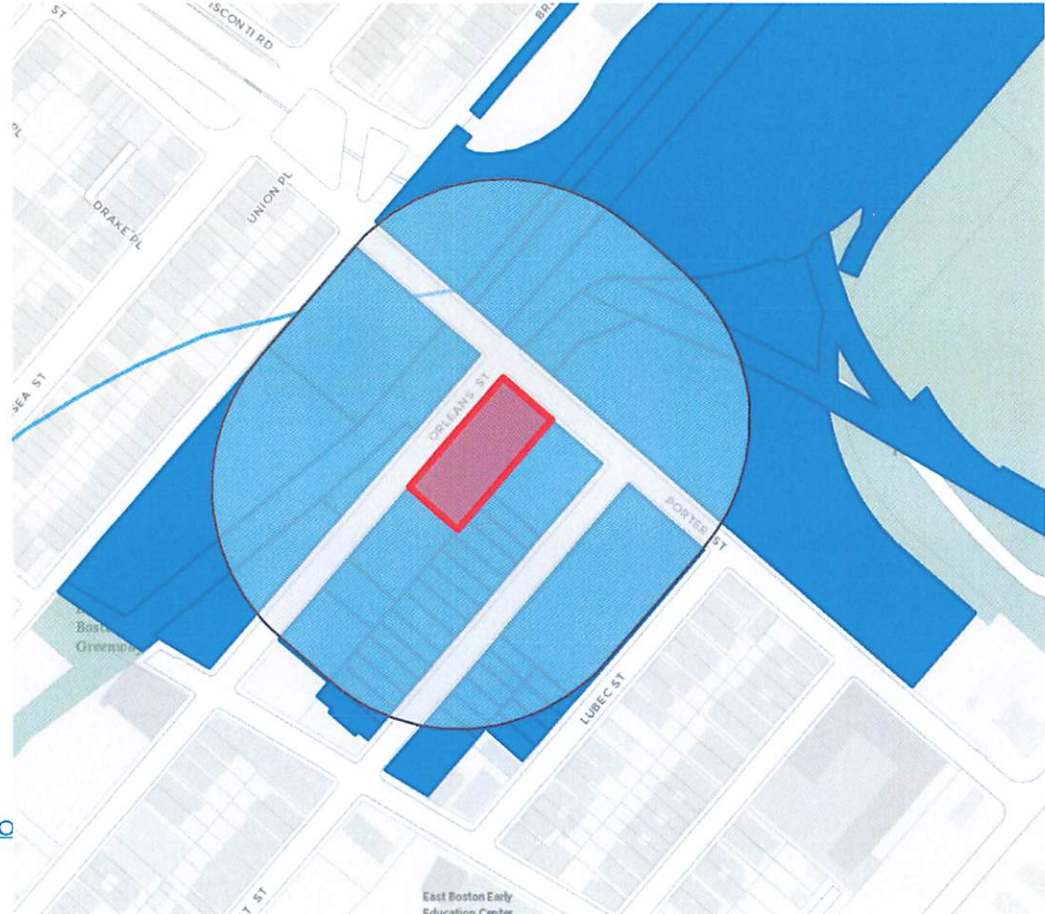

[COVID-19 INFORMATION \(HTTPS://WWW.BOSTON.GOV/NEWS/CORONAVIRUS-DISEASE-COVID-19-BOSTON\)](https://www.boston.gov/news/coronavirus-disease-covid-19-boston)

ABUTTER MAILING LIST GENERATOR

Search for an address or enter a parcel ID below.

ADDRESS SEARCH

Search for an address

PARCEL SEARCH

0103928000

SEARCH

SELECTED PARCEL

103928000 - undefined

Enter a buffer distance and a the mailing list csv will appear below.

BUFFER DISTANCE (FEET)

300

BUFFER PARCEL

[DOWNLOAD MAILING LIST](#)

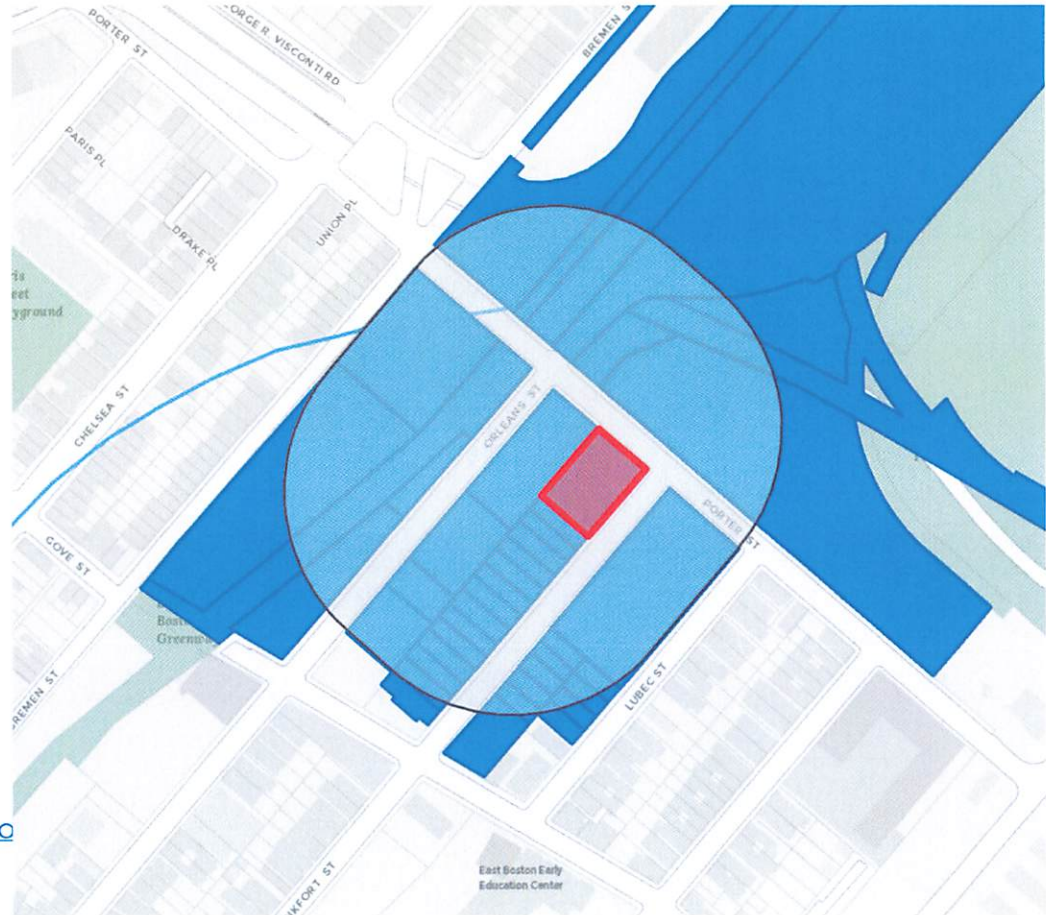

BACK TO TOP

[COVID-19 INFORMATION \(HTTPS://WWW.BOSTON.GOV/NEWS/CORONAVIRUS-DISEASE-COVID-19-BOSTON\)](https://www.boston.gov/news/coronavirus-disease-covid-19-boston)

ABUTTER MAILING LIST GENERATOR

Search for an address or enter a parcel ID below.

ADDRESS SEARCH

PARCEL SEARCH

SEARCH

SELECTED PARCEL

103926000 - undefined

Enter a buffer distance and the mailing list csv will appear below.

BUFFER DISTANCE (FEET)

BUFFER PARCEL

[DOWNLOAD Mailing List CSV](https://www.boston.gov/abutter-mailing-list-generator)

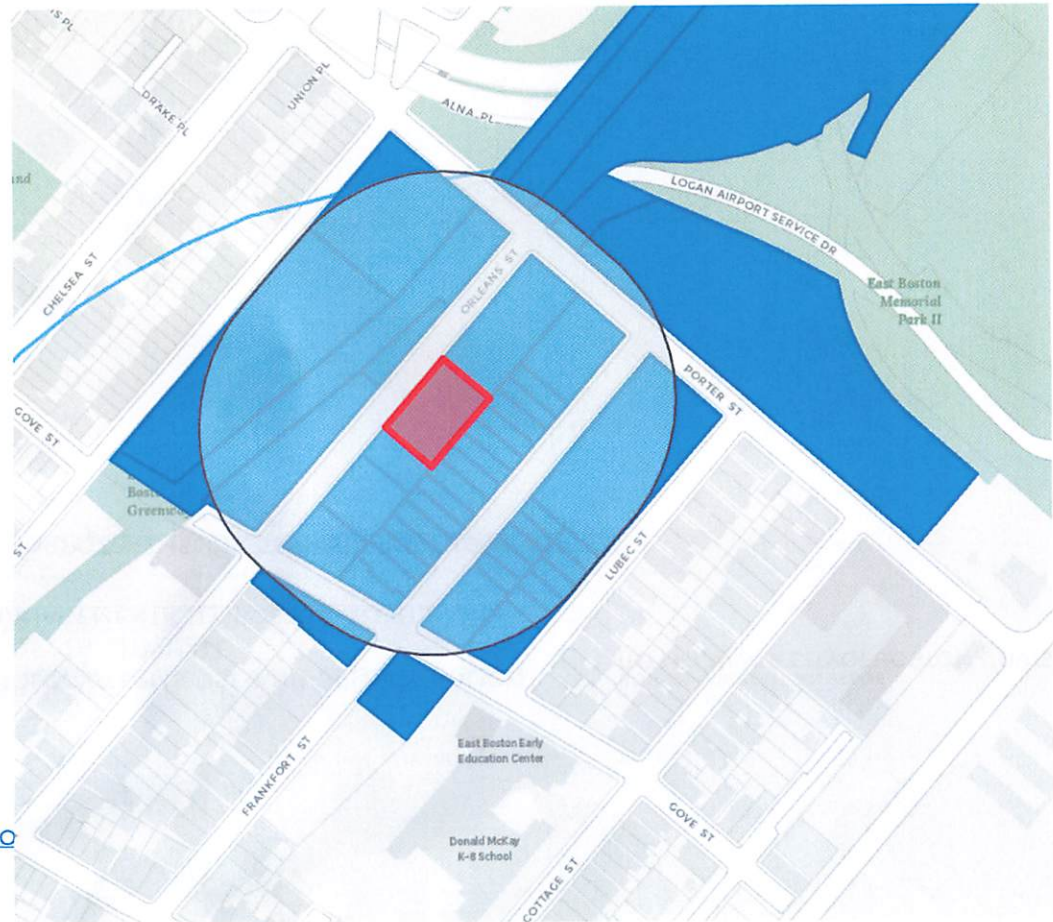

[PRIVACY POLICY \(/DEPARTMENTS/INNOVATION-AND-TECHNOLOGY/TERMS-USE-AND-PRIVACY-POLICY\)](/DEPARTMENTS/INNOVATION-AND-TECHNOLOGY/TERMS-USE-AND-PRIVACY-POLICY)

[CONTACT US \(/DEPARTMENTS/MAYORS-OFFICE/CONTACT-BOSTON-CITY-HALL\)](/DEPARTMENTS/MAYORS-OFFICE/CONTACT-BOSTON-CITY-HALL)

[ALERTS AND NOTIFICATIONS \(/DEPARTMENTS/EMERGENCY-MANAGEMENT/CITY-BOSTON-ALERTS-AND-NOTIFICATIONS\)](/DEPARTMENTS/EMERGENCY-MANAGEMENT/CITY-BOSTON-ALERTS-AND-NOTIFICATIONS)

[PUBLIC RECORDS REQUESTS](#)

[HTTPS://BOSTONMA.GOVQA.US/WEBAPP/_RS/\(S\(DEN310HNRPQZ2RZH5LGBGSBY\)\)/SUPPORTHOME.ASPX\)](HTTPS://BOSTONMA.GOVQA.US/WEBAPP/_RS/(S(DEN310HNRPQZ2RZH5LGBGSBY))/SUPPORTHOME.ASPX)

BOS:311 - REPORT AN ISSUE
[\(HTTP://WWW.CITYOFBOSTON.GOV/311/\)](HTTP://WWW.CITYOFBOSTON.GOV/311/)



TEPIC SLOBODAN
156 PORTER ST # 249
EAST BOSTON MA 02128

CASEY CHRISTOPHER J
156 PORTER ST # 324
EAST BOSTON MA 02128

ROUNSEVILLE CULLEN
156 PORTER ST #312
EAST BOSTON MA 02128

TAKDJERAD ABDENOUR
156 PORTER ST #316
EAST BOSTON MA 02128

MUNERA ANALIDA
156 PORTER ST #433
EAST BOSTON MA 02128

MORALES TELESFORO M
60 LUBEC ST
EAST BOSTON MA 02128

KENAWELL FRANCIS GREGORY
156 PORTER ST #355
EAST BOSTON MA 02128

MANOTAS ALBERTO MARIA
C/O DIANA COMERFORD-MOTA
EAST BOSTON MA 02128

CAMPANELLI JOSEPH
156 PORTER ST #340
EAST BOSTON MA 02128

BUIE ALLEN A
156 PORTER ST # 201
EAST BOSTON MA 02128

JACKSON-KINGSTON JEROME O
156 PORTER ST #253
EAST BOSTON MA 02128

EISENBERG SCOTT
156 PORTER ST #314
EAST BOSTON OR 02128

KOCH JOSEPH
156 PORTER ST #124
EAST BOSTON MA 02128

DEPATIE ANDREA M
156 PORTER ST #447
EAST BOSTON MA 02128

ELIA ALBERT
156 PORTER ST # 308
EAST BOSTON MA 02128

HENDERSON HOLLACE A
156 PORTER ST # 411
EAST BOSTON MA 02128

BECKER DAVID TS
156 PORTER ST #435
E BOSTON MA 02128

CHEUNG WAI YAN
156 PORTER ST # 150
EAST BOSTON MA 02128

DECHRISTOFORO JENNIFER LYNN
156 PORTER ST # 130
EAST BOSTON MA 02128

EAST BOSTON NEIGHBORHOOD
10 GOVE ST
EAST BOSTON MA 02128

LILLY-WEBER STEVEN
156 PORTER ST # 227
EAST BOSTON MA 02128

GADZA ELIZABETH
156 PORTER ST #351
EAST BOSTON MA 02128

BUTLER JOHN R
4 VINTON ST #2
SOUTH BOSTON MA 02127

FRANKFORT STREET IRREVOCABLE
TRUST
14 ARNOLD AV
READING MA 01867

AMIN SUSHIL
231 EAST MAIN STREET
WESTBORO MA 01581

HUDSON 62 REALTY LLC
83 HARTWELL AVE
LEXINGTON MA 02421

DE LA BRUERE COLLIN ROSS
64 Frankfort ST, Unit 3
EAST BOSTON MA 02128

COMMONWEALTH OF MASS
10 PARK PLZ RM 6160
BOSTON MA 02116

CARDONA FERRER AMANDA V
48 Frankfort ST, Unit 16
EAST BOSTON MA 02128

SIXTY 2 LUBEC ST CONDO TR
62 LUBEC
EAST BOSTON MA 02128

LEONG SHIN MON
72 LUBEC ST #14
EAST BOSTON MA 02128

58 FRANKFORT STREET LLC
1535 BEACON ST
NEWTON MA 02468

SOULE PETER BRADFORD
156 PORTER ST # 203
EAST BOSTON MA 02128

PHAM DUNG P
14 DIANES VIEW
MALDEN MA 02148

CHEN LEAH B
156 PORTER ST, Unit 123
EAST BOSTON MA 02128

HERMANN RICHARD
156 PORTER ST # 334
EAST BOSTON MA 02128

LARA RITA
156 PORTER ST # 151
EAST BOSTON MA 02128

NICRON LLC
PO BOX 53
EAST BOSTON MA 02128

ALPEREN DARA
99 GOVE ST #3
EAST BOSTON MA 02128

SUCH KYLE
156 PORTER ST # 238
EAST BOSTON MA 02128

TENNANT CARRIE
156 PORTER ST, Unit 414
BOSTON MA 02128

ZIMMERMAN NEIL LAWRENCE
156 PORTER ST, Unit 430
EAST BOSTON MA 02128

TERESO MARIA
156 PORTER ST #128
EAST BOSTON MA 02128

FRANKFORT GOVE LLC
220 BOYLSTON ST #1214
BOSTON MA 02116

JIANG SHI YU
156 PORTER ST, Unit 410
EAST BOSTON MA 02128

VARGAS ROBERTO
156 PORTER ST #416
EAST BOSTON MA 02128

ZULPS ALBERT
156 PORTER ST #417
EAST BOSTON MA 02128

AUCELLA RALPH
156 PORTER ST # 207
EAST BOSTON MA 02128

OCONNOR KELLY
10500 BEACH MILL RD
GREAT FALLS VA 22066

GUZMAN-VELEZ EDMARIE
156 PORTER ST #205
EAST BOSTON MA 02128

SULLIVAN KATIE A
156 PORTER ST #114
EAST BOSTON MA 02128

GILLESPIE BOSTON REALTY TRUST
156 PORTER ST #418
EAST BOSTON MA 02128

LUBEC STREET REALTY TRUST
72 LUBEC ST #21
EAST BOSTON MA 02128

BECKER CHRISTINA
156 PORTER ST #257
EAST BOSTON MA 02128

CURTIS JOSHUA
156 PORTER ST #103
EAST BOSTON MA 02128

SEGALES-PEREZ JORDI
156 PORTER ST, Unit 254
EAST BOSTON MA 02128

MOYES ALAN J
156 PORTER ST, Unit 441
EAST BOSTON MA 02128

FRANCKE MATTHEW
156 PORTER ST # 338
EAST BOSTON MA 02128

E BOSTON NEIGHBORHOOD HEALTH
10 GOVE ST
EAST BOSTON MA 02128

LAMATTINA BRIAN
156 PORTER ST # 218
EAST BOSTON MA 02128

66 LUBEC STREET LLC
1535 BEACON STREET
WABAN MA 02468

KACZOWKA CATHERINE
156 PORTER ST #122
EAST BOSTON MA 02128

EAST BOSTON NEIGHBORHOOD
10 GROVE ST
E BOSTON MA 02128

MORIN MATTHEW
64 Frankfort ST, Unit 5
EAST BOSTON MA 02128

OU GAOJIE
64 Frankfort ST, Unit 4
EAST BOSTON MA 02128

CHO YUN WAI
72 LUBEC ST, #7
EAST BOSTON MA 02128

LIBERATOS MICHAEL
156 PORTER ST # 304
EAST BOSTON MA 02128

SHOENBERGER JOHN
156 PORTER ST # 302
EAST BOSTON MA 02128

BOUTHILETTE MATTHEW
156 PORTER ST, Unit 149
EAST BOSTON MA 02128

PORTER STREET TRUST
16 INDUSTRIAL WAY
HANOVER MA 02339

BUENROSTRO BENJAMIN
71 FRANKFORT ST
EAST BOSTON MA 02128

BEHKAMI NIMA
156 PORTER ST # 423
EAST BOSTON MA 02128

STILING JOSHUA
156 PORTER ST, Unit 412
EAST BOSTON MA 02128

JENKINS SCOTT W
156 PORTER ST
EAST BOSTON MA 02128

ANDREW T PREAS LIVING TRUST
156 PORTER ST # 445
EAST BOSTON MA 02128

MALONE DANA
156 PORTER ST # 229
EAST BOSTON MA 02128

RABBITT KYLE
156 PORTER ST # 331
EAST BOSTON MA 02128

PAREEK RAJESH
65 E INDIA ROW #11G
BOSTON MA 02110

COPPOLA JANINE L
172 ENDICOTT ST
BOSTON MA 02113

ALLISON PHYLLIS
17 OLD HARBOR ST
SOUTH BOSTON MA 02127

JULIE C VAIL REVOCABLE TRUST
156 PORTER ST, Unit 323
EAST BOSTON MA 02128

BORISOVA JULIA
72 LUBEC ST, Unit 10
EAST BOSTON MA 02128

HENDRIX JAMES
99 GOVE ST
EAST BOSTON MA 02128

WINGROVE ROBERT
14 WATER ST
WOBURN MA 01801

CASERTA BIANCAMIRTO
72 LUBEC ST #16
EAST BOSTON MA 02128

KOZLOW MARTIN
156 PORTER ST # 131
EAST BOSTON MA 02128

JOHN P AUCELLA TRUST
156 PORTER ST, Unit 219
EAST BOSTON MA 02128

ABRAMKINA ANNA
156 PORTER ST #102
EAST BOSTON MA 02128

BLISS EMILY
62 LUBEC ST, Unit 301
EAST BOSTON MA 02128

DWORKIN FREDI E
156 PORTER ST # 110
EAST BOSTON MA 02128

DIPIETRO IRMA
74 FRANKFORT ST
EAST BOSTON MA 02128

HONC PAWEL
156 PORTER ST, Unit 141
EAST BOSTON MA 02128

LYDON LEONARD R
39 DOWNER AVENUE UNIT 2
BOSTON MA 02125

ONEILL SEAN M
67 FRANKFORT ST #302
EAST BOSTON MA 02128

LIVERMORE CARA L
156 PORTER ST # 317
EAST BOSTON MA 02128

JENKINS SCOTT W
21 CUSTOM HOUSE ST SUITE 700
BOSTON MA 02110

ROSSETTI ELENA
72 LUBEC ST, #3
EAST BOSTON MA 02128

SCOTT MILLER MARY
64 Frankfort ST, Unit 2
EAST BOSTON MA 02128

LAU JARRETT
156 PORTER ST #220
EAST BOSTON MA 02128

BERGSTRESSER MATTHEW L
156 PORTER ST #346
EAST BOSTON MA 02128

PREVITE PETER M
120 HOLMES ST #217E
QUINCY MA 02171

DINOCCO VINCENZA M
99 GROVE ST, Unit 9
EAST BOSTON MA 02128

MILLER MICHAEL J
882 MAIN ST
NORWELL MA 02061

DAVIS JIMMY JR
156 PORTER ST # 354
EAST BOSTON MA 02128

CITY OF BOSTON PARKS AND
ORLEANS ST
E BOSTON MA 02128

LACK JESSICA
156 PORTER ST #247
BOSTON MA 02128

BREED EDWARD M
20 CHESTNUT ST #407
CAMBRIDGE MA 02139

PURDY MICHAEL A
72 LUBEC ST #5
EAST BOSTON MA 02128

WHITE STEPHEN J
156 PORTER ST, Unit 139
EAST BOSTON MA 02128

WHITE ANTHONY F
743 15TH STREET #9
MIAMI BEACH MA 33139

MJG TRUST LLC
105 LONGVIEW DR
BRIDGEWATER MA 02324

BOIVIN MICHAEL
156 PORTER ST #348
EAST BOSTON MA 02128

EASON JEFFREY PAUL
156 PORTER STREET UNIT 344
BOSTON MA 02128

64 LUBEC LLC
BROOK PROPERTY MANAGEMENT
BROOKLINE MA 02446

WILLIAMS DAVID
156 PORTER ST # 332
EAST BOSTON MA 02128

MARR DONALD F TS
99 GOVE ST #10
EAST BOSTON MA 02128

DLUGOS RACHEL A
6770 HAWAII KAI DR #1407
HONOLULU HI 96825

LYTER RENEE
156 PORTER ST # 156
EAST BOSTON MA 02128

MURRAY RAYMOND P
24 SMITH ST
CHAPPAQUA NY 10514

ADKINS DON ALEXANDER
156 PORTER ST # 230
EAST BOSTON MA 02128

CRAMER BRUCE J
99 GOVE ST #8
EAST BOSTON MA 02128

LEE MANDY
156 PORTER ST # 241
EAST BOSTON MA 02128

CARABOOLAD GEOFFREY TS
55 HENSHAW ST
BRIGHTON MA 02135

FRESH TURF LLC
7 CERINA RD
JAMAICA PLAIN MA 02130

AGBEY VICTORIA L
156 PORTER ST #113
EAST BOSTON MA 02128

MASS DEPT OF TRANSPORTATION
PRESCOTT ST
EAST BOSTON MA 02128

FITZGERALD JO ANN
156 PORTER ST
EAST BOSTON MA 02128

64 FRANKFORT STREET LLC
264 SALEM ST
MEDFORD MA 02155

HADRIAN LLC MASS LLC
411 BUNKER HILL ST #2
CHARLESTOWN MA 02129

HOPKINS AARON
156 PORTER ST, Unit 223
EAST BOSTON MA 02128

WHITE JENNIFER
80 FRANKFORT ST
EAST BOSTON MA 02128

SAVOIE JOHN AARON
156 PORTER ST #250
EAST BOSTON MA 02128

NEMERGUT FREDERICK J TS
156 PORTER ST #221
EAST BOSTON MA 02128

PHILLIPS PAUL B
156 PORTER ST # 111
EAST BOSTON MA 02128

PREVITE PETER M
120 HOLMES STREET #217E
QUINCY MA 02171

STEFANINI MELISSA
156 PORTER ST # 153
EAST BOSTON MA 02128

SARMIENTO ALBERTO E
156 PORTER ST #402
EAST BOSTON MA 02128

TOPONARSKI MARTINA
156 PORTER ST # 326
EAST BOSTON MA 02128

LIU CHUN HUA
72 LUBEC ST #6
E BOSTON MA 02128

DILLON DEREK A
156 PORTER ST UNIT 143
EAST BOSTON MA 02128

STAUFFER ELYSIA B
156 PORTER ST # 349
EAST BOSTON MA 02128

LONDONO MIGUEL F
156 PORTER ST #408
EAST BOSTON MA 02128

MILLER ALEXIS
156 PORTER ST # 232
EAST BOSTON MA 02128

THOMAS J VACIRCA MARITAL TRUST
330 COREY ST
WEST ROXBURY MA 02132

SMITH HEIDI
156 PORTER ST, Unit 120
EAST BOSTON MA 02128

ZULPS ALBERT
156 PORTER ST #352
EAST BOSTON MA 02128

TANGBAN NEJI
156 PORTER ST # 424
EAST BOSTON MA 02128

LAWRENCE J HICKEY REVOCABLE
TRUST
156 PORTER ST # 133
EAST BOSTON MA 02128

DEEDY JANE M
44 HIGHLAND AV
WINTHROP MA 02152

PUOPOLO STEVEN TRST
68 FRANKFORT
EAST BOSTON MA 02128

HAIMINIS JONATHAN YONI
72 LUBEC ST #1
EAST BOSTON MA 02128

AGNEW JOHN
156 PORTER ST # 421
EAST BOSTON MA 02128

KELLY ANN MYERS
156 PORTER ST, Unit 256
EAST BOSTON MA 02128

GRILLO JULIO
32 ELLEN RD
STONEHAM MA 02180

WOO ERNEST
156 PORTER ST #126
EAST BOSTON MA 02128

TARANTINO JESSE A
156 PORTER ST # 204
EAST BOSTON MA 02128

TOFANI VINCENT A
156 PORTER ST #405
EAST BOSTON MA 02128

HERBERT JAMES M
156 PORTER ST #428
EAST BOSTON MA 02128

MUHLANGER ERICH JR
1 CARL RD
ARLINGTON MA 02474

DADON DANIEL
156 PORTER ST #336
EAST BOSTON MA 02128

ONE 35 BREMEN STREET LLC
1222 BENNINGTON ST
EAST BOSTON MA 02128

CITY OF BOSTON
ORLEANS
EAST BOSTON MA 02128

FLEMING EDWARD
156 PORTER ST., # 311
EAST BOSTON MA 02128

SARNO ROBERT
156 PORTER ST UNIT #429
EAST BOSTON MA 02128

CAMPBELL TARIKH
156 PORTER ST, Unit 202
EAST BOSTON MA 02128

SHEEHAN MARIE ANTOINETTE
156 PORTER ST #104
EAST BOSTON MA 02128

LANDERS STEWART
156 PORTER ST #425
EAST BOSTON MA 02128

PREVITE PETER M
120 HOLMES ST #217E
QUINCY MA 02171

SZUSTKA CORNELIA J
156 PORTER ST, Unit 407
EAST BOSTON MA 02128

RIVERA RICHARD
156 PORTER ST # 231
EAST BOSTON MA 02128

SHANNON LISA
156 PORTER ST #438
EAST BOSTON MA 02128

VILLANI STEPHEN
72 LUBEC ST, #2
EAST BOSTON MA 02128

RILEY BRIDGET
156 PORTER ST # 136
EAST BOSTON MA 02128

BLYTHE ERIC
99 GOVE ST #11
E BOSTON MA 02128

PIAZZA GIOVANNA
4 MICHAEL DR
DANVERS MA 01923

SCHNEIDERMAN WILLIAM J
156 PORTER ST # 335
EAST BOSTON MA 02128

LLEWELLYN TIMOTHY J
156 PORTER ST #330
EAST BOSTON MA 02128

ABBATE MICHAEL LUCIANO
156 PORTER ST # 134
EAST BOSTON MA 02128

FRANKFORT GOVE LLC
220 BOYLSTON ST #1214
BOSTON MA 02116

EAST BOSTON NEIGHBORHOOD
10 GROVE ST
E BOSTON MA 02128

CHENG JENNY
156 PORTER ST #353
EAST BOSTON MA 02128

GURNEY DANIEL
7 GUILFORD ST
WORCESTER MA 01601

LEE SHUI MAN
72 LUBEC ST, Unit 8
EAST BOSTON MA 02128

LEE RAYMOND HOK-MAN
72 LUBEC ST, Unit 20
EAST BOSTON MA 02128

CARMODY MATTHEW
156 PORTER ST #342
EAST BOSTON MA 02128

MCENERNEY JOHN M
156 PORTER ST #448
EAST BOSTON MA 02128

SMITH RYAN
156 PORTER ST # 146
EAST BOSTON MA 02128

PICATOSTE FERNANDO D
156 PORTER ST # 212
EAST BOSTON MA 02128

PARK HEE MONG
156 PORTER ST #413
E BOSTON MA 02128

CALHOUN KENNETH
249 A ST #63
SOUTH BOSTON MA 02127

LYSIAK MARY A
99 GOVE ST #1
EAST BOSTON MA 02128

GRILLO JULIO
69 FRANKFORT ST
EAST BOSTON MA 02128

VENTER JACOB
156 PORTER ST, Unit 434
EAST BOSTON MA 02128

PELLETIER ERIK C
156 PORTER ST # 245
EAST BOSTON MA 02128

FALZONE SALVATORE
62 FRANKFORT ST
EAST BOSTON MA 02128

CURRY LORRAINE
72 LUBEC ST, #23
EAST BOSTON MA 02128

KU SANG
156 PORTER ST #106
EAST BOSTON MA 02128

HUDSON 62 REALTY LLC
83 HARTWELL AVE
LEXINGTON MA 02421

GOLDIE FAMILY 2003 TRUST
25 KNOLLWOOD COURT
BURLINGTON MA 01803

MAVERICK SQUARE MANAGEMENT
LLC
8 ALTON PLACE
BROOKLINE MA 02446

MARIANO ARCANGELO
156 PORTER ST #437
EAST BOSTON MA 02128

MCORLEANS JC FAMILY LP
23 BAYSWATER ST
EAST BOSTON MA 02128

KOFFEL BENJAMIN
156 PORTER ST UNIT 206
BOSTON MA 02128

TRIPLET HOLDINGS LLC
1810 BEACON ST
BROOKLINE MA 02445

MANTIA DEANNE
23 PLEASANT AV
SAUGUS MA 01906

CASSELLA CRISTIAN
156 PORTER ST #117
EAST BOSTON MA 02128

OLIVER SHANNON E
156 PORTER ST # 226
EAST BOSTON MA 02128

MUNERA ALONSO
156 PORTER ST #357
EAST BOSTON MA 02128

RAYMOND STEPHEN
156 PORTER ST #242
EAST BOSTON MA 02128

BUZELLI PATRICIA G
156 PORTER ST, Unit 147
EAST BOSTON MA 02128

SIBERT STEPHEN
156 PORTER ST #129
EAST BOSTON MA 02128

SIXTY 7 FRANKFORT STREET
67 FRANKFORT
EAST BOSTON MA 02128

LING TSIN YUEN JEANNE
4079 NC 903 SOUTH
WINTERVILLE NC 28590

SLATTERY KEVIN
35 MORELAND ST
SOMERVILLE MA 02145

DICENSO MARK
156 PORTER ST #327
BOSTON MA 02128

SMITH MATTHEW B
529 COLUMBUS AVENUE APT 6
BOSTON MA 02118

LAWRENCE BARBARA L
156 PORTER ST #347
EAST BOSTON MA 02128

DIPIETRO MADDALEN M
72 LUBEC ST #12
EAST BOSTON MA 02128

ALI OMAR H
156 PORTER ST # 409
EAST BOSTON MA 02128

KURKOWSKI MATTHEW
156 PORTER ST # 234
EAST BOSTON MA 02128

LE HIEU TRUNG
156 PORTER ST #309
EAST BOSTON MA 02128

MONTEITH IAN M
156 PORTER ST #144
EAST BOSTON MA 02128

DONAHUE MARIE L
156 PORTER ST, Unit 406
EAST BOSTON MA 02128

CHERENFANT ELI SOLOMON
156 PORTER ST #310
EAST BOSTON MA 02128

BOSTON CUMMUNITY PROPERTIES LLC
231 EAST MAIN ST
WESTBORO MA 01581

NANCY J MILLS REVOCABLE TRUST
PO BOX 53
E BOSTON MA 02128

CONLON KENDRA
72 LUBEC ST #9
EAST BOSTON MA 02128

CARAMBELAS CASLYNN
156 PORTER ST # 132
EAST BOSTON MA 02128

CUNNINGHAM JOSEPH W
156 PORTER ST # 427
EAST BOSTON MA 02128

STONKUS CHRISTINA
72 LUBEC ST #22
EAST BOSTON MA 02128

DILIBERO NICOLA R JR TS
30A WINDING OAKS WAY
BOXFORD MA 01921

DUGAN ERIN A
156 PORTER ST #420
EAST BOSTON MA 02128

FURRH JARRETT
2600 W 7TH ST #1801
FORT WORTH TX 76107

EVERETT ANDREW
156 PORTER ST #313
EAST BOSTON MA 02128

DANIELE FRANCESCO F
99 GOVE ST #5
EAST BOSTON MA 02128

LEETE ELAINE T TS
156 PORTER ST # 118
EAST BOSTON MA 02128

AROSTEGUI-HAM INGRID VIVIANA
81 HAGGETT'S POND RD
ANDOVER MA 01810

YANG GUANG
156 PORTER ST # 350
EAST BOSTON MA 02128

QUINN WILLIAM F III
56 Frankfort ST
EAST BOSTON MA 02128

WHITE JENNIFER
80 FRANKFORT ST
EAST BOSTON MA 02128

TOPOLINO REALTY TRUST
165 TREMONT ST #602
BOSTON MA 02111

MCPHEE MICHELE R
156 PORTER ST #237
EAST BOSTON MA 02128

MARTIN SUSAN R
156 PORTER ST # 115
EAST BOSTON MA 02128

E BOSTON NEIGHBORHOOD HEALTH
10 GOVE ST
EAST BOSTON MA 02128

FREYTSIS ILYA
16 MILLET RD
SWAMPSCOTT MA 01907

SALK MICHAEL
67 FRANKFORT ST #102
EAST BOSTON MA 02128

BRIGGS KRISTEN
8 STONEBRIDGE RD
GROVELAND MA 01834

MCWADE PATRICIA ANN
64 Frankfort ST, Unit 6
EAST BOSTON MA 02128

NICRON LLC
PO BOX 53
EAST BOSTON MA 02128

ARAKELIAN MARK
72 LUBEC STREET #13
EAST BOSTON MA 02128

TALKOV PAUL
156 PORTER ST # 213
EAST BOSTON MA 02128

HARRIS KEVIN C
156 PORTER ST #243
EAST BOSTON MA 02128

GENTILELLA DACIA
156 PORTER ST #401
EAST BOSTON MA 02128

LU SHAWN
99 GOVE ST #12
EAST BOSTON MA 02128

AHMED SOHA
156 PORTER ST # 112
EAST BOSTON MA 02128

OCONNOR BRIAN J TS
72 BRIDGE ST
CARTHAGE NY 13619

CARABOOLAD GEOFFREY TS
55 HENSHAW ST
BRIGHTON MA 02135

JANCEWICZ INGA VABA
156 PORTER ST #233
EAST BOSTON MA 02128

JENNESS COLE ROBERTS
156 PORTER ST, Unit 142
EAST BOSTON MA 02128

COMM OF MASS
150 PORTER
EAST BOSTON MA 02128

GILPIN RICHARD P
156 PORTER ST # 321
EAST BOSTON MA 02128

WHITNEY ROBIN
156 PORTER ST, Unit 240
EAST BOSTON MA 02128

SYED ZEBA A
156 PORTER ST # 228
EAST BOSTON MA 02128

MARQUEZ CECILIA I
156 PORTER ST #152
EAST BOSTON MA 02128

FRANKFORT GOVE LLC
220 BOYLSTON ST #1214
BOSTON MA 02116

A & D MUNERA REVOCABLE TRUST
156 PORTER ST, Unit 341
EAST BOSTON MA 02128

GARZON JUAN CARLOS
156 PORTER ST # 217
EAST BOSTON MA 02128

THE PORTER 156 CONDOMINIUM
TRUST
156 PORTER ST
EAST BOSTON MA 02128

BANKEY ERIK S
99 GOVE ST
EAST BOSTON MA 02128

LEE RAYMOND HOK MAN
72 LUBEC ST #20
EAST BOSTON MA 02128

FUNG CHEUK HANG
72 LUBEC ST #15
EAST BOSTON MA 02128

HORENSTEIN HENRY
156 PORTER ST #444
E BOSTON MA 02128

FUNG GORDON C
156 PORTER ST UNIT 422
EAST BOSTON MA 02128

CARCO ERIC
156 PORTER ST #138
EAST BOSTON MA 02128

SHOON HEATHER
156 PORTER ST, Unit 236
EAST BOSTON MA 02128

BORTHWICK JESSE
156 PORTER ST # 109
EAST BOSTON MA 02128

DORVEL ROBERT A
156 PORTER ST #404
EAST BOSTON MA 02128

SHAH KINNELL SANDEEP
156 PORTER ST # 307
EAST BOSTON MA 02128

EDGECOMB MISTY
9789 TWILIGHT MOON AVENUE
LAS VEGAS NV 89148

NICRON LLC
PO BOX 53
EAST BOSTON MA 02128

SAMPSON JILL
156 PORTER ST # 209
EAST BOSTON MA 02128

DADDONA NICHOLAS J
156 PORTER ST # 225
EAST BOSTON MA 02128

MT CARMEL CONDO TR
83 PINE
PEABODY MA 01960

CLARKE RICHARD
156 PORTER ST # 148
EAST BOSTON MA 02128

CASS KRYSTA
156 PORTER ST #322
EAST BOSTON MA 02128

HUBINES JOSIE EVANGELISTA
156 PORTER ST # 107
EAST BOSTON MA 02128

BRUCE ALEX
156 PORTER ST, Unit 440
EAST BOSTON MA 02128

BARADARANSHORAKA MOHAMMAD
156 PORTER ST, Unit 403
EAST BOSTON MA 02128

NULTY THOMAS M
99 GROVE ST #14
EAST BOSTON MA 02128

CHAN CHRISTOPHER
156 PORTER ST # 140
EAST BOSTON MA 02128

KOTHANDARAMAN MURALI
7 SHERBURNE ROAD
LEXINGTON MA 02421

TANG YONG QIANG
72 LUBEC ST #19
EAST BOSTON MA 02128

MYSKO TANYA C
156 PORTER ST # 303
EAST BOSTON MA 02128

KEITH LAURA
156 PORTER ST # 208
EAST BOSTON MA 02128

MARCHIONE CONCETTA
76 FRANKFORT ST
EAST BOSTON MA 02128

SCHAEFER TODD
156 PORTER ST # 343
EAST BOSTON MA 02128

GARIBALDI JORGE
156 PORTER ST UNIT 235
BOSTON MA 02128

FARZADFARD FAHIM
156 PORTER ST, Unit 301
EAST BOSTON MA 02128

PREVITE PETER M
120 HOLMES STREET #217E
QUINCY MA 02171

HUDSON 62 REALTY LLC
83 HARTWELL AVE
LEXINGTON MA 02421

**JOHNS CHRISTOPHER A
156 PORTER ST #339
EAST BOSTON MA 02128**

**BIGELOW BRYAN
156 PORTER ST # 446
EAST BOSTON MA 02128**

**MCDONALD CHELSI M
64 Frankfort ST, Unit 1
EAST BOSTON MA 02128**

**COSTELLO DAVID
156 PORTER ST # 239
EAST BOSTON MA 02128**

**FERRERA SALVATORE A JR TS
60 FRANKFORT ST
EAST BOSTON MA 02128**

**CHAPMAN DAVID J
38 JUNIOR STREET
NEW BEDFORD MA 02740**

**ABATE PATRICK JAMES
156 PORTER ST, Unit 116
EAST BOSTON MA 02128**

**COBURN KYLE E
156 PORTER ST, Unit 442
EAST BOSTON MA 02128**

**CHARMOY STANLEY TS
1 ROBIN HILL RD
DANVERS MA 01923**

**FAZIO MICHAEL
156 PORTER ST # 252
EAST BOSTON MA 02128**

**KELLY CHRISTOPHER
156 PORTER ST, Unit 119
EAST BOSTON MA 02128**

**JENKINS SCOTT W
156 PORTER ST
EAST BOSTON MA 02128**

**DANIEL WEBSTER CONDO TR
72 LUBEC ST
EAST BOSTON MA 02128**

**DEBENEDICTIS JOHN C
72 LUBEC ST #18
EAST BOSTON MA 02128**

**OHEARN ERIN K
156 PORTER ST #248
EAST BOSTON MA 02128**

**SICILIANO GREGORY A
4 THE GREAT ROAD
WOBURN MA 01801**

**MCVAY MICHAEL
156 PORTER ST # 105
EAST BOSTON MA 02128**

**FETTIPLACE MICHAEL ROBERT
156 PORTER ST # 305
EAST BOSTON MA 02128**

**156 PORTER UNIT 157 REALTY TRUST
C/O WILLIAM LEVY
WILTON MANORS MA 33334**

**DROWNE ANDREW D
156 PORTER ST #216
EAST BOSTON MA 02128**



**NOTIFICATION TO ABUTTERS
BOSTON CONSERVATION COMMISSION**

In accordance with the Massachusetts Wetlands Protection Act, Massachusetts General Laws Chapter 131, Section 40, and the Boston Wetlands Ordinance, you are hereby notified as an abutter to a project filed with the Boston Conservation Commission.

A. **A. Patel** has filed a Notice of Intent with the Boston Conservation Commission seeking permission to alter an Area Subject to Protection under the Wetlands Protection Act (General Laws Chapter 131, section 40) and Boston Wetlands Ordinance.

B. The address of the lot where the activity is proposed is **155 Porter Street, East Boston.**

C. The project involves **renovation of a five-story building into a hotel, with two parking lots, adjacent to Orleans and Frankfort Streets.**

D. Copies of the Notice of Intent may be obtained by contacting the Boston Conservation Commission at CC@boston.gov.

E. Copies of the Notice of Intent may be obtained from: **Ivas Environmental, at 781.659.1690 or spivas@comcast.net between the hours of 9 AM and 5 PM Monday – Friday.**

F. In accordance with the Commonwealth of Massachusetts Executive Order Suspending Certain Provisions of the Open Meeting Law, the public hearing will take place **virtually** at <https://zoom.us/j/6864582044>. If you are unable to access the internet, you can call 1-929-205-6099, enter Meeting ID 686 458 2044 # and use # as your participant ID.

G. Information regarding the date and time of the public hearing may be obtained from the **Boston Conservation Commission** by emailing CC@boston.gov or calling **(617) 635-3850** between the hours of **9 AM to 5 PM, Monday through Friday.**

NOTE: Notice of the public hearing, including its date, time, and place, will be published at least five (5) days in advance in the **Boston Herald.**

NOTE: Notice of the public hearing, including its date, time, and place, will be posted on www.boston.gov/public-notices and in Boston City Hall not less than forty-eight (48) hours in advance.

NOTE: If you would like to provide comments, you may attend the public hearing or send written comments to CC@boston.gov or Boston City Hall, Environment Department, Room 709, 1 City Hall Square, Boston, MA 02201

NOTE: You also may contact the Boston Conservation Commission or the Department of Environmental Protection Northeast Regional Office for more information about this application or the Wetlands Protection Act. To contact DEP, call: the Northeast Region: (978) 694-3200.



**NOTIFICACIÓN PARA PROPIETARIOS Y/O VECINOS COLINDANTES
COMISIÓN DE CONSERVACIÓN DE BOSTON**

De conformidad con la Ley de protección de los humedales de Massachusetts, el Capítulo 131, Sección 40 de las Leyes Generales de Massachusetts y la Ordenanza sobre los humedales de Boston, por la presente queda usted notificado como propietario o vecino colindante de un proyecto presentado ante la Comisión de Conservación de Boston.

A. **A. Patel** ha presentado una solicitud a la Comisión de Conservación de Boston pidiendo permiso para modificar una zona sujeta a protección en virtud de la Ley de protección de los humedales (Leyes generales, capítulo 131, sección 40) y la Ordenanza sobre los humedales de Boston.

B. La dirección del lote donde se propone la actividad es **155 Porter Street, East Boston**.

C. El proyecto consiste en **Renovation of building site into a hotel and two parking lots**.

D. Se pueden obtener copias del Aviso de Intención comunicándose con la Comisión de Conservación de Boston en CC@boston.gov.

E. Las copias de la notificación de intención pueden obtenerse en **Ivas Environmental, 781.659.1690 or spivas@comcast.net entre las 900AM and 500 PM Monday Through Friday**.

F. De acuerdo con el Decreto Ejecutivo de la Mancomunidad de Massachusetts que suspende ciertas disposiciones de la Ley de reuniones abiertas, la audiencia pública se llevará a cabo virtualmente en <https://zoom.us/j/6864582044>. Si no puede acceder a Internet, puede llamar al 1-929-205-6099, ingresar ID de reunión 686 458 2044 # y usar # como su ID de participante.

G. La información relativa a la fecha y hora de la audiencia pública puede solicitarse a la **Comisión de Conservación de Boston** por correo electrónico a CC@boston.gov o llamando al **(617) 635-4416** entre las **9 AM y las 5 PM, de lunes a viernes**.

NOTA: La notificación de la audiencia pública, incluida su fecha, hora y lugar, se publicará en el **Boston Herald** con al menos cinco (5) días de antelación.

NOTA: La notificación de la audiencia pública, incluida su fecha, hora y lugar, se publicará en www.boston.gov/public-notice y en el Ayuntamiento de Boston con no menos de cuarenta y ocho (48) horas de antelación. Si desea formular comentarios, puede asistir a la audiencia pública o enviarlos por escrito a CC@boston.gov o al Ayuntamiento de Boston, Departamento de Medio Ambiente, Sala 709, 1 City Hall Square, Boston, MA 02201.

NOTA: También puede comunicarse con la Comisión de Conservación de Boston o con la Oficina Regional del Noreste del Departamento de Protección Ambiental para obtener más información sobre esta solicitud o la Ley de Protección de Humedales. Para comunicarse con el DEP, llame a la Región Noreste: (978) 694-3200.



City of Boston
Environment



City of Boston
Mayor Martin J. Walsh

NOTA: si tiene previsto asistir a la audiencia pública y necesita servicios de interpretación, sírvase informar al personal en CC@boston.gov antes de las 12 PM del día anterior a la audiencia.



BABEL NOTICE

English:

IMPORTANT! This document or application contains **important information** about your rights, responsibilities and/or benefits. It is crucial that you understand the information in this document and/or application, and we will provide the information in your preferred language at no cost to you. If you need them, please contact us at cc@boston.gov or 617-635-3850.

Spanish:

¡IMPORTANTE! Este documento o solicitud contiene **información importante** sobre sus derechos, responsabilidades y/o beneficios. Es fundamental que usted entienda la información contenida en este documento y/o solicitud, y le proporcionaremos la información en su idioma preferido sin costo alguno para usted. Si los necesita, póngase en contacto con nosotros en el correo electrónico cc@boston.gov o llamando al 617-635-3850.

Haitian Creole:

AVI ENPÒTAN! Dokiman oubyen aplikasyon sa genyen **enfòmasyon ki enpòtan** konsènan dwa, responsablite, ak/oswa benefis ou yo. Li enpòtan ke ou konprann enfòmasyon ki nan dokiman ak/oubyen aplikasyon sa, e n ap bay enfòmasyon an nan lang ou prefere a, san ou pa peye anyen. Si w bezwen yo, tanpri kontakte nou nan cc@boston.gov oswa 617-635-3850.

Traditional Chinese:

非常重要！這份文件或是申請表格包含關於您的權利，責任，和／或福利的重要信息。請您務必完全理解這份文件或申請表格的全部信息，這對我們來說十分重要。我們會免費給您提供翻譯服務。如果您有需要請聯系我們的郵箱 cc@boston.gov 電話# 617-635-3850..

Vietnamese:

QUAN TRỌNG! Tài liệu hoặc đơn yêu cầu này chứa **thông tin quan trọng** về các quyền, trách nhiệm và/hoặc lợi ích của bạn. Việc bạn hiểu rõ thông tin trong tài liệu và/hoặc đơn yêu cầu này rất quan trọng, và chúng tôi sẽ cung cấp thông tin bằng ngôn ngữ bạn muốn mà không tính phí. Nếu quý vị cần những dịch vụ này, vui lòng liên lạc với chúng tôi theo địa chỉ cc@boston.gov hoặc số điện thoại 617-635-3850.

Simplified Chinese:

非常重要！这份文件或是申请表格包含关于您的权利，责任，和／或福利的重要信息。请您务必完全理解这份文件或申请表格的全部信息，这对我们来说十分重要。我们会免费给您提供翻译服务。如果您有需要请联联系我们的邮箱 cc@boston.gov 电话# 617-635-3850.

Cape Verdean Creole:

INPURTANTI! Es dukumentu ó aplikason ten **informason inpur tanti** sobri bu direitus, rasponsabilidadi i/ó benefisius. Ê krusial ki bu intendi informason na es dukumentu i/ó aplikason ó nu ta da informason na língua di bu preferênsia sen ninhun kustu pa bó. Si bu prisiza del, kontata-nu na cc@boston.gov ó 617-635-3850.

Arabic:

مهم! يحتوي هذا المستند أو التطبيق على معلومات مهمة حول حقوقك ومسؤولياتك أو فوائده. من الأهمية أن تفهم المعلومات الواردة في هذا المستند أو التطبيق. سوف نقدم المعلومات بلغتك المفضلة دون أي تكلفة عليك. إذا كنت في حاجة إليها، يرجى الاتصال بنا على cc@boston.gov أو 617-635-3850.

Russian:

ВАЖНО! В этом документе или заявлении содержится **важная информация** о ваших правах, обязанностях и/или льготах. Для нас очень важно, чтобы вы понимали приведенную в этом документе и/или заявлении информацию, и мы готовы бесплатно предоставить вам информацию на предпочитаемом вами языке. Если Вам они нужны, просьба связаться с нами по адресу электронной почты cc@boston.gov, либо по телефону 617-635-3850.

Portuguese:

IMPORTANTE! Este documento ou aplicativo contém **Informações importantes** sobre os seus direitos, responsabilidades e/ou benefícios. É importante que você compreenda as informações contidas neste documento e/ou aplicativo, e nós iremos fornecer as informações em seu idioma de preferência sem nenhum custo para você. Se precisar deles, fale conosco: cc@boston.gov ou 617-635-3850.

French:

IMPORTANT ! Ce document ou cette demande contient des **informations importantes** concernant vos droits, responsabilités et/ou avantages. Il est essentiel que vous compreniez les informations contenues dans ce document et/ou cette demande, que nous pouvons vous communiquer gratuitement dans la langue de votre choix. Si vous en avez besoin, veuillez nous contacter à cc@boston.gov ou au 617-635-3850.



STORMWATER MANAGEMENT STANDARDS NARRATIVE

PREPARED JUNE 15,2021

APPLICANT:

HUDSON 62 REALTY, LLC

83 HARTWELL AVE, LEXINGTON, MA

PROJECT:

PROPOSED REDEVELOPMENT

155 PORTER STREET, EAST BOSTON, MA

PREPARED BY:

PVI SITE DESIGN, LLC

18 GLENDALE ROAD, NORWOOD, MA 02062

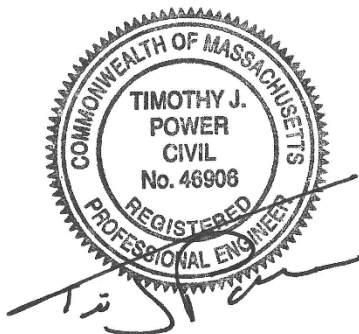

TABLE OF CONTENTS:

- Stormwater Management Checklist
- Stormwater Management Standards Narrative
- Stormwater Operations & Maintenance Plan
- Supporting Calculations
 - Stage Storage Table
 - TSS Removal Calculations
- NRCS Soils Maps



Checklist for Stormwater Report

A. Introduction

Important: When filling out forms on the computer, use only the tab key to move your cursor - do not use the return key.



A Stormwater Report must be submitted with the Notice of Intent permit application to document compliance with the Stormwater Management Standards. The following checklist is NOT a substitute for the Stormwater Report (which should provide more substantive and detailed information) but is offered here as a tool to help the applicant organize their Stormwater Management documentation for their Report and for the reviewer to assess this information in a consistent format. As noted in the Checklist, the Stormwater Report must contain the engineering computations and supporting information set forth in Volume 3 of the [Massachusetts Stormwater Handbook](#). The Stormwater Report must be prepared and certified by a Registered Professional Engineer (RPE) licensed in the Commonwealth.

The Stormwater Report must include:

- The Stormwater Checklist completed and stamped by a Registered Professional Engineer (see page 2) that certifies that the Stormwater Report contains all required submittals.¹ This Checklist is to be used as the cover for the completed Stormwater Report.
- Applicant/Project Name
- Project Address
- Name of Firm and Registered Professional Engineer that prepared the Report
- Long-Term Pollution Prevention Plan required by Standards 4-6
- Construction Period Pollution Prevention and Erosion and Sedimentation Control Plan required by Standard 8²
- Operation and Maintenance Plan required by Standard 9

In addition to all plans and supporting information, the Stormwater Report must include a brief narrative describing stormwater management practices, including environmentally sensitive site design and LID techniques, along with a diagram depicting runoff through the proposed BMP treatment train. Plans are required to show existing and proposed conditions, identify all wetland resource areas, NRCS soil types, critical areas, Land Uses with Higher Potential Pollutant Loads (LUHPPL), and any areas on the site where infiltration rate is greater than 2.4 inches per hour. The Plans shall identify the drainage areas for both existing and proposed conditions at a scale that enables verification of supporting calculations.

As noted in the Checklist, the Stormwater Management Report shall document compliance with each of the Stormwater Management Standards as provided in the Massachusetts Stormwater Handbook. The soils evaluation and calculations shall be done using the methodologies set forth in Volume 3 of the Massachusetts Stormwater Handbook.

To ensure that the Stormwater Report is complete, applicants are required to fill in the Stormwater Report Checklist by checking the box to indicate that the specified information has been included in the Stormwater Report. If any of the information specified in the checklist has not been submitted, the applicant must provide an explanation. The completed Stormwater Report Checklist and Certification must be submitted with the Stormwater Report.

¹ The Stormwater Report may also include the Illicit Discharge Compliance Statement required by Standard 10. If not included in the Stormwater Report, the Illicit Discharge Compliance Statement must be submitted prior to the discharge of stormwater runoff to the post-construction best management practices.

² For some complex projects, it may not be possible to include the Construction Period Erosion and Sedimentation Control Plan in the Stormwater Report. In that event, the issuing authority has the discretion to issue an Order of Conditions that approves the project and includes a condition requiring the proponent to submit the Construction Period Erosion and Sedimentation Control Plan before commencing any land disturbance activity on the site.



Checklist for Stormwater Report

B. Stormwater Checklist and Certification

The following checklist is intended to serve as a guide for applicants as to the elements that ordinarily need to be addressed in a complete Stormwater Report. The checklist is also intended to provide conservation commissions and other reviewing authorities with a summary of the components necessary for a comprehensive Stormwater Report that addresses the ten Stormwater Standards.

Note: Because stormwater requirements vary from project to project, it is possible that a complete Stormwater Report may not include information on some of the subjects specified in the Checklist. If it is determined that a specific item does not apply to the project under review, please note that the item is not applicable (N.A.) and provide the reasons for that determination.

A complete checklist must include the Certification set forth below signed by the Registered Professional Engineer who prepared the Stormwater Report.

Registered Professional Engineer's Certification

I have reviewed the Stormwater Report, including the soil evaluation, computations, Long-term Pollution Prevention Plan, the Construction Period Erosion and Sedimentation Control Plan (if included), the Long-term Post-Construction Operation and Maintenance Plan, the Illicit Discharge Compliance Statement (if included) and the plans showing the stormwater management system, and have determined that they have been prepared in accordance with the requirements of the Stormwater Management Standards as further elaborated by the Massachusetts Stormwater Handbook. I have also determined that the information presented in the Stormwater Checklist is accurate and that the information presented in the Stormwater Report accurately reflects conditions at the site as of the date of this permit application.

Registered Professional Engineer Block and Signature

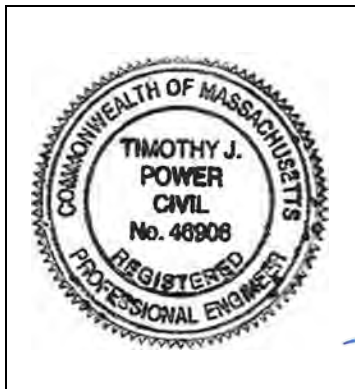

Signature and Date

6-15-2021

Checklist

Project Type: Is the application for new development, redevelopment, or a mix of new and redevelopment?

- New development
- Redevelopment
- Mix of New Development and Redevelopment



Checklist for Stormwater Report

Checklist (continued)

LID Measures: Stormwater Standards require LID measures to be considered. Document what environmentally sensitive design and LID Techniques were considered during the planning and design of the project:

- No disturbance to any Wetland Resource Areas
- Site Design Practices (e.g. clustered development, reduced frontage setbacks)
- Reduced Impervious Area (Redevelopment Only)
- Minimizing disturbance to existing trees and shrubs
- LID Site Design Credit Requested:
 - Credit 1
 - Credit 2
 - Credit 3
- Use of "country drainage" versus curb and gutter conveyance and pipe
- Bioretention Cells (includes Rain Gardens)
- Constructed Stormwater Wetlands (includes Gravel Wetlands designs)
- Treebox Filter
- Water Quality Swale
- Grass Channel
- Green Roof
- Other (describe): _____

Standard 1: No New Untreated Discharges

- No new untreated discharges
- Outlets have been designed so there is no erosion or scour to wetlands and waters of the Commonwealth
- Supporting calculations specified in Volume 3 of the Massachusetts Stormwater Handbook included.



Checklist for Stormwater Report

Checklist (continued)

Standard 2: Peak Rate Attenuation

- Standard 2 waiver requested because the project is located in land subject to coastal storm flowage and stormwater discharge is to a wetland subject to coastal flooding.
- Evaluation provided to determine whether off-site flooding increases during the 100-year 24-hour storm.
- Calculations provided to show that post-development peak discharge rates do not exceed pre-development rates for the 2-year and 10-year 24-hour storms. If evaluation shows that off-site flooding increases during the 100-year 24-hour storm, calculations are also provided to show that post-development peak discharge rates do not exceed pre-development rates for the 100-year 24-hour storm.

Standard 3: Recharge

- Soil Analysis provided.
- Required Recharge Volume calculation provided.
- Required Recharge volume reduced through use of the LID site Design Credits.
- Sizing the infiltration, BMPs is based on the following method: Check the method used.
 - Static
 - Simple Dynamic
 - Dynamic Field¹
- Runoff from all impervious areas at the site discharging to the infiltration BMP.
- Runoff from all impervious areas at the site is *not* discharging to the infiltration BMP and calculations are provided showing that the drainage area contributing runoff to the infiltration BMPs is sufficient to generate the required recharge volume.
- Recharge BMPs have been sized to infiltrate the Required Recharge Volume.
- Recharge BMPs have been sized to infiltrate the Required Recharge Volume *only* to the maximum extent practicable for the following reason:
 - Site is comprised solely of C and D soils and/or bedrock at the land surface
 - M.G.L. c. 21E sites pursuant to 310 CMR 40.0000
 - Solid Waste Landfill pursuant to 310 CMR 19.000
 - Project is otherwise subject to Stormwater Management Standards only to the maximum extent practicable.
- Calculations showing that the infiltration BMPs will drain in 72 hours are provided.
- Property includes a M.G.L. c. 21E site or a solid waste landfill and a mounding analysis is included.

¹ 80% TSS removal is required prior to discharge to infiltration BMP if Dynamic Field method is used.



Checklist for Stormwater Report

Checklist (continued)

Standard 3: Recharge (continued)

- The infiltration BMP is used to attenuate peak flows during storms greater than or equal to the 10-year 24-hour storm and separation to seasonal high groundwater is less than 4 feet and a mounding analysis is provided.
- Documentation is provided showing that infiltration BMPs do not adversely impact nearby wetland resource areas.

Standard 4: Water Quality

The Long-Term Pollution Prevention Plan typically includes the following:

- Good housekeeping practices;
 - Provisions for storing materials and waste products inside or under cover;
 - Vehicle washing controls;
 - Requirements for routine inspections and maintenance of stormwater BMPs;
 - Spill prevention and response plans;
 - Provisions for maintenance of lawns, gardens, and other landscaped areas;
 - Requirements for storage and use of fertilizers, herbicides, and pesticides;
 - Pet waste management provisions;
 - Provisions for operation and management of septic systems;
 - Provisions for solid waste management;
 - Snow disposal and plowing plans relative to Wetland Resource Areas;
 - Winter Road Salt and/or Sand Use and Storage restrictions;
 - Street sweeping schedules;
 - Provisions for prevention of illicit discharges to the stormwater management system;
 - Documentation that Stormwater BMPs are designed to provide for shutdown and containment in the event of a spill or discharges to or near critical areas or from LUHPPL;
 - Training for staff or personnel involved with implementing Long-Term Pollution Prevention Plan;
 - List of Emergency contacts for implementing Long-Term Pollution Prevention Plan.
- A Long-Term Pollution Prevention Plan is attached to Stormwater Report and is included as an attachment to the Wetlands Notice of Intent.
 - Treatment BMPs subject to the 44% TSS removal pretreatment requirement and the one inch rule for calculating the water quality volume are included, and discharge:
 - is within the Zone II or Interim Wellhead Protection Area
 - is near or to other critical areas
 - is within soils with a rapid infiltration rate (greater than 2.4 inches per hour)
 - involves runoff from land uses with higher potential pollutant loads.
 - The Required Water Quality Volume is reduced through use of the LID site Design Credits.
 - Calculations documenting that the treatment train meets the 80% TSS removal requirement and, if applicable, the 44% TSS removal pretreatment requirement, are provided.



Checklist for Stormwater Report

Checklist (continued)

Standard 4: Water Quality (continued)

- The BMP is sized (and calculations provided) based on:
 - The ½" or 1" Water Quality Volume or
 - The equivalent flow rate associated with the Water Quality Volume and documentation is provided showing that the BMP treats the required water quality volume.
- The applicant proposes to use proprietary BMPs, and documentation supporting use of proprietary BMP and proposed TSS removal rate is provided. This documentation may be in the form of the propriety BMP checklist found in Volume 2, Chapter 4 of the Massachusetts Stormwater Handbook and submitting copies of the TARP Report, STEP Report, and/or other third party studies verifying performance of the proprietary BMPs.
- A TMDL exists that indicates a need to reduce pollutants other than TSS and documentation showing that the BMPs selected are consistent with the TMDL is provided.

Standard 5: Land Uses With Higher Potential Pollutant Loads (LUHPPLs)

- The NPDES Multi-Sector General Permit covers the land use and the Stormwater Pollution Prevention Plan (SWPPP) has been included with the Stormwater Report.
- The NPDES Multi-Sector General Permit covers the land use and the SWPPP will be submitted **prior to** the discharge of stormwater to the post-construction stormwater BMPs.
- The NPDES Multi-Sector General Permit does **not** cover the land use.
- LUHPPLs are located at the site and industry specific source control and pollution prevention measures have been proposed to reduce or eliminate the exposure of LUHPPLs to rain, snow, snow melt and runoff, and been included in the long term Pollution Prevention Plan.
- All exposure has been eliminated.
- All exposure has **not** been eliminated and all BMPs selected are on MassDEP LUHPPL list.
- The LUHPPL has the potential to generate runoff with moderate to higher concentrations of oil and grease (e.g. all parking lots with >1000 vehicle trips per day) and the treatment train includes an oil grit separator, a filtering bioretention area, a sand filter or equivalent.

Standard 6: Critical Areas

- The discharge is near or to a critical area and the treatment train includes only BMPs that MassDEP has approved for stormwater discharges to or near that particular class of critical area.
- Critical areas and BMPs are identified in the Stormwater Report.



Checklist for Stormwater Report

Checklist (continued)

Standard 7: Redevelopments and Other Projects Subject to the Standards only to the maximum extent practicable

- The project is subject to the Stormwater Management Standards only to the maximum Extent Practicable as a:
 - Limited Project
 - Small Residential Projects: 5-9 single family houses or 5-9 units in a multi-family development provided there is no discharge that may potentially affect a critical area.
 - Small Residential Projects: 2-4 single family houses or 2-4 units in a multi-family development with a discharge to a critical area
 - Marina and/or boatyard provided the hull painting, service and maintenance areas are protected from exposure to rain, snow, snow melt and runoff
 - Bike Path and/or Foot Path
- Redevelopment Project
- Redevelopment portion of mix of new and redevelopment.
- Certain standards are not fully met (Standard No. 1, 8, 9, and 10 must always be fully met) and an explanation of why these standards are not met is contained in the Stormwater Report.
- The project involves redevelopment and a description of all measures that have been taken to improve existing conditions is provided in the Stormwater Report. The redevelopment checklist found in Volume 2 Chapter 3 of the Massachusetts Stormwater Handbook may be used to document that the proposed stormwater management system (a) complies with Standards 2, 3 and the pretreatment and structural BMP requirements of Standards 4-6 to the maximum extent practicable and (b) improves existing conditions.

Standard 8: Construction Period Pollution Prevention and Erosion and Sedimentation Control

A Construction Period Pollution Prevention and Erosion and Sedimentation Control Plan must include the following information:

- Narrative;
 - Construction Period Operation and Maintenance Plan;
 - Names of Persons or Entity Responsible for Plan Compliance;
 - Construction Period Pollution Prevention Measures;
 - Erosion and Sedimentation Control Plan Drawings;
 - Detail drawings and specifications for erosion control BMPs, including sizing calculations;
 - Vegetation Planning;
 - Site Development Plan;
 - Construction Sequencing Plan;
 - Sequencing of Erosion and Sedimentation Controls;
 - Operation and Maintenance of Erosion and Sedimentation Controls;
 - Inspection Schedule;
 - Maintenance Schedule;
 - Inspection and Maintenance Log Form.
- A Construction Period Pollution Prevention and Erosion and Sedimentation Control Plan containing the information set forth above has been included in the Stormwater Report.



Checklist for Stormwater Report

Checklist (continued)

Standard 8: Construction Period Pollution Prevention and Erosion and Sedimentation Control (continued)

- The project is highly complex and information is included in the Stormwater Report that explains why it is not possible to submit the Construction Period Pollution Prevention and Erosion and Sedimentation Control Plan with the application. A Construction Period Pollution Prevention and Erosion and Sedimentation Control has **not** been included in the Stormwater Report but will be submitted **before** land disturbance begins.
- The project is **not** covered by a NPDES Construction General Permit.
- The project is covered by a NPDES Construction General Permit and a copy of the SWPPP is in the Stormwater Report.
- The project is covered by a NPDES Construction General Permit but no SWPPP been submitted. The SWPPP will be submitted BEFORE land disturbance begins.

Standard 9: Operation and Maintenance Plan

- The Post Construction Operation and Maintenance Plan is included in the Stormwater Report and includes the following information:
 - Name of the stormwater management system owners;
 - Party responsible for operation and maintenance;
 - Schedule for implementation of routine and non-routine maintenance tasks;
 - Plan showing the location of all stormwater BMPs maintenance access areas;
 - Description and delineation of public safety features;
 - Estimated operation and maintenance budget; and
 - Operation and Maintenance Log Form.
- The responsible party is **not** the owner of the parcel where the BMP is located and the Stormwater Report includes the following submissions:
 - A copy of the legal instrument (deed, homeowner's association, utility trust or other legal entity) that establishes the terms of and legal responsibility for the operation and maintenance of the project site stormwater BMPs;
 - A plan and easement deed that allows site access for the legal entity to operate and maintain BMP functions.

Standard 10: Prohibition of Illicit Discharges

- The Long-Term Pollution Prevention Plan includes measures to prevent illicit discharges;
- An Illicit Discharge Compliance Statement is attached;
- NO Illicit Discharge Compliance Statement is attached but will be submitted **prior to** the discharge of any stormwater to post-construction BMPs.

PROJECT OVERVIEW.

Hudson 62 Realty LLC has recently acquired the parcel of land located at 155 Porter Street in East Boston, MA, the former Sterlingwear of Boston building. The project has undergone review by and received approval from the Boston Planning & Development Agency (BPDA). The project is a redevelopment that intends to renovate the existing building into a boutique hotel with 123 rooms and restaurant, and site improvements including utility connections, resurfaced parking and new landscaped areas.

The project site includes three abutting parcels. The existing 69,496 gross square foot building and parking lot reside on parcel 0103927000. The existing parking lot exists on parcels 0103926000 and 0103928000. The site is located at the southern corner of Porter Street and Orleans Street.

The property falls within the 100-year flood plain and is therefore subject to the jurisdiction of the Boston Conservation Commission. As such, the project must meet the MA Stormwater Management Standards (Standards). Below is a discussion of how each standard is met.

STORMWATER MANAGEMENT STANDARDS

The project will result in a net decrease of impervious area, and therefore qualifies as a Redevelopment as defined in the Standards. Therefore, the project is required to meet the following Stormwater Management Standards only to the maximum extent practicable: Standard 2, Standard 3, and the pretreatment and structural best management practice requirements of Standards 4, 5, and 6. Existing stormwater discharges shall comply with Standard 1 only to the maximum extent practicable. The project will comply with all other requirements of the Standards and improve existing conditions.

Standard 1 – No New Untreated Discharges Causing Erosion

The project will replace and upgrade an existing drainage connection to the City of Boston drainage system. Therefore, no new discharge is created and the Standard is met.

Standard 2 - Peak Rate Attenuation

As a Redevelopment project, there will be a net decrease in impervious area and therefore a reduction in stormwater runoff from the project. In addition, an underground infiltration system is proposed to capture the first 1" of rainfall consistent with the Boston Water and Sewer Commission (BWSC) requirements. As the peak rates and volumes of runoff will be reduced, this Standard is met.

Standard 3 - Annual Recharge to Groundwater

Annual recharge is based on soil type for the project. The NRCS Soils maps note the soil material as "urban land". Based on local knowledge of the area, the native soil material is assumed to be Boston Blue Clay with a hydrologic soil group of D.

To meet Standard 3 for this soil type, a recharge rate of 0.1 x the Total Impervious Area. The Required Recharge Volume (RRV) for the increase in impervious area for the property is as follows:

$$\text{RRV} = 40,290 \text{ SF} \times 0.1 / 12 = \underline{336 \text{ Cubic Feet}}$$

Estimated Annual Recharge provided has been calculated based on the Static Method. This method evaluates the volume of water held beneath the lowest outlet in the proposed recharge system. Based on the HydroCAD model, the Stage-Storage tables for the recharge system demonstrate a volume of 4,007 cubic feet. In addition, the model demonstrates that the system will drain in less than 72 hours (see attached HydroCAD Hydrograph Table). Therefore, the standard is met.

Standard 4 - Water quality

Stormwater management systems shall be designed to remove 80% of the average annual post-construction load of Total Suspended Solids (TSS) to the maximum extent practicable. For all developed watershed areas, greater than 80% TSS removal will be achieved. The system will utilize deep sump catch basins, a proprietary sediment removal system (Stormtech Isolator Row) and subsurface infiltration. Calculations are enclosed with this narrative that demonstrate a 97% TSS Removal Rate.

In addition, a Long Term Pollution Prevention Plan is included at the end of this narrative as part of the Operation & Maintenance Plan.

For the reasons above, the Standard is met.

Standard 5 - Land Uses With Higher Potential Pollutant Loads (LUHPPL)

The proposed uses on the project are not considered LUHPPL's, and therefore the standard does not apply.

Standard 6 - Critical areas

The project does not lie within a Critical Area and therefore the Standard does not apply.

Standard 7 - Redevelopment

As noted, the project qualifies as a Redevelopment. Despite this, the project is able to meet all of the Standards to the full extent.

As the existing property is limited to only catch basin inlets that discharge into the City's drainage system, the proposed drainage design that addresses water quality, groundwater recharge, and runoff quantities is an improvement over existing conditions.

Standard 8 - Construction Period Controls

The project does not disturb more than one acre of land, and therefore is not subject to the NPDES permit. Refer to the Site Preparation Plan prepared by PVI Site Design for Construction Period Controls. In addition, a Narrative of the BMP's to be provided is included in the Operation & Maintenance Plan.

Standard 9 - Long Term Operation and Maintenance Plan

See the Operation and Maintenance Plan attached at the end of this report.

Standard 10 - Illicit Discharges

The project will provide new utility connections to the building. As part of the redevelopment effort, any illicit discharges within the building will be removed during construction.

STORMWATER OPERATION & MAINTENANCE PLAN

155 Porter Street, Boston, MA

Prepared: June 15, 2021

All stormwater BMPs require on-going maintenance to remain effective. In addition, Long Term Pollution Prevention techniques can help prevent pollutants from entering into the drainage system at all. The following is a narrative that addresses Construction Period Stormwater Management, Post Construction Operation and Maintenance, and Long-Term Pollution Prevention methods.

Construction Period Stormwater Controls:

The following are typical best practices that should be implemented during construction:

Minimize Earth Disturbance – The majority of the property is currently paved with asphalt in reasonable condition. Pavement should be kept in place as long as possible to avoid creating of sediment. Pavement should be removed, re-graded and paved in a single sequence to avoid leaving stabilized soil exposed for long periods of time.

Perimeter Controls – Compost Filter Socks or Straw Waddles should be installed at down gradient areas of the property to prevent limit construction runoff from leaving the property. If in landscaped areas, the controls should be set 3" into the ground.

Silt Sacks – Existing Catch Basins should be equipped with silt sacks prior to the start of construction.

Sweeping – Paved Areas should be swept weekly or as needed to removed accumulated sediment. Public Right-of-Ways should inspected daily at the end of the construction day and swept as needed or as directed by the City.

Inspections – The site supervisor should inspect the worksite daily and repair or maintain any BMP's as needed.

Order of Conditions – The project will be subject to an Order of Conditions by the City of Boston Conservation Commission. The Contractor shall be responsible for meeting all Construction Period conditions.

Post Construction – Ongoing Operation and Maintenance

Underground Recharge Systems:

The underground chambers are proposed with two inspection ports, one in the Isolator Row and one in the general recharge area. Inspection ports can be accessed in the event of a problem to inspect the chambers. Periodic inspections of the discharge pipe and chambers should be performed to ensure debris is not entering the system and inhibiting the infiltration capacity of the chambers.

Stormtech Infiltrator Row

The Stormtech Infiltrator Row is a row of Stormtech chambers wrapped in filter fabric. The fabric captures sediment and debris and holds it before infiltration. The row has an inspection port that should be inspected annually to determine the amount of sediment and debris collected. The row can be jet cleaned similar to pipe cleaning methods. It is recommended to contact Stormtech representatives to assist in the cleaning. A specific operation and maintenance manual prepared by Stormtech is enclosed with this document.

Diversion Manhole:

Just upstream of the Recharge System is a special manhole with baffle walls designed to direct low flow to the Infiltrator Row for treatment prior to overflow into the larger recharge system. The manhole should be inspected annually to ensure no debris are inhibiting flow to the isolator row or other sections of the recharge system.

Deep Sump Catch Basins

Catch Basins should be inspected quarterly for the first year to determine the rate of sediment accumulation. Remove sediment and debris when the sump is full within 12" of the bottom of the hood.

Inspection Logs:

Inspection Logs and maintenance records shall be maintained by the owner or owner's association and kept on file for a time period of 3 years.

For further information about the design of the system and on-going maintenance, contact the Engineer of Record:

PVI Site Design, LLC
Attn: Timothy Power, PE
tpower@PVIsitedesign.com
339.206.1030

Long Term Pollution Prevention

There are several potential sources of pollution including gasoline and oil from visiting vehicles, cleaning chemicals, and supplies related to building uses. Other than leaks from vehicles, it is anticipated that these materials will be stored and maintained inside the building, however the following pollution prevention techniques are provided in the event that there is a spill outside the facility that may enter the stormwater management system.

Good House Keeping

The following measures will be employed to control potential sources of contamination and prevent pollution at The Project property:

Deicing

To prevent increased pollutant concentrations in stormwater discharges, the amount of road salt applied will be controlled. Calibration devices for spreaders in trucks will be encouraged to contractors employed to plow the parking area. The amount of deicing materials used will be monitored with the goal of using only enough to make the roadway and parking areas safe. Limiting salt not only benefits the stormwater management system, but also saves on cost of snow and ice removal.

Snow Storage/Disposal

Snow storage/disposal will be allowed in landscaped islands within the property. In large storm events, temporary stockpiles may be generated for off-site disposal following a storm. As a hotel use, each space will need to remain open during the evenings, therefore off-site disposal will be required.

Pavement Sweeping

The project will implement a pavement sweeping program to remove contaminants directly from paved surfaces to prevent their release into the drainage system. Pavement sweeping can be an effective initial treatment for reducing pollutant loadings in stormwater. Once removed from paved surfaces, the sweeping will be handled and disposed of in accordance with the MassDEP's Bureau of Waste Prevention's written policy regarding the reuse and disposal of street sweepings.

Fertilizer/Pesticide/Herbicide Application

No pesticides or herbicides are to be used unless a single spot treatment is required for a specific control application. Fertilizer usage will be avoided. If deemed necessary, slow release fertilizer will be used, and applied only in the minimum amounts recommended by the manufacturer. Once applied, the fertilizer will be worked into the soil to limit exposure to stormwater. Storage will be in a covered area; and the contents of any partially used bags will be transferred to a sealable, plastic bin to avoid spills. Fertilizer will be used to begin the establishment of vegetation in bare or damaged areas, but will not be applied on a regular basis unless necessary.

Materials Management/Housekeeping Practices

The following product-specific practices will be followed on-site. Recommendations are provided for petroleum products, fertilizers, solvents, paints, and other hazardous substances, and concrete.

Petroleum Products - No vehicle maintenance or handling of petroleum products will occur on site outside of a building. Petroleum products will be stored in tightly sealed containers that are clearly labeled. Any asphalt substances used on-site will be applied according to manufacturer's recommendations. No petroleum-based or asphalt substances will be stored within 100 feet of a waterway. Solvents, Paints, and other

Hazardous Substances - All containers will be tightly sealed and stored indoors when not required for use. Excess materials will not be discharged to the storm sewer system, but

will be properly disposed according to manufacturer's instructions or state and local regulations. Outside storage on the property will be prohibited.

Spill Prevention and Control

The Property Manager will be responsible for training of people in the proper handling and cleanup of spilled materials. No spilled hazardous materials or hazardous wastes will be allowed to come in contact with storm water discharges. If such contact occurs, the storm water discharge will be contained on site until appropriate measures in compliance with state and federal regulations are taken to dispose of such contaminated storm water. An "In Case of Emergency or Hazardous Spill" sign with appropriate contact information can be posted in the common area of the residential building.

In order to minimize the potential for a spill of hazardous materials to come into contact with storm water, the following steps will be implemented:

1. All materials with hazardous properties (such as pesticides, petroleum products, fertilizers, detergents, construction chemicals, acids, paints, paint solvents, cleaning solvents, additives for soil stabilization, concrete curing compounds and additives, etc.) will be stored in a secure location, with their lids on, preferably under cover, when not in use.
2. The minimum practical quantity of all such materials will be kept on the site.
3. A spill control and containment kit (containing, for example, absorbent materials, acid neutralizing powder, brooms, dust pans, mops, rags, gloves, goggles, plastic and metal trash containers, etc. will be provided at the maintenance and/or storage area of the site.
4. Manufacturers recommended methods for spill cleanup will be clearly posted and site personnel will be trained regarding these procedures and the location of the information and cleanup supplies.

In the event of a spill, the following procedures should be followed:

1. All spills will be cleaned up immediately after discovery.
2. The spill area will be kept well ventilated and personnel will wear appropriate protective clothing to prevent injury from contact with the hazardous substances.
3. The Owner and Property Manager will be notified immediately.
4. Spills of toxic or hazardous materials will be reported to the appropriate federal, state, and/or local government agency, regardless of the size of the spill.
5. If the spilt material enters the drainage system, the catch basin or other structure acting as the inlet shall be cleaned via a vac truck as soon as possible and before the next rainfall event to the extent practicable.

The Hotel Manager will be the spill prevention and response coordinator. He will designate the individuals who will receive spill prevention and response training. These individuals will each become responsible for a particular phase of prevention and response. The names of these personnel will be posted in the material storage area and other applicable areas onsite.

Isolator[®] Row O&M Manual



THE ISOLATOR[®] ROW

INTRODUCTION

An important component of any Stormwater Pollution Prevention Plan is inspection and maintenance. The StormTech Isolator Row is a technique to inexpensively enhance Total Suspended Solids (TSS) removal and provide easy access for inspection and maintenance.

THE ISOLATOR ROW

The Isolator Row is a row of StormTech chambers, either SC-160LP, SC-310, SC-310-3, SC-740, DC-780, MC-3500 or MC-4500 models, that is surrounded with filter fabric and connected to a closely located manhole for easy access. The fabric-wrapped chambers provide for settling and filtration of sediment as storm water rises in the Isolator Row and ultimately passes through the filter fabric. The open bottom chambers and perforated sidewalls (SC-310, SC-310-3 and SC-740 models) allow storm water to flow both vertically and horizontally out of the chambers. Sediments are captured in the Isolator Row protecting the storage areas of the adjacent stone and chambers from sediment accumulation.

Two different fabrics are used for the Isolator Row. A woven geotextile fabric is placed between the stone and the Isolator Row chambers. The tough geotextile provides a media for storm water filtration and provides a durable surface for maintenance operations. It is also designed to prevent scour of the underlying stone and remain intact during high pressure jetting. A non-woven fabric is placed over the chambers to provide a filter media for flows passing through the perforations in the sidewall of the chamber. The non-woven fabric is not required over the SC-160LP, DC-780, MC-3500 or MC-4500 models as these chambers do not have perforated side walls.

The Isolator Row is typically designed to capture the “first flush” and offers the versatility to be sized on a volume basis or flow rate basis. An upstream manhole not only provides access to the Isolator Row but typically includes a high flow weir such that storm water flowrates or volumes that exceed the capacity of the Isolator Row overtop the overflow weir and discharge through a manifold to the other chambers.

The Isolator Row may also be part of a treatment train. By treating storm water prior to entry into the chamber system, the service life can be extended and pollutants such as hydrocarbons can be captured. Pre-treatment best management practices can be as simple as deep sump catch basins, oil-water separators or can be innovative storm water treatment devices. The design of the treatment train and selection of pretreatment devices by the design engineer is often driven by regulatory requirements. Whether pretreatment is used or not, the Isolator Row is recommended by StormTech as an effective means to minimize maintenance requirements and maintenance costs.

Note: See the StormTech Design Manual for detailed information on designing inlets for a StormTech system, including the Isolator Row.



Looking down the Isolator Row from the manhole opening, woven geotextile is shown between the chamber and stone base.



StormTech Isolator Row with Overflow Spillway (not to scale)

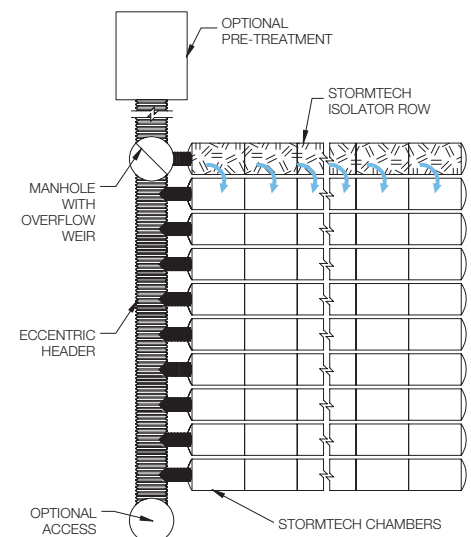



ISOLATOR ROW INSPECTION/MAINTENANCE

INSPECTION

The frequency of inspection and maintenance varies by location. A routine inspection schedule needs to be established for each individual location based upon site specific variables. The type of land use (i.e. industrial, commercial, residential), anticipated pollutant load, percent imperviousness, climate, etc. all play a critical role in determining the actual frequency of inspection and maintenance practices.

At a minimum, StormTech recommends annual inspections. Initially, the Isolator Row should be inspected every 6 months for the first year of operation. For subsequent years, the inspection should be adjusted based upon previous observation of sediment deposition.

The Isolator Row incorporates a combination of standard manhole(s) and strategically located inspection ports (as needed). The inspection ports allow for easy access to the system from the surface, eliminating the need to perform a confined space entry for inspection purposes.

If upon visual inspection it is found that sediment has accumulated, a stadia rod should be inserted to determine the depth of sediment. When the average depth of sediment exceeds 3 inches throughout the length of the Isolator Row, clean-out should be performed.

MAINTENANCE

The Isolator Row was designed to reduce the cost of periodic maintenance. By “isolating” sediments to just one row, costs are dramatically reduced by eliminating the need to clean out each row of the entire storage bed. If inspection indicates the potential need for maintenance, access is provided via a manhole(s) located on the end(s) of the row for cleanout. If entry into the manhole is required, please follow local and OSHA rules for a confined space entries.

Maintenance is accomplished with the JetVac process. The JetVac process utilizes a high pressure water nozzle to propel itself down the Isolator Row while scouring and suspending sediments. As the nozzle is retrieved, the captured pollutants are flushed back into the manhole for vacuuming. Most sewer and pipe maintenance companies have vacuum/JetVac combination vehicles. Selection of an appropriate JetVac nozzle will improve maintenance efficiency. Fixed nozzles designed for culverts or large diameter pipe cleaning are preferable. Rear facing jets with an effective spread of at least 45” are best. Most JetVac reels have 400 feet of hose allowing maintenance of an Isolator Row up to 50 chambers long. **The JetVac process shall only be performed on StormTech Isolator Rows that have AASHTO class 1 woven geotextile (as specified by StormTech) over their angular base stone.**

StormTech Isolator Row (not to scale)

Note: Non-woven fabric is only required over the inlet pipe connection into the end cap for SC-160LP, DC-780, MC-3500 and MC-4500 chamber models and is not required over the entire Isolator Row.

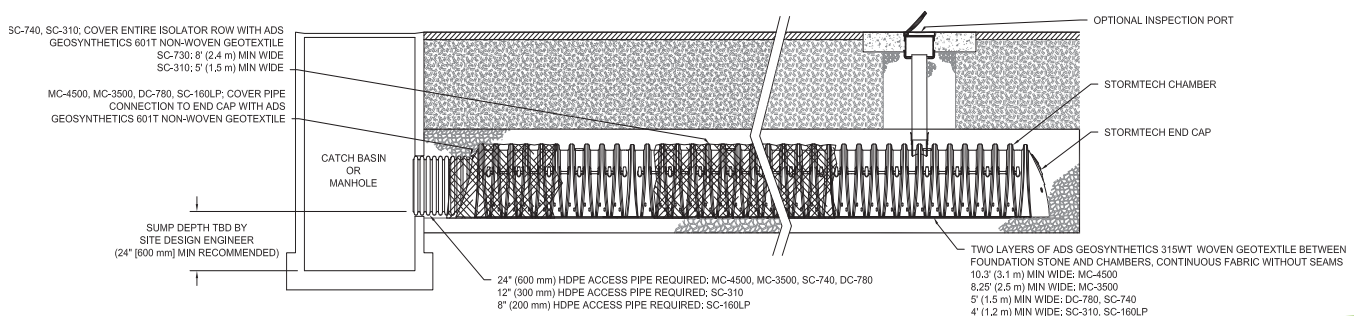

ISOLATOR ROW STEP BY STEP MAINTENANCE PROCEDURES

STEP 1

Inspect Isolator Row for sediment.

- A) Inspection ports (if present)
 - i. Remove lid from floor box frame
 - ii. Remove cap from inspection riser
 - iii. Using a flashlight and stadia rod, measure depth of sediment and record results on maintenance log.
 - iv. If sediment is at or above 3 inch depth, proceed to Step 2. If not, proceed to Step 3.
- B) All Isolator Rows
 - i. Remove cover from manhole at upstream end of Isolator Row
 - ii. Using a flashlight, inspect down Isolator Row through outlet pipe
 - 1. Mirrors on poles or cameras may be used to avoid a confined space entry
 - 2. Follow OSHA regulations for confined space entry if entering manhole
 - iii. If sediment is at or above the lower row of sidewall holes (approximately 3 inches), proceed to Step 2. If not, proceed to Step 3.

STEP 2

Clean out Isolator Row using the JetVac process.

- A) A fixed floor cleaning nozzle with rear facing nozzle spread of 45 inches or more is preferable
- B) Apply multiple passes of JetVac until backflush water is clean
- C) Vacuum manhole sump as required

STEP 3

Replace all caps, lids and covers, record observations and actions.

STEP 4

Inspect & clean catch basins and manholes upstream of the StormTech system.

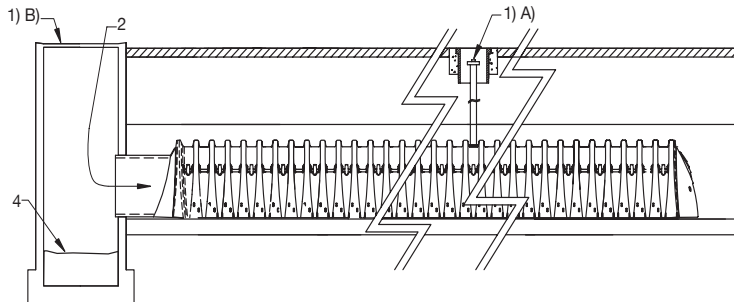

SAMPLE MAINTENANCE LOG

Date	Stadia Rod Readings		Sediment Depth (1)-(2)	Observations/Actions	Inspector
	Fixed point to chamber bottom (1)	Fixed point to top of sediment (2)			
3/15/11	6.3 ft	none		New installation. Fixed point is CI frame at grade	DJM
9/24/11		6.2	0.1 ft	Some grit felt	SM
6/20/13		5.8	0.5 ft	Mucky feel, debris visible in manhole and in Isolator Row, maintenance due	NV
7/7/13	6.3 ft		0	System jetted and vacuumed	DJM

1in Study - 02-07-2018

Prepared by PVI Site Design, LLC

HydroCAD® 10.00-26 s/n 09993 © 2020 HydroCAD Software Solutions LLC

Type III 24-hr 100-YR Rainfall=6.65"

Printed 6/15/2021

Summary for Pond 3P: Underground Chambers

Inflow Area = 1.155 ac, 78.94% Impervious, Inflow Depth > 5.94" for 100-YR event
 Inflow = 7.34 cfs @ 12.08 hrs, Volume= 0.572 af
 Outflow = 7.24 cfs @ 12.10 hrs, Volume= 0.479 af, Atten= 1%, Lag= 0.8 min
 Discarded = 0.00 cfs @ 2.96 hrs, Volume= 0.002 af
 Primary = 7.24 cfs @ 12.10 hrs, Volume= 0.477 af

Routing by Stor-Ind method, Time Span= 1.00-24.00 hrs, dt= 0.02 hrs
 Peak Elev= 12.93' @ 12.10 hrs Surf.Area= 2,393 sf Storage= 4,519 cf

Plug-Flow detention time= 116.9 min calculated for 0.479 af (84% of inflow)
 Center-of-Mass det. time= 50.1 min (815.4 - 765.3)

Volume	Invert	Avail.Storage	Storage Description
#1A	9.50'	1,630 cf	39.50"W x 60.58"L x 3.50"H Field A 8,375 cf Overall - 2,940 cf Embedded = 5,435 cf x 30.0% Voids
#2A	10.00'	2,940 cf	ADS_StormTech SC-740 +Cap x 64 Inside #1 Effective Size= 44.6"W x 30.0"H => 6.45 sf x 7.12'L = 45.9 cf Overall Size= 51.0"W x 30.0"H x 7.56'L with 0.44' Overlap 64 Chambers in 8 Rows
		4,571 cf	Total Available Storage

Storage Group A created with Chamber Wizard

Device	Routing	Invert	Outlet Devices
#1	Primary	10.00'	15.0" Round Culvert L= 40.0' CPP, square edge headwall, Ke= 0.500 Inlet / Outlet Invert= 10.00' / 9.50' S= 0.0125 '/' Cc= 0.900 n= 0.013 Corrugated PE, smooth interior, Flow Area= 1.23 sf
#2	Device 1	12.25'	4.0' long Sharp-Crested Rectangular Weir 2 End Contraction(s) 3.0' Crest Height
#3	Discarded	9.50'	0.020 in/hr Exfiltration over Surface area

Discarded OutFlow Max=0.00 cfs @ 2.96 hrs HW=9.54' (Free Discharge)
 ↳ **3=Exfiltration** (Exfiltration Controls 0.00 cfs)

Primary OutFlow Max=7.22 cfs @ 12.10 hrs HW=12.93' (Free Discharge)
 ↳ **1=Culvert** (Passes 7.22 cfs of 8.96 cfs potential flow)
 ↳ **2=Sharp-Crested Rectangular Weir** (Weir Controls 7.22 cfs @ 2.76 fps)

Stage-Area-Storage for Pond 3P: Underground Chambers

Elevation (feet)	Surface (sq-ft)	Storage (cubic-feet)	Elevation (feet)	Surface (sq-ft)	Storage (cubic-feet)
9.50	2,393	0	12.15	2,393	3,903
9.55	2,393	36	12.20	2,393	3,957
9.60	2,393	72	12.25	2,393	4,007
9.65	2,393	108	12.30	2,393	4,053
9.70	2,393	144	12.35	2,393	4,096
9.75	2,393	179	12.40	2,393	4,136
9.80	2,393	215	12.45	2,393	4,175
9.85	2,393	251	12.50	2,393	4,212
9.90	2,393	287	12.55	2,393	4,248
9.95	2,393	323	12.60	2,393	4,283
10.00	2,393	359	12.65	2,393	4,319
10.05	2,393	454	12.70	2,393	4,355
10.10	2,393	549	12.75	2,393	4,391
10.15	2,393	644	12.80	2,393	4,427
10.20	2,393	739	12.85	2,393	4,463
10.25	2,393	833	12.90	2,393	4,499
10.30	2,393	927	12.95	2,393	4,535
10.35	2,393	1,021	13.00	2,393	4,571
10.40	2,393	1,114			
10.45	2,393	1,207			
10.50	2,393	1,299			
10.55	2,393	1,391			
10.60	2,393	1,482			
10.65	2,393	1,573			
10.70	2,393	1,663			
10.75	2,393	1,753			
10.80	2,393	1,842			
10.85	2,393	1,930			
10.90	2,393	2,018			
10.95	2,393	2,105			
11.00	2,393	2,192			
11.05	2,393	2,278			
11.10	2,393	2,363			
11.15	2,393	2,448			
11.20	2,393	2,531			
11.25	2,393	2,614			
11.30	2,393	2,696			
11.35	2,393	2,777			
11.40	2,393	2,857			
11.45	2,393	2,936			
11.50	2,393	3,014			
11.55	2,393	3,091			
11.60	2,393	3,167			
11.65	2,393	3,242			
11.70	2,393	3,315			
11.75	2,393	3,387			
11.80	2,393	3,457			
11.85	2,393	3,526			
11.90	2,393	3,594			
11.95	2,393	3,660			
12.00	2,393	3,724			
12.05	2,393	3,786			
12.10	2,393	3,846			

INSTRUCTIONS:

Non-automated: Mar. 4, 2008

1. Sheet is nonautomated. Print sheet and complete using hand calculations. Column A and B: See MassDEP Structural BMP Table
2. The calculations must be completed using the Column Headings specified in Chart and Not the Excel Column Headings
3. To complete Chart Column D, multiple Column B value within Row x Column C value within Row
4. To complete Chart Column E value, subtract Column D value within Row from Column C within Row
5. Total TSS Removal = Sum All Values in Column D

Location:

TSS Removal Calculation Worksheet

A BMP ¹	B TSS Removal Rate ¹	C Starting TSS Load*	D Amount Removed (B*C)	E Remaining Load (C-D)
Deep Sump Catch Basin and Hood	25%	1.00	0.25	0.75
Stormtech Infiltrator Row	80%	0.75	0.60	0.15
Subsurface Infiltration System	80%	0.15	0.12	0.03

Total TSS Removal =

97%

Separate Form Needs to be Completed for Each Outlet or BMP Train

Project:
 Prepared By:
 Date:

*Equals remaining load from previous BMP (E) which enters the BMP

Soil Map—Norfolk and Suffolk Counties, Massachusetts
(HOTEL REDEVELOPMENT)



Soil Map may not be valid at this scale.

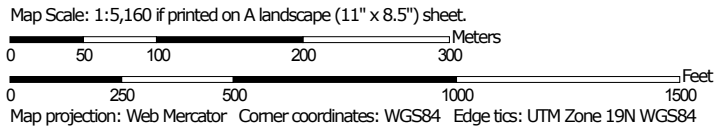

Soil Map—Norfolk and Suffolk Counties, Massachusetts
(HOTEL REDEVELOPMENT)

MAP LEGEND

Area of Interest (AOI)

 Area of Interest (AOI)



















Soils







 Soil Map Unit Polygons

 Soil Map Unit Lines

 Soil Map Unit Points

Special Point Features





-  Blowout
-  Borrow Pit
-  Clay Spot
-  Closed Depression
-  Gravel Pit
-  Gravelly Spot
-  Landfill
-  Lava Flow
-  Marsh or swamp
-  Mine or Quarry
-  Miscellaneous Water
-  Perennial Water
-  Rock Outcrop
-  Saline Spot
-  Sandy Spot
-  Severely Eroded Spot
-  Sinkhole
-  Slide or Slip
-  Sodic Spot

-  Spoil Area
-  Stony Spot
-  Very Stony Spot
-  Wet Spot
-  Other
-  Special Line Features

Water Features

 Streams and Canals

Transportation

-  Rails
-  Interstate Highways
-  US Routes
-  Major Roads
-  Local Roads

Background

 Aerial Photography

MAP INFORMATION

The soil surveys that comprise your AOI were mapped at 1:25,000.

Warning: Soil Map may not be valid at this scale.

Enlargement of maps beyond the scale of mapping can cause misunderstanding of the detail of mapping and accuracy of soil line placement. The maps do not show the small areas of contrasting soils that could have been shown at a more detailed scale.

Please rely on the bar scale on each map sheet for map measurements.

Source of Map: Natural Resources Conservation Service
Web Soil Survey URL:
Coordinate System: Web Mercator (EPSG:3857)

Maps from the Web Soil Survey are based on the Web Mercator projection, which preserves direction and shape but distorts distance and area. A projection that preserves area, such as the Albers equal-area conic projection, should be used if more accurate calculations of distance or area are required.

This product is generated from the USDA-NRCS certified data as of the version date(s) listed below.

Soil Survey Area: Norfolk and Suffolk Counties, Massachusetts
Survey Area Data: Version 12, Sep 15, 2016

Soil map units are labeled (as space allows) for map scales 1:50,000 or larger.

Date(s) aerial images were photographed: Aug 10, 2014—Aug 25, 2014

The orthophoto or other base map on which the soil lines were compiled and digitized probably differs from the background imagery displayed on these maps. As a result, some minor shifting of map unit boundaries may be evident.

Map Unit Legend

Norfolk and Suffolk Counties, Massachusetts (MA616)			
Map Unit Symbol	Map Unit Name	Acres in AOI	Percent of AOI
602	Urban land, 0 to 15 percent slopes	1.7	1.5%
603	Urban land, wet substratum, 0 to 3 percent slopes	86.7	75.2%
655	Udorthents, wet substratum	26.8	23.3%
Totals for Area of Interest		115.2	100.0%

ELEVATION CERTIFICATE

Important: Follow the instructions on pages 1–9.

Copy all pages of this Elevation Certificate and all attachments for (1) community official, (2) insurance agent/company, and (3) building owner.

SECTION A – PROPERTY INFORMATION				FOR INSURANCE COMPANY USE	
A1. Building Owner's Name Hudson 62 Realty LLC				Policy Number:	
A2. Building Street Address (including Apt., Unit, Suite, and/or Bldg. No.) or P.O. Route and Box No. 183 Orleans Street/155 Porter Street				Company NAIC Number:	
City Boston		State Massachusetts		ZIP Code 02128	
A3. Property Description (Lot and Block Numbers, Tax Parcel Number, Legal Description, etc.) Described by deed recorded in Suffolk Registry of Deeds Book 57405, page 192. see attached					
A4. Building Use (e.g., Residential, Non-Residential, Addition, Accessory, etc.) <u>Residential</u>					
A5. Latitude/Longitude: Lat. <u>42 22 17.249</u> Long. <u>W71 2 4.469</u> Horizontal Datum: <input type="checkbox"/> NAD 1927 <input checked="" type="checkbox"/> NAD 1983					
A6. Attach at least 2 photographs of the building if the Certificate is being used to obtain flood insurance.					
A7. Building Diagram Number <u>1A</u>					
A8. For a building with a crawlspace or enclosure(s):					
a) Square footage of crawlspace or enclosure(s) _____ sq ft					
b) Number of permanent flood openings in the crawlspace or enclosure(s) within 1.0 foot above adjacent grade _____					
c) Total net area of flood openings in A8.b _____ sq in					
d) Engineered flood openings? <input type="checkbox"/> Yes <input type="checkbox"/> No					
A9. For a building with an attached garage:					
a) Square footage of attached garage _____ sq ft					
b) Number of permanent flood openings in the attached garage within 1.0 foot above adjacent grade _____					
c) Total net area of flood openings in A9.b _____ sq in					
d) Engineered flood openings? <input type="checkbox"/> Yes <input type="checkbox"/> No					
SECTION B – FLOOD INSURANCE RATE MAP (FIRM) INFORMATION					
B1. NFIP Community Name & Community Number Boston 250286			B2. County Name Suffolk		B3. State Massachusetts
B4. Map/Panel Number 25025C0081	B5. Suffix J	B6. FIRM Index Date	B7. FIRM Panel Effective/ Revised Date 03-16-2016	B8. Flood Zone(s) AE	B9. Base Flood Elevation(s) (Zone AO, use Base Flood Depth) 10
B10. Indicate the source of the Base Flood Elevation (BFE) data or base flood depth entered in Item B9: <input type="checkbox"/> FIS Profile <input checked="" type="checkbox"/> FIRM <input type="checkbox"/> Community Determined <input type="checkbox"/> Other/Source: _____					
B11. Indicate elevation datum used for BFE in Item B9: <input type="checkbox"/> NGVD 1929 <input checked="" type="checkbox"/> NAVD 1988 <input type="checkbox"/> Other/Source: _____					
B12. Is the building located in a Coastal Barrier Resources System (CBRS) area or Otherwise Protected Area (OPA)? <input type="checkbox"/> Yes <input checked="" type="checkbox"/> No Designation Date: _____ <input type="checkbox"/> CBRS <input type="checkbox"/> OPA					

ELEVATION CERTIFICATE

OMB No. 1660-0008
Expiration Date: November 30, 2022

IMPORTANT: In these spaces, copy the corresponding information from Section A.			FOR INSURANCE COMPANY USE
Building Street Address (including Apt., Unit, Suite, and/or Bldg. No.) or P.O. Route and Box No. 183 Orleans Street/155 Porter Street			Policy Number:
City Boston	State Massachusetts	ZIP Code 02128	Company NAIC Number

SECTION C – BUILDING ELEVATION INFORMATION (SURVEY REQUIRED)

C1. Building elevations are based on: Construction Drawings* Building Under Construction* Finished Construction

*A new Elevation Certificate will be required when construction of the building is complete.

C2. Elevations – Zones A1–A30, AE, AH, A (with BFE), VE, V1–V30, V (with BFE), AR, AR/A, AR/AE, AR/A1–A30, AR/AH, AR/AO. Complete Items C2.a–h below according to the building diagram specified in Item A7. In Puerto Rico only, enter meters.

Benchmark Utilized: _____ Vertical Datum: _____

Indicate elevation datum used for the elevations in items a) through h) below.

NGVD 1929 NAVD 1988 Other/Source: GPS observation June 10, 2021

Datum used for building elevations must be the same as that used for the BFE.

Check the measurement used.

- | | | | |
|---|------|--|---------------------------------|
| a) Top of bottom floor (including basement, crawlspace, or enclosure floor) _____ | 12.2 | <input checked="" type="checkbox"/> feet | <input type="checkbox"/> meters |
| b) Top of the next higher floor _____ | 26.3 | <input checked="" type="checkbox"/> feet | <input type="checkbox"/> meters |
| c) Bottom of the lowest horizontal structural member (V Zones only) _____ | | <input type="checkbox"/> feet | <input type="checkbox"/> meters |
| d) Attached garage (top of slab) _____ | | <input type="checkbox"/> feet | <input type="checkbox"/> meters |
| e) Lowest elevation of machinery or equipment servicing the building
(Describe type of equipment and location in Comments) _____ | 3.8 | <input checked="" type="checkbox"/> feet | <input type="checkbox"/> meters |
| f) Lowest adjacent (finished) grade next to building (LAG) _____ | 10.5 | <input checked="" type="checkbox"/> feet | <input type="checkbox"/> meters |
| g) Highest adjacent (finished) grade next to building (HAG) _____ | 21.5 | <input checked="" type="checkbox"/> feet | <input type="checkbox"/> meters |
| h) Lowest adjacent grade at lowest elevation of deck or stairs, including structural support _____ | 12.2 | <input checked="" type="checkbox"/> feet | <input type="checkbox"/> meters |

SECTION D – SURVEYOR, ENGINEER, OR ARCHITECT CERTIFICATION

This certification is to be signed and sealed by a land surveyor, engineer, or architect authorized by law to certify elevation information. I certify that the information on this Certificate represents my best efforts to interpret the data available. I understand that any false statement may be punishable by fine or imprisonment under 18 U.S. Code, Section 1001.

Were latitude and longitude in Section A provided by a licensed land surveyor? Yes No Check here if attachments.

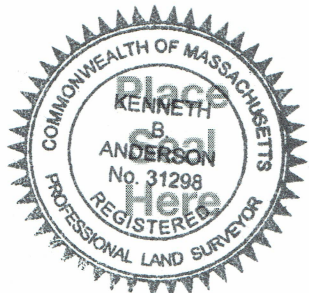
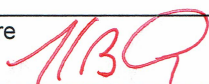
Certifier's Name Kenneth B. Anderson	License Number 31298		
Title Professional Land Surveyor			
Company Name Anderson Surveys, Inc.			
Address 800 High Street			
City Hanson	State Massachusetts		ZIP Code 02341
Signature 	Date 06-15-2021	Telephone (781) 293-3349	Ext.

Copy all pages of this Elevation Certificate and all attachments for (1) community official, (2) insurance agent/company, and (3) building owner.

Comments (including type of equipment and location, per C2(e), if applicable)
Lowest elevation in building is bottom of elevator shaft. Outside ground elevation at shaft is above 15 feet

ELEVATION CERTIFICATE

OMB No. 1660-0008
Expiration Date: November 30, 2022

IMPORTANT: In these spaces, copy the corresponding information from Section A.			FOR INSURANCE COMPANY USE
Building Street Address (including Apt., Unit, Suite, and/or Bldg. No.) or P.O. Route and Box No. 183 Orleans Street/155 Porter Street			Policy Number:
City Boston	State Massachusetts	ZIP Code 02128	Company NAIC Number

SECTION E – BUILDING ELEVATION INFORMATION (SURVEY NOT REQUIRED) FOR ZONE AO AND ZONE A (WITHOUT BFE)

For Zones AO and A (without BFE), complete Items E1–E5. If the Certificate is intended to support a LOMA or LOMR-F request, complete Sections A, B, and C. For Items E1–E4, use natural grade, if available. Check the measurement used. In Puerto Rico only, enter meters.

- E1. Provide elevation information for the following and check the appropriate boxes to show whether the elevation is above or below the highest adjacent grade (HAG) and the lowest adjacent grade (LAG).
- a) Top of bottom floor (including basement, crawlspace, or enclosure) is _____ feet meters above or below the HAG.
- b) Top of bottom floor (including basement, crawlspace, or enclosure) is _____ feet meters above or below the LAG.
- E2. For Building Diagrams 6–9 with permanent flood openings provided in Section A Items 8 and/or 9 (see pages 1–2 of Instructions), the next higher floor (elevation C2.b in the diagrams) of the building is _____ feet meters above or below the HAG.
- E3. Attached garage (top of slab) is _____ feet meters above or below the HAG.
- E4. Top of platform of machinery and/or equipment servicing the building is _____ feet meters above or below the HAG.
- E5. Zone AO only: If no flood depth number is available, is the top of the bottom floor elevated in accordance with the community's floodplain management ordinance? Yes No Unknown. The local official must certify this information in Section G.

SECTION F – PROPERTY OWNER (OR OWNER'S REPRESENTATIVE) CERTIFICATION

The property owner or owner's authorized representative who completes Sections A, B, and E for Zone A (without a FEMA-issued or community-issued BFE) or Zone AO must sign here. The statements in Sections A, B, and E are correct to the best of my knowledge.

Property Owner or Owner's Authorized Representative's Name

Address _____ City _____ State _____ ZIP Code _____

Signature _____ Date _____ Telephone _____

Comments

Check here if attachments.

ELEVATION CERTIFICATE

OMB No. 1660-0008
Expiration Date: November 30, 2022

IMPORTANT: In these spaces, copy the corresponding information from Section A.			FOR INSURANCE COMPANY USE
Building Street Address (including Apt., Unit, Suite, and/or Bldg. No.) or P.O. Route and Box No. 183 Orleans Street/155 Porter Street			Policy Number:
City Boston	State Massachusetts	ZIP Code 02128	Company NAIC Number

SECTION G – COMMUNITY INFORMATION (OPTIONAL)

The local official who is authorized by law or ordinance to administer the community's floodplain management ordinance can complete Sections A, B, C (or E), and G of this Elevation Certificate. Complete the applicable item(s) and sign below. Check the measurement used in Items G8–G10. In Puerto Rico only, enter meters.

- G1. The information in Section C was taken from other documentation that has been signed and sealed by a licensed surveyor, engineer, or architect who is authorized by law to certify elevation information. (Indicate the source and date of the elevation data in the Comments area below.)
- G2. A community official completed Section E for a building located in Zone A (without a FEMA-issued or community-issued BFE) or Zone AO.
- G3. The following information (Items G4–G10) is provided for community floodplain management purposes.

G4. Permit Number	G5. Date Permit Issued	G6. Date Certificate of Compliance/Occupancy Issued
-------------------	------------------------	---

G7. This permit has been issued for: New Construction Substantial Improvement

G8. Elevation of as-built lowest floor (including basement) of the building: _____ feet meters Datum _____

G9. BFE or (in Zone AO) depth of flooding at the building site: _____ feet meters Datum _____

G10. Community's design flood elevation: _____ feet meters Datum _____

Local Official's Name	Title
-----------------------	-------

Community Name	Telephone
----------------	-----------

Signature	Date
-----------	------

Comments (including type of equipment and location, per C2(e), if applicable)

Check here if attachments.

BUILDING PHOTOGRAPHS

See Instructions for Item A6.

OMB No. 1660-0008

Expiration Date: November 30, 2022

ELEVATION CERTIFICATE

IMPORTANT: In these spaces, copy the corresponding information from Section A.			FOR INSURANCE COMPANY USE
Building Street Address (including Apt., Unit, Suite, and/or Bldg. No.) or P.O. Route and Box No. 183 Orleans Street/155 Porter Street			Policy Number:
City Boston	State Massachusetts	ZIP Code 02128	Company NAIC Number

If using the Elevation Certificate to obtain NFIP flood insurance, affix at least 2 building photographs below according to the instructions for Item A6. Identify all photographs with date taken; "Front View" and "Rear View"; and, if required, "Right Side View" and "Left Side View." When applicable, photographs must show the foundation with representative examples of the flood openings or vents, as indicated in Section A8. If submitting more photographs than will fit on this page, use the Continuation Page.



Photo One

Photo One Caption End view

Clear Photo One



Photo Two

Photo Two Caption Street view

Clear Photo Two

ELEVATION CERTIFICATE

BUILDING PHOTOGRAPHS

Continuation Page

OMB No. 1660-0008

Expiration Date: November 30, 2022

IMPORTANT: In these spaces, copy the corresponding information from Section A.			FOR INSURANCE COMPANY USE
Building Street Address (including Apt., Unit, Suite, and/or Bldg. No.) or P.O. Route and Box No. 183 Orleans Street/155 Porter Street			Policy Number:
City Boston	State Massachusetts	ZIP Code 02128	Company NAIC Number

If submitting more photographs than will fit on the preceding page, affix the additional photographs below. Identify all photographs with: date taken; "Front View" and "Rear View"; and, if required, "Right Side View" and "Left Side View." When applicable, photographs must show the foundation with representative examples of the flood openings or vents, as indicated in Section A8.

Photo Three

Photo Three

Photo Three Caption

Clear Photo Three

Photo Four

Photo Four

Photo Four Caption

Clear Photo Four



2017 00002556

Bk: 57405 Pg: 192 Page: 1 of 4

Recorded: 01/10/2017 11:43 AM

ATTEST: Stephen J. Murphy, Register

Suffolk County Registry of Deeds

MASSACHUSETTS EXCISE TAX
Suffolk County District ROD # 001

Date: 01/10/2017 11:43 AM

Ctil# 166572 16308 Doc# 00002556

Fee: \$67,260.00 Cons: \$14,750,000.00

Prepared by:

Bruce I. Miller, Esq.
Pierce Atwood, LLP
100 Summer Street – Suite 2250
Boston, MA 02110

QUITCLAIM DEED

183 ORLEANS STREET LLC, a Massachusetts limited liability company (“**Grantor**”), whose address is 74 Clarendon Street, Suite A, Boston, MA, for consideration paid, and in full consideration of FOURTEEN MILLION SEVEN HUNDRED FIFTY THOUSAND DOLLARS (\$14,750,000.00), hereby grants to **HUDSON 62 REALTY LLC**, a Massachusetts limited liability company (“**Grantee**”), whose address is 7 Musket Lane, Sudbury, MA 01776.

WITH QUITCLAIM COVENANTS:

The following described premises:

151-155 Porter Street, East Boston

The land in Boston, Suffolk County, being five certain parcels of lots situated in that part of Boston called East Boston being lots 21 through 25 inclusive as shown on Plan entitled ‘Plan of East Boston Company, Lots, Section 5, Block 54’, made by Edward P. Adams, Engineer, dated May 15, 1905, and recorded with Suffolk Deeds, Book 3046, Page 340, bounded and described and measured as follows:

Lot 23: Beginning at a point in the Northerly side line of Frankfort Street, Fifty-Seven 58/100 (57.58) feet from the Northwesterly Corner of Frankfort and Porter Streets, thence running Northwesterly at right angles to said line of Frankfort Street and bounded Easterly by Lot numbered 22, One Hundred 00/100 (100.00) feet to a point, thence Southwesterly at right angle and bounded Northerly by Lots numbered 18 and 19, Twenty-Eight 82/100 (28.82) feet to a point, thence Southeasterly at right angles, parallel to the line first above described, and bounded Westerly by lot, number 24, One line of Frankfort Street, thence Northeasterly along said line to Frankfort Street, Twenty-Eight 82/100 (28.82) feet to the point of beginning, containing 2,882 square feet of land, more or less.

Lot 24: Beginning at a point in the Northerly side of Frankfort Street, Eighty-Six 40/100 (86.40) feet from the Northwesterly corner of Frankfort and Porter Streets, thence running Northwesterly at right angles to said line of Frankfort Street, and bounded Easterly by Lot numbered 23, One Hundred 00/100 (100.00) feet to a point, thence Southwesterly at right angles and bounded Northerly by Lots numbered 17 and 18, Twenty-Eight 82/100 (28.82) feet to a point, thence Southeasterly at right angles, parallel to the line first above described, and bounded Westerly by

Lot, numbered 25, One Hundred 00/100 (100.00) feet to a point in the Northerly side line of Frankfort Street, Twenty-Eight 82/100 (28.82) feet to a point of beginning, containing 2,882 square feet of land, more or less.

Lot 25: Beginning at the Southwesterly corner of said Lot 24, thence Northwesterly at right angles, One Hundred 00/100 (100.00) feet thence Southwesterly at right angles Twenty-Eight 82/100 (28.82) feet, thence Southwesterly at right angles, One Hundred 00/100 (100.00) feet to northerly side of Frankfort Street, thence, Northeasterly along said line of Frankfort Street, Twenty-Eight (28.82) feet to the point of beginning, containing 2,882 feet, more or less.

Parcel #1: About Twenty-Eight Hundred Seventy-Six (2876) square feet of land on the Northwesterly side of Frankfort Street, adjoining another estate now or formerly of said Lorenzo DiGuisto, being Lot Twenty-One (21), Edward P. Adams, Plan dated May 15, 1905, recorded with Suffolk Deeds, Book 3046, Page 340, Block 54, Section 5, East Boston District.

Parcel #2: About Twenty-Eight Hundred Eighty-Two (2,882) square feet of land on the Northwesterly side of Frankfort Street, adjoining another estate now or formerly of said Lorenzo DiGuisto being Lot Twenty-Two (22) Edward P. Adams, Plan dated May 15, 1905, recorded with Suffolk Deeds, Book 3046, Page 340, Block 34, Section 5, East Boston District.

For title reference see Deed from Edward Burke, Trustee of Porterfrank Realty Trust dated February 15, 2016, recorded with Suffolk County Registry of Deeds immediately prior hereto.

183 Orleans Street, East Boston

The land at 183 Orleans Street, East Boston, Suffolk County, Massachusetts, consisting of two parcels of land, bounded and described as follows:

First Parcel:

Northwesterly	by Orleans Street, two hundred twenty (220) feet;
Northeasterly	by Porter Street, one hundred (100) feet;
Southeasterly	by a line parallel to the southeasterly line of Orleans Street and one hundred feet distant therefrom, two hundred twenty (220) feet; and
Southwesterly	by land now or formerly of Howard S. Cosgrove, one hundred feet (100) feet.

Second Parcel:

Commencing at a point on Orleans Street, two hundred twenty (220) feet from the southwest corner of Porter and Orleans Streets; thence running at right angles and

Southeasterly a distance of one hundred (100) feet; thence running

Westerly and parallel with Orleans Street a distance of one hundred forty (140) feet; thence running at right angles and

Northwesterly a distance of one hundred (100) feet; thence running

Northeasterly along the southeasterly side of Orleans Street, a distance of one hundred forty (140) feet to the point of beginning.

For title reference see Deed dated October 7, 2013, recorded with Suffolk County Registry of Deeds in Book 52219, Page 157.

The Grantor has not elected to be treated as a corporation for federal income tax purposes.

[SIGNATURES APPEAR ON FOLLOWING PAGE]

IN WITNESS WHEREOF, Grantor has executed and delivered this Quitclaim Deed as of this 13 day of November, 2016.

183 ORLEANS STREET LLC,
a Massachusetts limited liability company

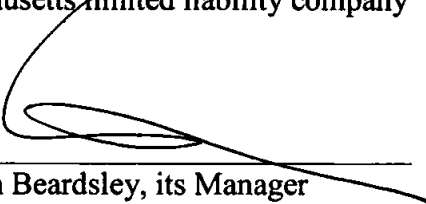
By: 
Keith Beardsley, its Manager

COMMONWEALTH OF MASSACHUSETTS)
COUNTY OF SUFFOLK)

On this 13th day of November, 2016, before me, the undersigned notary public, personally appeared Keith Beardsley, in his capacity as the Manager of 183 Orleans Street LLC, a Massachusetts limited liability company, who proved to me through satisfactory evidence of identification, which was: a picture driver's license from MASS, or other form of photo identification, to wit _____, or personally known to the undersigned Notary Public, to be the person whose name is signed in such capacity on the preceding or attached document, and acknowledged to me that he signed it voluntarily for its stated purpose as his free and voluntary act and deed on behalf of 183 Orleans Street LLC.

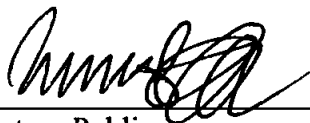

Notary Public
My commission expires:



BRUCE I. MILLER
Notary Public
Commonwealth of Massachusetts
My Commission Expires
August 2, 2018

ILLICIT DISCHARGE COMPLIANCE STATEMENT
155 Porter Street, East Boston, MA

In accordance with the Wetland Regulations found in 310 CMR 10.05(6) and the Massachusetts Stormwater Handbook published by the Massachusetts Department of Environmental Protection, the stormwater management system for the proposed project located at 155 Porter Street in East Boston, Massachusetts shall accept no illicit discharges. Illicit discharges are defined as discharges not entirely comprised of stormwater and include, but are not limited to, wastewater discharges and discharges of stormwater contaminated by contact with process wastes, raw materials, toxic pollutants, hazardous substances, oil, or grease.

PVI Site Design, LLC has performed an investigation of the existing site conditions and record plans and did not find any illicit discharges. Prior to and during construction, additional investigations will take place to identify and remove any and all illicit discharges currently onsite. These actions include, without limitation, visual screening, dye or smoke testing, and the removal of any sources of illicit discharges to the stormwater management system.

Should any illicit discharges enter the stormwater management system after construction has been completed, immediate steps to remove the discharges and their source shall be taken to return the system to its proper working state.

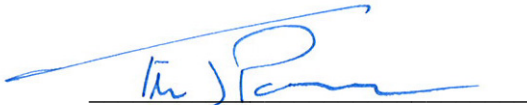

Timothy J. Power, PE
For PVI Site Design, LLC

July 13, 2021

Date

NOTE: Project filings should be prepared and submitted using the online [Climate Resiliency Checklist](#).

A.1 - Project Information

Project Name:	Boston Hotel		
Project Address:	155 Porter Street, Boston, MA 02128		
Project Address Additional:			
Filing Type (select)	Building Permit (prior to final design approval)		
Filing Contact	Utkarsh Patil	Russell and Dawson	utkarsh.patil@rda ep.com (860) 289-1100
Is MEPA approval required	No		3/14/2018

A.3 - Project Team

Owner / Developer:	Russell and Dawson
Architect:	Russell and Dawson
Engineer:	Russell and Dawson
Sustainability / LEED:	The Green Engineer, Inc.
Permitting:	Epsilon
Construction Management:	TBD

A.3 - Project Description and Design Conditions

List the principal Building Uses:	Hotel
List the First Floor Uses:	Front Desk, Dining, Amenity, BOH
List any Critical Site Infrastructure and or Building Uses:	

Site and Building:

Site Area:	50, 328 SF	Building Area:	64709 SF
Building Height:	71'-3"Ft	Building Height:	5 Stories
Existing Site Elevation - Low:	14.8 Ft BCB	Existing Site Elevation - High:	25.89 Ft BCB
Proposed Site Elevation - Low:	10.0 Ft BCB	Proposed Site Elevation - High:	25.89 Ft BCB
Proposed First Floor Elevation:	18.2 Ft BCB	Below grade levels:	6 Stories

Article 37 Green Building:

LEED Version - Rating System :	LEED NC-v4	LEED Certification:	Yes
Proposed LEED rating:	Silver	Proposed LEED point score:	58 Pts.

Building Envelope

When reporting R values, differentiate between R discontinuous and R continuous. For example, use “R13” to show R13 discontinuous and use R10c.i. to show R10 continuous. When reporting U value, report total assembly U value including supports and structural elements.

Roof:	R-31.25	Exposed Floor:	Not insulated
Foundation Wall:	N/A	Slab Edge (at or below grade):	Not insulated

Vertical Above-grade Assemblies (%'s are of total vertical area and together should total 100%):

Area of Opaque Curtain Wall & Spandrel Assembly:	0(%)	Wall & Spandrel Assembly Value:	R-11.76
Area of Framed & Insulated / Standard Wall:	39.78 (%)	Wall Value	R-11.76
Area of Vision Window:	60(%)	Window Glazing Assembly Value:	U-0.3
		Window Glazing SHGC:	SHGC = 0.37
Area of Doors:	0.22%	Door Assembly Value:	0.3(U)

Energy Loads and Performance

For this filing – describe how energy loads & performance were determined

The performance and the overall energy use was estimated using eQUEST energy modeling tool based on the information provided by the design team.

Annual Electric:	727,966 kWh	Peak Electric:	748.8(kW)
Annual Heating:	1,083 MMbtu	Peak Heating:	1.73(MMbtu)
Annual Cooling:	193 MMbtu	Peak Cooling:	150(Tons)
Energy Use - Below ASHRAE 90.1 - 2013:	8.3 %	Have the local utilities reviewed the building energy performance?	Yes
Energy Use - Below Mass. Code:	8.3 %	Energy Use Intensity:	56.7 kBtu/SF

Back-up / Emergency Power System

Electrical Generation Output:	125 kW	Number of Power Units:	Two
System Type:	Emergency power application	Fuel Source:	Natural gas

Emergency and Critical System Loads (in the event of a service interruption)

Electric:	88.9(kW)	Heating:	0 MMbtu/hr
		Cooling:	0 Tons/hr

B – Greenhouse Gas Reduction and Net Zero / Net Positive Carbon Building Performance

Reducing GHG emissions is critical to avoiding more extreme climate change conditions. To achieve the City's goal of carbon neutrality by 2050 new buildings performance will need to progressively improve to net carbon zero and positive.

B.1 – GHG Emissions - Design Conditions

For this Filing - Annual Building GHG Emissions: 311(Tons)

For this filing - describe how building energy performance has been integrated into project planning, design, and engineering and any supporting analysis or modeling:

The project team used energy modeling during the design phases to identify appropriate energy efficiency targets

Describe building specific passive energy efficiency measures including orientation, massing, envelop, and systems:

The building has a high-performance glazing system

Describe building specific active energy efficiency measures including equipment, controls, fixtures, and systems:

The design includes high efficiency MEP systems and local controls, reduced LPD fixtures and a BAS for effective and efficient control of systems.

Describe building specific load reduction strategies including on-site renewable, clean, and energy storage systems:

The building uses high efficiency VRV hvac systems for heating and cooling, combined with LED fixtures for energy efficiency. The big windows in all rooms provides ample natural light and reduces lighting load.

Describe any area or district scale emission reduction strategies including renewable energy, central energy plants, distributed energy systems, and smart grid infrastructure:

Describe any energy efficiency assistance or support provided or to be provided to the project:

The project is pursuing incentives through the MassSave program

B.2 - GHG Reduction - Adaptation Strategies

Describe how the building and its systems will evolve to further reduce GHG emissions and achieve annual carbon net zero and net positive performance (e.g. added efficiency measures, renewable energy, energy storage, etc.) and the timeline for meeting that goal (by 2050):

In the future, when the base building systems components need to be replaced the new components will be state of the art (at the time) and in all likelihood more energy efficient than the initial systems.

C - Extreme Heat Events

Annual average temperature in Boston increased by about 2° F in the past hundred years and will continue to rise due to climate change. By the end of the century, the average annual temperature could be 56° (compared to 46° now) and the number of days above 90° (currently about 10 a year) could rise to 90.

C.1 – Extreme Heat - Design Conditions

Temperature Range - Low:	6 Deg.	Temperature Range - High:	91 Deg.
Annual Heating Degree Days:	5596	Annual Cooling Degree Days	750

What Extreme Heat Event characteristics will be / have been used for project planning

Days - Above 90°:	14	Days – Above 100°:	0
Number of Heatwaves / Year:	3	Average Duration of Heatwave (Days):	0

Describe all building and site measures to reduce heat-island effect at the site and in the surrounding area:

We have maximized the green space on the site by introducing landscape and green roof on the building.

C.2 - Extreme Heat – Adaptation Strategies

Describe how the building and its systems will be adapted to efficiently manage future higher average temperatures, higher extreme temperatures, additional annual heatwaves, and longer heatwaves:

The building utilizes low-e window glazing, combined with low energy consumption hvac units.

Describe all mechanical and non-mechanical strategies that will support building functionality and use during extended interruptions of utility services and infrastructure including proposed and future adaptations:

To prepare for future power interruptions, future adaptations can be made to equip the building hvac with generator backup and install solar panels on the roof and as carports in the parking lot.

D - Extreme Precipitation Events

From 1958 to 2010, there was a 70 percent increase in the amount of precipitation that fell on the days with the heaviest precipitation. Currently, the 10-Year, 24-Hour Design Storm precipitation level is 5.25". There is a significant probability that this will increase to at least 6" by the end of the century. Additionally, fewer, larger storms are likely to be accompanied by more frequent droughts.

D.1 – Extreme Precipitation - Design Conditions

10 Year, 24 Hour Design Storm:	4.6 In.
--------------------------------	---------

Describe all building and site measures for reducing storm water run-off:

The site design reduces the overall impervious area of the site. A new stormwater infiltration system is proposed to infiltrate the first 1" or rainfall.

D.2 - Extreme Precipitation - Adaptation Strategies

Describe how site and building systems will be adapted to efficiently accommodate future more significant rain events (e.g. rainwater harvesting, on-site storm water retention, bio swales, green roofs):

The site utilizes on-site retention to reduce runoff from leaving the property.

E – Sea Level Rise and Storms

Under any plausible greenhouse gas emissions scenario, sea levels in Boston will continue to rise throughout the century. This will increase the number of buildings in Boston susceptible to coastal flooding and the likely frequency of flooding for those already in the floodplain.

Is any portion of the site in a FEMA SFHA?	Yes	What Zone:	AE
		Current FEMA SFHA Zone Base Flood Elevation:	16.46 Ft BCB

Is any portion of the site in a BPDA Sea Level Rise - Flood Hazard Area? Use the online BPDA SLR-FHA Mapping Tool to assess the susceptibility of the project site.	Yes
---	-----

If you answered YES to either of the above questions, please complete the following questions. Otherwise you have completed the questionnaire; thank you!

E.1 – Sea Level Rise and Storms – Design Conditions

Proposed projects should identify immediate and future adaptation strategies for managing the flooding scenario represented on the BPDA Sea Level Rise - Flood Hazard Area (SLR-FHA) map, which depicts a modeled 1% annual chance coastal flood event with 40 inches of sea level rise (SLR). Use the online [BPDA SLR-FHA Mapping Tool](#) to identify the highest Sea Level Rise - Base Flood Elevation for the site. The Sea Level Rise - Design Flood Elevation is determined by adding either 24” of freeboard for critical facilities and infrastructure and any ground floor residential units OR 12” of freeboard for other buildings and uses.

Sea Level Rise - Base Flood Elevation:	19.3 Ft BCB		
Sea Level Rise - Design Flood Elevation:	20.3 Ft BCB	First Floor Elevation:	18.2 Ft BCB
Site Elevations at Building:	18.2 Ft BCB	Accessible Route Elevation:	18.2 Ft BCB

Describe site design strategies for adapting to sea level rise including building access during flood events, elevated site areas, hard and soft barriers, wave / velocity breaks, storm water systems, utility services, etc.:

One of the exit stairs currently discharges at 25.9 BCB. The other exit stair will have provisions to exit above sea level rise DFE.

Describe how the proposed Building Design Flood Elevation will be achieved including dry / wet flood proofing, critical systems protection, utility service protection, temporary flood barriers, waste and drain water back flow prevention, etc.:

The building gk]H[W [YUfzHfUbgZcfa Yf UbX [YbYfUrcf k]`VY`d`UWX`cb U`&(`\`][\` d`Uhzfa `tc`a`YYhXZY`fYei`jFYa`Ybrg`"Electrical panels from basement relocated.

Describe how occupants might shelter in place during a flooding event including any emergency power, water, and wastewater provisions and the expected availability of any such measures:

The building is equipped with backup generators and there is a possibility of having solar energy in the future that would support shelter taken by occupants during any emergency situations.

Describe any strategies that would support rapid recovery after a weather event:

The existing building is cast-in-place concrete which is inherently resistant to the weather adversities.

E.2 – Sea Level Rise and Storms – Adaptation Strategies

Describe future site design and or infrastructure adaptation strategies for responding to sea level rise including future elevating of site areas and access routes, barriers, wave / velocity breaks, storm water systems, utility services, etc.:

To cope with sea level rise, there is a future possibility of raising the first-floor level by 2'. The site design would follow along on the possibility of raising the site areas. The ample floor to floor height of the existing building would allow this change to be possible.

Describe future building adaptation strategies for raising the Sea Level Rise Design Flood Elevation and further protecting critical systems, including permanent and temporary measures:

K Y'dfcdcgY`Yj Uh]b[`Vi]X]b[`gk]hW[YUfz[YbYfUhc'UbX'hfUbgZcfa Yf'cb'U'&(' high concrete platform and modify stair 2 for raising floor above future BFE.

A pdf and word version of the Climate Resiliency Checklist is provided for informational use and off-line preparation of a project submission. **NOTE: Project filings should be prepared and submitted using the online [Climate Resiliency Checklist](#).**

For questions or comments about this checklist or Climate Change best practices, please contact: John.Dalzell@boston.gov



Climate Change Narrative and Flood Design Affidavit

June 29, 2021

Hotel Redevelopment
175 Orleans Street
East Boston, Massachusetts
File No. 16155.01

In construction, the best thing one can do for the environment is reuse an existing building. Russell and Dawson is proposing, on behalf of our client Hudson 62 Realty LLC, to make adaptive reuse of an existing 5-story factory building as a 123-room hotel with loft style guest suites. The original floor area and building envelope will remain with cosmetic repairs to the façade and new, more energy-efficient windows that recreate the historic appearance. In order to comply with Conservation Commission guidelines, we have proposed several measures to minimize the effect of climate change on this proposed development.

Due to the increase of greenhouse gases resulting from human activity in the atmosphere, what we expect of the northeast climate in five years or ten years is changing from what we expect next year. Climate change can be expected to have a number of effects that may impact this property, including a lack of rain or an excess of rain, a general increase or decrease in temperature, greater extremes of temperature both hot and cold, greater frequency and intensity of hurricanes and other storms, exposure to additional pandemic diseases, and sea level rise.

Climate Equity and Environmental Justice

This project will be air conditioned. In a city, anyone able to afford air conditioning dumps their excess heat on those who cannot afford it. This changes the microclimate and may result in some minor additional discomfort, but in a prolonged heat wave it might have more adverse effects. The only way we can think of to avoid this issue is to dump the heat to groundwater with a geothermal heat pump, but that does not appear to be practical on this site. Per HomeArea.com, of the 14 cities in Massachusetts Boston has the most income inequality and it is increasing. Changes to the system of income maintenance subsidies and taxation that would reduce this inequality to the point that the difference in effects of environmental degradation on the poor and the rich would be de minimis is beyond the scope of this project.



Discussion of Climate Resiliency Measures

The resilience of this development and the resilience of what lies beyond it are not the same. For instance, it is possible to raise the grade of the entire site by 24” right now. That would preserve the development through the worst predictions of sea level rise. However, that would increase flooding in the areas around it that do not have the opportunity to make the same change. The best strategy for both this property and the surrounding properties is to anticipate that an increase in the floor level of the first floor may be necessary at some time in the distant future. The surface parking may flood but will not be adversely affected as the waters recede. In response to considerations of resilience we are making the following changes now that would maximize current resilience and minimize the future cost of raising the first floor: revising the section of the exit stair that discharges to the lower grade so that egress may continue to pass below the landing, raise the exterior generator and transformer platforms 24”, raise the housekeeping pad of the interior electrical switchgear 24”, and move the cellular equipment presently planned for the basement to a higher floor. Although there will be considerable expense in raising the first-floor level if it came to that, it is possible to just extend the sanitary connections, while electrical service cables must be continuous and would have to be replaced.

The spread of infectious disease is even more variable than the potential for flooding. Fresh air will be provided by a central system, but heating and cooling are handled room by room, so spread of disease via the HVAC system is unlikely. Interior finishes are readily cleanable. We are not proposing shields at service areas as these have proved easy to install should they be required.

The exterior envelope and HVAC system have been designed to comply with current requirements for heating and cooling. They will be able to handle occasional extremes outside the design temperatures. Should the mean temperature increase substantially, it might be necessary to introduce additional cooling capacity, but there is no reason to increase it now. The exterior envelope has been designed to comply with current requirements for insulation and for wind loading. We find no estimates of a potential for increased wind loading. Insulation performance will be augmented by changes to the HVAC system should that be needed as discussed above.

Although New England is currently in a drought, previous droughts such as that from 1962 to 1966 have been more serious and were survived without recourse to measures such as rainwater collection in a cistern. We can use a lot less water than we do, and the inhabitants of New England have demonstrated their attention to and compliance with rules such as those that might be promulgated for usage reduction should that become necessary. Also, technology that reduces water usage has become widespread since 1966 and is incorporated in this building.

We hope this information is helpful.

Very truly yours,

RUSSELL AND DAWSON INC.



Thomas A. Manning, VP - Architectural

Duly Authorized



**City of Boston
Board of Appeal**

Inspectional Services Department
1010 Massachusetts Avenue
Boston, MA 02118
617-635-4775

Members

Christine Araujo - *Chair*
Bruce Bickerstaff
Mark Fortune - *Secretary*
Peter Chin
Mark Erlich
Anthony Pisani, AIA
Craig Galvin

**NOTICE OF DECISION
CASE NO. BOA889510
PERMIT #ALT878760
APPEAL SUSTAINED
WITH PROVISOS**

In reference to appeal of

Hudson 62 Realty, LLC

concerning premises

155 Porter Street, Ward 01

to vary the application of the Zoning Act, Ch. 665, Acts of 1956, as amended, in this specific case, I beg to advise that the petition has been granted.

Decision has been filed in the office of the Commissioner of the Inspectional Services Department, 1010 Massachusetts Avenue, fifth floor, Boston, MA 02118, and is open for public inspection. Date of entry of this decision in the Inspectional Services Department was 3/15/2019.

FOR THE BOARD OF APPEAL

Kevin P. O'Connor, Jr.

Kevin P. O'Connor, Jr.
Assistant Corporation Counsel



DECISION OF THE BOARD ON THE APPEAL OF

December 11, 2018
DATE

Hudson 62 Realty, LLC

to vary the terms of the Boston Zoning Code, under Statute 1956, Chapter 665, as amended, Section 8, at premises:

155 Porter Street, Ward 01

For the terms of the Boston Zoning Code (see Acts of 1956, c. 665) in the following respect: Change in Non-Conforming Use, Extension of Non-Conforming Use, Conditional Use & Variance

Article(s): 53(53-36: Accessory conference center, Executive suites, Restaurant #38, to include take out, Retail, Coffee shop w/take out & Hotel - conditional) 53(53-8: Hotel addition is conditional in a MFR sub-district & Accessory parking on parcel located within a MFR sub-district) 53(53-52) 9(9-1) 9(9-2) 10(10-1) 53(53-37: Maximum allowed F.A.R. has been exceeded, Maximum allowed height has been exceeded & Tables subsection 53-62 Table J; insufficient open space/unit)

Construct new one story addition. Provide off street parking for 66 cars. New MEP/FA and sprinkler systems. Change occupancy from manufacturing, telephone exchange and wireless communications to 123 room hotel, restaurant #38, coffee shop #36A with takeout, telephone exchange and wireless communication. Remodel building for new uses. Combine parcels 0103927000 (22,000 s.f.), parcel 0103926000 (14,000 s.f.), and parcel 0103928000 (14,404 s.f.) to create a new parcel consisting of 50,404 s.f. *Site plan shows 50,329 s.f. actual.

In his formal appeal, the Appellant states briefly in writing the grounds of and the reasons for his appeal from the refusal of the Building Commissioner, as set forth in papers on file numbered BOA889510 and made a part of this record.

In conformity with the law, the Board mailed reasonable notice of the public hearing to the petitioner and to the owners of all property deemed by the Board to be affected thereby, as they appeared on the then most recent local tax lists, which notice of public hearing was duly advertised in a daily newspaper published in the City of Boston, namely:

THE BOSTON HERALD on Tuesday, November 20, 2018

The Board took a view of the petitioner's land, examined its location, layout and other characteristics.

The Boston Redevelopment Authority was sent notice of the appeal by the Building Department and the legal required period of time was allotted to enable the BRA to render a recommendation to the Board, as prescribed in the Code.

After hearing all the facts and evidence presented at the public hearing held on Tuesday, December 11, 2018 in accordance with notice and advertisement aforementioned, the Board finds as follows:

The Appellant appeals to be relieved of complying with the aforementioned section of the Boston Zoning Code, all as per Application for Permit# ALT878760 and September 13, 2018 plans submitted to the Board at its hearing and now on file in the Building Department.



City of Boston
Mayor Martin J. Walsh
Board of Appeal

DECISION OF THE BOARD ON THE APPEAL OF

155 Porter Street, Ward 1
BOA # 889510
Date of Hearing: 12/11/18
Permit: #ALT878760
Page: # 1

This appeal seeks permission to change occupancy from manufacturing, telephone exchange and wireless communication to a 123-room hotel, restaurant #38, coffee shop #36A with takeout, telephone exchange and wireless communication, provide off street parking for 66 cars, new MEP/FA and sprinkler systems, remodel building for new uses and combine parcels 0103927000 (22,000 s.f.), parcel 0103926000 (14,000 s.f.) , and parcel 0103928000 (14,404 s.f.) to create a new parcel consisting of 50,404 s.f. per plans on file (see Permit No. ALT878760).

The subject property is located at 175 Orleans Street a/k/a 151-155 Porter Street, in the East Boston Neighborhood of Boston, Massachusetts. The property is shown on a site plan prepared by Andersons Survey, Inc. and entitled: "Site Plan Land in Boston (East Boston) Suffolk County, Massachusetts", dated January 7, 2014 and revised January 7, 2016 (the "Plan"). The Plan is included with the project plans prepared by Sharkey Design Company and entitled "Loftel Boston", dated December 1, 2015 and filed with building Permit Application ALT878760 (the "BP Application") (the "Project Plans"). As noted on the Plan, the property contains a total lot area of 50,329 square feet, consisting of City of Boston Tax Parcels (1) 0103927000 and (2) Parcel 0103926000 (the "Main Parcels") and (3) 0103928000 (the "Secondary Parcel") (the "Site").

According to the Project Plans, the property consists of a 69,496 square foot, five (5) story concrete industrial building. The existing building was originally constructed in 1912 of cast-in-place concrete, and includes modest decorative brick façade elements that will be restored and reinforced in connection with its redevelopment. The Site is bounded to the east by Frankfort Street, a public way, to the south by the East Boston Health Center, to the west by Orleans Street, a public way, and to the north by Porter Street, a public way. The Project for which approval of Zoning Relief (as defined below) is requested is more particularly described below.

The Appellant proposes to develop the Site by the restoration/substantial renovation of the existing five (5) story building on the Site. While the original proposal also called for the construction of a new one-story addition of one (1) floor (the "Project"), the project will now consist of renovations to the original five floors. The lower five (5) floors of the Project will involve the renovation of the existing structure and the re-purposing of this existing structure from a vacant industrial building to hotel uses and restaurant and coffee shop/bakery.

According to the revised Project Plans, the top floor of the Project will contain additional hotel common areas, mechanical space, and rooms for the existing telecommunications equipment (the "Telecommunications Equipment") located on the exterior of the building, which will be placed inside and screened from public view, as shown



DECISION OF THE BOARD ON THE APPEAL OF

155 Porter Street, Ward 1
BOA # 889510
Date of Hearing: 12/11/18
Permit: #ALT878760
Page: # 2

on the Project Plans. The Telecommunications Equipment as part of the Existing Uses (as defined below) is currently being used and operated in connection with the Project and Project Uses (as defined below). The use of the Telecommunications Equipment as one of the Project Uses will continue to be a primary use of the Site.

A new restaurant serving both hotel guests and the East Boston Neighborhood will be constructed on the ground floor of the Project, which may include a café/bakery facing Orleans Street, serving the East Boston Neighborhood with much-needed amenity that will enliven this stretch of Orleans Street and make this currently inactive corner into a community destination.

The Project's one hundred twenty-three (123) hotel guestroom units generally consist of loft-style spaces. The proposed guestroom configurations make maximum use of the existing building's 12-foot floor-to-floor heights and large windows openings. This type of hotel product will provide an alternative to traditional new-construction hotel rooms that have much lower ceiling heights and less access to natural light. Large, operable windows and the restored historic façade of the existing building will contribute to the architectural quality and interest of the block.

According to the Project Plans, the height of the Project will be approximately eighty-eight (88) feet and the total floor area will be approximately 71,000 gross square feet for floors 1 through 5. As noted on the Project Plans, the existing uses of the Site are for "Manufacturing, Automatic Telephone Exchange and Wireless Communications" (the "Existing Uses") and the uses for the Project will include a "123 Room Hotel, Restaurant Use Item #38, Coffee Shop Use Item #36A, Telephone Exchange and Wireless Communications", together with parking for 66 vehicles and any uses specified in the Refusal Letter (as defined below) (the "Project Uses").

The Board notes that the Site is located within Ward 1 and the East Boston Neighborhood District, Article 53 of the Boston Zoning Code (the "Code"), which was recommended by the Boston Planning and Development Authority ("BPDA") and became effective on February 16, 1993. The Main Parcels are located within a Central Corridor CE Subdistrict ("CESD") and Special Study Overlay Area ("SSOA") on the Secondary Parcel is located within a Multi-Family Residential Subdistrict ("MFR") and Neighborhood Design Overlay District ("NDOD") (the "Zoning Subdistricts").

The Appellant re-filed its long form building permit application for the Project with the Inspectional Services Department ("ISD") on September 13, 2018. On September 19, 2018 ISD issued a refusal letter (the "Refusal Letter") indicating that relief from certain provisions



DECISION OF THE BOARD ON THE APPEAL OF

155 Porter Street, Ward 1
BOA # 889510
Date of Hearing: 12/11/18
Permit: #ALT878760
Page: # 3

of the Code was required for the Project. On or about October 12, 2018 this appeal was filed with ISD for transmittal to the Board seeking relief necessary to construct the Project.

The Appellant informed the Board that because of the size of the Project and its location, the Project was subject to Article 80, Section 80B, Large Project Review, of the Code. On August 25, 2014, in accordance with the Boston Redevelopment Authority currently known as, the Boston Planning and Development Agency (“BPDA”) policy on mitigation as outlined in Mayor Thomas M. Menino’s Executive Order Relative to the Provisions of Mitigation by Development Projects in Boston, the Appellant submitted a Letter of Intent to develop the Project. On March 4, 2015, the Appellant filed a Project Notification Form (the “PNF”) for the Proposed Project with the BPDA pursuant to Article 80B of the Code.

The PNF notice and the PNF were sent to the City of Boston’s public agencies by the BPDA pursuant to Section 80A-2 of the Code. Pursuant to Section 80B-5.3(c) of the Code, a scoping session was held on March 23, 2015 at the Jeffries Point Yacht Club. The BPDA subsequently held a BPDA sponsored public meeting on March 23, 2015 at the Jeffries Point Yacht Club. The Appellant also presented the Project to the Jeffries Point Neighborhood Association and Gove Street Neighborhood Association.

On December 10, 2015, the BPDA Board (“the BPDA Board Memo”) authorized the Director to (i) issue a Scoping Determination waiving further review under Article 80, (ii) issue a Certification of Compliance upon the successful completion of the Article 80 review process and (iii) execute and deliver a Cooperation Agreement, Boston Residents Construction Employment Plan and any and all other agreements and documents that the Director of the BPDA deems necessary and appropriate (the “BPDA Vote”).

On or about September 24, 2018, the Appellant re-presented again before the Gove Street Neighborhood Association in order to provide an update on the proposed Project and the request to renew and extend the approvals previously granted by the ZBA.

At the Hearing on December 11, 2018 before the Board, the Appellant presented to the Board and the Board viewed the renderings, drawings and Project Plans and the Appellant’s Memorandum submitted in Support of the Appeal (the “Memorandum”).

In its consideration of the Appeal, the Board has reviewed all of the documentation and information furnished to the Board in the form of Permit Application No. ALT878760, the Project Plans, and statements of support from the Mayor’s Office of Neighborhood Services (“MONS”), City Councilor Lydia Edwards, and a Referral from the BPDA to the Board



DECISION OF THE BOARD ON THE APPEAL OF

155 Porter Street, Ward 1
BOA # 889510
Date of Hearing: 12/11/18
Permit: #ALT878760
Page: # 4

dated March 17, 2016 recommending approval of the Project. There was one abutter who stood in opposition of the proposal at the hearing. (All of the above referenced documents are hereinafter to as "Documentary Materials"). In rendering its decision, the Board has reviewed, considered and incorporates by reference the Documentary Materials.

The Building Permit Application was denied for multiple violations of Articles 9, 10 and 53 of the Code. In considering the appeal, the Board grants the relief requested and required for the Project, as sought by the Appellant and as outlined in the Refusal Letter and the Appellant's Memorandum (the "Zoning Relief").

- a. Article 9-1 – Reconstruction/Extension of Nonconforming Building;
- b. Article 9-2 - Nonconforming Use Change;
- c. Article 10-1- Limitation of Parking areas;
- d. Article 53-52- Roof Structure Restrictions;
- e. Article 53-36- Use (Accessory Conference Center);
- f. Article 53-36- Use (Executive Suits);
- g. Article 53-36- Use (Restaurant #38, to include takeout);
- h. Article 53-36- Use (Retail);
- i. Article 53-36- Use (Coffee shop, to include takeout);
- j. Article 53-36- Use (Hotel);
- k. Article 53-37- Dimensional Regulations (Maximum Height has been exceeded);
- l. Article 53-37- Dimensional Regulations (Maximum FAR has been exceeded);
- m. Article 53-37- Dimensional Regulations (Insufficient open space/unit);
- n. Article 53-8- Use (Accessory parking in MFR subdistrict); and
- o. Article 53-8- Use (Hotel Addition in MFR subdistrict).

In the Appeal filed with the Board, the Appellant sought conditional use permits and variances with respect to the above referenced provisions of the Code pursuant to Articles 6, 7 and 9 of the Code and Chapter 665 of the acts of 1956 (the "Enabling Act"). In granting the Zoning Relief requested and required by the Appellant for the Project, the Board considered the conditions required for the conditional use permits and variances under Article 6, 7 and 9 of the Code and finds that such conditions are met.

Extension of Nonconforming Buildings.

The Board notes the building on the site is being lawfully used for uses not conforming to Article 53 of the Code. The Board further notes that the Appellant has determined through its predevelopment and construction estimating process that the aggregate amount expended for reconstructing, structurally changing or extending the nonconforming building does not



DECISION OF THE BOARD ON THE APPEAL OF

155 Porter Street, Ward 1
BOA # 889510
Date of Hearing: 12/11/18
Permit: #ALT878760
Page: # 5

exceed fifty percent (50%) of the physical value of the building based on a reproduction cost less physical deterioration method of valuation.

In accordance with Section 9-1 of the Code, the Board finds that the existing building on the Site is being lawfully used for a use not conforming to this Code and that such building or structure may be reconstructed, structurally changed or extended; that in accordance with Article 6 of the Code the Board hereby grants permission for such reconstructions, structural change or extension; that the building or structure as reconstructed, structurally changed or extended does not exceed more than twenty-five (25%) percent either in volume or in area the building structure existing on the effective date of the Code, as amended, and that the aggregate amount expended for reconstructing, structurally changing or extending the nonconforming building after the effective date of the Code, as amended, does not exceed fifty percent (50%) of the physical value of the building or structure on the effective date of the Code, as amended, as determined by the Board from its reproduction cost less physical deterioration.

Change in Nonconforming Use.

In accordance with Section 9-2 of the Code, the Board finds that on the effective date of the Code, as amended, the Site was being lawfully used for the Existing Uses and not conforming to this Code, as amended, and that the Site may be used for the Project Uses. The Board further finds that the Project Uses comply with the requirements of Article 6 of the Code and that upon the use of Site for the Project Uses, the right to use such structure or land for the Existing Uses use shall terminate.

Limitation of Parking Areas.

The Appellant informed the Board that the Project does not conform with the limitations of area as cited in the Refusal Letter. Article 10, Section 1 of the Code establishes certain limitations for parking areas. The Project requires zoning relief from Article 10, Section 1 because the Project fails to comply with the requirements of Article 10, Section 1, including but not limited to the location of handicap parking spaces, fire land and other matters as shown on the Project Plans.

Roof Structure Restrictions.

The Appellant informed the Board that the Project does not conform with the roof structure restrictions as cited in the Refusal Letter. The Board finds that the Project complies with the requirements of Article 53, Section 52 of the Code as shown on the Project Plans in



DECISION OF THE BOARD ON THE APPEAL OF

155 Porter Street, Ward 1
BOA # 889510
Date of Hearing: 12/11/18
Permit: #ALT878760
Page: # 6

accordance with Article 6 of the Code because roof structure does not have the potential of damaging the uniformity of height or architectural character of the immediate vicinity.

Dimensional Requirements.

The Appellant informed the Board that the Project does not conform with the dimensional limitations cited in the Refusal Letter. As noted in the Refusal Letter, the proposed building does not comply with the requirements of the Code for (1) Floor Area Ratio, (2) Building Height, and (3) Open space, if applicable under Article 53. The project will have a building containing approximately 71,000 gross square feet and a Floor Area Ratio of 1.42. The height of the Project will be eighty-eight (88) feet and six (6) stories. The amount of useable open space is as shown on the Project Plans. The actual dimensions of the Project are more specifically shown on the Project Plans which shall control and govern. Therefore, the Appellant requested and the Board grants by variance in accordance with Article 7 of the Code relief from these provisions of the Code for the reasons as set forth below.

Uses.

As noted by the Appellant, the Zoning Subdistricts that the Project is located in restrict certain uses. The Appellant has requested and the Board grants by conditional use permits and variances in accordance with Article 6 and Article 7 of the Code relief from the provisions of the Code for the Project Uses for the reasons set forth herein.

Based upon the Project Plans, BPDA Vote and community process, the Board find that the Project Uses at the site are harmonious and beneficial to residential and commercial uses within the immediate vicinity of the Site. The significance of developing this Site for the Project Uses has been acknowledged by BPDA in its review of the PNF. The Appellant, BPDA and the community further acknowledged that the Site is largely undeveloped with a deteriorated industrial building that has long been an eye sore to the East Boston community and that the Project and Project Uses would greatly benefit the East Boston community.

The Board also finds that the Project Uses and the Zoning Relief required for the Project is not only appropriate, but necessary for the provision of economic development in the East Boston Neighborhood. In accordance with Section 53-35 of the Code, the purpose of establishing a CESD is to promote the siting and design of any new development in a manner that is sensitive to the adjacent residential and open space. The Project as shown on the Project Plans is sensitive to the adjacent residential and open space because of the existing setbacks, landscaping, screening and buffering. The Appellant informed the Board and the



DECISION OF THE BOARD ON THE APPEAL OF

155 Porter Street, Ward 1
BOA # 889510
Date of Hearing: 12/11/18
Permit: #ALT878760
Page: # 7

Board notes that as shown on the Project Plans, the Site is unmaintained and contains a deteriorated industrial building. The Site is unique in the neighborhood and is unlike other areas of the neighborhood which have been developed.

The Board finds that the continued under use of this underdeveloped lot and building would continue to adversely impact the neighborhood and its underutilization is a special condition and circumstance which affects only this Site and not the remaining areas of the neighborhood, which are developed. Therefore, the Board finds that the necessity of developing the Site for the Project Uses is in accordance with the provisions of the Code and promotes the health, safety, convenience, morals and welfare of the inhabitants of the City of Boston and the East Boston Neighborhood. The Board finds that the continuation of the present circumstances and conditions of the Site without development are detrimental to the neighborhood and would deprive the Appellant of the reasonable use of the land and the potential structures.

Additionally, the Board notes that the limitation of the Site for its current use would not generate economic development in the East Boston Neighborhood. This would be a demonstrable and substantial hardship imposed not only on the Appellant but also the East Boston Neighborhood as a whole. Therefore, the Board finds that the granting of the conditional use permits and variances are necessary for the reasonable use of the land and that these are the minimum variances necessary for the Project and Project Uses.

The Appellant submitted in addition to the reasons outlined in its Appeal, the following information with respect to the uniqueness of the Site and Project, which indicates that there are special circumstances and conditions, fully described herein, applying to the Site and Project for which the Zoning Relief is sought, and which circumstances and conditions are peculiar to the Site and Project, but not the neighborhood, and that said circumstances or conditions are such that the application of the provisions of this Code without the grant of relief by the Board will deprive the Appellant of the reasonable use of the Site and Project.

The Project contains substantial and significant capital improvements to the Site and allows for the retention of the existing building as an element of the East Boston Neighborhood. The Project will cost approximately Twenty Million (\$20,000,000.00) Dollars to complete and provide approximately one hundred fifty (150) construction jobs during the course of the Project. Approximately, fifteen (15) full time jobs will be created upon the completion of the Project. The Project, as proposed to the Board, will provide a design which is in harmony with the East Boston Neighborhood and with general purpose and intent of the Code which is set forth in Article 1, Section 1-2 of the Code, subject to BPDA Design Review as noted below. Specifically, the granting of relief by the Board for



DECISION OF THE BOARD ON THE APPEAL OF

155 Porter Street, Ward 1
BOA # 889510
Date of Hearing: 12/11/18
Permit: #ALT878760
Page: # 8

the Project will encourage the general purpose and intent of the Code, including but not limited to: ensuring the most appropriate use of land, conserving the value of the land and the building, lessening congestion in the streets, and providing adequate light and air for existing buildings.

The approval by the BPDA under Article 80B of the Code, together with positive recommendations of approval of the necessary Zoning Relief is supportive of the Appellant's request for the reasonable use of the land or structure with such variances and approvals from the Board and which are the minimum variances that will accomplish this purpose. Furthermore, based upon the extensive community review, the BPDA review and approval of the Project under Article 80B of the Code and the re-use of the existing building within the Project, the Board finds that such elements support the following findings: the specific site is an appropriate location for such use; that the use will not adversely affect the neighborhood; that there will be no serious hazard to vehicles or pedestrians from the use; that no nuisance will be created by the use; and that adequate and appropriate facilities will be provided for the proper operation of the use. BPDA Design Review will help ensure a good and sufficient design and other controls over the Project.

The Board finds that based on the BPDA Article 80B Large Project Review approval and widespread community support for the Project, the specific site is an appropriate location for the Project Uses. The Board finds that the Project Uses will not adversely affect the neighborhood but rather better activate and enliven it as noted by the BPDA and as evidenced by the broad-based community support for the Project. The existing building at the Site is an eyesore to the community and has long been abandoned. There will be no serious hazard to vehicles or pedestrians from the use as evidenced by the BPDA Article 80B Large Project Review approval which contained traffic and transportation components and mitigation as requested and recommended by the Boston Transportation Department. In addition, the streetscape improvements to Orleans Street, Frankfort Street and Porter Street will help improve vehicle and pedestrian traffic flow. As noted by the BPDA and as evidenced by the broad-based community support of the Project, the Board finds no nuisance will be created. Instead, public safety will actually be improved through the activation of the Site which will help deter crime and other activities. Finally, as evidenced by the Project Plan, the Board finds that approved adequate and appropriate facilities will be provided for the proper operation of the use.

The Board also finds that the variances for the Project will be in harmony with the general purpose and intent of the Code and will not be injurious to the neighborhood or otherwise detrimental to the public welfare since the Project has gone through a neighborhood review process as well as BPDA Large Project Review under Article 80 of the



DECISION OF THE BOARD ON THE APPEAL OF

155 Porter Street, Ward 1
BOA # 889510
Date of Hearing: 12/11/18
Permit: #ALT878760
Page: # 9

Code.

With respect to the requested grant of relief through a variance, the Board finds that all of the following conditions are met:

- (a) That there are special circumstances or conditions, fully described in the findings, applying to the land or structure for which the variance is sought (such as, but not limited to, the exceptional narrowness, shallowness or shape of the lot, or exceptional topographical conditions thereof), which circumstances or conditions are peculiar to such land or structure but not the neighborhood, and that said circumstances or conditions are such that the application of the provisions of this Code would deprive the appellant of the reasonable use of such land or structure; and
- (b) That for reasons of practical difficulty and demonstrable and substantial hardship fully described in the findings, the granting of the variance is necessary for the reasonable use of the land or structure and that the variance as granted by the Board is the minimum variance that will accomplish this purpose; and
- (c) That the granting of the variance will be in harmony with the general purpose and intent of this Code and will not be injurious to the neighborhood or otherwise detrimental to the public welfare.
- (d) That, the variance is not for a Development Impact Project, as defined in Section 2602, 26A-1 or 26B-2, and the Appellant is not required to comply with the Development Impact Project requirements.

In determining its findings, the Board of Appeal has taken into account: (1) the number of persons residing or working upon such land or in such structure; (2) the character and use of adjoining lots and those in the neighborhood; and (3) traffic conditions in the neighborhood.

The Board also makes the following findings:

- (a) The specific site is appropriate located for such use;
- (b) The use will not adversely affect the neighborhood;
- (c) There will be no serious hazard to vehicles or pedestrians from the use;
- (d) No nuisance will be created by the use; and
- (e) Adequate and appropriate facilities will be provided for the proper operation of the



City of Boston
Mayor Martin J. Walsh
Board of Appeal

DECISION OF THE BOARD ON THE APPEAL OF

155 Porter Street, Ward 1
BOA # 889510
Date of Hearing: 12/11/18
Permit: #ALT878760
Page: # 10

use.

Therefore, based upon the foregoing, the Board grants the necessary Zoning Relief to enable the Appellant to utilize the Site for the Project and Project Uses in accordance with the Project Plans. In order that the intent and purpose of the Code be enforced, realized and applicable to the Appellant, and that the Appellant be able to make reasonable use of the Site in such a manner that is not contrary to the public good, the Board hereby grants the relief sought by the Appellant. The Board makes these findings based upon the following: its review of the Code, including but not limited to the language of Article 1, Section 1-2 of the Code, the testimony, Project Plans, renderings, and Documentary Materials presented at the Hearing and the actions and decisions of this Board in reviewing and approving other requests for relief.

The Board is of the opinion that all conditions required for the granting of the conditional use permits and variances under Article 6, Article 7 and Article 9 of the Code have been met and that the varying of the terms of the Code as outlined above will not be in conflict with the intent and spirit of the Code.



City of Boston
 Mayor Martin J. Walsh
 Board of Appeal

155 Porter Street, Ward 1
 BOA # 889510
 Date of Hearing: 12/11/18
 Permit: #ALT878760
 Page: # 11

DECISION OF THE BOARD ON THE APPEAL OF

Therefore, acting under its discretionary power, the Board (the members and substitute member(s) sitting on this appeal) unanimously voted to grant the conditional use permits and variances as described above, annuls the refusal of the Building Commissioner and orders him to grant a permit in accordance with this decision, with the following proviso which, if not complied with, shall render this decision null and void.

APPROVED AS TO FORM:

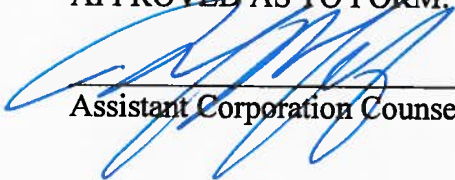
 Assistant Corporation Counsel

PROVISO:

1. Subject to continued design review by BPDA.

Signed, March 12, 2019

 Christine Araujo - Chairperson

 Mark Fortune - Secretary

 Anthony Pisani

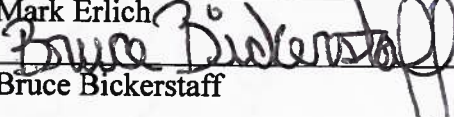
 Bruce Bickerstaff

 Marie St. Fleur

 Craig Galvin

LAW OFFICES OF
RICHARD C. LYNDS

245 SUMNER STREET, SUITE 110
EAST BOSTON, MASSACHUSETTS 02128
TEL: 617.207.1190 FAX: 617.207.1195

email: rclyndsesq@lorcl.com

December 11, 2020

VIA EMAIL

Christine Araujo, Chairwoman
Board of Appeal of the City of Boston
1010 Massachusetts Avenue, 4th Floor
Boston, MA 02118

RE: Request for Extension of Granted Variance
155 Porter Street, BOA #889510, Permit # ALT878760

Dear Chairwoman Araujo:

This office represents the legal interests of the owner/developer of the real property located at 155 Porter Street, Boston, MA (the "Premises") with respect to the above referenced matter. Allow this letter to serve as a request for a one (1) year extension of the zoning relief granted in the above referenced matter, which is set to expire on March 15, 2021.

A Variance for the Premises was granted by the Board of Appeal ("BOA") at a public hearing held on December 11, 2018, with the decision entered in the Inspectional Services Department on March 15, 2019. The decision granted permission to change occupancy from manufacturing, telephone exchange and wireless communication to a 123-room hotel, restaurant #38, coffee shop #36A with takeout, telephone exchange and wireless communication, provide off street parking for 66 cars, new MEP/FA and sprinkler systems, remodel building for new uses and combine parcels.

The owner/developer is in the process of securing their building permit.

As such, request is hereby made that the Board of Appeal grant an extension of the Variance for a period of one (1) year, so as to extend the expiration date from March 15, 2021 to March 15, 2022, which will allow ISD to complete the review and the permit to issue.

Thank you for your consideration of this matter.

Very truly yours,



Richard C. Lynds, Esq.

RCL/las

cc: Kevin O'Conner., Esq. BOA

Signed January 12, 2021
Christine Araujo-Chair
/s/Christine Araujo-Voted In Favor
Mark Erlich
/s/Mark Erlich-Voted In Favor
Mark Fortune-Secretary
/s/ Mark Fortune-Voted In Favor
Joseph Rugierro
/s/Joseph Rugierro-Voted In Favor
Kosta Ligirs
/s/ Kosta Ligirs-Voted In Favor
Edward Deveau(Alternate)
/s/Edward Deveau-Voted In Favor
Tyrone Kindell, Jr
/s/ Tyrone Kindell, Jr-Voted In Favor

At it's regularly scheduled hearing date of January 12, 2021, the Board of Appeal memers sitting for this appeal voted to grant a one year extension ending March 15, 2022



November 25, 2020

Ashok Patel
Jamsan Hotel Management
83 Hartwell Ave
Lexington, MA, US, 02421

RE: Contract Document Approval – 175 Orleans Street, East Boston, MA

Dear Mr. Patel:

We are pleased to grant Contract Document Approval for the new hotel at 175 Orleans Street, East Boston. Approval for this building is subject to the conditions contained in this letter. This Approval is based on the plans entitled, “Conversion to Boston Hotel”, August 29, 2018, Revision November 23, 2020, by Russell & Dawson Architecture and Engineering . You will find attached a list of record drawings (Attachment A). It is now that we can conclude your review and present you with Full Contract Document Approval for the overall project.

The approval also contains the following provisos:

1. All changes to the approved exterior and/or site plans shall be submitted to the Boston Planning and Development Agency (“BPDA”) for review and approval.
2. Samples of all exterior materials and finishes shall be reviewed and approved by the BPDA prior to ordering.
3. A mock-up panel of a sufficient size (4’x8’ for example) demonstrating all exterior materials and finishes as well as construction details of the Project shall be erected on site for review and approval by the BPDA. A drawing of the mock-up panel showing what will be built shall be submitted to the BPDA for review and approval prior to construction of the panel.
4. All penthouse/rooftop mechanical equipment, utility meters, electrical transformers, and/or HVAC equipment placed on the site and/or attached to the building shall be adequately screened from public view. Equipment and screening shall be indicated on appropriate roof plan and elevation drawings with all materials (and lighting if proposed) clearly indicated. Any changes from the final BPDA-approved Contract Documents to the location of penthouse equipment or other publicly visible utilities (location, dimension, detail, or materials) must be submitted to the BPDA for review and approval prior to execution. All screening must be completed *prior to issuance of occupancy permit by ISD* unless prior approval is granted by the BPDA for a delay in completing the screening. Any environmental issues that arise from the rooftop mechanical unit shall be reported to the BPDA for review.



5. All mechanical vents shall be through the roof or rear wall and shall not be visible from a public way whenever possible. Vents located on elevations that do not directly face a public way should be composed on the facade so as to minimize their appearance. The final design of the vent caps shall be submitted to the BPDA for review and approval.
6. All building and site signage (including tenant signage) shall be reviewed and approved separately by the BPDA after a submittal of a comprehensive sign.
7. All building improvements shall be completed *prior to issuance of occupancy permit by ISD* unless prior approval is granted by the BPDA.
8. All site improvements including landscaping must be completed *prior to issuance of occupancy permit by ISD* unless prior approval is granted by the BPDA for a delay in completing the site improvements.
9. The canopy design as shown for the front entrance, and as detailed on A-425 shall be redesigned to be more stylistically in tune with the historic industrial building that is being restored. Architect will study canopy roofs & loading areas that were more typical of this building type and submit a new design to BPDA for review and approval before the mock-up stage of the process.
10. All new windows to utilize simulated divided light grilles in their design

It is understood that the Project will now enter the Inspection stage of the BPDA Development Review Process. We require the timely submission of any changes to the approved documents, and material samples, for further review and approval. This includes significant changes or modifications (including detail development) to the approved plans, and other information, such as building materials (windows and doors, new masonry, mortar) choices, affecting the exterior work proposed for the building. See Attachment B. Please feel free to call me with any questions or comments regarding this approval.

Sincerely,

Matthew Martin
Urban Designer

Cc: Raul Duverge, BPDA
Utkarsh Patil, Russell Dawson
Richard Lynds, LORCL
Sean Nehill, BPDA



ATTACHMENT A

16155.01 – 175 ORLEANS STREET, BOSTON

OF WORK				
SCOPE				
CONVERSION OF AN EXISTING 5 STORY INDUSTRIAL BUILDING TO 5 STORY HOTEL.				
LIST OF SHEETS				
SHEET NO.	SHEET NAME	DATE	REV. #	REV. DATE
	SITE PLAN	02/15/2017		04/06/2017
PL-100	PARCEL PLAN	12/08/2017	7	11/26/2019
C-100	SITE PREPARATION PLAN	12/08/2017	7	11/26/2019
C-101	LAYOUT AND MATERIALS PLAN	12/08/2017	9	11/20/2020
C-102	GRADING AND UTILITY PLAN	12/08/2017	8	01/02/2020
C-103	TRUCK TURNING MOVEMENTS	12/08/2017	8	01/02/2020
C-201	PROFILES & DETAILS	12/08/2017	7	11/26/2019
C-202	DETAILS	12/08/2017	7	11/26/2019
C-203	DETAILS	12/08/2017	7	11/26/2019
C-204	DETAILS	12/08/2017	7	11/26/2019
L-101	LANDSCAPE PLAN, NOTES, DETAILS AND SCHEDULE	12/08/2017	4	01/02/2020
L-201	GREEN ROOF LANDSCAPE DETAILS	01/02/2020		
G-000	COVER SHEET	08/29/2018	6	11/23/2020
G-001	LIST OF SHEETS	08/29/2018		
G-002	CODE ANALYSIS, SYMBOL LEGENDS & GENERAL NOTES	08/29/2018		
G-003	RATING & EXITING DIAGRAMS	08/29/2018		
G-004	GENERAL NOTES	08/29/2018		
AD-101	DEMOLITION BASEMENT & FIRST FLOOR PLAN	08/29/2018		
AD-102	DEMOLITION SECOND FLOOR PLAN	08/29/2018		



AD-103	DEMOLITION THIRD FLOOR PLAN	08/29/2018		
AD-104	DEMOLITION FOURTH FLOOR PLAN	08/29/2018		
AD-105	DEMOLITION FIFTH FLOOR PLAN	08/29/2018		
AD-106	DEMOLITION ROOF PLAN	08/29/2018		
AD-201	DEMOLITION ELEVATION	08/29/2018	3	11/27/2019
AD-202	DEMOLITION ELEVATION	08/29/2018	2	LLLLL
A-101	BASEMENT & FIRST FLOOR PLAN	08/29/2018	4	01-03-2020
A-102	SECOND FLOOR PLAN	08/29/2018		
A-103	THIRD FLOOR PLAN	08/29/2018		
A-104	FOURTH FLOOR	08/29/2018		
A-105	FIFTH FLOOR PLAN	08/29/2018		
A-106	SIXTH FLOOR PLAN	08/29/2018		
A-107	ROOF PLAN	08/29/2018	3	11/27/2019
SCOPE OF WORK				
CONVERSION OF AN EXISTING 5 STORY INDUSTRIAL BUILDING TO 5 STORY HOTEL.				
LIST OF SHEETS				
SHEET NO.	SHEET NAME	DATE	REV. #	REV. DATE
A-108	ROOF EPDM DETAILS	08/29/2018		
A-109	ROOF EPDM SPECIFICATIONS	08/29/2018		
A-201	BUILDING ELEVATION - REAR	08/29/2018	5	01/13/2020
A-202	BUILDING ELEVATION - FRONT	08/29/2018	4	01-03-2020
A-203	BUILDING ELEVATIONS - LEFT & RIGHT	08/29/2018	6	11/23/2020
A-300	BUILDING SECTIONS	08/29/2018	3	11/27/2019
A-301	BUILDING SECTIONS	08/29/2018	3	11/27/2019
A-302	BUILDING SECTIONS	08/29/2018	4	01-03-2020
A-303	BUILDING SECTIONS	08/29/2018	3	11/27/2019
A-304	WALL SECTION DETAILS	08/29/2018		
A-305	WALL SECTION DETAILS	08/29/2018	4	01-03-2020
A-306	WALL SECTION DETAILS	08/29/2018		
A-400	TYPICAL MOUNTING HEIGHTS & GUESTROOM BATHROOM SCHEDULE	08/29/2018		
A-400a	FF & E SCHEDULE	08/29/2018		
A-401	ENLARGED PLANS & ELEVATIONS - KING A	08/29/2018	1	08/31/2018
A-402	ENLARGED PLANS & ELEVATIONS - KING SUITE A	08/29/2018	1	08/31/2018



A-403	ENLARGED PLANS & ELEVATIONS - DOUBLE QUEEN A	08/29/2018	1	08/31/2018
A-404	ENLARGED PLANS & ELEVATIONS - DOUBLE QUEEN B	08/29/2018	1	08/31/2018
A-405	ENLARGED PLANS & ELEVATIONS - DOUBLE QUEEN C	08/29/2018	1	08/31/2018
A-406	ENLARGED PLANS & ELEVATIONS - DOUBLE QUEEN D	08/29/2018	1	08/31/2018
A-407	ENLARGED PLANS & ELEVATIONS - DOUBLE QUEEN CORNER	08/29/2018	1	08/31/2018
A-408	ENLARGED PLANS & ELEVATIONS - ACC. KING SUITE ROLL IN SHOWER	08/29/2018	1	08/31/2018
A-409	ENLARGED PLANS & ELEVATIONS - ACCESSIBLE KING ROLL IN SHOWER	08/29/2018	1	08/31/2018
A-410	ENLARGED PLANS & ELEVATIONS - ACCESSIBLE DOUBLE QUEEN	08/29/2018	1	08/31/2018
A-411	ENLARGED BATHROOM PLANS & ELEVATIONS - KING A, DOUBLE QUEEN A & DOUBLE QUEEN D	08/29/2018	3	11/27/2019
A-412	ENLARGED BATHROOM PLANS & ELEVATIONS - KING SUITE A, B & DOUBLE QUEEN B	08/29/2018	3	11/27/2019
A-413	ENLARGED BATHROOM PLANS & ELEVATIONS - DQ CORNER & DOUBLE QUEEN C	08/29/2018	3	11/27/2019
SCOPE OF WORK				
CONVERSION OF AN EXISTING 5 STORY INDUSTRIAL BUILDING TO 5 STORY HOTEL.				
LIST OF SHEETS				
SHEET NO.	SHEET NAME	DATE	REV. #	REV. DATE
A-414	ENLARGED BATHROOM PLANS & ELEVATIONS - ACCESSIBLE KING ROLL IN SHOWER	08/29/2018	3	11/27/2019
A-415	ACC.KING SUITE & ADA KING WITH ROLL IN SHOWER	08/29/2018	3	11/27/2019
A-416	BATHROOM TYPICAL DETAILS	08/29/2018	3	11/27/2019
A-417	ENLARGED COMMON AREA PLAN	08/29/2018		
A-418	ENLARGED FRONT DESK PLAN & ELEVATIONS	08/29/2018		
A-419	ENLARGED PUBLIC RESTROOM PLAN & ELEVATIONS	08/29/2018	3	11/27/2019
A-420	ENLARGED FITNESS ROOM PLAN AND ELEVATIONS	08/29/2018	3	11/27/2019



A-421	ENLARGED MEETING ROOM PLAN AND ELEVATIONS	08/29/2018		
A-422	ENLARGED BACK OF HOUSE OFFICE PLAN AND ELEVATIONS	08/29/2018		
A-423	ENLARGED EMPLOYEE BREAKROOM PLAN & ELEVATIONS	08/29/2018	3	11/27/2019
A-424	ENLARGED ICE MACHINE ROOM, GUEST LAUNDRY & LAUNDRY CHUTE PLANS, ELEVATIONS & SECTION	08/29/2018		
A-425	PORTE COCHERE PLAN & DETAILS	08/29/2018		
A-426	ENTRY CANOPY PLAN & DETAILS	08/29/2018		
A-427	ENLARGED PENT PLAN, ELEVATION AND CHIMNEY DETAILS.	08/29/2018		
A-428	HISTORIC CORNER ENTRANCE ENLARGED DETAILS	08/29/2018		
A-429	MILLWORK- ELEVATIONS, DETAILS & SECTIONS	08/29/2018		
A-430	BATHROOM ENLARGED DETAILS	08/29/2018		
A-431	MILLWORK DETAILS	08/29/2018		
A-432	MILLWORK - ELEVATIONS, DETAILS & SECTIONS	08/29/2018		
A-433	CASEWORK DETAILS	08/29/2018		
A-501	WALL TYPES	08/29/2018		
A-502	WALL TYPES	08/29/2018		
A-503	COLUMN DETAIL	08/29/2018		
A-504	FIRE RESISTING ASSEMBLIES	08/29/2018		
A-505	WALL PENETRATION DETAILS	08/29/2018		
A-506	FIRE RESISTING ASSEMBLIES	08/29/2018		
A-601	DOOR SCHEDULE	08/29/2018	3	11/27/2019
A-601a	DOOR HARDWARE SPECIFICATIONS	08/29/2018	3	11/27/2019
A-601b	DOOR HARDWARE SPECIFICATIONS	08/29/2018		
SCOPE OF WORK				
CONVERSION OF AN EXISTING 5 STORY INDUSTRIAL BUILDING TO 5 STORY HOTEL.				
LIST OF SHEETS				
SHEET NO.	SHEET NAME	DATE	REV. #	REV. DATE
A-602	DOOR DETAILS	08/29/2018	6	11/23/2020
A-603	DOOR DETAILS AND FLOOR TRANSITIONS	08/29/2018		
A-604	ENLARGED DOOR ELEVATIONS & DETAILS, WINDOW DETAILS	08/29/2018		



A-605	WINDOW ELEVATIONS, KEY NOTES & GENERAL NOTES	08/29/2018	5	01/13/2020
A-606	WINDOW AND STORE FRONT ELEVATION	08/29/2018	4	01-03-2020
A-607	WINDOW AND STORE FRONT ELEVATION	08/29/2018	3	11/27/2019
A-608	WINDOW DETAILS - 1	08/29/2018	3	11/27/2019
A-609	WINDOW DETAILS	08/29/2018		
A-610	ROOM FINISH SCHEDULES	08/29/2018	3	11/27/2019
A-611	CEE-LOCK PANEL	08/29/2018		
A-701	STAIR-1 PLAN, SECTION AND DETAILS	08/29/2018	3	11/27/2019
A-702	STAIR-2 PLAN, SECTION AND DETAILS	08/29/2018	3	11/27/2019
A-703	STAIR DETAILS	08/29/2018		
A-704	ELEVATOR PLAN, SECTIONS AND DETAILS	08/29/2018	3	11/27/2019
A-706	LINEN CHUTE PLAN, SECTIONS AND DETAILS	08/29/2018		
A-707	ENLARGED ELEVATOR DOOR DETAIL	08/29/2018		
A-801	FIRST FLOOR REFLECTED CEILING PLAN	08/29/2018	1	08/31/2018
A-802	TYPICAL REFLECTED CEILING PLAN (2ND, 3RD, 4TH)	08/29/2018	1	08/31/2018
A-803	FIFTH FLOOR REFLECTED CEILING PLAN	08/29/2018	1	08/31/2018
A-804	ROOF PLAN REFLECTED CEILING PLAN	08/29/2018		
A-805	REFLECTED CEILING PLAN COMMON AREAS	08/29/2018		
A-806	CEILING DETAILS & WINDOW DETAILS	08/29/2018		
S-001	ABBREVIATIONS AND SYMBOLS LEGEND	08/29/2018		
S-002	GENERAL NOTES & SCHEDULES	08/29/2018		
S-003	STRUCTURAL NOTES	08/29/2018	1	7/29/19
S-100	COLUMN GRID AND FOUNDATION LAYOUT PLAN	08/29/2018		
S-101	FOUNDATION PLAN	08/29/2018	4	01/14/20
S-201	FOUNDATION SECTIONS & DETAILS	08/29/2018		
S-202	FOUNDATION DETAILS	08/29/2018	2	11/26/19
S-203	FOUNDATION DETAILS	08/29/2018	3	01-03-2020
S-204	FOUNDATION DETAILS	08/29/2018		
S-301	PORTE COCHERE & CANOPY FRAMING PLANS AND DETAILS	08/29/2018	2	11/26/19
S-302	SECOND FLOOR FRAMING PLAN	08/29/2018		
SCOPE OF WORK				
CONVERSION OF AN EXISTING 5 STORY INDUSTRIAL BUILDING TO 5 STORY HOTEL.				
LIST OF SHEETS				



SHEET NO.	SHEET NAME	DATE	REV. #	REV. DATE
S-303	THIRD FLOOR FRAMING PLAN	08/29/2018		
S-304	FOURTH FLOOR PLAN	08/29/2018		
S-305	FIFTH FLOOR PLAN	08/29/2018		
S-306	ROOF FRAMING PLAN	08/29/2018		
S-307	DUNNAGE FRAMING PLANS	08/29/2018		
S-400	FRAMING DETAILS	08/29/2018		
S-401	FRAMING DETAILS	08/29/2018		
S-402	FRAMING DETAILS	08/29/2018		
S-403	FRAMING DETAILS	08/29/2018		
S-404	FRAMING DETAILS	08/29/2018		
S-405	FRAMING DETAILS	08/29/2018		
S-406	FRAMING DETAILS	08/29/2018		
S-407	FRAMING DETAILS	08/29/2018		
S-501	LATERAL FRAME ELEVATIONS	08/29/2018		
S-502	LATERAL FRAME ELEVATIONS AND DETAILS	08/29/2018	3	01-03-2020
S-601	COLUMN SCHEDULES	08/29/2018		
P-001	PLUMBING GENERAL NOTES, LEGENDS AND SCHEDULE	08/29/2018	1	11/26/2019
P-002	PLUMBING SPECIFICATIONS	08/29/2018		
P-003	PLUMBING SCHEDULES	08/29/2018	1	11/26/2019
P-100	FIRST FLOOR PLAN - PLUMBING	08/29/2018	2	01-03-2020
P-101	BASEMENT & FIRST FLOOR CEILING PLAN - PLUMBING	08/29/2018	2	01-03-2020
P-102	SECOND FLOOR PLAN - PLUMBING	08/29/2018	1	11/26/2019
P-103	THIRD FLOOR PLAN - PLUMBING	08/29/2018	1	11/26/2019
P-104	FOURTH FLOOR PLAN - PLUMBING	08/29/2018	1	11/26/2019
P-105	FIFTH FLOOR PLAN - PLUMBING	08/29/2018	1	11/26/2019
P-106	FIFTH FLOOR CEILING PLAN - PLUMBING	08/29/2018	1	11/26/2019
P-107	SIXTH FLOOR PLAN - PLUMBING	08/29/2018	1	11/26/2019
P-108	ROOF PLAN - PLUMBING	08/29/2018		
P-201	ENLARGED GUESTROOM PLUMBING PLAN HW & CW	08/29/2018	1	11/26/2019
P-201a	ENLARGED PUBLIC RESTROOM	08/29/2018	1	11/26/2019
P-202	ENLARGED GUESTROOM PLUMBING PLAN SAN, WASTE & VENT	08/29/2018	1	11/26/2019



P-203	HOT WATER HEATER PIPING SCHEMATIC AND SCHEDULE	08/29/2018	1	11/26/2019
P-301	PLUMBING DETAILS	08/29/2018	1	11/26/2019
SCOPE OF WORK				
CONVERSION OF AN EXISTING 5 STORY INDUSTRIAL BUILDING TO 5 STORY HOTEL.				
LIST OF SHEETS				
SHEET NO.	SHEET NAME	DATE	REV. #	REV. DATE
P-302	PLUMBING DETAILS	08/29/2018	1	11/26/2019
P-303	PLUMBING DETAILS	08/29/2018	1	11/26/2019
P-304	PLUMBING DETAILS	08/29/2018		
P-305	PLUMBING DETAILS	08/29/2018		
P-401	PLUMBING ISOMETRIC DIAGRAM. HOT, COLD WATER	08/29/2018		
P-402	PLUMBING ISOMETRIC DIAGRAM. HOT, COLD WATER	08/29/2018	1	11/26/2019
P-403	PLUMBING ISOMETRIC DIAGRAM. WASTE AND VENT	08/29/2018	1	11/26/2019
M-001	MECHANICAL PERFORMANCE SPECIFICATIONS	08/29/2018		
M-002	MECHANICAL SCHEDULES	08/29/2018		
M-003	MECHANICAL SPECIFICATIONS AND SCHEDULES	08/29/2018	1	11/26/2019
M-004	HVAC SCHEDULE	08/29/2018	1	11/26/2019
M-005	MECHANICAL DIAGRAM	08/29/2018		
M-006	MECHANICAL DIAGRAM	08/29/2018		
M-007	MECHANICAL DIAGRAM	08/29/2018		
M-008	MECHANICAL DIAGRAM	08/29/2018		
M-009	MECHANICAL DIAGRAM	08/29/2018		
M-101	BASEMENT & FIRST FLOOR PLAN- MECHANICAL	08/29/2018	1	11/26/2019
M-102	SECOND FLOOR PLAN- MECHANICAL	08/29/2018	1	11/26/2019
M-103	THIRD FLOOR PLAN - MECHANICAL	08/29/2018	1	11/26/2019
M-104	FOURTH FLOOR PLAN - MECHANICAL	08/29/2018	1	11/26/2019
M-105	FIFTH FLOOR PLAN - MECHANICAL	08/29/2018	1	11/26/2019
M-106	SIXTH FLOOR PLAN - MECHANICAL	08/29/2018	1	11/26/2019
M-107	ROOF FLOOR PLAN - MECHANICAL	08/29/2018	1	11/26/2019
M-300	MECHANICAL DETAILS	08/29/2018		
M-301	MECHANICAL DETAILS	08/29/2018		
M-302	MECHANICAL DETAILS	08/29/2018		



M-303	HVAC RISER SECTION	08/29/2018	1	11/26/2019
E-001	LEGENDS	08/29/2018		
E-002	ELECTRICAL PERFORMANCE SPECIFICATIONS	08/29/2018		
E-003	ELECTRICAL SPECIFICATIONS	08/29/2018		
E-004	ELECTRICAL SPECIFICATIONS	08/29/2018		
E-005	LIGHT FIXTURE SCHEDULE	08/29/2018	1	11/26/2019
E-006	ELECTRICAL EQUIPMENT SCHEDULES	08/29/2018	1	01-03-2020
SCOPE OF WORK				
CONVERSION OF AN EXISTING 5 STORY INDUSTRIAL BUILDING TO 5 STORY HOTEL.				
LIST OF SHEETS				
SHEET NO.	SHEET NAME	DATE	REV. #	REV. DATE
EL-100	LIGHTING PLAN DRAWING NOTES	08/29/2018		
EL-101	BASEMENT & FIRST FLOOR- LIGHTING PLAN	08/29/2018	1	11/26/2019
EL-102	SECOND FLOOR LIGHTING PLAN	08/29/2018		
EL-103	THIRD FLOOR LIGHTING PLAN	08/29/2018		
EL-104	FOURTH FLOOR LIGHTING PLAN	08/29/2018		
EL-105	FIFTH FLOOR LIGHTING PLAN	08/29/2018		
EL-106	ROOF LIGHTING PLAN	08/29/2018		
EP-100	POWER PLAN DRAWING NOTES	08/29/2018		
EP-101	BASEMENT & FIRST FLOOR POWER PLAN	08/29/2018	2	01-03-2020
EP-102	SECOND FLOOR POWER PLAN	08/29/2018	1	01-03-2020
EP-103	THIRD FLOOR POWER PLAN	08/29/2018	1	01-03-2020
EP-104	FOURTH FLOOR POWER PLAN	08/29/2018	1	01-03-2020
EP-105	FIFTH FLOOR POWER PLAN	08/29/2018	1	01-03-2020
EP-106	ROOF POWER PLAN	08/29/2018	1	01-03-2020
E-201	ENLARGED GUEST ROOM ELECTRICAL PLANS	08/29/2018		
E-202	ENLARGED GUEST ROOM ELECTRICAL PLANS	08/29/2018		
E-300.1	POWER RISER DIAGRAM	08/29/2018	2	01-03-2020
E-300.2	EMERGENCY/STAND-BY POWER RISER DIAGRAM	08/29/2018		
E-300B	POWER RISER WIRE SCHEDULE AND GENERAL NOTES	08/29/2018		
E-301	ENLARGED ELEVATOR PART PLAN	08/29/2018	1	11/26/2019



E-302	FIRE ALARM RISER DIAGRAMS AND NOTES	08/29/2018		
E-303	ELECTRICAL DETAILS	08/29/2018		
E-304	ELECTRICAL DETAILS	08/29/2018		
E-305	ELECTRICAL DETAILS	08/29/2018		
E-401	ELECTRICAL PANEL SCHEDULES	08/29/2018	2	01-03-2020
E-402	ELECTRICAL PANEL SCHEDULES	08/29/2018	1	01-03-2020
E-403	ELECTRICAL PANEL SCHEDULES	08/29/2018		
E-404	ELECTRICAL PANEL SCHEDULES	08/29/2018		
E-405	ELECTRICAL PANEL SCHEDULES	08/29/2018	1	01-03-2020
E-406	ELECTRICAL PANEL SCHEDULES	08/29/2018		
E-407	ELECTRICAL PANEL SCHEDULES	08/29/2018		
E-408	ELECTRICAL PANEL SCHEDULES	08/29/2018	1	01-03-2020
E-409	ELECTRICAL PANEL SCHEDULES	08/29/2018		

SCOPE OF WORK

CONVERSION OF AN EXISTING 5 STORY INDUSTRIAL BUILDING TO 5 STORY HOTEL.

STRUCTURAL REPAIR DRAWING LIST

SHEET NO.	SHEET NAME	DATE	REV. #	REV. DATE
SR-001	COVER SHEET	06/29/2018		
SR-002	STRUCTURAL REPAIR DRAWING LIST	06/29/2018		
SR-003	FRP NOTES	06/29/2018		
SR-101	EXISTING FIRST FLOOR DAMAGE & REPAIR PLAN	06/29/2018		
SR-102	EXISTING FIRST FLOOR DAMAGE LOCATION PICTURES	06/29/2018		
SR-103	EXISTING FIRST FLOOR DAMAGE LOCATION PICTURES	06/29/2018		
SR-104	EXISTING FIRST FLOOR DAMAGE LOCATION PICTURES	06/29/2018		
SR-105	DETAILS FOR REPAIR NUMBER 1P12/19	06/29/2018		
SR-201	EXISTING SECOND FLOOR DAMAGE & REPAIR PLAN	06/29/2018		
SR-202	EXISTING SECOND FLOOR DAMAGE LOCATION PICTURES	06/29/2018		
SR-203	EXISTING SECOND FLOOR DAMAGE LOCATION PICTURES	06/29/2018		



SR-204	EXISTING SECOND FLOOR DAMAGE LOCATION PICTURES	06/29/2018		
SR-205	EXISTING SECOND FLOOR DAMAGE LOCATION PICTURES	06/29/2018		
SR-206	FRP REPAIR ELEVATION	06/29/2018		
SR-207	FRP REPAIR ELEVATION	06/29/2018		
SR-301	EXISTING THIRD FLOOR DAMAGE & REPAIR PLAN	06/29/2018		
SR-302	EXISTING THIRD FLOOR DAMAGE LOCATION PICTURES	06/29/2018		
SR-303	EXISTING THIRD FLOOR DAMAGE LOCATION PICTURES	06/29/2018		
SR-304	EXISTING THIRD FLOOR DAMAGE LOCATION PICTURES	06/29/2018		
SR-305	EXISTING THIRD FLOOR DAMAGE LOCATION PICTURES	06/29/2018		
SR-306	EXISTING THIRD FLOOR DAMAGE LOCATION PICTURES	06/29/2018		
SR-307	EXISTING THIRD FLOOR DAMAGE LOCATION PICTURES	06/29/2018		
SR-308	EXISTING THIRD FLOOR DAMAGE LOCATION PICTURES	06/29/2018		
SR-309	EXISTING THIRD FLOOR DAMAGE LOCATION PICTURES	06/29/2018		
SCOPE OF WORK				
CONVERSION OF AN EXISTING 5 STORY INDUSTRIAL BUILDING TO 5 STORY HOTEL.				
STRUCTURAL REPAIR DRAWING LIST				
SHEET NO.	SHEET NAME	DATE	REV. #	REV. DATE
SR-310	EXISTING THIRD FLOOR DAMAGE LOCATION PICTURES	06/29/2018		
SR-311	EXISTING THIRD FLOOR DAMAGE LOCATION PICTURES	06/29/2018		
SR-312	EXISTING THIRD FLOOR DAMAGE LOCATION PICTURES	06/29/2018		
SR-313	EXISTING THIRD FLOOR DAMAGE LOCATION PICTURES	06/29/2018		
SR-314	EXISTING THIRD FLOOR DAMAGE LOCATION PICTURES	06/29/2018		



SR-315	EXISTING THIRD FLOOR DAMAGE LOCATION PICTURES	06/29/2018		
SR-316	EXISTING THIRD FLOOR DAMAGE LOCATION PICTURES	06/29/2018		
SR-401	EXISTING FOURTH FLOOR DAMAGE & REPAIR PLAN	06/29/2018		
SR-402	EXISTING FOURTH FLOOR DAMAGE LOCATION PICTURES	06/29/2018		
SR-403	EXISTING FOURTH FLOOR DAMAGE LOCATION PICTURES	06/29/2018		
SR-404	EXISTING FOURTH FLOOR DAMAGE LOCATION PICTURES	06/29/2018		
SR-405	EXISTING FOURTH FLOOR DAMAGE LOCATION PICTURES	06/29/2018		
SR-406	EXISTING FOURTH FLOOR DAMAGE LOCATION PICTURES	06/29/2018		
SR-407	EXISTING FOURTH FLOOR DAMAGE LOCATION PICTURES	06/29/2018		
SR-408	EXISTING FOURTH FLOOR DAMAGE LOCATION PICTURES	06/29/2018		
SR-409	EXISTING FOURTH FLOOR DAMAGE LOCATION PICTURES	06/29/2018		
SR-410	EXISTING FOURTH FLOOR DAMAGE LOCATION PICTURES	06/29/2018		
SR-411	EXISTING FOURTH FLOOR DAMAGE LOCATION PICTURES	06/29/2018		
SR-412	EXISTING FOURTH FLOOR DAMAGE LOCATION PICTURES	06/29/2018		
SR-413	EXISTING FOURTH FLOOR DAMAGE LOCATION PICTURES	06/29/2018		
SR-414	EXISTING FOURTH FLOOR DAMAGE LOCATION PICTURES	06/29/2018		
SCOPE OF WORK				
CONVERSION OF AN EXISTING 5 STORY INDUSTRIAL BUILDING TO 5 STORY HOTEL.				
STRUCTURAL REPAIR DRAWING LIST				
SHEET NO.	SHEET NAME	DATE	REV. #	REV. DATE
SR-501	EXISTING FIFTH FLOOR DAMAGE & REPAIR PLAN	06/29/2018		



SR-502	EXISTING FIFTH FLOOR DAMAGE LOCATION PICTURES	06/29/2018		
SR-503	EXISTING FIFTH FLOOR DAMAGE LOCATION PICTURES	06/29/2018		
SR-504	EXISTING FIFTH FLOOR DAMAGE LOCATION PICTURES	06/29/2018		
SR-505	EXISTING FIFTH FLOOR DAMAGE LOCATION PICTURES	06/29/2018		
SR-506	EXISTING FIFTH FLOOR DAMAGE LOCATION PICTURES	06/29/2018		
SR-507	EXISTING FIFTH FLOOR DAMAGE LOCATION PICTURES	06/29/2018		
SR-508	EXISTING FIFTH FLOOR DAMAGE LOCATION PICTURES	06/29/2018		
SR-509	EXISTING FIFTH FLOOR DAMAGE LOCATION PICTURES	06/29/2018		
SR-510	EXISTING FIFTH FLOOR DAMAGE LOCATION PICTURES	06/29/2018		
SR-511	EXISTING FIFTH FLOOR DAMAGE LOCATION PICTURES	06/29/2018		
SR-512	EXISTING FIFTH FLOOR DAMAGE LOCATION PICTURES	06/29/2018		
SR-513	EXISTING FIFTH FLOOR DAMAGE LOCATION PICTURES	06/29/2018		
SR-514	EXISTING FIFTH FLOOR DAMAGE LOCATION PICTURES	06/29/2018		
SR-701	EXISTING EAST ELEVATION DAMAGE & REPAIR	06/29/2018		
SR-702	EXISTING EAST ELEVATION DAMAGE LOCATION PICTURES	06/29/2018		
SR-703	EXISTING EAST ELEVATION DAMAGE LOCATION PICTURES	06/29/2018		
SR-704	EXISTING WEST ELEVATION DAMAGE & REPAIR	06/29/2018		
SR-705	EXISTING SOUTH ELEVATION DAMAGE & REPAIR	06/29/2018		
SR-706	EXISTING SOUTH ELEVATION DAMAGE LOCATION PICTURES	06/29/2018		
SR-707	EXISTING NORTH ELEVATION DAMAGE & REPAIR	06/29/2018		
SR-708	EXISTING NORTH ELEVATION DAMAGE LOCATION PICTURES	06/29/2018		
SCOPE OF WORK				



CONVERSION OF AN EXISTING 5 STORY INDUSTRIAL BUILDING TO 5 STORY HOTEL.				
STRUCTURAL REPAIR DRAWING LIST				
SHEET NO.	SHEET NAME	DATE	REV. #	REV. DATE
SR-709	EXISTING NORTH ELEVATION DAMAGE LOCATION PICTURES	06/29/2018		
SR-710	EXISTING NORTH ELEVATION DAMAGE LOCATION PICTURES	06/29/2018		
SR-711	EXISTING NORTH ELEVATION DAMAGE LOCATION PICTURES	06/29/2018		
SR-712	EXISTING NORTH ELEVATION DAMAGE LOCATION PICTURES	06/29/2018		
SR-713	EXISTING NORTH ELEVATION DAMAGE LOCATION PICTURES	06/29/2018		
SR-714	EXISTING NORTH ELEVATION DAMAGE LOCATION PICTURES	06/29/2018		
SR-715	EXISTING NORTH ELEVATION DAMAGE LOCATION PICTURES	06/29/2018		
SR-716	EXISTING NORTH ELEVATION DAMAGE LOCATION PICTURES	06/29/2018		
SR-901	REPAIR DETAILS	06/29/2018		
SR-902	SECOND FLOOR PLAN - FRP REPAIR	06/29/2018		
SR-903	THIRD FLOOR PLAN - FRP REPAIR	06/29/2018		
SR-904	FOURTH FLOOR PLAN - FRP REPAIR	06/29/2018		
SR-905	FIFTH FLOOR PLAN - FRP REPAIR	06/29/2018		
SR-906	FRP REPAIR SECTION	06/29/2018		



ATTACHMENT B

A GUIDE FOR THE PREPARATION OF MATERIALS SAMPLES CONSTRUCTION DETAIL PANELS

As part of the Boston Redevelopment Authority's Design Review Procedures, a full-size materials sample or mock-up Panel is required. If not previously approved under the Contract Documents stage, samples of all materials must be approved prior to their inclusion in such a panel.

Site inspection stage approval is contingent on Authority review and approval of on-site materials panels that demonstrate the construction details of the project.

Materials panels shall demonstrate all exterior material selections, including variations in color, finish, and source.

Detailing of dimensional profiles of all exterior trim including: cornices, belting, contrasting, banding, soffit treatment, jambs, returns, copings, and all window walls including frames, subdivisions, and jamb, head and sill details, shall be presented.

Brick and all facing material (granite, cast stone, marble, terra cotta, metal, et al) sample panels shall include joint details, patterning out of the norm or as requested, and masonry jamb, head and sill details.

Where mortar or grouting is used, panels shall show intended tooling, finish and color.

Where adhesive or caulking agents are used, panels shall show intended tooling, finish, color and spacing between contiguous materials, and manufacturer specifications shall be furnished.

In the case of windows, or replacement/ rehabilitation / repair projects, or where the abutting context is deemed significant and is immediate, assemblies shall be presented *in situ* or against areas of the existing details/ materials which they are intended to match.

All such material panels shall be presented in an assembly large enough to assess finished construction façade color, patterning and joint details, in a manner representing actual designed combinations. Such panel shall be erected in the manner most able to represent lighting, orientation, context, and weather conditions for the overall Project.



LOCUS
SCALE: 1" = 500'



11/30/2020

BPDA Article 80 Approval with Provisos

See attached BPDA List of Provisos for all conditions governing approval and next steps of mock up process

CIVIL ENGINEER: **PVI SITE DESIGN**
PVI Site Design, LLC
Civil Engineering - Land Entitlements
Master Planning - Project Management
337-206-1030

PROJECT: **HOTEL REDEVELOPMENT**
155 PORTER STREET, EAST BOSTON, MA

CLIENT/APPLICANT: **HUDSON 62 REALTY LLC**
440 BEDFORD ST, LEXINGTON, MA 01824

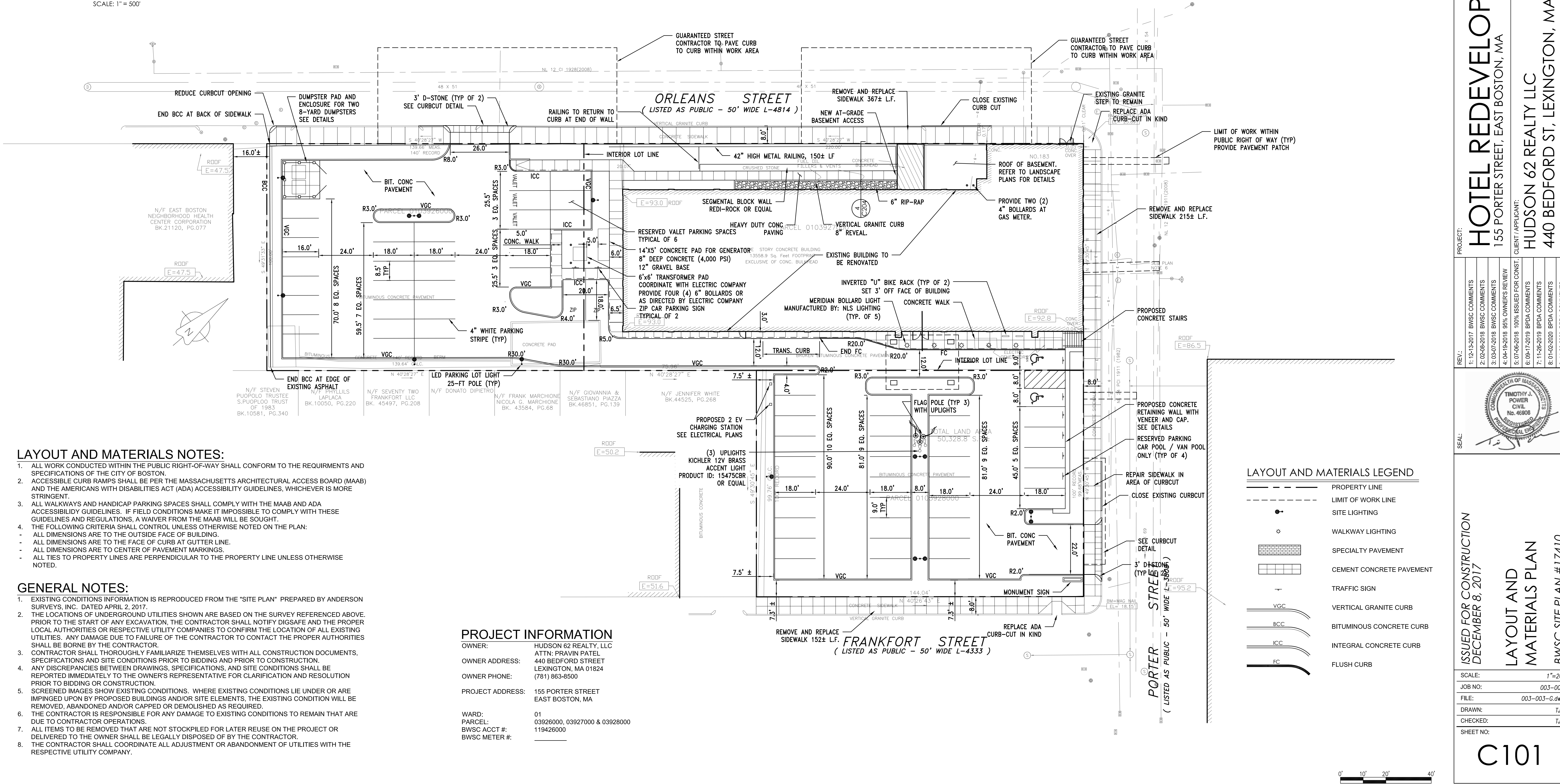

LAYOUT AND MATERIALS NOTES:

- ALL WORK CONDUCTED WITHIN THE PUBLIC RIGHT-OF-WAY SHALL CONFORM TO THE REQUIREMENTS AND SPECIFICATIONS OF THE CITY OF BOSTON.
- ACCESSIBLE CURB RAMPS SHALL BE PER THE MASSACHUSETTS ARCHITECTURAL ACCESS BOARD (MAAB) AND THE AMERICANS WITH DISABILITIES ACT (ADA) ACCESSIBILITY GUIDELINES, WHICHEVER IS MORE STRINGENT.
- ALL WALKWAYS AND HANDICAP PARKING SPACES SHALL COMPLY WITH THE MAAB AND ADA ACCESSIBILITY GUIDELINES. IF FIELD CONDITIONS MAKE IT IMPOSSIBLE TO COMPLY WITH THESE GUIDELINES AND REGULATIONS, A WAIVER FROM THE MAAB WILL BE SOUGHT.
- THE FOLLOWING CRITERIA SHALL CONTROL UNLESS OTHERWISE NOTED ON THE PLAN:
 - ALL DIMENSIONS ARE TO THE OUTSIDE FACE OF BUILDING.
 - ALL DIMENSIONS ARE TO THE FACE OF CURB AT GUTTER LINE.
 - ALL DIMENSIONS ARE TO CENTER OF PAVEMENT MARKINGS.
 - ALL TIES TO PROPERTY LINES ARE PERPENDICULAR TO THE PROPERTY LINE UNLESS OTHERWISE NOTED.

GENERAL NOTES:

- EXISTING CONDITIONS INFORMATION IS REPRODUCED FROM THE "SITE PLAN" PREPARED BY ANDERSON SURVEYS, INC. DATED APRIL 2, 2017.
- THE LOCATIONS OF UNDERGROUND UTILITIES SHOWN ARE BASED ON THE SURVEY REFERENCED ABOVE. PRIOR TO THE START OF ANY EXCAVATION, THE CONTRACTOR SHALL NOTIFY DIGSAFE AND THE PROPER LOCAL AUTHORITIES OR RESPECTIVE UTILITY COMPANIES TO CONFIRM THE LOCATION OF ALL EXISTING UTILITIES. ANY DAMAGE DUE TO FAILURE OF THE CONTRACTOR TO CONTACT THE PROPER AUTHORITIES SHALL BE BORNE BY THE CONTRACTOR.
- CONTRACTOR SHALL THOROUGHLY FAMILIARIZE THEMSELVES WITH ALL CONSTRUCTION DOCUMENTS, SPECIFICATIONS AND SITE CONDITIONS PRIOR TO BIDDING AND PRIOR TO CONSTRUCTION.
- ANY DISCREPANCIES BETWEEN DRAWINGS, SPECIFICATIONS, AND SITE CONDITIONS SHALL BE REPORTED IMMEDIATELY TO THE OWNER'S REPRESENTATIVE FOR CLARIFICATION AND RESOLUTION PRIOR TO BIDDING OR CONSTRUCTION.
- SCREENED IMAGES SHOW EXISTING CONDITIONS. WHERE EXISTING CONDITIONS LIE UNDER OR ARE IMPINGED UPON BY PROPOSED BUILDINGS AND/OR SITE ELEMENTS, THE EXISTING CONDITION WILL BE REMOVED, ABANDONED AND/OR CAPPED OR DEMOLISHED AS REQUIRED.
- THE CONTRACTOR IS RESPONSIBLE FOR ANY DAMAGE TO EXISTING CONDITIONS TO REMAIN THAT ARE DUE TO CONTRACTOR OPERATIONS.
- ALL ITEMS TO BE REMOVED THAT ARE NOT STOCKPILED FOR LATER REUSE ON THE PROJECT OR DELIVERED TO THE OWNER SHALL BE LEGALLY DISPOSED OF BY THE CONTRACTOR.
- THE CONTRACTOR SHALL COORDINATE ALL ADJUSTMENT OR ABANDONMENT OF UTILITIES WITH THE RESPECTIVE UTILITY COMPANY.

PROJECT INFORMATION

OWNER: HUDSON 62 REALTY, LLC
ATTN: PRAVIN PATEL
440 BEDFORD STREET
LEXINGTON, MA 01824
(781) 863-8500

OWNER ADDRESS: 440 BEDFORD STREET
LEXINGTON, MA 01824
(781) 863-8500

OWNER PHONE: (781) 863-8500

PROJECT ADDRESS: 155 PORTER STREET
EAST BOSTON, MA

WARD: 01
PARCEL: 03926000, 03927000 & 03928000
BWSACCT #: 119426000
BWSMETER #:

LAYOUT AND MATERIALS LEGEND

---	PROPERTY LINE
- - - -	LIMIT OF WORK LINE
•	SITE LIGHTING
⊙	WALKWAY LIGHTING
[Pattern]	SPECIALTY PAVEMENT
[Pattern]	CEMENT CONCRETE PAVEMENT
T	TRAFFIC SIGN
VGC	VERTICAL GRANITE CURB
BCC	BITUMINOUS CONCRETE CURB
ICC	INTEGRAL CONCRETE CURB
FC	FLUSH CURB

REV.:

1: 12-13-2017	BVSC COMMENTS
2: 02-08-2018	BVSC COMMENTS
3: 03-07-2018	BVSC COMMENTS
4: 04-19-2018	95% OWNER'S REVIEW
5: 07-06-2018	100% ISSUED FOR CONST.
6: 09-17-2019	BPDA COMMENTS
7: 11-26-2019	BPDA COMMENTS
8: 01-02-2020	BPDA COMMENTS
9: 11-20-2020	BPDA COMMENTS

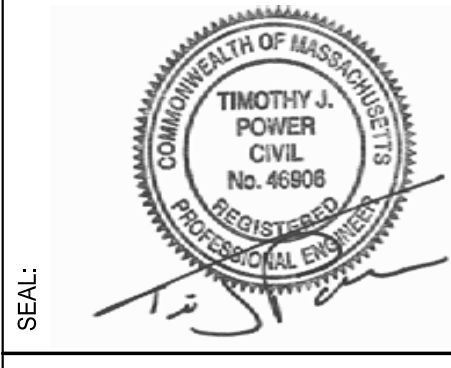

ISSUED FOR CONSTRUCTION
DECEMBER 8, 2017

LAYOUT AND MATERIALS PLAN
BWSACCT PLAN #17410

SCALE: 1" = 20'
JOB NO: 003-003
FILE: 003-003-G.dwg
DRAWN: TJP
CHECKED: TJP
SHEET NO:

C101



SEWER FLOW CALCULATIONS:

SEWER DESIGN FLOWS BASED ON 310 CMR 15

EXISTING USE:	INDUSTRIAL BUILDING (540 PEOPLE)
UNIT FLOW:	15 GPD / PERSON
EXISTING FLOW:	8,100 GPD
PROPOSED USE:	123 ROOM HOTEL + 130 SEAT RESTAURANT
UNIT FLOW:	110 GPD PER ROOM 35 GPD PER SEAT
HOTEL FLOW:	13,530 GPD
RESTAURANT FLOW:	4,550 GPD
TOTAL NEW FLOW:	18,080 GPD
NET CHANGE:	+9,980 GPD (SEWER FLOW INCREASE)
GREASE TRAP SIZING:	15 GAL PER SEAT
UNIT FLOW:	1,950 GAL. → 2,000 GAL TRAP PROPOSED.

DRAINAGE CALCULATIONS SUMMARY

(FULL DRAINAGE CALCULATIONS WERE PREPARED USING HYDROCAD V10)

1" STORM EVALUATION	
TOTAL IMPERVIOUS AREA:	41,835 SF
1" STORM VOLUME:	3,486 CF
RECHARGE VOLUME:	
CHAMBERS:	
VOL. / CHAMBER AT 27" FULL:	45.4 CUFT (PER STORMTECH)
64 CHAMBERS:	45.4 X 64 = 2,906 CUFT
STONE:	
DIMENSIONS: 60.58' X 39.5' X 33" =	6,580 CUFT
LESS CHAMBERS: 6,580 - 2,906 =	3,674 CUFT
30% VOIDS: 3,674 X 0.3 =	1,102 CUFT
TOTAL:	2,906 + 1,102 = 4,008 CUFT
4,008 > 3,486 = OK	

INSPECTION SIGN-OFF SCHEDULE

ITEM NO.	DESCRIPTION OF SERVICE	QTY.	BWSC INSPECTOR DATE	COMMENTS
1	SANITARY PIPE INSTALLATION	68'		
2	SANITARY MANHOLE INSTALLATION	1		
3	SANITARY CHIMNEY CONNECTION	1		
4	REMOVE SEWER SERVICE	1		
5	GREASE TRAP INSTALLATION	1		
6	VIDEO NEW SANITARY PIPES	1		
7	OUTLET CONTROL STRUCTURE (OCS)	1		
8	DRAINAGE PIPE INSTALLATION	320'		
9	DYE TEST SEWER	1		
10	DRAINAGE CHIMNEY CONNECTION	1		
11	DON'T DUMP PLAQUE INSTALLATION	6		
12	VIDEO NEW DRAIN PIPES	1		
13	UNDERGROUND RECHARGE SYSTEM	1		
14	DYE TEST NEW DRAINAGE SYSTEM	1		
15	FIELD CONNECTION AT MAIN	1		
16	6" FIRE SERVICE INSTALLATION	1		
17	4" DOMESTIC SERVICE INSTALLATION	1		
18	BACKFLOW CONNECTION	1		
19	NEW 2" METER INSTALLATION	1		
20	TRENCH DRAIN	1		
21	DRAIN MANHOLE 1	1		
22	DRAIN MANHOLE 2	1		
23	DRAIN MANHOLE 3	1		
24	DRAIN MANHOLE 4	1		
25	DRAIN MANHOLE 5 (DIVERSION MANHOLE)	1		
26	DRAIN MANHOLE 6 (SUMP AND HOOD)	1		
27	REMOVE 4" FIRE SERVICE	1		
28	REMOVE 4" FIRE SERVICE	1		
29	REMOVE 4" FIRE SERVICE	1		
30	SHALLOW CATCH BASIN PCB1	1		
31	SHALLOW CATCH BASIN PCB2	1		
32	SHALLOW CATCH BASIN PCB3	1		
33	TYP CATCH BASIN WITH OIL TRAP PCB4	1		
34	TYP CATCH BASIN WITH OIL TRAP PCB5	1		

GRADING AND UTILITY NOTES:

- EXISTING CONDITIONS INFORMATION IS REPRODUCED FROM THE "SITE PLAN" PREPARED BY ANDERSON SURVEYS, INC. DATED APRIL 2, 2017.
- ALL ELEVATIONS REFER TO BOSTON CITY BASE.
- WHERE PROPOSED GRADES MEET EXISTING GRADES, CONTRACTOR SHALL BLEND GRADES TO PROVIDE A SMOOTH TRANSITION BETWEEN EXISTING AND NEW WORK. PONDING AT TRANSITION AREAS WILL NOT BE ALLOWED.
- ENSURE ALL EXISTING (TO REMAIN) AND PROPOSED MANHOLE COVERS PROPERLY IDENTIFY UTILITY SERVICED.
- CONTRACTOR SHALL VERIFY EXISTING GRADES AND NOTIFY OWNER'S REPRESENTATIVE OF ANY DISCREPANCIES.
- CONTRACTOR SHALL ADJUST ALL UTILITY ELEMENTS MEANT TO BE FLUSH WITH GRADE (CLEAN-OUTS, UTILITY MANHOLES, ETC) THAT IS AFFECTED BY SITE WORK OR GRADE CHANGES, WHETHER SPECIFICALLY NOTED ON PLANS OR NOT.
- ALL CONSTRUCTION TO BE DONE IN ACCORDANCE WITH BOSTON WATER AND SEWER STANDARDS.
- WHERE EXISTING UTILITY IS FOUND TO CONFLICT WITH THE PROPOSED WORK, THE LOCATION ELEVATION, AND SIZE OF THE UTILITY SHALL BE ACCURATELY DETERMINED WITHOUT DELAY BY THE CONTRACTOR AND THE INFORMATION FURNISHED TO THE ENGINEER FOR RESOLUTION OF THE CONFLICT.
- THE CONTRACTOR SHALL ALTER THE MASONRY OF THE TOP SECTIONS OF ALL EXISTING DRAINAGE STRUCTURES AS NECESSARY FOR CHANGES IN GRADE, AND RESET ALL FRAMES, GRATES, AND BOXES TO THE PROPOSED FINISHED GRADE.
- PROTECT AND MAINTAIN EXISTING ON-SITE DRAINAGE STRUCTURES AND PIPES UNLESS OTHERWISE NOTED.
- DRAINAGE PIPES SHALL BE SDR 35 UNLESS OTHERWISE NOTED.
- ALL SEWER PIPES SHALL BE SDR 35 UNLESS OTHERWISE NOTED.
- ALL WATER PIPES 4" OR LARGER SHALL BE CLASS 56, ZINC COATED DUCTILE IRON.
- ALL SOILS REMOVED FROM THE SITE SHALL BE DISPOSED OF BY THE CONTRACTOR AT CONTRACTOR'S EXPENSE. SOILS MAY BE CONTAMINATED. CONTRACTOR SHALL CONSULT WITH OWNER'S LICENSED SITE PROFESSIONAL (LSP) PRIOR TO ANY EXCAVATION TO CONFIRM EXCAVATION AND DISPOSAL REQUIREMENTS.

TV INSPECTION OF SEWERS & DRAINS

- THE CONTRACTOR SHALL FURNISH ALL EQUIPMENT, LABOR, MATERIALS, AND SUPERVISION AS REQUIRED TO INSPECT THE INTERIOR OF ALL SEWERS AND DRAINS, PROVIDE VIDEO RECORDINGS WITH VOICE DESCRIPTIONS AS WELL AS FULL INSPECTION REPORTS, AND ALL OTHER APPURTENANT WORK, WITHIN THE LIMITS SHOWN ON THE DRAWINGS, AS DIRECTED BY THE ENGINEER, AND AS SPECIFIED IN THE BOSTON WATER & SEWER (BWSC) SPECIFICATION "TELEVISION INSPECTION OF SEWERS AND DRAINS" AS LATEST REVISED AVAILABLE AT: [HTTP://WWW.BWSC.ORG/REGULATIONS/CONSTRUCTION_SPECS/CONSTRUCTION_SPECS](http://www.bwsc.org/regulations/construction_specs/construction_specs)
- PIPES SHALL NOT BE INSPECTED UNTIL COMPLETELY CLEANED IN ACCORDANCE WITH THE SPECIFICATION NOTED IN #1 AND TO THE SATISFACTION OF THE BWSC INSPECTOR AND OWNER'S REPRESENTATIVE.

FOR BWSC USE ONLY
 PARCEL #: 0103926000
 PARCEL #: 0103927000
 PARCEL #: 0103928000

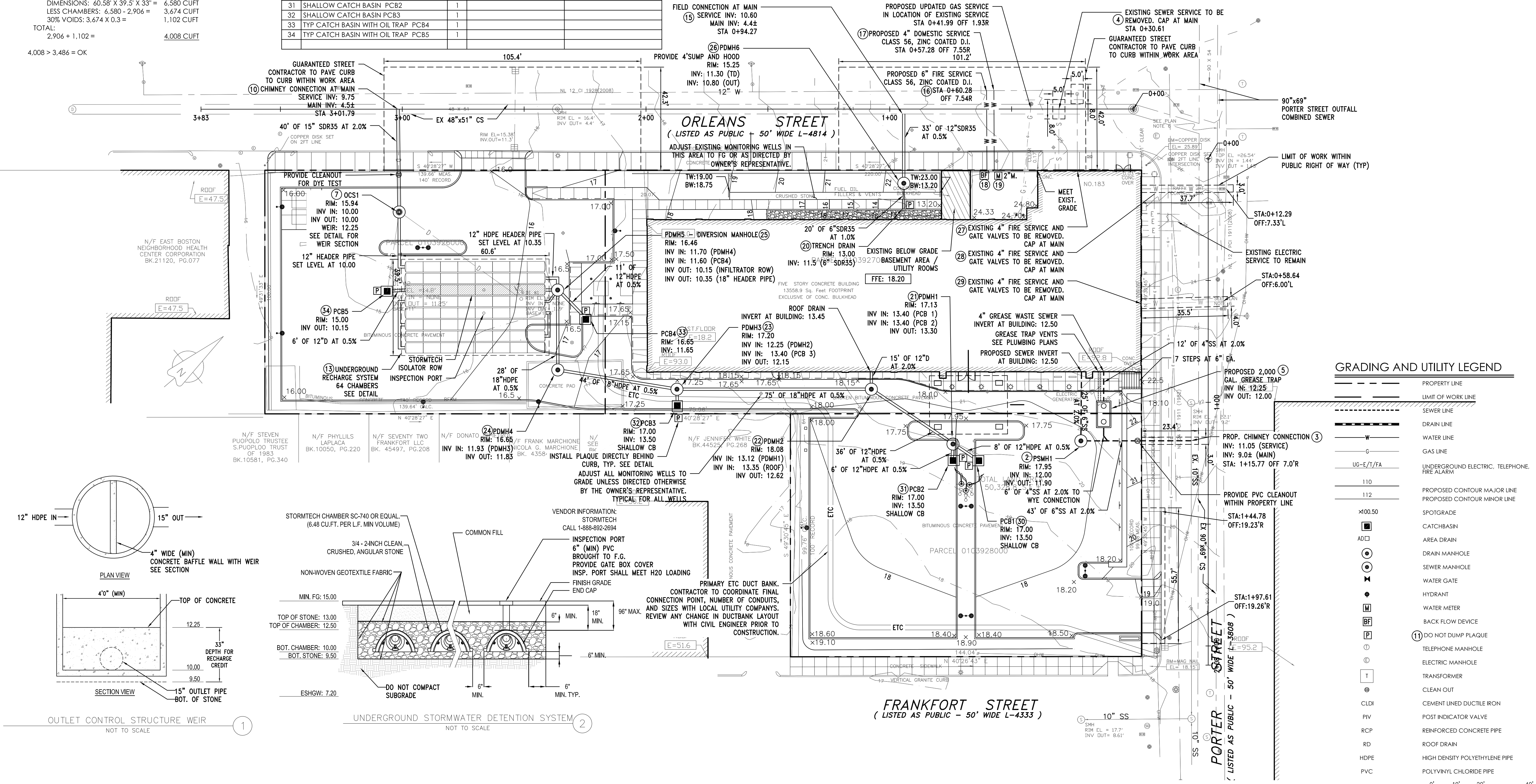

GRADING AND UTILITY LEGEND

	PROPERTY LINE
	LIMIT OF WORK LINE
	SEWER LINE
	DRAIN LINE
	WATER LINE
	GAS LINE
	UNDERGROUND ELECTRIC, TELEPHONE, FIRE ALARM
	PROPOSED CONTOUR MAJOR LINE
	PROPOSED CONTOUR MINOR LINE
	SPOTGRADE
	CATCHBASIN
	AREA DRAIN
	DRAIN MANHOLE
	SEWER MANHOLE
	WATER GATE
	HYDRANT
	WATER METER
	BACK FLOW DEVICE
	TELEPHONE MANHOLE
	ELECTRIC MANHOLE
	TRANSFORMER
	CLEAN OUT
	CEMENT LINED DUCTILE IRON
	POST INDICATOR VALVE
	REINFORCED CONCRETE PIPE
	ROOF DRAIN
	HIGH DENSITY POLYETHYLENE PIPE
	POLYVINYL CHLORIDE PIPE

CIVIL ENGINEER: PVI SITE DESIGN, LLC
 PVI Site Design, LLC
 Civil Engineering - Land Enhancements
 Master Planning - Project Management
 339-206-1030

PROJECT: HOTEL REDEVELOPMENT
 155 PORTER STREET, EAST BOSTON, MA
 CLIENT/APPLICANT: HUDSON 62 REALTY LLC
 440 BEDFORD ST, LEXINGTON, MA 01824

REV:
 1: 12-13-2017 BWSC COMMENTS
 2: 02-08-2018 BWSC COMMENTS
 3: 03-07-2018 BWSC COMMENTS
 4: 04-19-2018 85% OWNER'S REVIEW
 5: 07-06-2018 100% ISSUED FOR CONST.
 6: 09-17-2019 BPOA COMMENTS
 7: 11-26-2019 BPOA COMMENTS
 8: 01-02-2020 BPOA COMMENTS

SEAL: TIMOTHY J. POWER, CIVIL ENGINEER, No. 48909

ISSUED FOR CONSTRUCTION
 DECEMBER 8, 2017

GRADING AND UTILITY PLAN
 BWSC SITE PLAN #17410

SCALE: 1"=20'
JOB NO: 003-003
FILE: 003-003-G.dwg
DRAWN: TJP
CHECKED: TJP
SHEET NO: C102

REV:	1-08-17-2019 BPDA COMMENTS
	2-11-26-2019 BPDA COMMENTS
	3-12-25-2019 BPDA COMMENTS
	4-01-02-2020 GREEN ROOF

SCALE:	AS NOTED
JOB NO:	1916
FILE:	1916-L.dwg
DRAWN:	RAB
CHECKED:	RAB
SHEET NO:	L101

100% CONSTRUCTION DOCUMENTS
DECEMBER 8, 2017

LANDSCAPE PLAN, NOTES, DETAILS AND SCHEDULE

SCALE:	AS NOTED
JOB NO:	1916
FILE:	1916-L.dwg
DRAWN:	RAB
CHECKED:	RAB
SHEET NO:	L101

L101

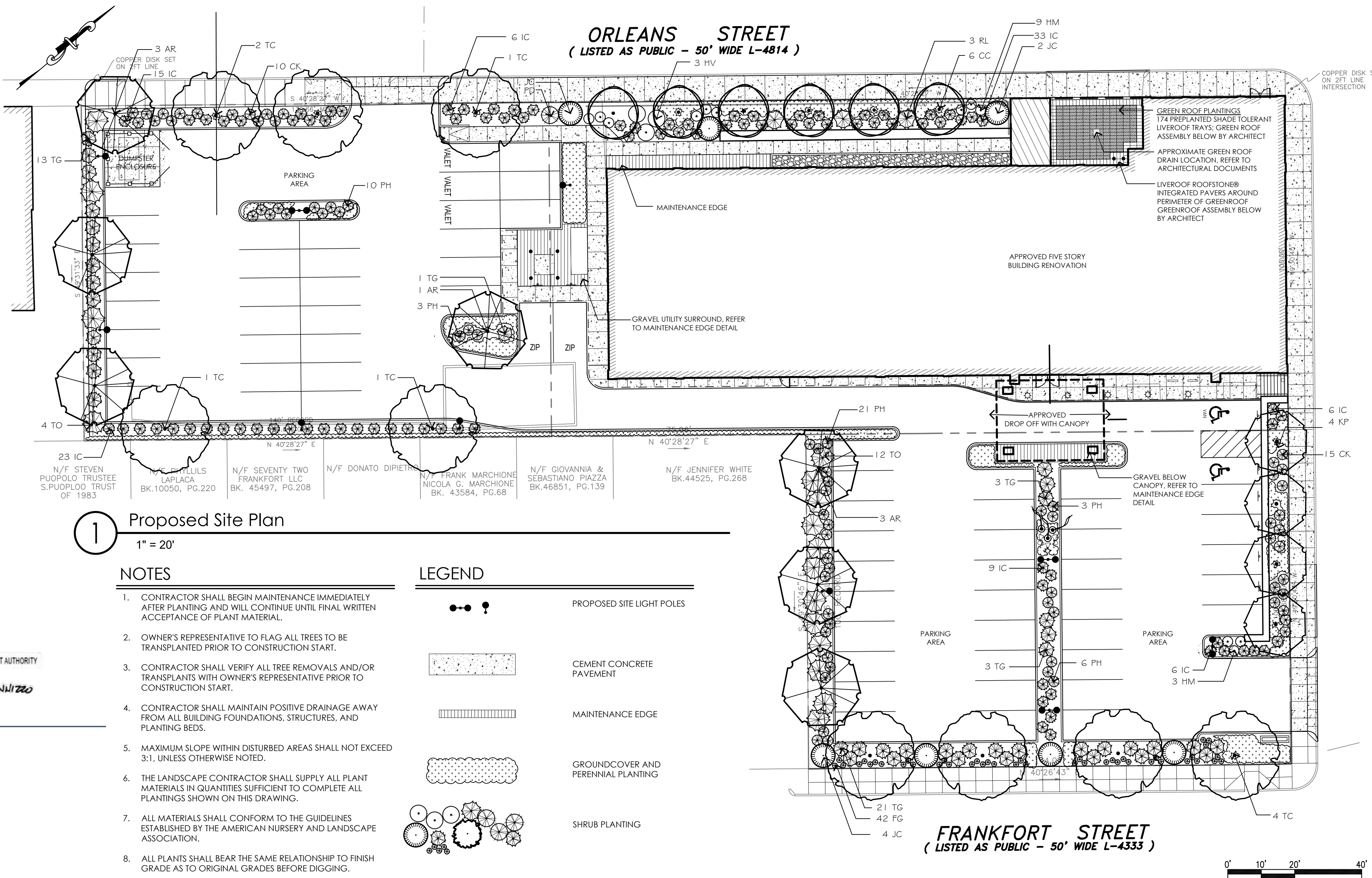

1 Proposed Site Plan
1" = 20'

NOTES

- CONTRACTOR SHALL BEGIN MAINTENANCE IMMEDIATELY AFTER PLANTING AND WILL CONTINUE UNTIL FINAL WRITTEN ACCEPTANCE OF PLANT MATERIAL.
- OWNER'S REPRESENTATIVE TO FLAG ALL TREES TO BE TRANSPLANTED PRIOR TO CONSTRUCTION START.
- CONTRACTOR SHALL VERIFY ALL TREE REMOVALS AND/OR TRANSPLANTS WITH OWNER'S REPRESENTATIVE PRIOR TO CONSTRUCTION START.
- CONTRACTOR SHALL MAINTAIN POSITIVE DRAINAGE AWAY FROM ALL BUILDING FOUNDATIONS, STRUCTURES, AND PLANTING BEDS.
- MAXIMUM SLOPE WITHIN DISTURBED AREAS SHALL NOT EXCEED 3:1, UNLESS OTHERWISE NOTED.
- THE LANDSCAPE CONTRACTOR SHALL SUPPLY ALL PLANT MATERIALS IN QUANTITIES SUFFICIENT TO COMPLETE ALL PLANTINGS SHOWN ON THIS DRAWING.
- ALL MATERIALS SHALL CONFORM TO THE GUIDELINES ESTABLISHED BY THE AMERICAN NURSERY AND LANDSCAPE ASSOCIATION.
- ALL PLANTS SHALL BEAR THE SAME RELATIONSHIP TO FINISH GRADE AS TO ORIGINAL GRADES BEFORE DIGGING.
- ALL PLANTS TO BE BALLED IN BURLAP OR CONTAINERIZED.
- MULCH FOR PLANTED AREAS TO BE AGED PINE BARK; PARTIALLY DECOMPOSED, DARK BROWN IN COLOR AND FREE OF WOOD CHIPS THICKER THAN 1/4 INCH.
- PLANTING SOIL MIX: LOAM THOROUGHLY INCORPORATED WITH ROTTED MANURE PROPORTIONED 5 C.Y. TO 1 C.Y. OR EQUIVALENT. FERTILIZER ADDED PER RECOMMENDED RATES OF SOILS ANALYSIS.
- THE LANDSCAPE CONTRACTOR SHALL GUARANTEE ALL PLANT MATERIALS FOR ONE (1) FULL YEAR FROM DATE OF ACCEPTANCE.
- ALL PLANT MATERIALS ARE SUBJECT TO THE APPROVAL OF THE OWNER'S REPRESENTATIVE, AT THE NURSERY, AND AT THE SITE.
- ALL AREAS OF THE SITE WHICH HAVE BEEN DISTURBED AND NOT OTHERWISE DEVELOPED SHALL BE LOAMED AND SEEDING WITH A MINIMUM DEPTH OF 6" DEPTH TOPSOIL.
- PLANT SPECIES AS INDICATED IN THE PLANT LIST ARE SUGGESTIONS ONLY. FINAL SELECTION OF SPECIES SHALL OCCUR AT THE TIME OF PLANT PURCHASE, DEPENDING ON AVAILABILITY. PLANT SIZE AND QUANTITY SHALL NOT CHANGE WITHOUT APPROVAL OF OWNER'S REPRESENTATIVE.

LEGEND

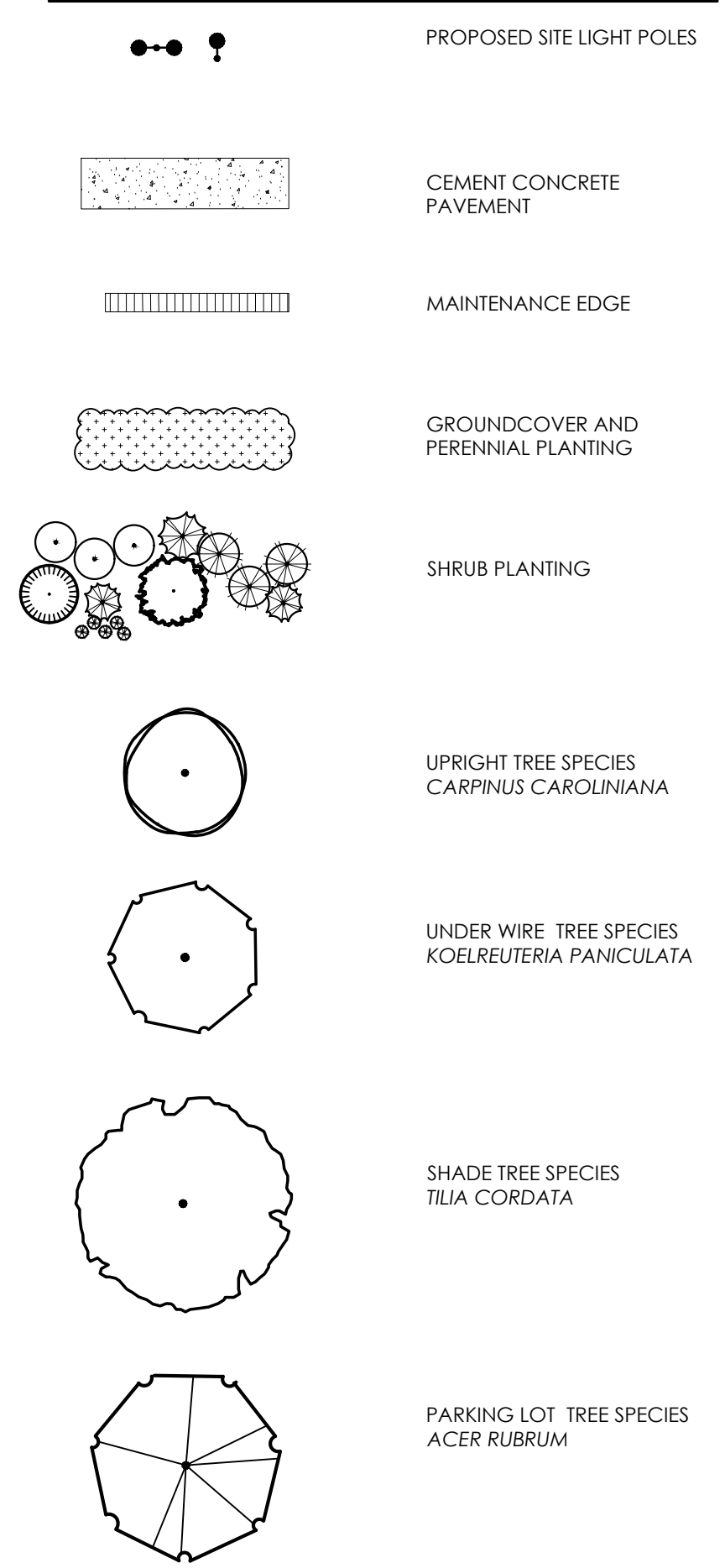

SUGGESTED PLANT SCHEDULE

*DROUGHT TOLERANT SPECIES PER LOCAL NURSERY CATALOGS, EXTENSION SVCS.

SYMBOL	BOTANICAL NAME	COMMON NAME	QTY	SIZE	COMMENT
DECIDUOUS TREES					
AR	ACER RUBRUM	RED MAPLE	7	2-2 1/2" CAL.	
KP	KOELREUTERIA PANICULATA*	GOLDENRAINTREE	4	2-2 1/2" CAL.	
TC	TILIA CORDATA*	LINDEN	9	2-2 1/2" CAL.	
CC	CARPINUS CAROLINIANA*	AMERICAN HORNBEAM	6	2-2 1/2" CAL.	
SHRUBS					
HV	HAMAMELIS VIRGINIANA	WITCHHAZEL	3	4-5' HT, HEAVY	FULL SUN/SHADE
HM	HYDRANGEA MACROPHYLLA 'TWIST-N-SHOUT'	REBLOOMING LACECAP HYDRANGEA	12	3 GALLON	PART SHADE
IC	ILEX CRENATA 'BEEHIVE'	BEEHIVE HOLLY	98	3 GALLON	FULL SUN/SHADE
JC	JUNIPERUS CHINENSIS 'BLUE POINT'	BLUE POINT JUNIPER	7	5-6" B&B	FULL SUN
RL	RHODODENDRON X LAETEVIRENS (WILSON)*	RHODODENDRON	3	5 GALLON	FULL SUN/SHADE
TG	TAXUS CUSPIDATA 'GREENWAVE'	GREENWAVE YEW	41	18-24" B&B	FULL SUN/SHADE
TO	THUJA OCCIDENTALIS 'TECHNY'	ARBORVITAE	16	6-7" B&B	FULL SUN
ORNAMENTAL GRASSES					
CK	CALAMAGROSTIS 'KARL FOERSTER'	FEATHER REED GRASS	25	1 GALLON	
FG	FESTUCA GLAUCA*	BLUE FESCUE	42	2 GALLON	
PD	PANICUM VIRGATUM 'DALLAS BLUES'	LARGE SWITCH GRASS	1	1 GALLON	
PH	PANICUM VIRGATUM 'HEAVY METAL'	SMALL SWITCH GRASS	43	2 GALLON	
PERENNIALS AND GROUNDCOVER					
	ACHILLEA SP.*	YARROW	100	1 GALLON	
	ASTER DIVARICATUS*	WHITE WOOD ASTER	100	1 GALLON	
	ECHINOPS RITRO*	GLOBE THISTLE	100	1 GALLON	
	HEDERA HELIX 'BALTICA'	ENGLISH IVY	100	1 GALLON	FULL SHADE
	HEMEROCALLIS SP.*	DAYLILY	100	1 GALLON	FULL SUN/SHADE
	HOSTA SP.*	HOSTA	100	1 GALLON	FULL SUN/SHADE
	LIRIOPE MUSCARI*	LILYTURF	100	1 GALLON	FULL SUN/SHADE
	PEROVSKIA ATRIPLICIFOLIA*	RUSSIAN SAGE	100	1 GALLON	FULL SUN/SHADE
	PHLOX SUBULATA*	MOSS PHLOX	100	1 GALLON	
	RUDBECKIA LACINIATA*	CUTLEAF CONEFLOWER	100	1 GALLON	
	STACHYS BYZANTINA*	LAMB'S EARS	100	1 GALLON	
	VINCA MINOR*	PERIWINKLE	100	1 GALLON	FULL SHADE
	YUCCA FILAMENTOSA*	ADAM'S NEEDLE	100	1 GALLON	

GREEN ROOF PLANTINGS

- GREEN ROOF SHALL BE PRE-PLANTED LIVEROOF STANDARD MODULES AS MANUFACTURED BY LIVEROOF, LLC, 14109 CLEVELAND ST, NUNICA MI 49448 USA, 1-616-842-1392, SALES@LIVEROOF.COM, HTTPS://LIVEROOF.COM
- PLANT SPECIES SHALL BE SELECTED FOR LOCAL ZONE, DROUGHT TOLERANCE, AND SHADE TOLERANCE. INVASIVE PLANT SPECIES SHALL NOT BE USED.
- MODULE INFORMATION:
 - SOIL DEPTH: APPROXIMATELY 4 1/2"
 - MODULE SIZE (PLASTIC): 1' X 2' X 3 1/2"
 - SATURATED WEIGHT: APPROXIMATELY 29 LBS PER SQUARE FOOT
 - DRY WEIGHT: APPROXIMATELY 20 POUNDS PER SQUARE FOOT
 - *SOIL DRY WEIGHTS MAY VARY REGIONALLY DEPENDING UPON THE LOCALLY SOURCED AGGREGATES.
 - CONFIRM DRY WEIGHTS WITH LOCAL LIVEROOF LICENSED GROWER.
- ROOF ASSEMBLY BELOW MODULES (WATERPROOFING, INSULATION, ETC) SHALL BE SELECTED IN COORDINATION WITH THE PROJECT ARCHITECT

3 TYPICAL DECIDUOUS TREE PLANTING
NTS

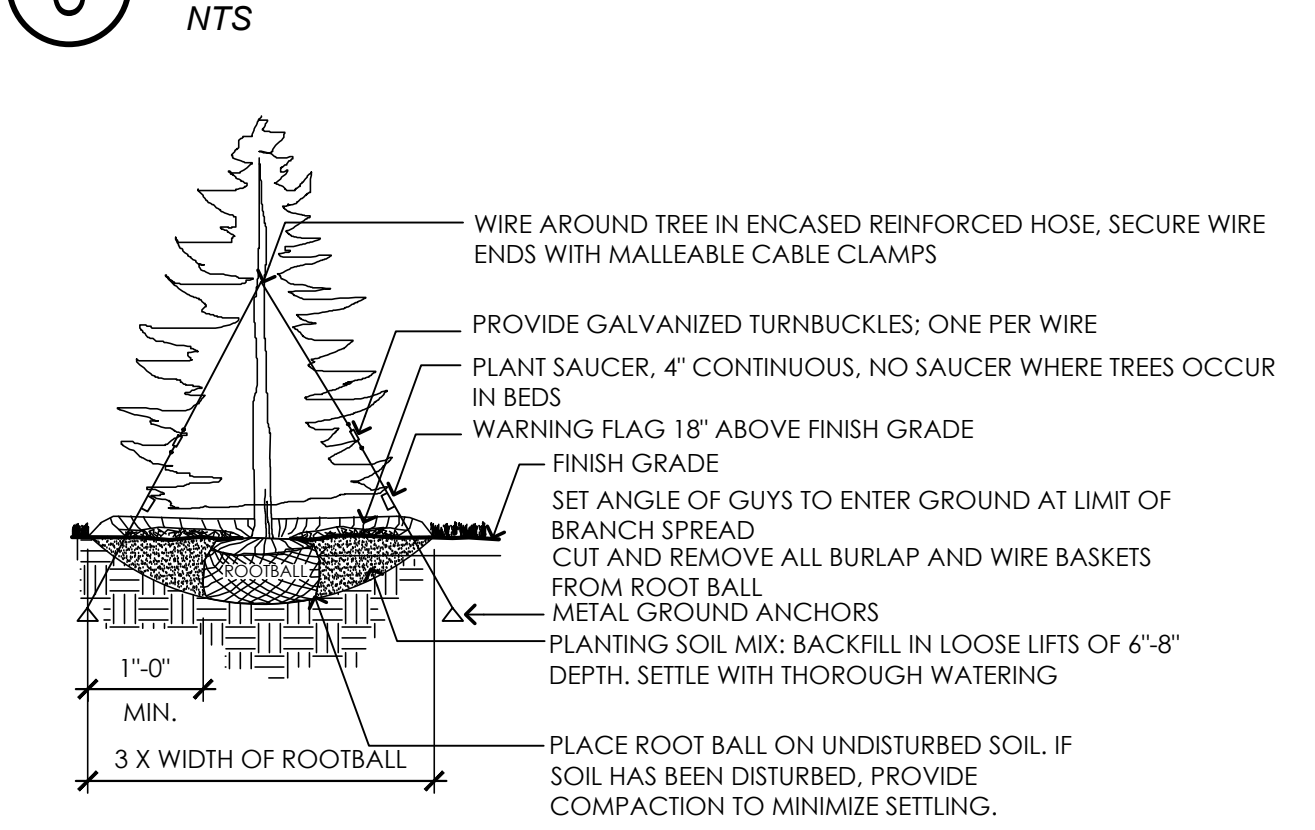

4 TYPICAL EVERGREEN TREE PLANTING
NTS

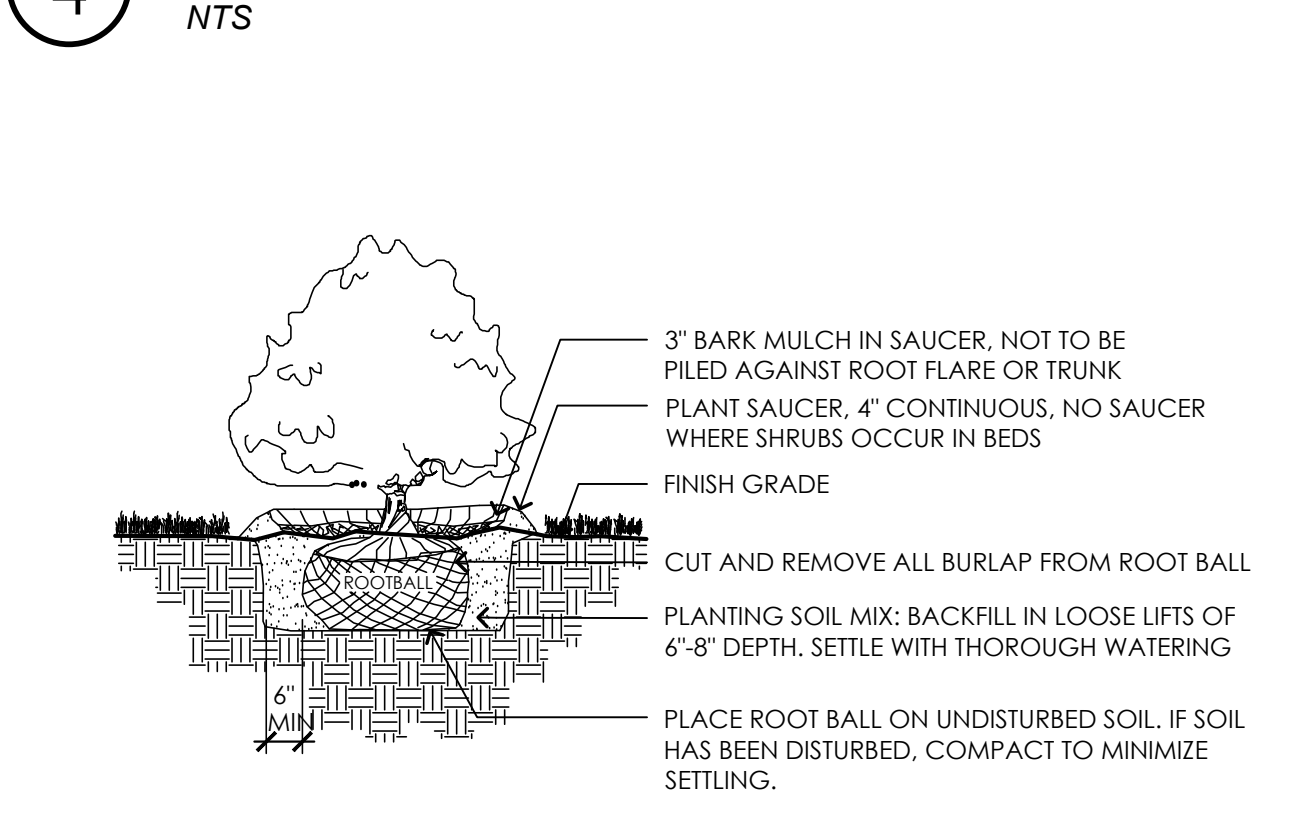

5 TYPICAL SHRUB PLANTING
NTS

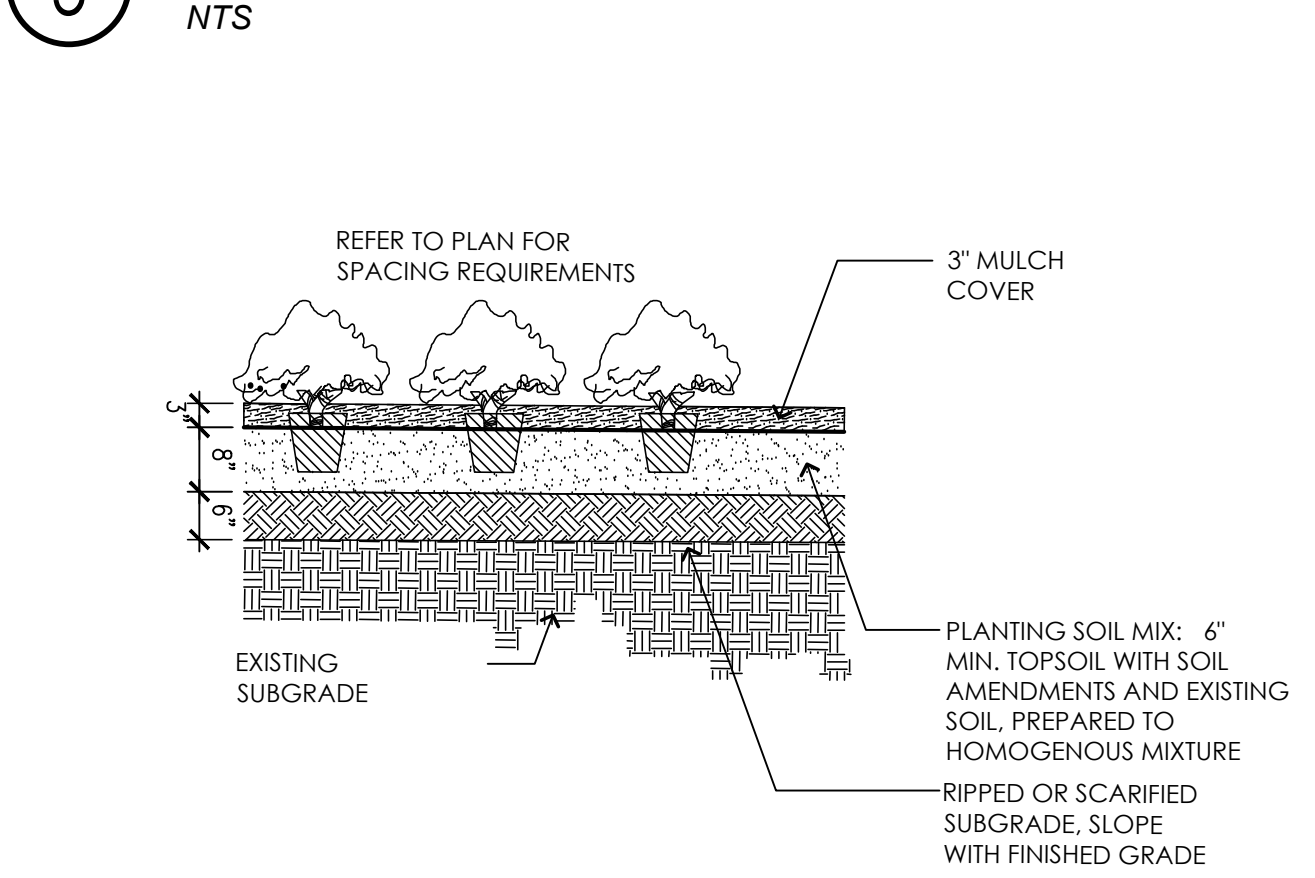

6 TYPICAL GROUNDCOVER PLANTING
NTS

2 MAINTENANCE EDGE
NTS



11/30/2020

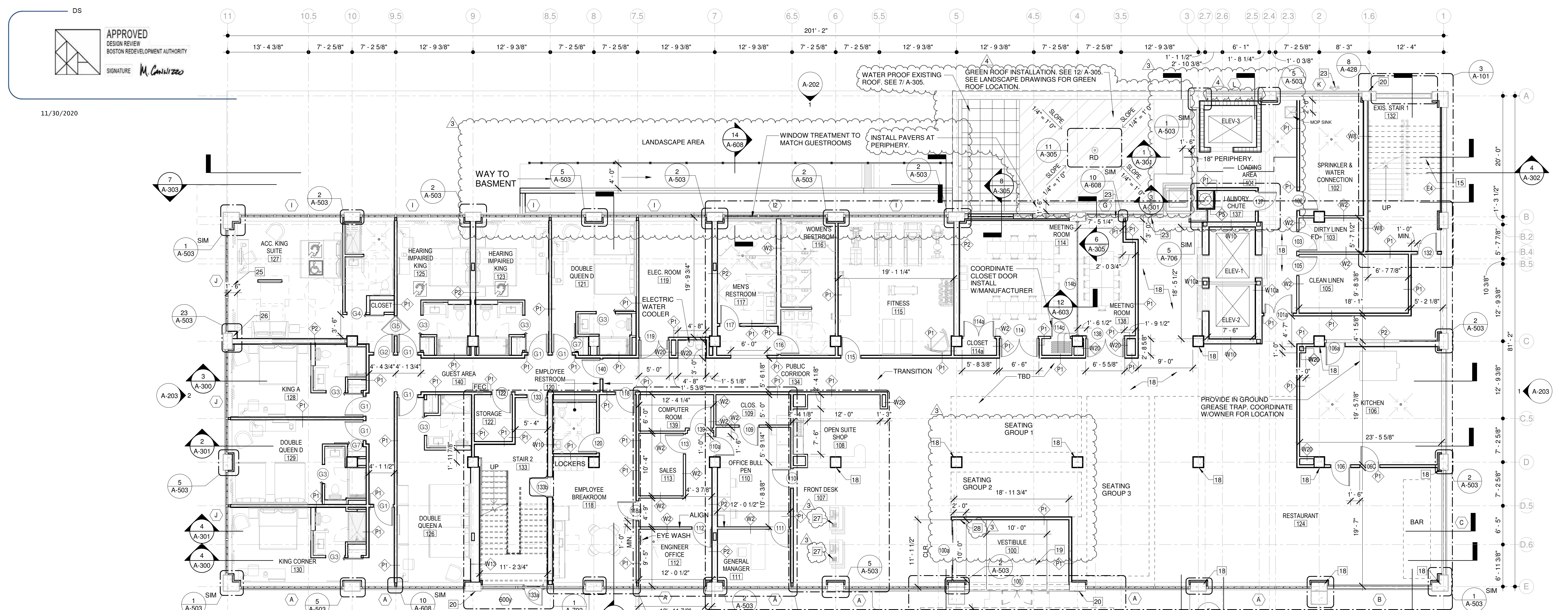

KEY NOTES

- 1 REFER TO ENLARGED PLAN FOR COMMON SPACE FURNITURE REQUIREMENTS AND FINISHES.
- 2 LUGGAGE CART N.I.C.
- 3 REFER TO ENLARGED PLAN FOR FITNESS CENTER EQUIPMENT. PURCHASED BY OWNER INSTALL BY G.C.
- 4 NEW FURNITURE TO BE PROVIDED BY FF&E PROVIDER AND INSTALLED BY G.C.
- 5 ALL RATED ASSEMBLIES TO MEET UL ASSEMBLIES. SEE PENETRATION DETAIL SHEET.
- 6 OWNER TO PROVIDE SIGNAGE PACKAGE PER FRANCHISE STANDARD, G.C. TO INSTALL.
- 7 RECESSED FLOOR MAT. VERIFY DEPT - 91VYM T.M. MANUFACTURER. COORDINATE W/ CONCRETE CONTRACTOR FOR SLAB RECESS.
- 8 CARD READER AND/OR AFTER HOURS INTERCOM MOUNTED 42" A.F.F. - FRONT DOOR & REAR DOOR.
- 9 RATED LINEN CHUTE INTAKE HATCH, SELF-CLOSING.
- 10 EXISTING OPENING AT STAIRCASE TO BE CLOSED.
- 11 NEW DOOR OPENING IN EXISTING BASEMENT WALL.
- 12 NEW CONCRETE PAVERS AT ROOF PATIO SEE BUILDING SECTIONS.
- 13 NOT USED.
- 14 PROVIDE WATER PROOFING @ BASEMENT WALLS
- 15 REMOVE EXISTING SPRINKLER PIPING AND RELOCATE TO BASEMENT. CLEAN AND MATCH FINISHES PER FINISH SCHEDULE.
- 16 NEW RAMP TO BASEMENT. SEE SITE AND STRUCTURAL DRAWINGS.
- 17 SEAL EXISTING STAIR TO BASEMENT. SEE STRUCTURAL DRAWINGS.
- 18 EXPOSED CONCRETE FINISH.
- 19 SURFACE WALK-OFF FLOOR MAT QUIET FLEX LOW DENSITY POLYETHYLENE MAT WITH FRAME TYPE 5 AND HINGE MAT MODEL M-650U ULTRASORB BY ARDEN ARCHITECTURAL SPECIALTIES INC. OR APPROVED EQUAL. MAT TO BE MAINTAINED ONCE A WEEK.
- 20 PROVIDE SIGN TYPE 'A' SEE A400a FOR DETAILS.
- 21 REPLACE EXISTING ROOF DRAINS PER NEW ROOF PLAN.
- 22 NEW EPDM ROOF MAINTAIN EXISTING ROOF SLOPES.
- 23 PATCH EXISTING WALL OPENING WITH WALL FLUS WALL ON MEETING ROOM SIDE.
- 24 FIRE DEPARTMENT CONNECTION COORDINATE W/FIRE DEPARTMENT FOR APPROVED LOCATION.

- 25 PROVIDE 18" DEEP WINDOW SILL ENCLOSURE FOR ACCOMMODATING OVERFLOW DRAIN PIPE.
- 26 ENLARGE COLUMN ENCLOSURE TO ACCOMMODATE OVERFLOW DRAIN PIPE.
- 27 PROVIDE AI PHONE DAK-25 WITH LEM-1DL SYSTEM AT EACH FRONT DESK WORKING SURFACE.
- 28 CARD READER AND INTERCOM TO BE PROVIDED BY G.C. MOUNTING HEIGHT 42".

GENERAL NOTES

1. INSTALL NEW DIRECTIONAL & ROOM SIGNAGE THROUGHOUT BUILDING. G.C. TO OBTAIN SIGNAGE PACKAGE FROM BRAND AUTHORIZED SUPPLIER & ENSURE SIGNAGE SCHEDULE, DESIGN & ALL REQUIRED ITEMS ARE SUBMITTED TO THE BRAND FOR FRANCHISE REVIEW & APPROVAL. G.C. TO PROVIDE COPY OF SUBMITTALS TO ARCHITECT. REFER TO BRAND STANDARDS & PROPERTY IMPROVEMENT PLAN (PIP) FOR LIST OF APPROVED VENDORS.
2. SEE GUESTROOM PLANS SHEETS A-401 THROUGH A-410
3. SEE PUBLIC AREA ENLARGED PLAN SHEETS A-411 THROUGH A-428 FOR PUBLIC AREA DETAILS
4. REFER TO ENLARGED GUEST ROOM PLANS, ELEVATIONS & FINISH SCHEDULE FOR ROOM FINISHES.
5. FIRE RATED ASSEMBLIES TO MEET UL ASSEMBLIES. SEE PENETRATION DETAIL SHEET.
6. ALL GUESTROOM FLOORS TO HAVE EXPOSED CONCRETE FINISH UNO. GUESTROOM BATHROOMS TO HAVE TILE.
7. CENTER ALL WALLS' CENTER OF MULLIONS AS SHOWN UNLESS OTHERWISE NOTED.
8. BLOCKING SHOULD BE ATLEAST 8" LONGER THAN THE FURNITURE AND SOLIDLY ATTACHED TO THE FRAMING. SEE FURNITURE SIZE TYPES AND EXACT LOCATIONS.
9. BLOCKING AS REQUIRED SHOULD INCLUDE BUT NOT BE LIMITED TO HEADBOARDS, MIRRORS, TELEVISIONS, CABINATRY, GRAB BAR, BORN DOORS, VANITIES, ARTWORK, PLUMBING FIXTURES AND PLUMBING ACCESSORIES.

SYMBOL LEGEND

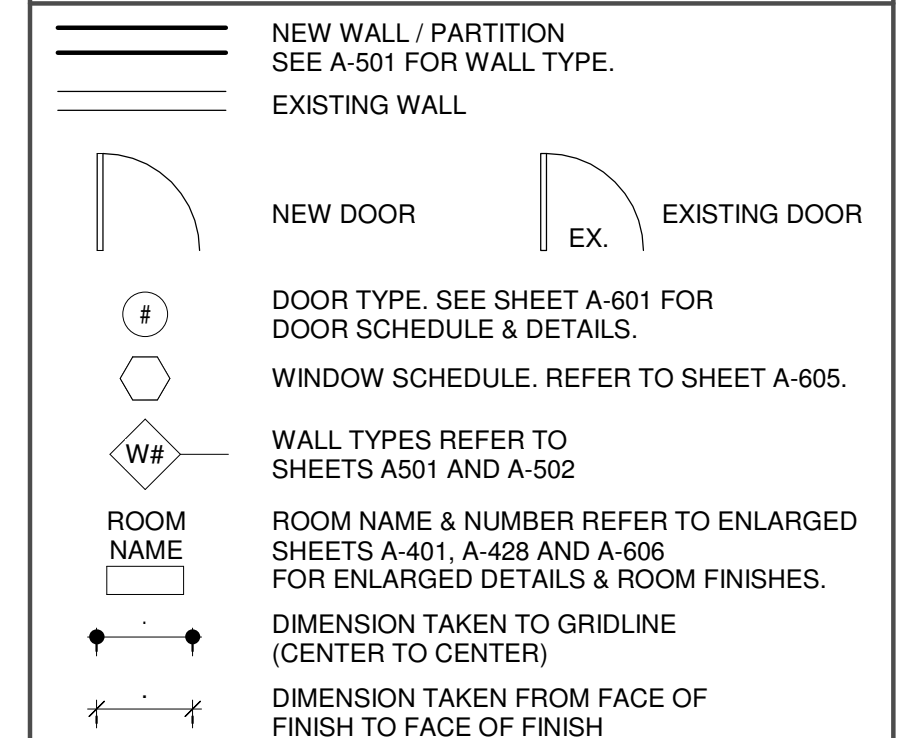

ADA GUESTROOM LEGEND

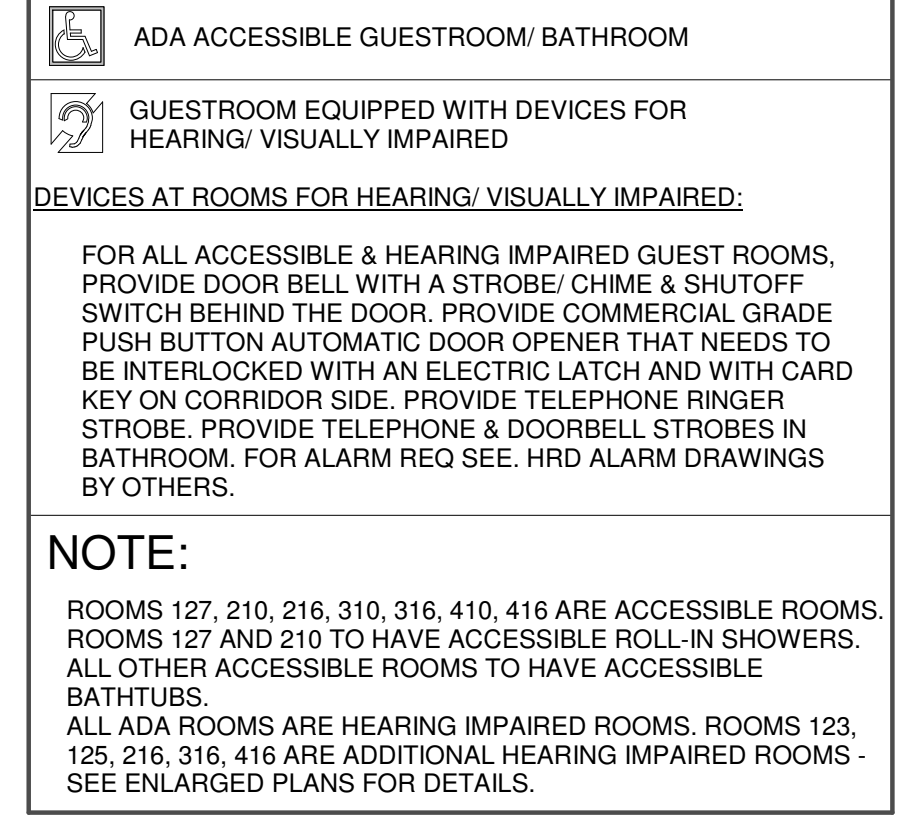

1 FIRST FLOOR PLAN
1/8" = 1'-0"

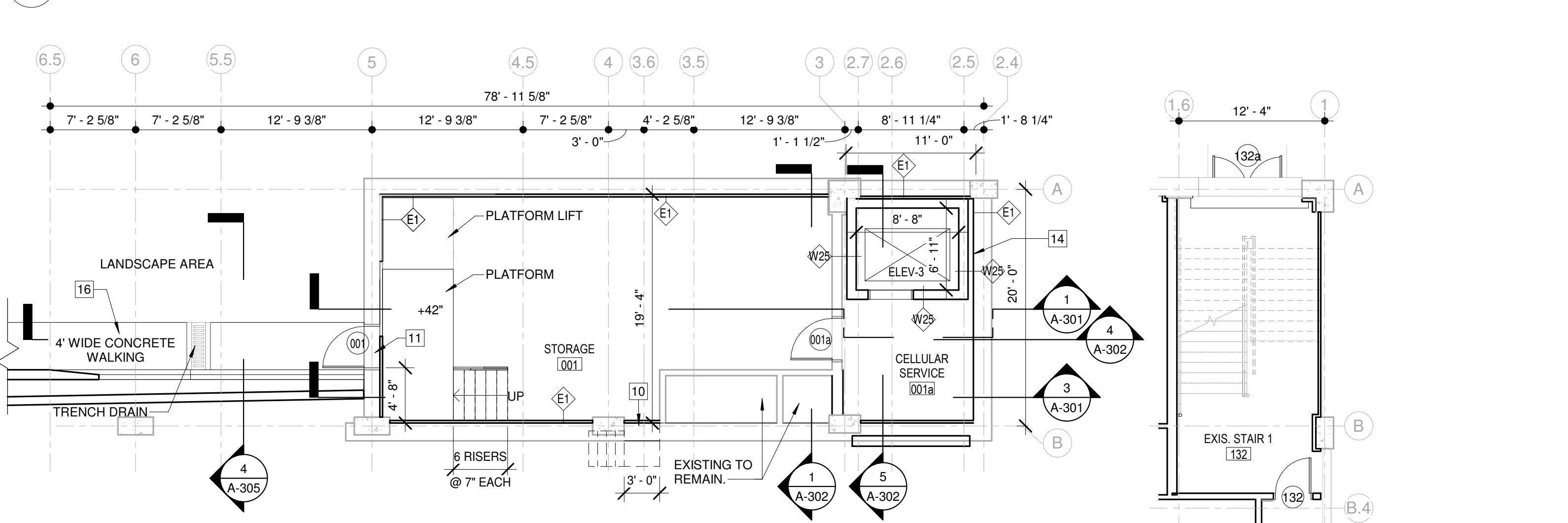

2 BASEMENT FLOOR PLAN
1/8" = 1'-0"

3 PARTIAL FIRST FLOOR LANDING PLAN
1/8" = 1'-0"

RUSSELL AND DAWSON INC.
ARCHITECTURE & ENGINEERING
1111 Main Street, East Hartford, CT 06108
TEL: (860) 282-1100 FAX: (860) 282-5272 EMAIL: info@rdai.com

REVISIONS

NO.	DESCRIPTION	DATE	BY
1	GENERAL REVISION	11/27/2019	UKP
2	PER BPD COMMENTS	01/03/2020	UKP

STAMP:

PROJECT: CONVERSION TO BOSTON HOTEL
175 ORLEANS STREET, BOSTON, MA 02128

FILE NO: 16155.01
SCALE: As indicated
DATE: 08/29/2019
DRAWN BY: AKP
CHECKED BY: UKP

SHEET TITLE: BASEMENT & FIRST FLOOR PLAN
SHEET NUMBER: A-101

APPROVED
DESIGN REVIEW
BOSTON REDEVELOPMENT AUTHORITY
SIGNATURE: M. Cannizzo

11/30/2020

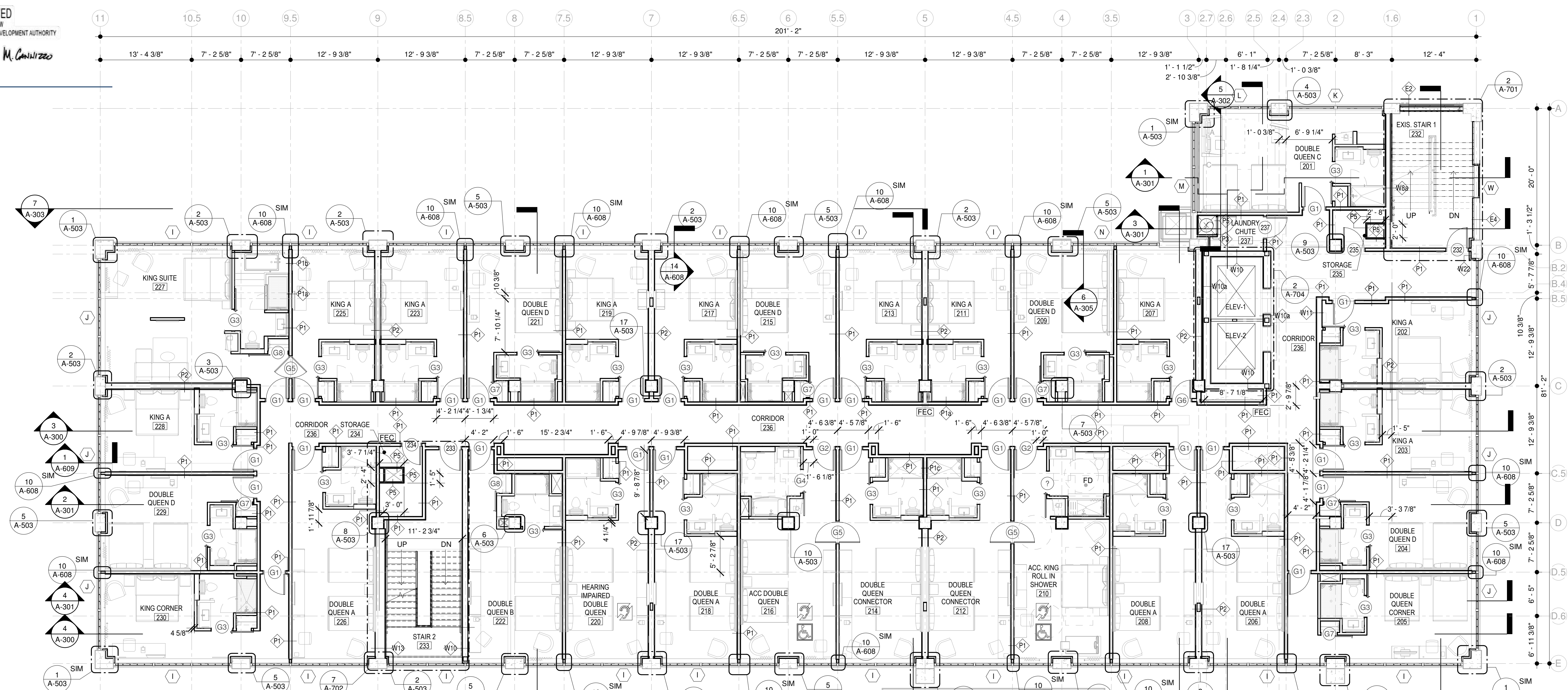

- ### KEY NOTES
- REFER TO ENLARGED PLAN FOR COMMON SPACE FURNITURE REQUIREMENTS AND FINISHES.
 - LUGGAGE CART N.I.C.
 - REFER TO ENLARGED PLAN FOR FITNESS CENTER EQUIPMENT. PURCHASED BY OWNER INSTALL BY G.C.
 - NEW FURNITURE TO BE PROVIDED BY FF&E PROVIDER AND INSTALLED BY G.C.
 - ALL RATED ASSEMBLIES TO MEET UL ASSEMBLIES. SEE PENETRATION DETAIL SHEET.
 - OWNER TO PROVIDE SIGNAGE PACKAGE PER FRANCHISE STANDARD, G.C. TO INSTALL.
 - RECESSED FLOOR MAT- VERIFY DEPT - 91VYM T.M. MANUFACTURER. COORDINATE W/ CONCRETE CONTRACTOR FOR SLAB RECESS.
 - CARD READER AND/OR AFTER HOURS INTERCOM MOUNTED 42" A.F.F. - FRONT DOOR & REAR DOOR.
 - RATED LINEN CHUTE INTAKE HATCH, SELF-CLOSING.
 - EXISTING OPENING AT STAIRCASE TO BE CLOSED.
 - NEW DOOR OPENING IN EXISTING BASEMENT WALL.
 - NEW CONCRETE PAVERS AT ROOF PATIO SEE BUILDING SECTIONS.
 - NOT USED.
 - PROVIDE WATER PROOFING @ BASEMENT WALLS
 - REMOVE EXISTING SPRINKLER PIPING AND RELOCATE TO BASEMENT. CLEAN AND MATCH FINISHES PER FINISH SCHEDULE.
 - NEW RAMP TO BASEMENT. SEE SITE AND STRUCTURAL DRAWINGS.
 - SEAL EXISTING STAIR TO BASEMENT. SEE STRUCTURAL DRAWINGS.
 - EXPOSED CONCRETE FINISH.
 - SURFACE WALK-OFF FLOOR MAT QUIETFLEX LOW DENSITY POLYETHYLENE MAT WITH FRAME TYPE 5 AND HINGE MAT MODEL M-650U, ULTRASORB BY ARDEN ARCHITECTURAL SPECIALTIES INC. OR APPROVED EQUAL. MAT TO BE MAINTAINED ONCE A WEEK.
 - PROVIDE SIGN TYPE 'A' SEE A400a FOR DETAILS.
 - REPLACE EXISTING ROOF DRAINS PER NEW ROOF PLAN.
 - NEW EPDM ROOF MAINTAIN EXISTING ROOF SLOPES.
 - PATCH EXISTING WALL OPENING WITH WALL FLUS WALL ON MEETING ROOM SIDE.
 - FIRE DEPARTMENT CONNECTION COORDINATE W/FIRE DEPARTMENT FOR APPROVED LOCATION.

- PROVIDE 1" DEEP WINDOW SILL ENCLOSURE FOR ACCOMODATING OVERFLOW DRAIN PIPE.
- ENLARGE COLUMN ENCLOSURE TO ACCOMODATE OVERFLOW DRAIN PIPE.
- PROVIDE AI PHONE DAK-25 WITH LEM-1DL SYSTEM AT EACH FRONT DESK WORKING SURFACE.
- CARD READER AND INTERCOM TO BE PROVIDED BY GC. MOUNTING HEIGHT 42".

- ### GENERAL NOTES
- INSTALL NEW DIRECTIONAL & ROOM SIGNAGE THROUGHOUT BUILDING. G.C. TO OBTAIN SIGNAGE PACKAGE FROM BRAND AUTHORIZED SUPPLIER & ENSURE SIGNAGE SCHEDULE, DESIGN & ALL REQUIRED ITEMS ARE SUBMITTED TO THE BRAND FOR FRANCHISE REVIEW & APPROVAL. G.C. TO PROVIDE COPY OF SUBMITTALS TO ARCHITECT. REFER TO BRAND STANDARDS & PROPERTY IMPROVEMENT PLAN (PIP) FOR LIST OF APPROVED VENDORS.
 - SEE GUESTROOM PLANS SHEETS A-401 THROUGH A-410
 - SEE PUBLIC AREA ENLARGED PLAN SHEETS A-411 THROUGH A-428 FOR PUBLIC AREA DETAILS
 - REFER TO ENLARGED GUEST ROOM PLANS, ELEVATIONS & FINISH SCHEDULE FOR ROOM FINISHES.
 - FIRE RATED ASSEMBLIES TO MEET UL ASSEMBLIES. SEE PENETRATION DETAIL SHEET.
 - ALL GUESTROOM FLOORS TO HAVE EXPOSED CONCRETE FINISH U.N.O. GUESTROOM BATHROOMS TO HAVE TILE.
 - CENTER ALL WALLS/ CENTER OF MULLIONS AS SHOWN UNLESS OTHERWISE NOTED.
 - BLOCKING SHOULD BE ATLEAST 6" LONGER THAN THE FURNITURE AND SOLIDLY ATTACHED TO THE FRAMING. SEE FURNITURE SIZE TYPES AND EXACT LOCATIONS.
 - BLOCKING AS REQUIRED SHOULD INCLUDE BUT NOT BE LIMITED TO HEADBOARDS, MIRRORS, TELEVISIONS, CABINATRY, GRAB BAR, BORN DOORS, VANITIES, ARTWORK, PLUMBING FIXTURES AND PLUMBING ACCESSORIES.

1 TYPICAL FLOOR PLAN (2ND, 3RD & 4TH FLOOR)
A-102 1/8" = 1'-0"

ADA GUESTROOM LEGEND

ADA ACCESSIBLE GUESTROOM/ BATHROOM

GUESTROOM EQUIPPED WITH DEVICES FOR HEARING/ VISUALLY IMPAIRED

DEVICES AT ROOMS FOR HEARING/ VISUALLY IMPAIRED:

FOR ALL ACCESSIBLE & HEARING IMPAIRED GUEST ROOMS, PROVIDE DOOR BELL WITH A STROBE/ CHIME & SHUTOFF SWITCH BEHIND THE DOOR. PROVIDE COMMERCIAL GRADE PUSH BUTTON AUTOMATIC DOOR OPENER THAT NEEDS TO BE INTERLOCKED WITH AN ELECTRIC LATCH AND WITH CARD KEY ON CORRIDOR SIDE. PROVIDE TELEPHONE RINGER STROBE. PROVIDE TELEPHONE & DOORBELL STROBES IN BATHROOM. FOR ALARM REQ SEE HRD ALARM DRAWINGS BY OTHERS.

NOTE:
ROOMS 127, 210, 216, 310, 316, 410, 416 ARE ACCESSIBLE ROOMS. ROOMS 127 AND 210 TO HAVE ACCESSIBLE ROLL-IN SHOWERS. ALL OTHER ACCESSIBLE ROOMS TO HAVE ACCESSIBLE BATHTUBS.
ALL ADA ROOMS ARE HEARING IMPAIRED ROOMS. ROOMS 123, 125, 216, 316, 416 ARE ADDITIONAL HEARING IMPAIRED ROOMS - SEE ENLARGED PLANS FOR DETAILS.

SYMBOL LEGEND

NEW WALL / PARTITION
SEE A-501 FOR WALL TYPE.
EXISTING WALL

NEW DOOR
EXISTING DOOR

DOOR TYPE. SEE SHEET A-601 FOR DOOR SCHEDULE & DETAILS.
WINDOW SCHEDULE. REFER TO SHEET A-605.

WALL TYPES REFER TO SHEETS A501 AND A-502

ROOM NAME & NUMBER REFER TO ENLARGED SHEETS A-401, A-428 AND A-606 FOR ENLARGED DETAILS & ROOM FINISHES.

DIMENSION TAKEN TO GRIDLINE (CENTER TO CENTER)

DIMENSION TAKEN FROM FACE OF FINISH TO FACE OF FINISH

FILE NO: 16155.01
SCALE: As indicated
DATE: 08/29/2018
DRAWN BY: AKP
CHECKED BY: UKP

PROJECT: CONVERSION TO BOSTON HOTEL
175 ORLEANS STREET, BOSTON, MA 02128

SHEET TITLE: SECOND FLOOR PLAN
SHEET NUMBER: A-102

NO.	REVISIONS	DATE	DESCRIPTION

THIS DOCUMENT, THE IDEAS, CONCEPTS, DESIGN, SPECIFICATIONS, AND INSTRUMENT OF PROFESSIONAL SERVICE, ARE THE PROPERTY OF RUSSELL AND DAWSON INC. AND SHALL REMAIN THE PROPERTY OF RUSSELL AND DAWSON INC. AND SHALL NOT BE REPRODUCED, COPIED, OR TRANSMITTED IN ANY FORM OR BY ANY MEANS, ELECTRONIC OR MECHANICAL, INCLUDING PHOTOCOPYING, RECORDING, OR BY ANY INFORMATION STORAGE AND RETRIEVAL SYSTEM, WITHOUT THE WRITTEN PERMISSION OF RUSSELL AND DAWSON INC. © 2018 Russell and Dawson Inc.



11/30/2020

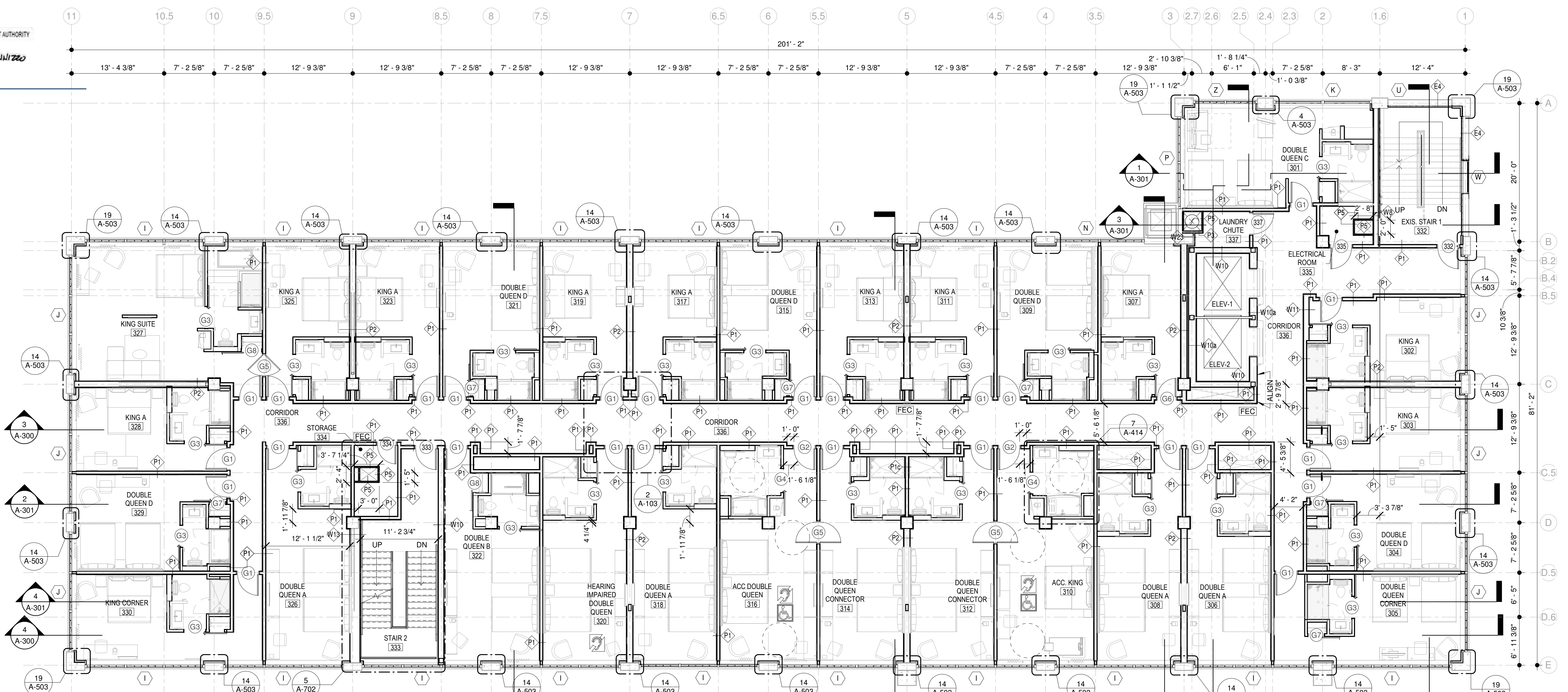

1 THIRD FLOOR PLAN
A-103 1/8" = 1'-0"

KEY NOTES

- 1 REFER TO ENLARGED PLAN FOR COMMON SPACE FURNITURE REQUIREMENTS AND FINISHES.
2 LUGGAGE CART N.I.C.
3 REFER TO ENLARGED PLAN FOR FITNESS CENTER EQUIPMENT. PURCHASED BY OWNER INSTALL BY G.C.
4 NEW FURNITURE TO BE PROVIDED BY FF&E PROVIDER AND INSTALLED BY G.C.
5 ALL RATED ASSEMBLIES TO MEET UL ASSEMBLIES. SEE PENETRATION DETAIL SHEET.
6 OWNER TO PROVIDE SIGNAGE PACKAGE PER FRANCHISE STANDARD, G.C. TO INSTALL.
7 RECESSED FLOOR MAT- VERIFY DEPT - 91VYM T M. MANUFACTURER. COORDINATE W/ CONCRETE CONTRACTOR FOR SLAB RECESS.
8 CARD READER AND/OR AFTER HOURS INTERCOM MOUNTED 42" A.F.F. - FRONT DOOR & REAR DOOR.
9 RATED LINEN CHUTE INTAKE HATCH, SELF-CLOSING.
10 EXISTING OPENING AT STAIRCASE TO BE CLOSED.
11 NEW DOOR OPENING IN EXISTING BASEMENT WALL.
12 NEW CONCRETE PAVERS AT ROOF PATIO SEE BUILDING SECTIONS.
13 NOT USED.
14 PROVIDE WATER PROOFING @ BASEMENT WALLS
15 REMOVE EXISTING SPRINKLER PIPING AND RELOCATE TO BASEMENT. CLEAN AND MATCH FINISHES PER FINISH SCHEDULE.
16 NEW RAMP TO BASEMENT. SEE SITE AND STRUCTURAL DRAWINGS.
17 SEAL EXISTING STAIR TO BASEMENT. SEE STRUCTURAL DRAWINGS.
18 EXPOSED CONCRETE FINISH.
19 SURFACE WALK-OFF FLOOR MAT QUIETFLEX LOW DENSITY POLYETHYLENE MAT WITH FRAME TYPE 5 AND HINGE MAT MODEL M-650J, ULTRASORB BY ARDEN ARCHITECTURAL SPECIALTIES INC. OR APPROVED EQUAL. MAT TO BE MAINTAINED ONCE A WEEK.
20 PROVIDE SIGN TYPE 'A' SEE A400a FOR DETAILS.
21 REPLACE EXISTING ROOF DRAINS PER NEW ROOF PLAN.
22 NEW EPDM ROOF MAINTAIN EXISTING ROOF SLOPES.
23 PATCH EXISTING WALL OPENING WITH WALL FLUS WALL ON MEETING ROOM SIDE.
24 FIRE DEPARTMENT CONNECTION COORDINATE W/FIRE DEPARTMENT FOR APPROVED LOCATION.

- 25 PROVIDE 18" DEEP WINDOW SILL ENCLOSURE FOR ACCOMMODATING OVERFLOW DRAIN PIPE.
26 ENLARGE COLUMN ENCLOSURE TO ACCOMMODATE OVERFLOW DRAIN PIPE.
27 PROVIDE AI PHONE DAK-25 WITH LEM-1DL SYSTEM AT EACH FRONT DESK WORKING SURFACE.
28 CARD READER AND INTERCOM TO BE PROVIDED BY GC. MOUNTING HEIGHT 42".

GENERAL NOTES

- 1. INSTALL NEW DIRECTIONAL & ROOM SIGNAGE THROUGHOUT BUILDING. G.C. TO OBTAIN SIGNAGE PACKAGE FROM BRAND AUTHORIZED SUPPLIER & ENSURE SIGNAGE SCHEDULE, DESIGN & ALL REQUIRED ITEMS ARE SUBMITTED TO THE BRAND FOR FRANCHISE REVIEW & APPROVAL. G.C. TO PROVIDE COPY OF SUBMITTALS TO ARCHITECT. REFER TO BRAND STANDARDS & PROPERTY IMPROVEMENT PLAN (PIP) FOR LIST OF APPROVED VENDORS.
2. SEE GUESTROOM PLANS SHEETS A-401 THROUGH A-410
3. SEE PUBLIC AREA ENLARGED PLAN SHEETS A-411 THROUGH A-428 FOR PUBLIC AREA DETAILS
4. REFER TO ENLARGED GUEST ROOM PLANS, ELEVATIONS & FINISH SCHEDULE FOR ROOM FINISHES.
5. FIRE RATED ASSEMBLIES TO MEET UL ASSEMBLIES. SEE PENETRATION DETAIL SHEET.
6. ALL GUESTROOM FLOORS TO HAVE EXPOSED CONCRETE FINISH U.N.O. GUESTROOM BATHROOMS TO HAVE TILE.
7. CENTER ALL WALLS/ CENTER OF MULLIONS AS SHOWN UNLESS OTHERWISE NOTED.
8. BLOCKING SHOULD BE ATLEAST 8" LONGER THAN THE FURNITURE AND SOLIDLY ATTACHED TO THE FRAMING. SEE FURNITURE SIZE TYPES AND EXACT LOCATIONS.
9. BLOCKING AS REQUIRED SHOULD INCLUDE BUT NOT BE LIMITED TO: HEADBOARDS, MIRRORS, TELEVISIONS, CABINATRY, GRAB BAR, BORN DOORS, VANITIES, ARTWORK, PLUMBING FIXTURES AND PLUMBING ACCESSORIES.

ADA GUESTROOM LEGEND

- ADA ACCESSIBLE GUESTROOM/ BATHROOM
GUESTROOM EQUIPPED WITH DEVICES FOR HEARING/ VISUALLY IMPAIRED
DEVICES AT ROOMS FOR HEARING/ VISUALLY IMPAIRED:
FOR ALL ACCESSIBLE & HEARING IMPAIRED GUEST ROOMS, PROVIDE DOOR BELL WITH A STROBE/ CHIME & SHUTOFF SWITCH BEHIND THE DOOR. PROVIDE COMMERCIAL GRADE PUSH BUTTON AUTOMATIC DOOR OPENER THAT NEEDS TO BE INTERLOCKED WITH AN ELECTRIC LATCH AND WITH CARD KEY ON CORRIDOR SIDE. PROVIDE TELEPHONE RINGER STROBE. PROVIDE TELEPHONE & DOORBELL STROBES IN BATHROOM. FOR ALARM REQ SEE. HRD ALARM DRAWINGS BY OTHERS.
NOTE:
ROOMS 127, 210, 216, 310, 316, 410, 416 ARE ACCESSIBLE ROOMS. ROOMS 127 AND 210 TO HAVE ACCESSIBLE ROLL-IN SHOWERS. ALL OTHER ACCESSIBLE ROOMS TO HAVE ACCESSIBLE BATHTUBS.
ALL ADA ROOMS ARE HEARING IMPAIRED ROOMS. ROOMS 123, 125, 216, 316, 416 ARE ADDITIONAL HEARING IMPAIRED ROOMS - SEE ENLARGED PLANS FOR DETAILS.

SYMBOL LEGEND

- NEW WALL / PARTITION SEE A-501 FOR WALL TYPE. EXISTING WALL
NEW DOOR EX. EXISTING DOOR
DOOR TYPE. SEE SHEET A-601 FOR DOOR SCHEDULE & DETAILS.
WINDOW SCHEDULE. REFER TO SHEET A-605.
WALL TYPES REFER TO SHEETS A501 AND A-502
ROOM NAME & NUMBER REFER TO ENLARGED SHEETS A-401, A-428 AND A-506 FOR ENLARGED DETAILS & ROOM FINISHES.
DIMENSION TAKEN TO GRIDLINE (CENTER TO CENTER)
DIMENSION TAKEN FROM FACE OF FINISH TO FACE OF FINISH

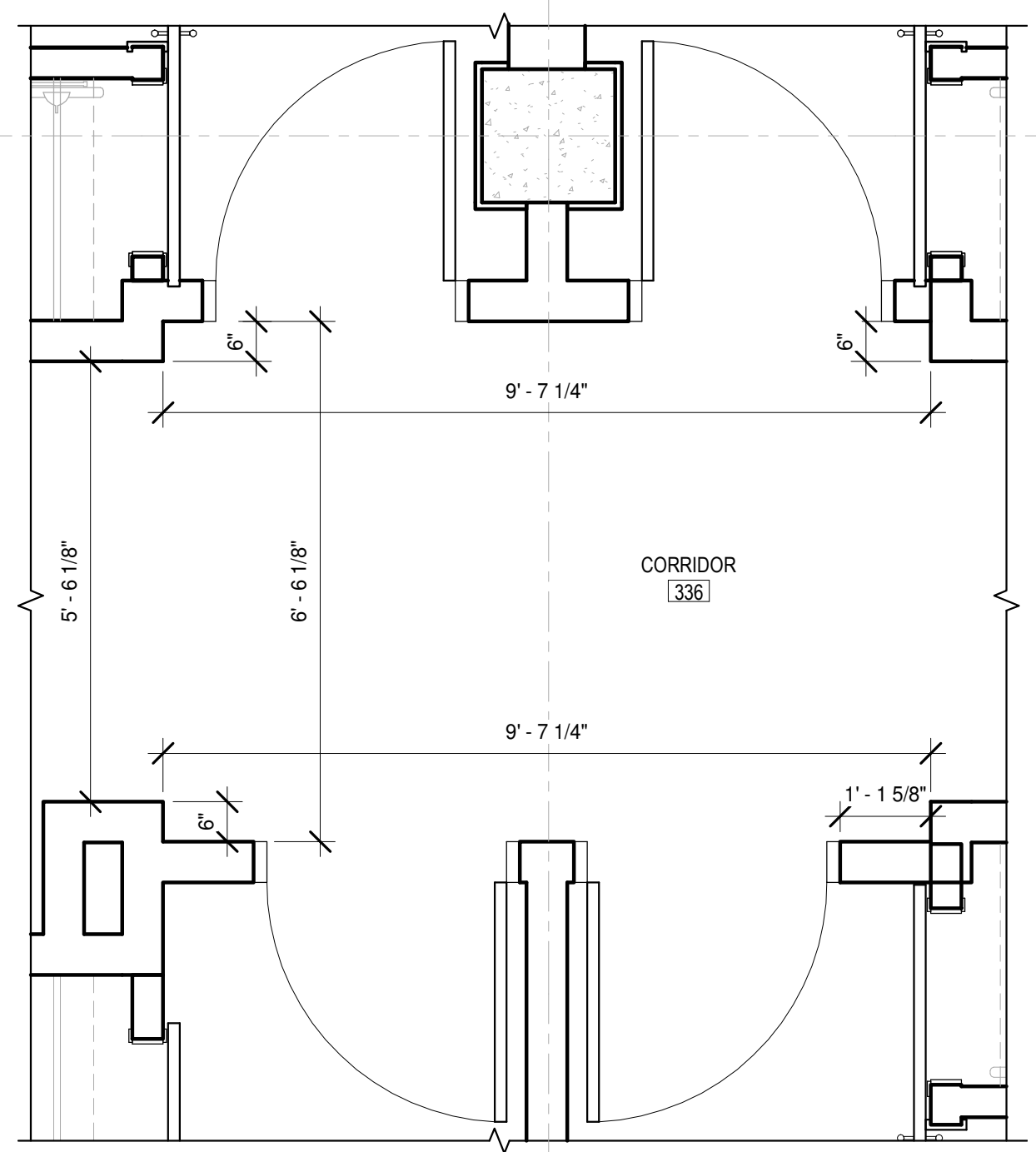

2 ENLARGED GUESTROOM ENTRY
A-103 1/2" = 1'-0"

PROJECT: CONVERSION TO BOSTON HOTEL 175 ORLEANS STREET, BOSTON, MA 02128
SHEET TITLE: THIRD FLOOR PLAN
SHEET NUMBER: A-103
FILE NO: 16155.01
SCALE: As indicated
DATE: 08/29/2018
DRAWN BY: AKP
CHECKED BY: UKP
REVISIONS: NO. DESCRIPTION DATE BY

DS

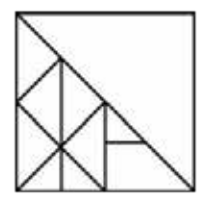

APPROVED DESIGN REVIEW BOSTON REDEVELOPMENT AUTHORITY SIGNATURE M. Cannizzo

11/30/2020

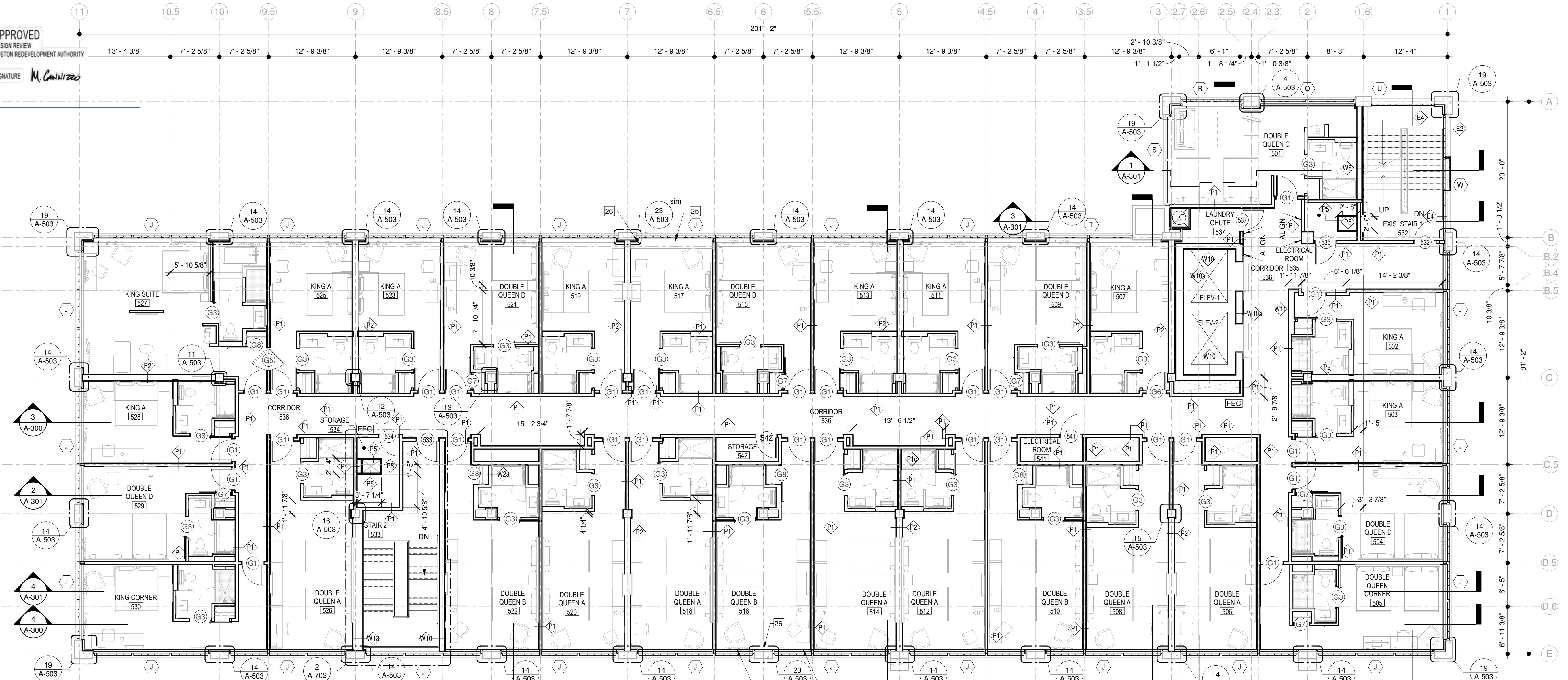

KEY NOTES

- 1 REFER TO ENLARGED PLAN FOR COMMON SPACE FURNITURE REQUIREMENTS AND FINISHES.
2 LUGGAGE CART N.I.C.
3 REFER TO ENLARGED PLAN FOR FITNESS CENTER EQUIPMENT. PURCHASED BY OWNER INSTALL BY G.C.
4 NEW FURNITURE TO BE PROVIDED BY FF&E PROVIDER AND INSTALLED BY G.C.
5 ALL RATED ASSEMBLIES TO MEET UL ASSEMBLIES. SEE PENETRATION DETAIL SHEET.
6 OWNER TO PROVIDE SIGNAGE PACKAGE PER FRANCHISE STANDARD, G.C. TO INSTALL.
7 RECESSED FLOOR MAT- VERIFY DEPT - 91VYM T.M. MANUFACTURER. COORDINATE W/ CONCRETE CONTRACTOR FOR SLAB RECESS.
8 CARD READER AND/OR AFTER HOURS INTERCOM MOUNTED 42" A.F.F. - FRONT DOOR & REAR DOOR.
9 RATED LINEN CHUTE INTAKE HATCH, SELF-CLOSING.
10 EXISTING OPENING AT STAIRCASE TO BE CLOSED.
11 NEW DOOR OPENING IN EXISTING BASEMENT WALL.
12 NEW CONCRETE PAVERS AT ROOF PATIO SEE BUILDING SECTIONS.
13 NOT USED.
14 PROVIDE WATER PROOFING @ BASEMENT WALLS
15 REMOVE EXISTING SPRINKLER PIPING AND RELOCATE TO BASEMENT. CLEAN AND MATCH FINISHES PER FINISH SCHEDULE.
16 NEW RAMP TO BASEMENT. SEE SITE AND STRUCTURAL DRAWINGS.
17 SEAL EXISTING STAIR TO BASEMENT. SEE STRUCTURAL DRAWINGS.
18 EXPOSED CONCRETE FINISH.
19 SURFACE WALK-OFF FLOOR MAT QUIETFLEX LOW DENSITY POLYETHYLENE MAT WITH FRAME TYPE 5 AND HINGE MAT MODEL M-650U, ULTRASORB BY ARDEN ARCHITECTURAL SPECIALTIES INC. OR APPROVED EQUAL. MAT TO BE MAINTAINED ONCE A WEEK.
20 PROVIDE SIGN TYPE 'A' SEE A400a FOR DETAILS.
21 REPLACE EXISTING ROOF DRAINS PER NEW ROOF PLAN.
22 NEW EPDM ROOF MAINTAIN EXISTING ROOF SLOPES.
23 PATCH EXISTING WALL OPENING WITH WALL FLUS WALL ON MEETING ROOM SIDE.
24 FIRE DEPARTMENT CONNECTION COORDINATE W/ FIRE DEPARTMENT FOR APPROVED LOCATION.

- 25 PROVIDE 18" DEEP WINDOW SILL ENCLOSURE FOR ACCOMMODATING OVERFLOW DRAIN PIPE.
26 ENLARGE COLUMN ENCLOSURE TO ACCOMMODATE OVERFLOW DRAIN PIPE.
27 PROVIDE AI PHONE DAK-25 WITH LEM-10L SYSTEM AT EACH FRONT DESK WORKING SURFACE.
28 CARD READER AND INTERCOM TO BE PROVIDED BY GC. MOUNTING HEIGHT 42".

1 FIFTH FLOOR PLAN 1/8" = 1'-0"

GENERAL NOTES

- 1. INSTALL NEW DIRECTIONAL & ROOM SIGNAGE THROUGHOUT BUILDING. G.C. TO OBTAIN SIGNAGE PACKAGE FROM BRAND AUTHORIZED SUPPLIER & ENSURE SIGNAGE SCHEDULE, DESIGN & ALL REQUIRED ITEMS ARE SUBMITTED TO THE BRAND FOR FRANCHISE REVIEW & APPROVAL. G.C. TO PROVIDE COPY OF SUBMITTALS TO ARCHITECT. REFER TO BRAND STANDARDS & PROPERTY IMPROVEMENT PLAN (PIP) FOR LIST OF APPROVED VENDORS.
2. SEE GUESTROOM PLANS SHEETS A-401 THROUGH A-410
3. SEE PUBLIC AREA ENLARGED PLAN SHEETS A-411 THROUGH A-428 FOR PUBLIC AREA DETAILS.
4. REFER TO ENLARGED GUEST ROOM PLANS, ELEVATIONS & FINISH SCHEDULE FOR ROOM FINISHES.
5. FIRE RATED ASSEMBLIES TO MEET UL ASSEMBLIES. SEE PENETRATION DETAIL SHEET.
6. ALL GUESTROOM FLOORS TO HAVE EXPOSED CONCRETE FINISH U.N.O. GUESTROOM BATHROOMS TO HAVE TILE.
7. CENTER ALL WALLS/ CENTER OF MULLIONS AS SHOWN UNLESS OTHERWISE NOTED.
8. BLOCKING SHOULD BE ATLEAST 8" LONGER THAN THE FURNITURE AND SOLIDLY ATTACHED TO THE FRAMING. SEE FURNITURE SIZE TYPES AND EXACT LOCATIONS.
9. BLOCKING AS REQUIRED SHOULD INCLUDE BUT NOT BE LIMITED TO HEADBOARDS, MIRRORS, TELEVISIONS, CABINATRY, GRAB BAR, BORN DOORS, VANITIES, ARTWORK, PLUMBING FIXTURES AND PLUMBING ACCESSORIES.

ADA GUESTROOM LEGEND

- ADA ACCESSIBLE GUESTROOM/ BATHROOM
GUESTROOM EQUIPPED WITH DEVICES FOR HEARING/ VISUALLY IMPAIRED
DEVICES AT ROOMS FOR HEARING/ VISUALLY IMPAIRED:
FOR ALL ACCESSIBLE & HEARING IMPAIRED GUEST ROOMS, PROVIDE DOOR BELL WITH A STROBE/ CHIME & SHUTOFF SWITCH BEHIND THE DOOR. PROVIDE COMMERCIAL GRADE PUSH BUTTON AUTOMATIC DOOR OPENER THAT NEEDS TO BE INTERLOCKED WITH AN ELECTRIC LATCH AND WITH CARD KEY ON CORRIDOR SIDE. PROVIDE TELEPHONE RINGER STROBE. PROVIDE TELEPHONE & DOORBELL STROBES IN BATHROOM. FOR ALARM REQ SEE. HRD ALARM DRAWINGS BY OTHERS.
NOTE:
ROOMS 127, 210, 216, 310, 316, 410, 416 ARE ACCESSIBLE ROOMS. ROOMS 127 AND 210 TO HAVE ACCESSIBLE ROLL-IN SHOWERS. ALL OTHER ACCESSIBLE ROOMS TO HAVE ACCESSIBLE BATHTUBS.
ALL ADA ROOMS ARE HEARING IMPAIRED ROOMS. ROOMS 123, 125, 216, 316, 416 ARE ADDITIONAL HEARING IMPAIRED ROOMS - SEE ENLARGED PLANS FOR DETAILS.

SYMBOL LEGEND

- NEW WALL / PARTITION SEE A-501 FOR WALL TYPE.
EXISTING WALL
NEW DOOR
EXISTING DOOR
DOOR TYPE. SEE SHEET A-601 FOR DOOR SCHEDULE & DETAILS.
WINDOW SCHEDULE. REFER TO SHEET A-605.
WALL TYPES REFER TO SHEETS A501 AND A-502
ROOM NAME & NUMBER REFER TO ENLARGED SHEETS A-401, A-428 AND A-606 FOR ENLARGED DETAILS & ROOM FINISHES.
DIMENSION TAKEN TO GRIDLINE (CENTER TO CENTER)
DIMENSION TAKEN FROM FACE OF FINISH TO FACE OF FINISH

Vertical sidebar containing project information: PROJECT: CONVERSION TO BOSTON HOTEL, SHEET TITLE: FIFTH FLOOR PLAN, SHEET NUMBER: A-105, FILE NO: 16155.01, SCALE: As indicated, DATE: 08/29/2018, DRAWN BY: AKP, CHECKED BY: UKP, and contact information for Russell and Dawson Inc.

C:\Revit\Local\16.155.01_ARCH_CENTRAL_R20_dhammadra.prelipat@rddep.com.rvt 26-11-2019 18:40:04

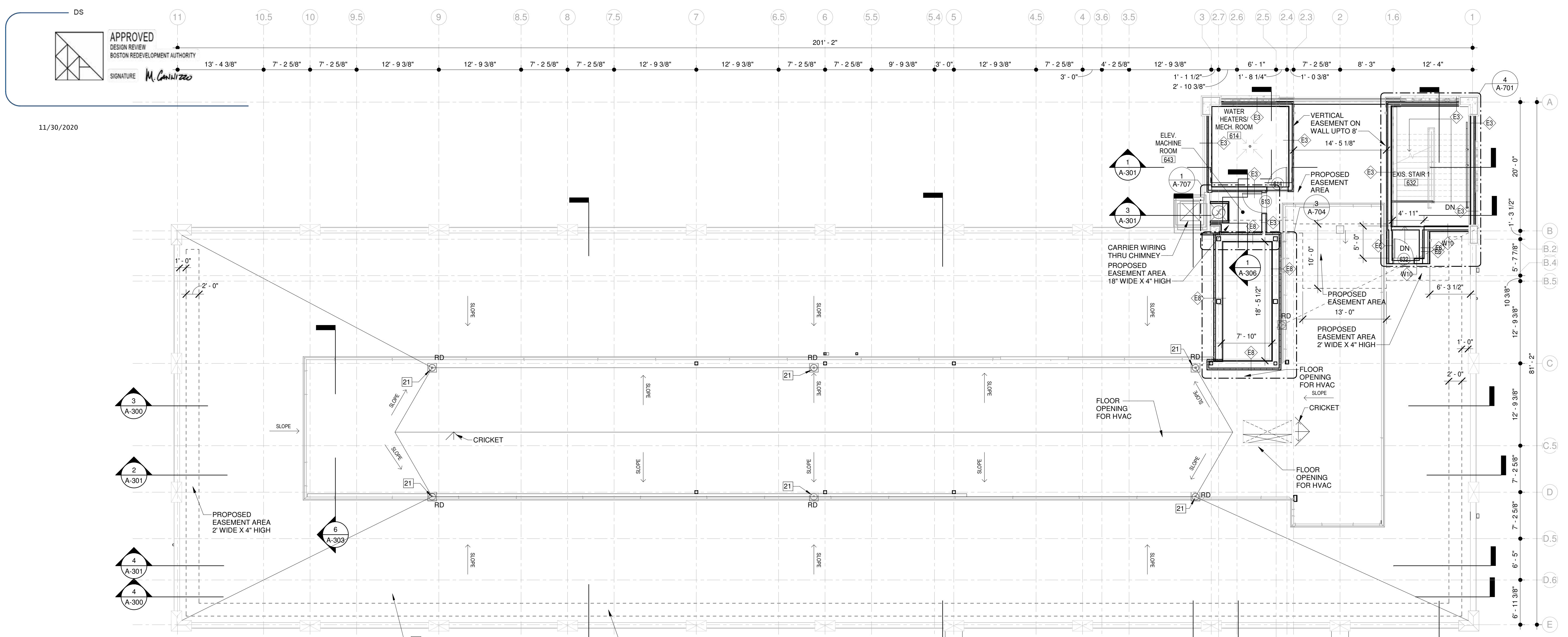

APPROVED
DESIGN REVIEW
BOSTON REDEVELOPMENT AUTHORITY
SIGNATURE *M. Carlucci*

11/30/2020

- ### KEY NOTES
- REFER TO ENLARGED PLAN FOR COMMON SPACE FURNITURE REQUIREMENTS AND FINISHES.
 - LUGGAGE CART N.I.C.
 - REFER TO ENLARGED PLAN FOR FITNESS CENTER EQUIPMENT. PURCHASED BY OWNER INSTALL BY G.C.
 - NEW FURNITURE TO BE PROVIDED BY FF&E PROVIDER AND INSTALLED BY G.C.
 - ALL RATED ASSEMBLIES TO MEET UL ASSEMBLIES. SEE PENETRATION DETAIL SHEET.
 - OWNER TO PROVIDE SIGNAGE PACKAGE PER FRANCHISE STANDARD, G.C. TO INSTALL.
 - RECESSED FLOOR MAT - VERIFY DEPT - 91VYM T M. MANUFACTURER. COORDINATE W/ CONCRETE CONTRACTOR FOR SLAB RECESS.
 - CARD READER AND/OR AFTER HOURS INTERCOM MOUNTED 42" A.F.F. - FRONT DOOR & REAR DOOR.
 - RATED LINEN CHUTE INTAKE HATCH, SELF-CLOSING.
 - EXISTING OPENING AT STAIRCASE TO BE CLOSED.
 - NEW DOOR OPENING IN EXISTING BASEMENT WALL.
 - NEW CONCRETE PAVERS AT ROOF PATIO SEE BUILDING SECTIONS.
 - NOT USED.
 - PROVIDE WATER PROOFING @ BASEMENT WALLS
 - REMOVE EXISTING SPRINKLER PIPING AND RELOCATE TO BASEMENT. CLEAN AND MATCH FINISHES PER FINISH SCHEDULE.
 - NEW RAMP TO BASEMENT. SEE SITE AND STRUCTURAL DRAWINGS.
 - SEAL EXISTING STAIR TO BASEMENT. SEE STRUCTURAL DRAWINGS.
 - EXPOSED CONCRETE FINISH.
 - SURFACE WALK-OFF FLOOR MAT QUIETFLEX LOW DENSITY POLYETHYLENE MAT WITH FRAME TYPE 5 AND HINGE MAT MODEL M-650U. ULTRASORB BY ARDEN ARCHITECTURAL SPECIALTIES INC. OR APPROVED EQUAL. MAT TO BE MAINTAINED ONCE A WEEK.
 - PROVIDE SIGN TYPE 'A' SEE A400a FOR DETAILS.
 - REPLACE EXISTING ROOF DRAINS PER NEW ROOF PLAN.
 - NEW EPDM ROOF MAINTAIN EXISTING ROOF SLOPES.
 - PATCH EXISTING WALL OPENING WITH WALL FLUS WALL ON MEETING ROOM SIDE.
 - FIRE DEPARTMENT CONNECTION COORDINATE W/FIRE DEPARTMENT FOR APPROVED LOCATION.

- PROVIDE 1" DEEP WINDOW SILL ENCLOSURE FOR ACCOMMODATING OVERFLOW DRAIN PIPE.
- ENLARGE COLUMN ENCLOSURE TO ACCOMMODATE OVERFLOW DRAIN PIPE.
- PROVIDE AI PHONE DAK-28 WITH LEM-1DL SYSTEM AT EACH FRONT DESK WORKING SURFACE.
- CARD READER AND INTERCOM TO BE PROVIDED BY GC. MOUNTING HEIGHT 42".

- ### GENERAL NOTES
- INSTALL NEW DIRECTIONAL & ROOM SIGNAGE THROUGHOUT BUILDING. G.C. TO OBTAIN SIGNAGE PACKAGE FROM BRAND AUTHORIZED SUPPLIER & ENSURE SIGNAGE SCHEDULE, DESIGN & ALL REQUIRED ITEMS ARE SUBMITTED TO THE BRAND FOR FRANCHISE REVIEW & APPROVAL. G.C. TO PROVIDE COPY OF SUBMITTALS TO ARCHITECT. REFER TO BRAND STANDARDS & PROPERTY IMPROVEMENT PLAN (PIP) FOR LIST OF APPROVED VENDORS.
 - SEE GUESTROOM PLANS SHEETS A-401 THROUGH A-410
 - SEE PUBLIC AREA ENLARGED PLAN SHEETS A-411 THROUGH A-428 FOR PUBLIC AREA DETAILS
 - REFER TO ENLARGED GUEST ROOM PLANS, ELEVATIONS & FINISH SCHEDULE FOR ROOM FINISHES.
 - FIRE RATED ASSEMBLIES TO MEET UL ASSEMBLIES. SEE PENETRATION DETAIL SHEET.
 - ALL GUESTROOM FLOORS TO HAVE EXPOSED CONCRETE FINISH U.N.O. GUESTROOM BATHROOMS TO HAVE TILE.
 - CENTER ALL WALLS/ CENTER OF MULLIONS AS SHOWN UNLESS OTHERWISE NOTED.
 - BLOCKING SHOULD BE ATLEAST 8" LONGER THAN THE FURNITURE AND SOLIDLY ATTACHED TO THE FRAMING. SEE FURNITURE SIZE TYPES AND EXACT LOCATIONS.
 - BLOCKING AS REQUIRED SHOULD INCLUDE BUT NOT BE LIMITED TO HEADBOARDS, MIRRORS, TELEVISIONS, CABINATRY, GRAB BAR, BORN DOORS, VANITIES, ARTWORK, PLUMBING FIXTURES AND PLUMBING ACCESSORIES.

ADA GUESTROOM LEGEND

ADA ACCESSIBLE GUESTROOM/ BATHROOM

GUESTROOM EQUIPPED WITH DEVICES FOR HEARING/ VISUALLY IMPAIRED

DEVICES AT ROOMS FOR HEARING/ VISUALLY IMPAIRED:

FOR ALL ACCESSIBLE & HEARING IMPAIRED GUEST ROOMS, PROVIDE DOOR BELL WITH A STROBE/ CHIME & SHUTOFF SWITCH BEHIND THE DOOR. PROVIDE COMMERCIAL GRADE PUSH BUTTON AUTOMATIC DOOR OPENER THAT NEEDS TO BE INTERLOCKED WITH AN ELECTRIC LATCH AND WITH CARD KEY ON CORRIDOR SIDE. PROVIDE TELEPHONE RINGER STROBE. PROVIDE TELEPHONE & DOORBELL STROBES IN BATHROOM. FOR ALARM REQ SEE HRD ALARM DRAWINGS BY OTHERS.

NOTE:

ROOMS 127, 210, 216, 310, 316, 410, 416 ARE ACCESSIBLE ROOMS. ROOMS 127 AND 210 TO HAVE ACCESSIBLE ROLL-IN SHOWERS. ALL OTHER ACCESSIBLE ROOMS TO HAVE ACCESSIBLE BATHROOMS.

ALL ADA ROOMS ARE HEARING IMPAIRED ROOMS. ROOMS 123, 125, 216, 316, 416 ARE ADDITIONAL HEARING IMPAIRED ROOMS - SEE ENLARGED PLANS FOR DETAILS.

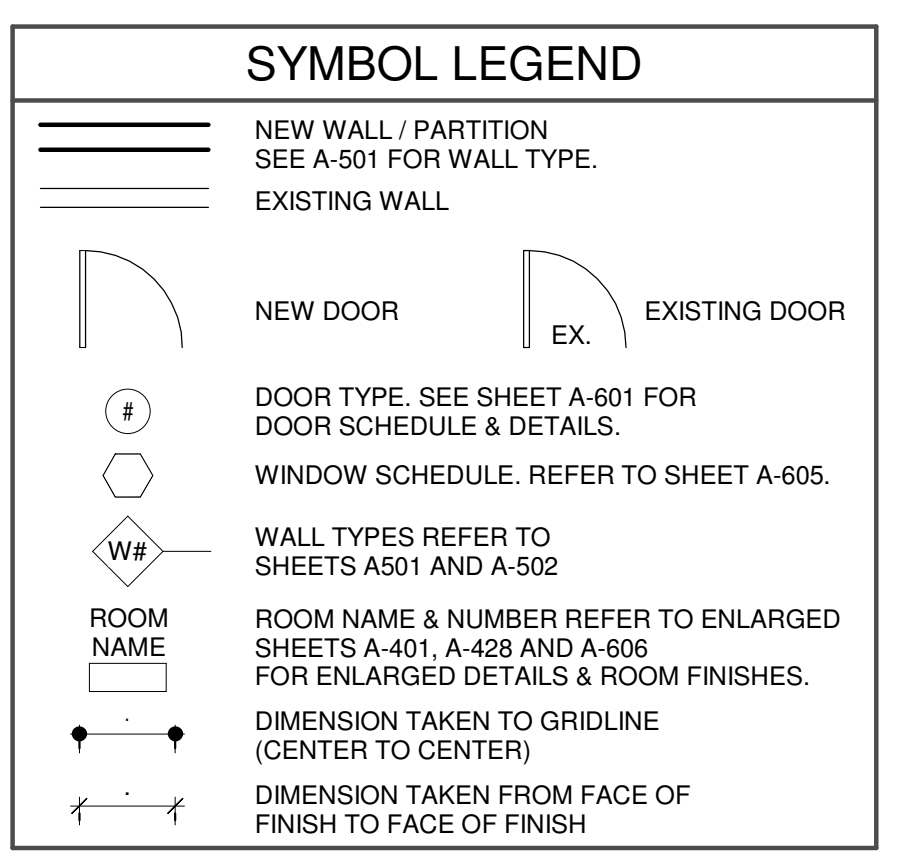

1 SIXTH FLOOR PLAN
A-106 / 1/8" = 1'-0"

FILE NO: 16155.01
SCALE: As indicated
DATE: 08/29/2018
DRAWN BY: AKP
CHECKED BY: UKP

PROJECT: CONVERSION TO BOSTON HOTEL
175 ORLEANS STREET, BOSTON, MA 02128

SHEET TITLE: SIXTH FLOOR PLAN
SHEET NUMBER: A-106

REVISIONS

NO.	DESCRIPTION	DATE	BY

STAMP:

RUSSELL AND DAWSON INC.
ARCHITECTURE & ENGINEERING
1111 Main Street, East Hartford, CT 06108
TEL: (860) 282-1100 FAX: (860) 289-5272 EMAIL: info@rdawson.com

THIS DOCUMENT, THE IDEAS, CONCEPTS, DESIGN, AND INSTRUMENT OF PROFESSIONAL ARCHITECTURE AND ENGINEERING, AND ANY NOT BE USED, REPRODUCED, COPIED, OR TRANSMITTED IN ANY FORM OR BY ANY MEANS, WITHOUT THE WRITTEN PERMISSION OF RUSSELL AND DAWSON INC. OR ANY OTHER PARTY. THE USER SHALL BE SOLELY RESPONSIBLE FOR THE PROTECTION OF THIS DOCUMENT AND THE USER SHALL BE SOLELY RESPONSIBLE FOR THE PROTECTION OF THIS DOCUMENT AND THE USER SHALL BE SOLELY RESPONSIBLE FOR THE PROTECTION OF THIS DOCUMENT.

APPROVED
DESIGN REVIEW
BOSTON REDEVELOPMENT AUTHORITY
SIGNATURE: M. Cannizzo

11/30/2020

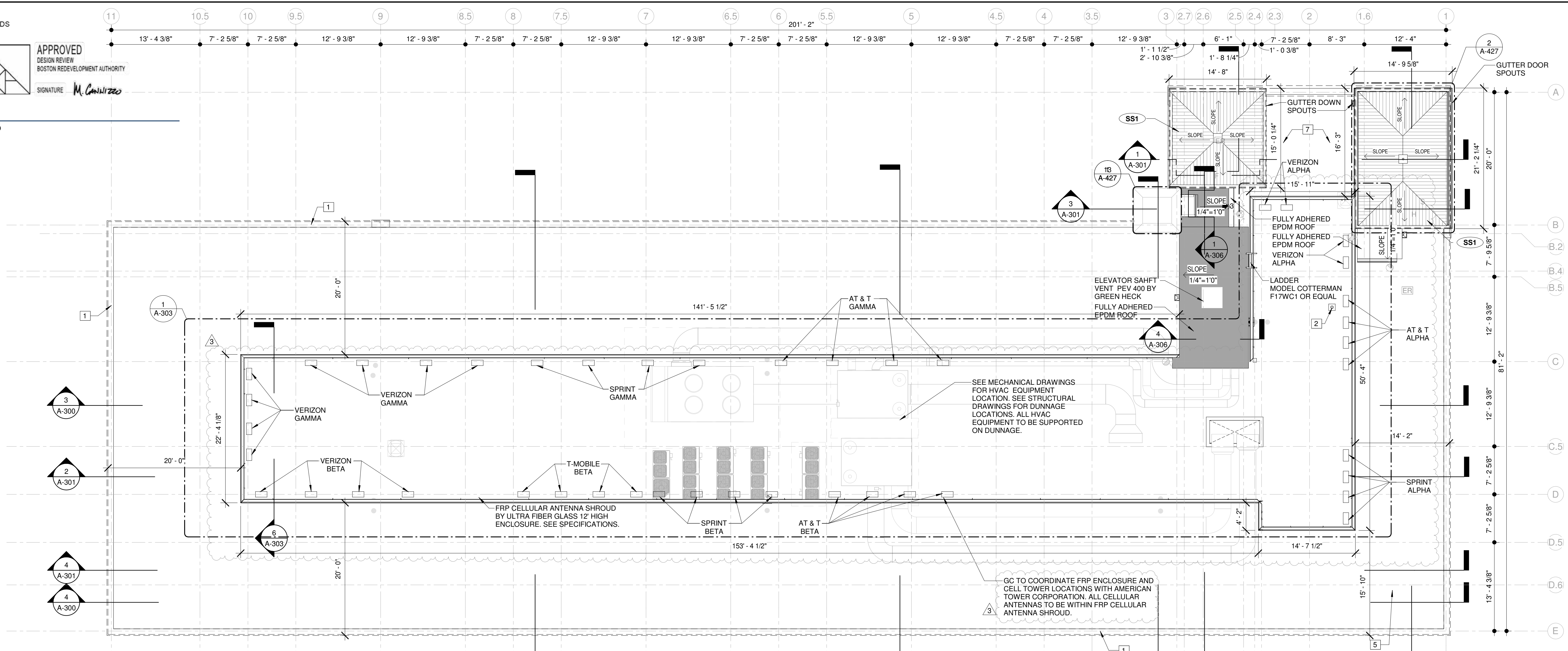

- ### KEY NOTES
- REFER TO ENLARGED PLAN FOR COMMON SPACE FURNITURE REQUIREMENTS AND FINISHES.
 - LUGGAGE CART N.I.C.
 - REFER TO ENLARGED PLAN FOR FITNESS CENTER EQUIPMENT. PURCHASED BY OWNER INSTALL BY G.C.
 - NEW FURNITURE TO BE PROVIDED BY FF&E PROVIDER AND INSTALLED BY G.C.
 - ALL RATED ASSEMBLIES TO MEET UL ASSEMBLIES. SEE PENETRATION DETAIL SHEET.
 - OWNER TO PROVIDE SIGNAGE PACKAGE PER FRANCHISE STANDARD, G.C. TO INSTALL.
 - RECESSED FLOOR MAT- VERIFY DEPT - 91 VV/M T.M. MANUFACTURER. COORDINATE W/ CONCRETE CONTRACTOR FOR SLAB RECESS.
 - CARD READER AND/OR AFTER HOURS INTERCOM MOUNTED 42" A.F.F. - FRONT DOOR & REAR DOOR.
 - RATED LINEN CHUTE INTAKE HATCH, SELF-CLOSING.
 - EXISTING OPENING AT STAIRCASE TO BE CLOSED.
 - NEW DOOR OPENING IN EXISTING BASEMENT WALL.
 - NEW CONCRETE PAVERS AT ROOF PATIO SEE BUILDING SECTIONS.
 - NOT USED.
 - PROVIDE WATER PROOFING @ BASEMENT WALLS
 - REMOVE EXISTING SPRINKLER PIPING AND RELOCATE TO BASEMENT. CLEAN AND MATCH FINISHES PER FINISH SCHEDULE.
 - NEW RAMP TO BASEMENT. SEE SITE AND STRUCTURAL DRAWINGS.
 - SEAL EXISTING STAIR TO BASEMENT. SEE STRUCTURAL DRAWINGS.
 - EXPOSED CONCRETE FINISH.
 - SURFACE WALK-OFF FLOOR MAT QUIETFLEX LOW DENSITY POLYETHYLENE MAT WITH FRAME TYPE 5 AND HINGE MAT MODEL M-650J, ULTRASORB BY ARDEN ARCHITECTURAL SPECIALTIES INC. OR APPROVED EQUAL. MAT TO BE MAINTAINED ONCE A WEEK.
 - PROVIDE SIGN TYPE 'A' SEE A400a FOR DETAILS.
 - REPLACE EXISTING ROOF DRAINS PER NEW ROOF PLAN.
 - NEW EPDM ROOF MAINTAIN EXISTING ROOF SLOPES.
 - PATCH EXISTING WALL OPENING WITH WALL PLUS WALL ON MEETING ROOM SIDE.
 - FIRE DEPARTMENT CONNECTION COORDINATE W/FIRE DEPARTMENT FOR APPROVED LOCATION.

- PROVIDE 1" DEEP WINDOW SILL ENCLOSURE FOR ACCOMMODATING OVERFLOW DRAIN PIPE.
- ENLARGE COLUMN ENCLOSURE TO ACCOMMODATE OVERFLOW DRAIN PIPE.
- PROVIDE AI PHONE DAK-25 WITH LEM-1DL SYSTEM AT EACH FRONT DESK WORKING SURFACE.
- CARD READER AND INTERCOM TO BE PROVIDED BY GC. MOUNTING HEIGHT 42".

- ### GENERAL NOTES
- INSTALL NEW DIRECTIONAL & ROOM SIGNAGE THROUGHOUT BUILDING. G.C. TO OBTAIN SIGNAGE PACKAGE FROM BRAND AUTHORIZED SUPPLIER & ENSURE SIGNAGE SCHEDULE, DESIGN & ALL REQUIRED ITEMS ARE SUBMITTED TO THE BRAND FOR FRANCHISE REVIEW & APPROVAL. G.C. TO PROVIDE COPY OF SUBMITTALS TO ARCHITECT. REFER TO BRAND STANDARDS & PROPERTY IMPROVEMENT PLAN (PIP) FOR LIST OF APPROVED VENDORS.
 - SEE GUESTROOM PLANS SHEETS A-401 THROUGH A-410
 - SEE PUBLIC AREA ENLARGED PLAN SHEETS A-411 THROUGH A-428 FOR PUBLIC AREA DETAILS
 - REFER TO ENLARGED GUEST ROOM PLANS, ELEVATIONS & FINISH SCHEDULE FOR ROOM FINISHES.
 - FIRE RATED ASSEMBLIES TO MEET UL ASSEMBLIES. SEE PENETRATION DETAIL SHEET.
 - ALL GUESTROOM FLOORS TO HAVE EXPOSED CONCRETE FINISH U.N.O. GUESTROOM BATHROOMS TO HAVE TILE.
 - CENTER ALL WALLS/ CENTER OF MULLIONS AS SHOWN UNLESS OTHERWISE NOTED.
 - BLOCKING SHOULD BE AT LEAST 8" LONGER THAN THE FURNITURE AND SOLIDLY ATTACHED TO THE FRAMING. SEE FURNITURE SIZE TYPES AND EXACT LOCATIONS.
 - BLOCKING AS REQUIRED SHOULD INCLUDE BUT NOT BE LIMITED TO HEADBOARDS, MIRRORS, TELEVISIONS, CABINATRY, GRAB BAR, BORN DOORS, VANITIES, ARTWORK, PLUMBING FIXTURES AND PLUMBING ACCESSORIES.

1 ROOF PLAN
A-107
1/8" = 1'-0"

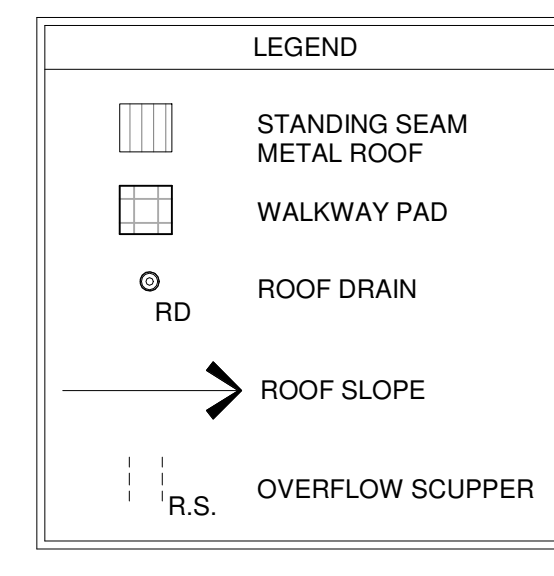
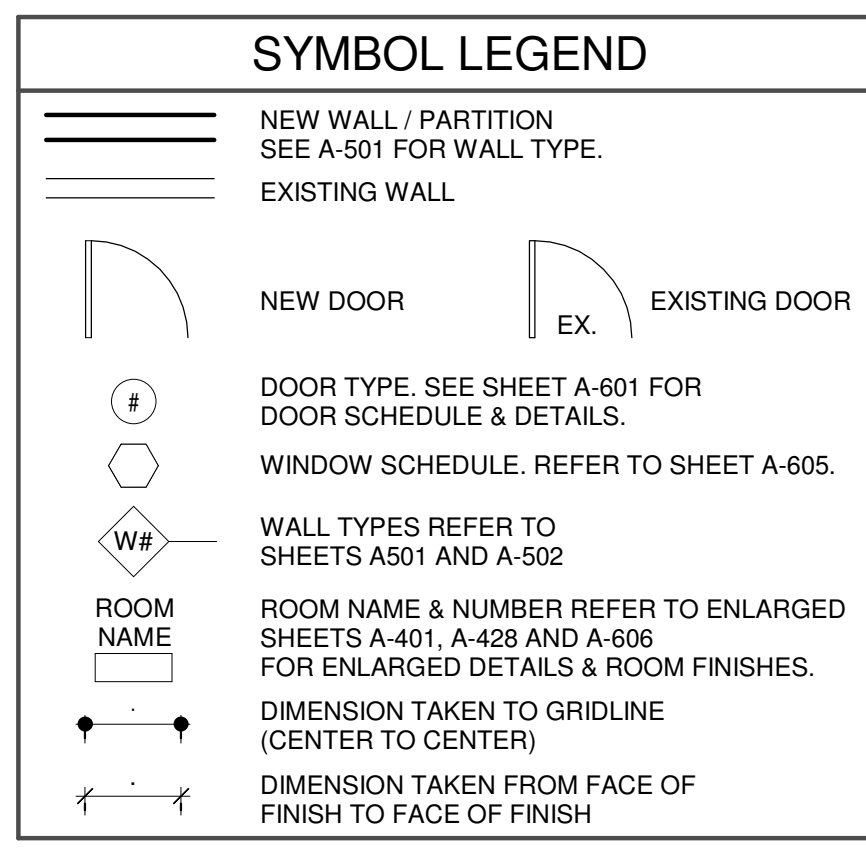

ROOF KEY NOTES

KEY	Label
1	NEW FLASHING AT EXISTING PARAPET WALL
2	ROOF DRAINS.
3	ROOF SCUPPERS
5	PROVIDE VIBRATION REDUCING BASE AT CONDENSOR UNITS.
7	EXISTING CELL-PHONE TOWERS & EQUIPMENT TO BE RELOCATED INSIDE ENCLOSURE. GC TO COORDINATE SCHEDULE WITH OWNER.
21	EXISTING CELL-PHONE TOWERS & EQUIPMENT TO REMAIN. GC TO COORDINATE SCHEDULE WITH OWNER.
22	EXISTING CELL-PHONE TOWERS & EQUIPMENT TO REMAIN. GC TO COORDINATE SCHEDULE WITH OWNER.

FILE NO: 16155.01
SCALE: As indicated
DATE: 08/29/2018
DRAWN BY: AKP
CHECKED BY: UKP

PROJECT: CONVERSION TO BOSTON HOTEL
175 ORLEANS STREET, BOSTON, MA 02128

SHEET TITLE: ROOF PLAN
SHEET NUMBER: A-107

REVISIONS

NO.	DESCRIPTION	DATE	BY
3	GENERAL REVISION	11/27/2019	UKP

THIS DOCUMENT THE IDEAS, CONCEPTS, AND DESIGN OF THE PROJECT ARE THE PROPERTY OF RUSSELL AND DAWSON INC. AND SHALL REMAIN THE PROPERTY OF RUSSELL AND DAWSON INC. AND SHALL NOT BE REPRODUCED, COPIED, OR TRANSMITTED IN ANY FORM OR BY ANY MEANS, ELECTRONIC OR MECHANICAL, INCLUDING PHOTOCOPYING, RECORDING, OR BY ANY INFORMATION STORAGE AND RETRIEVAL SYSTEM, WITHOUT THE WRITTEN PERMISSION OF RUSSELL AND DAWSON INC. © 2019 by Russell and Dawson Inc.

C:\Revit\Local\16.155.01_ARCH_CENTRAL_R20_dhammadra.prajapati@rddep.com.rvt



11/30/2020

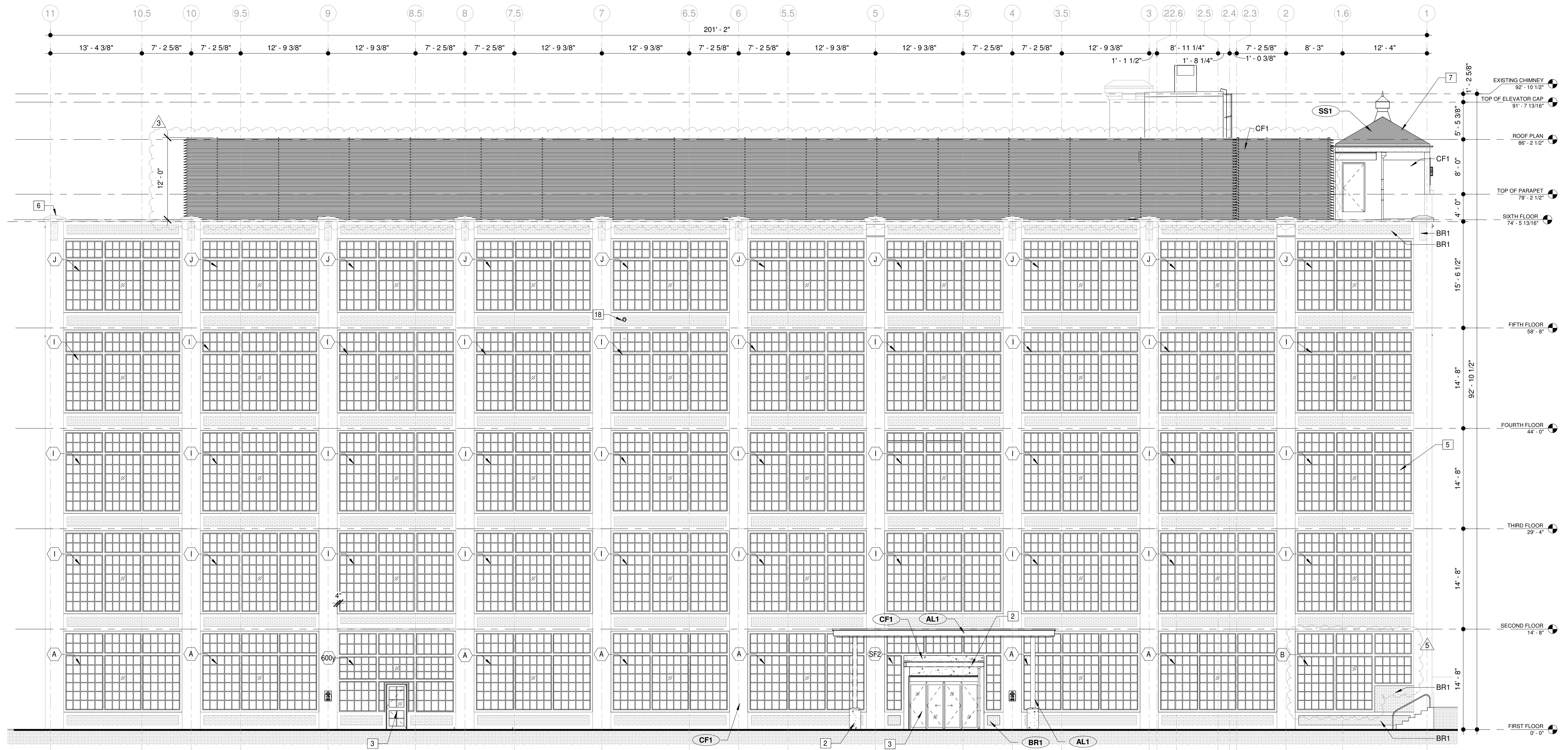

1 REAR ELEVATION
A-201 1/8" = 1'-0"

EXTERIOR KEY NOTES	
KEY	DESCRIPTION
2	NEW PORTE COCHERE AND CANOPY ADDITION
3	NEW DOOR IN EXISTING WALL
4	INFILL WALL TO CREATE WINDOW SILL
5	NEW WINDOWS AT EXISTING OPENINGS (TYP.)
6	NEW FLASHING AT EXISTING COPING (TYP)
7	NEW ROOF AT TOWERS
8	NEW STEEL DOOR OVER INFILL WALL.
9	INFILL EXISTING DOOR OPENING WALL. SEE WALL TYPES.
10	NEW STEEL RAILING WITH PAINT TO MATCH CF1 FINISH, SEE SITE DRAWINGS FOR DETAILS
11	PORTION OF WINDOW TO BE TEMPERED GLASS
12	HVAC EQUIPMENT SCREEN.
13	STEEL ROOF LADDER.
14	ELEVATOR VENT
15	LAUNDRY SHAFT VENT.
16	DECORATIVE ROOF VENTS.
17	REFINISH (PARGE) ALL EXISTING EXT. CONCRETE SURFACES
18	OVERFLOW OUTLET SEE PLUMBING DRAWINGS

GENERAL NOTE

- REFER TO SPECIFICATIONS FOR ALL EXTERIOR REPAIRS AT BRICK AND CONCRETE SURFACES.
- EXISTING BUILDING HAS BEEN PARGED AT 2 SIDES G.C. TO VERIFY EXACT EXTENT OF PARGING REQUIRED.
- EXISTING CHIMNEY TO BE REPAIRED USING REPAIR SPECIFICATIONS.
- RESURFACE EXISTING LOADING DOCK PLATFORM.

EXTERIOR FINISH KEY				
MARK	LOCATION	MANUFACTURER	DISCRIPTION	COMMENTS
AL1	PORTE COCHERE	ALUCOBOND	ALUCOBOND CLADDING, COLOR: BLACK	
BR1	WINDOW SILL INSETS	MACK BRICK	COLOR MATCH EXISTING BRICK FINISH.	
CF1		STO	COLOR MATCH EXISTING CONCRETE PARGED FINISH. STO GRANITEX.	
SS1	HIP ROOFS	BERRIDGE	STANDING SEAM METAL ROOF COLOR : AGED BRONZE	

FILE NO: 16155.01
SCALE: As indicated
DATE: 08/29/2018
DRAWN BY: AKP
CHECKED BY: UKP

PROJECT: CONVERSION TO BOSTON HOTEL
 175 ORLEANS STREET, BOSTON, MA 02128

SHEET TITLE: BUILDING ELEVATION - REAR
SHEET NUMBER: A-201

REVISIONS	
NO.	DESCRIPTION
3	GENERAL REVISION
5	GENERAL REVISION

DATE: 11/27/2019
DATE: 01/13/2020

BY: UKP
BY: UKP

THIS DOCUMENT, THE IDEAS, THE DESIGN, THE DRAWINGS, AND ALL INFORMATION CONTAINED HEREIN ARE THE PROPERTY OF RUSSELL AND DAWSON INC. AND ARE NOT TO BE REPRODUCED, COPIED, OR TRANSMITTED IN ANY FORM OR BY ANY MEANS, ELECTRONIC OR MECHANICAL, INCLUDING PHOTOCOPYING, RECORDING, OR BY ANY INFORMATION STORAGE AND RETRIEVAL SYSTEM. WITHOUT THE WRITTEN PERMISSION OF RUSSELL AND DAWSON INC. THIS DOCUMENT IS TO BE USED ONLY FOR THE PROJECT AND SITE SPECIFICALLY IDENTIFIED HEREIN. © 2019 by Russell and Dawson Inc.

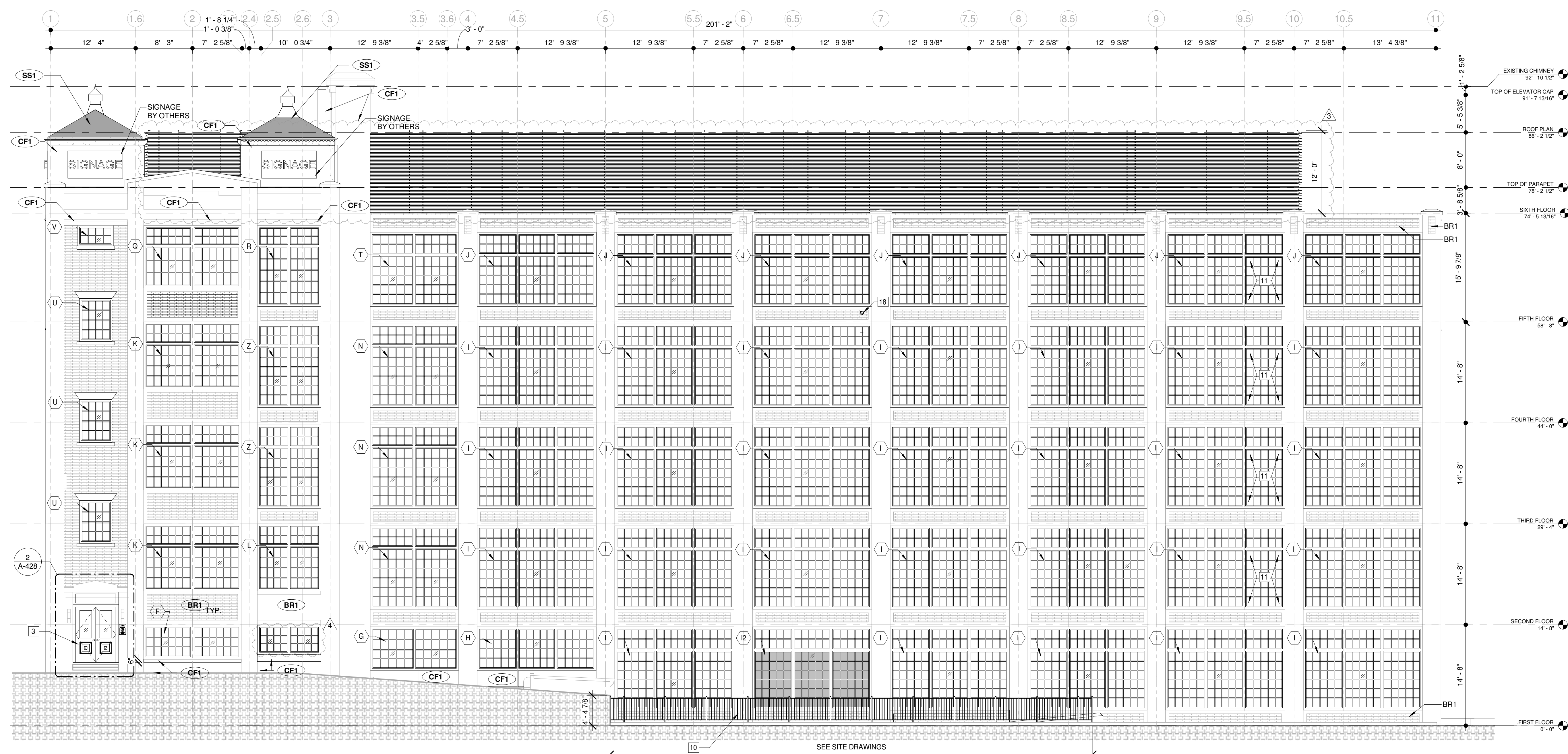

1 FRONT ELEVATION
A-202 1/8" = 1'-0"

APPROVED
DESIGN REVIEW
BOSTON REDEVELOPMENT AUTHORITY
SIGNATURE *M. Canino*

11/30/2020

EXTERIOR KEY NOTES	
KEY	DESCRIPTION
2	NEW PORTE COCHERE AND CANOPY ADDITION
3	NEW DOOR IN EXISTING WALL
4	INFILL WALL TO CREATE WINDOW SILL
5	NEW WINDOWS AT EXISTING OPENINGS (TYP.)
6	NEW FLASHING AT EXISTING COPING (TYP.)
7	NEW ROOF AT TOWERS
8	NEW STEEL DOOR OVER INFILL WALL
9	INFILL EXISTING DOOR OPENING WALL. SEE WALL TYPES.
10	NEW STEEL RAILING WITH PAINT TO MATCH CF1 FINISH. SEE SITE DRAWINGS FOR DETAILS
11	PORTION OF WINDOW TO BE TEMPERED GLASS
12	HVAC EQUIPMENT SCREEN.
13	STEEL ROOF LADDER.
14	ELEVATOR VENT
15	LAUNDRY SHAFT VENT.
16	DECORATIVE ROOF VENTS.
17	REFINISH (PARGE) ALL EXISTING EXT. CONCRETE SURFACES
18	OVERFLOW OUTLET SEE PLUMBING DRAWINGS

GENERAL NOTE	
1.	REFER TO SHEET A-201 FOR EXTERIOR FINISH SCHEDULE.
2.	REFER TO SHEET A-201 FOR LEGEND AND GENERAL NOTES.

PROJECT: CONVERSION TO BOSTON HOTEL
175 ORLEANS STREET, BOSTON, MA 02128

FILE NO: 16155.01
SCALE: As indicated
DATE: 08/29/2018
DRAWN BY: AKP
CHECKED BY: UKP

SHEET TITLE: BUILDING ELEVATION - FRONT
SHEET NUMBER: A-202

NO.	DESCRIPTION	DATE	BY
3	GENERAL REVISION	11/27/2019	UKP
4	PER BPCA COMMENTS	01/03/2020	UKP

REVISIONS

STAMP:

RUSSELL AND DAWSON INC.
ARCHITECTURE & ENGINEERING
1111 Main Street, East Hartford, CT 06108
TEL: (860) 282-1100 FAX: (860) 289-5272 E-MAIL: rdd@russellanddawson.com

THIS DOCUMENT, THE IDEAS, CONCEPTS, DESIGN, DRAWINGS, AND INFORMATION CONTAINED HEREIN ARE THE PROPERTY OF RUSSELL AND DAWSON INC. AND ARE NOT TO BE REPRODUCED, COPIED, OR TRANSMITTED IN ANY FORM OR BY ANY MEANS, ELECTRONIC OR MECHANICAL, INCLUDING PHOTOCOPYING, RECORDING, OR BY ANY INFORMATION STORAGE AND RETRIEVAL SYSTEM, WITHOUT THE WRITTEN PERMISSION OF RUSSELL AND DAWSON INC. © 2019 by Russell and Dawson Inc.

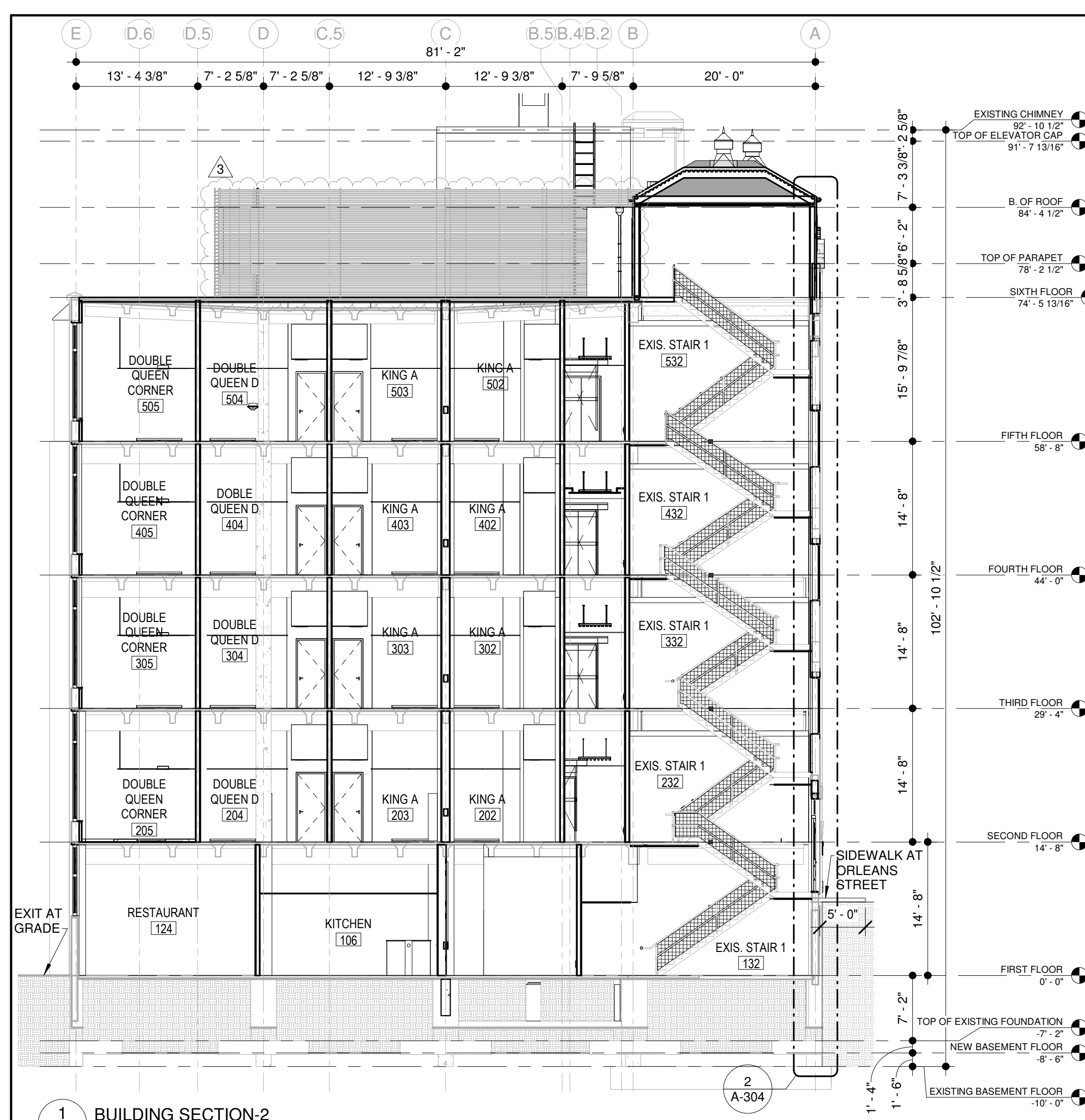

1 BUILDING SECTION-2
A-300 3/32" = 1'-0"

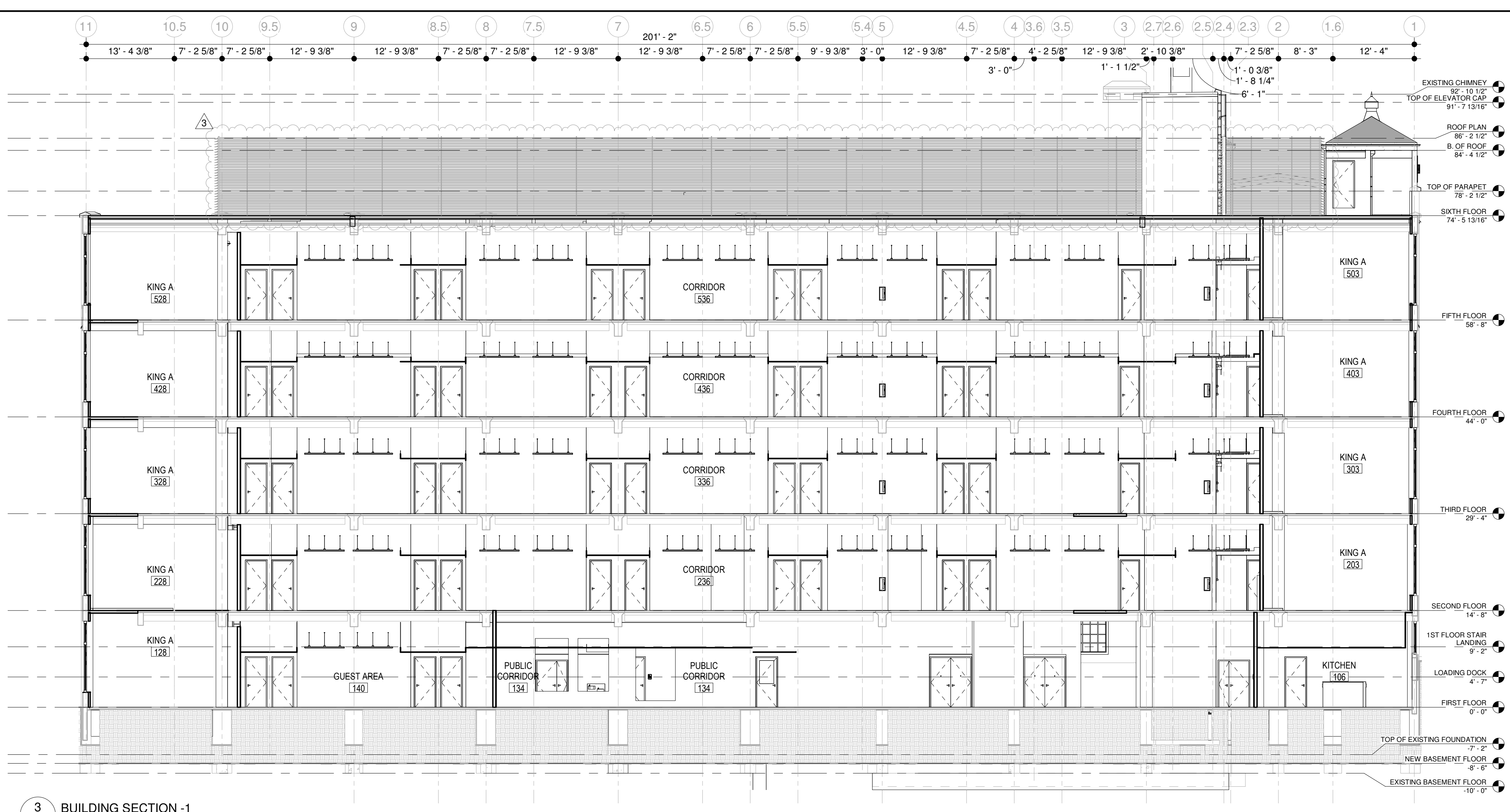

3 BUILDING SECTION -1
A-300 3/32" = 1'-0"

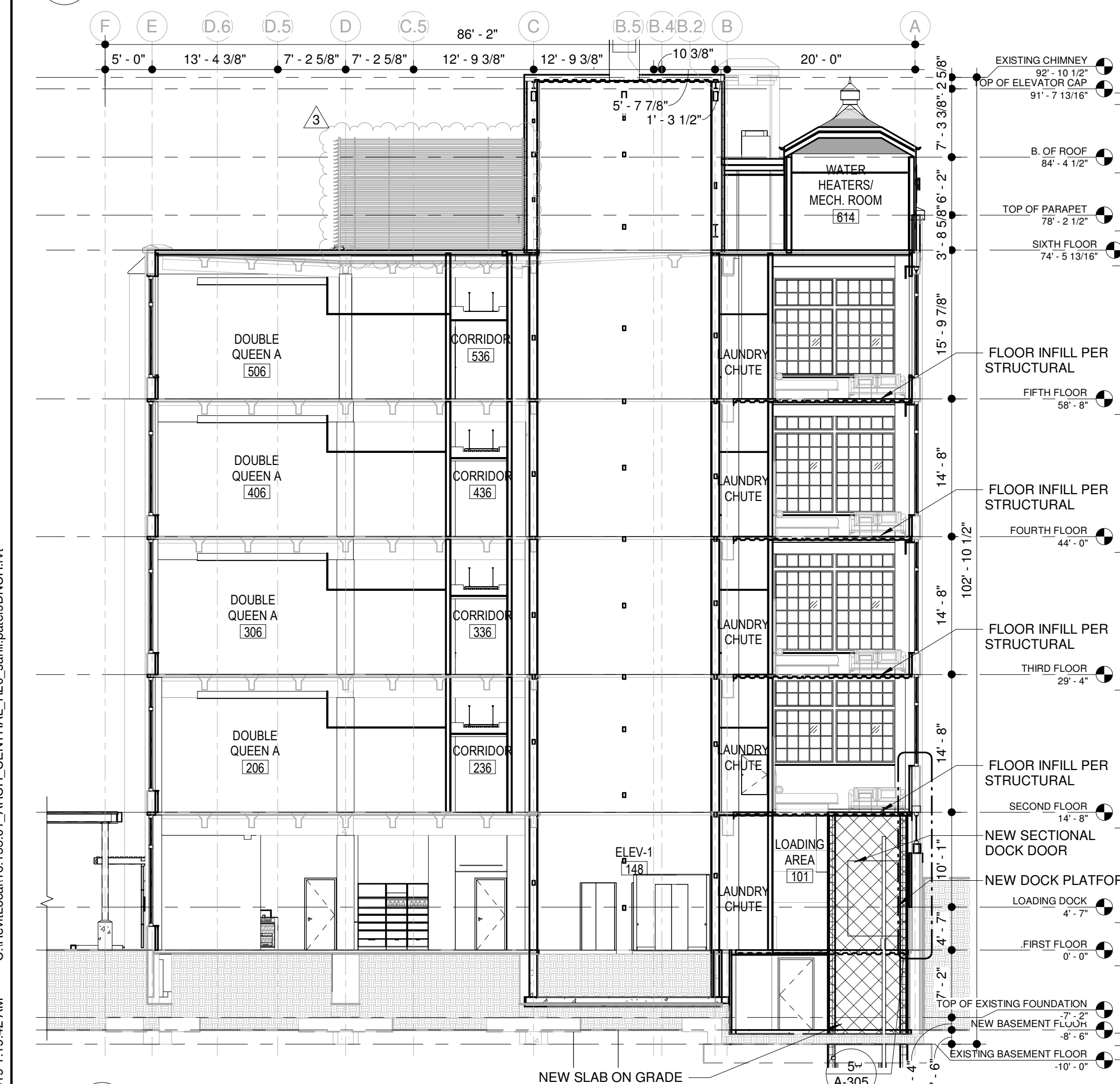

2 BUILDING SECTION -4
A-300 3/32" = 1'-0"

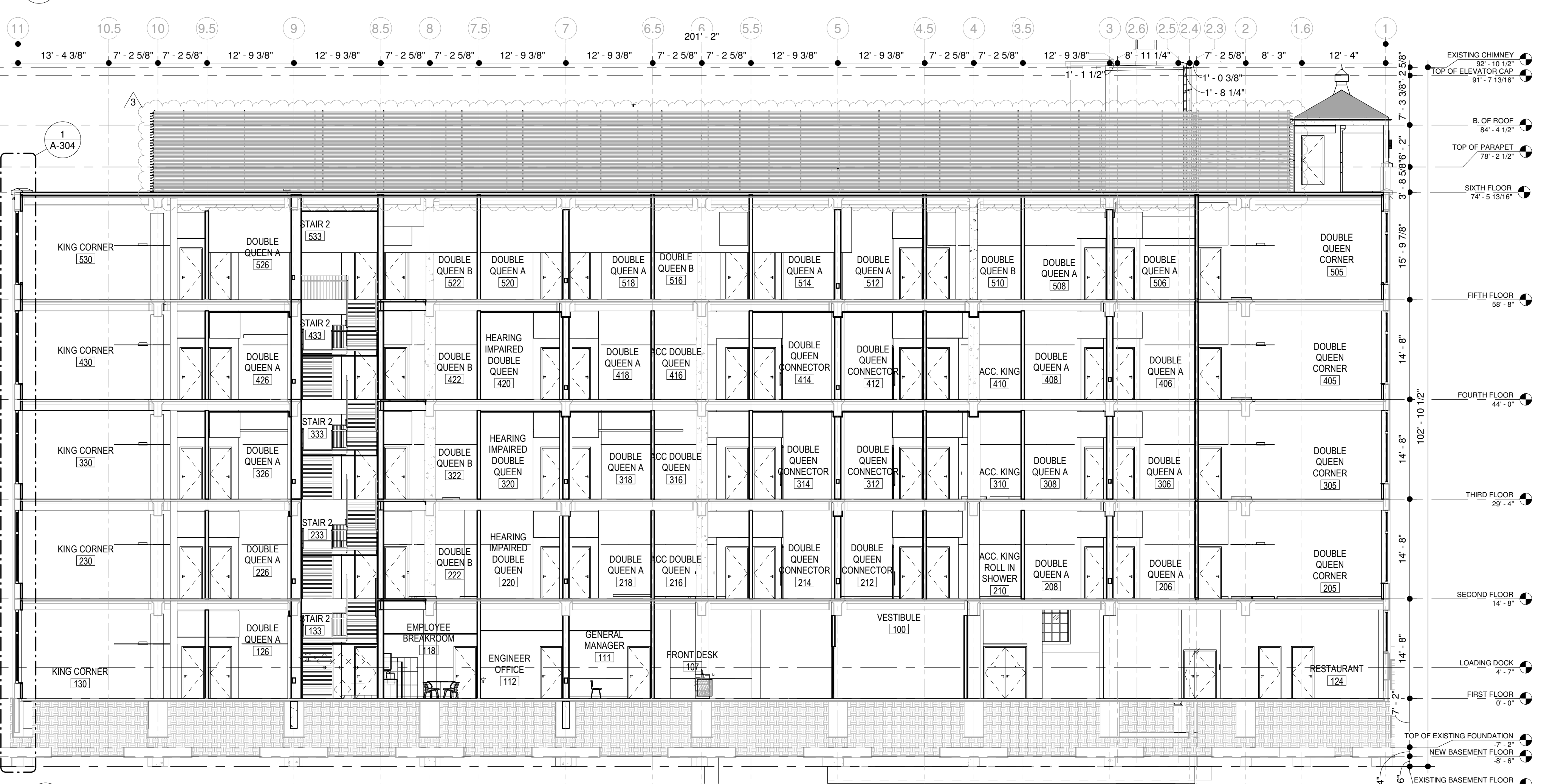

4 BUILDING SECTION -3
A-300 3/32" = 1'-0"

RUSSELL AND DAWSON INC.
ARCHITECTURE & ENGINEERING
1111 Main Street, East Hartford, CT 06108
TEL: (860) 238-1100 FAX: (860) 238-5272 EMAIL: info@rdawson.com

REVISIONS

NO.	DESCRIPTION	DATE	BY
3	GENERAL REVISION	11/27/2019	UKP

STAMP:

PROJECT: CONVERSION TO BOSTON HOTEL
175 ORLEANS STREET, BOSTON, MA 02128

FILE NO: 16155.01
SCALE: 3/32" = 1'-0"
DATE: 08/29/2018
DRAWN BY: AKP
CHECKED BY: UKP

SHEET TITLE: BUILDING SECTIONS
SHEET NUMBER: A-300

11/27/2019 1:19:42 AM C:\RevitLocal\16_155_01_ARCH_CENTRAL_R20_sahil.pane@DNUH.rvt

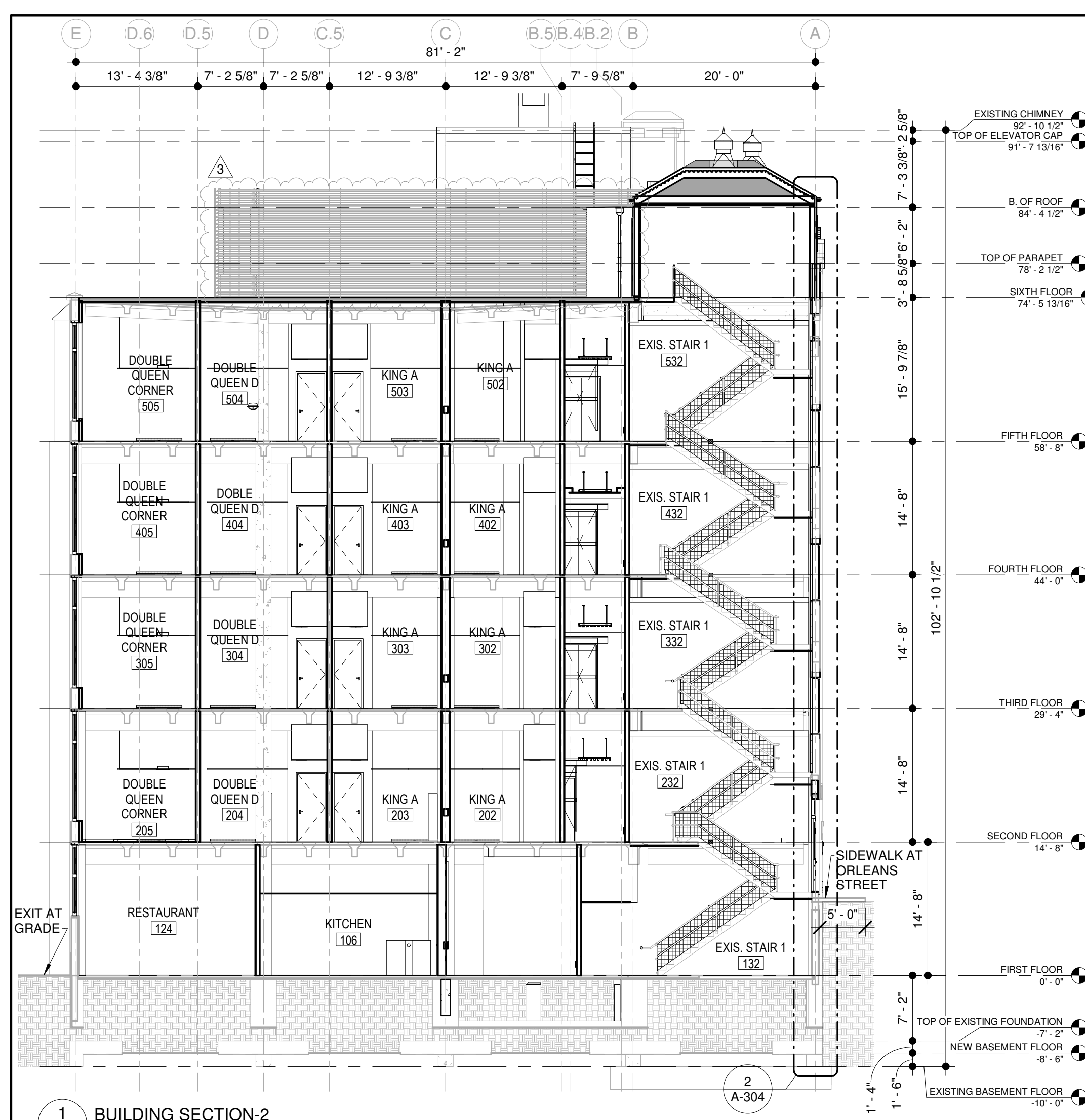

1 BUILDING SECTION-2
A-300
3/32" = 1'-0"

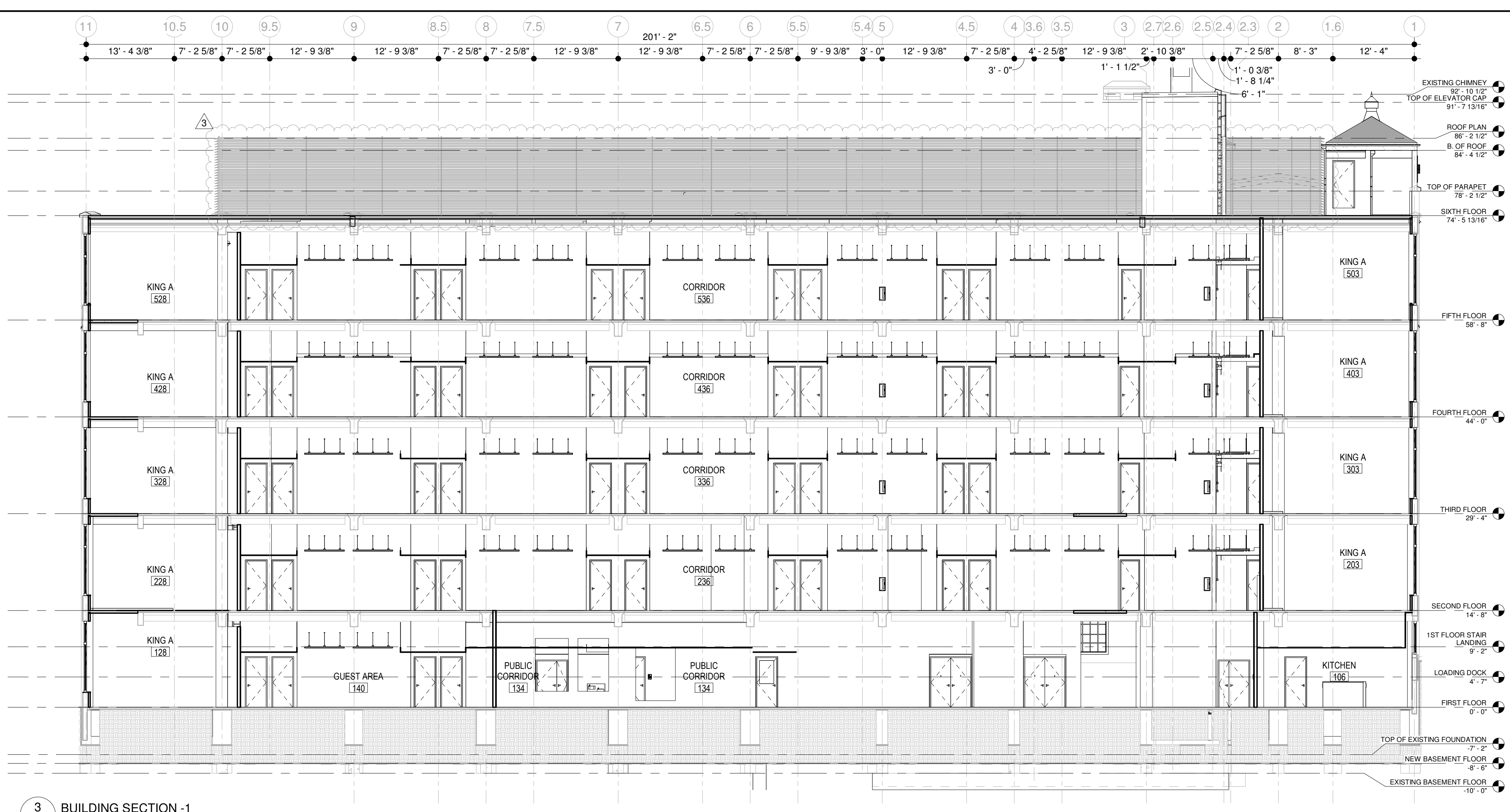

3 BUILDING SECTION -1
A-300
3/32" = 1'-0"

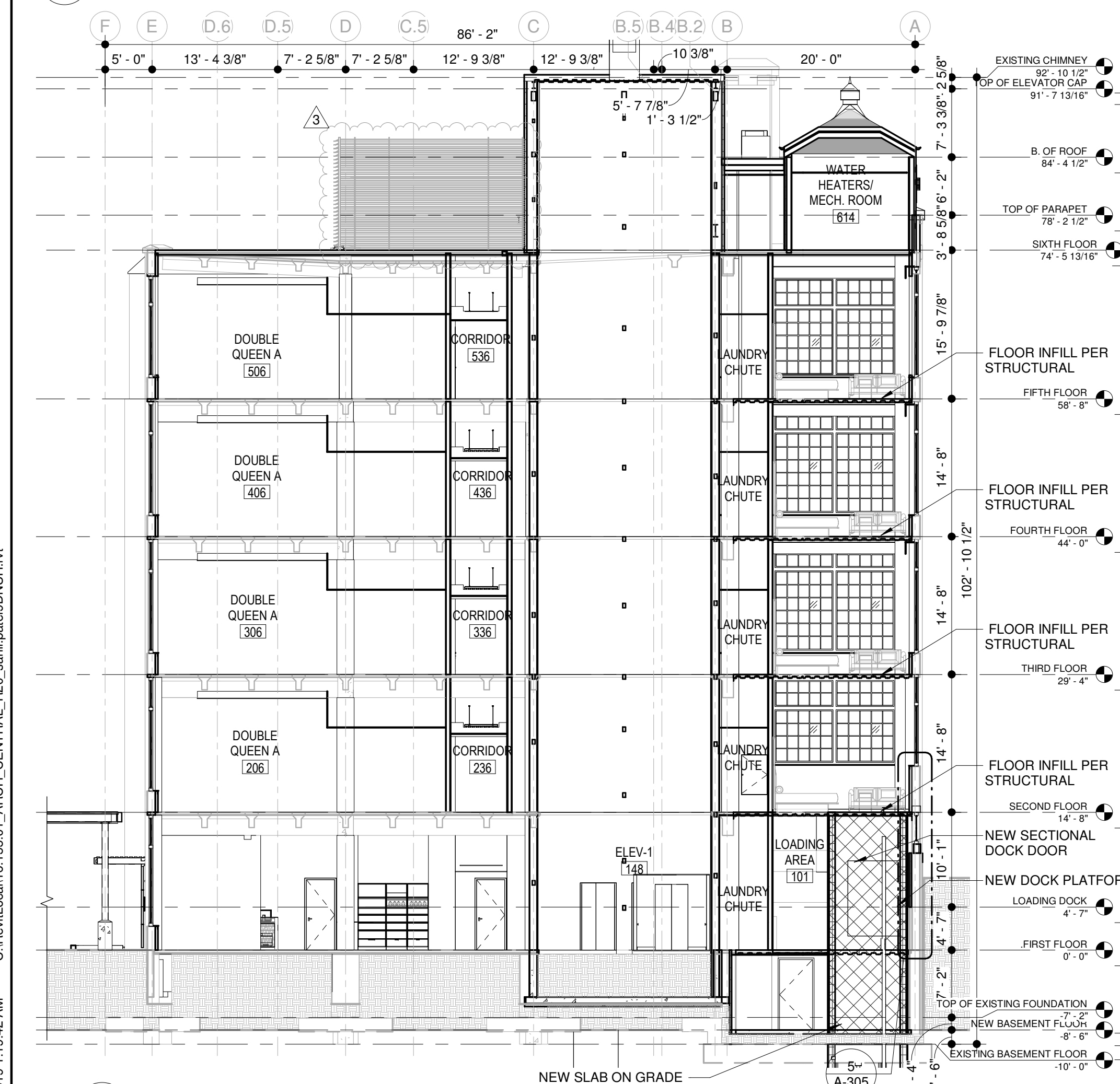

2 BUILDING SECTION -4
A-300
3/32" = 1'-0"

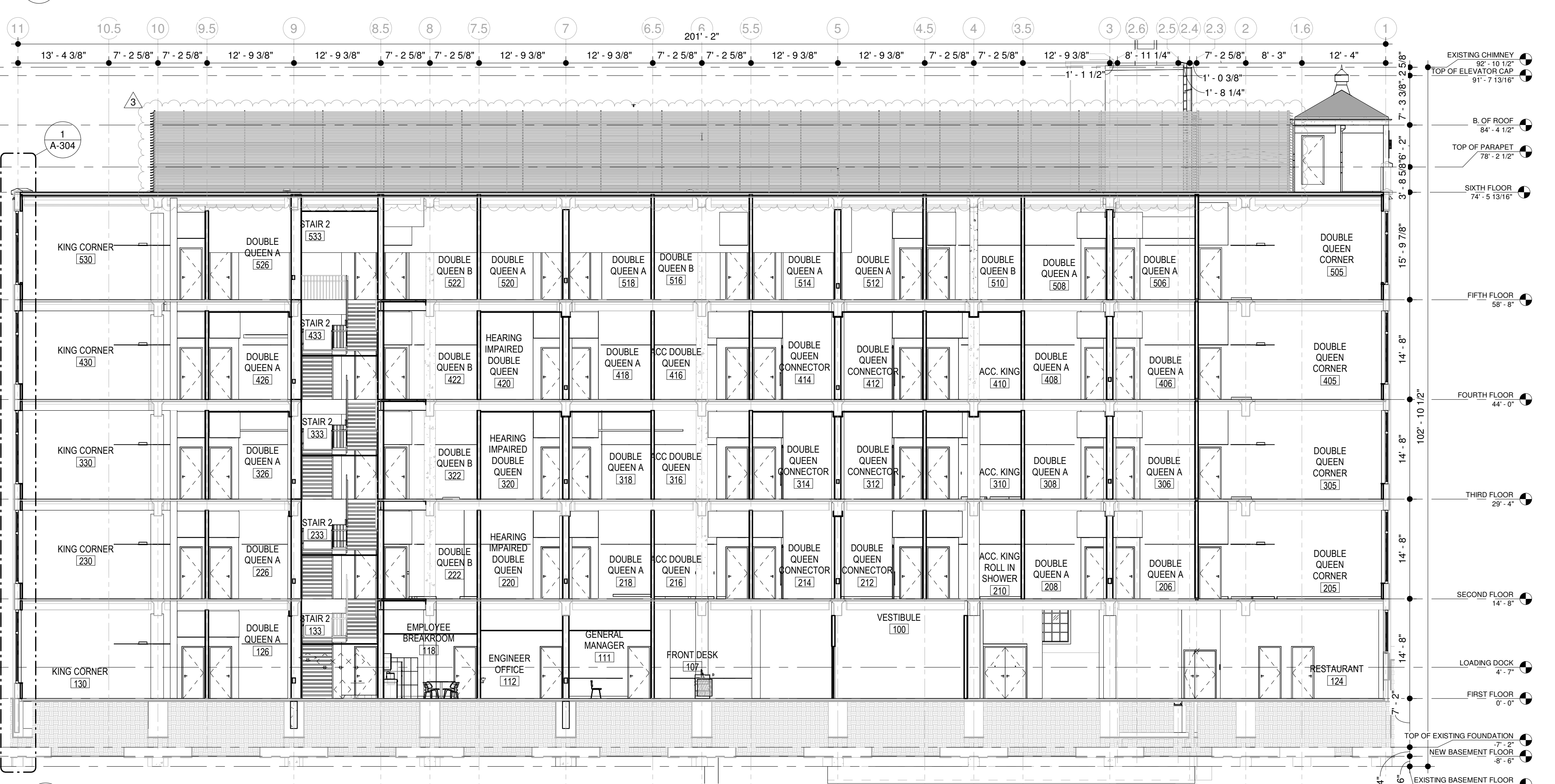

4 BUILDING SECTION -3
A-300
3/32" = 1'-0"

RUSSELL AND DAWSON INC.
ARCHITECTURE & ENGINEERING
1111 Main Street, East Hartford, CT 06108
TEL: (860) 282-1100 FAX: (860) 282-5272 EMAIL: info@rdawson.com

REVISIONS

NO.	DESCRIPTION	DATE	BY
3	GENERAL REVISION	11/27/2019	UKP

STAMP:

PROJECT: CONVERSION TO BOSTON HOTEL
175 ORLEANS STREET, BOSTON, MA 02128

FILE NO: 16155.01
SCALE: 3/32" = 1'-0"
DATE: 08/29/2018
DRAWN BY: AKP
CHECKED BY: UKP

SHEET TITLE: BUILDING SECTIONS
SHEET NUMBER: A-300

11/27/2019 1:19:42 AM C:\RevitLocal\16.155.01_ARCH_CENTRAL_R20_sahil.pane@DNJH.rvt

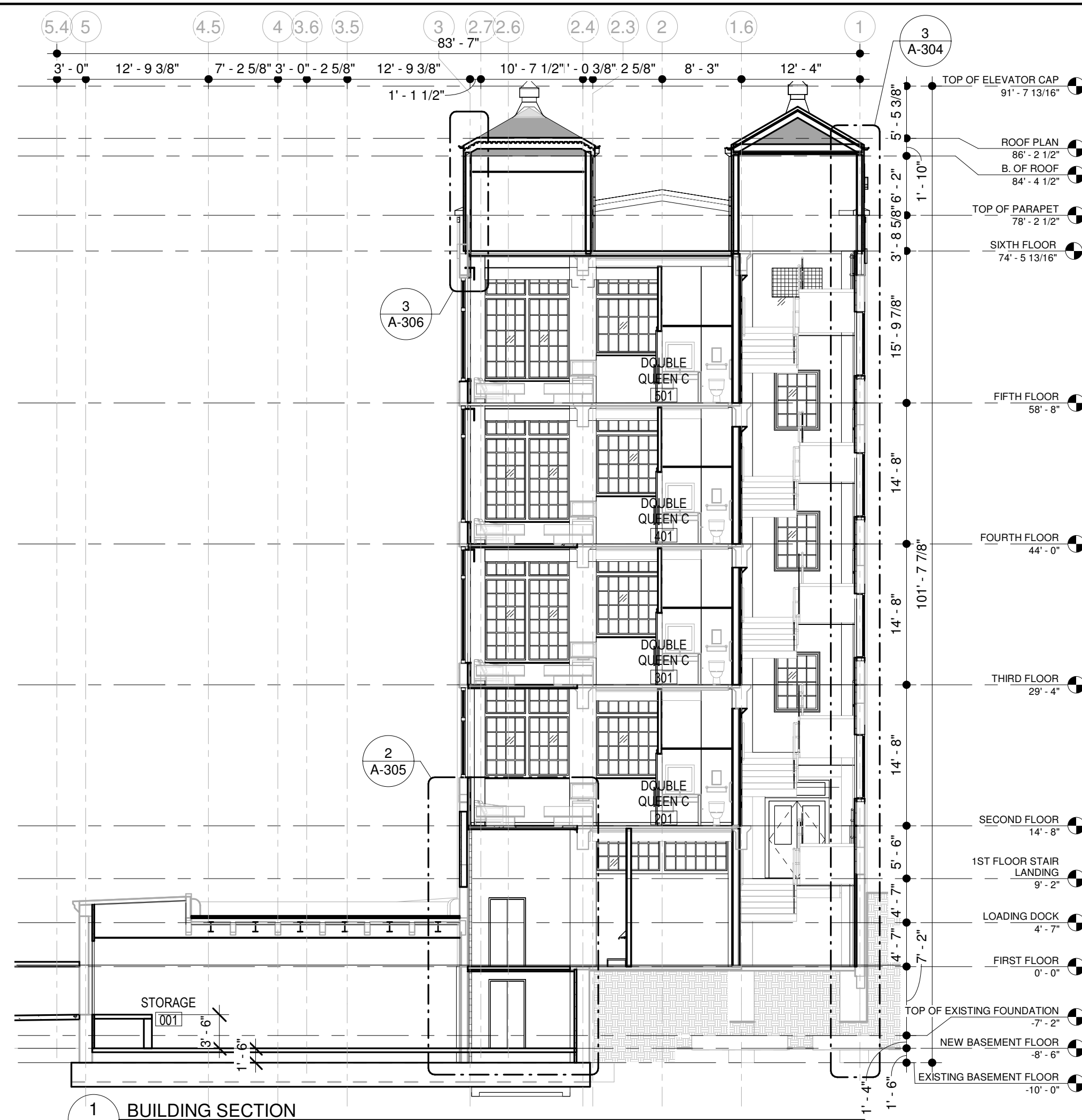

1 BUILDING SECTION
A-301 3/32" = 1'-0"

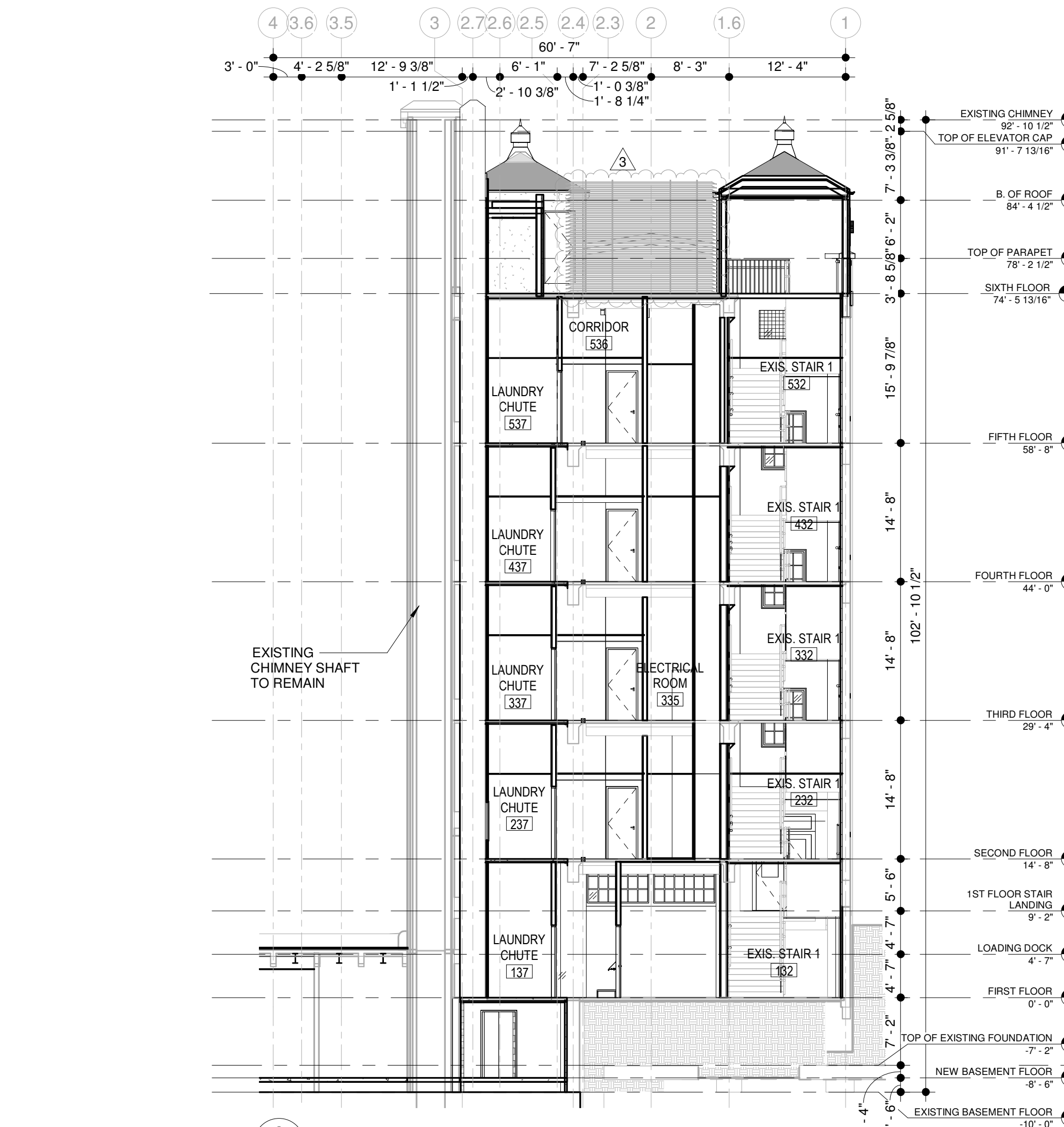

3 BUILDING SECTION
A-301 3/32" = 1'-0"

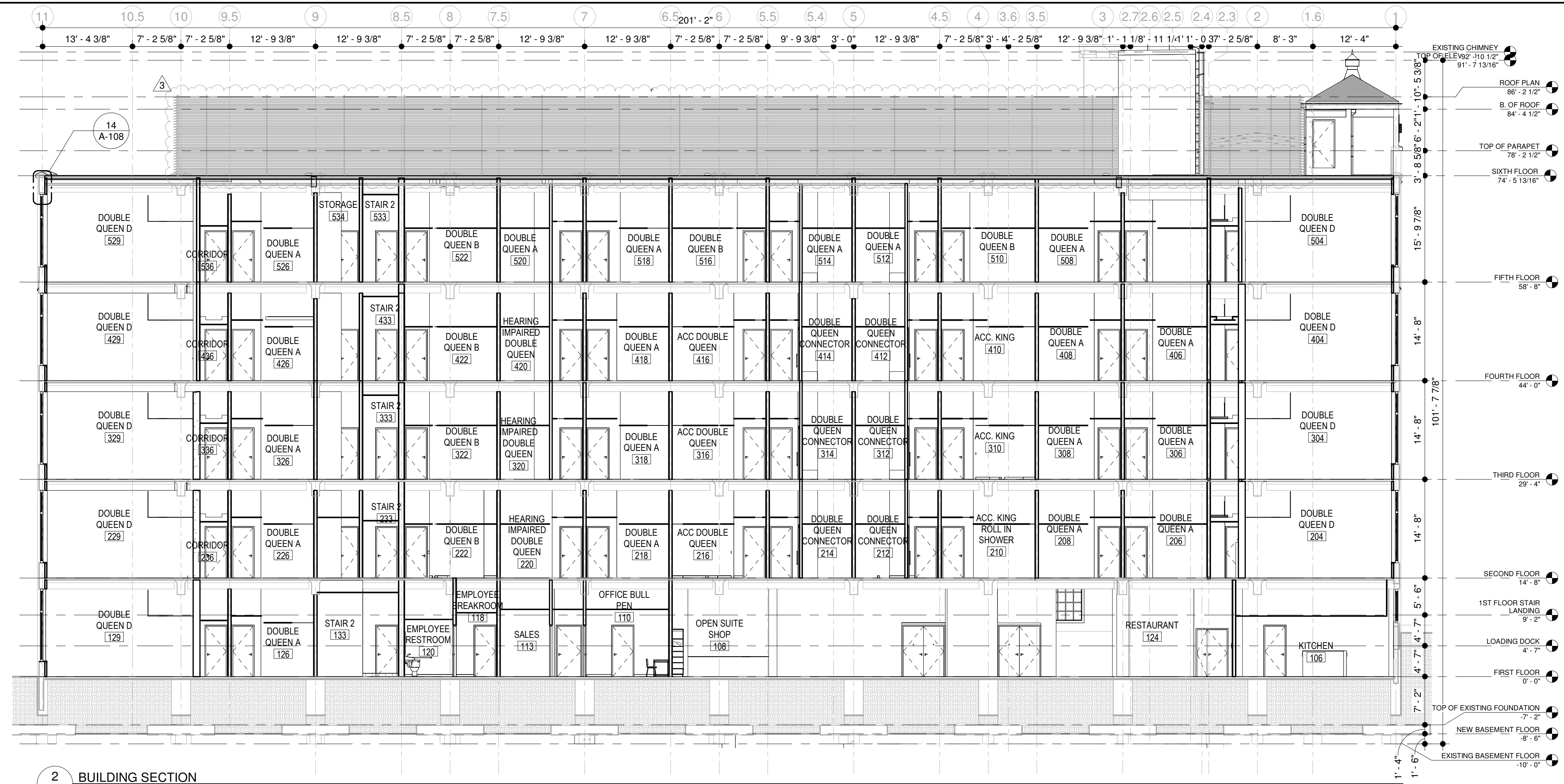

2 BUILDING SECTION
A-301 3/32" = 1'-0"

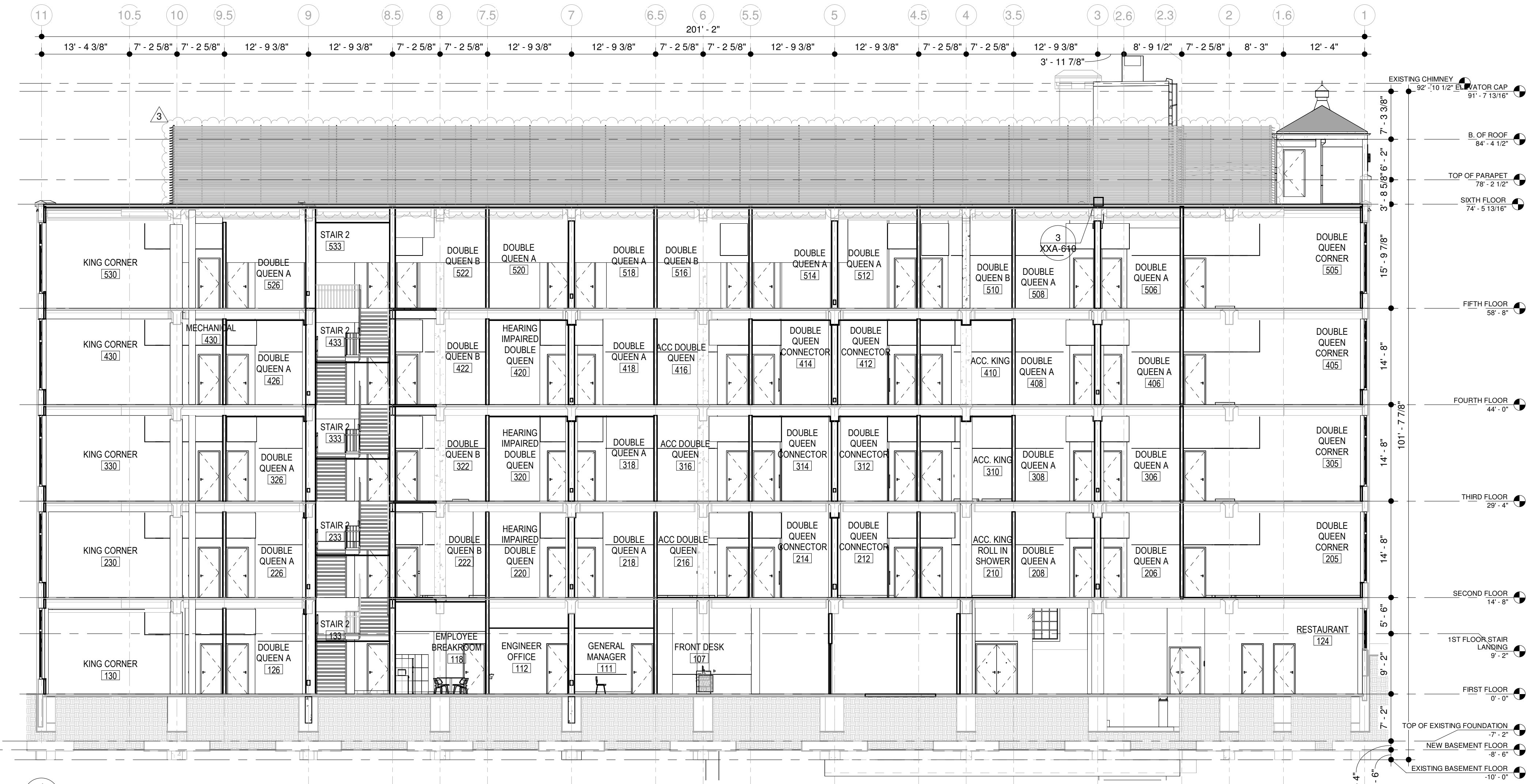

4 BUILDING SECTION
A-301 3/32" = 1'-0"

REVISIONS	
NO.	DESCRIPTION
3	GENERAL REVISION

DATE: 11/27/2019
BY: UKP

PROJECT: CONVERSION TO BOSTON HOTEL
175 ORLEANS STREET, BOSTON, MA 02128

FILE NO: 16155.01
SCALE: 3/32" = 1'-0"
DATE: 08/29/2018
DRAWN BY: AKP
CHECKED BY: UKP

SHEET TITLE: BUILDING SECTIONS
SHEET NUMBER: A-301

RUSSELL AND DAWSON INC.
ARCHITECTURE & ENGINEERING
1111 Main Street, East Hartford, CT 06108
TEL: (860) 282-1100 FAX: (860) 282-5272 EMAIL: info@rdai.com

DOORS TYPE

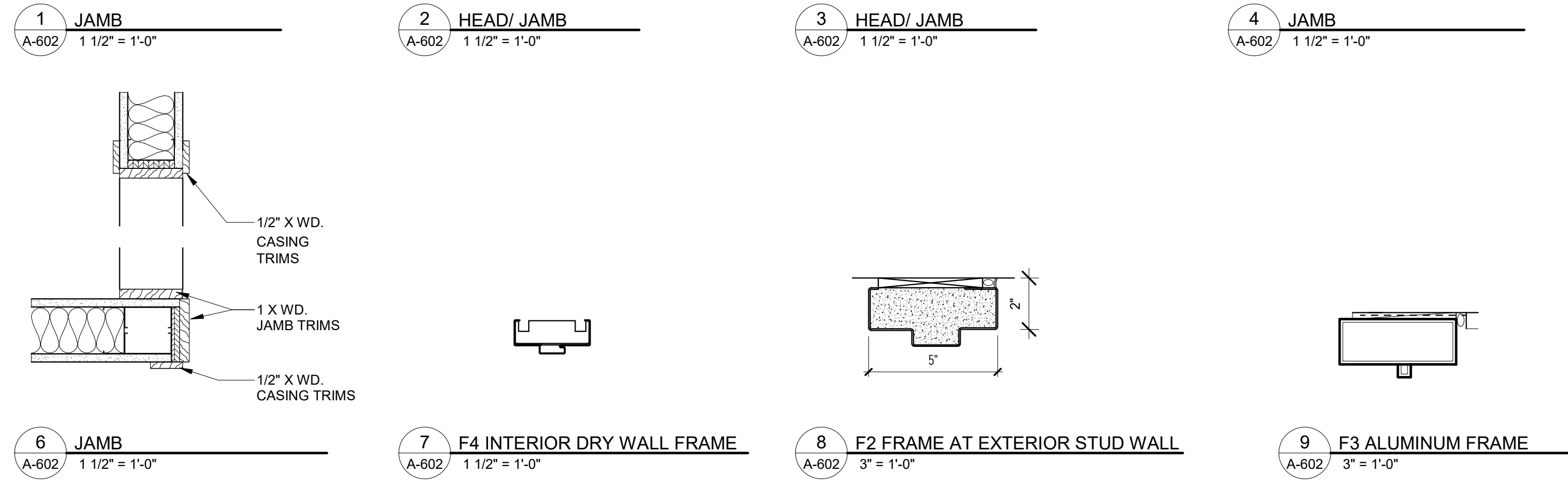
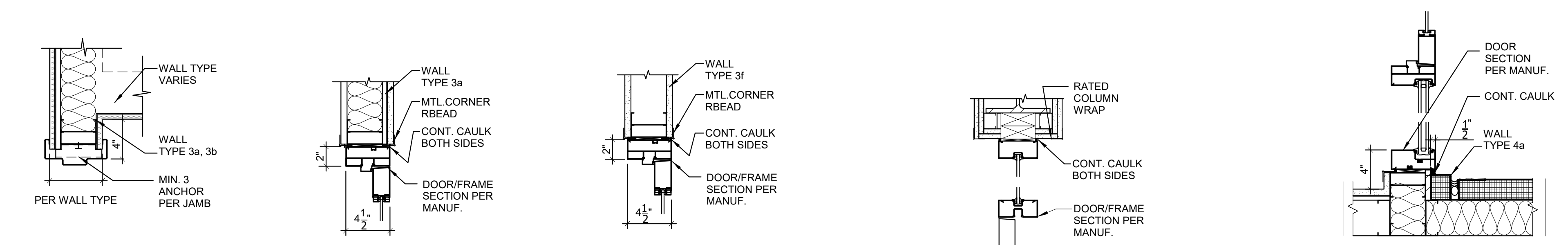
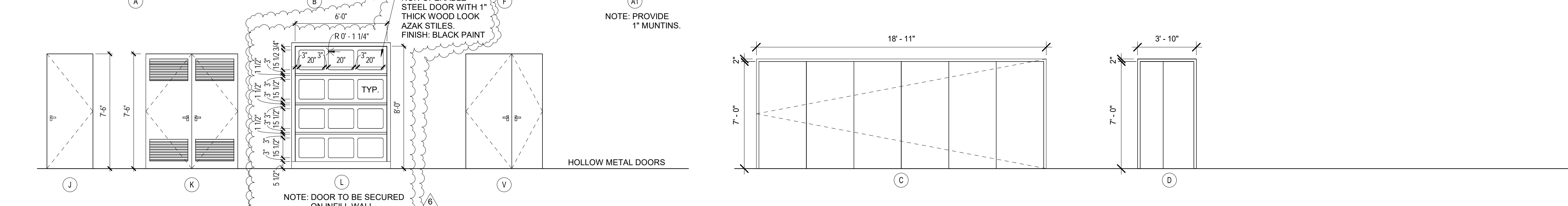
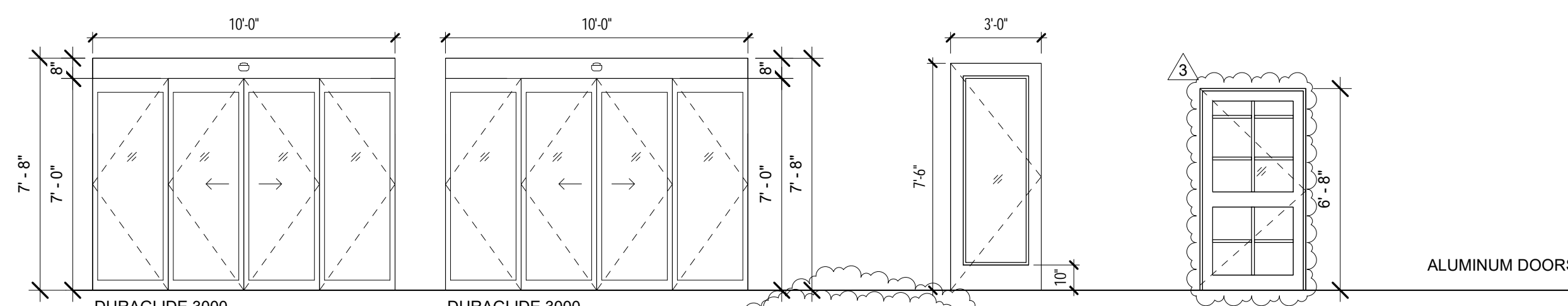

RUSSELL AND DAWSON INC.
ARCHITECTURE & ENGINEERING
1111 Main Street, East Hartford, CT 06108
TEL: (860) 282-1100 FAX: (860) 282-5272 E-MAIL: info@rdawson.com

THIS DOCUMENT, THE IDEAS, CONCEPTS, AND INSTRUMENT OF PROFESSIONAL SERVICE, IS THE PROPERTY OF RUSSELL AND DAWSON INC. AND IS NOT TO BE REPRODUCED, COPIED, OR TRANSMITTED IN ANY FORM OR BY ANY MEANS, ELECTRONIC OR MECHANICAL, INCLUDING PHOTOCOPYING, RECORDING, OR BY ANY INFORMATION STORAGE AND RETRIEVAL SYSTEM. WITHOUT THE WRITTEN PERMISSION OF RUSSELL AND DAWSON INC. ANY UNAUTHORIZED USE OF THIS DOCUMENT IS STRICTLY PROHIBITED. RUSSELL AND DAWSON INC. SHALL BE RESPONSIBLE FOR ANY AND ALL DAMAGES, INCLUDING REASONABLE ATTORNEY'S FEES, ARISING OUT OF OR FROM THE USE OF THIS DOCUMENT.

NO.	DESCRIPTION	DATE	BY
4	PER BPDA COMMENTS	01/03/2020	UKP
6	BPDA REVISION	11/23/2020	UKP

STAMP:

PROJECT:
CONVERSION TO BOSTON HOTEL
175 ORLEANS STREET, BOSTON, MA 02128

FILE NO.: 16155.01
SCALE: As indicated
DATE: 08/29/2018
DRAWN BY: AKP
CHECKED BY: UKP

SHEET TITLE:
DOOR DETAILS

SHEET NUMBER:
A-602

IVAS ENVIRONMENTAL
781.659.1690
315 WINTER STREET
NORWELL, MA 02061-1401

7715
53-7334/2113

10 Jul 21 Date CHECK AMOUNT

Pay to the Order of City of Boston \$ 1,500
one Thousand Five Hundred Dollars & no cents Dollars

Rockland FEDERAL CREDIT UNION
Serving generations - our legacy, our future

For Filing Fee - 155 Porter St. Stem Plus MP

7715

IVAS ENVIRONMENTAL
781.659.1690
315 WINTER STREET
NORWELL, MA 02061-1401

7716
53-7334/2113

10 Jul 21 Date CHECK AMOUNT

Pay to the Order of City of Boston \$ 550
Five Hundred Fifty Dollars & no cents Dollars

Rockland FEDERAL CREDIT UNION
Serving generations - our legacy, our future

For CAT 3 No 2 Filing Fee - 155 Porter St Stem Plus MP

7716

IVAS ENVIRONMENTAL
781.659.1690
315 WINTER STREET
NORWELL, MA 02061-1401

7713
53-7334/2113

10 Jul 21 Date CHECK AMOUNT

Pay to the Order of Commonwealth of Massachusetts \$ 737.50
Seven Hundred Thirty Seven Dollars and Fifty cents Dollars

Rockland FEDERAL CREDIT UNION
Serving generations - our legacy, our future

For 155 Porter St. - STATE Fee Stem Plus MP

7713

Checklist for Filing a Notice of Intent with Boston Conservation Commission

In order for the Boston Conservation Commission to effectively process your Notice of Intent, BCC requests that you complete the checklist below and include it with your submission. If you should need assistance please contact Commission Staff: 617-635-3850 (cc@boston.gov).

Please Submit the Following to the Conservation Commission:

- Two copies (a signed original and 1 copy) of a completed Notice of Intent (WPA Form 3)
- Two copies (a signed original and 1 copy) of a completed Boston Notice of Intent (Local Form)
- Two copies of plans (reduced to 11" X 17") in their final form with engineer's stamp affixed supporting calculations and other documentation necessary to completely describe the proposed work and mitigating measures. Plans must include existing conditions, the proposed project, erosion controls and mitigation measures, grading and spot elevations and all wetland resource areas and associated buffer zones. Some projects may require both an aerial view of the plans along with a profile view of plans depending on the scope of work.
- Two copies of an 8 ½" x 11" section of the [USGS quadrangle map](#) of the area, containing sufficient information for the Conservation Commission and the Department to locate the site of the work.
- (If applicable) Two copies the Federal Emergency Management Agency Flood Insurance Rate Map for the project site. FEMA Flood Maps: <https://msc.fema.gov/portal>.
- Two copies of the determination regarding the Natural Heritage and Endangered Species Program: Review Section C. Other Applicable Standards and Requirements of the Notice of Intent, page 4 of 8, pertaining to wildlife habitat. The Conservation Commission and the [Natural Heritage & Endangered Species Program](#) have the maps necessary to make this determination. See Fig. 3.
- (If applicable) Two hard copies of a Stormwater Report to document compliance with the Stormwater Management Standards per 310 CMR 10.05(6)(k)-(q), including associated drainage calculations for rooftops, parking lots, driveways, etc., for the required design storm events.
- (If applicable) A narrative detailing best management practices for stormwater management as set forth in the Stormwater Management Standards of the Massachusetts Department of Environmental Protection and any separate standards and guidelines prepared by the City and the Boston Water and Sewer Commission.
- (If applicable) Two hard copies of the Checklist for Stormwater Report
- Details of the stormwater management system, including: catch basins, oil separating tanks, detention basins, outfalls, sewer connections, etc. See Plan Sheet C102, 02 Jan 20.
- Any photographs related to the project representing the wetland resource areas.
- Two copies of a detailed project narrative describing the following: an overview of the entire project, the work proposed within wetland resource areas and/or buffer zones; how the performance standards specific to the wetland resource areas will be met (listing out each performance standard); a consideration of the effect that projected sea level rise, changes in storm intensity and frequency, and other consequences of climate change may have on the resource areas and proposed activities; construction equipment and material involved; and measures to protect wetland resource areas and mitigate impacts. The applicant shall also include narrative on how they plan to integrate climate change and adaptation planning considerations into their project to promote climate resilience to protect and promote Resource Area Values and functions into the future.
- Two copies of an Abutters List, Affidavit of Service and [Abutter Notification](#), filed concurrently with the Notice of Intent. Abutter notices shall be sent in both English and the second most commonly spoken language(s) in the neighborhood(s) where the project is proposed. Notices shall also include Babel notice cards for additional translation and language access services. [All abutters within 300' of the project](#)

Checklist for Filing a Notice of Intent with Boston Conservation Commission

[property line](#) must be notified including those in a neighboring municipality. In such an instance, a copy of the filing must also be sent to the local Conservation Commission of the neighboring municipality.
EXCEPTION: When work is in land under water bodies and waterways or on a tract of land greater than 50 acres, written notification must only be given to abutters within 300 feet of the “project site.”

- Two copies of the BPDA Climate Resiliency Checklist (for new buildings). This can be completed online at <http://www.bostonplans.org/planning/planning-initiatives/article-37-green-building-guidelines>. Please print the pdf that you will receive via email after completion and include it in your submission.
- Electronic copies.** Documents may be submitted via email, or via an email link to downloadable documents.



To minimize the use of non-recyclable materials ***please do not include vinyl or plastic binders, bindings, folders or covers with the filing.*** Staples and binder clips are good choices.

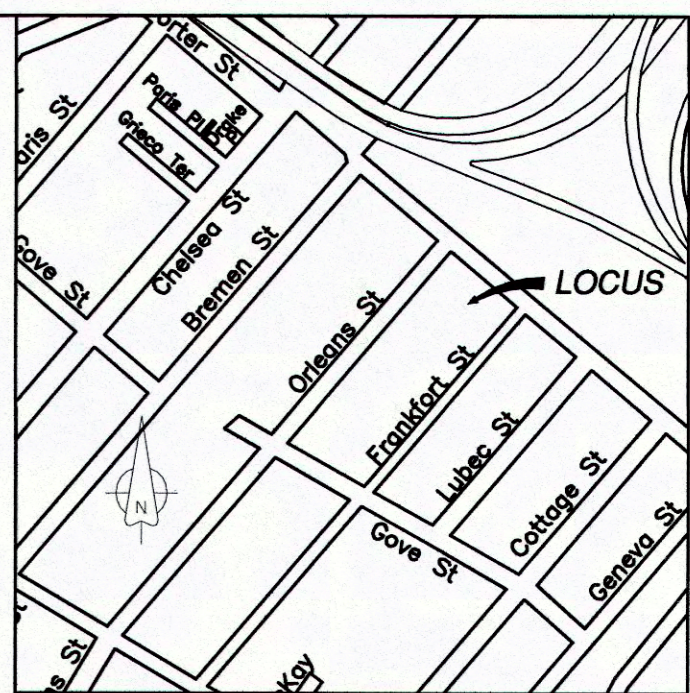
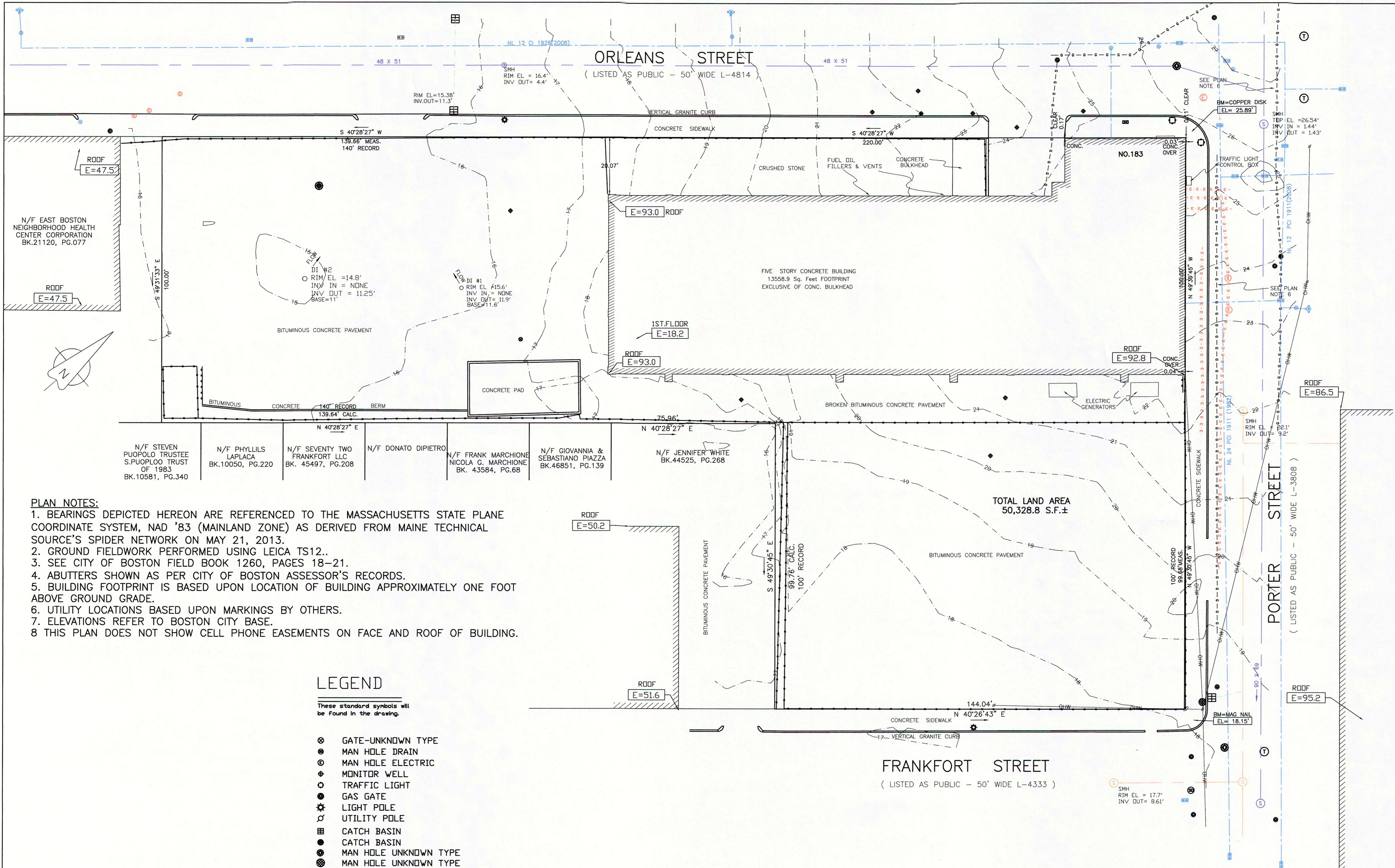

Site Plan
Land in
BOSTON,
(East Boston),
Suffolk County,
Massachusetts

Record Owner:
183 Orleans Street, LLC
Deed Book 52219, page 157
Deed Book 57405, page 188



- PLAN NOTES:**
1. BEARINGS DEPICTED HEREON ARE REFERENCED TO THE MASSACHUSETTS STATE PLANE COORDINATE SYSTEM, NAD '83 (MAINLAND ZONE) AS DERIVED FROM MAINE TECHNICAL SOURCE'S SPIDER NETWORK ON MAY 21, 2013.
 2. GROUND FIELDWORK PERFORMED USING LEICA TS12..
 3. SEE CITY OF BOSTON FIELD BOOK 1260, PAGES 18-21.
 4. ABUTTERS SHOWN AS PER CITY OF BOSTON ASSESSOR'S RECORDS.
 5. BUILDING FOOTPRINT IS BASED UPON LOCATION OF BUILDING APPROXIMATELY ONE FOOT ABOVE GROUND GRADE.
 6. UTILITY LOCATIONS BASED UPON MARKINGS BY OTHERS.
 7. ELEVATIONS REFER TO BOSTON CITY BASE.
 - 8 THIS PLAN DOES NOT SHOW CELL PHONE EASEMENTS ON FACE AND ROOF OF BUILDING.

LEGEND

- These standard symbols will be found in the drawing.
- ⊗ GATE-UNKNOWN TYPE
 - ⊙ MAN HOLE DRAIN
 - ⊕ MAN HOLE ELECTRIC
 - ⊚ MONITOR WELL
 - ⊙ TRAFFIC LIGHT
 - ⊙ GAS GATE
 - ⊙ LIGHT POLE
 - ⊙ UTILITY POLE
 - ⊙ CATCH BASIN
 - ⊙ CATCH BASIN
 - ⊙ MAN HOLE UNKNOWN TYPE
 - ⊙ MAN HOLE UNKNOWN TYPE
 - ⊙ MAN HOLE SEWER
 - CHAIN LINK FENCE
 - - - MARKED GAS LINE
 - - - MARKED ELECTRIC LINE
 - - - MARKED WATER LINE
 - ⊞ GATE-BWSC

DATE: February 15, 2017
REV. Apr. 6, 2017

© 2017 ALL RIGHTS RESERVED
ANDERSON SURVEYS, INC.
Professional Land Surveyors
800 HIGH STREET
HANSON, MA 02341-0149
(781) 293-3349

kanderson@andersonsurveys.com
SCALE: 1" = 16'

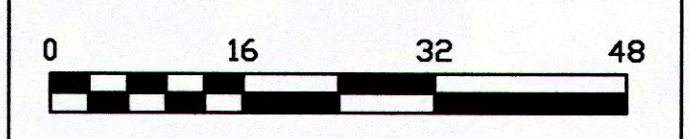

RESERVED FOR REGISTRY OF DEEDS

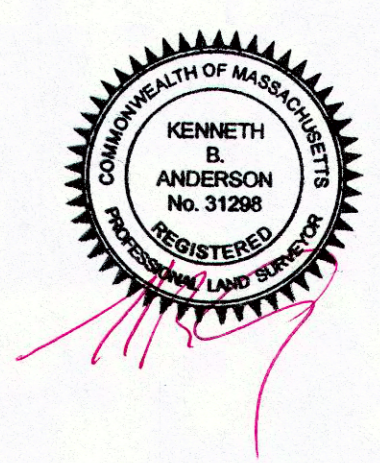

SEWER FLOW CALCULATIONS:

SEWER DESIGN FLOWS BASED ON 310 CMR 15

EXISTING USE:	INDUSTRIAL BUILDING (540 PEOPLE)
UNIT FLOW:	15 GPD / PERSON
EXISTING FLOW:	8,100 GPD
PROPOSED USE:	123 ROOM HOTEL + 130 SEAT RESTAURANT
UNIT FLOW:	110 GPD PER ROOM 35 GPD PER SEAT
HOTEL FLOW:	13,530 GPD
RESTAURANT FLOW:	4,550 GPD
TOTAL NEW FLOW:	18,080 GPD
NET CHANGE:	+9,980 GPD (SEWER FLOW INCREASE)
GREASE TRAP SIZING:	15 GAL PER SEAT
UNIT FLOW:	1,950 GAL. → 2,000 GAL TRAP PROPOSED.
MIN. SIZE:	

DRAINAGE CALCULATIONS SUMMARY

(FULL DRAINAGE CALCULATIONS WERE PREPARED USING HYDROCAD V10)

1" STORM EVALUATION	
TOTAL IMPERVIOUS AREA:	41,835 SF
1" STORM VOLUME:	3,486 CF
RECHARGE VOLUME:	
CHAMBERS:	
VOL. / CHAMBER AT 27" FULL:	45.4 CUFT (PER STORMTECH)
64 CHAMBERS:	45.4 X 64 = 2,906 CUFT
STONE:	
DIMENSIONS: 60.58' X 39.5' X 33" =	6,580 CUFT
LESS CHAMBERS: 6,580 - 2,906 =	3,674 CUFT
30% VOIDS: 3,674 X 0.3 =	1,102 CUFT
TOTAL:	2,906 + 1,102 = 4,008 CUFT
4,008 > 3,486 = OK	

INSPECTION SIGN-OFF SCHEDULE

ITEM NO.	DESCRIPTION OF SERVICE	QTY.	BWSC INSPECTOR DATE	COMMENTS
1	SANITARY PIPE INSTALLATION	68'		
2	SANITARY MANHOLE INSTALLATION	1		
3	SANITARY CHIMNEY CONNECTION	1		
4	REMOVE SEWER SERVICE	1		
5	GREASE TRAP INSTALLATION	1		
6	VIDEO NEW SANITARY PIPES	1		
7	OUTLET CONTROL STRUCTURE (OCS)	1		
8	DRAINAGE PIPE INSTALLATION	320'		
9	DYE TEST SEWER	1		
10	DRAINAGE CHIMNEY CONNECTION	1		
11	DON'T DUMP PLAQUE INSTALLATION	6		
12	VIDEO NEW DRAIN PIPES	1		
13	UNDERGROUND RECHARGE SYSTEM	1		
14	DYE TEST NEW DRAINAGE SYSTEM	1		
15	FIELD CONNECTION AT MAIN	1		
16	6" FIRE SERVICE INSTALLATION	1		
17	4" DOMESTIC SERVICE INSTALLATION	1		
18	BACKFLOW CONNECTION	1		
19	NEW 2" METER INSTALLATION	1		
20	TRENCH DRAIN	1		
21	DRAIN MANHOLE 1	1		
22	DRAIN MANHOLE 2	1		
23	DRAIN MANHOLE 3	1		
24	DRAIN MANHOLE 4	1		
25	DRAIN MANHOLE 5 (DIVERSION MANHOLE)	1		
26	DRAIN MANHOLE 6 (SUMP AND HOOD)	1		
27	REMOVE 4" FIRE SERVICE	1		
28	REMOVE 4" FIRE SERVICE	1		
29	REMOVE 4" FIRE SERVICE	1		
30	SHALLOW CATCH BASIN PCB1	1		
31	SHALLOW CATCH BASIN PCB2	1		
32	SHALLOW CATCH BASIN PCB3	1		
33	TYP CATCH BASIN WITH OIL TRAP PCB4	1		
34	TYP CATCH BASIN WITH OIL TRAP PCB5	1		

GRADING AND UTILITY NOTES:

- EXISTING CONDITIONS INFORMATION IS REPRODUCED FROM THE "SITE PLAN" PREPARED BY ANDERSON SURVEYS, INC. DATED APRIL 2, 2017.
- ALL ELEVATIONS REFER TO BOSTON CITY BASE.
- WHERE PROPOSED GRADES MEET EXISTING GRADES, CONTRACTOR SHALL BLEND GRADES TO PROVIDE A SMOOTH TRANSITION BETWEEN EXISTING AND NEW WORK. PONDING AT TRANSITION AREAS WILL NOT BE ALLOWED.
- ENSURE ALL EXISTING (TO REMAIN) AND PROPOSED MANHOLE COVERS PROPERLY IDENTIFY UTILITY SERVICED.
- CONTRACTOR SHALL VERIFY EXISTING GRADES AND NOTIFY OWNER'S REPRESENTATIVE OF ANY DISCREPANCIES.
- CONTRACTOR SHALL ADJUST ALL UTILITY ELEMENTS MEANT TO BE FLUSH WITH GRADE (CLEAN-OUTS, UTILITY MANHOLES, ETC) THAT IS AFFECTED BY SITE WORK OR GRADE CHANGES, WHETHER SPECIFICALLY NOTED ON PLANS OR NOT.
- ALL CONSTRUCTION TO BE DONE IN ACCORDANCE WITH BOSTON WATER AND SEWER STANDARDS.
- WHERE EXISTING UTILITY IS FOUND TO CONFLICT WITH THE PROPOSED WORK, THE LOCATION, ELEVATION, AND SIZE OF THE UTILITY SHALL BE ACCURATELY DETERMINED WITHOUT DELAY BY THE CONTRACTOR AND THE INFORMATION FURNISHED TO THE ENGINEER FOR RESOLUTION OF THE CONFLICT.
- THE CONTRACTOR SHALL ALTER THE MASONRY OF THE TOP SECTIONS OF ALL EXISTING DRAINAGE STRUCTURES AS NECESSARY FOR CHANGES IN GRADE, AND RESET ALL FRAMES, GRATES, AND BOXES TO THE PROPOSED FINISHED GRADE.
- PROTECT AND MAINTAIN EXISTING ON-SITE DRAINAGE STRUCTURES AND PIPES UNLESS OTHERWISE NOTED.
- DRAINAGE PIPES SHALL BE SDR 35 UNLESS OTHERWISE NOTED.
- ALL SEWER PIPES SHALL BE SDR 35 UNLESS OTHERWISE NOTED.
- ALL WATER PIPES 4" OR LARGER SHALL BE CLASS 56, ZINC COATED DUCTILE IRON.
- ALL SOILS REMOVED FROM THE SITE SHALL BE DISPOSED OF BY THE CONTRACTOR AT CONTRACTOR'S EXPENSE. SOILS MAY BE CONTAMINATED. CONTRACTOR SHALL CONSULT WITH OWNER'S LICENSED SITE PROFESSIONAL (LSP) PRIOR TO ANY EXCAVATION TO CONFIRM EXCAVATION AND DISPOSAL REQUIREMENTS.

TV INSPECTION OF SEWERS & DRAINS

- THE CONTRACTOR SHALL FURNISH ALL EQUIPMENT, LABOR, MATERIALS, AND SUPERVISION AS REQUIRED TO INSPECT THE INTERIOR OF ALL SEWERS AND DRAINS, PROVIDE VIDEO RECORDINGS WITH VOICE DESCRIPTIONS AS WELL AS FULL INSPECTION REPORTS, AND ALL OTHER APPURTENANT WORK, WITHIN THE LIMITS SHOWN ON THE DRAWINGS, AS DIRECTED BY THE ENGINEER, AND AS SPECIFIED IN THE BOSTON WATER & SEWER (BWS) SPECIFICATION "TELEVISION INSPECTION OF SEWERS AND DRAINS" AS LATEST REVISED AVAILABLE AT: [HTTP://WWW.BWSC.ORG/REGULATIONS/CONSTRUCTION_SPECS/CONSTRUCTION_SPECS](http://www.bwsc.org/regulations/construction_specs/construction_specs)
- PIPES SHALL NOT BE INSPECTED UNTIL COMPLETELY CLEANED IN ACCORDANCE WITH THE SPECIFICATION NOTED IN #1 AND TO THE SATISFACTION OF THE BWSC INSPECTOR AND OWNER'S REPRESENTATIVE.

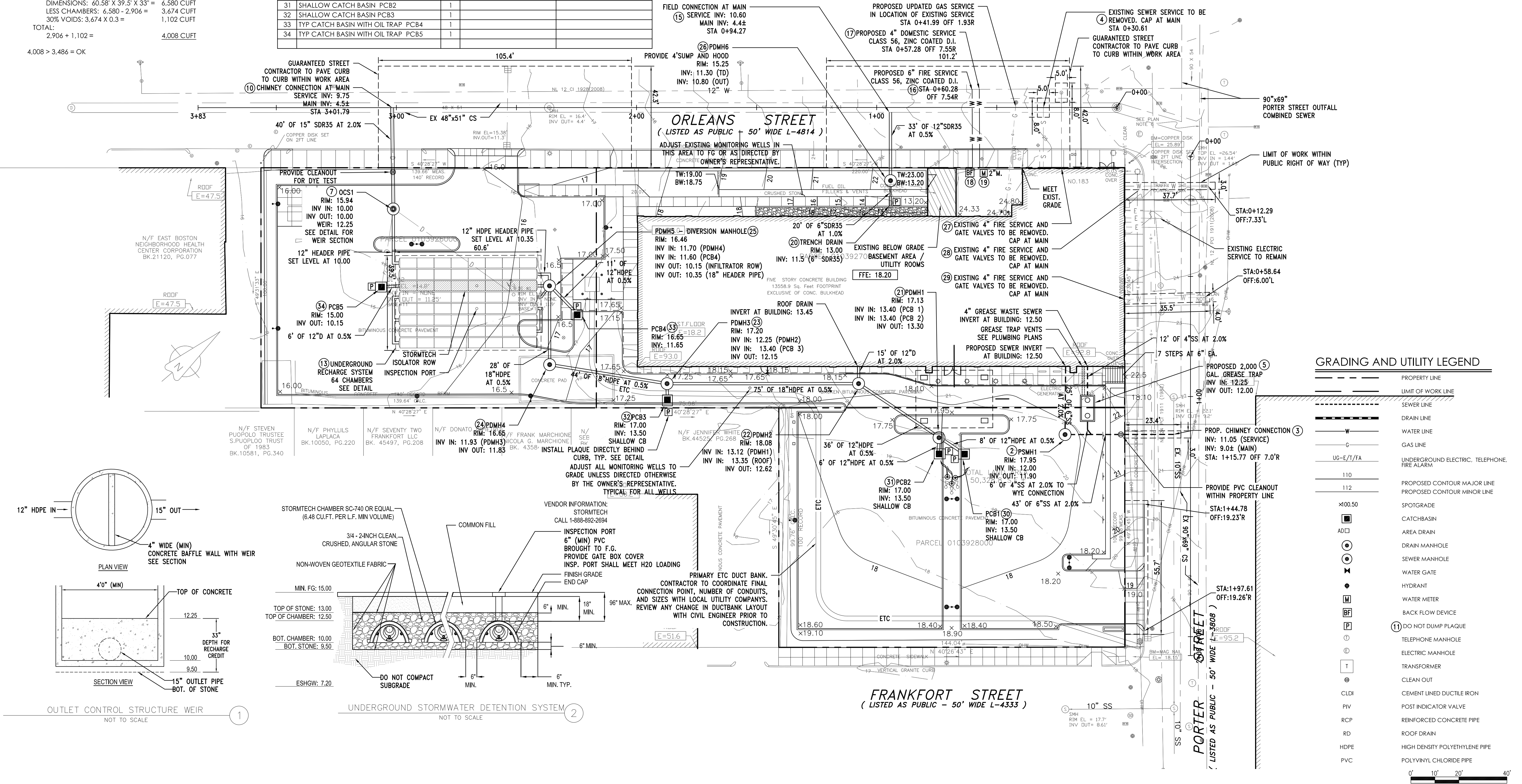

GRADING AND UTILITY LEGEND

---	PROPERTY LINE
---	LIMIT OF WORK LINE
---	SEWER LINE
---	DRAIN LINE
---	WATER LINE
---	GAS LINE
---	UG-E/T/FA
---	UNDERGROUND ELECTRIC, TELEPHONE, FIRE ALARM
---	110
---	PROPOSED CONTOUR MAJOR LINE
---	PROPOSED CONTOUR MINOR LINE
---	SPOTGRADE
---	CATCHBASIN
---	AREA DRAIN
---	DRAIN MANHOLE
---	SEWER MANHOLE
---	WATER GATE
---	HYDRANT
---	WATER METER
---	BACK FLOW DEVICE
---	11) DO NOT DUMP PLAQUE
---	TELEPHONE MANHOLE
---	ELECTRIC MANHOLE
---	TRANSFORMER
---	CLEAN OUT
---	CEMENT LINED DUCTILE IRON
---	PV
---	POST INDICATOR VALVE
---	REINFORCED CONCRETE PIPE
---	RD
---	ROOF DRAIN
---	HDPE
---	HIGH DENSITY POLYETHYLENE PIPE
---	PVC
---	POLYVINYL CHLORIDE PIPE

CIVIL ENGINEER: PVI SITE DESIGN, LLC
 PVI Site Design, LLC
 Civil Engineering - Land Enhancements
 Master Planning - Project Management
 509-206-1030

PROJECT: HOTEL REDEVELOPMENT
 155 PORTER STREET, EAST BOSTON, MA
 CLIENT/APPLICANT: HUDSON 62 REALTY LLC
 440 BEDFORD ST, LEXINGTON, MA 01824

REV:
 1: 12-13-2017 BWSC COMMENTS
 2: 02-08-2018 BWSC COMMENTS
 3: 03-07-2018 BWSC COMMENTS
 4: 04-19-2018 85% OWNER'S REVIEW
 5: 07-06-2018 100% ISSUED FOR CONST.
 6: 09-17-2019 BPOA COMMENTS
 7: 11-26-2019 BPOA COMMENTS
 8: 01-02-2020 BPOA COMMENTS

SEAL: TIMOTHY J. POWELL
 CIVIL ENGINEER
 No. 46808
 PROFESSIONAL SEAL

ISSUED FOR CONSTRUCTION
 DECEMBER 8, 2017

GRADING AND UTILITY PLAN
 BWS SITE PLAN #17410

SCALE: 1"=20'
JOB NO: 003-003
FILE: 003-003-G.dwg
DRAWN: TJP
CHECKED: TJP
SHEET NO: C102

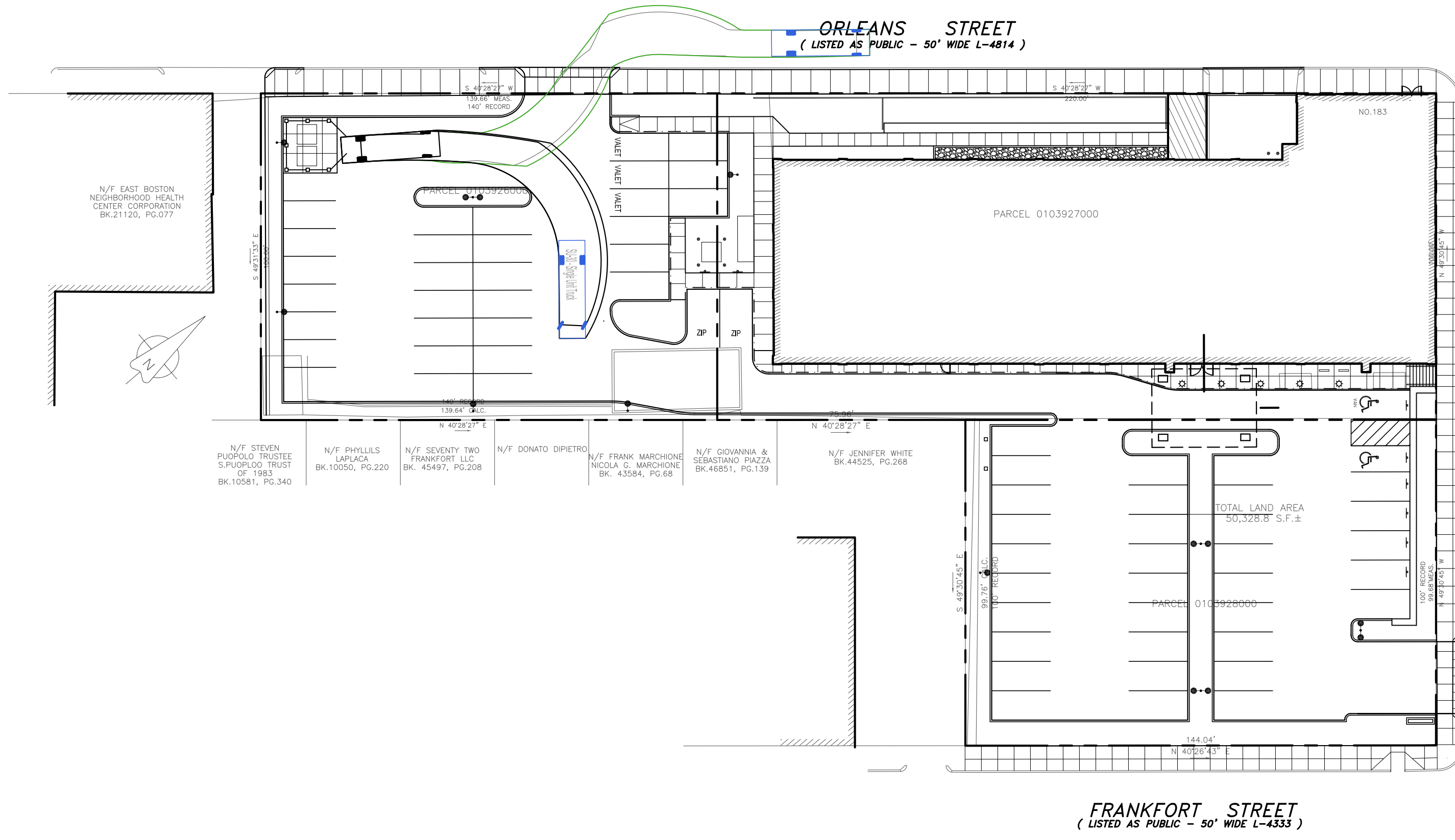

TRUCK REVERSE AND EXIT MOVEMENT
SCALE: 1"=30'

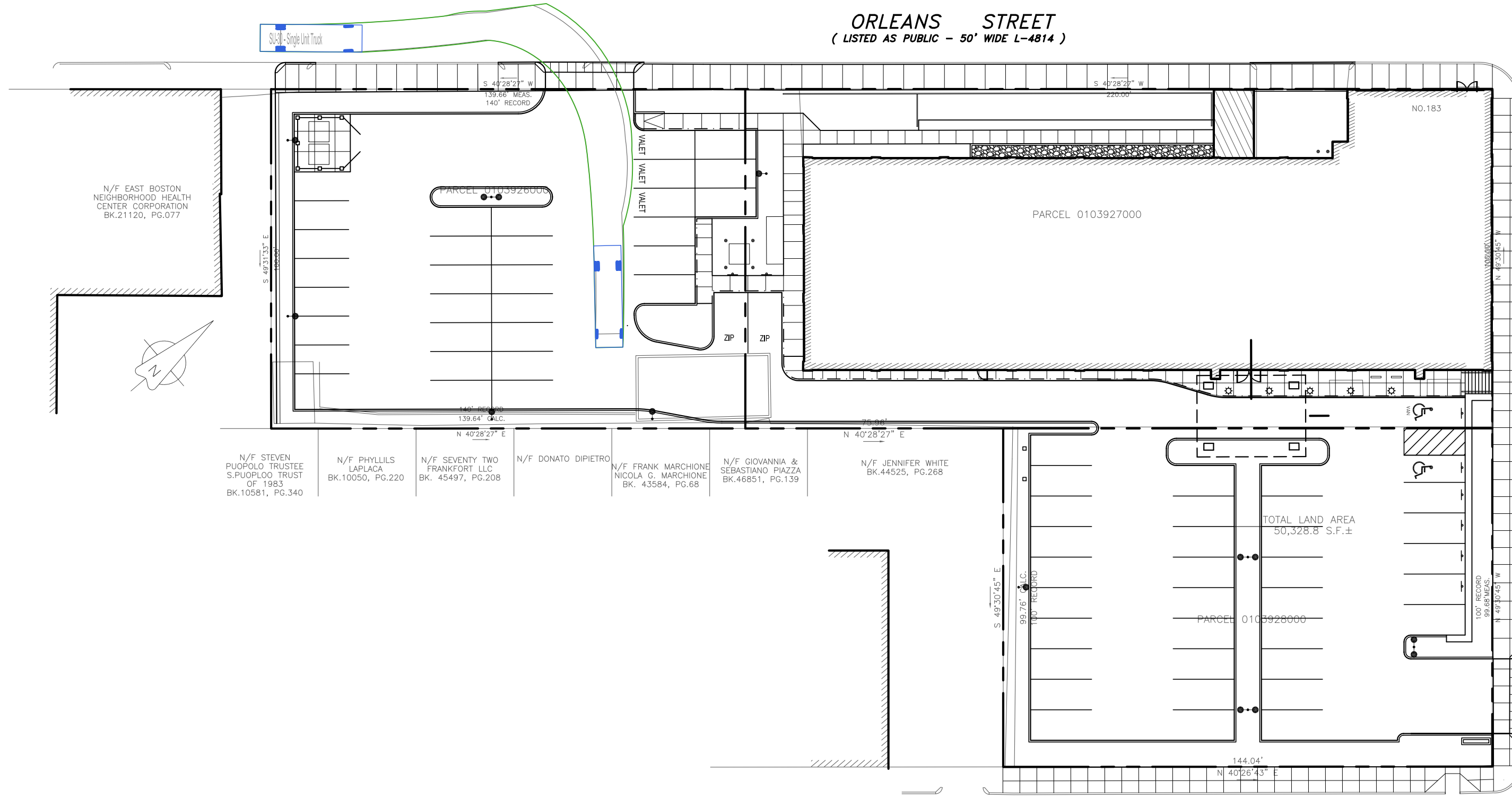

TRUCK RIGHT TURN INTO SITE
SCALE: 1"=30'

PORTER STREET
(LISTED AS PUBLIC - 50' WIDE L-3888)

PORTER STREET
(LISTED AS PUBLIC - 50' WIDE L-3888)

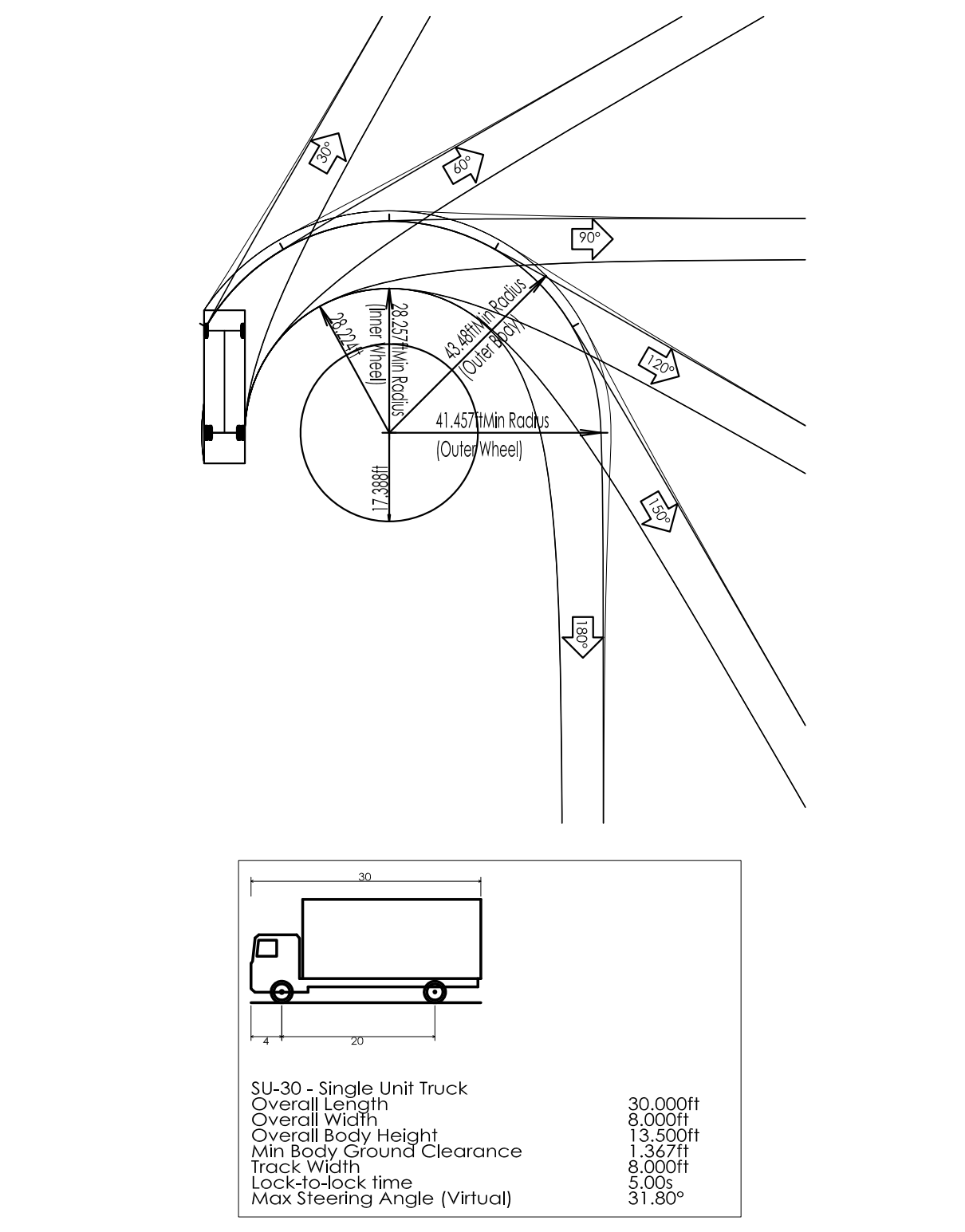

TYPICAL DELIVERY TRUCK TURNING TEMPLATE
NOT TO SCALE

REV.:

1: 12-13-2017	BWSC COMMENTS
2: 02-08-2018	BWSC COMMENTS
3: 03-07-2018	BWSC COMMENTS
4: 04-19-2018	85% OWNER'S REVIEW
5: 07-06-2018	100% ISSUED FOR CONST.
6: 09-17-2019	BPDA COMMENTS
7: 11-26-2019	BPDA COMMENTS
8: 01-02-2020	BPDA COMMENTS

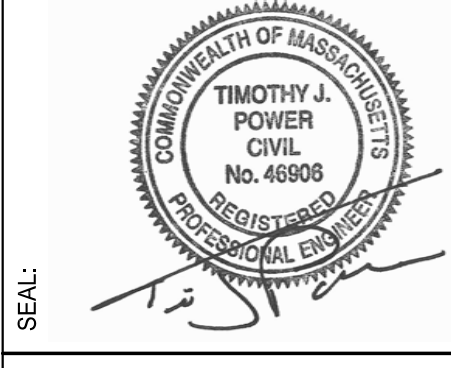

ISSUED FOR CONSTRUCTION
DECEMBER 8, 2017

TRUCK TURNING MOVEMENTS

BWSC SITE PLAN #17410

SCALE: 1"=20'

JOB NO: 003-003

FILE: 003-003-G.dwg

DRAWN: TJP

CHECKED: TJP

SHEET NO:

C103

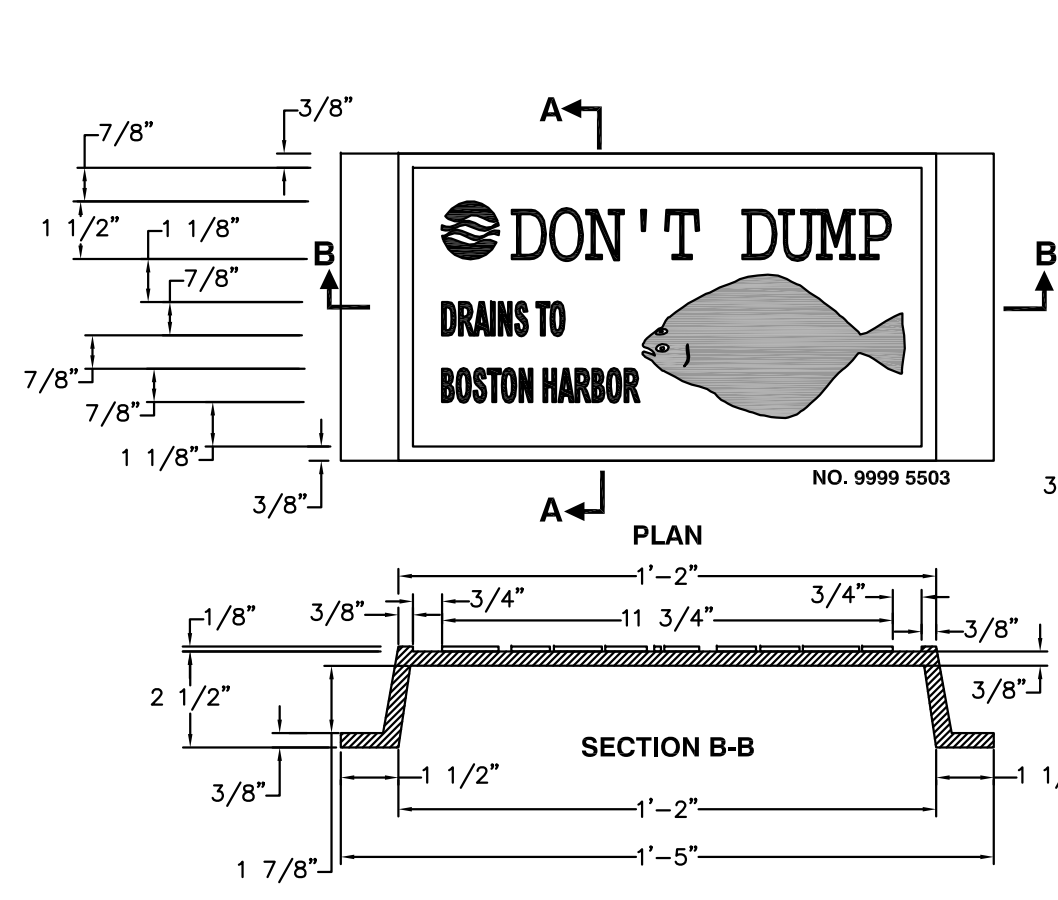

1 CATCH BASIN SIGN DETAILS
NOT TO SCALE

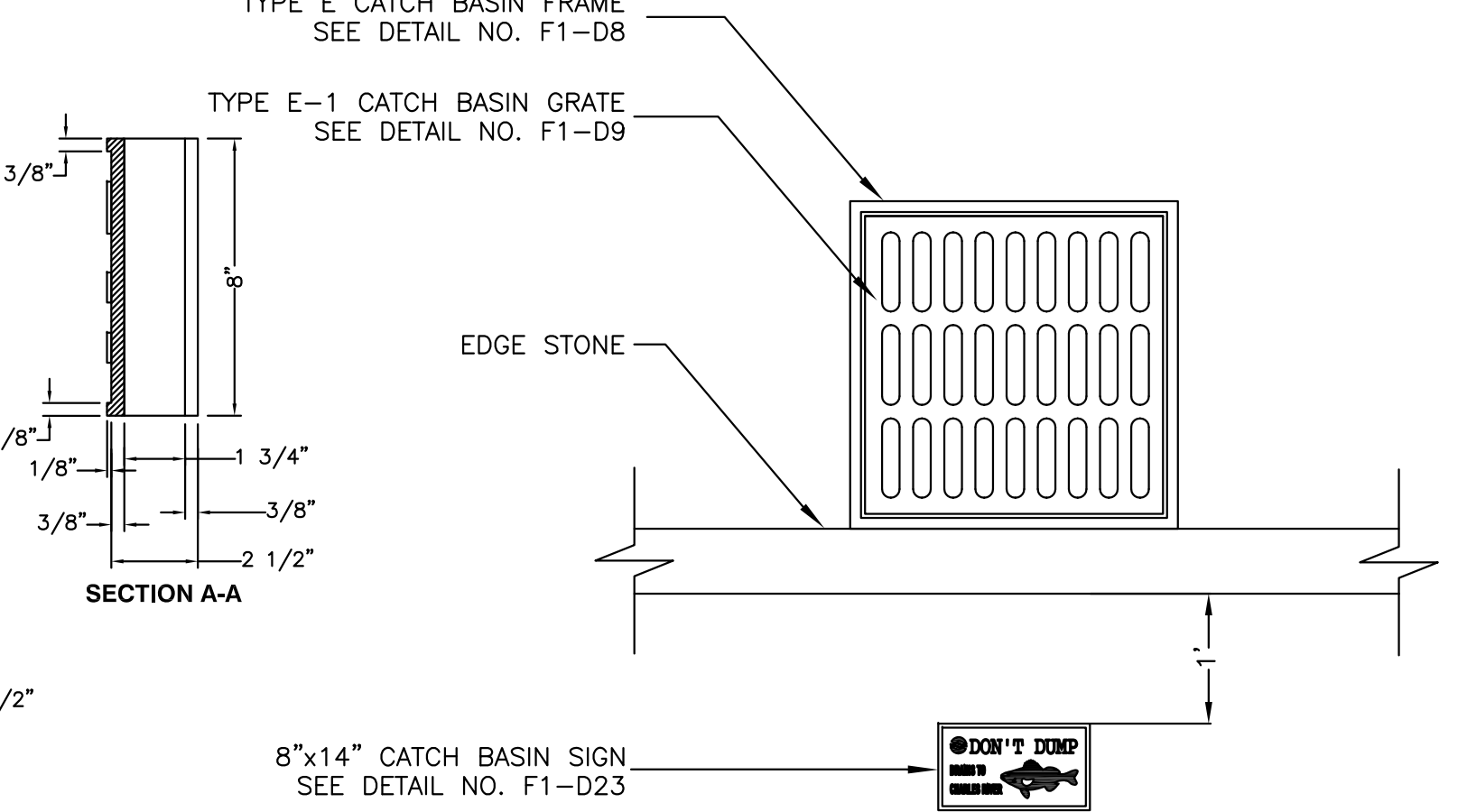

TYPE E CATCH BASIN FRAME
SEE DETAIL NO. F1-D8

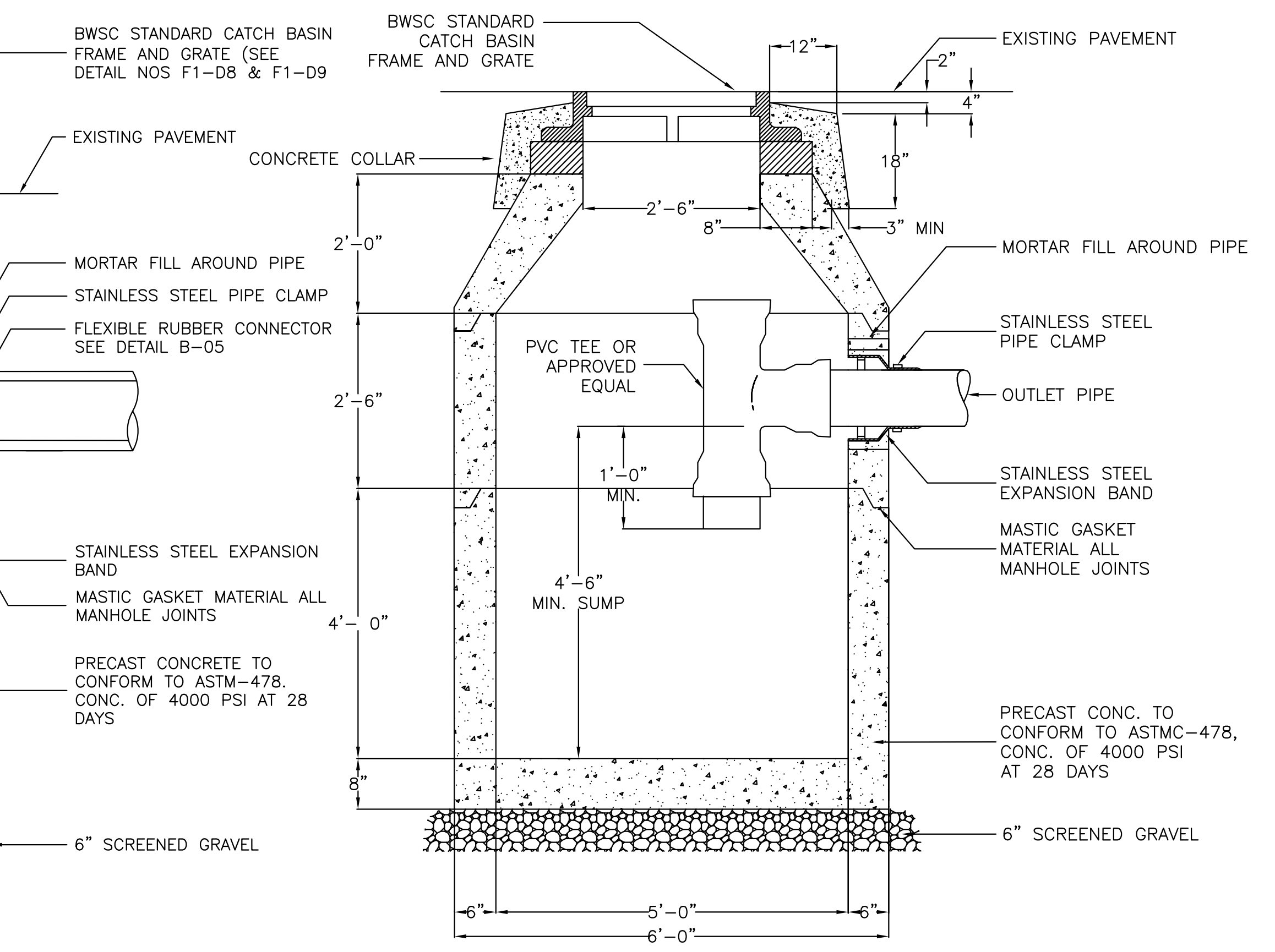

3 SHALLOW CATCH BASIN - BWSC DETAIL B-01d
NOT TO SCALE

- NOTES:
1. OPENING IN CONCRETE WALL SHALL BE CORED USING HIGH SPEED DIAMOND DRILL
 2. ALL METAL FIXTURES SHALL BE OF STAINLESS STEEL
 3. SERVICE LINE SHALL BE FLUSH WITH THE INSIDE OF THE CONCRETE PIPE OR WALL
 4. IF TRUNK LINE DIAMETER IS LESS THAN 24" THEN A SADDLE TYPE CONNECTION WILL BE USED

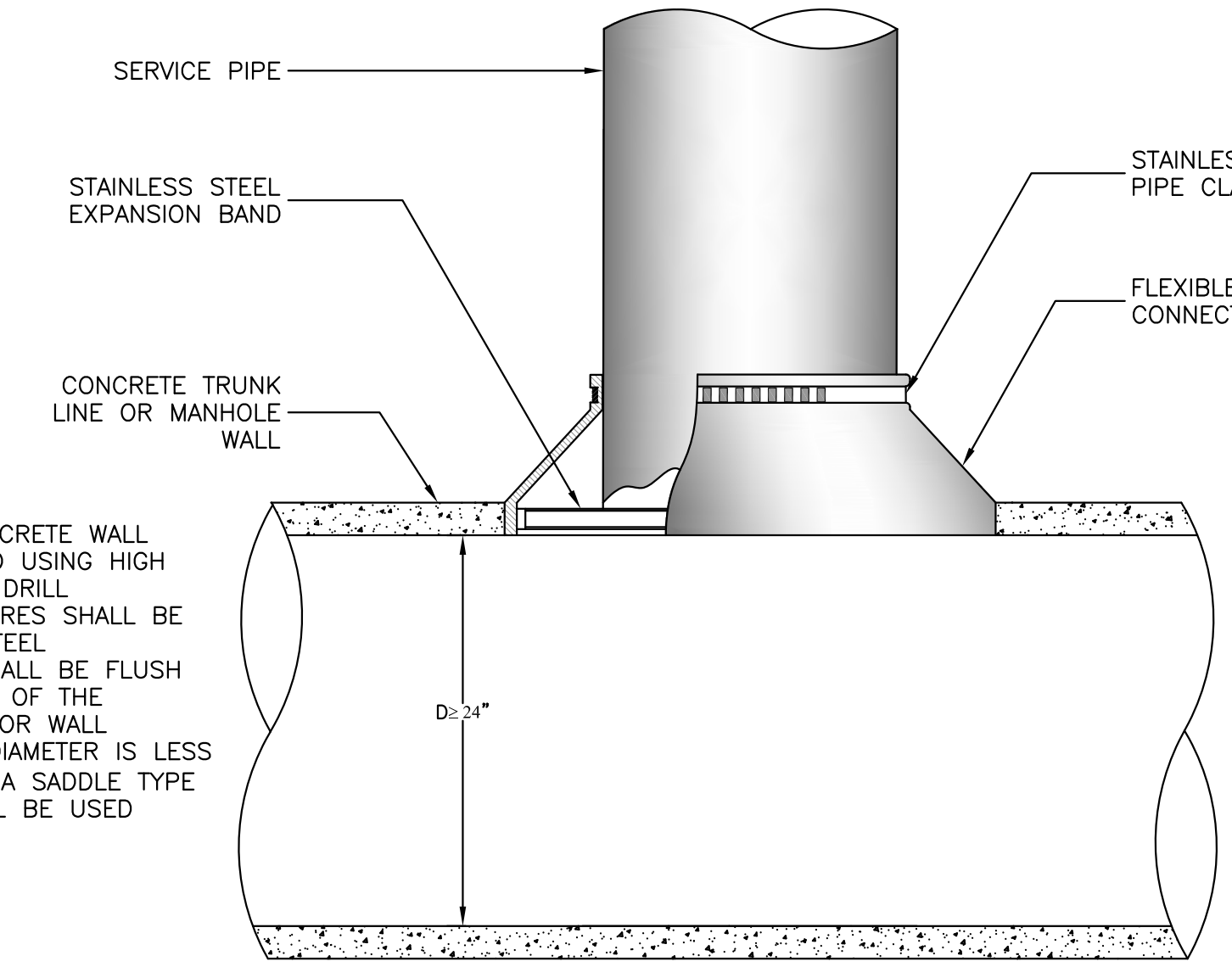

2 FIELD CONNECTION TO LARGE CONCRETE PIPE - BWSC DETAIL B-05
NOT TO SCALE

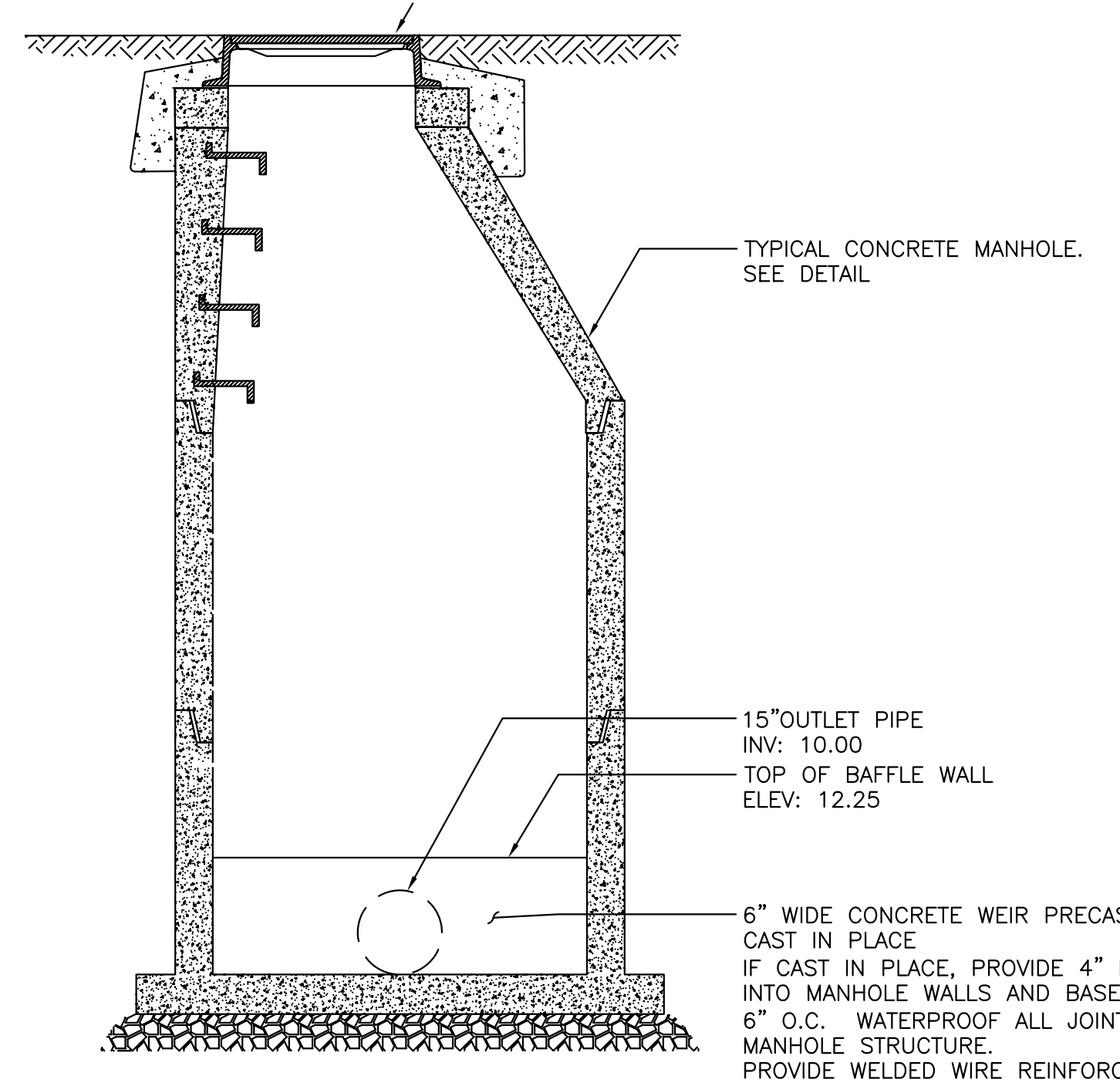

5 OUTLET CONTROL STRUCTURE
NOT TO SCALE

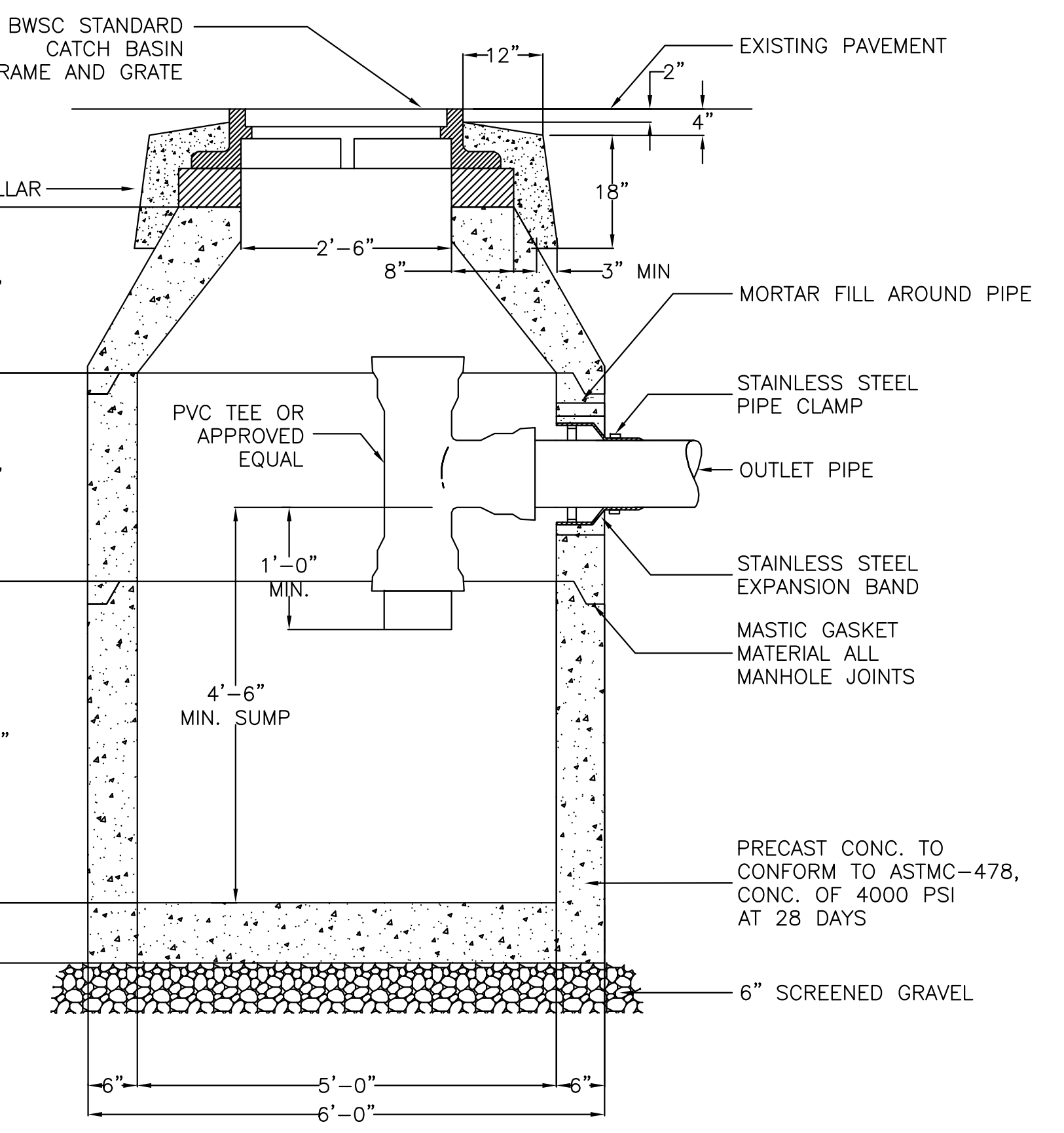

4 TYPICAL CATCH BASIN - BWSC DETAIL B-01g
NOT TO SCALE

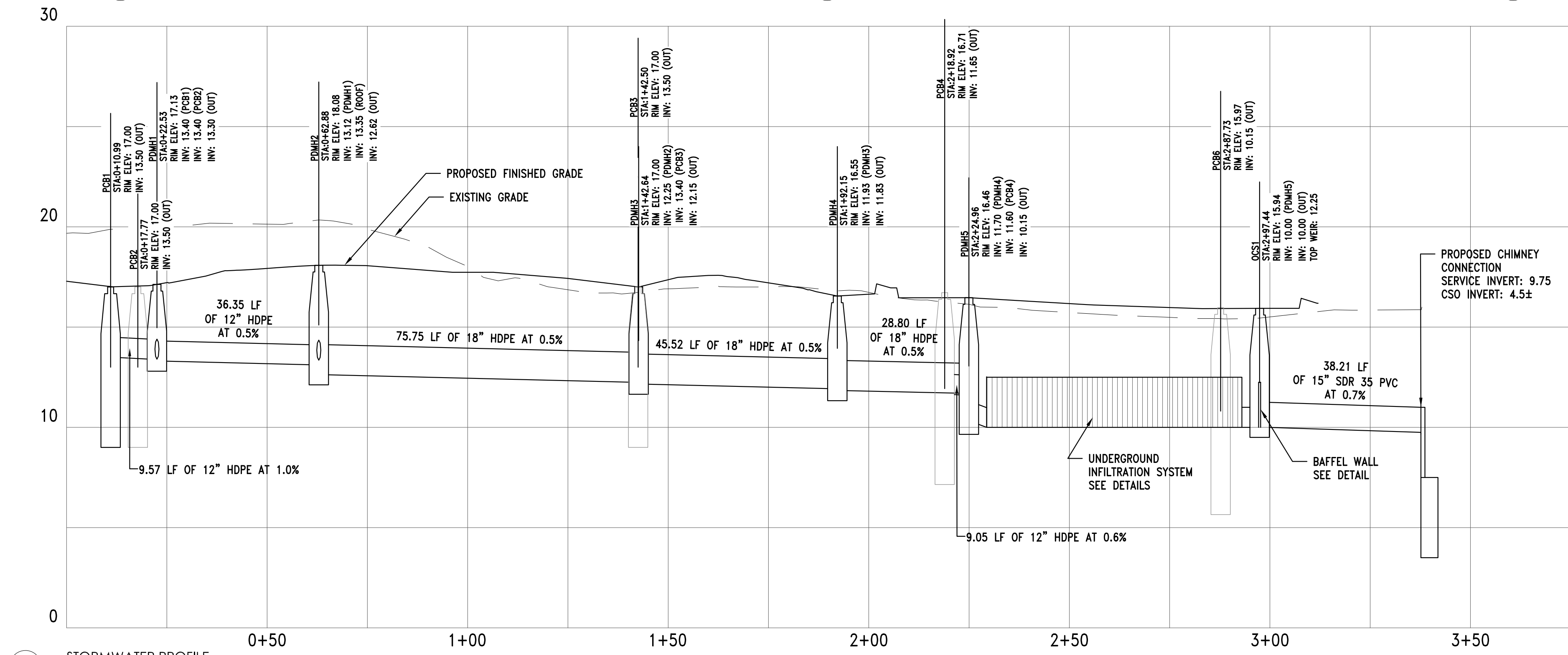

6 STORMWATER PROFILE
H: 1"=20' V: 1"=4'

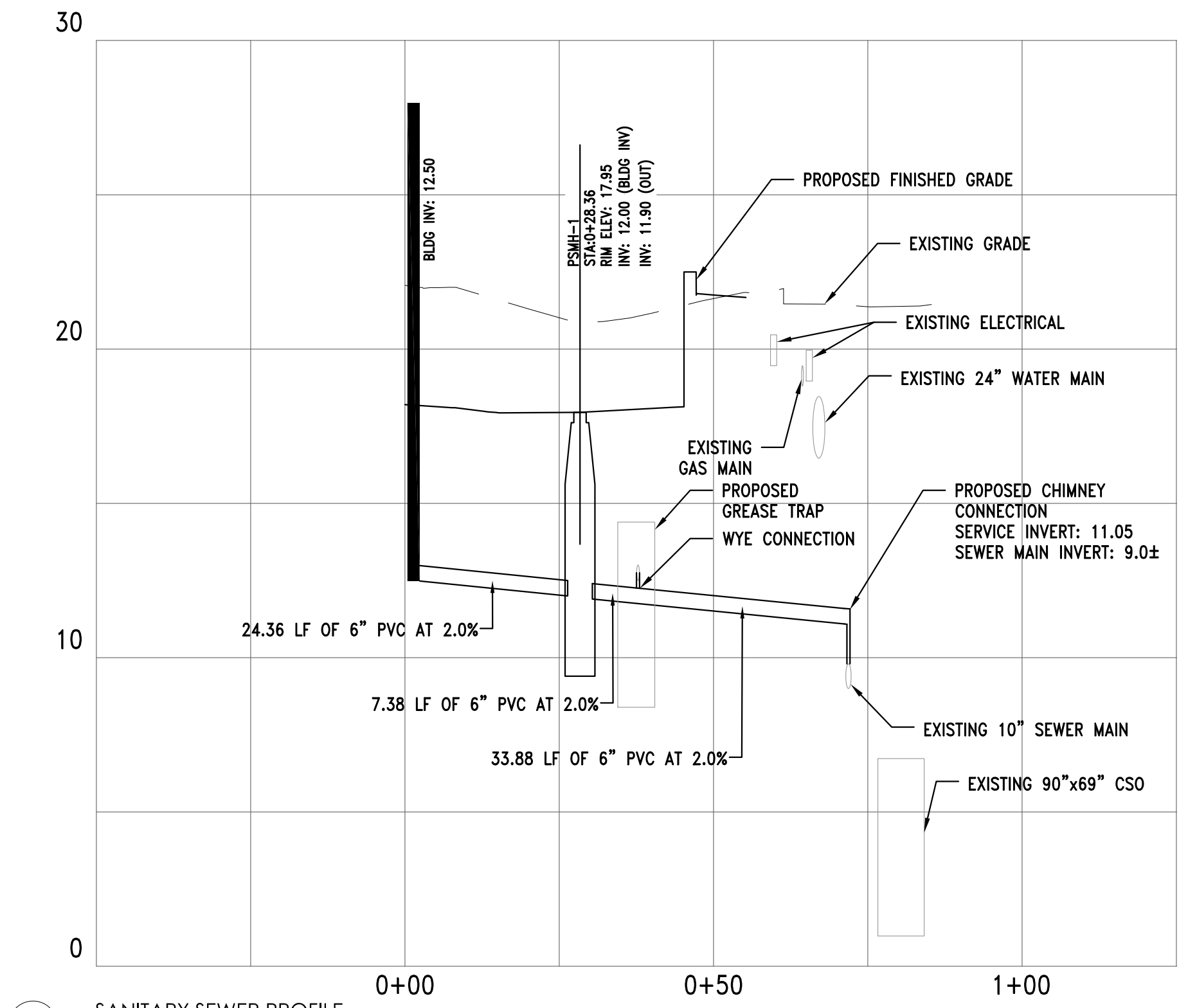

7 SANITARY SEWER PROFILE
H: 1"=20' V: 1"=4'

CIVIL ENGINEER: **PVI SITE DESIGN**
PVI Site Design, LLC
Civil Engineering - Land Enhancements
Master Planning - Project Management
397-206-1030

PROJECT: **HOTEL REDEVELOPMENT**
155 PORTER STREET, EAST BOSTON, MA
CLIENT/APPLICANT: **HUDSON 62 REALTY LLC**
440 BEDFORD ST, LEXINGTON, MA 01824

REV: 1: 12-13-2017 BWSO COMMENTS
2: 02-08-2018 BWSO COMMENTS
3: 03-07-2018 BWSO COMMENTS
4: 04-19-2018 95% OWNER'S REVIEW
5: 07-06-2018 100% ISSUED FOR CONST.
6: 09-17-2019 BPDQA COMMENTS
7: 11-26-2019 BPDQA COMMENTS

SEAL: **TIMOTHY J. POWER**
CIVIL
No. 46808
Professional Engineer
COMMONWEALTH OF MASSACHUSETTS

ISSUED FOR CONSTRUCTION
DECEMBER 8, 2017

PROFILES & DETAILS
BWSO SITE PLAN #17410

SCALE: 1"=20'
JOB NO: 003-003
FILE: 003-003-PROF.dwg
DRAWN: TJP
CHECKED: TJP
SHEET NO: **C201**

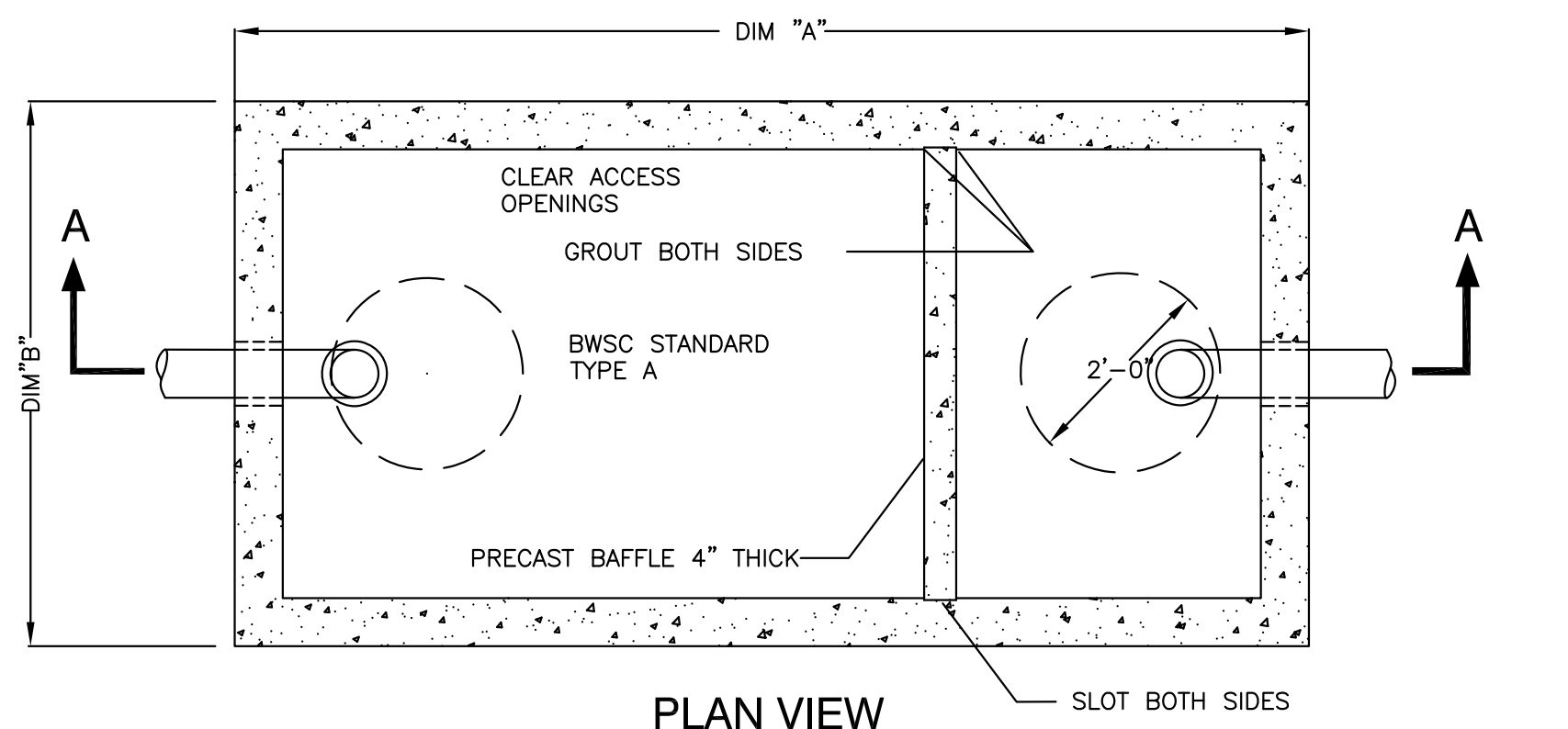

PLAN VIEW

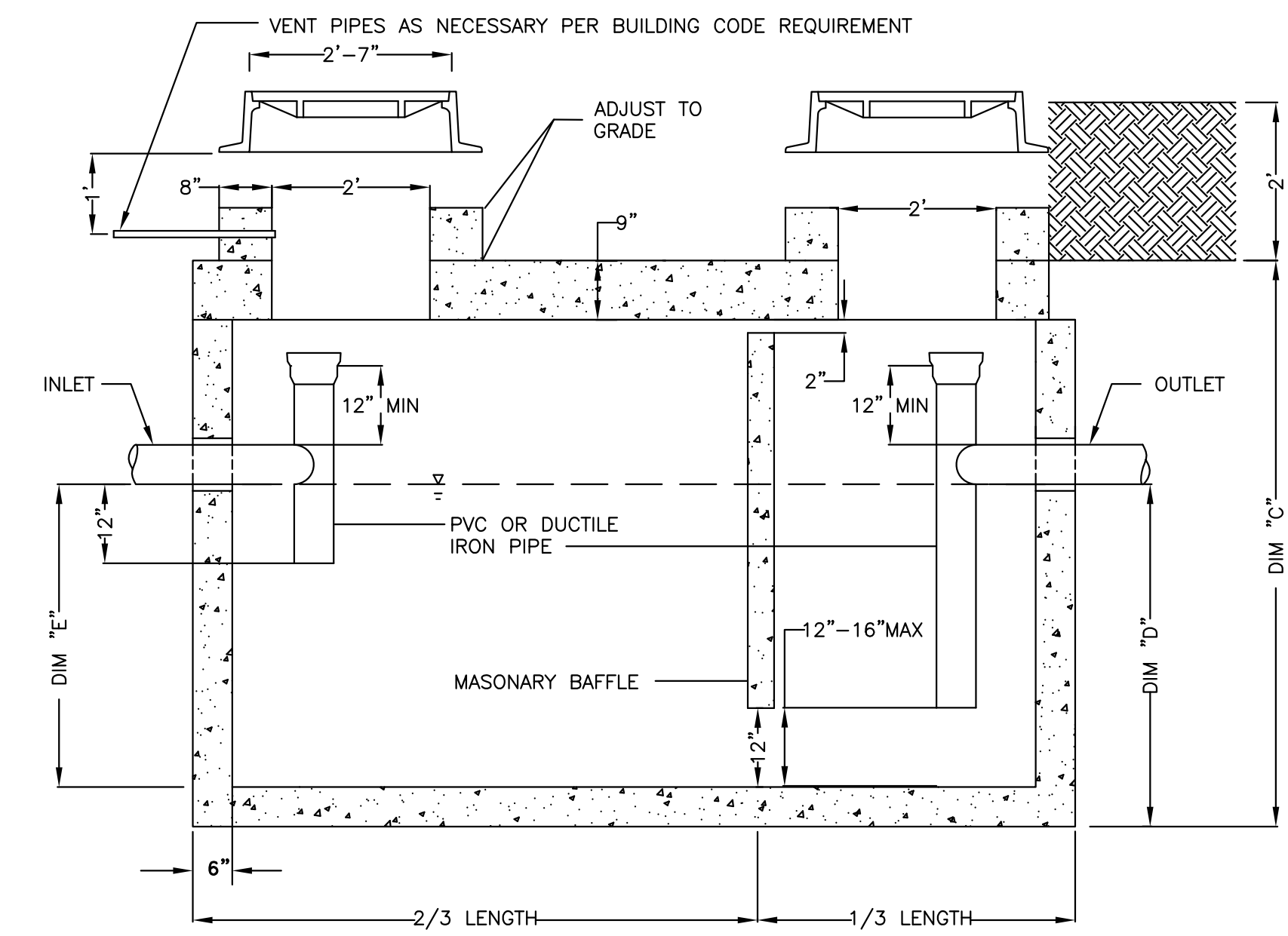

SECTION AA

- NOTES:
1. CONCRETE: 28 DAY F'c= 4500 psi
 2. REBAR: ASTM A615 GRADE 60.
 3. MESH: ASTM A-185 GRADE 65
 4. DESIGN: AC1318-83 BUILDING CODE
ASTM C-857 MINIMUM STRUCTURAL DESIGN
LOADING FOR UNDERGROUND PRECAST CONCRETE
UTILITY STRUCTURES
 5. LOADS: H-20 LOADING.
 6. FILL w/CLEAN WATER PRIOR TO START UP OF SYSTEM
 7. CONTRACTOR TO SUPPLY AND INSTALL ALL PIPING AND SANITARY
TEES ,4 CLEANOUTS, FOR CLEANING TOWARD TRAP AND FOR
CLEANING AWAY FROM TRAP ON BOTH THE INLET AND
OUTLET/ALT. DUAL SWEEP CLEANOUTS
 8. GRAY WATER ONLY, BLACK WATER SHALL BE CARRIED BY
SEPARATE SEWER.
 9. LARGER SIZES MAY BE REQUIRED AS PER REVIEW OF FACILITY.
 10. TRAP SIZE WILL BE BASED ON 15 GPD PER SEAT.

1 GREASE TRAP
NOT TO SCALE

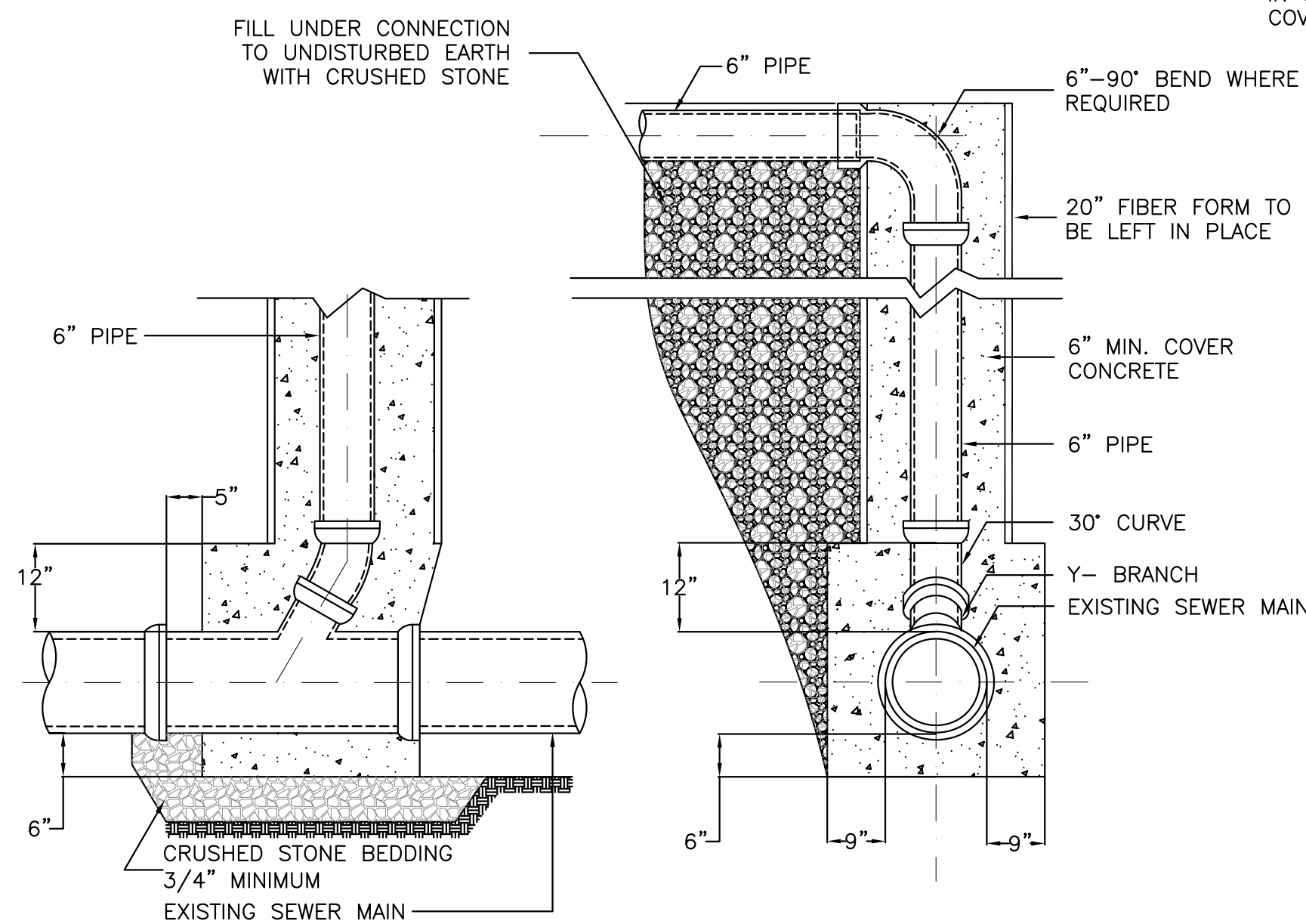

5 CHIMNEY CONNECTION
NOT TO SCALE

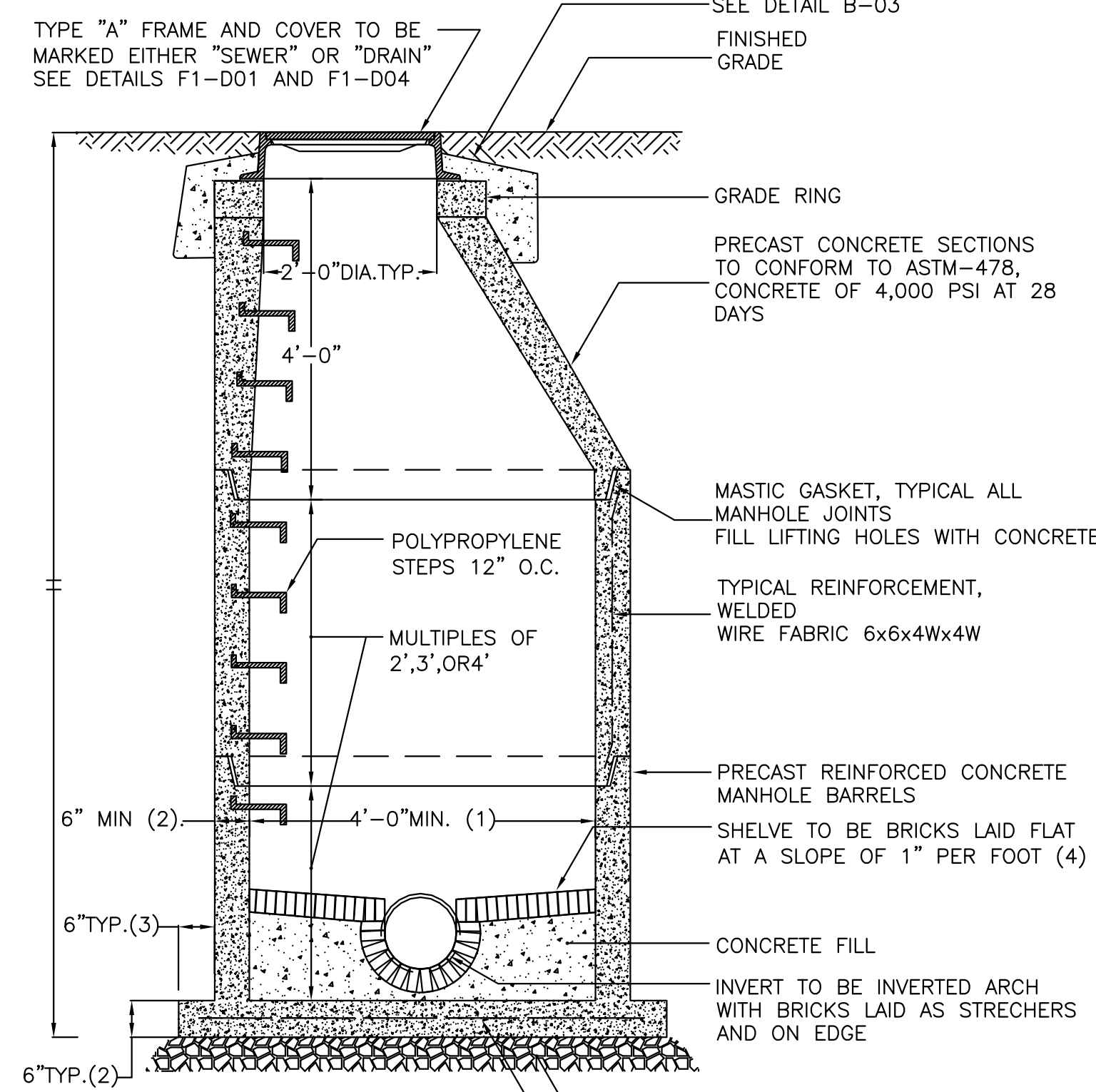

- NOTES:
1. 5'-0" DIAMETER FOR ALL MANHOLE DEPTHS
GREATER THAN 20 FEET OR WHEN ORDERED BY
THE ENGINEER
 2. 6" MIN. WALL THICKNESS AND 7 INCH MIN. BASE
THICKNESS WITH 5'-0" DIAMETER MANHOLES
 3. 6 INCH LIP OPTIONAL UNLESS OTHERWISE NOTED
 4. CONCRETE INVERT AND SHELF MAY BE
SUBSTITUTED IN STORM DRAIN MANHOLES AS
DIRECTED BY THE ENGINEER

2 CONCRETE MAHOLE
NOT TO SCALE

- NOTES:
1. ALL CAST IN PLACE CONCRETE TO HAVE A MINIMUM 28 DAY STRENGTH OF 3000 LBS
PER SQ. INCH, USING 3/4" MAXIMUM SIZE AGGREGATE
 2. REINFORCING STEEL BARS ARE DEFORMED BARS OF BILLET STEEL ASTM A615 GRADE
60
 3. WELDED WIRE FABRIC CONFORMS TO ASTM A185
 4. CAST IRON FRAME, TYPE "A" AND COVER TYPE "A" FOR DETAILS SEE DETAILS NOS.
F1-D01, F1-D04 AND F1-D05 COVERS TO BE MARKED EITHER "SEWER" OR "DRAIN".
 5. DESIGN LIVE LOAD - HS 20 - 44
 6. MINIMUM COVER FOR REINFORCING IN WALLS OR SLABS POURED AGAINST EARTH SHALL
BE 3 INCHES. ALL OTHERS SHALL BE 2 INCHES UNLESS OTHERWISE NOTED
 7. USE 2'-0" LENGTHS OF PIPE STUBS AT ALL MANHOLES FOR VC OR AC PIPE. USE
4'-0" MAX. LENGTHS OF PIPE STUBS AT ALL MANHOLES FOR RC, DI OR PVC.
 8. THESE MANHOLE DETAILS TO BE USED FOR BOTH SANITARY SEWER AND STORM DRAIN
MANHOLES
 9. ALL MANHOLES SHALL BE CONSTRUCTED OF REINFORCED CONCRETE SHOP DRAWINGS
SUBMITTALS SHALL SHOW ALL REINFORCING DETAILS
 10. MWRA OIL AND GREASE SEPARATOR IS USED WITHIN BUILDINGS WHERE REQUIRED BY
MWRA (MASSACHUSETTS WATER RESOURCES AUTHORITY) OR DEP (DEPARTMENT OF
ENVIRONMENTAL PROTECTION) REGULATION. FOR DETAILS SEE DETAIL NO. B-04. FOR
BWS APPROVED GRIT AND OIL SEPARATORS, SEE DETAIL NOS. B-17 AND B-18.

3 SEWER STRUCTURE NOTES

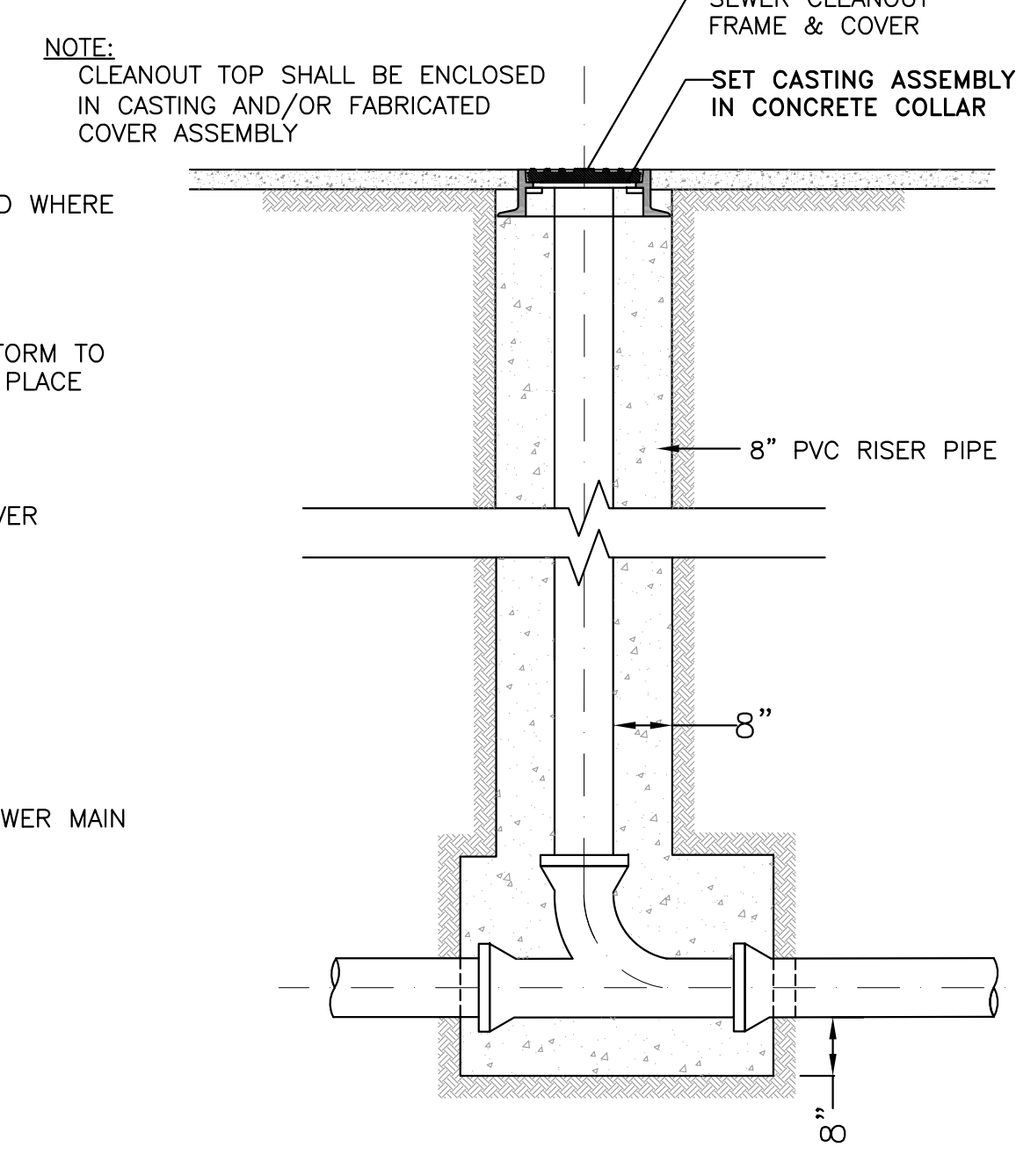

6 INLINE CLEANOUT
NOT TO SCALE

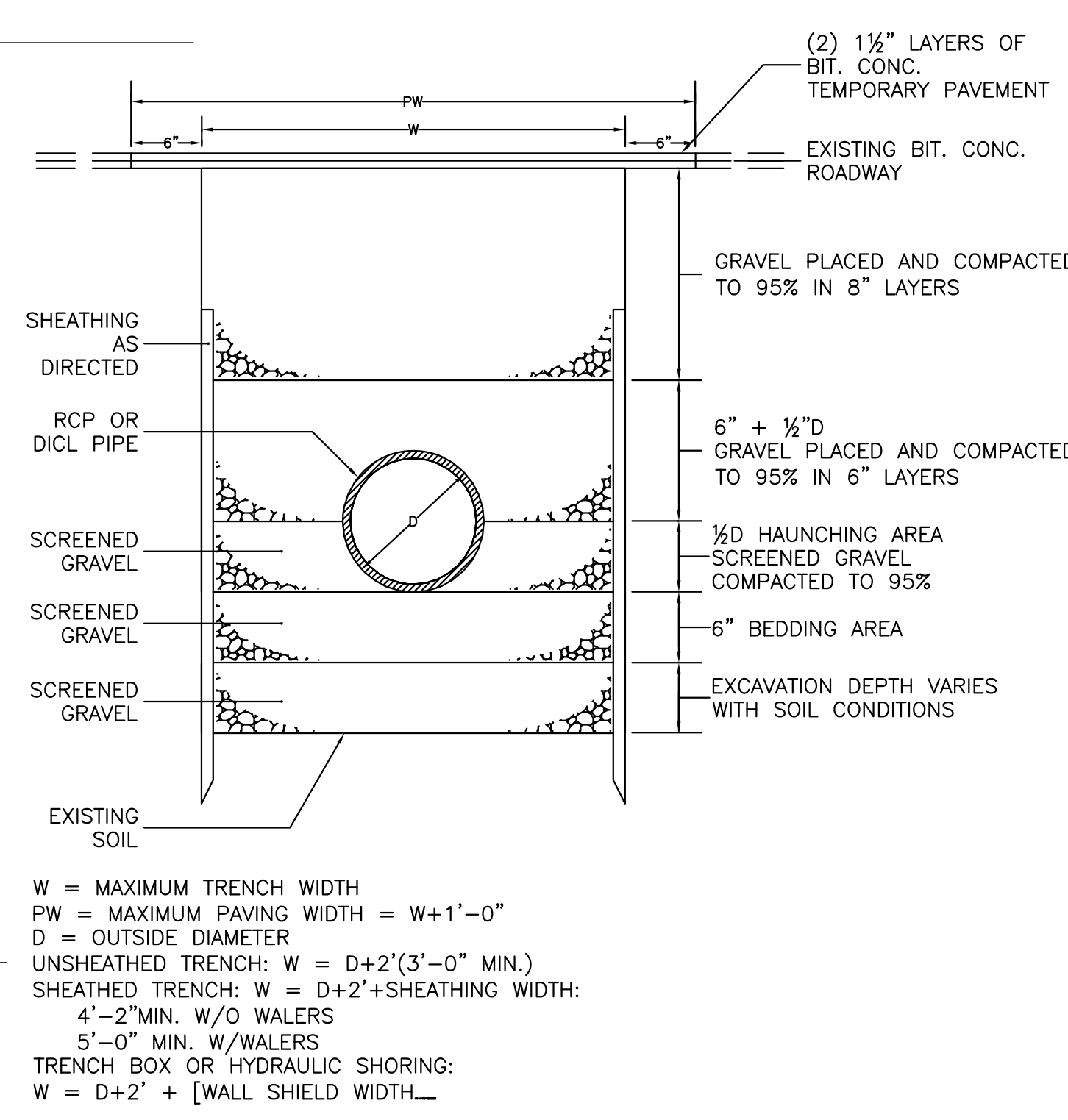

7 UTILITY TRENCH
NOT TO SCALE

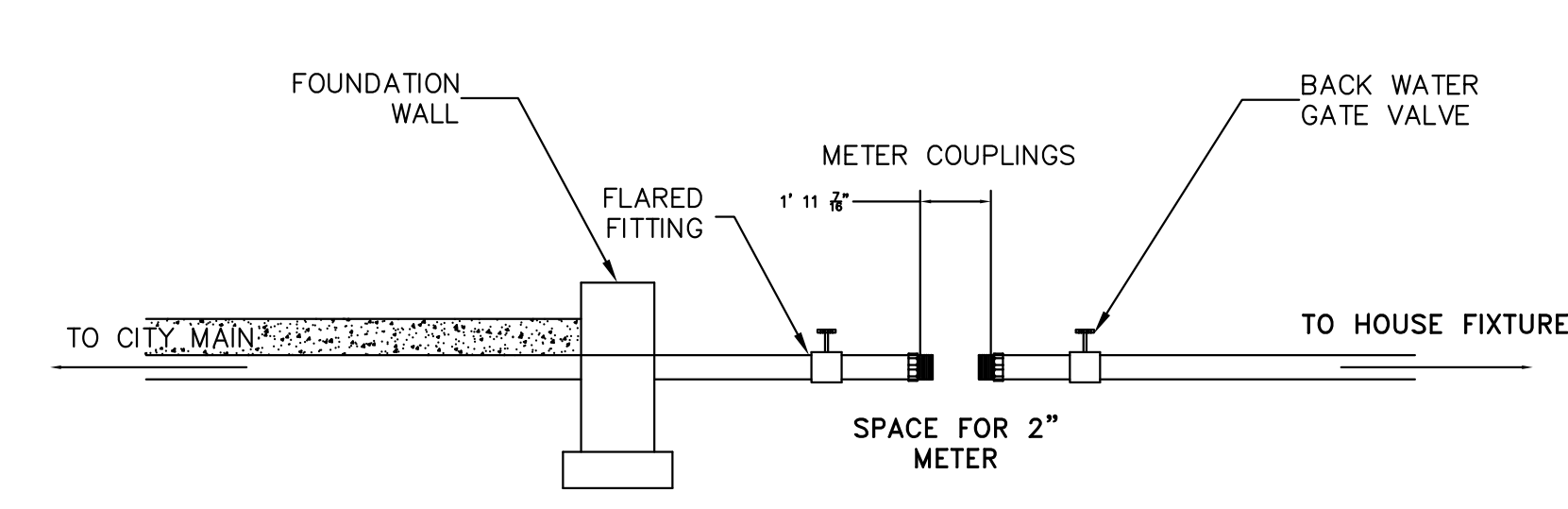

4 PLUMBING FOR 2" METER CONNECTION
NOT TO SCALE

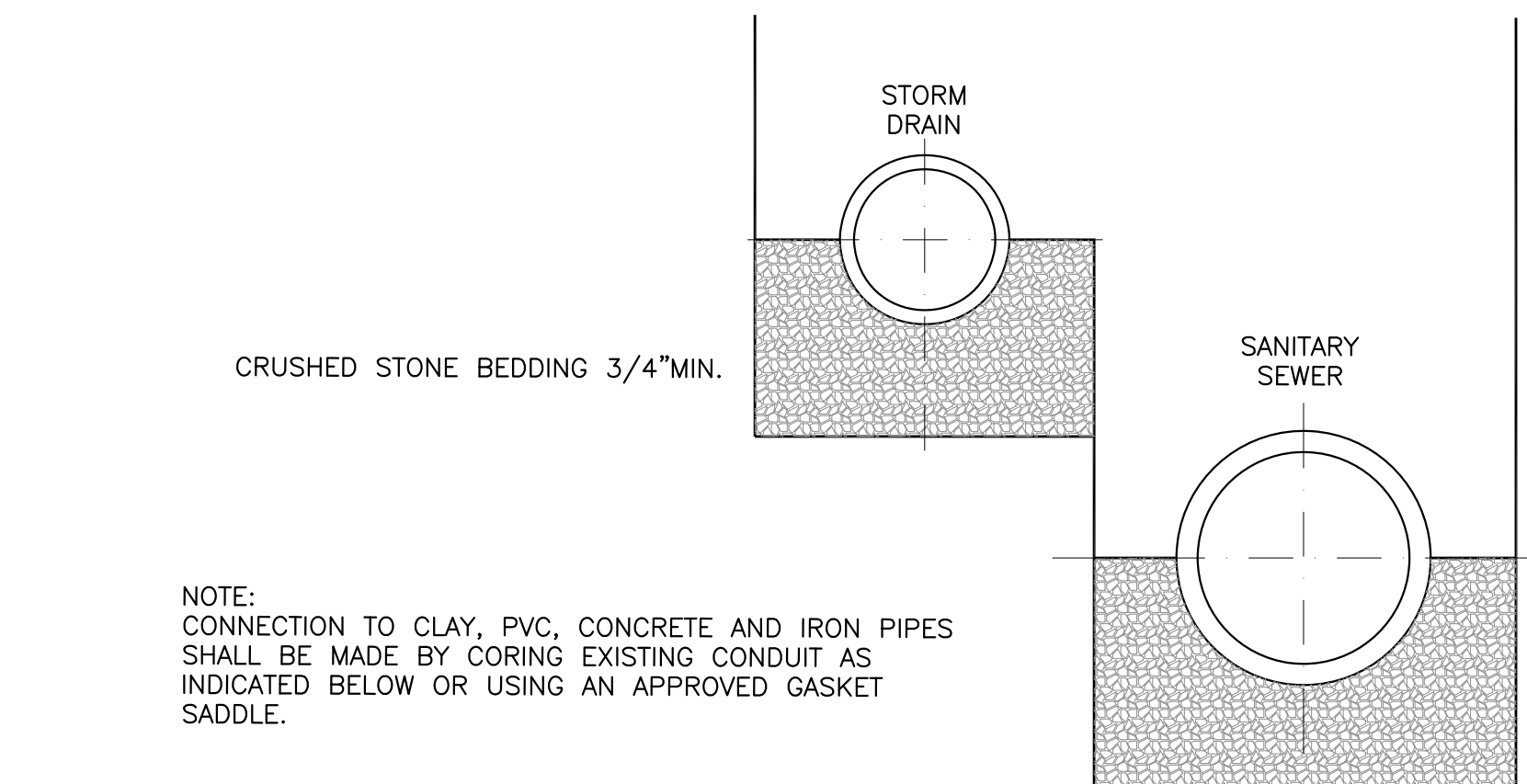

5 TYPICAL CONNECTION TO EXISTING COMBINED SEWER
NOT TO SCALE

- NOTES:
1. ALL WORK MUST BE PERFORMED BY A
BWS LICENSED AND BONDED CONTRACTOR.
 2. THIS PROCEDURE WILL INVOLVE A MAIN LINE
SHUT DOWN THAT THE CONTRACTOR WILL
COORDINATE WITH THE BWS'S OPERATIONS
DIVISION.
 3. WRITTEN NOTIFICATION OF ALL AFFECTED
CUSTOMERS MUST BE PERFORMED BY THE
CONTRACTOR.
 4. ALL WORK MUST BE PERMITTED BY BWS
AND ALL OTHER APPROPRIATE AGENCIES.
 5. ALL WORK MUST BE INSPECTED BY BWS
INSPECTOR OR DESIGNEE.

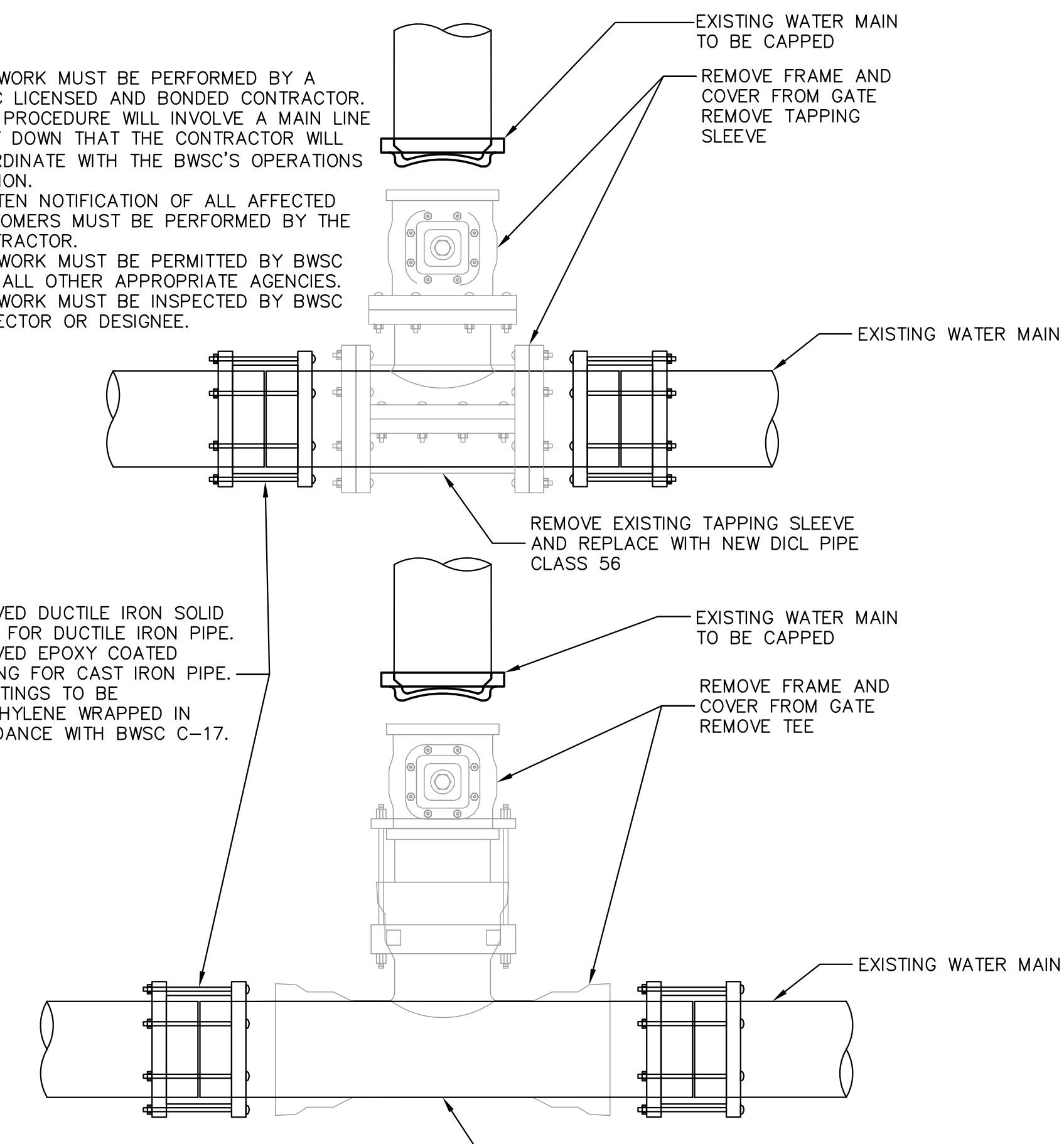

8 REMOVAL OF EXISTING WATER SERVICE
NOT TO SCALE

CIVIL ENGINEER:

PVI
SITE DESIGN
PVI Site Design, LLC
Civil Engineering - Land Enhancements
Master Planning - Project Management
337-206-1030

PROJECT:

HOTEL REDEVELOPMENT
155 PORTER STREET, EAST BOSTON, MA
HUDSON 62 REALTY LLC
440 BEDFORD ST, LEXINGTON, MA 01824

REV:

1: 12-13-2017	BWSC COMMENTS
2: 02-08-2018	BWSC COMMENTS
3: 03-07-2018	BWSC COMMENTS
4: 04-19-2018	95% OWNER'S REVIEW
5: 07-06-2018	100% ISSUED FOR CONST.
6: 09-17-2019	BPDA COMMENTS
7: 11-26-2019	BPDA COMMENTS

SEAL:

TIMOTHY J. POWER
CIVIL
No. 46898
PROFESSIONAL ENGINEER

ISSUED FOR CONSTRUCTION
DECEMBER 8, 2017

SCALE: 1"=20'

JOB NO: 003-003

FILE: 003-003-PROF.dwg

DRAWN: TJP

CHECKED: TJP

SHEET NO: C202

DETAILS

BWSC SITE PLAN #17410

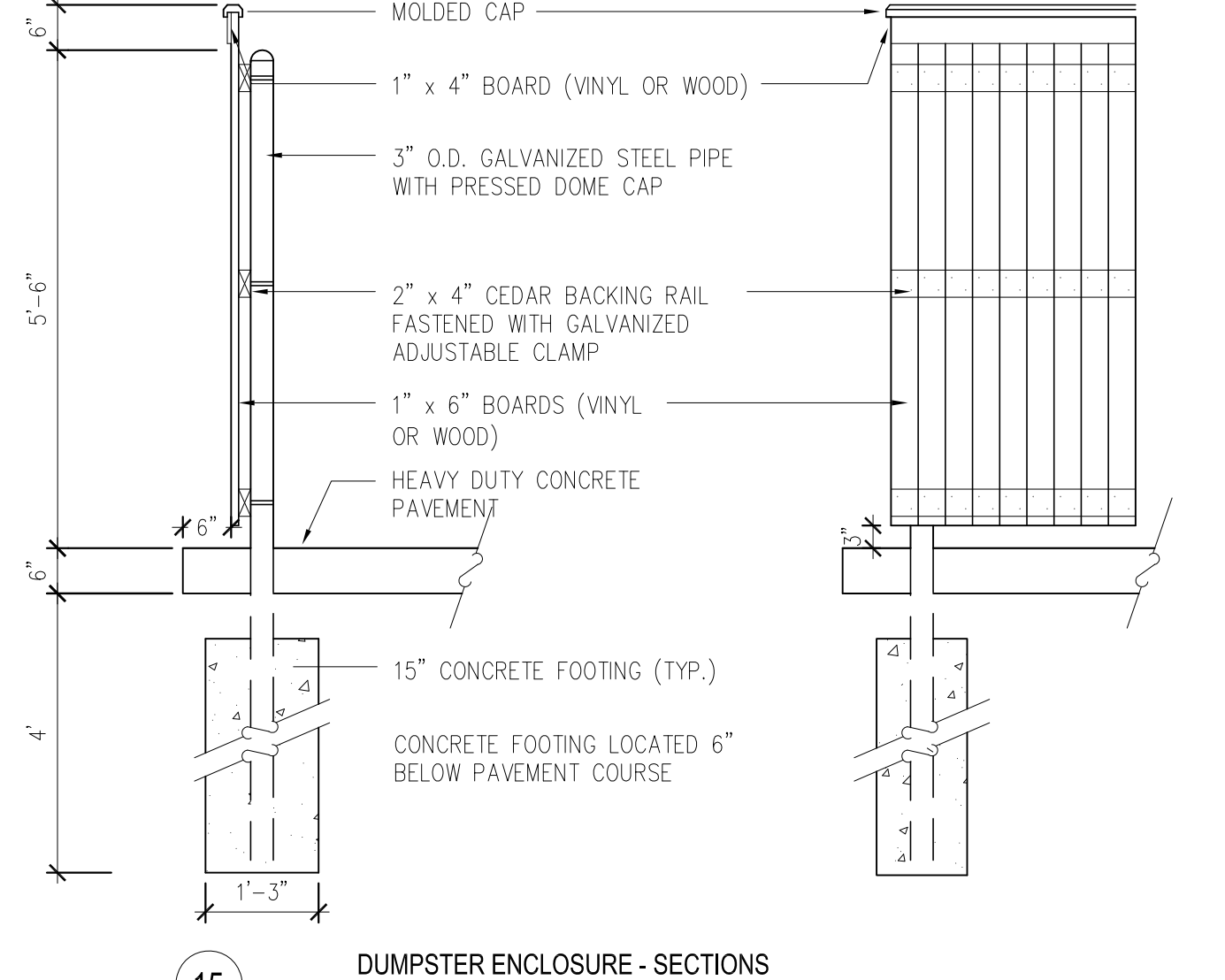
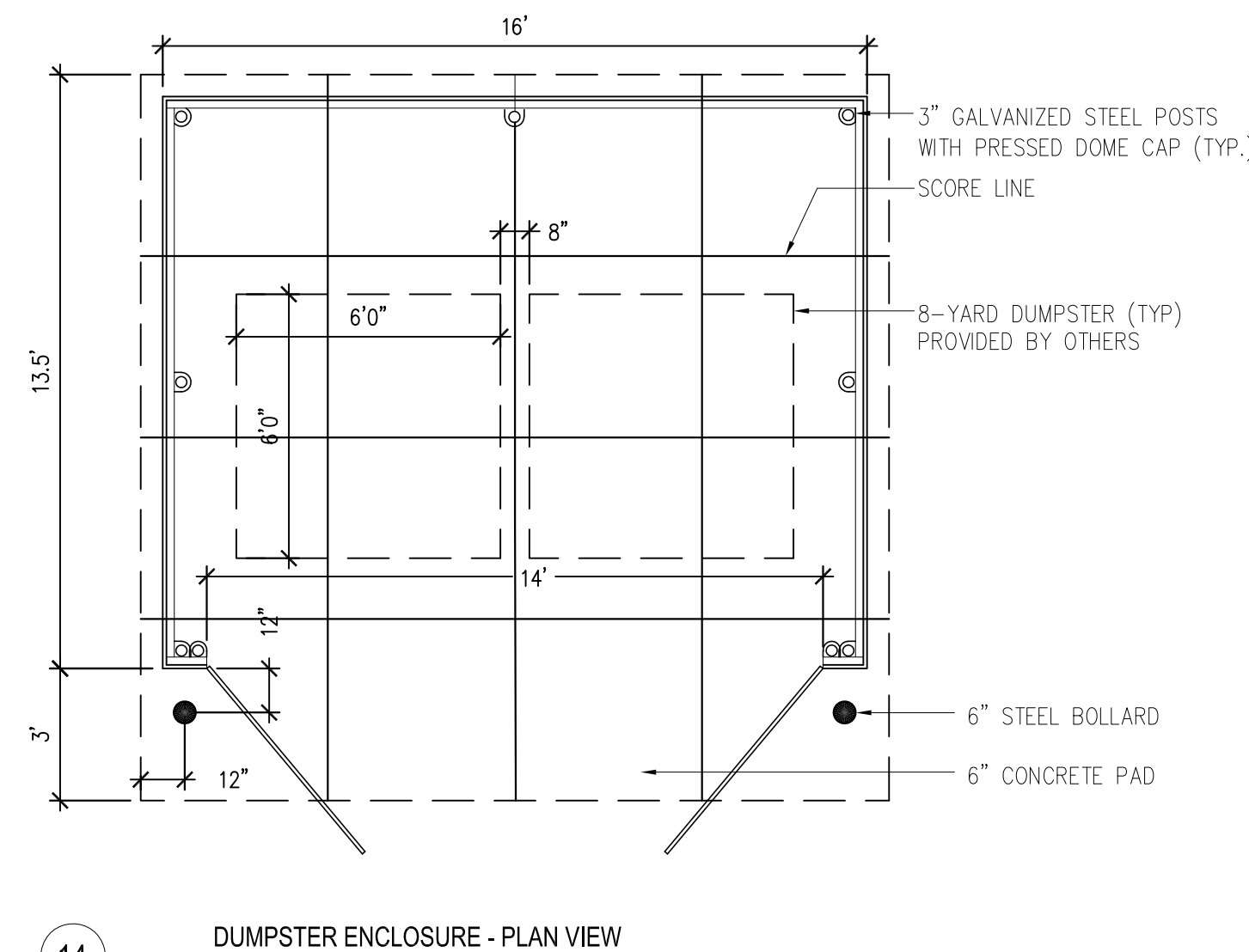
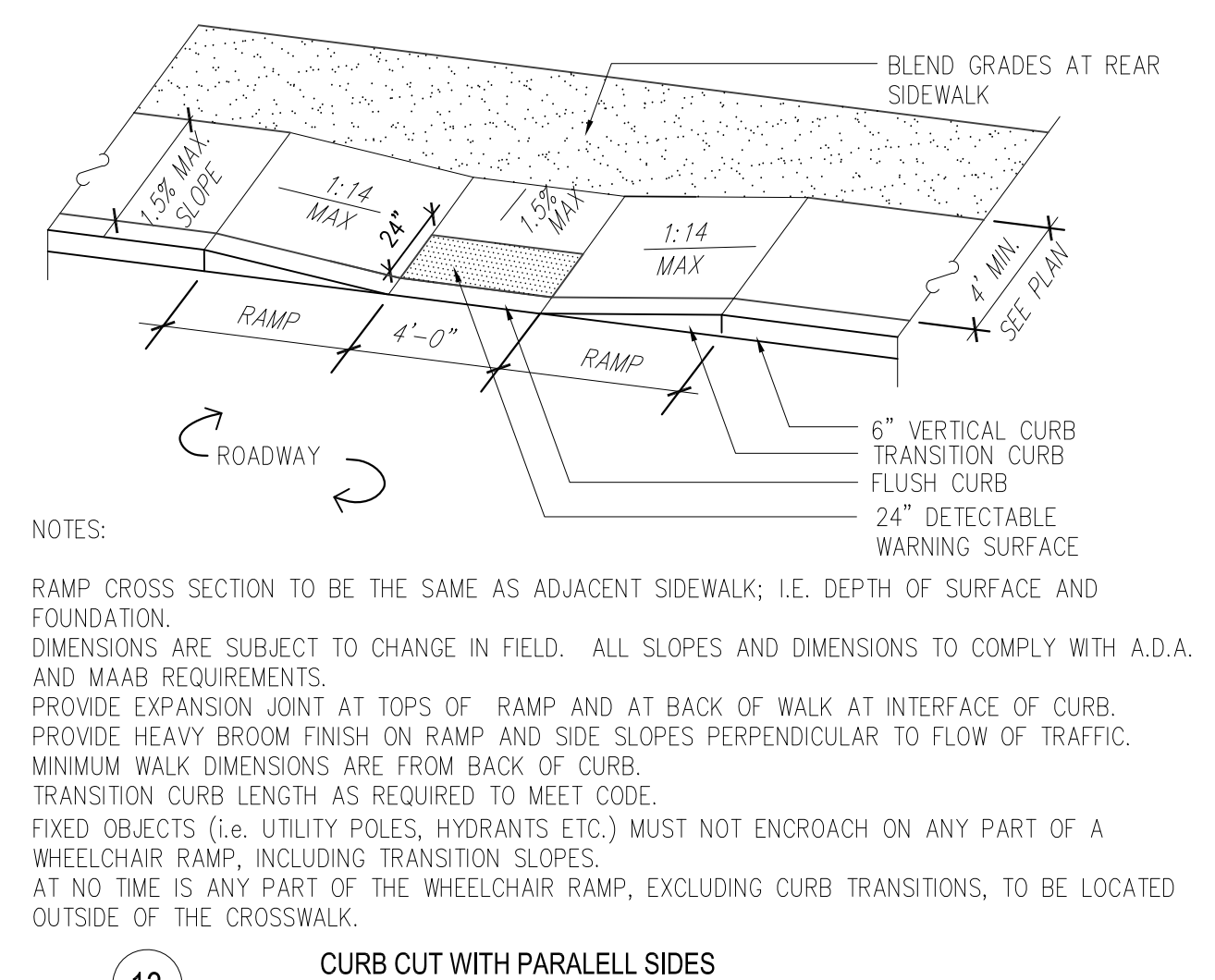
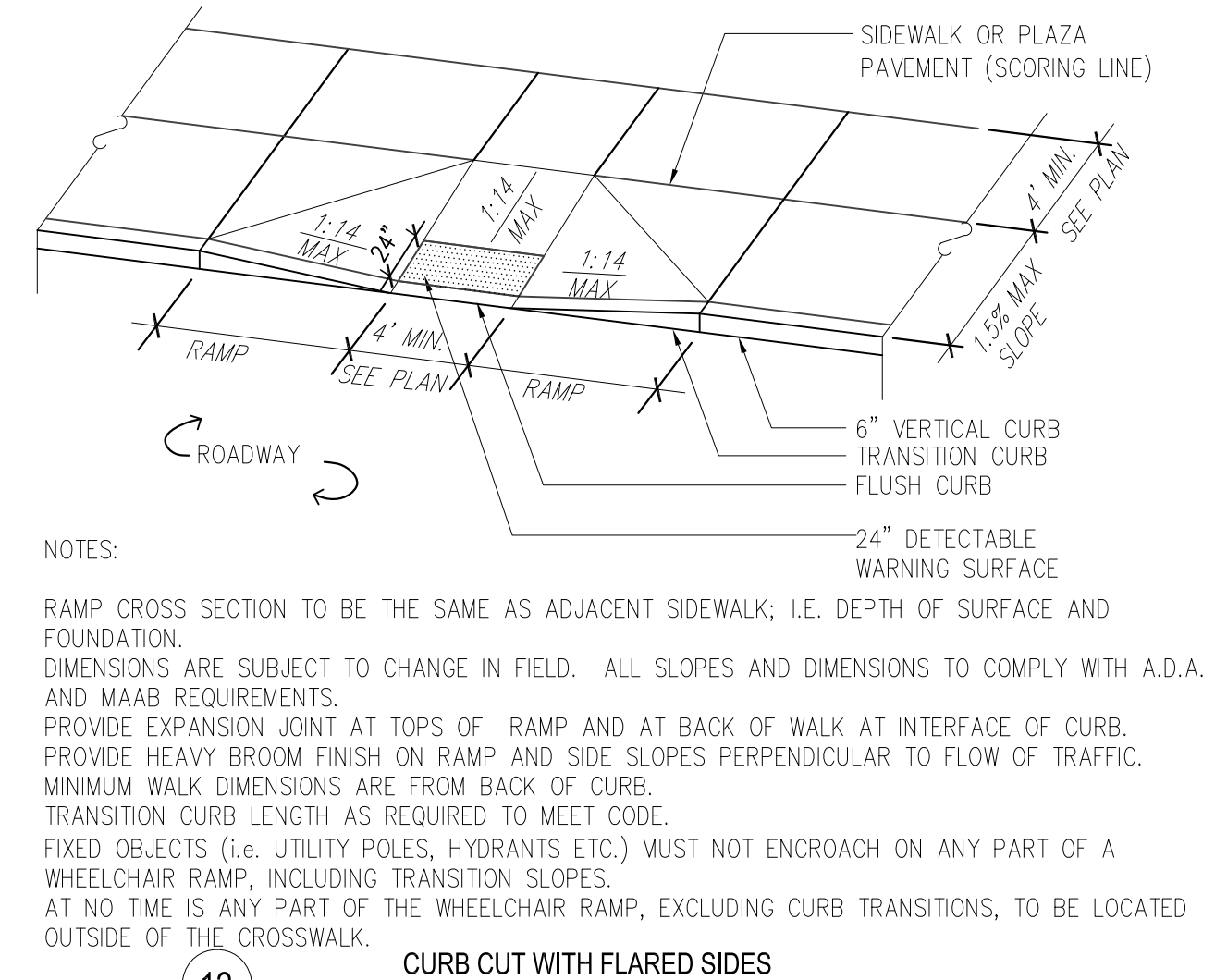
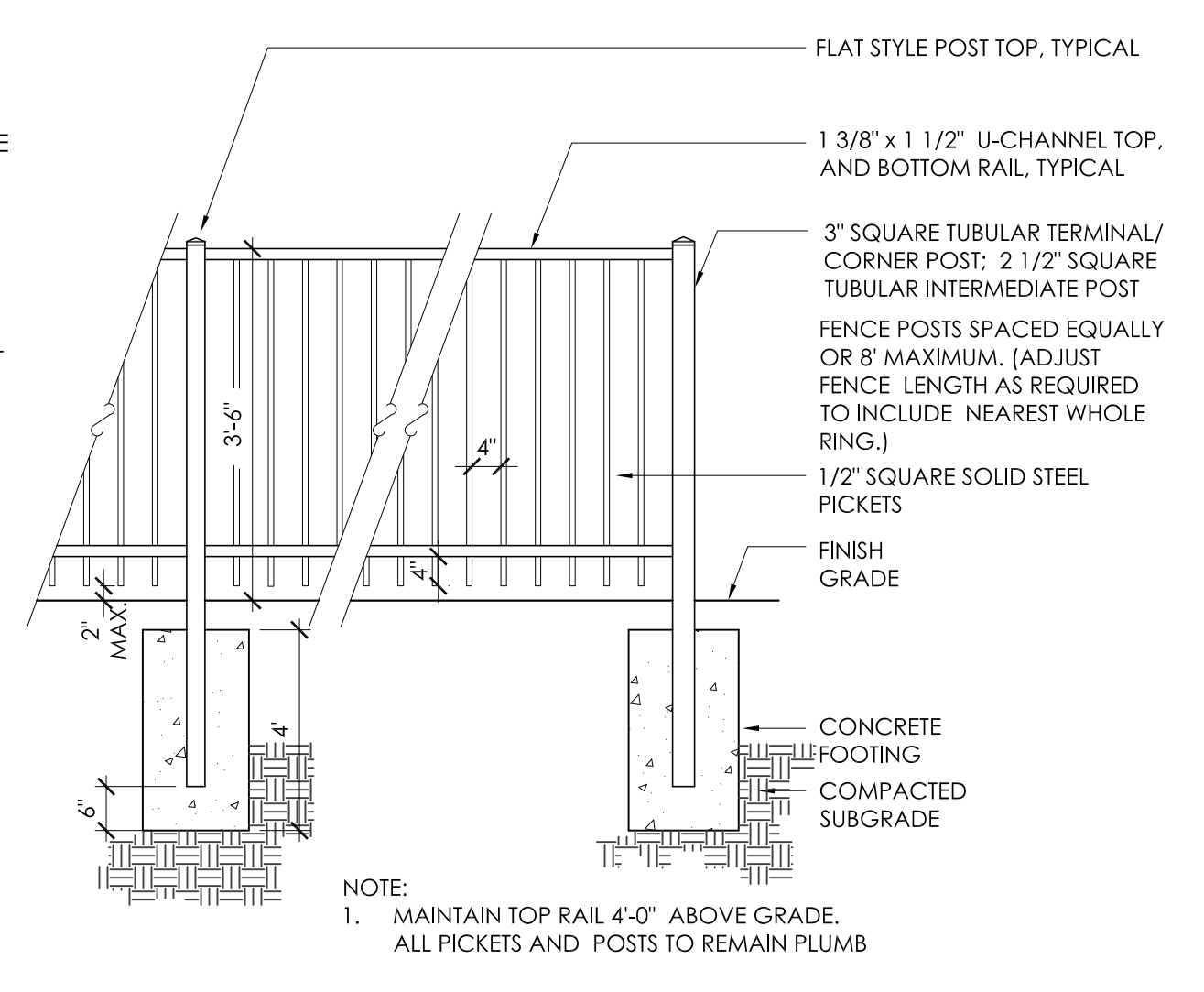
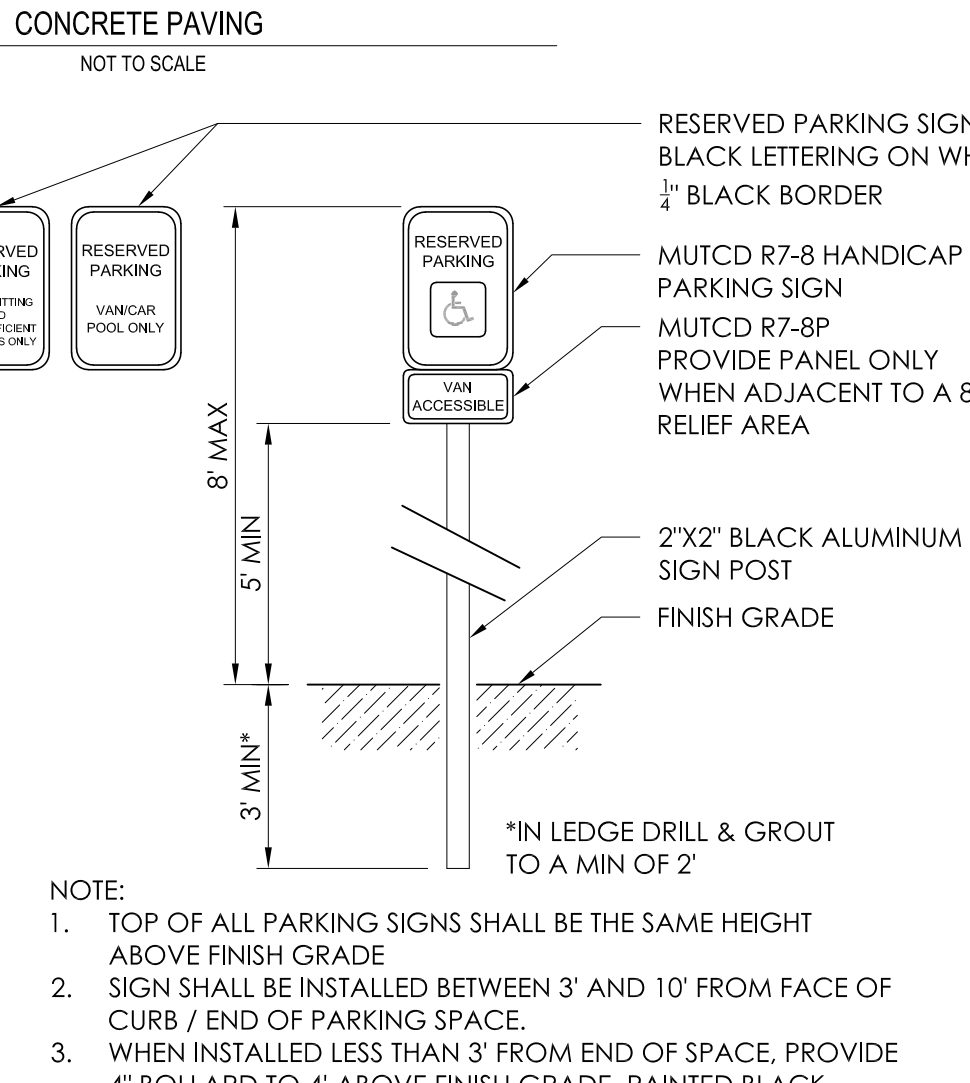
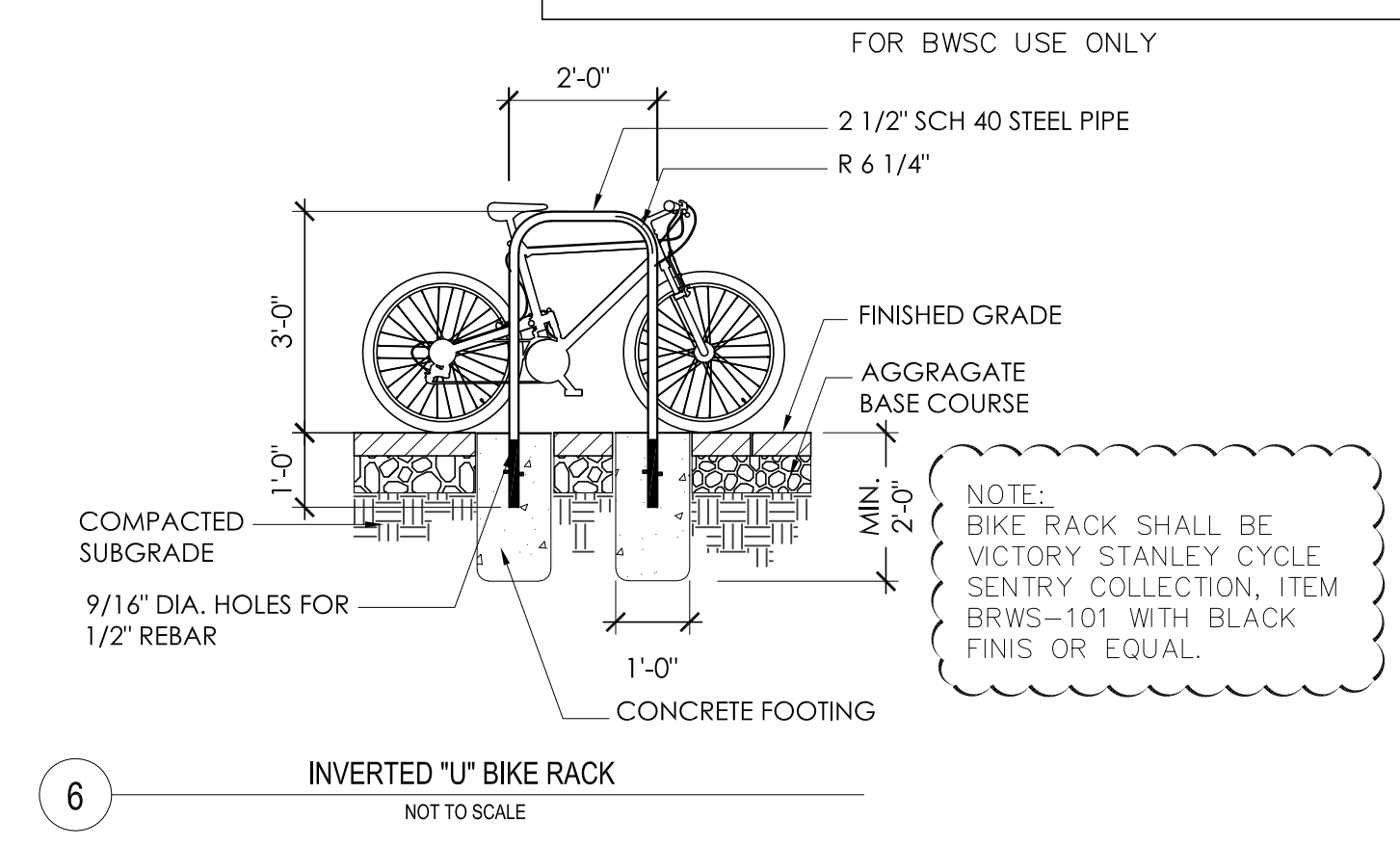
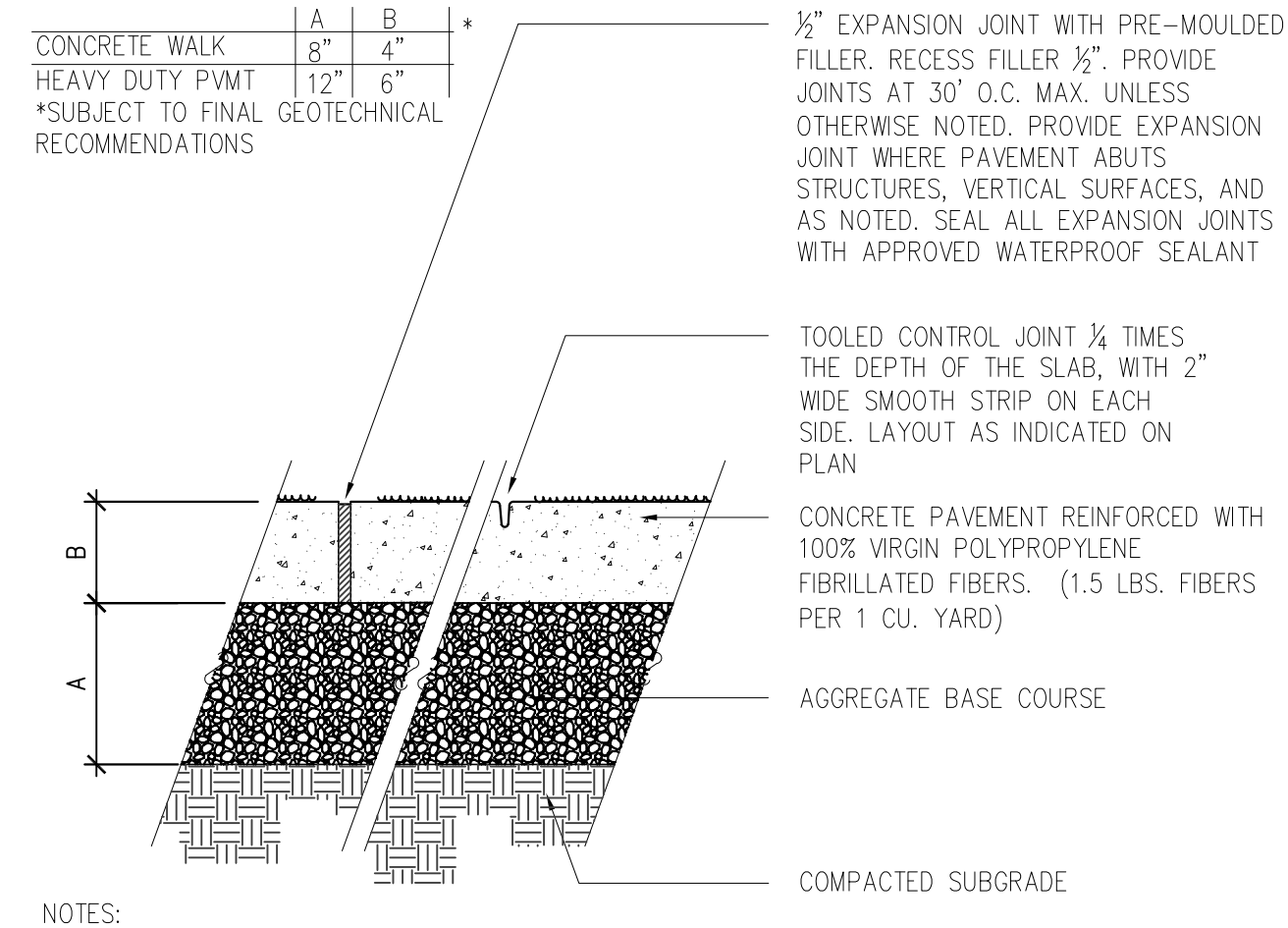
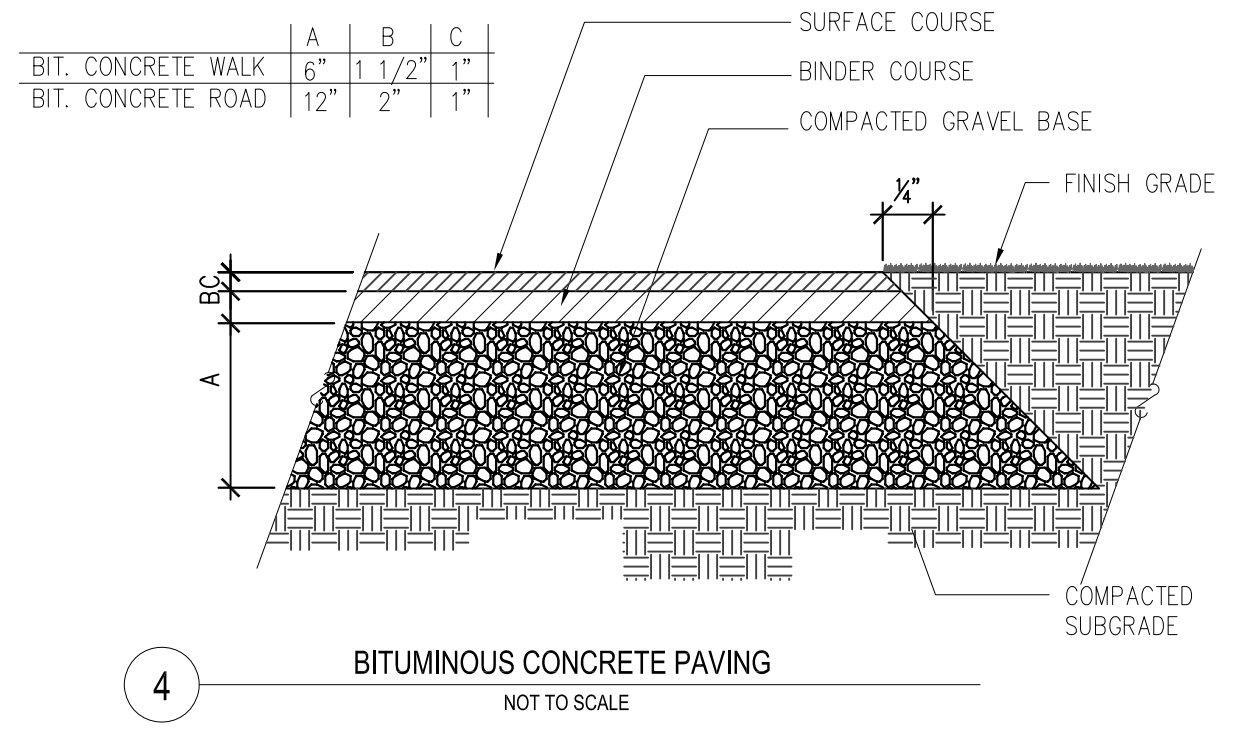
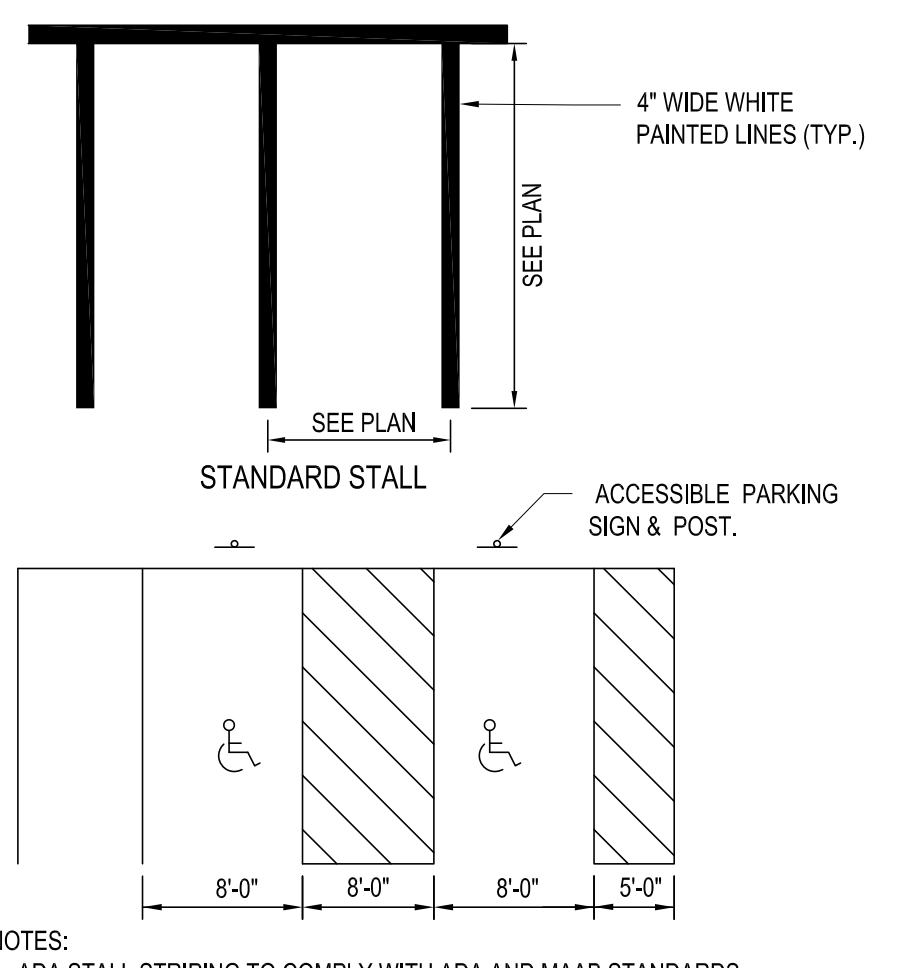
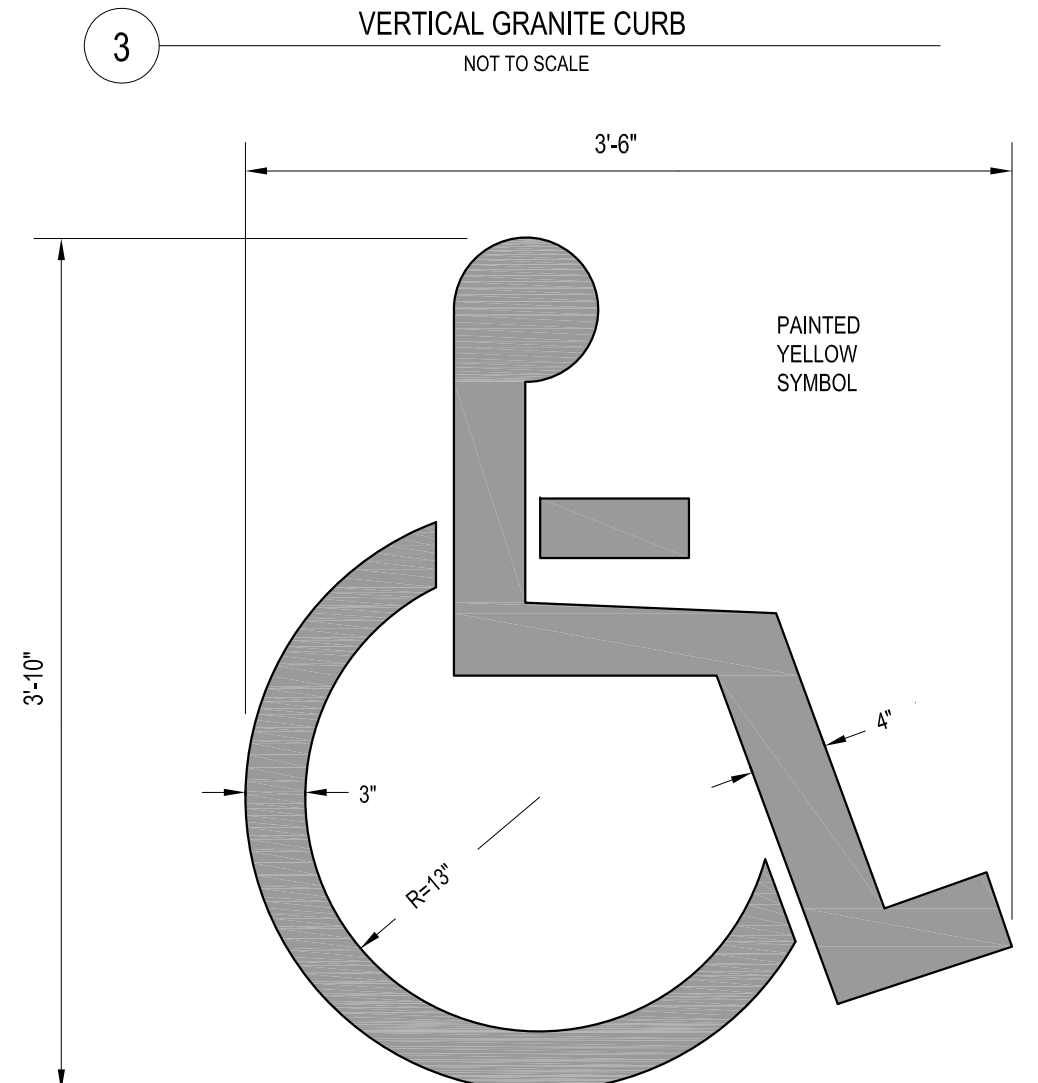
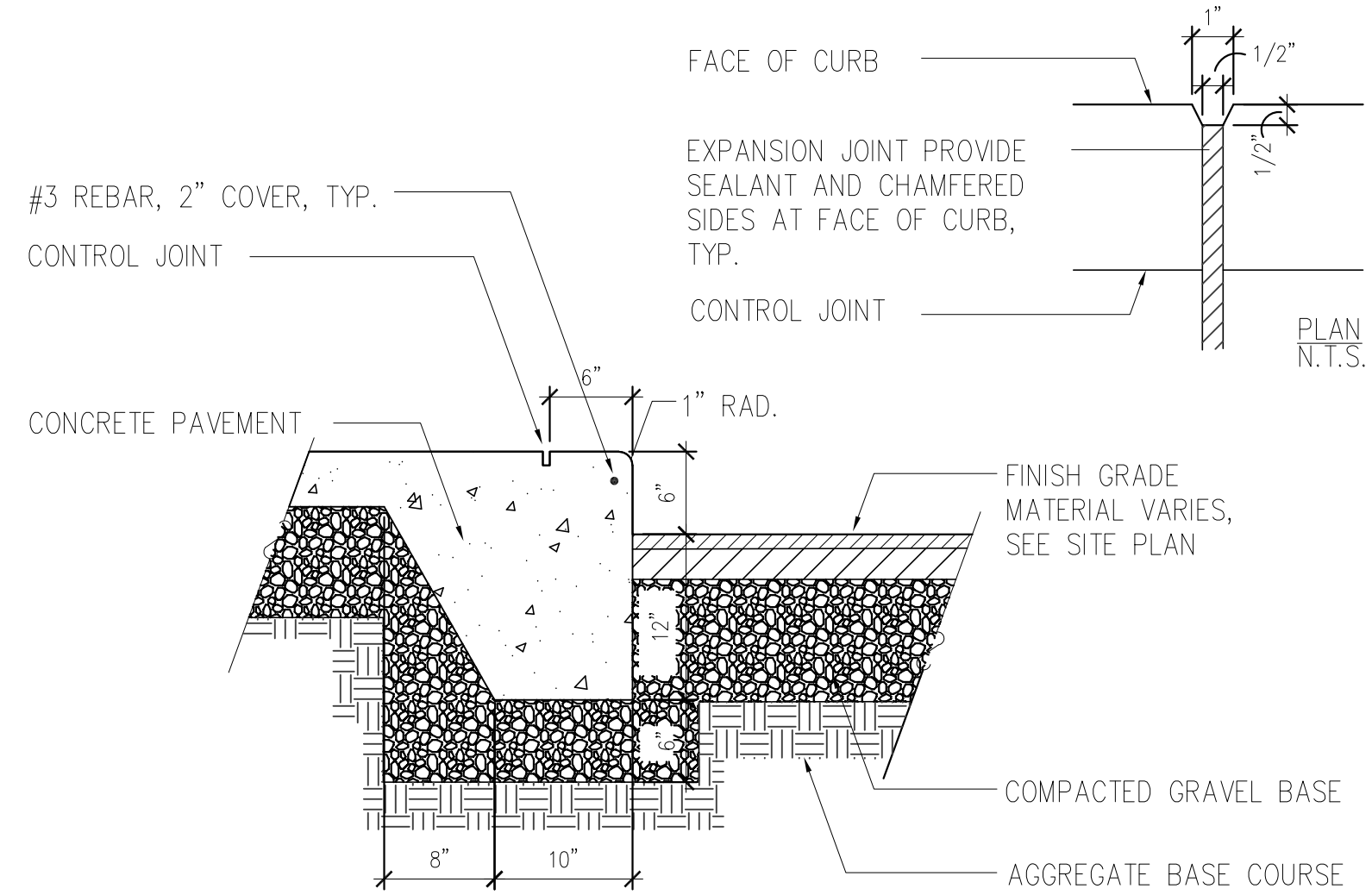
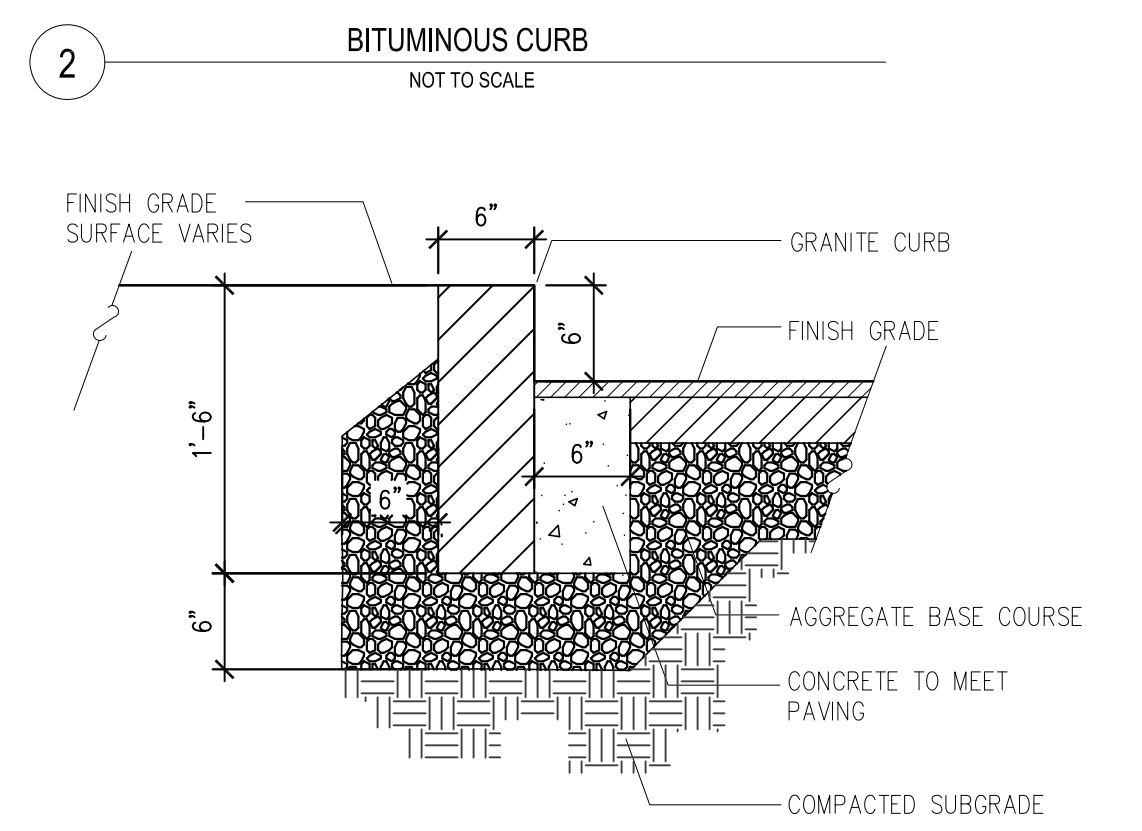
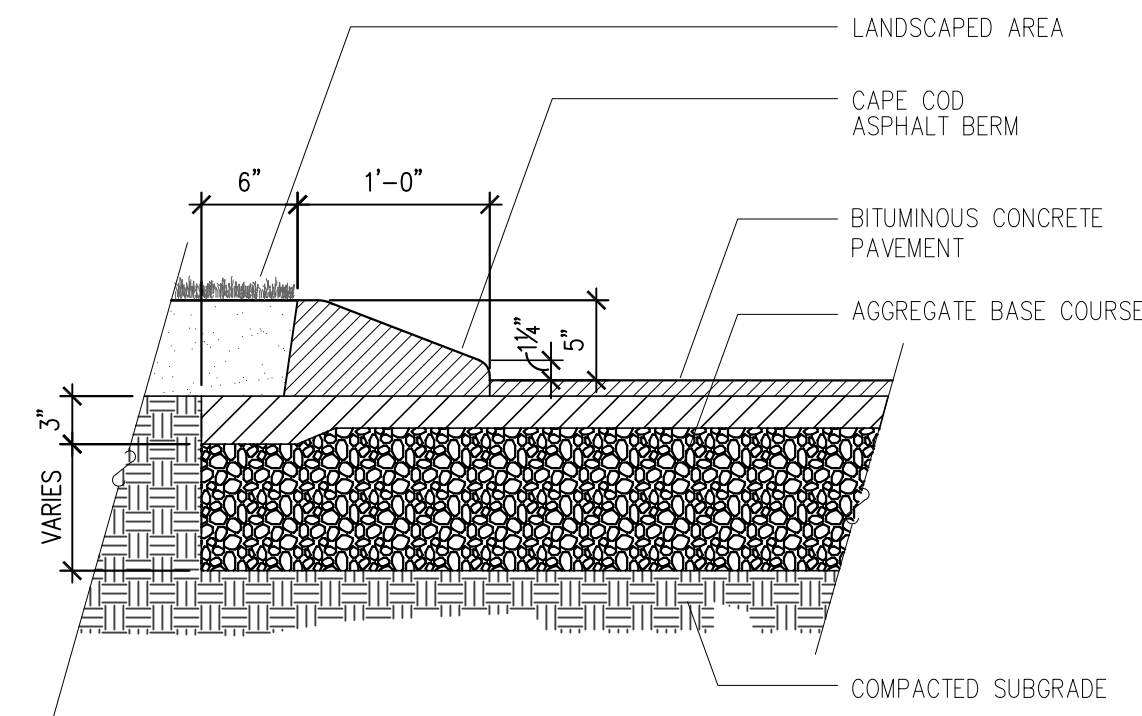
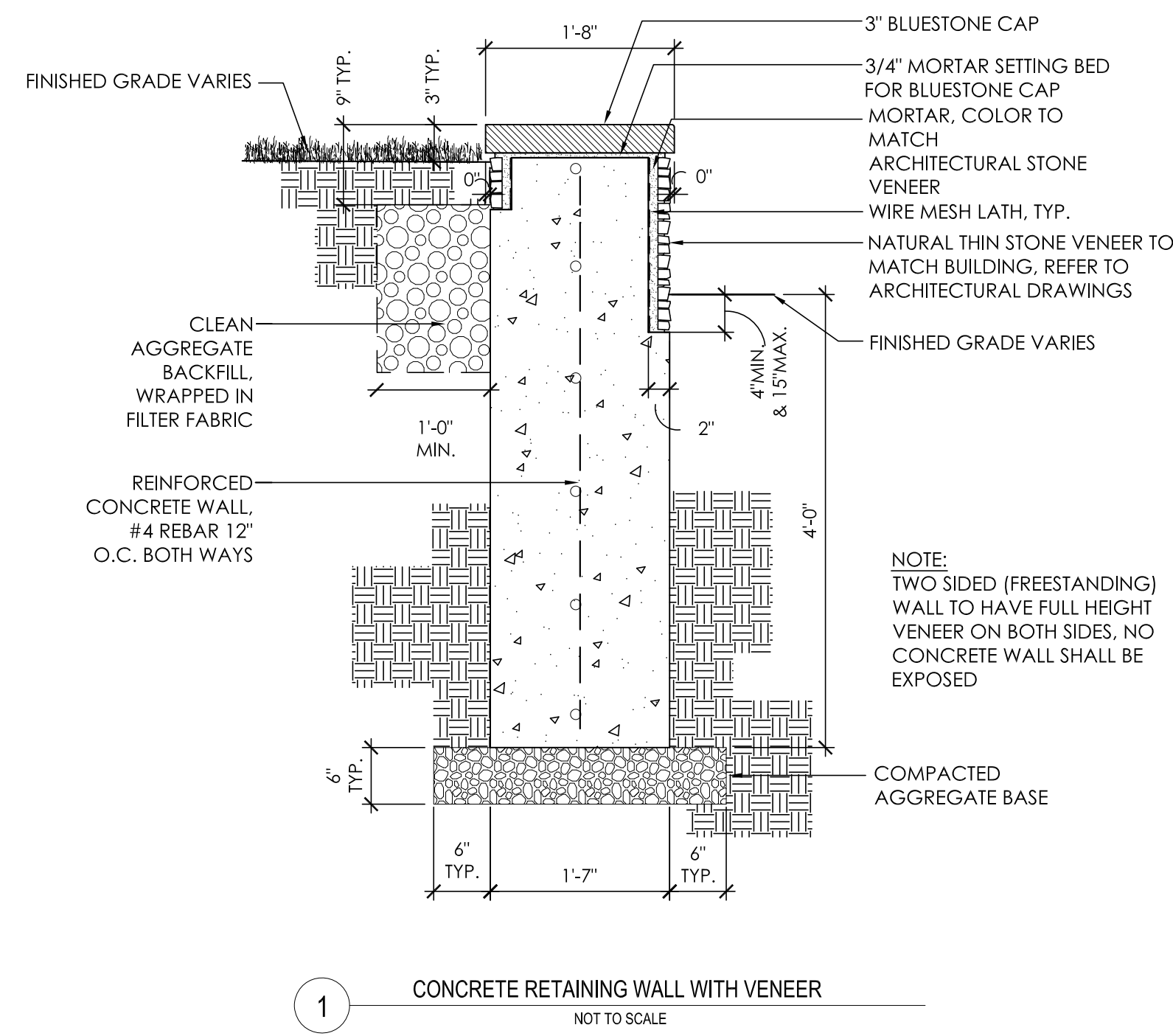

BIT. CONCRETE WALK	A	B	C
	6"	1 1/2"	1"
BIT. CONCRETE ROAD	12"	2"	1"

PVI SITE DESIGN
PVI Site Design, LLC
Civil Engineering - Land Enhancements
Master Planning - Project Management
351-206-1030

HOTEL REDEVELOPMENT
155 PORTER STREET, EAST BOSTON, MA
HUDSON 62 REALTY LLC
440 BEDFORD ST, LEXINGTON, MA 01824

REV. 1: 12-13-2017 BVSC COMMENTS	REV. 2: 02-08-2018 BVSC COMMENTS	REV. 3: 03-07-2018 BVSC COMMENTS	REV. 4: 04-19-2018 85% OWNER'S REVIEW	REV. 5: 07-06-2018 100% ISSUED FOR CONST.	REV. 6: 09-17-2019 BPOA COMMENTS	REV. 7: 11-26-2019 BPOA COMMENTS
----------------------------------	----------------------------------	----------------------------------	---------------------------------------	---	----------------------------------	----------------------------------



ISSUED FOR CONSTRUCTION
DECEMBER 8, 2017
DETAILS
SCALE: 1"=20'
JOB NO: 003-003
FILE: 003-002 -DETAILS.dwg
DRAWN: TJP
CHECKED: TJP
SHEET NO: C203
BWS SITE PLAN #17410

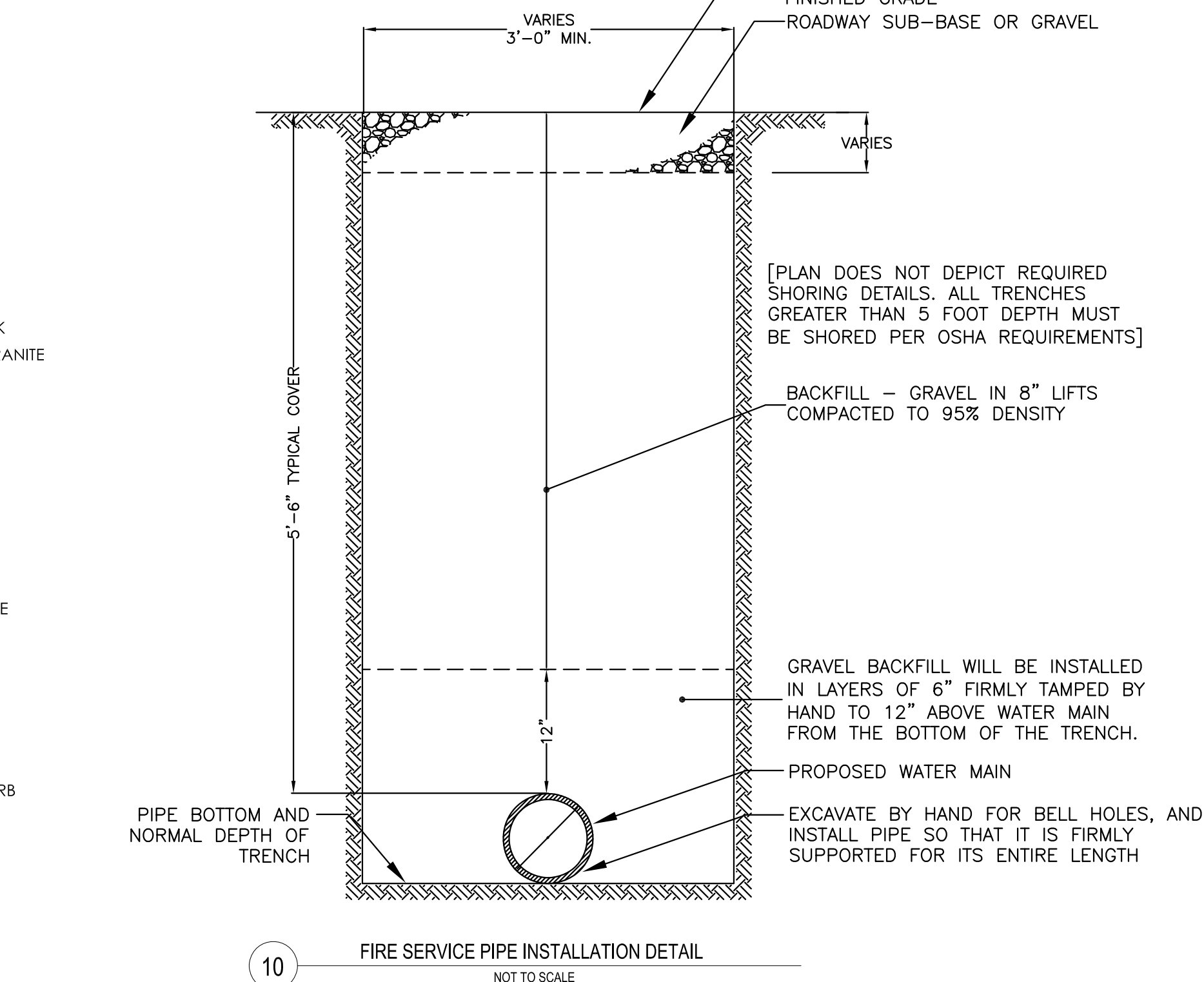
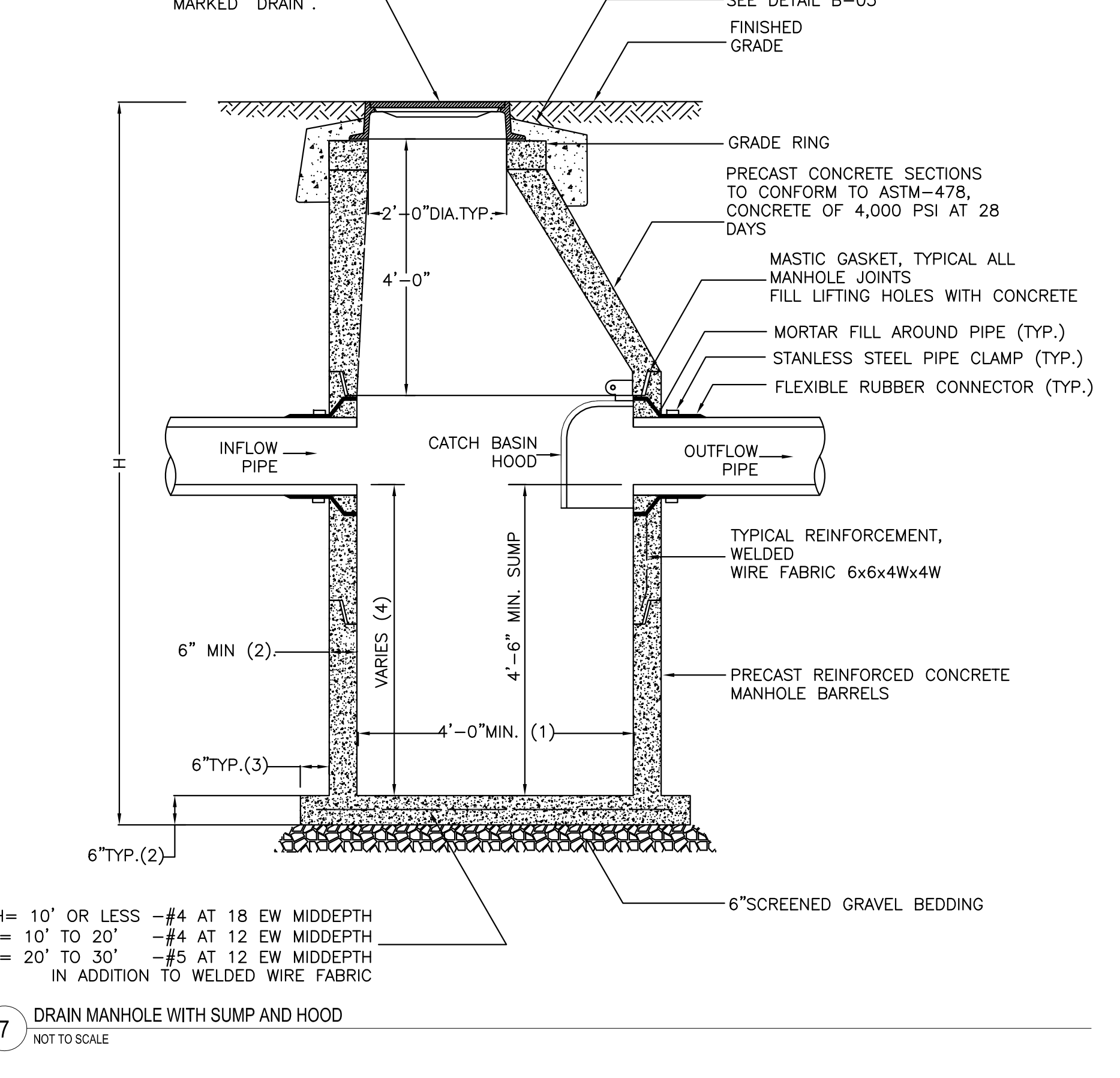
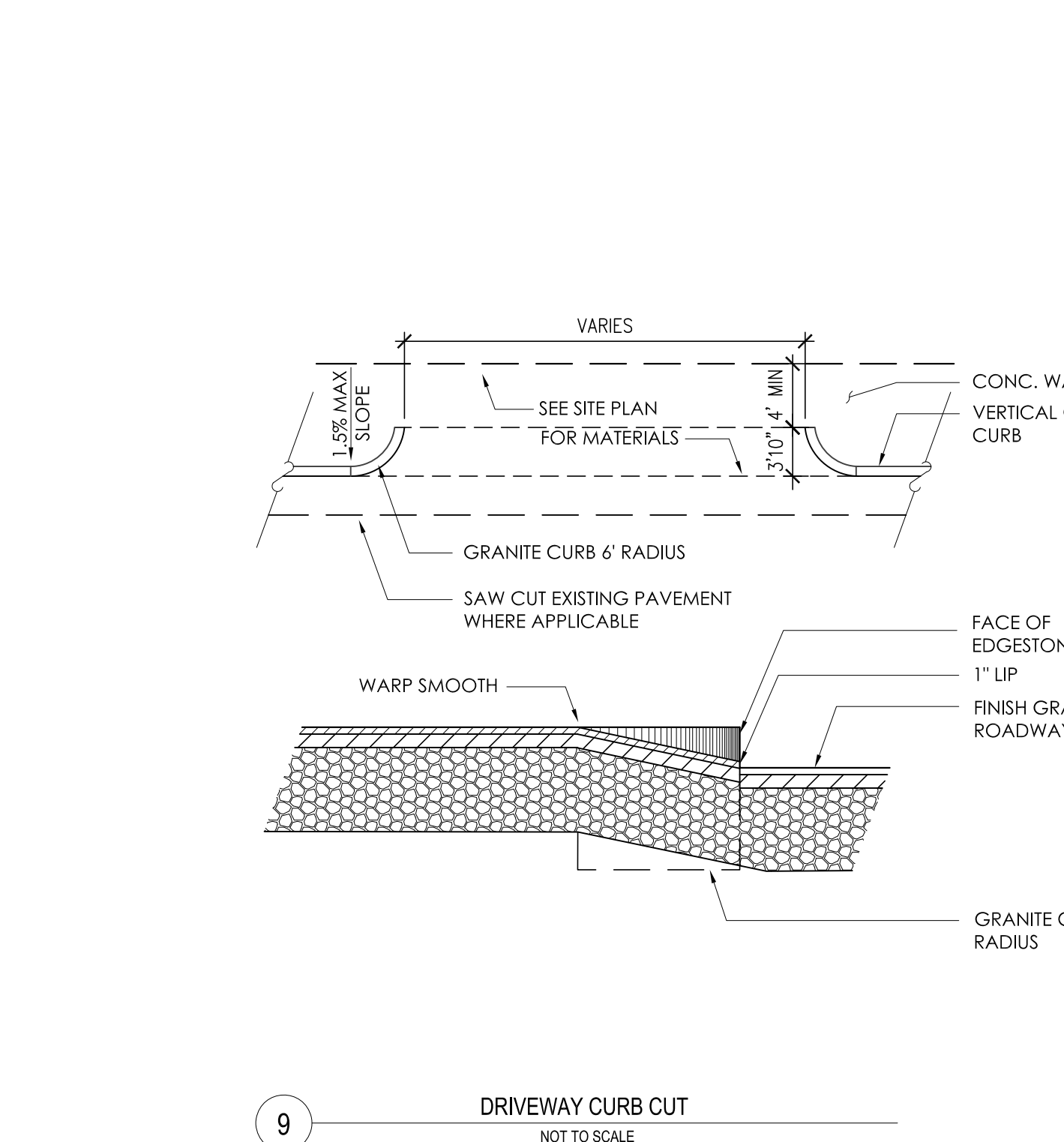
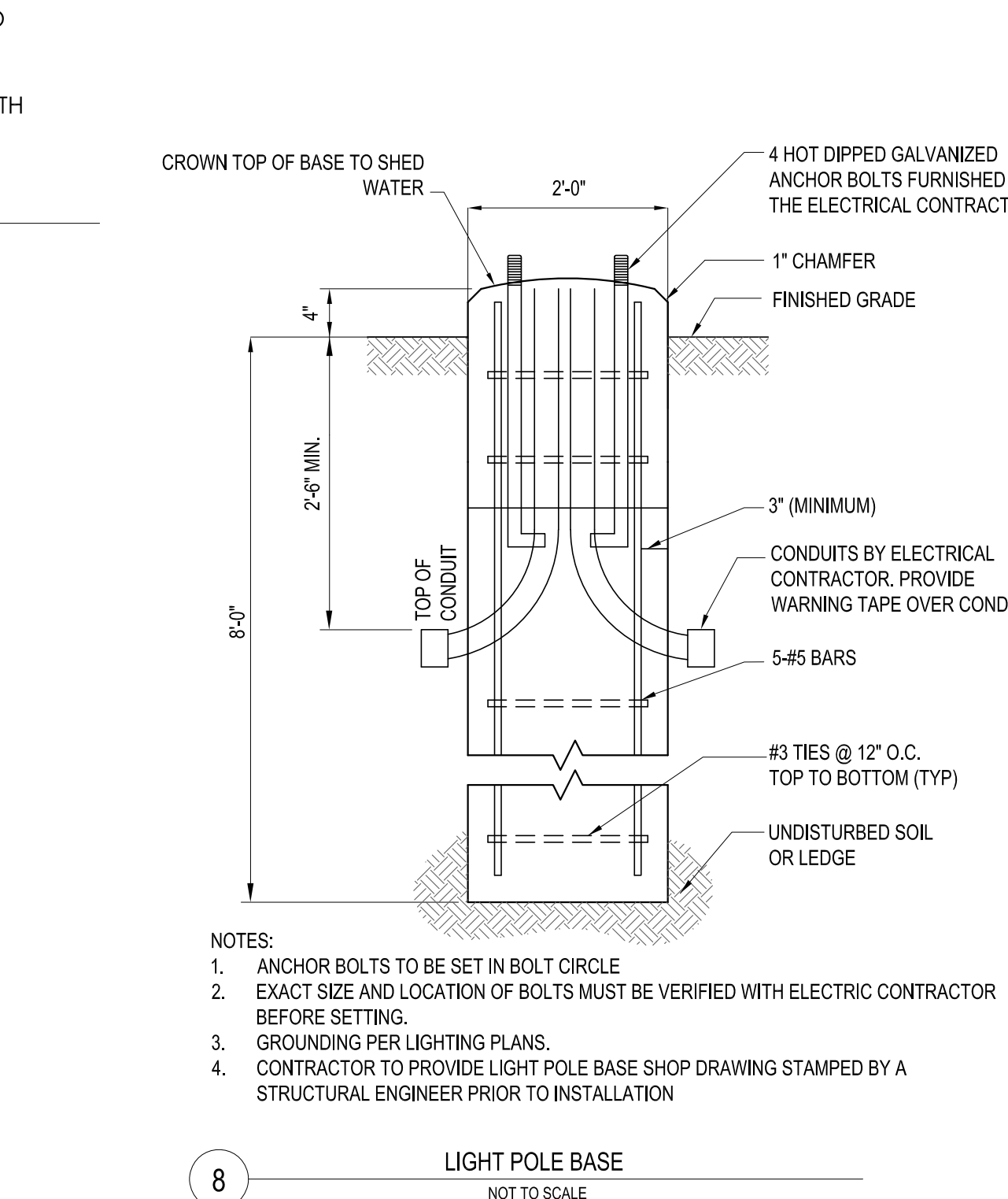
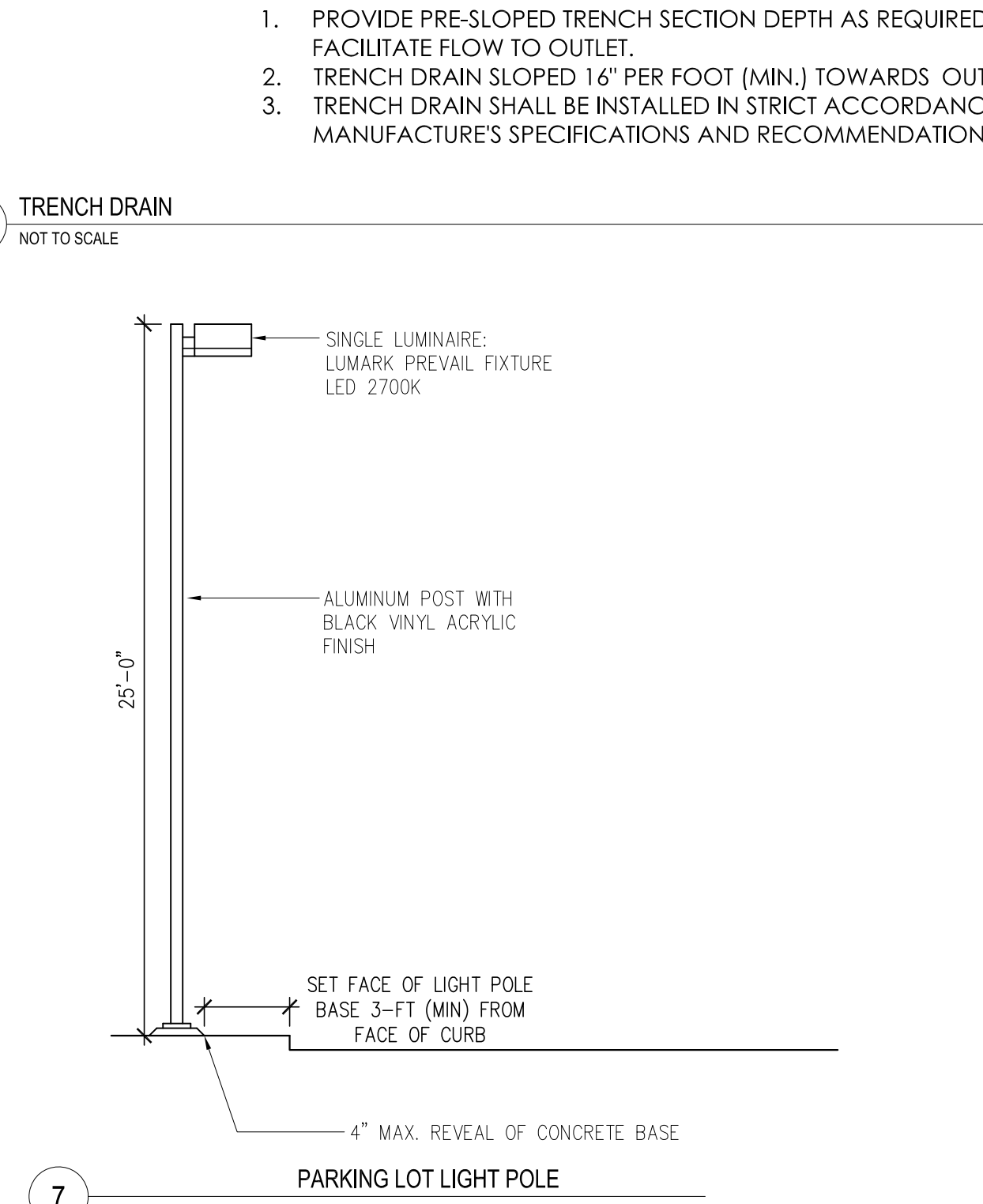
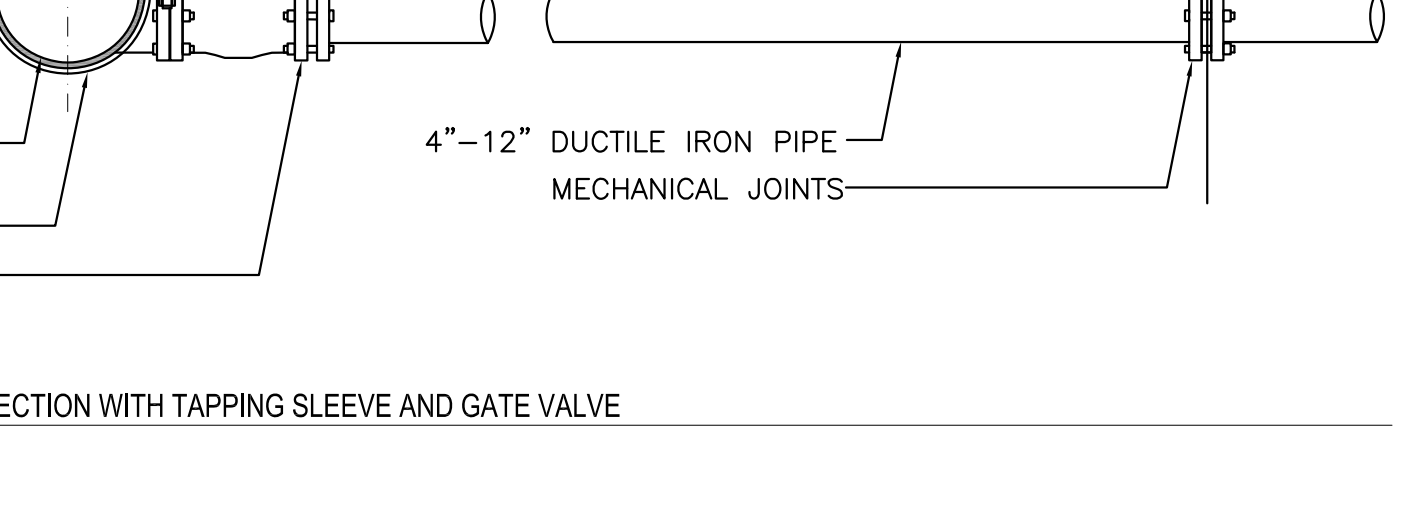
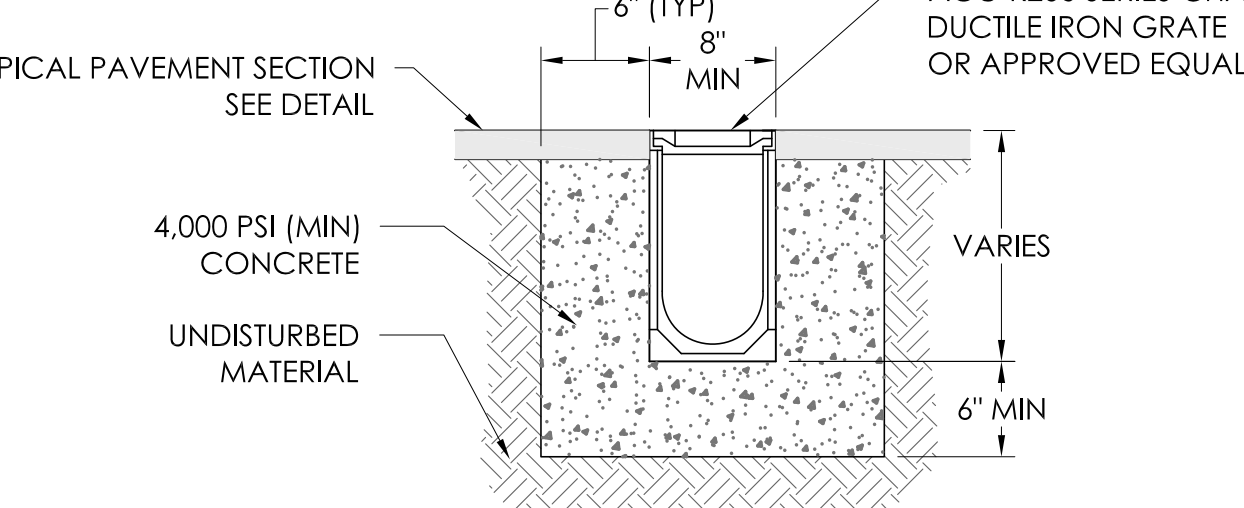
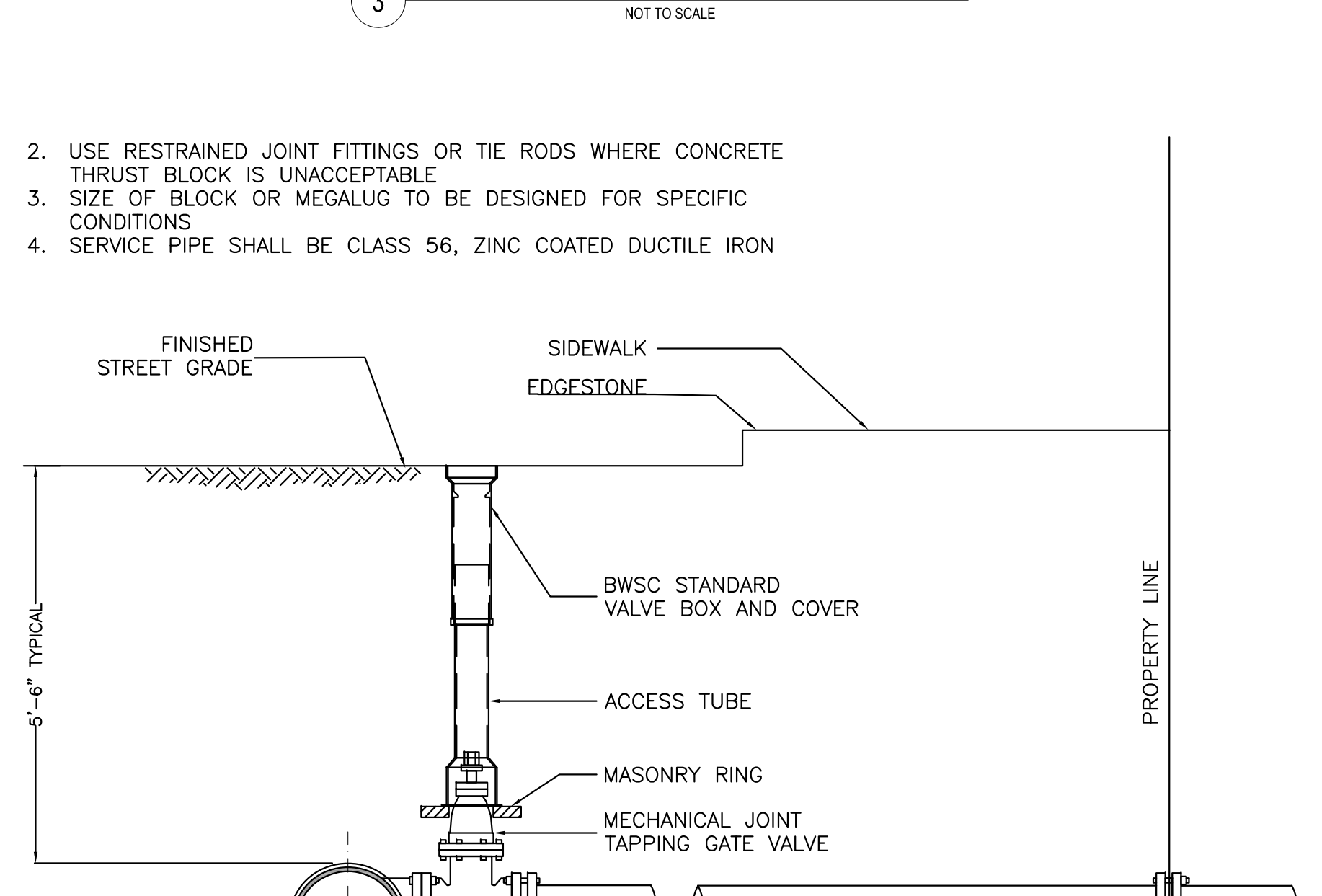
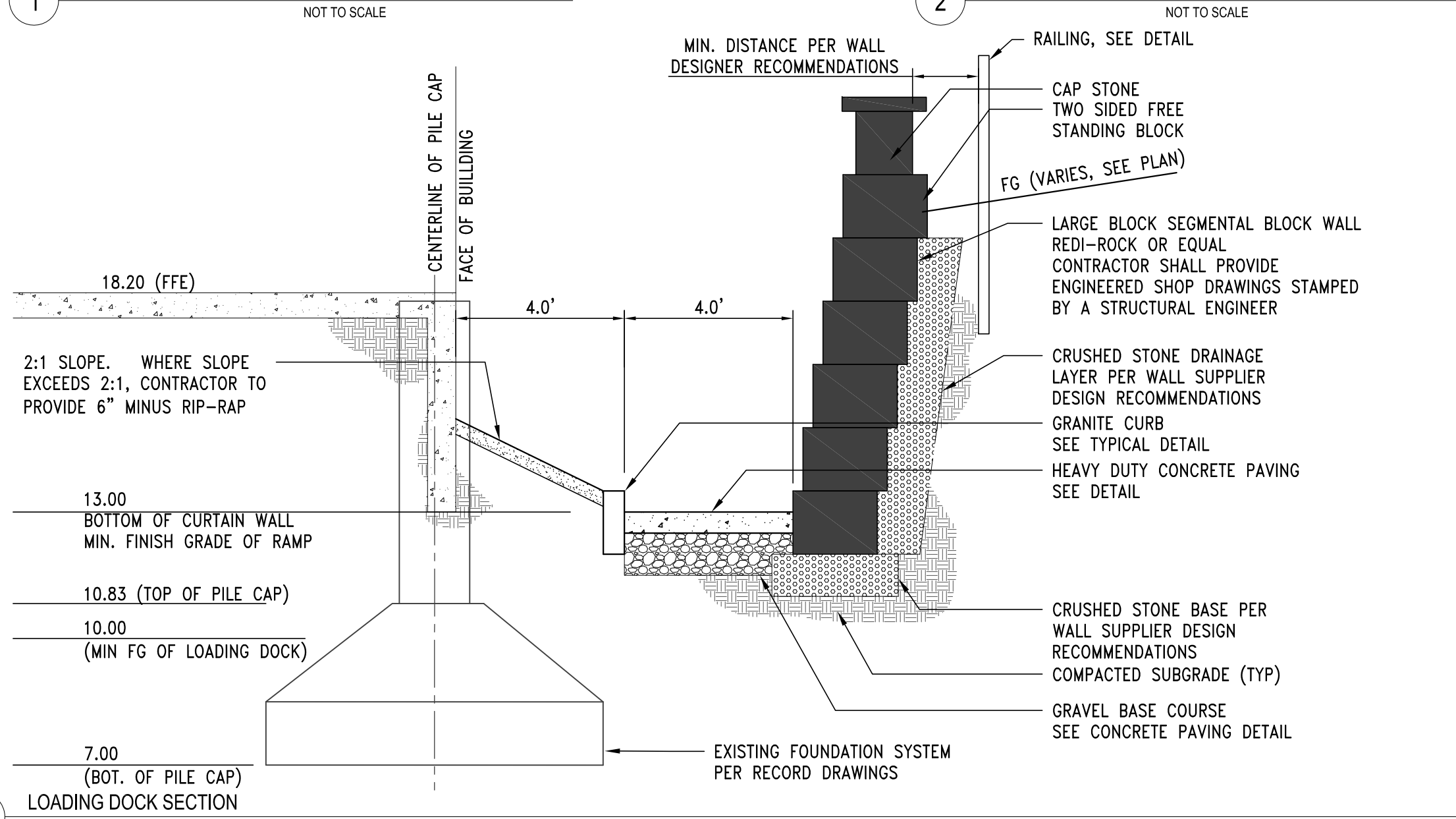
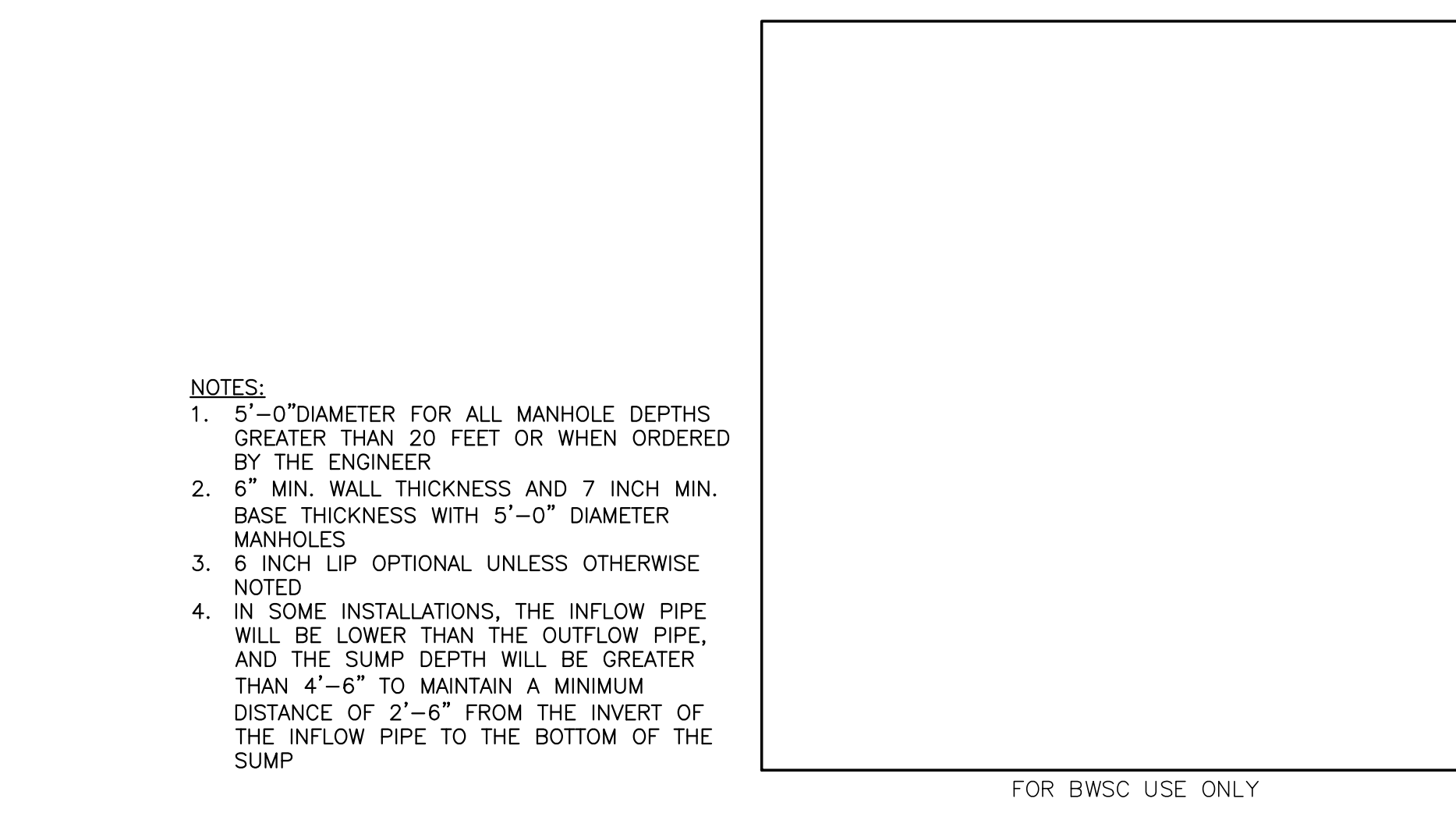
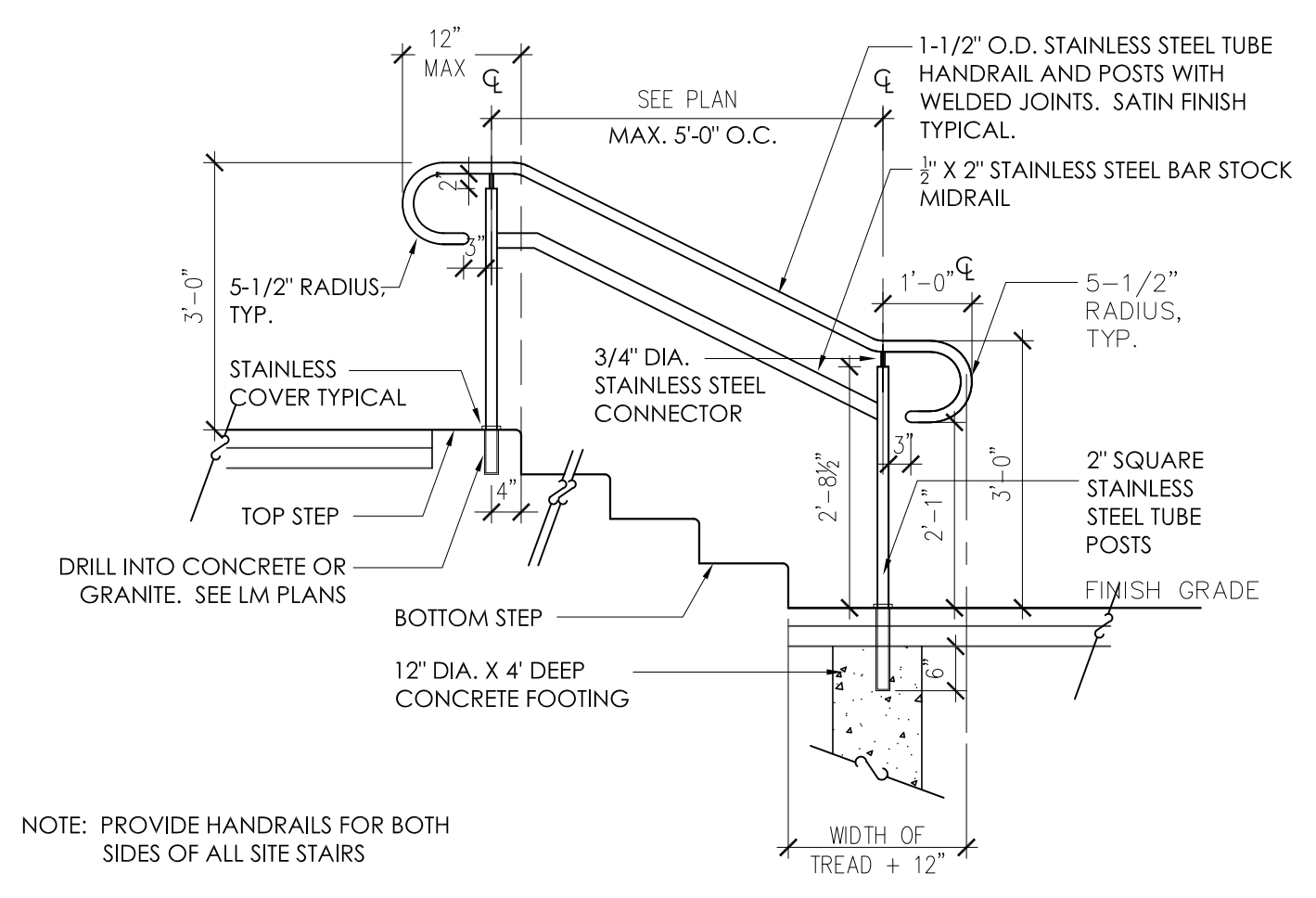
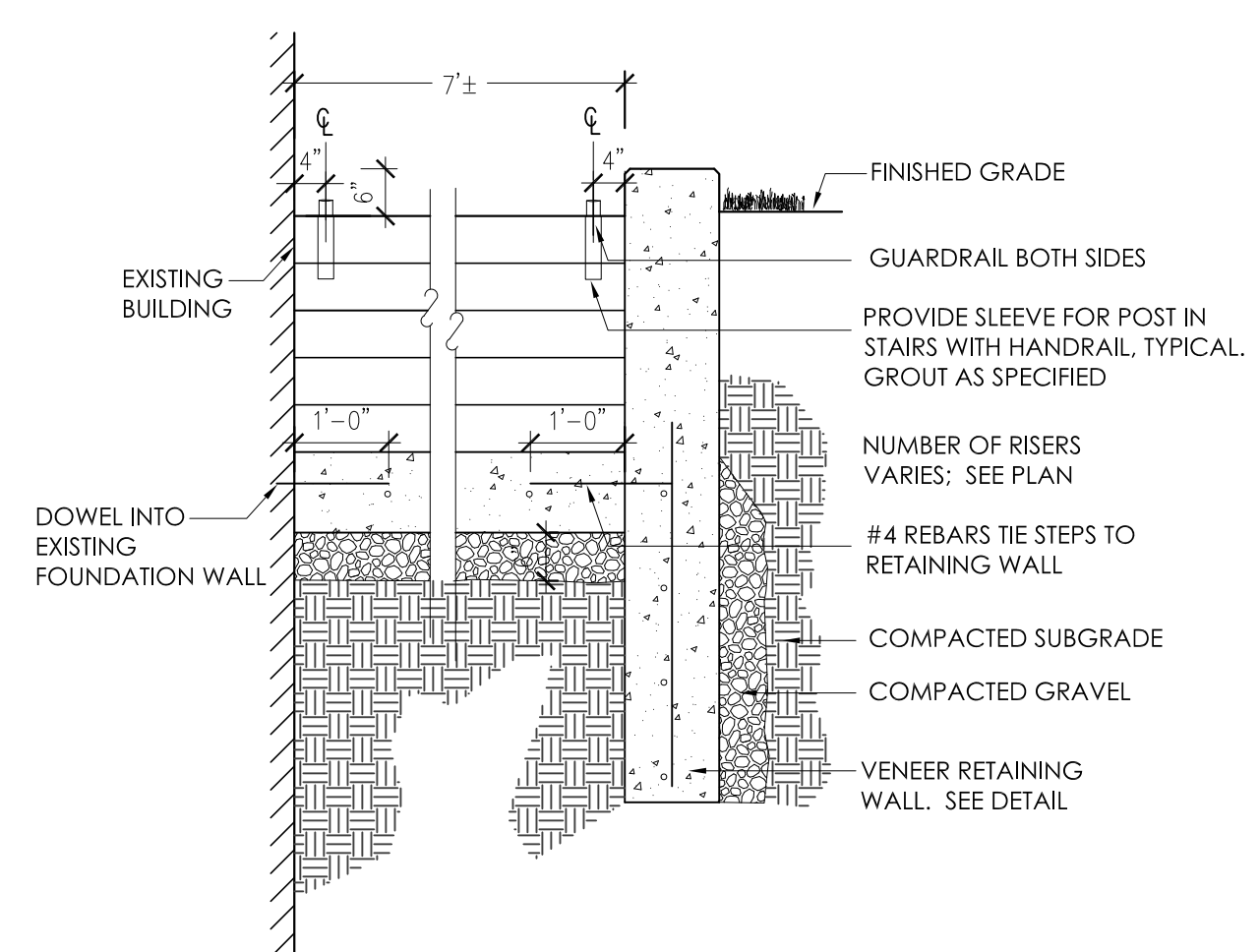
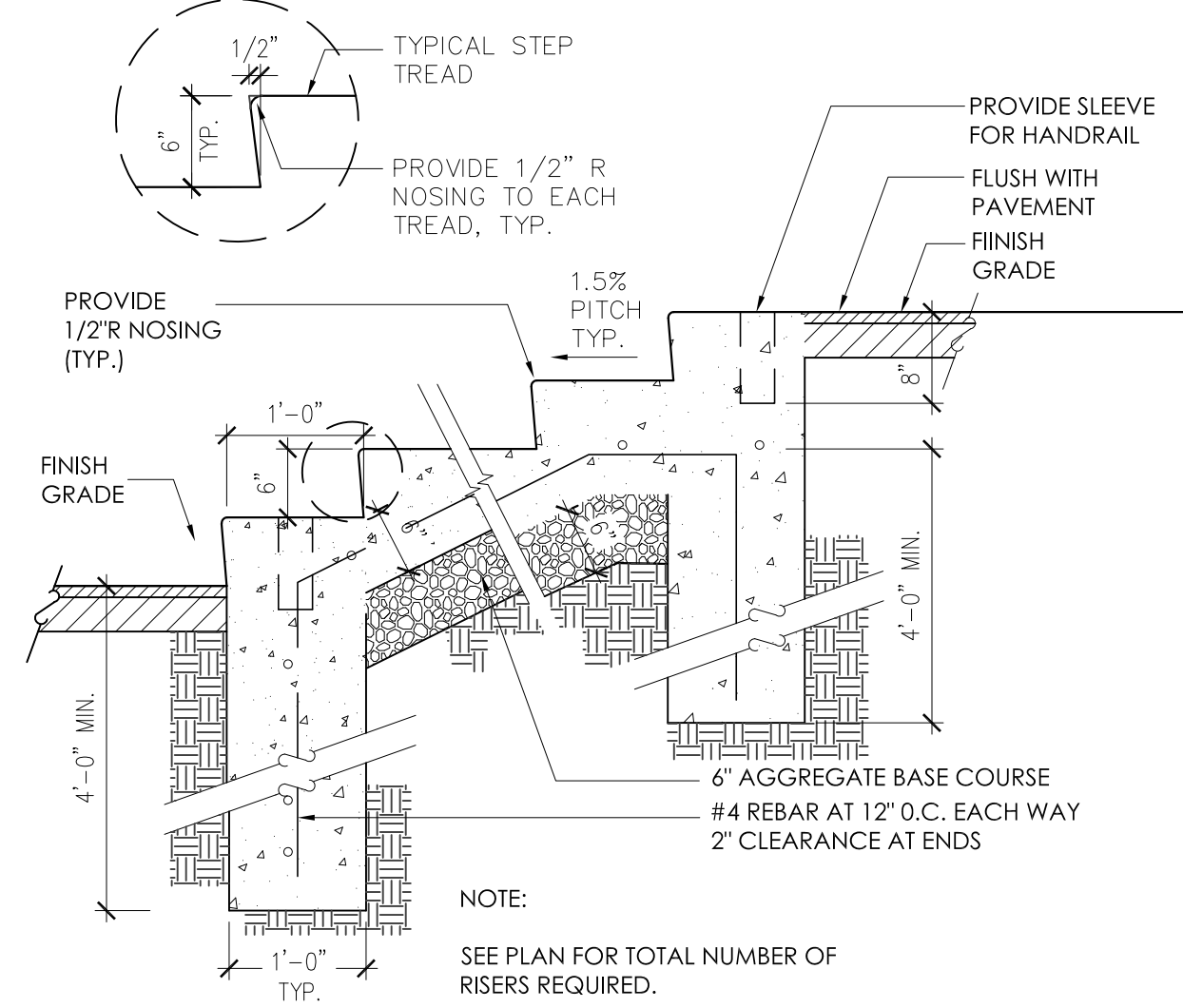

CIVIL ENGINEER: **PVI SITE DESIGN**
PVI Site Design, LLC
Civil Engineering - Land Enhancements
Master Planning - Project Management
357-206-1030

PROJECT: **HOTEL REDEVELOPMENT**
155 PORTER STREET, EAST BOSTON, MA
CLIENT/APPLICANT: **HUDSON 62 REALTY LLC**
440 BEDFORD ST, LEXINGTON, MA 01824

ISSUED FOR CONSTRUCTION
DECEMBER 8, 2017

SCALE: 1"=20'
JOB NO: 003-003
FILE: 003-003-PROF.dwg
DRAWN: TJP
CHECKED: TJP
SHEET NO: **C204**

SEAL: **TIMOTHY J. POWER**
CIVIL
No. 46908
PROFESSIONAL ENGINEER
COMMONWEALTH OF MASSACHUSETTS

BWSC SITE PLAN #17410

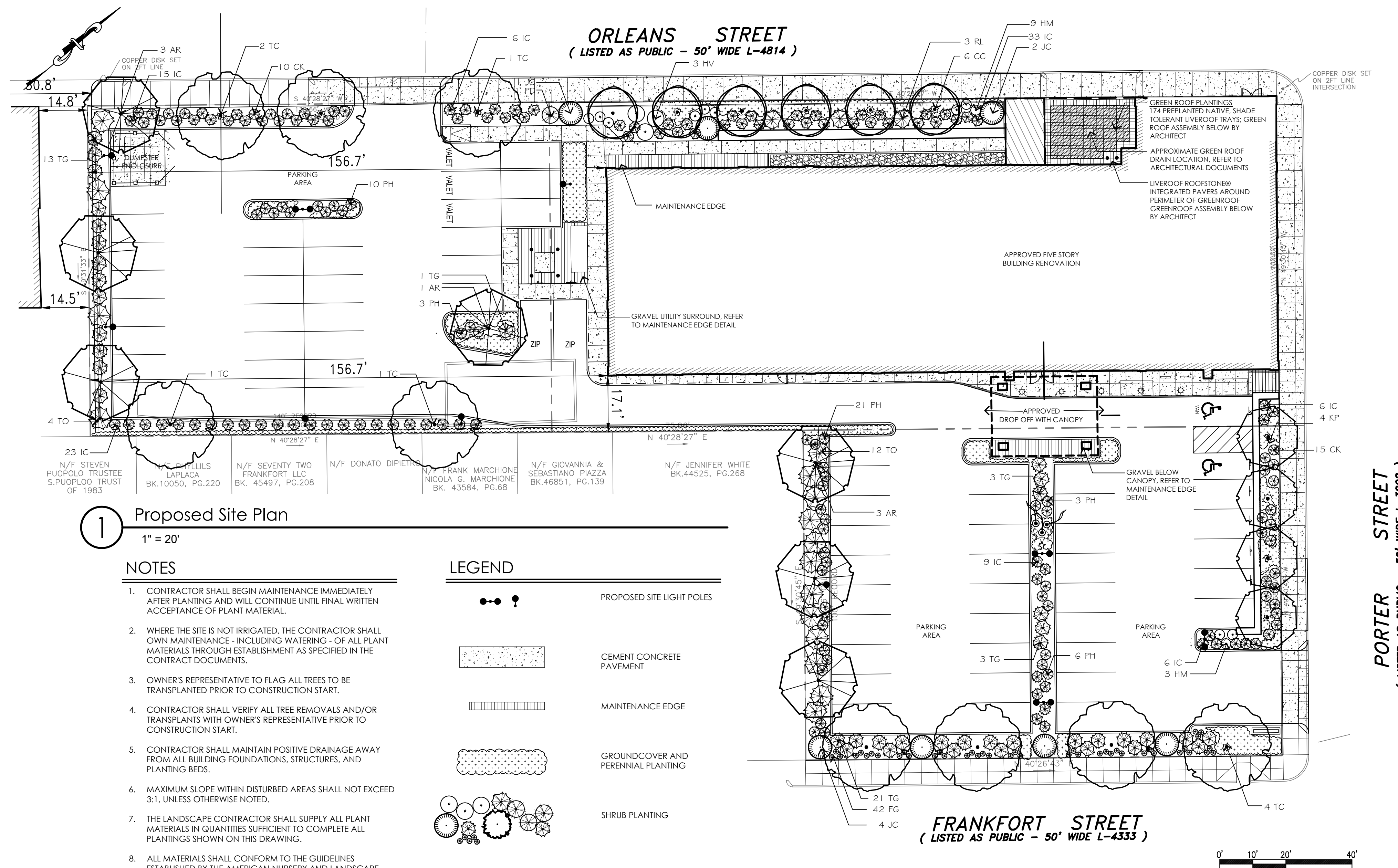

1 Proposed Site Plan
1" = 20'

NOTES

- CONTRACTOR SHALL BEGIN MAINTENANCE IMMEDIATELY AFTER PLANTING AND WILL CONTINUE UNTIL FINAL WRITTEN ACCEPTANCE OF PLANT MATERIAL.
- WHERE THE SITE IS NOT IRRIGATED, THE CONTRACTOR SHALL OWN MAINTENANCE - INCLUDING WATERING - OF ALL PLANT MATERIALS THROUGH ESTABLISHMENT AS SPECIFIED IN THE CONTRACT DOCUMENTS.
- OWNER'S REPRESENTATIVE TO FLAG ALL TREES TO BE TRANSPLANTED PRIOR TO CONSTRUCTION START.
- CONTRACTOR SHALL VERIFY ALL TREE REMOVALS AND/OR TRANSPLANTS WITH OWNER'S REPRESENTATIVE PRIOR TO CONSTRUCTION START.
- CONTRACTOR SHALL MAINTAIN POSITIVE DRAINAGE AWAY FROM ALL BUILDING FOUNDATIONS, STRUCTURES, AND PLANTING BEDS.
- MAXIMUM SLOPE WITHIN DISTURBED AREAS SHALL NOT EXCEED 3:1, UNLESS OTHERWISE NOTED.
- THE LANDSCAPE CONTRACTOR SHALL SUPPLY ALL PLANT MATERIALS IN QUANTITIES SUFFICIENT TO COMPLETE ALL PLANTINGS SHOWN ON THIS DRAWING.
- ALL MATERIALS SHALL CONFORM TO THE GUIDELINES ESTABLISHED BY THE AMERICAN NURSERY AND LANDSCAPE ASSOCIATION.
- ALL PLANTS SHALL BEAR THE SAME RELATIONSHIP TO FINISH GRADE AS TO ORIGINAL GRADES BEFORE DIGGING.
- ALL PLANTS TO BE BALLED IN BURLAP OR CONTAINERIZED.
- MULCH FOR PLANTED AREAS TO BE AGED PINE BARK; PARTIALLY DECOMPOSED, DARK BROWN IN COLOR AND FREE OF WOOD CHIPS THICKER THAN 1/4 INCH.
- SAFE USE OF MULCH IS REGULATED THROUGH S27 CMR 1.00, SECTION 10.13.10.4. THE REGULATION PROHIBITS THE NEW APPLICATION OF MULCH WITHIN 18" AROUND COMBUSTIBLE EXTERIORS OF BUILDINGS, SUCH AS WOOD OR VINYL, BUT NOT BRICK OR CONCRETE. THE MAINTENANCE EDGE SHOWN IN THE PROJECT DETAIL SHEET SHALL BE USED IN PLANT BEDS WITHIN 18" OF A COMBUSTIBLE BUILDING SURFACE.
- ALL PLANT BEDS SHALL BE EDGED IN 4-INCH COMMERCIAL GRADE BLACK STEEL LANDSCAPE EDGING.
- PLANTING SOIL MIX: LOAM THOROUGHLY INCORPORATED WITH ROTTED MANURE PROPORTIONED 5 C.Y. TO 1 C.Y. OR EQUIVALENT. FERTILIZER ADDED PER RECOMMENDED RATES OF SOILS ANALYSIS.
- THE LANDSCAPE CONTRACTOR SHALL GUARANTEE ALL PLANT MATERIALS FOR ONE (1) FULL YEAR FROM DATE OF ACCEPTANCE.
- ALL PLANT MATERIALS ARE SUBJECT TO THE APPROVAL OF THE OWNER'S REPRESENTATIVE, AT THE NURSERY, AND AT THE SITE.
- ALL AREAS OF THE SITE WHICH HAVE BEEN DISTURBED AND NOT OTHERWISE DEVELOPED SHALL BE LOAMED AND SEEDED WITH A MINIMUM DEPTH OF 6" DEPTH TOPSOIL.
- PLANT SPECIES AS INDICATED IN THE PLANT LIST ARE SUGGESTIONS ONLY. FINAL SELECTION OF SPECIES SHALL OCCUR AT THE TIME OF PLANT PURCHASE, DEPENDING ON AVAILABILITY. PLANT SIZE AND QUANTITY SHALL NOT CHANGE WITHOUT APPROVAL OF OWNER'S REPRESENTATIVE.
- PRE-PLANTED LIVE ROOF TRAYS WITH SHADE-TOLERANT, NATIVE SPECIES WILL BE A CUSTOM ORDER. CONTRACTOR SHALL ALLOW MINIMUM 12-WEEK LEAD TIME PRIOR TO SHIPMENT.
- NATIVE PLANT SELECTIONS MAY BE DIFFICULT TO SOURCE. NURSERIES SHOULD BE CONTACTED AS SOON AS POSSIBLE TO CONFIRM AVAILABILITY. POTENTIAL SOURCES INCLUDE, BUT ARE NOT LIMITED TO:
 - NASAMI FARM, WHATLEY, MA, NEWENGLANDWILD.ORG/VISIT/NASAMI-FARM
 - NATIVE, FAIRFIELD, CT, ANATIVEPLANTNURSERY.COM
 - EARTH TONES NATIVE PLANTS, WOODBURY, CT, EARTHTONENATIVES.COM

LEGEND

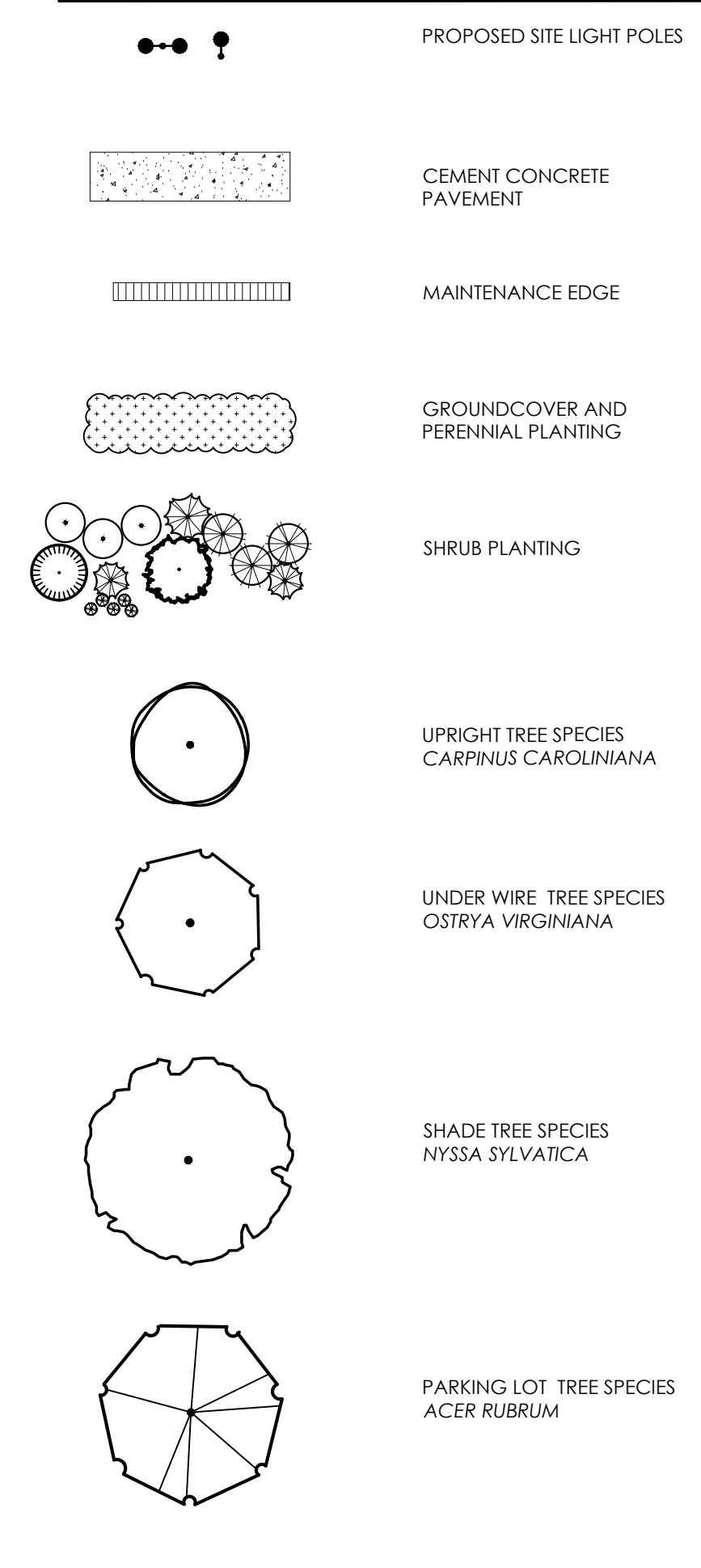

GREEN ROOF PLANTINGS

- GREEN ROOF SHALL BE PRE-PLANTED LIVEROOF STANDARD MODULES AS MANUFACTURED BY LIVEROOF, LLC, 14109 CLEVELAND ST, NUNICA MI 49448 USA, 1-616-842-1392, SALES@LIVEROOF.COM, HTTPS://LIVEROOF.COM
- PLANT SPECIES SHALL BE SELECTED FOR LOCAL ZONE, DROUGHT TOLERANCE, AND SHADE TOLERANCE. INVASIVE PLANT SPECIES SHALL NOT BE USED.
 - MODULE INFORMATION:
 - SOIL DEPTH: APPROXIMATELY 4 1/2"
 - MODULE SIZE (PLASTIC): 1' X 2' X 3-1/2"
 - SATURATED WEIGHT: APPROXIMATELY 29 LBS PER SQUARE FOOT
 - DRY WEIGHT: APPROXIMATELY 20 POUNDS PER SQUARE FOOT
 - *SOIL DRY WEIGHTS MAY VARY REGIONALLY DEPENDING UPON THE LOCALLY SOURCED AGGREGATES. CONFIRM DRY WEIGHTS WITH LOCAL LIVEROOF LICENSED GROWER.
- ROOF ASSEMBLY BELOW MODULES (WATERPROOFING, INSULATION, ETC) SHALL BE SELECTED IN COORDINATION WITH THE PROJECT ARCHITECT

SUGGESTED PLANT SCHEDULE

SYMBOL	BOTANICAL NAME	COMMON NAME	QTY	SIZE	COMMENT
DECIDUOUS TREES					
AR	ACER RUBRUM	RED MAPLE	7	2 - 2 1/2" CAL.	
KP	OSTRYA VIRGINIANA*	AMERICAN HOPHORNBEAM	4	2 - 2 1/2" CAL.	
TC	NYSSA SYLVATICA*	SOUR GUM	9	2 - 2 1/2" CAL.	
CC	CARPINUS CAROLINIANA*	AMERICAN HORNBEAM	6	2 - 2 1/2" CAL.	
SHRUBS					
HV	HAMAMELIS VIRGINIANA	WITCHHAZEL	3	4-5' HT., HEAVY	
HM	HYDRANGEA ARBORESCENS*	WILD HYDRANGEA	12	3 GALLON	
IC	ILEX GLABRA	INKBERRY	98	3 GALLON	
JC	JUNIPERUS VIRGINIANA*	JUNIPER	7	5-6' B4B	
RL	LEUCOTHOE AXILLARIS	COASTAL DOGHOBBLE	3	5 GALLON	
TG	TAXUS CANADENSIS	YEW	41	18-24" B4B	
TO	THUJA OCCIDENTALIS*	ARBORVITAE	16	6-7' B4B	
ORNAMENTAL GRASSES					
CK	RUDBECKIA FULGIDA*	BLACK-EYED SUSAN	25	1 GALLON	
FG	SISYRINCHIUM ANGUSTIFOLIUM*	NARROW BLUE-EYED GRASS	42	2 GALLON	
PD	SORGHASTRUM NUTANS*	INDIANGRASS	1	1 GALLON	
PH	MUHLENBERGIA CAPILLARIS*	PINK MUHLY GRASS	43	2 GALLON	
PERENNIALS AND GROUNDCOVER					
	ARCTOSTAPHYLOS UVA-URSI*	BEARBERRY	100	1 GALLON	
	ACHILLEA SP.*	YARROW	100	1 GALLON	
	ASARUM CANADENSE	WILD GINGER	100	1 GALLON	
	EURYBIA DIVARICATUS*	WHITE WOOD ASTER	100	1 GALLON	
	GALLIARDIA ARISTATA	BLANKET FLOWER	100	1 GALLON	
	JEFFERSONIA DIPHYLLA*	TWINLEAF	100	1 GALLON	
	JUNIPERUS HORIZONTALIS*	CREeping JUNIPER	100	1 GALLON	
	MAIANTHEMUM CANADENSE*	CANADA MAYFLOWER	100	1 GALLON	
	MONARDA FISTULOSA*	WILD BERGAMOT	100	1 GALLON	
	PHILOX SUBULATA*	MOSS PHLOX	100	1 GALLON	
	RUDBECKIA LACINIATA*	CUTLEAF CONEFLOWER	100	1 GALLON	
	VERBENA HASTATA	BLUE VERVAIN	100	1 GALLON	
	YUCCA FILAMENTOSA*	ADAM'S NEEDLE	100	1 GALLON	

* INDICATES DROUGHT TOLERANT SPECIES PER LOCAL NURSERY CATALOGS, EXTENSION SVCS.

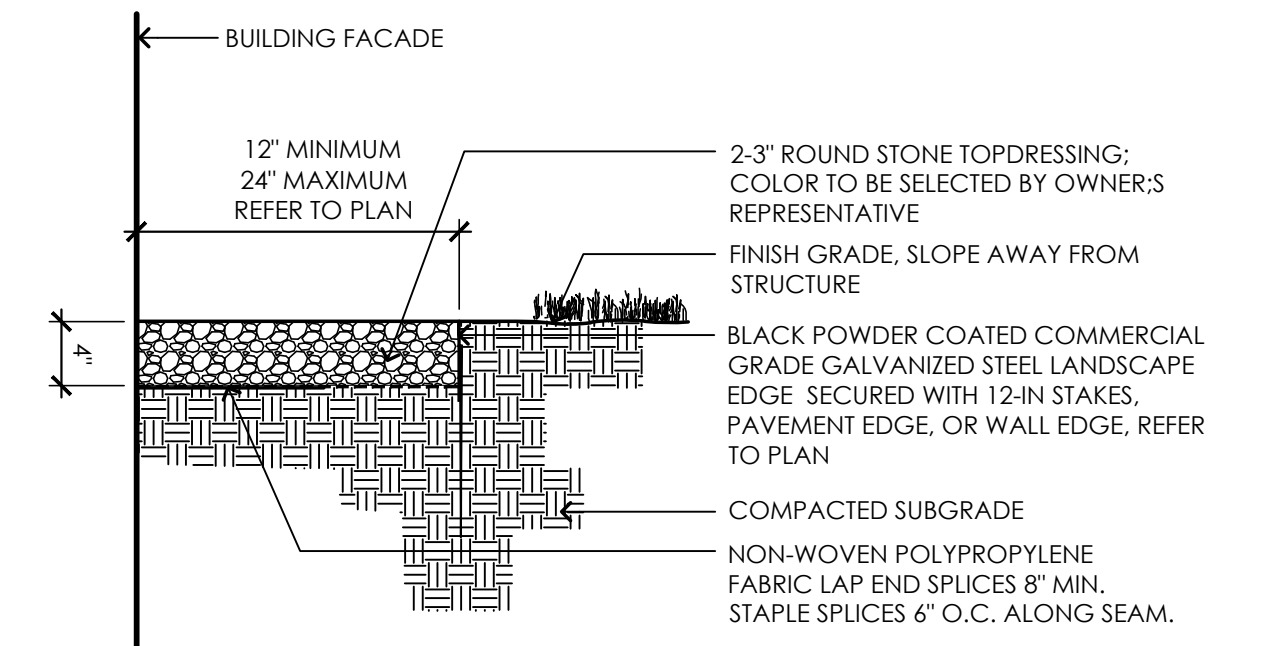

2 MAINTENANCE EDGE
NTS

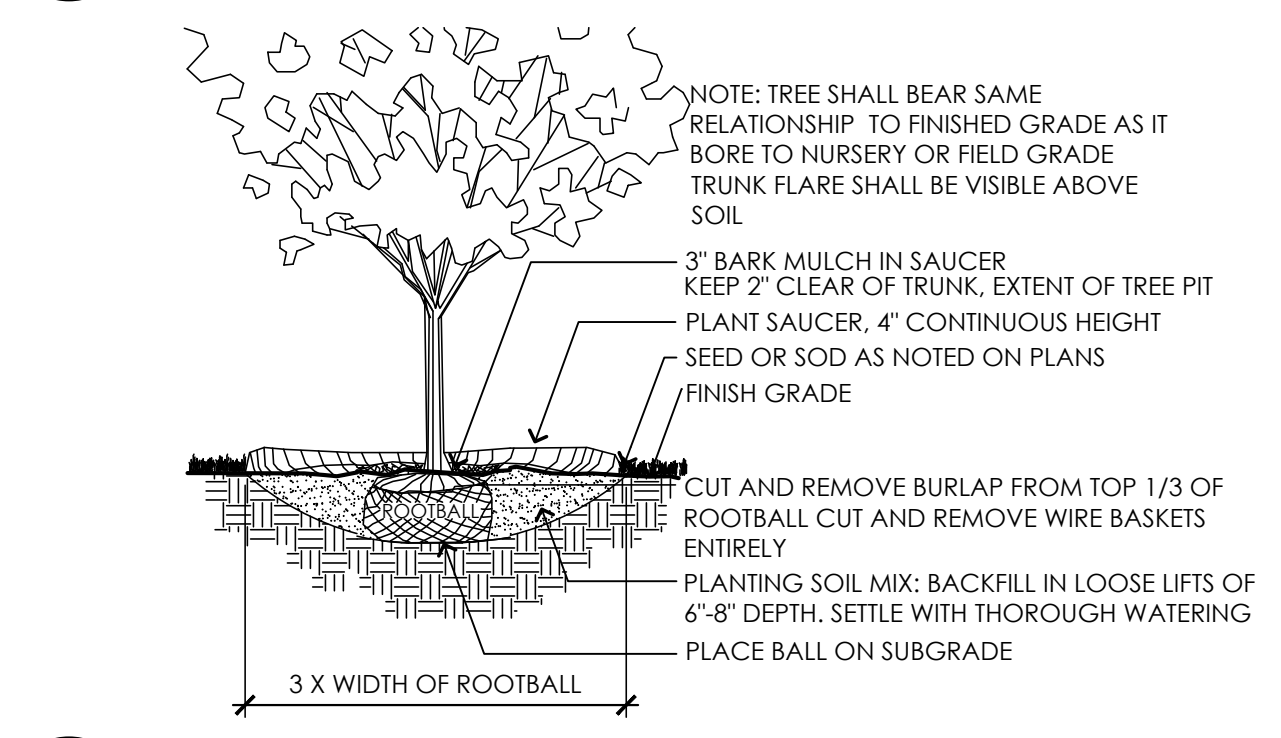

3 TYPICAL DECIDUOUS TREE PLANTING
NTS

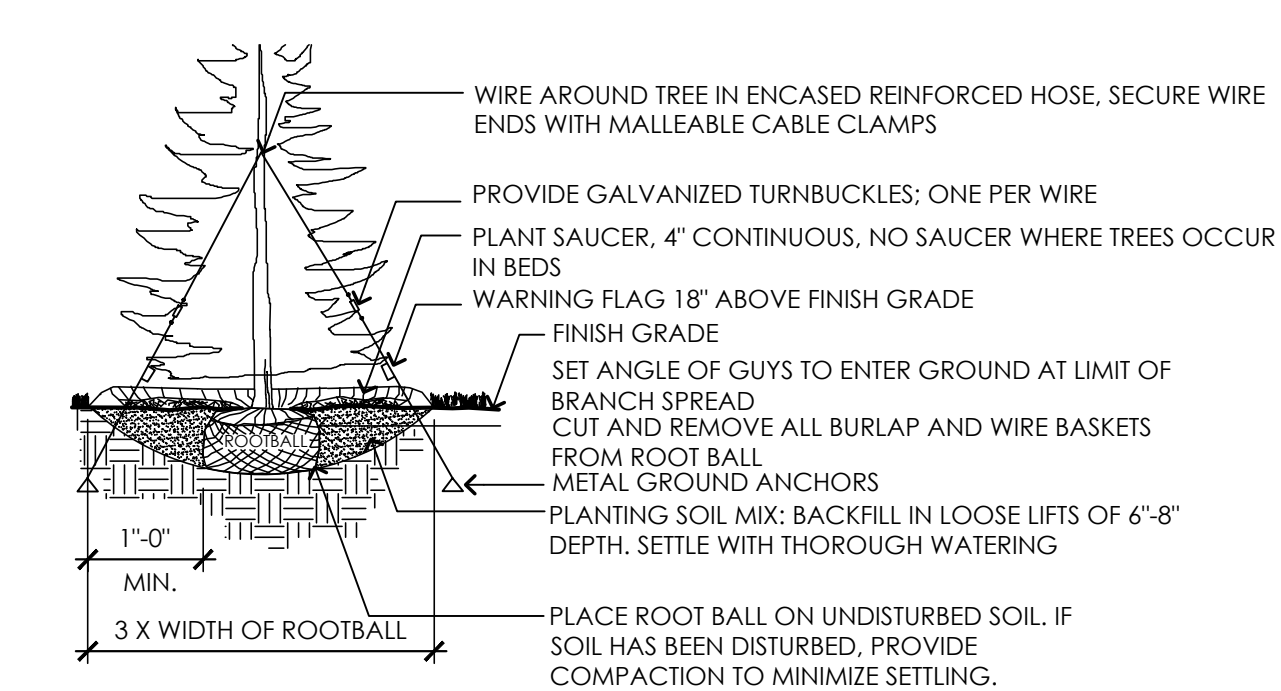

4 TYPICAL EVERGREEN TREE PLANTING
NTS

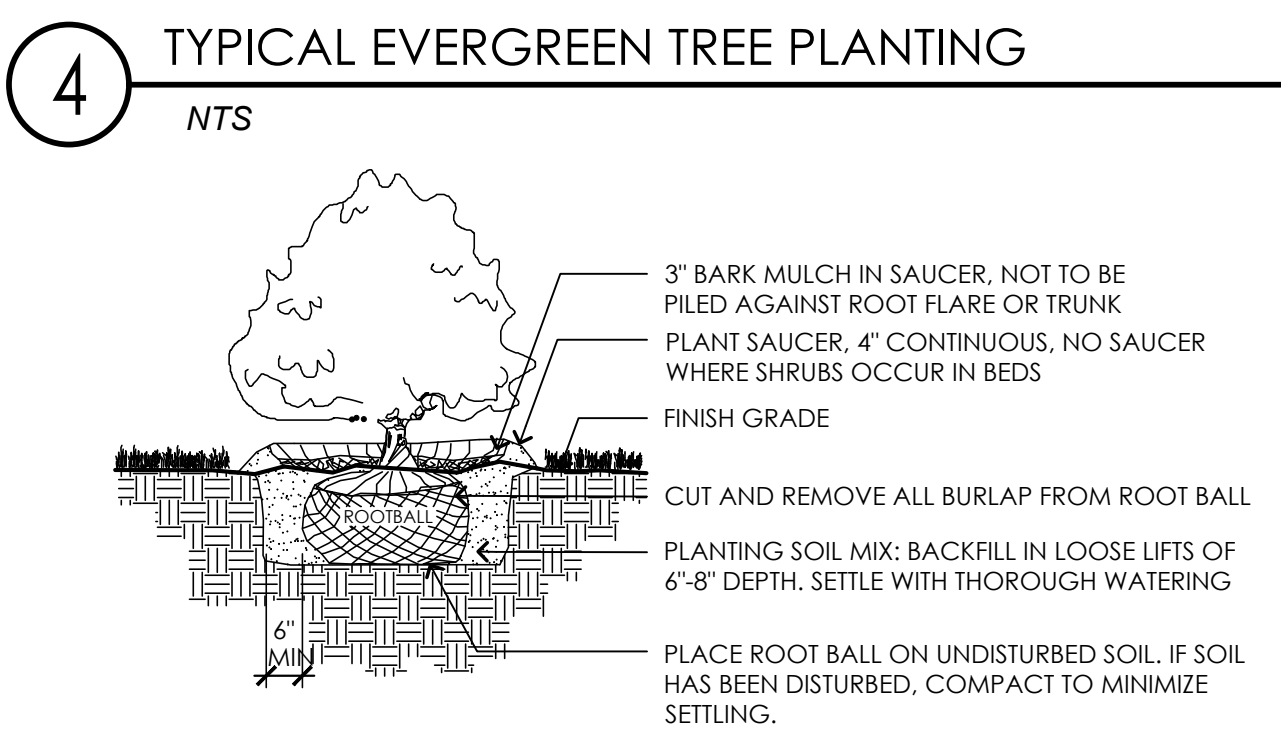

5 TYPICAL SHRUB PLANTING
NTS

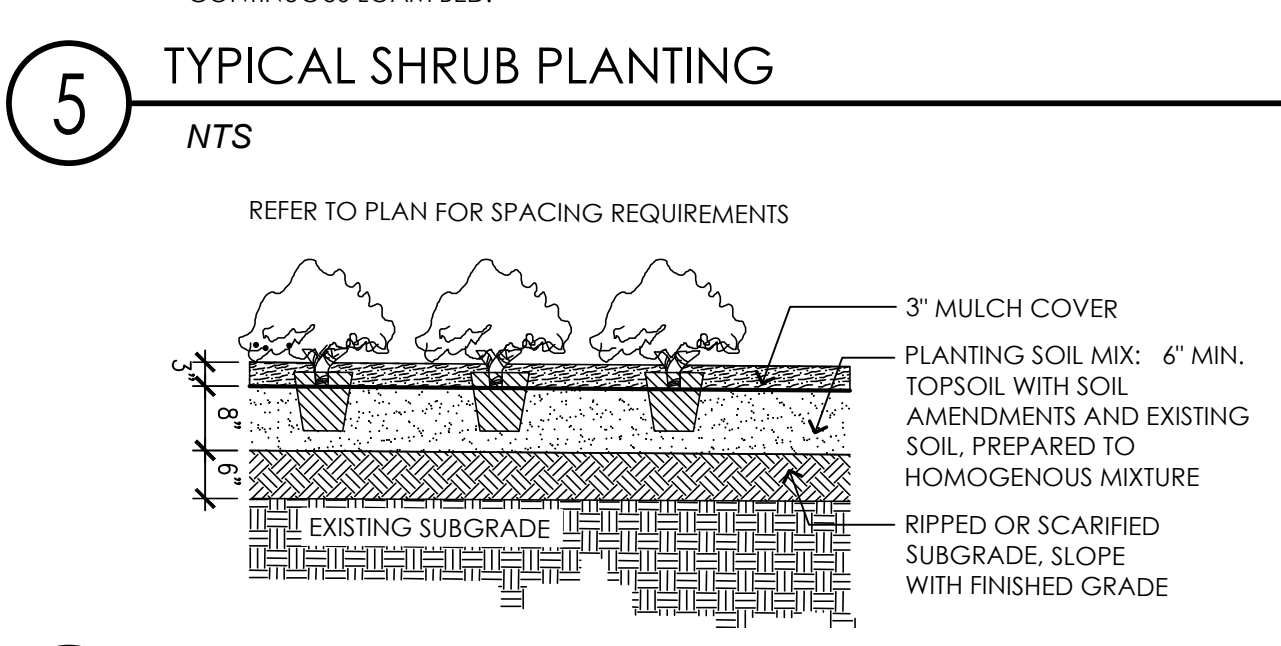

6 TYPICAL GROUNDCOVER PLANTING
NTS

NOTES

1. ROOF LEVEL PLANTINGS SHALL BE INSTALLED IN PRE-PLANTED STANDARD MODULES FROM LIVEROOF. [HTTPS://LIVEROOF.COM/](https://liveroof.com/), 1-800-875-1392, LOCAL REPRESENTATIVE BEN LUCAS, 860-710-8512, LIVEROOF@PRIDESCORNER.COM
2. PRE-PLANTED LIVE ROOF TRAYS WITH SHADE-TOLERANT, NATIVE SPECIES WILL BE A CUSTOM ORDER. CONTRACTOR SHALL ALLOW MINIMUM 12-WEEK LEAD TIME PRIOR TO SHIPMENT.
3. MANUFACTURER'S ILLUSTRATIONS ARE PROVIDED TO CONCEPTUALLY ASSIST PROFESSIONALS IN PRICING AND PLANNING LIVEROOF INSTALLATIONS. RBLA DESIGN DOES NOT ACCEPT RESPONSIBILITY FOR ENGINEERING, WATERPROOFING, AND/OR ARCHITECTURAL ATTACHMENTS OR INTERFACES BASED ON ILLUSTRATIONS. A QUALIFIED ROOFING SPECIALIST SHALL BE CONSULTED TO DETERMINE APPROPRIATE WATERPROOFING, ROOF DECK MATERIALS, STRUCTURAL LOADS, AND SUITABLE DESIGN.
4. PER CITY OF BOSTON CONSERVATION COMMISSION REQUIREMENTS, PLANTS SELECTED FOR TRAYS SHALL BE STRAIGHT NATIVE SPECIES, VARIETIES AND CULTIVARS (NATIVARS) SHALL NOT BE ACCEPTED. CONTRACTOR SHALL PROVIDE PLANT LIST FROM MANUFACTURER PRIOR TO INSTALLATION.

1 LiveRoof STANDARD SYSTEM

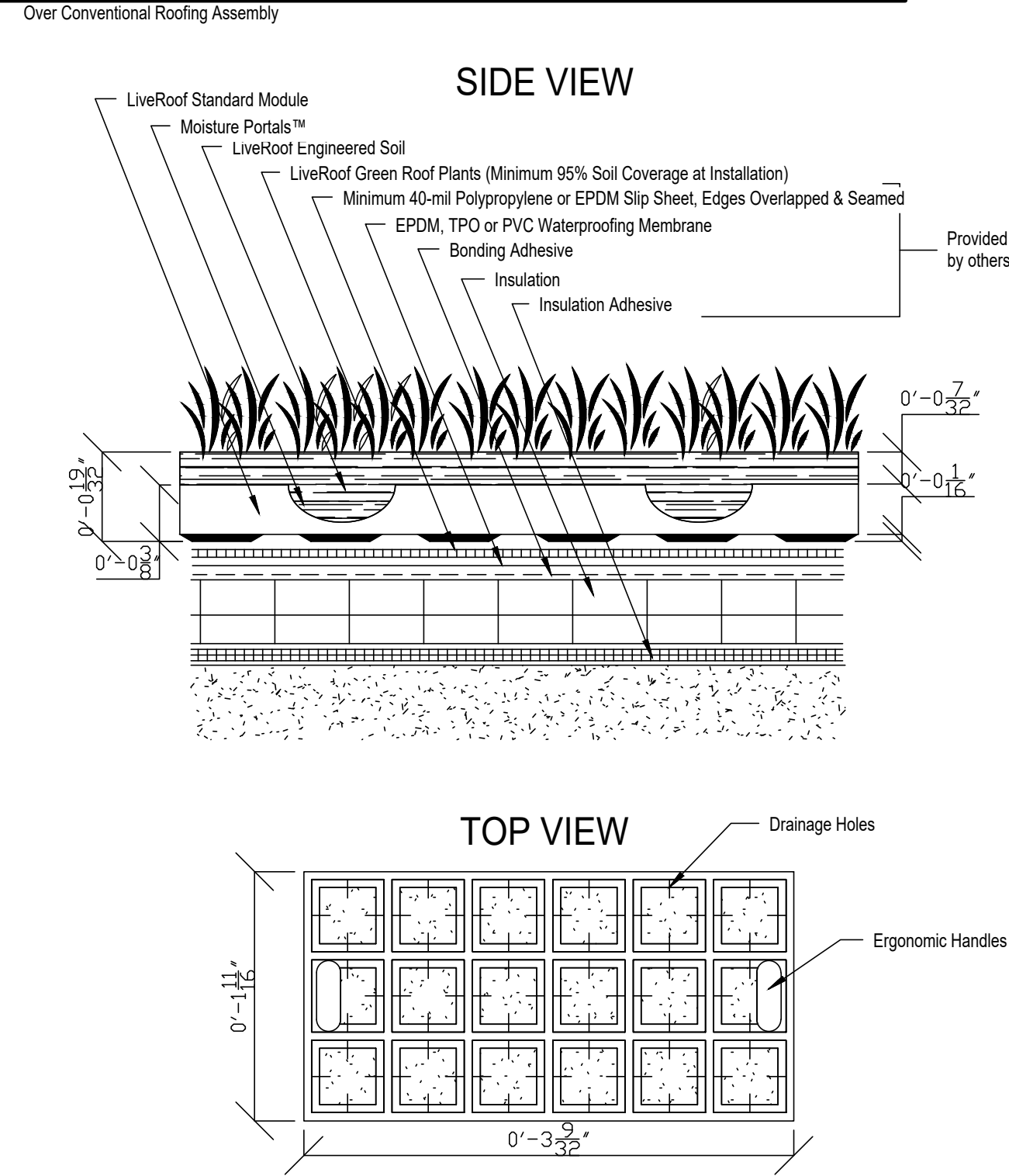

2 RoofEdge Standard Aluminum Edge Restraint

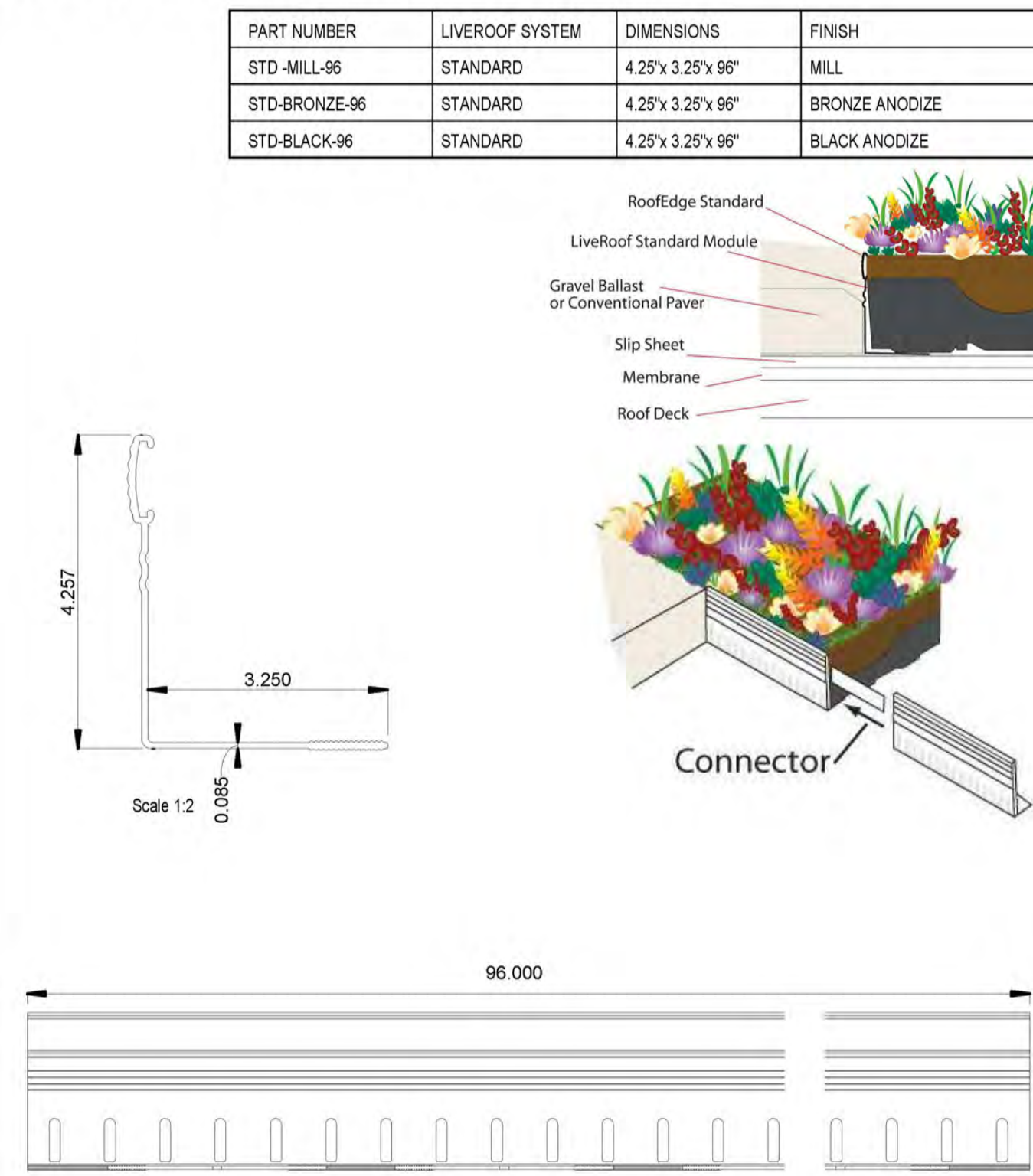

3 Drain Application

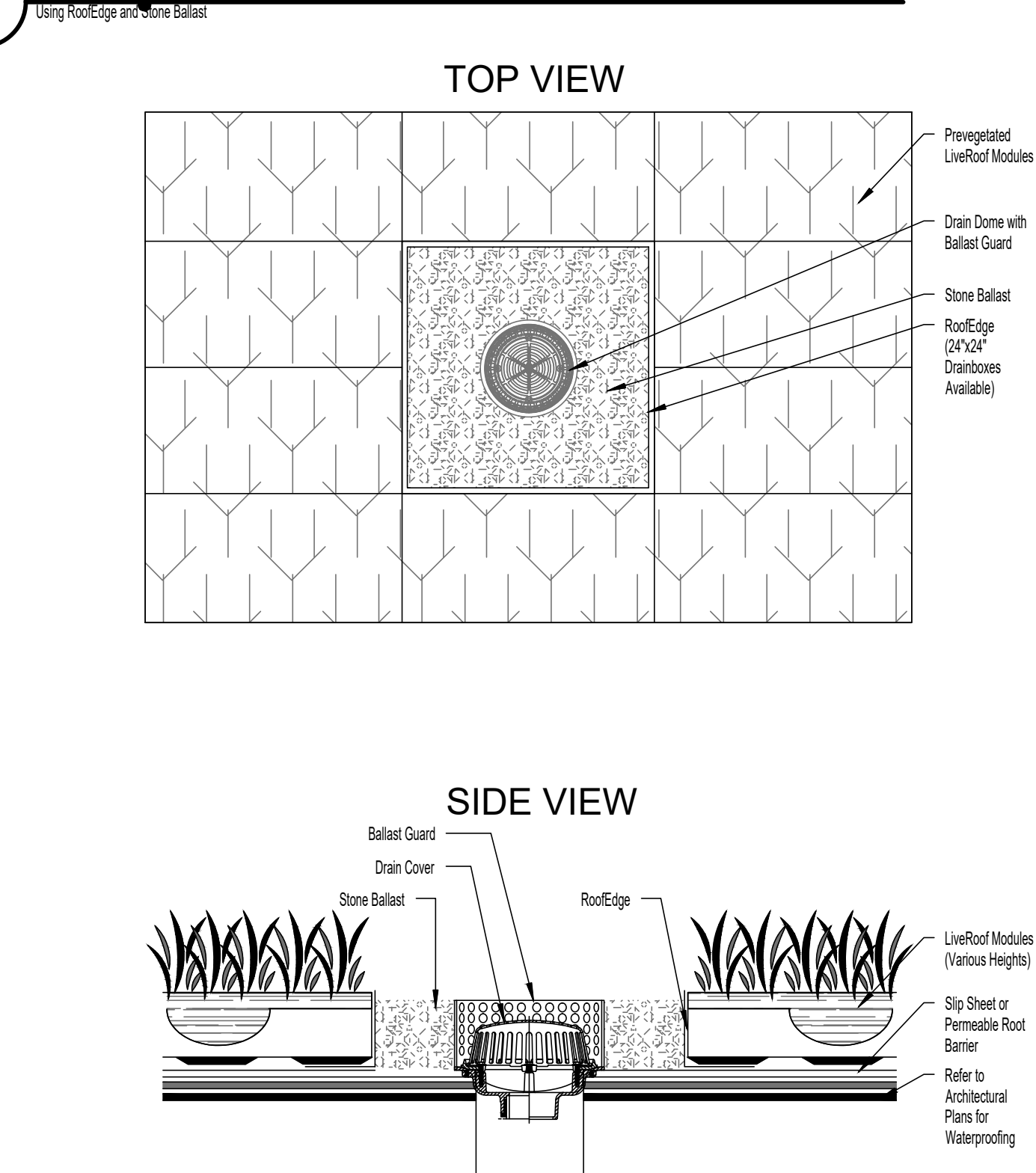

4 PipeRunner

irrigation solution for use with LiveRoof Modules

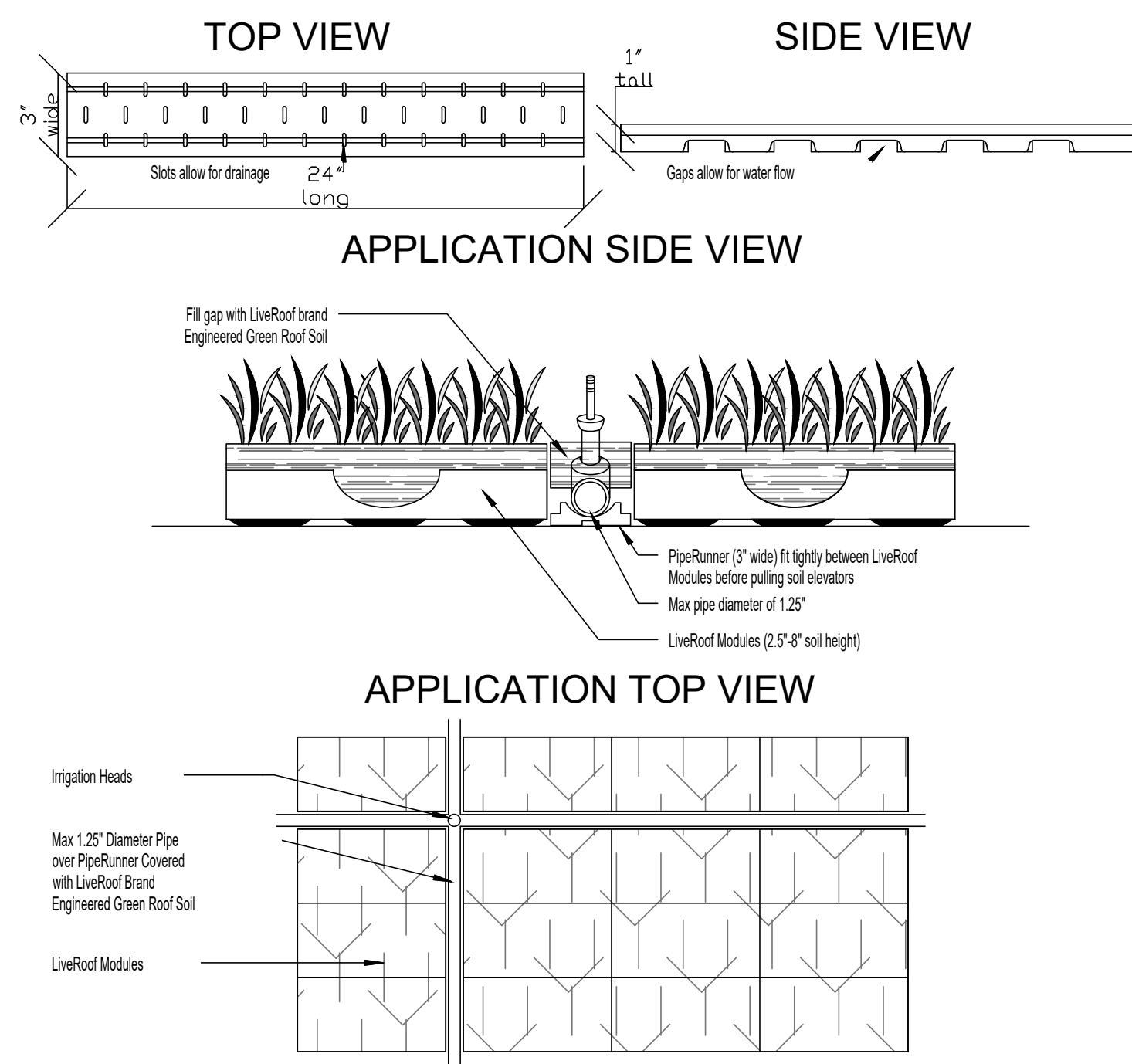

HOTEL REDEVELOPMENT
155 PORTER STREET, EAST BOSTON, MA

PROJECT: HUDSON 62 REALTY LLC
APPLICANT: 440 BEDFORD ST, LEXINGTON, MA 01824

REVISIONS

REV.	DATE	DESCRIPTION
1	06-09-2021	NATIVE PLANTS

06/09/21

100% CONSTRUCTION DOCUMENTS
JANUARY 2, 2020

GREEN ROOF LANDSCAPE DETAILS

SCALE:	NOT TO SCALE
JOB NO:	1916
FILE:	1916-L.dwg
DRAWN:	RAB
CHECKED:	RAB
SHEET NO:	L201