

April 16, 2021

NOTICE OF INTENT

Under the *Wetlands Protection Act* (M.G.L. c. 131, §40
and their Regulations (310 CMR 10.00),
and the City of Boston Wetlands Permit Requirements

For

2 HARBOR STREET

2 Harbor Street
Boston, MA 02

Prepared for:

HANDEL ARCHITECTS
69 Canal Street, 2nd Floor
Boston, MA 02114

Prepared by:

NITSCH ENGINEERING, INC.
2 Center Plaza, Suite 430
Boston, MA 02108

Nitsch Project #13569

TABLE OF CONTENTS

Section 1	Notice of Intent Forms WPA Form 3 - Notice of Intent NOI Wetland Fee Transmittal Form Boston Notice of Intent Application Form Copy of Checks (Local and State Filing Fees)
Section 2	Project Narrative
Section 3	Documentation of Abutter Notification Abutter Notification (English) Abutter Notification (Chinese) Babel Notice Affidavit of Service Certified Abutters List
Figures	Figure 1 – USGS Locus Map Figure 2 – Aerial Locus Map Figure 3 – FEMA Floodplain Map Figure 4 – Natural Heritage and Endangered Species Program Map
Plans	Existing Conditions Plan, prepared by Feldman Land Surveyors Site Demolition Plan, Sedimentation and Erosion Control Plan, Site Utility Plan, Site Layout Plan, and Civil Details, prepared by Nitsch Engineering Materials Plan, Grading Plan, Planting Plan, and Details, prepared by Klopfer Martin Design Group

2 Harbor Street
Boston, Massachusetts

Notice of Intent

SECTION 1

NOTICE OF INTENT FORMS

WPA Form 3 - Notice of Intent
NOI Wetland Fee Transmittal Form
Boston Notice of Intent Application Form
Copy of Checks (Local and State Filing Fees)



Massachusetts Department of Environmental Protection
Bureau of Resource Protection - Wetlands

WPA Form 3 – Notice of Intent

Massachusetts Wetlands Protection Act M.G.L. c. 131, §40

Provided by MassDEP:

MassDEP File Number

Document Transaction Number

Boston
City/Town

Important:

When filling out forms on the computer, use only the tab key to move your cursor - do not use the return key.



Note:
Before completing this form consult your local Conservation Commission regarding any municipal bylaw or ordinance.

A. General Information

1. Project Location (**Note:** electronic filers will click on button to locate project site):

2 Harbor Street

a. Street Address

Boston

b. City/Town

02210

c. Zip Code

Latitude and Longitude:

06

f. Assessors Map/Plat Number

42.3450

d. Latitude

-71.0369

e. Longitude

02674115

g. Parcel /Lot Number

2. Applicant:

Eric

a. First Name

Ewer

b. Last Name

Beacon Capital Partners

c. Organization

200 State Street

d. Street Address

Boston

e. City/Town

MA

f. State

02109

g. Zip Code

617-293-8311

h. Phone Number

i. Fax Number

eewer@beaconcapital.com

j. Email Address

3. Property owner (required if different from applicant): Check if more than one owner

Devin

a. First Name

Quirk

b. Last Name

Economic Development Industrial Corporation c/o BPDA

c. Organization

Boston City Hall, 1 City Hall Square, 9th Floor

d. Street Address

Boston

e. City/Town

MA

f. State

02201

g. Zip Code

617-918-4431

h. Phone Number

i. Fax Number

devin.quirk@boston.gov

j. Email address

4. Representative (if any):

Chris

a. First Name

Hodney

b. Last Name

Nitsch Engineering

c. Company

2 Center Plaza, Suite 430

d. Street Address

Boston

e. City/Town

MA

f. State

02108

g. Zip Code

857-206-8673

h. Phone Number

i. Fax Number

chodney@nitscheng.com

j. Email address

5. Total WPA Fee Paid (from NOI Wetland Fee Transmittal Form):

\$1,050

a. Total Fee Paid

\$512.50

b. State Fee Paid

\$2,050 (City Ordinance)

c. City/Town Fee Paid



Massachusetts Department of Environmental Protection
Bureau of Resource Protection - Wetlands

WPA Form 3 – Notice of Intent

Massachusetts Wetlands Protection Act M.G.L. c. 131, §40

Provided by MassDEP:
MassDEP File Number
Document Transaction Number
City/Town

A. General Information (continued)

6. General Project Description:

The existing project site contains a warehouse building and surface parking lot for freight trucks. The building is currently being demolished under an emergency order after being damaged in a storm. The proposed project will consist of the construction of a new lab/office building, surface parking lot, site improvements, and utility improvements. A new stormwater management system will be installed as part of this project.

7a. Project Type Checklist: (Limited Project Types see Section A. 7b.)

- 1. Single Family Home
- 2. Residential Subdivision
- 3. Commercial/Industrial
- 4. Dock/Pier
- 5. Utilities
- 6. Coastal engineering Structure
- 7. Agriculture (e.g., cranberries, forestry)
- 8. Transportation
- 9. Other

7b. Is any portion of the proposed activity eligible to be treated as a limited project (including Ecological Restoration Limited Project) subject to 310 CMR 10.24 (coastal) or 310 CMR 10.53 (inland)?

1. Yes No If yes, describe which limited project applies to this project. (See 310 CMR 10.24 and 10.53 for a complete list and description of limited project types)

2. Limited Project Type

If the proposed activity is eligible to be treated as an Ecological Restoration Limited Project (310 CMR10.24(8), 310 CMR 10.53(4)), complete and attach Appendix A: Ecological Restoration Limited Project Checklist and Signed Certification.

8. Property recorded at the Registry of Deeds for:

Suffolk	
a. County	b. Certificate # (if registered land)
8960	484
c. Book	d. Page Number

B. Buffer Zone & Resource Area Impacts (temporary & permanent)

- 1. Buffer Zone Only – Check if the project is located only in the Buffer Zone of a Bordering Vegetated Wetland, Inland Bank, or Coastal Resource Area.
- 2. Inland Resource Areas (see 310 CMR 10.54-10.58; if not applicable, go to Section B.3, Coastal Resource Areas).

Check all that apply below. Attach narrative and any supporting documentation describing how the project will meet all performance standards for each of the resource areas altered, including standards requiring consideration of alternative project design or location.



Massachusetts Department of Environmental Protection
Bureau of Resource Protection - Wetlands

WPA Form 3 – Notice of Intent

Massachusetts Wetlands Protection Act M.G.L. c. 131, §40

Provided by MassDEP:

MassDEP File Number

Document Transaction Number

City/Town

B. Buffer Zone & Resource Area Impacts (temporary & permanent) (cont'd)

For all projects affecting other Resource Areas, please attach a narrative explaining how the resource area was delineated.

Resource Area	Size of Proposed Alteration	Proposed Replacement (if any)
a. <input type="checkbox"/> Bank	1. linear feet	2. linear feet
b. <input type="checkbox"/> Bordering Vegetated Wetland	1. square feet	2. square feet
c. <input type="checkbox"/> Land Under Waterbodies and Waterways	1. square feet	2. square feet
	3. cubic yards dredged	

Resource Area	Size of Proposed Alteration	Proposed Replacement (if any)
d. <input type="checkbox"/> Bordering Land Subject to Flooding	1. square feet	2. square feet
	3. cubic feet of flood storage lost	4. cubic feet replaced
e. <input type="checkbox"/> Isolated Land Subject to Flooding	1. square feet	
	2. cubic feet of flood storage lost	3. cubic feet replaced

- f. Riverfront Area
1. Name of Waterway (if available) - **specify coastal or inland**
2. Width of Riverfront Area (check one):
- 25 ft. - Designated Densely Developed Areas only
 - 100 ft. - New agricultural projects only
 - 200 ft. - All other projects

3. Total area of Riverfront Area on the site of the proposed project: _____ square feet

4. Proposed alteration of the Riverfront Area:

_____	_____	_____
a. total square feet	b. square feet within 100 ft.	c. square feet between 100 ft. and 200 ft.

5. Has an alternatives analysis been done and is it attached to this NOI? Yes No

6. Was the lot where the activity is proposed created prior to August 1, 1996? Yes No

3. Coastal Resource Areas: (See 310 CMR 10.25-10.35)

Note: for coastal riverfront areas, please complete **Section B.2.f.** above.



Massachusetts Department of Environmental Protection
Bureau of Resource Protection - Wetlands

WPA Form 3 – Notice of Intent

Massachusetts Wetlands Protection Act M.G.L. c. 131, §40

Provided by MassDEP:
MassDEP File Number
Document Transaction Number
City/Town

B. Buffer Zone & Resource Area Impacts (temporary & permanent) (cont'd)

Check all that apply below. Attach narrative and supporting documentation describing how the project will meet all performance standards for each of the resource areas altered, including standards requiring consideration of alternative project design or location.

Online Users:
Include your document transaction number (provided on your receipt page) with all supplementary information you submit to the Department.

Resource Area	Size of Proposed Alteration	Proposed Replacement (if any)
a. <input type="checkbox"/> Designated Port Areas	Indicate size under Land Under the Ocean, below	
b. <input type="checkbox"/> Land Under the Ocean	_____	
	1. square feet	

	2. cubic yards dredged	
c. <input type="checkbox"/> Barrier Beach	Indicate size under Coastal Beaches and/or Coastal Dunes below	
d. <input type="checkbox"/> Coastal Beaches	_____	_____
	1. square feet	2. cubic yards beach nourishment
e. <input type="checkbox"/> Coastal Dunes	_____	_____
	1. square feet	2. cubic yards dune nourishment
	Size of Proposed Alteration	Proposed Replacement (if any)
f. <input type="checkbox"/> Coastal Banks	_____	
	1. linear feet	
g. <input type="checkbox"/> Rocky Intertidal Shores	_____	
	1. square feet	
h. <input type="checkbox"/> Salt Marshes	_____	_____
	1. square feet	2. sq ft restoration, rehab., creation
i. <input type="checkbox"/> Land Under Salt Ponds	_____	
	1. square feet	

	2. cubic yards dredged	
j. <input type="checkbox"/> Land Containing Shellfish	_____	
	1. square feet	
k. <input type="checkbox"/> Fish Runs	Indicate size under Coastal Banks, inland Bank, Land Under the Ocean, and/or inland Land Under Waterbodies and Waterways, above	

	1. cubic yards dredged	
l. <input checked="" type="checkbox"/> Land Subject to Coastal Storm Flowage	_____	
	185,700	

	1. square feet	
4. <input type="checkbox"/> Restoration/Enhancement	If the project is for the purpose of restoring or enhancing a wetland resource area in addition to the square footage that has been entered in Section B.2.b or B.3.h above, please enter the additional amount here.	
	_____	_____
	a. square feet of BVW	b. square feet of Salt Marsh
5. <input type="checkbox"/> Project Involves Stream Crossings		
	_____	_____
	a. number of new stream crossings	b. number of replacement stream crossings



Massachusetts Department of Environmental Protection
Bureau of Resource Protection - Wetlands

WPA Form 3 – Notice of Intent

Massachusetts Wetlands Protection Act M.G.L. c. 131, §40

Provided by MassDEP:

MassDEP File Number

Document Transaction Number

City/Town

C. Other Applicable Standards and Requirements

— This is a proposal for an Ecological Restoration Limited Project. Skip Section C and complete Appendix A: Ecological Restoration Limited Project Checklists – Required Actions (310 CMR 10.11).

Streamlined Massachusetts Endangered Species Act/Wetlands Protection Act Review

1. Is any portion of the proposed project located in **Estimated Habitat of Rare Wildlife** as indicated on the most recent Estimated Habitat Map of State-Listed Rare Wetland Wildlife published by the Natural Heritage and Endangered Species Program (NHESP)? To view habitat maps, see the *Massachusetts Natural Heritage Atlas* or go to http://maps.massgis.state.ma.us/PRI_EST_HAB/viewer.htm.

a. Yes No **If yes, include proof of mailing or hand delivery of NOI to:**

**Natural Heritage and Endangered Species Program
Division of Fisheries and Wildlife
1 Rabbit Hill Road
Westborough, MA 01581**

b. Date of map _____

If yes, the project is also subject to Massachusetts Endangered Species Act (MESA) review (321 CMR 10.18). To qualify for a streamlined, 30-day, MESA/Wetlands Protection Act review, please complete Section C.1.c, and include requested materials with this Notice of Intent (NOI); *OR* complete Section C.2.f, if applicable. *If MESA supplemental information is not included with the NOI, by completing Section 1 of this form, the NHESP will require a separate MESA filing which may take up to 90 days to review (unless noted exceptions in Section 2 apply, see below).*

c. Submit Supplemental Information for Endangered Species Review*

1. Percentage/acreage of property to be altered:
 - (a) within wetland Resource Area _____ percentage/acreage
 - (b) outside Resource Area _____ percentage/acreage

2. Assessor's Map or right-of-way plan of site

2. Project plans for entire project site, including wetland resource areas and areas outside of wetlands jurisdiction, showing existing and proposed conditions, existing and proposed tree/vegetation clearing line, and clearly demarcated limits of work **
 - (a) Project description (including description of impacts outside of wetland resource area & buffer zone)
 - (b) Photographs representative of the site

* Some projects **not** in Estimated Habitat may be located in Priority Habitat, and require NHESP review (see <https://www.mass.gov/endangered-species-act-mesa-regulatory-review>).

Priority Habitat includes habitat for state-listed plants and strictly upland species not protected by the Wetlands Protection Act.

** MESA projects may not be segmented (321 CMR 10.16). The applicant must disclose full development plans even if such plans are not required as part of the Notice of Intent process.



Massachusetts Department of Environmental Protection
Bureau of Resource Protection - Wetlands

WPA Form 3 – Notice of Intent

Massachusetts Wetlands Protection Act M.G.L. c. 131, §40

Provided by MassDEP:
MassDEP File Number
Document Transaction Number
City/Town

C. Other Applicable Standards and Requirements (cont'd)

(c) MESA filing fee (fee information available at <https://www.mass.gov/how-to/how-to-file-for-a-mesa-project-review>).

Make check payable to "Commonwealth of Massachusetts - NHESP" and **mail to NHESP** at above address

Projects altering 10 or more acres of land, also submit:

(d) Vegetation cover type map of site

(e) Project plans showing Priority & Estimated Habitat boundaries

(f) OR Check One of the Following

1. Project is exempt from MESA review.
Attach applicant letter indicating which MESA exemption applies. (See 321 CMR 10.14, <https://www.mass.gov/service-details/exemptions-from-review-for-projectsactivities-in-priority-habitat>; the NOI must still be sent to NHESP if the project is within estimated habitat pursuant to 310 CMR 10.37 and 10.59.)

2. Separate MESA review ongoing. a. NHESP Tracking # _____ b. Date submitted to NHESP _____

3. Separate MESA review completed.
Include copy of NHESP "no Take" determination or valid Conservation & Management Permit with approved plan.

3. For coastal projects only, is any portion of the proposed project located below the mean high water line or in a fish run?

a. Not applicable – project is in inland resource area only b. Yes No

If yes, include proof of mailing, hand delivery, or electronic delivery of NOI to either:

South Shore - Cohasset to Rhode Island border, and the Cape & Islands:

North Shore - Hull to New Hampshire border:

Division of Marine Fisheries -
Southeast Marine Fisheries Station
Attn: Environmental Reviewer
836 South Rodney French Blvd.
New Bedford, MA 02744
Email: dmf.envreview-south@mass.gov

Division of Marine Fisheries -
North Shore Office
Attn: Environmental Reviewer
30 Emerson Avenue
Gloucester, MA 01930
Email: dmf.envreview-north@mass.gov

Also if yes, the project may require a Chapter 91 license. For coastal towns in the Northeast Region, please contact MassDEP's Boston Office. For coastal towns in the Southeast Region, please contact MassDEP's Southeast Regional Office.

c. Is this an aquaculture project? d. Yes No

If yes, include a copy of the Division of Marine Fisheries Certification Letter (M.G.L. c. 130, § 57).



Massachusetts Department of Environmental Protection
Bureau of Resource Protection - Wetlands

WPA Form 3 – Notice of Intent

Massachusetts Wetlands Protection Act M.G.L. c. 131, §40

Provided by MassDEP:
MassDEP File Number
Document Transaction Number
City/Town

Online Users:
Include your document transaction number (provided on your receipt page) with all supplementary information you submit to the Department.

C. Other Applicable Standards and Requirements (cont'd)

4. Is any portion of the proposed project within an Area of Critical Environmental Concern (ACEC)?
 a. Yes No If yes, provide name of ACEC (see instructions to WPA Form 3 or MassDEP Website for ACEC locations). **Note:** electronic filers click on Website.
 b. ACEC
5. Is any portion of the proposed project within an area designated as an Outstanding Resource Water (ORW) as designated in the Massachusetts Surface Water Quality Standards, 314 CMR 4.00?
 a. Yes No
6. Is any portion of the site subject to a Wetlands Restriction Order under the Inland Wetlands Restriction Act (M.G.L. c. 131, § 40A) or the Coastal Wetlands Restriction Act (M.G.L. c. 130, § 105)?
 a. Yes No
7. Is this project subject to provisions of the MassDEP Stormwater Management Standards?
 a. Yes. Attach a copy of the Stormwater Report as required by the Stormwater Management Standards per 310 CMR 10.05(6)(k)-(q) and check if:
 1. Applying for Low Impact Development (LID) site design credits (as described in Stormwater Management Handbook Vol. 2, Chapter 3)
 2. A portion of the site constitutes redevelopment
 3. Proprietary BMPs are included in the Stormwater Management System.
 b. No. Check why the project is exempt:
 1. Single-family house
 2. Emergency road repair
 3. Small Residential Subdivision (less than or equal to 4 single-family houses or less than or equal to 4 units in multi-family housing project) with no discharge to Critical Areas.

D. Additional Information

- This is a proposal for an Ecological Restoration Limited Project. Skip Section D and complete Appendix A: Ecological Restoration Notice of Intent – Minimum Required Documents (310 CMR 10.12).

Applicants must include the following with this Notice of Intent (NOI). See instructions for details.

Online Users: Attach the document transaction number (provided on your receipt page) for any of the following information you submit to the Department.

- USGS or other map of the area (along with a narrative description, if necessary) containing sufficient information for the Conservation Commission and the Department to locate the site. (Electronic filers may omit this item.)
- Plans identifying the location of proposed activities (including activities proposed to serve as a Bordering Vegetated Wetland [BVW] replication area or other mitigating measure) relative to the boundaries of each affected resource area.



Massachusetts Department of Environmental Protection
Bureau of Resource Protection - Wetlands

WPA Form 3 – Notice of Intent

Massachusetts Wetlands Protection Act M.G.L. c. 131, §40

Provided by MassDEP:

MassDEP File Number

Document Transaction Number

City/Town

F. Signatures and Submittal Requirements

I hereby certify under the penalties of perjury that the foregoing Notice of Intent and accompanying plans, documents, and supporting data are true and complete to the best of my knowledge. I understand that the Conservation Commission will place notification of this Notice in a local newspaper at the expense of the applicant in accordance with the wetlands regulations, 310 CMR 10.05(5)(a).

I further certify under penalties of perjury that all abutters were notified of this application, pursuant to the requirements of M.G.L. c. 131, § 40. Notice must be made by Certificate of Mailing or in writing by hand delivery or certified mail (return receipt requested) to all abutters within 100 feet of the property line of the project location.

	4/6/21
1. Signature of Applicant	2. Date
	4/23/21
3. Signature of Property Owner (if different)	4. Date
	4/16/2021
5. Signature of Representative (if any)	6. Date

For Conservation Commission:

Two copies of the completed Notice of Intent (Form 3), including supporting plans and documents, two copies of the NOI Wetland Fee Transmittal Form, and the city/town fee payment, to the Conservation Commission by certified mail or hand delivery.

For MassDEP:

One copy of the completed Notice of Intent (Form 3), including supporting plans and documents, one copy of the NOI Wetland Fee Transmittal Form, and a **copy** of the state fee payment to the MassDEP Regional Office (see Instructions) by certified mail or hand delivery.

Other:

If the applicant has checked the "yes" box in any part of Section C, Item 3, above, refer to that section and the Instructions for additional submittal requirements.

The original and copies must be sent simultaneously. Failure by the applicant to send copies in a timely manner may result in dismissal of the Notice of Intent.



Massachusetts Department of Environmental Protection
 Bureau of Resource Protection - Wetlands
NOI Wetland Fee Transmittal Form
 Massachusetts Wetlands Protection Act M.G.L. c. 131, §40

Important: When filling out forms on the computer, use only the tab key to move your cursor - do not use the return key.



A. Applicant Information

1. Location of Project:

2 Harbor Street

a. Street Address

Boston

b. City/Town

\$1,050 (Per State) \$2,562.5 (per City Ordinance)

d. Fee amount

c. Check number

2. Applicant Mailing Address:

Eric

a. First Name

Ewer

b. Last Name

Beacon Capital

c. Organization

200 State Street

d. Mailing Address

Boston

e. City/Town

MA

f. State

02109

g. Zip Code

617-293-8311

h. Phone Number

i. Fax Number

eeewer@beaconcapital.com

j. Email Address

3. Property Owner (if different):

Devin

a. First Name

Quirk

b. Last Name

Economic Development Industrial Corporation c/o BPDA

c. Organization

Boston City Hall, 1 City Hall Square, 9th Floor

d. Mailing Address

Boston

e. City/Town

MA

f. State

02201

g. Zip Code

617-918-4431

h. Phone Number

i. Fax Number

devin.quirk@boston.gov

j. Email Address

To calculate filing fees, refer to the category fee list and examples in the instructions for filling out WPA Form 3 (Notice of Intent).

B. Fees

Fee should be calculated using the following process & worksheet. **Please see Instructions before filling out worksheet.**

Step 1/Type of Activity: Describe each type of activity that will occur in wetland resource area and buffer zone.

Step 2/Number of Activities: Identify the number of each type of activity.

Step 3/Individual Activity Fee: Identify each activity fee from the six project categories listed in the instructions.

Step 4/Subtotal Activity Fee: Multiply the number of activities (identified in Step 2) times the fee per category (identified in Step 3) to reach a subtotal fee amount. Note: If any of these activities are in a Riverfront Area in addition to another Resource Area or the Buffer Zone, the fee per activity should be multiplied by 1.5 and then added to the subtotal amount.

Step 5/Total Project Fee: Determine the total project fee by adding the subtotal amounts from Step 4.

Step 6/Fee Payments: To calculate the state share of the fee, divide the total fee in half and subtract \$12.50. To calculate the city/town share of the fee, divide the total fee in half and add \$12.50.



INSTRUCTIONS FOR COMPLETING APPLICATION NOTICE OF INTENT – BOSTON NOI FORM

The Boston Notice of Intent Form is intended to be a supplement to the WPA Form 3 detailing impacts to locally designated wetland resource areas and buffer zones. Please read these instructions for assistance in completing the Notice of Intent application form. These instructions cover certain items on the Notice of Intent form that are not self-explanatory.

INSTRUCTIONS TO SECTION B: BUFFER ZONE AND RESOURCE AREA IMPACTS

Item 1. Buffer Zone Only. If you check the Buffer Zone Only box in this section you are indicating that the project is entirely in the Buffer Zone to a resource area **under both** the Wetlands Protection Act and Boston Wetlands Ordinance. If so, skip the remainder of Section B and go directly to Section C. Do not check this box if the project is within the Waterfront Area.

Item 2. The **boundaries of coastal resource areas** specific to the Ordinance can be found in Section II of the Boston Wetlands Regulations. You must also include the size of the proposed alterations (and proposed replacement areas) in each resource area.

Item 3. The **boundaries of inland resource areas** specific to the Ordinance can be found in Section II of the Boston Wetlands Regulations. You must also include the size of the proposed alterations (and proposed replacement areas) in each resource area.

INSTRUCTIONS TO SECTION C: OTHER APPLICABLE STANDARDS AND REQUIREMENTS

Item 1. Rare Wetland Wildlife Habitat. Except for Designated Port Areas, no work (including work in the Buffer Zone) may be permitted in any resource area that would have adverse effects on the habitat of rare, “state-listed” vertebrate or invertebrate animal species.

The most recent Estimated Habitat Map of State-Listed Rare Wetland Wildlife is published by the Natural Heritage and Endangered Species Program (NHESP). See: http://maps.massgis.state.ma.us/PRI_EST_HAB/viewer.htm or the *Massachusetts Natural Heritage Atlas*.

If any portion of the proposed project is located within Estimated Habitat, the applicant must send the Natural Heritage Program, at the following address, a copy of the Notice of Intent by certified mail or priority mail (or otherwise sent in a manner that guarantees delivery within two days), no later than the date of the filing of the Notice of Intent with the Conservation Commission.

Evidence of mailing to the Natural Heritage Program (such as Certified Mail Receipt or Certificate of Mailing for Priority Mail) must be submitted to the Conservation Commission along with the Notice of Intent.

Natural Heritage and Endangered Species Program
Division of Fisheries and Wildlife
1 Rabbit Hill Road
Westborough, MA 01581-3336
508.792.7270



A. GENERAL INFORMATION

1. Project Location

2 Harbor Street Boston 02210
a. Street Address b. City/Town c. Zip Code

06 02674115
f. Assessors Map/Plat Number g. Parcel /Lot Number

2. Applicant

Eric Ewer Beacon Capital Partners
a. First Name b. Last Name c. Company

200 State Street
d. Mailing Address

Boston MA 02109
e. City/Town f. State g. Zip Code

617-293-8311 eewer@beaconcapital.com
h. Phone Number i. Fax Number j. Email address

3. Property Owner

Devin Quirk Economic Development Industrial Corporation c/o BPDA
a. First Name b. Last Name c. Company

Boston City Hall, 1 City Hall Square, 9th Floor
d. Mailing Address

Boston MA 02201
e. City/Town f. State g. Zip Code

617-918-4431 devin.quirk@boston.gov
h. Phone Number i. Fax Number j. Email address

Check if more than one owner

(If there is more than one property owner, please attach a list of these property owners to this form.)

4. Representative (if any)

Chris Hodney Nitsch Engineering
a. First Name b. Last Name c. Company

2 Center Plaza, Suite 430
d. Mailing Address

Boston MA 02108
e. City/Town f. State g. Zip Code

857-206-8673 chodney@nitscheng.com
h. Phone Number i. Fax Number j. Email address



5. Is any portion of the proposed project jurisdictional under the Massachusetts Wetlands Protection Act M.G.L. c. 131 §40?

- Yes No

If yes, please file the WPA Form 3 - Notice of Intent with this form

6. General Information

The existing project site contains a warehouse building and surface parking lot for freight trucks. The building is currently being demolished under an emergency order after being damaged in a storm. The proposed project will consist of the construction of a new lab/office building, surface parking lot, site improvements, and utility improvements. A new stormwater management system will be installed as part of this project.

7. Project Type Checklist

- a. Single Family Home
- b. Residential Subdivision
- c. Limited Project Driveway Crossing
- d. Commercial/Industrial
- e. Dock/Pier
- f. Utilities
- g. Coastal Engineering Structure
- h. Agriculture – cranberries, forestry
- i. Transportation
- j. Other

8. Property recorded at the Registry of Deeds

<u>Suffolk</u>	<u>484</u>
a. County	b. Page Number
<u>8960</u>	_____
c. Book	d. Certificate # (if registered land)

9. Total Fee Paid

<u>\$2,562.50</u>	<u>\$512.50</u>	<u>\$2,050 (City Ordinance)</u>
a. Total Fee Paid	b. State Fee Paid	c. City Fee Paid

B. BUFFER ZONE & RESOURCE AREA IMPACTS

Buffer Zone Only - Is the project located only in the Buffer Zone of a resource area protected by the Boston Wetlands Ordinance?

- Yes No

1. Coastal Resource Areas



<u>Resource Area</u>	<u>Resource Area Size</u>	<u>Proposed Alteration*</u>	<u>Proposed Mitigation</u>
<input type="checkbox"/> Coastal Flood Resilience Zone	_____	_____	_____
	Square feet	Square feet	Square feet
<input type="checkbox"/> 25-foot Waterfront Area	_____	_____	_____
	Square feet	Square feet	Square feet
<input type="checkbox"/> 100-foot Salt Marsh Area	_____	_____	_____
	Square feet	Square feet	Square feet
<input type="checkbox"/> Riverfront Area	_____	_____	_____
	Square feet	Square feet	Square feet

2. Inland Resource Areas

<u>Resource Area</u>	<u>Resource Area Size</u>	<u>Proposed Alteration*</u>	<u>Proposed Mitigation</u>
<input type="checkbox"/> Inland Flood Resilience Zone	_____	_____	_____
	Square feet	Square feet	Square feet
<input type="checkbox"/> Isolated Wetlands	_____	_____	_____
	Square feet	Square feet	Square feet
<input type="checkbox"/> Vernal Pool	_____	_____	_____
	Square feet	Square feet	Square feet
<input type="checkbox"/> Vernal Pool Habitat (vernal pool + 100 ft. upland area)	_____	_____	_____
	Square feet	Square feet	Square feet
<input type="checkbox"/> 25-foot Waterfront Area	_____	_____	_____
	Square feet	Square feet	Square feet
<input type="checkbox"/> Riverfront Area	_____	_____	_____
	Square feet	Square feet	Square feet

C. OTHER APPLICABLE STANDARDS & REQUIREMENTS

1. What other permits, variances, or approvals are required for the proposed activity described herein and what is the status of such permits, variances, or approvals?

Site Plan Approval is required from the Boston Water and Sewer Commission (BWSC). Nitsch submitted to BWSC on April 21, 2021.



2. Is any portion of the proposed project located in Estimated Habitat of Rare Wildlife as indicated on the most recent Estimated Habitat Map of State-Listed Rare Wetland Wildlife published by the Natural Heritage and Endangered Species Program (NHESP)? To view habitat maps, see the Massachusetts Natural Heritage Atlas or go to <http://www.mass.gov/dfwele/dfw/nhosp/nhregmap.htm>.

- Yes No

If yes, the project is subject to Massachusetts Endangered Species Act (MESA) review (321 CMR 10.18).

A. Submit Supplemental Information for Endangered Species Review

Percentage/acreage of property to be altered:

(1) within wetland Resource Area _____ percentage/acreage

(2) outside Resource Area _____ percentage/acreage

Assessor's Map or right-of-way plan of site

3. Is any portion of the proposed project within an Area of Critical Environmental Concern?

- Yes No

If yes, provide the name of the ACEC: _____

4. Is the proposed project subject to provisions of the Massachusetts Stormwater Management Standards?

Yes. Attach a copy of the Stormwater Checklist & Stormwater Report as required.

Applying for a Low Impact Development (LID) site design credits

A portion of the site constitutes redevelopment

Proprietary BMPs are included in the Stormwater Management System

No. Check below & include a narrative as to why the project is exempt

Single-family house

Emergency road repair

Small Residential Subdivision (less than or equal to 4 single family houses or less than or equal to 4 units in a multifamily housing projects) with no discharge to Critical Areas

5. Is the proposed project subject to Boston Water and Sewer Commission Review?

- Yes No



D. SIGNATURES AND SUBMITTAL REQUIREMENTS

I hereby certify under the penalties of perjury that the foregoing Notice of Intent and accompanying plans, documents, and supporting data are true and complete to the best of my knowledge. I understand that the Conservation Commission will place notification of this Notice in a local newspaper at the expense of the applicant in accordance with the Wetlands Protection Ordinance.



Signature of Applicant

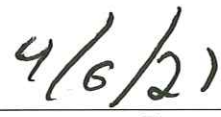

Date



Signature of Property Owner (if different)

4/23/21

Date

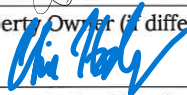

Signature of Representative (if any)

4/16/2021

Date

SECTION 2
PROJECT NARRATIVE

PROJECT NARRATIVE CONTENTS

1.0 EXECUTIVE SUMMARY	1
2.0 EXISTING CONDITIONS.....	1
2.1 Existing Site Description	1
2.2 Wetland Resource Areas	Error! Bookmark not defined.
2.3 Other Environmental Considerations.....	2
FEMA Flood Zone	2
NHESP Priority and Estimated Habitat.....	2
Total Maximum Daily Load.....	2
3.0 PROPOSED CONDITIONS	2
3.1 Overview of Proposed Work	2
3.2 Snow Removal.....	Error! Bookmark not defined.
4.0 WETLAND RESOURCE AREA IMPACTS	3
4.1 Proposed Work Within Bordering Land Subject to Flooding.....	Error! Bookmark not defined.
5.0 PROPOSED MITIGATION MEASURES.....	3
5.1 Pavement Removal.....	Error! Bookmark not defined.
5.2 Removal of Debris Piles.....	Error! Bookmark not defined.
5.3 Construction Period Erosion and Sedimentation Controls.....	3
5.4 Post-Construction Stormwater Management.....	4
5.5 Long-Term Pollution Prevention.....	4
6.0 INTERESTS OF THE WETLANDS PROTECTION ACT	ERROR! BOOKMARK NOT DEFINED.
7.0 CONCLUSION.....	4

1.0 EXECUTIVE SUMMARY

On behalf of the Applicant, Beacon Capital Partners, Nitsch Engineering, Inc. is filing the enclosed Notice of Intent (NOI) with the Boston Conservation Commission for the proposed construction improvements, which are located within the FEMA Flood Insurance Rate Map Zone AE, which is Land Subject to Coastal Storm Flowage (LSCF). The purpose of this NOI Application is to receive an Order of Conditions from the Boston Conservation Commission approving the proposed project under the *Wetlands Protection Act* (M.G.L. c. 131, §40) and their Regulations (310 CMR 10.00), City of Boston Ordinance Protecting Local Wetlands and Promoting Climate Change Adaption in the City of Boston.

The Project site is located at 2 Harbor Street, Massachusetts. The Project consists of the construction of a 53,600 square-foot building and various site improvements, including a new access driveway/roadways, parking lot, utility work, and a new stormwater management system.

The site is located within the Land Subject to Coastal Storm Flowage designation.

The proposed site improvements within the Land Subject to Coastal Storm Flowage include:

- Parking lot;
- Access driveway;
- Pedestrian impervious areas and porous paver areas;
- Sewer, drainage, water, gas and electric utilities;
- Landscaping; and
- Associated earthwork and revegetation.

The Project includes several mitigation measures to offset the impacts including reduction in impervious area onsite, construction of a stormwater management system, and construction period erosion and sedimentation controls. These mitigation measures are further discussed in the narrative below.

2.0 EXISTING CONDITIONS

2.1 Existing Site Description

The 4.4-acre Project site is located at 2 Harbor Street in Boston, Massachusetts (Figure 1 – USGS Locus Map and Figure 2 – Aerial Locus Map). The site is bounded by Northern Ave to the North, Harbor Street to the East, private properties to the south, and Massport Haul Road to the west.

The entirety of the existing site is developed and contains a 71,000± square-foot warehouse building with associated driveways, parking, and utilities. The building was demolished in April 2021 under an Emergency Order from the Boston Fire Department because it was damaged during a storm and determined to be unsafe. The analysis for the site includes the assumption that the existing condition is as documented in the survey with the building still in place. The existing site is approximately 98% impervious. The site elevations range from approximately elevation 16 Boston City Base (BCB) to 20.3 BCB.

The existing Site is serviced by electric, sanitary sewer, gas, water, and storm drain utilities which connect to the mains in Harbor Street and Northern Avenue.

2.2 Resource Areas

FEMA Flood Zone

Based on the FEMA Flood Insurance Rate Maps for Boston (Community Panel Number 25025C0081J), the Project site is located within regulated flood zone including the 100-year floodplain with a flood elevation of Elevation 10 NAVD (16.46 BCB). The site is within Land Subject to Coastal Storm Flowage.

2.3 Environmental Considerations

NHESP Priority and Estimated Habitat

Based on the MASSGIS data layers for the 14th Edition of the Natural Heritage Atlas, effective August 1, 2017, the Project site is not located within designated Estimated Habitat of Rare Wildlife or Priority Habitat of Rare Species and does not contain any Certified Vernal Pools (Figure 4 – Natural Heritage and Endangered Species Program Map).

Total Maximum Daily Load

The project is located within the Boston Harbor watershed. Boston Harbor is listed as impaired under section 303(d) of the Clean Water Act due to pathogens and PCBs. There is not Final Pollutant Total Maximum Daily Load] (TMDL) for the Boston Harbor Watershed. The Project has been designed to infiltrate stormwater runoff which will help to reduce the pathogen pollutant loading.

3.0 PROPOSED CONDITIONS

3.1 Overview of Proposed Work

The Project is proposing the construction of a new office and laboratory building with associated parking lots, walkways, and utilities (including water, sewer, drain, gas, electric, and telecom services). The proposed project will result in a net decrease in overall impervious area (building and pavement) of 25,310 square feet (0.6 acres) (Table 2).

Table 2. Existing and proposed land cover type for the Project

Land Use	Existing (SF)	Proposed (SF)	Change
Buildings	70,800	53,650	-17,150
Site Impervious Area	116,030	93,780	-22,250
Permeable Pavers/Pavement	-	14,090	+14,090
Vegetation	3,160	28,470	+25,310
Total	189,990	189,990	---

The proposed project also includes the installation of a new stormwater management system that was designed in accordance with the MassDEP Stormwater Management Standards and the Boston Water and Sewer Commission requirements. Best Management Practices (BMPs) will be used to mitigate changes in runoff, promote infiltration, and provide water quality treatment. The Project will also implement long-term pollution prevention and source control measures, including inspections

and maintenance of stormwater BMPs. Refer to the enclosed Stormwater Report for additional information on the proposed stormwater management system.

3.2 Building Design and Infrastructure

The Boston Planning and Development Agency has determined a Sea Level Rise Base Flood Elevation (SLR-BFE) of 19.5 ft (BCB) for the 2 Harbor Street parcel which is above the FEMA flood elevation of 16.46 BCB. The proposed building's use requires 1-foot of freeboard above SLR-BFE for the design flood elevation which would be 20.50 BCB for this site. The building's proposed first floor elevation is 20.75 Boston City Base (BCB) which is above the current FEMA flood elevation and the SLR-BFE.

The building's main electrical room and transformer vault as well as air handling and condensing units are located above elevation 20.50 BCB.

4.0 WETLAND RESOURCE AREA IMPACTS

The proposed work within jurisdictional resource areas includes areas the FEMA Flood Zone AE. Table 2 provides a summary of the resource area impacted by the Project. The total Land Subject to Coastal Storm Flowage within the limit of work is approximately 189,990 square feet.

Table 2. Disturbances to Jurisdictional Wetland Resource Areas within Zone AE (in square feet)

Resource Area	Existing Impervious (within limit of work)	Proposed Impervious (within limit of work)
Land Subject to Coastal Storm Flowage (Zone AE)	186,830	147,430

5.0 PROPOSED MITIGATION MEASURES

The proposed project includes numerous mitigation measures to reduce the impact of the project on adjacent environmentally-sensitive areas.

5.1 Construction Period Erosion and Sedimentation Controls

Erosion and sedimentation controls are proposed to reduce the construction-related impact of the proposed project on adjacent wetland resource areas. Control measures will include, but are not limited to, minimizing land disturbance, providing temporary stabilization and covers, installing perimeter controls (silt fence and straw wattles/bales), constructing temporary sediment basins, and providing stormwater inlet protection (silt sack, straw wattles/bales). The contractor will be required to do inspections of all controls regularly to ensure that the controls are working properly. The contractor shall clean and reinstall any control that needs to be cleaned or replaced. Additionally, the contractor will clean/flush the entire stormwater management system prior to final acceptance by the owner.

The proposed project will disturb more than one acre of land, which requires the filing of a National Pollutant Discharge Elimination System (NPDES) Stormwater Construction General Permit. To apply for coverage under this General Permit, a Notice of Intent will be submitted to the U.S.

Environmental Protection Agency prior to the commencement of construction by the Contractor. The NPDES Notice of Intent requires the development and implementation of a Stormwater Pollution Prevention Plan (SWPPP) for construction activities, which will be submitted to the Conservation Commission and the DEP prior to construction by the Contractor. The SWPPP is a detailed erosion and sediment control plan that indicates the structural and non-structural erosion and sediment controls that will be employed, as appropriate, to control erosion on the construction site. A draft of the SWPPP is included in the Stormwater Report (Attachment D).

5.2 Post-Construction Stormwater Management

The proposed stormwater management system is designed in accordance with the MassDEP Stormwater Management Standards. Best Management Practices (BMPs) will be used to mitigate potential changes in runoff, promote infiltration, and provide water quality treatment.

Water quality treatment and mitigation is provided per the MassDEP Stormwater Standards. See the attached Stormwater Report for additional details.

The Stormwater Report includes an Operation and Maintenance Plan that was prepared in compliance with Standard 9 of the 2008 MassDEP Stormwater Handbook to provide best management practices for implementing maintenance activities for the stormwater management system in a manner that minimizes impacts to wetland resource areas.

5.3 Long-Term Pollution Prevention

A Long-Term Pollution Prevention Plan has been prepared in compliance with the Standards 4 and 9 of the 2008 Massachusetts Department of Environmental Protection (MassDEP) Stormwater Handbook, see the Long-Term Pollution Prevention Plan in the Stormwater Report for additional details.

6.0 CONCLUSION

On behalf of the Applicant, Nitsch Engineering is filing the enclosed Notice of Intent (NOI) Application with the Boston Conservation Commission for the construction of the new 2 Harbor Street site. The project will require some alteration of Resource Areas (Land Subject to Coastal Storm Flowage) under the Massachusetts Wetlands Protection Act (M.G.L. c. 131, §40) and its Regulations (310 CMR 10.00). The Project provides numerous mitigation measures including: reducing the amount of impervious areas onsite and improving the stormwater management system to meet the MassDEP Stormwater Management Standards. This NOI report and supporting documentation provide a thorough description of the design details and regulatory compliance in accordance with the pertinent Wetland Statutes and Regulations. The Applicant seeks an Order of Conditions approving the Project as proposed.

2 Harbor Street Statement on Climate Resiliency

The proposed project improvements consider climate change in multiple ways including sea level rise, heat island effect and plantings, and stormwater runoff impacts.

Sea Level Rise

The Boston Planning and Development Agency has determined a Sea Level Rise Base Flood Elevation (SLR-BFE) of 19.5 ft (BCB) for the 2 Harbor Street parcel which is above the FEMA flood elevation of 16.46 BCB. The proposed building's use requires 1-foot of freeboard above SLR-BFE for the design flood elevation which would be 20.50 BCB for this site. The building's proposed first floor elevation is 20.75 Boston City Base (BCB) which is above the current FEMA flood elevation and the SLR-BFE. The building's main electrical room and transformer vault as well as air handling and condensing units are located above elevation 20.50 BCB.

Heat Island Effect and Plantings

The existing site is 98 percent impervious, with 36 percent of the site covered by roof area and 62 percent covered by asphalt pavement. Vegetative cover will increase in the proposed condition from 2 percent of the site to 15 percent of the site. Following the USGBC criteria for non-roof, urban heat island reduction, this project is proposing three measures:

- Installation of plants that provide shade over paving areas on the site within 10 years of planting and vegetated planters. Plants will be in place at the time of occupancy permit and do not include artificial turf.
- Providing shade with two overhead trellis structures that have a three-year aged solar reflectance (SR) value of at least 0.28. If three-year aged value information is not available, use materials with an initial SR of at least 0.33 at installation.
- Use of paving materials with a three-year aged solar reflectance (SR) value of at least 0.28.

Across the site, measures have been taken to use either paving materials with solar reflectance (SR) values as defined by the USGBC and use canopy trees to shade much of the site. The primary axis to the building's front door from the Haul Road/Northern Avenue corner is lined with an overhead shade canopy and line of fastigate trees to provide shade on the promenade under the canopy as well as to partially shade the main plaza space. To the north of the plaza space a lawn with turf grass will allow outdoor seating, and a raised landform with a grove of canopy trees shade the paths and seating areas immediately adjacent to that landform. The southern portion of the of the site is proposed to be a series of canopy trees planted closely to achieve a full canopy "ceiling" of vegetation, enclosing a number of occupiable spaces.

To the south of the building the proposed surface parking is proposed with robust parking islands and tree planting to mitigate heat island effect on this portion of the site. To the east, the streetscape all along Harbor Street takes advantage of the condition where parking is not allowed thereby eliminating the need for pedestrian passage between the curb and sidewalk. This landscape zone will be heavily planted with native street trees and a vegetated landscape zone in lieu of permeable pavement.

Stormwater Runoff Impacts

As climate change progresses, storm events will intensify, and the possibility of flooding will increase. The proposed site provides stormwater mitigation measures including storage tanks and underground infiltration systems. The tank and chambers provide storage volume and allow stormwater to infiltrate into the ground instead of discharging to the storm sewers. The proposed best management practices in addition to the reduction in impervious area will decrease the peak stormwater runoff rates and volumes from the site.

Stormwater runoff from paved surfaces has the potential to be hot and damaging to the receiving waters. The proposed infiltration practices are sized to detain the first 1.25-inch of runoff from the impervious areas of the site which will allow water to cool and infiltrate instead of being discharged directly into the Harbor. The reduction in paved and impervious surfaces will also help with the temperature of the stormwater runoff from the site.

Alternatives Analysis

Alternative 1: No Build

Description: The existing building is to remain and no site improvements are proposed.

1. *Protection of public or private water supply and quality*
The existing site provides no stormwater quality treatment and would be considered a Land Use with Higher Potential Pollutant Loading were it to be constructed today. There is limited protection of the Boston Harbor in the no build condition because untreated stormwater runoff is discharged.
2. *Protection of the public and private groundwater supply and quality*
The majority of the “No Build” site is impervious area that does not allow for any infiltration.
3. *Short term and long term coastal and stormwater flood control*
The “no build” site does not have any stormwater runoff best management practices. There is no mitigation before it is discharged into the harbor.
4. *Erosion and Sedimentation Control*
The no build condition contains loose sediment and debris onsite that could be washed offsite and into the City drainage system. The pavement is in poor condition and could cause additional sedimentation into the City drainage system and eventually the Harbor.
5. *Storm damage prevention, including coastal storm flowage*
There are no mitigation measures in place to prevent storm damage in minor storm events or storm events where coastal storm flowage impacts the site. There are no best management practices onsite to capture and mitigate stormwater runoff and there are no protections for the existing building from coastal storm flowage.
6. *Protection of surface water supply and quality, including water pollution control*
The existing site provides no stormwater quality treatment and would be considered a Land Use with Higher Potential Pollutant Loading were it to be constructed today. There is limited protection of the Boston Harbor in the no build condition because untreated stormwater runoff is discharged.
7. *Flood conveyance and storage*
There are no existing systems in place for flood conveyance or storage.

8. *Protection of fisheries, land containing shellfish, wildlife habitat, rare and endangered species and habitat, wetland plant habitat, and recreation*

There are no existing best management practices on the site to treat stormwater runoff or to improve the temperature of stormwater runoff from hot asphalt areas.

9. *Protect the health, safety, and welfare of the public and to mitigate impacts of climate change.*

The “no build” condition contains a deteriorating building that poses a hazard to the public. There is no existing stormwater management system and untreated and unmitigated stormwater runoff is discharged directly into the harbor.

Alternative 2 (Preferred Alternative): Full Build as Proposed in the NOI

Description: The building, parking lot, landscaped areas, and stormwater management system are built as shown on the Civil Site Plans and Stormwater Report submitted as part of the NOI package.

1. *Protection of public or private water supply and quality*

The proposed project will contain a stormwater management system that properly treats stormwater runoff prior to it being discharged into the Boston Harbor. The Massachusetts DEP stormwater Treatment Standards will be met by the new project. In addition, there will be a lower level of pollutant loading from the site because the land use will no longer be a Land Use with Higher Potential Pollutant Loading and there will be a decrease in vehicular pavement onsite.

2. *Protection of the public and private groundwater supply and quality*

The proposed project will include infiltration systems that are sized to infiltrate 1.25 inches of runoff from the impervious areas onsite. The stormwater runoff will receive pretreatment prior to being discharged into the infiltration systems per the Massachusetts DEP Stormwater Handbook.

3. *Short term and long term coastal and stormwater flood control.*

The proposed project includes the construction of stormwater storage tanks and infiltration systems. The systems in addition to the reduction in impervious area onsite will decrease the peak runoff rates and runoff volumes from the site.

4. *Erosion and Sedimentation Control*

The project will have erosion and sedimentation control measures in place throughout construction and will meet the EPA Construction General Permit requirements. The site will be required to follow a Long Term Pollution Prevention Plan after construction is completed. The site will be fully stabilized prior to the erosion and sedimentation control measures being removed.

5. *Storm damage prevention, including coastal storm flowage*

The proposed project includes the construction of stormwater storage tanks and infiltration systems. The systems in addition to the reduction in impervious area onsite will decrease the peak runoff rates and runoff volumes from the site.

6. *Protection of surface water supply and quality, including water pollution control*

The proposed project will contain a stormwater management system that properly treats stormwater runoff prior to it being discharged into the Boston Harbor. The Massachusetts DEP stormwater Treatment Standards will be met by the new project. In addition, there will be a lower level of pollutant loading from the site because the land use will no longer be a Land Use

with Higher Potential Pollutant Loading and there will be a decrease in vehicular pavement onsite.

7. *Flood conveyance and storage*

There is no additional flood storage volume proposed onsite, however there is stormwater management storage provided onsite. The proposed building is designed to allow for coastal storm flowage by having a finished floor elevation above the flood elevation.

8. *Protection of fisheries, land containing shellfish, wildlife habitat, rare and endangered species and habitat, wetland plant habitat, and recreation*

The proposed project will contain a stormwater management system that properly treats stormwater runoff prior to it being discharged into the Boston Harbor.

Stormwater runoff from paved surfaces has the potential to be hot and damaging to the receiving waters. The proposed infiltration practices are sized to detain the first 1.25-inch of runoff from the impervious areas of the site which will allow water to cool and infiltrate instead of being discharged directly into the Harbor. The reduction in paved and impervious surfaces will also help with the temperature of the stormwater runoff from the site.

9. *Protect the health, safety, and welfare of the public and to mitigate impacts of climate change.*

In addition to the construction of a stormwater management system and raising the first floor elevation of the building above the flood plain, the project will promote public welfare by mitigating the heat island effects from the site and providing shade trees.

Alternative 3: Building with Additional Parking

Description: The building and parking lot are constructed as shown on the proposed Civil Site Plans submitted as part of the NOI. An additional 35 space surface parking lot is constructed to the northwest of the proposed building along Massport Haul Road instead of the plaza/landscaped area shown on the Civil Site Plans. This option results in an increase in pervious area from the “No Build” condition but a decrease in pervious area from the “Alternative 2.” This option results in an increase in vehicular impervious area from “Alternative 2.” The attached figures “Previously Proposed Site Plan,” show this alternative.

1. *Protection of public or private water supply and quality*

The proposed project will contain a stormwater management system that properly treats stormwater runoff prior to it being discharged into the Boston Harbor. The Massachusetts DEP stormwater Treatment Standards will be met by the new project. In addition, there would be a lower level of pollutant loading from the site because the land use will no longer be a Land Use with Higher Potential Pollutant Loading and there will be a decrease in vehicular pavement onsite from the No Build Condition. There will be more vehicular pavement onsite compared to the Alternative 2.

2. *Protection of the public and private groundwater supply and quality*

The proposed project will include infiltration systems that are sized to infiltrate 1.25 inches of runoff from the impervious areas onsite. The stormwater runoff will receive pretreatment prior to being discharged into the infiltration systems per the Massachusetts DEP Stormwater Handbook.

3. *Short term and long term coastal and stormwater flood control.*

The proposed project includes the construction of stormwater storage tanks and infiltration systems. The systems in addition to the reduction in impervious area onsite will decrease the

peak runoff rates and runoff volumes from the site. There is less of a reduction in impervious area in this scenario compared to Alternative 2.

4. *Erosion and Sedimentation Control*

The project will have erosion and sedimentation control measures in place throughout construction and will meet the EPA Construction General Permit requirements. The site will be required to follow a Long Term Pollution Prevention Plan after construction is completed. The site will be fully stabilized prior to the erosion and sedimentation control measures being removed.

5. *Storm damage prevention, including coastal storm flowage*

The proposed project includes the construction of stormwater storage tanks and infiltration systems. The systems in addition to the reduction in impervious area onsite will decrease the peak runoff rates and runoff volumes from the site. There is less of a reduction in impervious area in this scenario compared to Alternative 2.

6. *Protection of surface water supply and quality, including water pollution control*

The proposed project will contain a stormwater management system that properly treats stormwater runoff prior to it being discharged into the Boston Harbor. The Massachusetts DEP stormwater Treatment Standards will be met by the new project. In addition, there will be a lower level of pollutant loading from the site because the land use will no longer be a Land Use with Higher Potential Pollutant Loading and there will be a decrease in vehicular pavement onsite. There is less of a reduction in vehicular impervious area in this scenario compared to Alternative 2.

7. *Flood conveyance and storage*

There is no additional flood storage volume proposed onsite, however there is stormwater management storage provided onsite. The proposed building is designed to allow for coastal storm flowage by having a finished floor elevation above the flood elevation.

8. *Protection of fisheries, land containing shellfish, wildlife habitat, rare and endangered species and habitat, wetland plant habitat, and recreation*

The proposed project will contain a stormwater management system that properly treats stormwater runoff prior to it being discharged into the Boston Harbor. Stormwater runoff from paved surfaces has the potential to be hot and damaging to the receiving waters. The proposed infiltration practices are sized to detain the first 1.25-inch of runoff from the impervious areas of the site which will allow water to cool and infiltrate instead of being discharged directly into the Harbor. The reduction in paved and impervious surfaces will also help with the temperature of the stormwater runoff from the site. There is less of a reduction in impervious area in this scenario compared to Alternative 2.

9. *Protect the health, safety, and welfare of the public and to mitigate impacts of climate change*

In addition to the construction of a stormwater management system and raising the first floor elevation of the building above the flood plain, the project will promote public welfare by mitigating the heat island effects from the site and providing shade trees. In this alternative, there will be less of a reduction in heat island effect and fewer shade trees provided because there will be more vehicular pavement instead of plaza and landscaped areas.

ALTERNATIVE 2



VIEW ABOVE HAUL RD (PHASE I) III. BUILDING DESIGN

ALL FIGURES AND ILLUSTRATIONS APPROXIMATE

HANDEL ARCHITECTS / STUDIO ENÉE / KMDG / TRIA DESIGN / COSENTINI FOR BEACON CAPITAL PARTNERS

2 HARBOR STREET | 27 APRIL 2021 | PAGE 38

ALTERNATIVE 3



PREVIOUSLY PROPOSED VIEW ABOVE NORTHERN AVE @ HAUL RD II. WHERE WE WERE

ALTERNATIVE 3



PREVIOUSLY PROPOSED SITE PLAN II. WHERE WE WERE

SECTION 3

DOCUMENTATION OF ABUTTER NOTIFICATION

Abutter Notification (English)
Abutter Notification (Chinese)
Babel Notice
Affidavit of Service
Certified Abutters List

NOTIFICATION TO ABUTTERS UNDER THE MASSACHUSETTS WETLANDS PROTECTION ACT

In accordance with the Massachusetts Wetlands Protection Act, Massachusetts General Laws Chapter 131, Section 40, and the Boston Wetlands Ordinance, you are hereby notified as an abutter to a project filed with the Boston Conservation Commission.

- A. Beacon Capital Partners has filed a Notice of Intent with the Boston Conservation Commission seeking permission to alter an Area Subject to Protection under the Wetlands Protection Act (General Laws Chapter 131, section 40) and Boston Wetlands Ordinance.
- B. The address of the lot where the activity is proposed is 2 Harbor Street.
- C. The project involves the construction of a new office and laboratory building along with associated site improvements including the construction of a new parking lot, the relocation of existing utilities, the construction of new building utility services, and the construction of a new stormwater management system.
- D. Copies of the Notice of Intent may be obtained by contacting the Boston Conservation Commission at CC@boston.gov.
- E. Copies of the Notice of Intent may be obtained from Chris Hodney, chodney@nitscheng.com, at Nitsch Engineering, Inc, between the hours of 9 AM to 5 PM, Monday through Friday.
- F. In accordance with the Commonwealth of Massachusetts Executive Order Suspending Certain Provisions of the Open Meeting Law, the public hearing will take place **virtually** at <https://zoom.us/j/6864582044>. If you are unable to access the internet, you can call 1-929-205-6099, enter Meeting ID 686 458 2044 # and use # as your participant ID.
- G. Information regarding the date and time of the public hearing may be obtained from the **Boston Conservation Commission** by emailing CC@boston.gov or calling **(617) 635-3850** between the hours of **9 AM to 5 PM, Monday through Friday**.

NOTE: Notice of the public hearing, including its date, time, and place, will be published at least five (5) days in advance in the Boston Herald.

NOTE: Notice of the public hearing, including its date, time, and place, will be posted on www.boston.gov/public-notices and in Boston City Hall not less than forty-eight (48) hours in advance.

NOTE: If you would like to provide comments, you may attend the public hearing or send written comments to CC@boston.gov or Boston City Hall, Environment Department, Room 709, 1 City Hall Square, Boston, MA 02201.

NOTE: You also may contact the Boston Conservation Commission or the Department of Environmental Protection Northeast Regional Office for more information about this application or the Wetlands Protection Act. To contact DEP, call: the Northeast Region: (978) 694-3200.



BABEL NOTICE

English:

IMPORTANT! This document or application contains **important information** about your rights, responsibilities and/or benefits. It is crucial that you understand the information in this document and/or application, and we will provide the information in your preferred language at no cost to you. If you need them, please contact us at cc@boston.gov or 617-635-3850.

Spanish:

¡IMPORTANTE! Este documento o solicitud contiene **información importante** sobre sus derechos, responsabilidades y/o beneficios. Es fundamental que usted entienda la información contenida en este documento y/o solicitud, y le proporcionaremos la información en su idioma preferido sin costo alguno para usted. Si los necesita, póngase en contacto con nosotros en el correo electrónico cc@boston.gov o llamando al 617-635-3850.

Haitian Creole:

AVI ENPÒTAN! Dokiman oubyen aplikasyon sa genyen **enfòmasyon ki enpòtan** konsènan dwa, responsablite, ak/oswa benefis ou yo. Li enpòtan ke ou konprann enfòmasyon ki nan dokiman ak/oubyen aplikasyon sa, e n ap bay enfòmasyon an nan lang ou prefere a, san ou pa peye anyen. Si w bezwen yo, tanpri kontakte nou nan cc@boston.gov oswa 617-635-3850.

Traditional Chinese:

非常重要！這份文件或是申請表格包含關於您的權利，責任，和／或福利的重要信息。請您務必完全理解這份文件或申請表格的全部信息，這對我們來說十分重要。我們會免費給您提供翻譯服務。如果您有需要請聯系我們的郵箱 cc@boston.gov 電話# 617-635-3850..

Vietnamese:

QUAN TRỌNG! Tài liệu hoặc đơn yêu cầu này chứa **thông tin quan trọng** về các quyền, trách nhiệm và/hoặc lợi ích của bạn. Việc bạn hiểu rõ thông tin trong tài liệu và/hoặc đơn yêu cầu này rất quan trọng, và chúng tôi sẽ cung cấp thông tin bằng ngôn ngữ bạn muốn mà không tính phí. Nếu quý vị cần những dịch vụ này, vui lòng liên lạc với chúng tôi theo địa chỉ cc@boston.gov hoặc số điện thoại 617-635-3850.

Simplified Chinese:

非常重要！这份文件或是申请表格包含关于您的权利，责任，和／或福利的重要信息。请您务必完全理解这份文件或申请表格的全部信息，这对我们来说十分重要。我们会免费给您提供翻译服务。如果您有需要请联联系我们的邮箱 cc@boston.gov 电话# 617-635-3850.

Cape Verdean Creole:

INPURTANTI! Es dukumentu ó aplikason ten **informason inpur tanti** sobri bu direitus, rasponsabilidadi i/ó benefisius. Ê krusial ki bu intendi informason na es dukumentu i/ó aplikason ó nu ta da informason na língua di bu preferênsia sen ninhun kustu pa bó. Si bu prisiza del, kontata-nu na cc@boston.gov ó 617-635-3850.

Arabic:

مهم! يحتوي هذا المستند أو التطبيق على معلومات مهمة حول حقوقك ومسؤولياتك أو فوائدك. من الأهمية أن تفهم المعلومات الواردة في هذا المستند أو التطبيق. سوف نقدم المعلومات بلغتك المفضلة دون أي تكلفة عليك. إذا كنت في حاجة إليها، يرجى الاتصال بنا على cc@boston.gov أو 617-635-3850.

Russian:

ВАЖНО! В этом документе или заявлении содержится **важная информация** о ваших правах, обязанностях и/или льготах. Для нас очень важно, чтобы вы понимали приведенную в этом документе и/или заявлении информацию, и мы готовы бесплатно предоставить вам информацию на предпочитаемом вами языке. Если Вам они нужны, просьба связаться с нами по адресу электронной почты cc@boston.gov, либо по телефону 617-635-3850.

Portuguese:

IMPORTANTE! Este documento ou aplicativo contém **Informações importantes** sobre os seus direitos, responsabilidades e/ou benefícios. É importante que você compreenda as informações contidas neste documento e/ou aplicativo, e nós iremos fornecer as informações em seu idioma de preferência sem nenhum custo para você. Se precisar deles, fale conosco: cc@boston.gov ou 617-635-3850.

French:

IMPORTANT ! Ce document ou cette demande contient des **informations importantes** concernant vos droits, responsabilités et/ou avantages. Il est essentiel que vous compreniez les informations contenues dans ce document et/ou cette demande, que nous pouvons vous communiquer gratuitement dans la langue de votre choix. Si vous en avez besoin, veuillez nous contacter à cc@boston.gov ou au 617-635-3850.





波士顿湿地保护委员会 项目邻近住户通知

根据《马萨诸塞州湿地保护法》、《马萨诸塞州普通法》第 131 章第 40 节以及《波士顿湿地条例》的规定，我们特此向您，即向波士顿湿地保护委员会提出申请的项目的邻近住户，发出以下通知。

- A. **Beacon Capital Partners** 已向波士顿湿地保护委员会提出申请，请求批准改建一块受《湿地保护法》（《普通法》第 131 章第 40 节）和《波士顿湿地条例》保护的地块。
- B. 拟开展改建活动的地块地址为：2 Harbor Street.
- C. 该项目涉及以下建设内容：该项目涉及建设一个新办公室及实验室大楼以及相关地盘修缮工程，包括建设一个新停车场、搬遷現有公共設施、建設新大樓公共設施服務以及建設新雨水管理系統。
- D. 可通過聯繫波士頓保護委員會取得意向通知書的副本，電子郵件是 CC@boston.gov。
- E. 您可于 意向通知副本可於星期一至星期五上午9時至下午5時向Nitsch Engineering, Inc的Chris Hodney (chodney@nitscheng.com) 索取处获取意向通知的副本。
- F. 根據《馬薩諸塞州行政命令》（暫緩執行《公開會議法》聽證會將在網上 <https://zoom.us/j/6864582044> 進行。如果無法上互聯網 (Internet)，則可致電 1-929-205-6099，輸入會議編號(ID) 686 458 2044 #，然後使用 # 作為您參與的編號 (ID.)
- G. 您可于 周一至周五上午 9 点到下午 5 点联系波士顿湿地保护委员会，咨询公开听证会举行的日期和时间，邮箱地址：CC@boston.gov，电话：(617) 635-4416。

注：公开听证会的通知（包括其举行日期、时间和地点）将提前至少五天在《波士顿先驱报》上予以公布。

注：公开听证会的通知（包括其举行日期、时间和地点）将提前至少四十八（48）小时发布在以下网页之上以及波士顿市政厅内：www.boston.gov/public-notice。如果您想提出意见或建议，您可以参加该公开听证会或将书面形式的意见或建议发送至 CC@boston.gov 或邮寄至以下地址：Boston City Hall, Environment Department, Room 709, 1 City Hall Square, Boston, MA 02201。

注：您也可以联系波士顿湿地保护委员会或环境保护部东北地区办公室，咨询有关此项申请或《湿地保护法》的更多信息。如要联系环境保护部，请致电：东北地区：(978) 694-3200。

注：如果您准备参加该公开听证会并需要口译服务，则请在听证会举行前一天中午 12 点前通过以下电子邮箱地址告知工作人员：CC@boston.gov。



**AFFIDAVIT OF SERVICE
FOR ABUTTER NOTIFICATION**

**Under the Massachusetts Wetlands Protection Act
and Boston Wetlands Ordinance**

I, _____, hereby certify under pains and penalties of perjury that that at least one week prior to the public hearing, I gave notice to abutters in compliance with the second paragraph of Massachusetts General Laws Chapter 131, section 40, and the DEP Guide to Abutter Notification dated April 8, 1994, in connection with the following matter:

A _____ was filed under the Massachusetts Wetlands Protection Act and/or the Boston Wetlands Ordinance by _____ for _____ located at _____.

The Abutter Notification For, the list of abutters to whom it was given, and their addresses are attached to this Affidavit of Service.

Chris Hody
Name

4/16/2021
Date

PID	OWNER	ADDRESSEE	MLG_ADDRESS	MLG_CITYSTATE	MLG_ZIPCODE	LOC_ADDRESS	LOC_CITY	LOC_ZIPCODE
602674020	UNITED STATES OF AMERICA	UNITED STATES OF AMERICA	424 TRAPELO RD	WALTHAM MA	2452	660 SUMMER ST	BOSTON	2127
602674035	ECONOMIC DEVELOPMENT AND	ECONOMIC DEVELOPMENT AND	1 CITY HALL SQ 9TH FL	BOSTON MA	2201	300 NORTHERN AV	BOSTON	2210
602674045	ECONOMIC DEVELOPMENT AND	ECONOMIC DEVELOPMENT AND	1 CITY HALL SQ 9TH FL	BOSTON MA	2201	306 NORTHERN AV	BOSTON	2210
602674055	ECONOMIC DEVELOPMENT AND	ECONOMIC DEVELOPMENT AND	1 CITY HALL SQ 9TH FL	BOSTON MA	2201	306 NORTHERN AV	BOSTON	2210
602674110	ECONOMIC DEVELOPMENT AND	ECONOMIC DEVELOPMENT AND	1 CITY HALL SQ 9TH FL	BOSTON MA	2201	329 NORTHERN AV	BOSTON	2210
602674115	ECONOMIC DEVELOPMENT AND	ECONOMIC DEVELOPMENT AND	1 CITY HALL SQ 9TH FL	BOSTON MA	2201	2 HARBOR ST	BOSTON	2210
602674120	ECONOMIC DEVELOPMENT AND	ECONOMIC DEVELOPMENT AND	1 CITY HALL SQ 9TH FL	BOSTON MA	2210	1 HARBOR ST	BOSTON	2210
602674125	ECONOMIC DEVELOPMENT AND	ECONOMIC DEVELOPMENT AND	1 CITY HALL SQ 9TH FL	BOSTON MA	2201	12 DRYDOCK AV	BOSTON	2210
602674145	ECONOMIC DEVELOPMENT AND	ECONOMIC DEVELOPMENT AND	1 CITY HALL SQ 9TH FL	BOSTON MA	2201	7 CHANNEL ST	BOSTON	2210
602674150	ECONOMIC DEVELOPMENT AND	ECONOMIC DEVELOPMENT AND	1 CITY HALL SQ 9TH FL	BOSTON MA	2201	12 CHANNEL ST	BOSTON	2210
602674215	ECONOMIC DEVELOPMENT AND	ECONOMIC DEVELOPMENT AND	1 CITY HALL SQ 9TH FL	BOSTON MA	2201	290 -294 NORTHERN AV	BOSTON	2210
602674220	ECONOMIC DEVELOPMENT AND	ECONOMIC DEVELOPMENT AND	1 CITY HALL SQ 9TH FL	BOSTON MA	2201	0 HARBOR ST	BOSTON	2210
602674221	ECONOMIC DEVELOPMENT AND	ECONOMIC DEVELOPMENT AND	1 CITY HALL SQ 9TH FL	BOSTON MA	2201	0 HARBOR ST	BOSTON	2210
602674225	ECONOMIC DEVELOPMENT AND	ECONOMIC DEVELOPMENT AND	1 CITY HALL SQ 9TH FL	BOSTON MA	2201	306 R NORTHERN AV	BOSTON	2210
602678600	COMMONWEALTH OF MASS	COMMONWEALTH OF MASS	TRILLING WY	BOSTON MA	2210	TRILLING WY	BOSTON	2210
602681000	COMMONWEALTH OF MASS	COMMONWEALTH OF MASS	30 TRILLING WAY	BOSTON MA	2210	30 TRILLING WY	BOSTON	2210
602681002	PARCEL K RESIDENTIAL	PARCEL K RESIDENTIAL	5950 SHERRY LANE SUITE #320	DALLAS TX	75225	295 - 315 NORTHERN AV	BOSTON	2210
602681500	PARCEL K GARAGE	PARCEL K GARAGE	5950 SHERRY LANE SUITE #320	DALLAS TX	75225	295 - 315 NORTHERN AV	BOSTON	2210
602681300	HP BOSTON PARTNERS LLC	HP BOSTON PARTNERS LLC	1800 WAZEE STREET SUITE #200	DENVER CO	80202	295 - 315 NORTHERN AV	BOSTON	2210
602683000	COMM OF MASS PORT AUTH	COMM OF MASS PORT AUTH	325 NORTHERN AVE	BOSTON MA	2210	325 NORTHERN AV	BOSTON	2210

Date: April 16th, 2021

Certificate of Accurate Translation

Translated document: General Translation

Translation date: April 16th, 2021

Project #: 8083284

Source Language: English

Target Language: Traditional
Chinese (HK)

Blend, the largest professional translation agency online, hereby certifies and states the following, that the above mentioned document has been translated by a certified professional translator who has the background and the experience needed to perform the translation. We further certify that, to the best of our knowledge, the translated document is accurate translation of the original document and that it reflects the content, style and meaning of the original document.

This certificate relates to the accuracy of the translation only and not to the original content of the document. In accordance with our general terms and conditions, Blend is not liable and will not be held liable to any result of using the translation by the client or any other party.

Please find the translation attached.

Yours Sincerely,

Blend



FIGURES

Figure 1 – USGS Locus Map

Figure 2 – Aerial Locus Map

Figure 3 – Natural Heritage and Endangered Species Program Map

Figure 4 – FEMA Floodplain Map

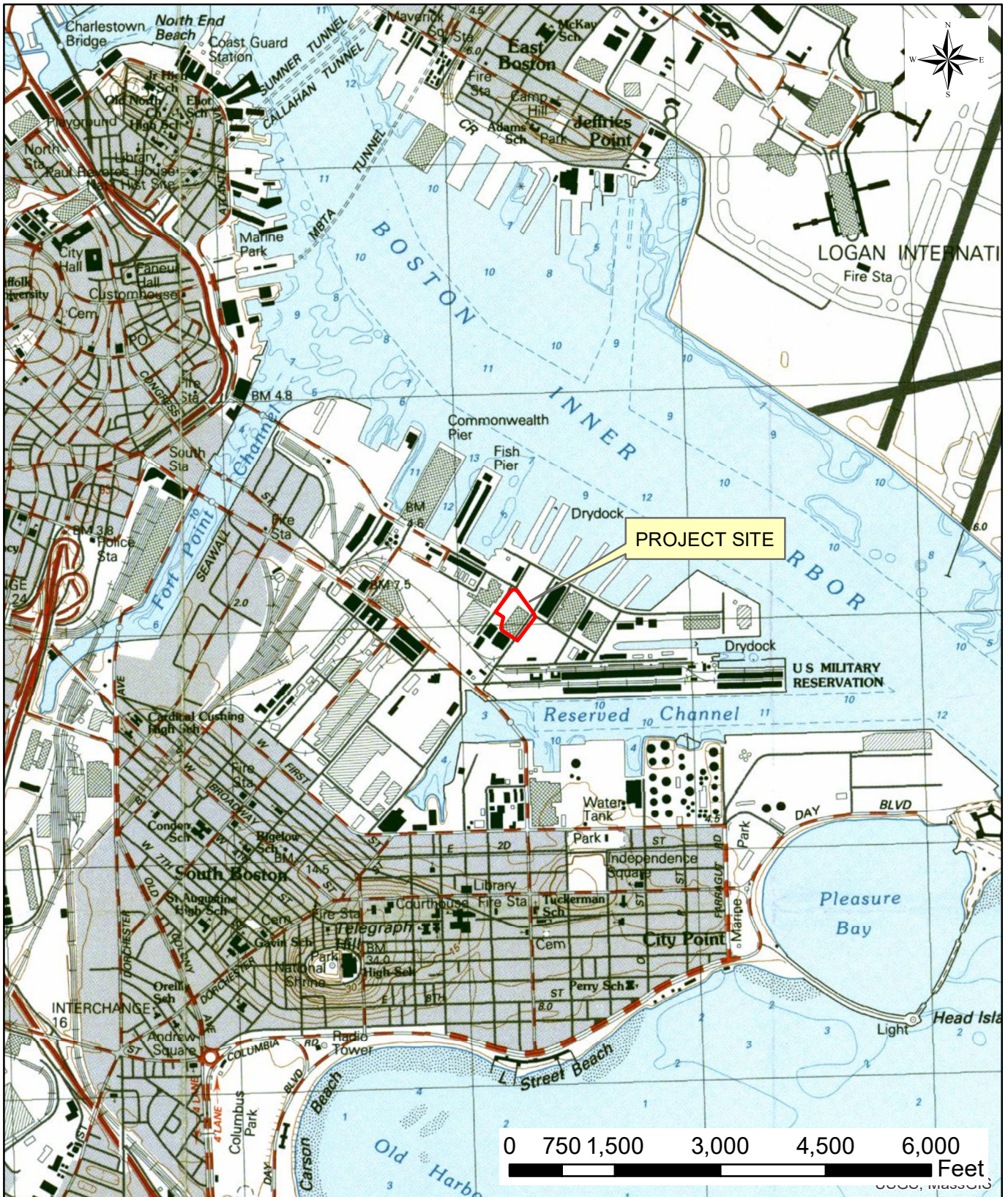

Figure 1: USGS Map
 2 Harbor Street
 Boston, MA 02210

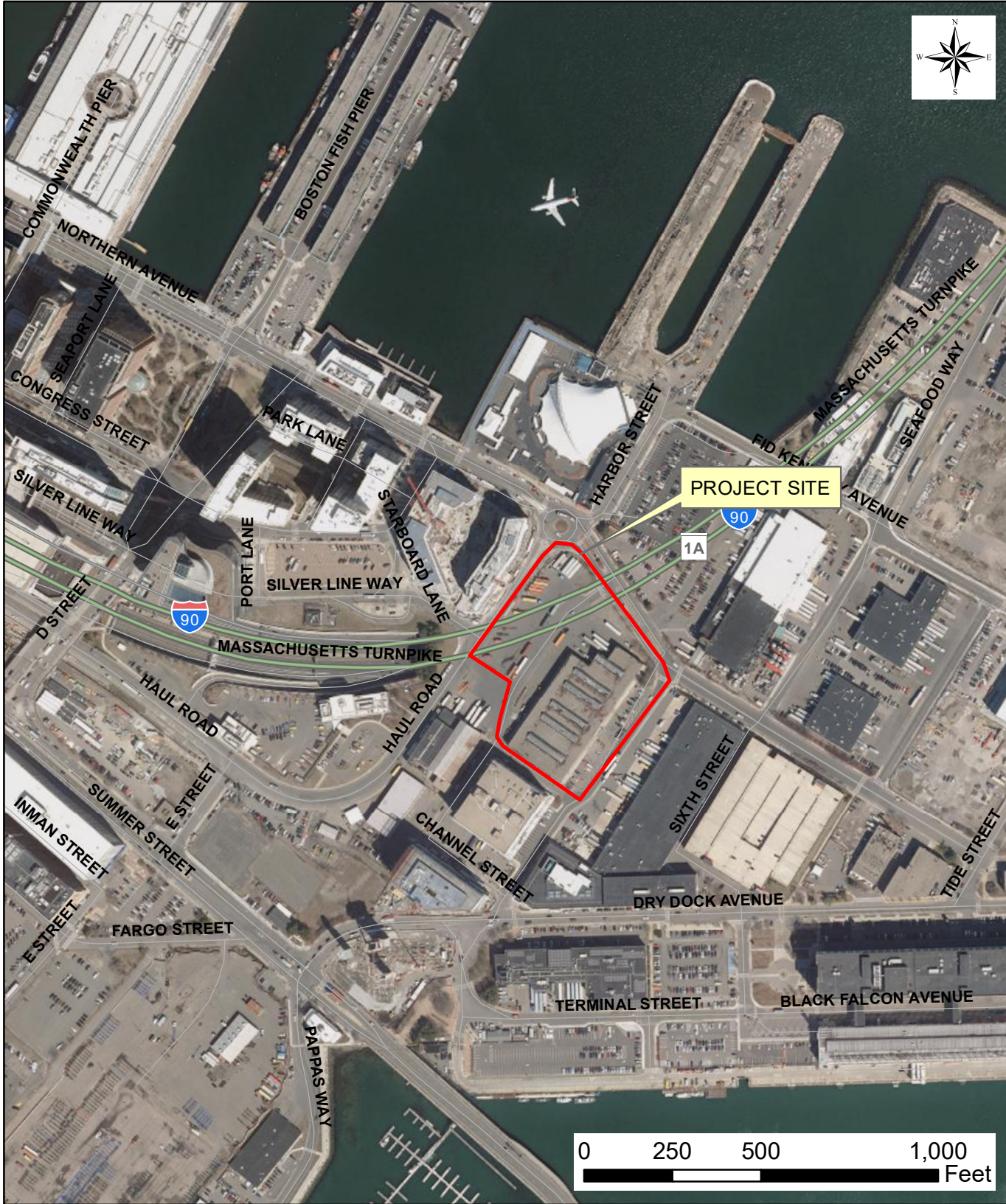

Figure 2: Aerial LOCUS Map
 2 Harbor Street
 Boston, MA 02210

Data Source: MassGIS
 Nitsch Project #13569



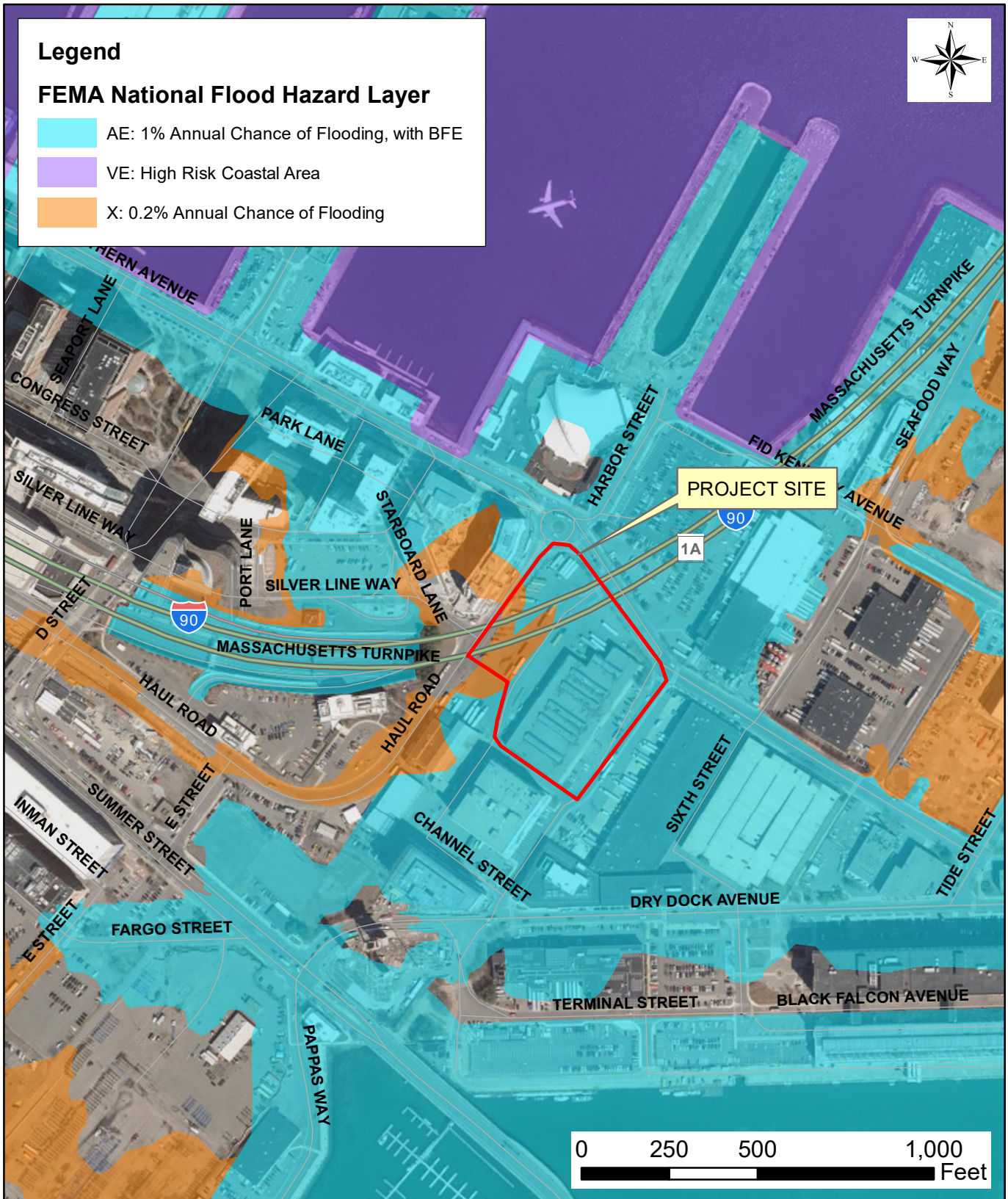

Figure 3: FEMA Flood Hazard Map
 2 Harbor Street
 Boston, MA 02210



Figure 4: NHESP Map
 2 Harbor Street
 Boston, MA 02210

NOTE: Project filings should be prepared and submitted using the online [Climate Resiliency Checklist](#).

A.1 - Project Information

Project Name:	2 Harbor		
Project Address:	2 Harbor Street, Boston, MA		
Project Address Additional:	329 Northern Avenue, Boston, MA		
Filing Type (select)			
Filing Contact	Kevin Donahoe	ICCNE LLC	Email 617-451-0300
Is MEPA approval required	Yes		Date

A.3 - Project Team

Owner / Developer:	ICCNE LLC
Architect:	Handel Architects LLP and Studio ENEÉ
Engineer:	Cosentini Associates
Sustainability / LEED:	VvS Architects & Consultants
Permitting:	Epsilon Associates
Construction Management:	TBD

A.3 - Project Description and Design Conditions

List the principal Building Uses:	Lab / Office / R&D
List the First Floor Uses:	Lab / Office / R&D / Supporting Uses
List any Critical Site Infrastructure and or Building Uses:	

Site and Building:

Site Area:	189,897 SF	Building Area:	380,800 SF
Building Height:	146 Ft	Building Height:	10 Stories
Existing Site Elevation – Low:	15.6 Ft BCB	Existing Site Elevation – High:	17.6 Ft BCB
Proposed Site Elevation – Low:	15.6 Ft BCB	Proposed Site Elevation – High:	20.5 Ft BCB
Proposed First Floor Elevation:	20.5 Ft BCB	Below grade levels:	1 Story

Article 37 Green Building:

LEED Version - Rating System:	4	LEED Certification:	Yes
Proposed LEED rating:	Gold	Proposed LEED point score:	61 Pts.

Building Envelope

When reporting R values, differentiate between R discontinuous and R continuous. For example, use "R13" to show R13 discontinuous and use R10c.i. to show R10 continuous. When reporting U value, report total assembly U value including supports and structural elements.

Roof:	R-35.7c.i.(R)	Exposed Floor:	R-26.3(R)
Foundation Wall:	R-7.5c.i.(R)	Slab Edge (at or below grade):	R-15(R)

Vertical Above-grade Assemblies (%'s are of total vertical area and together should total 100%):

Area of Opaque Curtain Wall & Spandrel Assembly:	37.3(%)	Wall & Spandrel Assembly Value:	U-0.06(U)
Area of Framed & Insulated / Standard Wall:	17.7(%)	Wall Value	R-30c.i.(R)
Area of Vision Window:	45%	Window Glazing Assembly Value:	U-0.32(U)
		Window Glazing SHGC:	0.31(SHGC)
Area of Doors:	TBD%	Door Assembly Value:	0.65(U)

Energy Loads and Performance

For this filing – describe how energy loads & performance were determined

	Via eQuest model		
Annual Electric:	9172137 (kWh)	Peak Electric:	9,500 (kW)
Annual Heating:	7908 (MMbtu/hr)	Peak Heating:	39,000 (MMbtu)
Annual Cooling:	(Tons/hr)	Peak Cooling:	3,400 (Tons)
Energy Use - Below ASHRAE 90.1 - 2013:	44.3%	Have the local utilities reviewed the building energy performance?:	Yes
Energy Use - Below Mass. Code:	44.3%	Energy Use Intensity:	80.9 (kBtu/SF)

Back-up / Emergency Power System

Electrical Generation Output:	2,000 (kW)	Number of Power Units:	1
System Type:	(kW)	Fuel Source:	

Emergency and Critical System Loads (in the event of a service interruption)

Electric:	TBD (kW)	Heating:	3,800 (MMbtu/hr)
		Cooling:	None (Tons/hr)

B – Greenhouse Gas Reduction and Net Zero / Net Positive Carbon Building Performance

Reducing GHG emissions is critical to avoiding more extreme climate change conditions. To achieve the City's goal of carbon neutrality by 2050 new buildings performance will need to progressively improve to net carbon zero and positive.

B.1 – GHG Emissions - Design Conditions

For this Filing - Annual Building GHG Emissions: 3,589 (Tons)

For this filing - describe how building energy performance has been integrated into project planning, design, and engineering and any supporting analysis or modeling:

Sustainability has been a part of the project since early phases. The sustainability consultant was engaged early in the project planning / concept phase. The client and design team participated in a sustainability kick off charrette during which various sustainability strategies, goals and certification options were discussed. Building energy performance has been evaluated and building energy modeling has been conducted to document a 30% reduction in GHG emissions from the baseline case of a code-compliant building.

Describe building specific passive energy efficiency measures including orientation, massing, envelop, and systems:

Key passive energy efficiency measures include the use of thermally broken curtain wall with a low allowable infiltration rate, and reduced vision glazing from the original design. Two primary curtain wall types have been developed and deployed site-responsively. The type predominant on the north, east, and west facades utilizes vertical and horizontal fins to reduce the amount of vision glazing, glare and solar heat gain. The type predominant on the south reduces the percentage of vision glazing to reduce heat gain from solar exposure throughout the day.

Describe building specific active energy efficiency measures including equipment, controls, fixtures, and systems:

High performance equipment includes use of variable air volume units for commercial spaces and water-cooled direct expansion (DX) units or heat pumps for back-of-house spaces. The building will have a full Energy Management and Control System (EMCS). An optimized glycol loop will provide exhaust air energy recovery. Reduced Lighting Power Density will be required for all tenants.

Describe building specific load reduction strategies including on-site renewable, clean, and energy storage systems:

The Project will include a 3,300 sf PV panel installation on the ninth floor, or an equivalent amount elsewhere on the roof as tenant fit-out is completed. Hybrid air-source heat pump electric water heaters will be used on core toilets, and efficient natural gas and electric systems will be used throughout.

Describe any area or district scale emission reduction strategies including renewable energy, central energy plants, distributed energy systems, and smart grid infrastructure:

As property owned by the Boston Economic Development & Industrial Corporation (EDIC) in the Raymond L. Flynn Marine Park (RLFMP), a key goal of the Project development is to provide a funding mechanism for future RLFMP infrastructure improvements. No renewable/central/distributed energy or smart grid infrastructure is available in the RLFMP currently.

Describe any energy efficiency assistance or support provided or to be provided to the project:

The Project team has identified MassSave natural gas performance incentives available to the Project and is continuing contact with utility and state DOER representatives to identify available energy efficiency assistance or support.

B.2 - GHG Reduction - Adaptation Strategies

Describe how the building and its systems will evolve to further reduce GHG emissions and achieve annual carbon net zero and net positive performance (e.g. added efficiency measures, renewable energy, energy storage, etc.) and the timeline for meeting that goal (by 2050):

The PV array and the electrification of the core toilet heating systems support efforts to decarbonize the electric grid, and to use that electric grid to support future GHG reductions.

C - Extreme Heat Events

Annual average temperature in Boston increased by about 2 °F in the past hundred years and will continue to rise due to climate change. By the end of the century, the average annual temperature could be 56° (compared to 46° now) and the number of days above 90° (currently about 10 a year) could rise to 90.

C.1 - Extreme Heat - Design Conditions

Temperature Range - Low:	7 Deg.	Temperature Range - High:	91 Deg.
Annual Heating Degree Days:	5621	Annual Cooling Degree Days	2938

What Extreme Heat Event characteristics will be / have been used for project planning

Days - Above 90°:	60	Days - Above 100°:	30
Number of Heatwaves / Year:	6	Average Duration of Heatwave (Days):	5

Describe all building and site measures to reduce heat-island effect at the site and in the surrounding area:

The project will feature underground parking. The roof will meet characteristics of a cool roof, amenity decks will be light colored. The pavement around the project will be light-colored with SRI>33. Wherever possible on the site, the project will plant native landscaping

C.2 - Extreme Heat - Adaptation Strategies

Describe how the building and its systems will be adapted to efficiently manage future higher average temperatures, higher extreme temperatures, additional annual heatwaves, and longer heatwaves:

The project will feature underground parking. The roof will meet characteristics of a cool roof. The pavement around the project will be light-colored with SRI>33. Wherever possible on the site, the project will plant native landscaping. Improved envelope will reduce cooling loads during heatwaves.

Describe all mechanical and non-mechanical strategies that will support building functionality and use during extended interruptions of utility services and infrastructure including proposed and future adaptations:

The project will be energy efficient, will feature an advanced envelope and incorporate reduced Lighting Power Density to reduce cooling loads in the summer.

D - Extreme Precipitation Events

From 1958 to 2010, there was a 70 percent increase in the amount of precipitation that fell on the days with the heaviest precipitation. Currently, the 10-Year, 24-Hour Design Storm precipitation level is 5.25". There is a significant probability

that this will increase to at least 6” by the end of the century. Additionally, fewer, larger storms are likely to be accompanied by more frequent droughts.

D.1 – Extreme Precipitation - Design Conditions

10 Year, 24 Hour Design Storm:

Describe all building and site measures for reducing storm water run-off:

Stormwater infrastructure will meet the Boston Water and Sewer and BPDA requirements to retain the first 1.25 inch of stormwater onsite. An underground infiltration system or equivalent structure will be installed to infiltrate this volume into the ground. Permeable/porous pavement will be used in some site areas to further increase the site pervious area. The site is being greened, and will reduce the amount of impervious surface onsite, which will reduce the rate and volume of stormwater runoff.

D.2 - Extreme Precipitation - Adaptation Strategies

Describe how site and building systems will be adapted to efficiently accommodate future more significant rain events (e.g. rainwater harvesting, on-site storm water retention, bio swales, green roofs):

Storm water recharge (per above) and greening of the site through new landscaping and vegetation.

E – Sea Level Rise and Storms

Under any plausible greenhouse gas emissions scenario, sea levels in Boston will continue to rise throughout the century. This will increase the number of buildings in Boston susceptible to coastal flooding and the likely frequency of flooding for those already in the floodplain.

Is any portion of the site in a FEMA SFHA? What Zone:
Current FEMA SFHA Zone Base Flood Elevation:

Is any portion of the site in a BPDA Sea Level Rise - Flood Hazard Area? Use the online [BPDA SLR-FHA Mapping Tool](#) to assess the susceptibility of the project site.

If you answered YES to either of the above questions, please complete the following questions. Otherwise you have completed the questionnaire; thank you!

E.1 – Sea Level Rise and Storms – Design Conditions

Proposed projects should identify immediate and future adaptation strategies for managing the flooding scenario represented on the BPDA Sea Level Rise - Flood Hazard Area (SLR-FHA) map, which depicts a modeled 1% annual chance coastal flood event with 40 inches of sea level rise (SLR). Use the online [BPDA SLR-FHA Mapping Tool](#) to identify the highest Sea Level Rise - Base Flood Elevation for the site. The Sea Level Rise - Design Flood Elevation is determined by adding either 24” of freeboard for critical facilities and infrastructure and any ground floor residential units OR 12” of freeboard for other buildings and uses.

Sea Level Rise - Base Flood Elevation:	19.5 Ft BCB	First Floor Elevation:	20.5 Ft BCB
Sea Level Rise - Design Flood Elevation:	20.5 Ft BCB	Accessible Route Elevation:	16.5-20.5 Ft BCB
Site Elevations at Building:	16.5-20.5 Ft BCB		

Describe site design strategies for adapting to sea level rise including building access during flood events, elevated site areas, hard and soft barriers, wave / velocity breaks, storm water systems, utility services, etc.:

Elevated plaza and building entry at SLR DFE of approximately 20.5' BCB, placing mechanical equipment above the flood elevation at approximately 21.5' BCB.

Describe how the proposed Building Design Flood Elevation will be achieved including dry / wet flood proofing, critical systems protection, utility service protection, temporary flood barriers, waste and drain water back flow prevention, etc.:

Ground floor elevation will be placed at SLR DFE of approximately 20.5' BCB, with critical equipment placed 1' higher at approximately 21.5' BCB. Entrances to below-grade garage, loading areas, lobby access from Northern Avenue are below SLR DFE and will therefore require additional protection such as temporary flood barriers with wet and/or dry floodproofing.

Describe how occupants might shelter in place during a flooding event including any emergency power, water, and waste water provisions and the expected availability of any such measures:

As lab and office with no residential component, the building is not anticipated to be occupied during severe flooding events; however, the building will be equipped with rooftop emergency generators to protect critical systems and processes.

Describe any strategies that would support rapid recovery after a weather event:

Permeable paving will be deployed over the site to help deal effectively with stormwater inundation. The combination of raised ground level, further raised critical systems, and floodproofing measures means that the building will be able to return to normal use quickly after a flooding event.

E.2 – Sea Level Rise and Storms – Adaptation Strategies

Describe future site design and or infrastructure adaptation strategies for responding to sea level rise including future elevating of site areas and access routes, barriers, wave / velocity breaks, storm water systems, utility services, etc.:

The project is being elevated 4' above current ground level to approximately 20.5' BCB, 1' above the site's SLR BFE. This can reasonably be expected to protect the site from 1% annual chance flood events through the 2070s.

Describe future building adaptation strategies for raising the Sea Level Rise Design Flood Elevation and further protecting critical systems, including permanent and temporary measures:

The level of dry floodproofing measures could be raised should it become necessary in the future.

A pdf and word version of the Climate Resiliency Checklist is provided for informational use and off-line preparation of a project submission. **NOTE: Project filings should be prepared and submitted using the online [Climate Resiliency Checklist](#).**

For questions or comments about this checklist or Climate Change best practices, please contact: John.Dalzell@boston.gov



Nitsch Engineering

April 16, 2021

**STORMWATER
REPORT**

For

2 HARBOR STREET
Boston, MA

Prepared for:

Handel Architects
69 Canal Street, 2nd Floor
Boston, MA 02114

Prepared by:

NITSCH ENGINEERING, INC.
2 Center Plaza, Suite 430
Boston, MA 02143

Nitsch Project #13569

TABLE OF CONTENTS

1.0 INTRODUCTION 1

2.0 EXISTING CONDITIONS 1

2.1 Existing Drainage Infrastructure 1

2.2 NRSC Soil Designations 1

2.3 Wetland Resource Areas 2

2.4 Total Maximum Daily Load (TMDL)..... 2

3.0 PROPOSED CONDITIONS 2

3.1 Project Description..... 2

3.2 Stormwater Management System 3

3.3 Stormwater Management During Construction..... 4

4.0 STORMWATER MANAGEMENT ANALYSIS 4

4.1 Methodology 4

4.2 HydroCAD Version 10.00..... 4

4.3 Existing and Proposed Hydrologic Conditions..... 5

4.4 Peak Flow Rates..... 5

5.0 MASSDEP STORMWATER MANAGEMENT STANDARDS 5

Standard 1: No New Untreated Discharges..... 5

Standard 2: Peak Rate Attenuation 6

Standard 3: Groundwater Recharge..... 6

Standard 4: Water Quality Treatment..... 6

Standard 5: Land Uses with Higher Potential Pollutant Loads..... 7

Standard 6: Critical Areas 7

Standard 7: Redevelopments..... 7

Standard 8: Construction Period Pollution Prevention and Sedimentation Control 7

Standard 9: Operation and Maintenance Plan..... 8

Standard 10: Prohibition of Illicit Discharges 8

6.0 CLOSED DRAINAGE SYSTEM DESIGN..... 8

7.0 CONCLUSION..... 8

FIGURES

- DR-1 Existing Watershed Areas
- DR-2 Proposed Watershed Areas

APPENDICES

- Appendix A Stormwater Management Standards Documentation**
 - MassDEP Checklist for Stormwater Report
 - Standard 3: 72-HR Drawdown Calculations
 - Standard 3: Mounding Analysis
 - Standard 4: TSS Removal Calculations
 - Standard 4: Proprietary Water Quality Structure Calculations
 - Standard 10: Illicit Discharge Compliance Statement
- Appendix B Existing Conditions – HydroCAD Calculations**
- Appendix C Proposed Conditions – HydroCAD Calculations**
- Appendix D Closed Drainage System Design**
- Appendix E Long-Term Pollution Prevention and Stormwater Operation and Maintenance Plan**
- Appendix F DRAFT Stormwater Pollution Prevention Plan (SWPPP)**
- Appendix G Soil Investigations**
 - NRCS Soil Maps and Descriptions
 - Compiled Test Pit Information
- Appendix H Porous Asphalt System Design Information**
 - UNH Design Criteria
 - Time of Concentration Documentation

1.0 INTRODUCTION

Nitsch Engineering has prepared this Stormwater Report to support the Notice of Intent application to Boston for the new 2 Harbor Street project. The Project site is located at 2 Harbor Street. The project consists of the construction of a new office and laboratory building with associated site improvements.

The site improvements include the following:

1. Construction of parking facilities and pedestrian walkways;
2. Realignment of Channel Street;
3. Construction of landscaped areas;
4. Installation of new utilities to support the proposed building; and
5. Construction of a new stormwater management system.

The proposed stormwater management system has been designed to comply with the requirements of the Boston Water and Sewer Commission (BWSC) and the Massachusetts Department of Environmental Protection (DEP) Stormwater Management Standards.

2.0 EXISTING CONDITIONS

The Site is located at 2 Harbor Street. The approximately 4.4-acre site is previously developed and contained an approximately 71,000 square-foot warehouse building. The building was demolished in March and April of 2021 under an Emergency Order from the Boston Fire Department after it was damaged during a storm and determined to be unsafe. The building was located on the south of the site along Harbor Street. Channel Street cuts through the site to the north of the existing building and connects to Northern Avenue to the north of the site. The area to north of Channel Street is used for vehicular storage. The Stormwater Report and calculations are based on the assumption that the existing condition of the site still contains the building.

The existing site is approximately 98% impervious with elevations ranging from approximately 16 BCB to 20.3 BCB.

2.1 Existing Drainage Infrastructure

Stormwater generated by the existing 2 Harbor Site is collected in catch basins and is piped via a closed drainage system to BWSC storm drain mains in Harbor Street and Northern Avenue or to a MassDOT storm drain main that crosses through the site. The storm drain mains discharge into the Boston Harbor. Runoff from the roof of the existing building is collected and piped to a closed drainage system and ultimately discharged to the Boston Harbor. The existing stormwater management system was constructed prior to the 2008 MassDEP Stormwater Management Standards and the Site provides minimal peak flow attenuation, water quality treatment, and groundwater recharge.

2.2 NRSC Soil Designations

The Soil Classification Summary (Table 1) outlines the Natural Resources Conservation Services (NRCS) designation of the soil series at the Site. All of the soils are classified as Urban Land, wet substratum, which does not have an associated hydrologic soil group (HSG) rating (refer to the NRCS Soil Maps and Descriptions in Appendix G). Nitsch Engineering has conservatively assumed an HSG C for the stormwater calculations for the site.

Table 1. NRCS Soil Classification Summary

Soil Unit	Soil Series	Hydrologic Soil Group
603	Urban Land with Wet Substratum	--

2.3 Wetland Resource Areas

The site is located within the Land Subject to Coastal Storm Flowage (state designation) and the Coastal Flood Resilience Zone (Boston designation). The FEMA Flood Zone AE has a 100-year flood elevation for the site of 16.46 Boston City Base (BCB).

2.4 Total Maximum Daily Load (TMDL)

The Site ultimately discharges into the Boston Harbor. There is no Total Maximum Daily Load (TMDL) prepared for the Boston Harbor although the harbor is classified as impaired. The impairments for the harbor include pathogens and PCBs. The Project has been designed to treat and infiltrate stormwater runoff which will reduce pathogen loading in the runoff from the site.

3.0 PROPOSED CONDITIONS

3.1 Project Description

The proposed Project includes the construction of an approximately 53,650 square foot office and laboratory building with associated site improvements. The proposed site improvements include the following:

1. Construction of parking facilities and pedestrian walkways;
2. Realignment of Channel Street;
3. Construction of landscaped areas;
4. Installation of new utilities to support the proposed building; and
5. Construction of a new stormwater management system.

The Project is anticipated to decrease the overall impervious area for the Project by approximately 25,310 square feet (0.6 acres) and is therefore considered a redevelopment. In addition, 14,090 square feet (0.3 acres) of the "impervious" area is porous pavers/pavement and will act as if it is pervious surface cover. Refer to Table 2 for a comparison of the existing and proposed land use for the Site.

Table 2. Proposed land use for 2 Harbor Street (in square feet)

Land Use	Existing (SF)	Proposed (SF)	Change
Buildings	70,800	53,650	-17,150
Site Impervious Area	116,030	93,780	-22,250
Permeable Pavers/Pavement	-	14,090	+14,090
Vegetation	3,160	28,470	+25,310
Total	189,990	189,990	---

3.2 Stormwater Management System

The Site will include the installation of a stormwater management system that is being designed to meet the MassDEP Stormwater Management Standards and BWSC requirements. As a redevelopment, the Project is required to meet the Stormwater Management Standards to the maximum extent practicable as described in Section 5.

The proposed stormwater management system for the Project will include porous asphalt/porous pavers, deep-sump and hooded catch basins, subsurface infiltration systems, and proprietary water quality structures. Overflow from the proposed BMPs will be discharged to the Boston Harbor through existing storm drain mains.

Deep Sump and Hooded Catch Basins

Deep-sump and hooded catch basins are proposed to provide pretreatment in the impervious areas of the parking lot and driveways. Stormwater captured in the catch basins will be directed to another treatment or infiltration BMP prior to discharge.

Porous Asphalt

Porous asphalt and paver systems, totaling approximately 0.3 acres, are proposed as part of this project. Porous asphalt is proposed for use in the parking stalls of the parking lot but the drive aisles will be standard asphalt. The standard asphalt drive aisles will not pitch towards the porous asphalt.

The porous asphalt will replace traditional impervious parking areas and allow runoff to be treated and infiltrated within the pavement section. The filter course and reservoir course were sized according to the University of New Hampshire Design Specifications for Porous Asphalt Pavement and Infiltration Beds. The porous asphalt will overflow to a stormwater storage tank which will then discharge to a subsurface infiltration system.

Subsurface Infiltration/Detention Systems

Stormwater Infiltration System 1 is to the south of Channel Street and west of the proposed building. Stormwater runoff from the parking lot and roof will be collected and directed into a 14,500 cubic foot tank underneath the building. The tank is sized to collect the 1.25-inch runoff from tributary site impervious areas per BWSC requirements. Stormwater runoff in excess of the 1.25-inch volume will overflow via gravity to a storm main and discharge into the Boston Harbor. The stormwater in the tank will be pumped to Infiltration System 1 at a rate that allows the system to fully infiltrate the 1.25-inch storm within 72 hours.

Subsurface Infiltration System 2 is to the north of Channel Street and collects stormwater runoff from pedestrian, landscape, and vehicular areas. Stormwater runoff will be collected in deep-sump and hooded catch basins and then be directed to a water quality structure. The water quality structure will discharge into a subsurface infiltration system made of 30-inch plastic arch chambers in crushed stone. The system is designed to store infiltrate the 1.25-inch runoff from tributary impervious areas per BWSC's requirement. Overflow from the Subsurface Infiltration System 2 will discharge into the Boston Harbor.

Water Quality Structures

Two proprietary water quality structures are proposed for water quality pretreatment in areas of the Site where space is limited or additional pretreatment is required prior to infiltration. These BMPs have been designed to remove greater than 80% TSS in conjunction with their associated deep-sump and hooded catch basins. Sizing calculations are provided in Appendix A.

3.3 Stormwater Management During Construction

The Site Contractor will be responsible for stormwater management of the active construction site and is required to adhere to the conditions of the 2017 Construction General Permit under the Environmental Protection Agency through the preparation and implementation of a Stormwater Pollution Prevention Plan (SWPPP). A draft SWPPP has been prepared in accordance with the MassDEP Stormwater Management Standards and the 2017 Construction General Permit (Appendix F).

4.0 STORMWATER MANAGEMENT ANALYSIS

4.1 Methodology

Nitsch Engineering completed a hydrologic analysis of the existing project site utilizing Soil Conservation Service (SCS) Runoff Curve Number (CN) methodology. The SCS method calculates the rate at which the runoff reaches the design point considering several factors: the slope and flow lengths of the subcatchment area, the soil type of the subcatchment area, and the type of surface cover in the subcatchment area. HydroCAD Version 10.00 computer modeling software was used in conjunction with the SCS method to determine the peak runoff rates and runoff volumes for the 2-, 10-, 25-, and 100-year, 24-hour storm events. The proposed project site is being analyzed with the same methodology.

SCS Runoff Curve Numbers (CNs) were selected by using the cover type and hydrologic soil group of each area. The peak runoff rates and runoff volumes for the 2-, 10-, 25- and 100-year 24-hour storm events were then determined by inputting the drainage areas, CNs, and time of concentration (T_c) paths into the HydroCAD model.

The National Oceanic and Atmospheric Administration Atlas 14 precipitation frequency estimates were used to calculate the 2-, 10-, 25-, and 100- year 24-hour storm events in HydroCAD. Refer to the HydroCAD calculations in Appendix B and C for rainfall information.

4.2 HydroCAD Version 10.00

The HydroCAD computer program uses SCS and TR-20 methods to model drainage systems. TR-20 (Technical Release 20) was developed by the Soil Conservation Service to estimate runoff and peak discharges in small watersheds. TR-20 is generally accepted by engineers and reviewing authorities as the standard method for estimating runoff and peak discharges.

HydroCAD Version 10.00 uses up to four types of components to analyze the hydrology of a given site: subcatchments, reaches, basins, and links. Subcatchments are areas of land that produce surface runoff. The area, weighted CN, and T_c characterize each individual subcatchment area. Reaches are generally uniform streams, channels, or pipes that convey water from one point to another. A basin is any impoundment that fills with water from one or more sources and empties via an outlet structure. Links are used to introduce hydrographs into a project from another source or to provide a junction for more than one hydrograph within a project. The time span for the model was set for 0-48 hours in order to prevent truncation of the hydrograph.

Modeling of Porous Asphalt Section

The porous asphalt systems were modeled according to methodology developed by the University of New Hampshire Stormwater Center (UNHSC). Under ideal conditions, porous asphalt with a suitable base will rapidly infiltrate several inches of water, resulting in no runoff in the traditional sense. However, the HydroCAD model needs to evaluate the “runoff” that is penetrating through the porous asphalt. This requires the use of a high CN (98) to capture most of the rainfall.

Once intercepted by the porous asphalt surface, the water will take some time to travel through the base layers of the roadway, before ponding in the voids of the stone base. The UNHSC has studied this behavior and developed an extended T_c value to simulate the travel time through the base. Their research determined that a T_c of over 1,000 minutes has produced good predictions of the final discharge from porous asphalt with a 41-inch base (measured above the underdrains). Nitsch is conservatively using a T_c of 60 minutes in the HydroCAD model. Refer to Appendix H for the time of concentration documentation for the porous asphalt sections by UNH.

4.3 Existing and Proposed Hydrologic Conditions

Nitsch Engineering utilized an existing conditions survey and on-site observations to put together an existing conditions hydrologic model for the site (See Figure DR-1). The HydroCAD model for existing conditions is provided in Appendix B and results from the calculations are summarized in Table 3.

The proposed project has been designed to mitigate the change in stormwater runoff from the site as required by the MADEP Stormwater Management Standards and the Boston Water and Sewer Commission. The existing watershed areas were modified to reflect the proposed topography, storm drainage structures and BMPs, and roof areas. (See Figure DR-2). The HydroCAD model for proposed conditions is provided in Appendix C and results from the calculations are summarized in Table 3.

4.4 Peak Flow Rates

The proposed stormwater management system is expected to reduce the proposed peak runoff rates to at or below the existing rates. Table 3 below summarizes the existing and proposed hydrologic analyses for the site.

Table 3 – Peak Rates of Runoff in Cubic Feet per Second (cfs)

Storm Event	2-year	10-year	25-year	100-year
Existing	13.04	20.70	25.50	32.89
Proposed	8.87	18.28	22.81	29.95

5.0 MassDEP Stormwater Management Standards

The Project is considered a **redevelopment** under the DEP Stormwater Management System. As such, the project is required to meet Standards 2, 3, and the pretreatment and structural best management practice requirements of Standards 4,5, and 6 only to the maximum extent practicable. Existing stormwater discharges need to comply with Standard 1 only to the maximum extent practicable. The project will comply with all other Standards. The site will be designed to meet or meet to the maximum extent practicable the MassDEP Stormwater Management Standards as summarized below:

Standard 1: No New Untreated Discharges

The Project will not discharge any untreated stormwater directly to or cause erosion in wetlands or waters of the Commonwealth. Stormwater from the Site will be collected and treated in accordance with the MassDEP Stormwater Management Standards and stormwater outfalls will be stabilized to prevent erosion.

Standard 2: Peak Rate Attenuation

The proposed stormwater management system will be designed so that the post-development peak discharge rates do not exceed pre-development peak discharge rates. To prevent storm damage and downstream flooding, the proposed stormwater management practices will mitigate peak runoff rates for the 2-, 10-, 25- and 100-year, 24-hour storm events. Refer to Table 3 for a pre- and post-development peak runoff rate comparison.

Standard 3: Groundwater Recharge

The Site was designed using low impact development techniques, and stormwater BMP treatment trains to minimize the loss of annual recharge to groundwater. The annual recharge from the post-development site will approximate the annual recharge from pre-development conditions based on soil type using the guidelines provided in the MassDEP Stormwater Management Handbook.

Impervious Area in HSG C = 175,900 square feet
 Rv (Recharge Volume) = 175,900 x 0.25 in. / (12 inches/ft)
 = 3,665 cubic feet

Total Required Recharge Volume = 3,665 cubic feet

The infiltration BMPs are sized to exceed the recharge volume required under the MassDEP Stormwater Management Standards (Table 4)

Table 4 – Proposed Recharge Volumes for Stormwater BMPs

Infiltration BMP	Recharge Volume (cf)
Tank/Underground Infiltration System 1	14,500
Underground Infiltration System 2	4,100
Total	20,600

72-hour draw down calculations have been provided in Appendix A.

A minimum 2 feet but less than 4 feet of separation has been maintained between the bottom of the infiltration system and seasonal high groundwater. Groundwater mounding calculations have been provided in Appendix A.

Standard 4: Water Quality Treatment

The proposed stormwater management system will be designed to remove greater than 80% of the average annual post-construction load of Total Suspended Solids (TSS). Structural stormwater BMPs including deep-sump and hooded catch basins, porous asphalt, subsurface infiltration systems, and water quality units are sized to capture the required water quality volume and remove a minimum of 80% of total suspended solids.

Table 5. Proposed Treatment Train Summary

Watershed	Treatment Train
DA1	Deep Sump and Hooded Catch Basin- Water Quality Structure- Subsurface Infiltration System
DA2	Deep Sump and Hooded Catch Basin- Water Quality Structure- Subsurface Infiltration System
DA3	Porous Asphalt- Subsurface Infiltration System

Pretreatment for the subsurface infiltration systems will be provided using deep-sump and hooded catch basins and water quality units that have been sized using the flow rate associated with the water quality volume. The porous asphalt sections were designed in accordance with the University of New Hampshire Design Specifications for Porous Asphalt Pavement and Infiltration Beds and include an 8-inch filter course of bank run gravel to provide water quality treatment prior to flowing into the reservoir course.

TSS removal calculation spreadsheets and water quality structure sizing calculations are provided in Appendix A.

Source control and pollution prevention measures, such as vacuum cleaning, street sweeping, proper snow management, and stabilization of eroded surfaces, are included in the Long-Term Pollution Prevention Plan and Operation and Maintenance Plan (Appendix E).

Standard 5: Land Uses with Higher Potential Pollutant Loads

The project is not considered a LUHPPL and therefore, this standard is not applicable.

Standard 6: Critical Areas

The Project is not located within any critical areas. Therefore, this standard is not applicable.

Standard 7: Redevelopments

The Project is considered a redevelopment under the MassDEP Stormwater Management Standards. Therefore, the project is required to meet Standard 2, Standard 3, and the pretreatment and structural stormwater BMP requirements of Standards 4, 5, and 6 to the maximum extent practicable. The projects should comply with all other requirements of the Stormwater Management Standards and improve existing conditions. The Project meets this standard.

Standard 8: Construction Period Pollution Prevention and Sedimentation Control

A plan to control construction-related impacts, including erosion, sedimentation, and other pollutant sources during construction and land disturbance activities (construction period erosion, sedimentation, and pollution prevention plan) will be developed and implemented during the Notice of Intent permitting process.

Because the Project will disturb more than one (1) acre of land, a Notice of Intent will be submitted to the Environmental Protection Agency (EPA) for coverage under the National Pollution Discharge Elimination System (NPDES) Construction General Permit. As part of this application the Applicant is required to prepare a Stormwater Pollution Prevention Plan (SWPPP) and implement the measures

in the SWPPP. The SWPPP, which is to be kept on site, includes erosion and sediment controls (stabilization practices and structural practices), temporary and permanent stormwater management measures, Contractor inspection schedules and reporting of all SWPPP features, materials management, waste disposal, off-site vehicle tracking, spill prevention and response, sanitation, and non-stormwater discharges. A draft SWPPP is provided in Appendix F.

Standard 9: Operation and Maintenance Plan

A post-construction operation and maintenance plan has been prepared and will be implemented to ensure that stormwater management systems function as designed. Source control and stormwater BMP operation requirements for the site are summarized in the Long-Term Pollution Prevention Plan and Operation and Maintenance Plan provided in Appendix E.

Standard 10: Prohibition of Illicit Discharges

There will be no illicit discharges to the stormwater management system associated with the Project. An Illicit Discharge Compliance Statement is provided in Appendix A.

6.0 CLOSED DRAINAGE SYSTEM DESIGN

The proposed closed drainage system consists of deep-sump and hooded catch basins, drainage manholes, and proprietary water quality treatment units connected with corrugated polyethylene pipe. The closed drainage system was designed to convey the 25-year storm event using the Rational method. Refer to Appendix D for more information.

7.0 CONCLUSION

In conclusion, the Project's stormwater management system will reduce or maintain peak runoff rates and volumes through the use of infiltration BMPs and improve the water quality of stormwater being discharged from the Site. The Project is being designed to meet and exceed the MassDEP Stormwater Management Standards and the Boston Water and Sewer Commission requirements.

FIGURES

DR-1 Existing Watershed Areas

DR-2 Proposed Watershed Areas

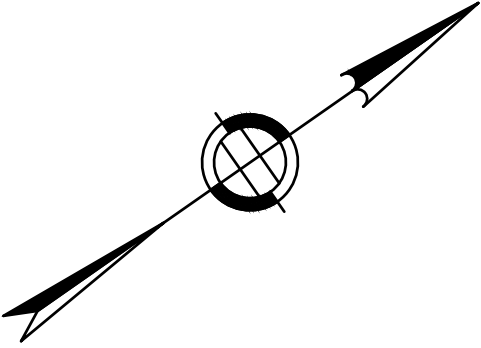
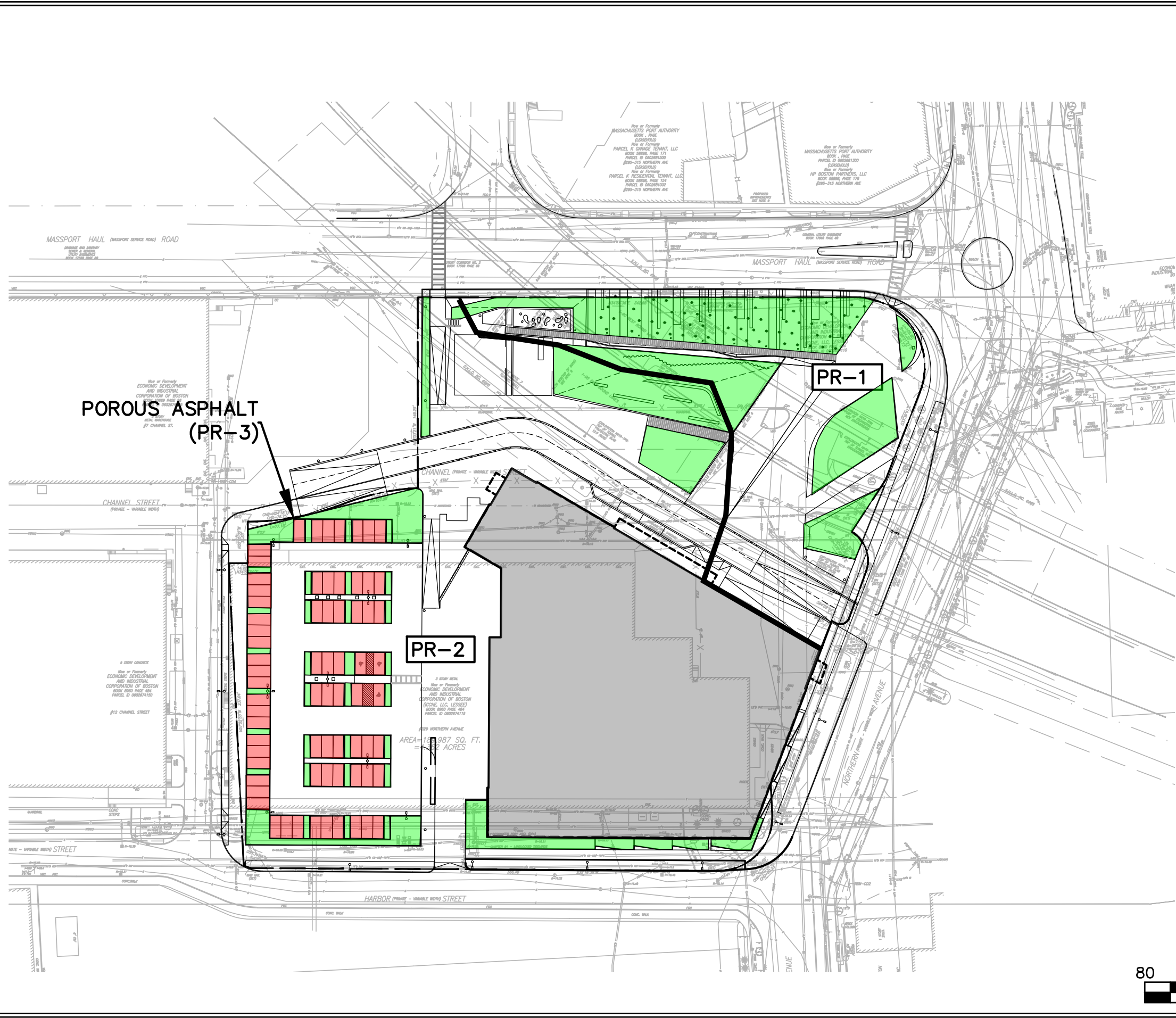

Legend:

- Pervious
- Impervious
- Roof
- Porous Asphalt

SCALE:
1" = 80'

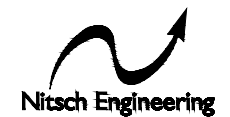
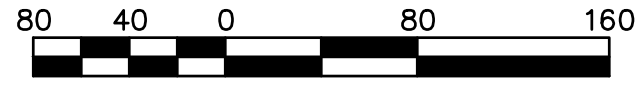

Nitsch Engineering

www.nitscheng.com
 2 Center Plaza, Suite 430
 Boston, MA 02108
 T: (617) 338-0063
 F: (617) 338-6472

- ▶ Civil Engineering
- ▶ Land Surveying
- ▶ Transportation Engineering
- ▶ Structural Engineering
- ▶ Green Infrastructure
- ▶ Planning
- ▶ GIS

**FIGURE 2
PROPOSED WATERSHED FIGURE**

PROJECT #	13569
SCALE:	1"=80'
DATE:	4/15/2021
PROJECT MGR:	CH
SURVEYOR:	FELDMAN
DRAFTED BY:	GG
CHECKED BY:	BV

APPENDIX A

Stormwater Management Standards Documentation

MassDEP Checklist for Stormwater Report

Standard 4: TSS Removal Calculations

Standard 4: Proprietary Water Quality Structure Calculations

Standard 10: Illicit Discharge Compliance Statement



Checklist for Stormwater Report

A. Introduction

Important: When filling out forms on the computer, use only the tab key to move your cursor - do not use the return key.



A Stormwater Report must be submitted with the Notice of Intent permit application to document compliance with the Stormwater Management Standards. The following checklist is NOT a substitute for the Stormwater Report (which should provide more substantive and detailed information) but is offered here as a tool to help the applicant organize their Stormwater Management documentation for their Report and for the reviewer to assess this information in a consistent format. As noted in the Checklist, the Stormwater Report must contain the engineering computations and supporting information set forth in Volume 3 of the [Massachusetts Stormwater Handbook](#). The Stormwater Report must be prepared and certified by a Registered Professional Engineer (RPE) licensed in the Commonwealth.

The Stormwater Report must include:

- The Stormwater Checklist completed and stamped by a Registered Professional Engineer (see page 2) that certifies that the Stormwater Report contains all required submittals.¹ This Checklist is to be used as the cover for the completed Stormwater Report.
- Applicant/Project Name
- Project Address
- Name of Firm and Registered Professional Engineer that prepared the Report
- Long-Term Pollution Prevention Plan required by Standards 4-6
- Construction Period Pollution Prevention and Erosion and Sedimentation Control Plan required by Standard 8²
- Operation and Maintenance Plan required by Standard 9

In addition to all plans and supporting information, the Stormwater Report must include a brief narrative describing stormwater management practices, including environmentally sensitive site design and LID techniques, along with a diagram depicting runoff through the proposed BMP treatment train. Plans are required to show existing and proposed conditions, identify all wetland resource areas, NRCS soil types, critical areas, Land Uses with Higher Potential Pollutant Loads (LUHPPL), and any areas on the site where infiltration rate is greater than 2.4 inches per hour. The Plans shall identify the drainage areas for both existing and proposed conditions at a scale that enables verification of supporting calculations.

As noted in the Checklist, the Stormwater Management Report shall document compliance with each of the Stormwater Management Standards as provided in the Massachusetts Stormwater Handbook. The soils evaluation and calculations shall be done using the methodologies set forth in Volume 3 of the Massachusetts Stormwater Handbook.

To ensure that the Stormwater Report is complete, applicants are required to fill in the Stormwater Report Checklist by checking the box to indicate that the specified information has been included in the Stormwater Report. If any of the information specified in the checklist has not been submitted, the applicant must provide an explanation. The completed Stormwater Report Checklist and Certification must be submitted with the Stormwater Report.

¹ The Stormwater Report may also include the Illicit Discharge Compliance Statement required by Standard 10. If not included in the Stormwater Report, the Illicit Discharge Compliance Statement must be submitted prior to the discharge of stormwater runoff to the post-construction best management practices.

² For some complex projects, it may not be possible to include the Construction Period Erosion and Sedimentation Control Plan in the Stormwater Report. In that event, the issuing authority has the discretion to issue an Order of Conditions that approves the project and includes a condition requiring the proponent to submit the Construction Period Erosion and Sedimentation Control Plan before commencing any land disturbance activity on the site.



Checklist for Stormwater Report

B. Stormwater Checklist and Certification

The following checklist is intended to serve as a guide for applicants as to the elements that ordinarily need to be addressed in a complete Stormwater Report. The checklist is also intended to provide conservation commissions and other reviewing authorities with a summary of the components necessary for a comprehensive Stormwater Report that addresses the ten Stormwater Standards.

Note: Because stormwater requirements vary from project to project, it is possible that a complete Stormwater Report may not include information on some of the subjects specified in the Checklist. If it is determined that a specific item does not apply to the project under review, please note that the item is not applicable (N.A.) and provide the reasons for that determination.

A complete checklist must include the Certification set forth below signed by the Registered Professional Engineer who prepared the Stormwater Report.

Registered Professional Engineer's Certification

I have reviewed the Stormwater Report, including the soil evaluation, computations, Long-term Pollution Prevention Plan, the Construction Period Erosion and Sedimentation Control Plan (if included), the Long-term Post-Construction Operation and Maintenance Plan, the Illicit Discharge Compliance Statement (if included) and the plans showing the stormwater management system, and have determined that they have been prepared in accordance with the requirements of the Stormwater Management Standards as further elaborated by the Massachusetts Stormwater Handbook. I have also determined that the information presented in the Stormwater Checklist is accurate and that the information presented in the Stormwater Report accurately reflects conditions at the site as of the date of this permit application.

Registered Professional Engineer Block and Signature

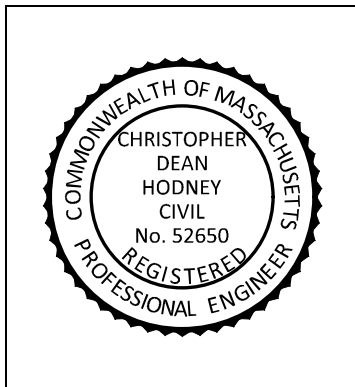

4/16/2021

Signature and Date

Checklist

Project Type: Is the application for new development, redevelopment, or a mix of new and redevelopment?

- New development
- Redevelopment
- Mix of New Development and Redevelopment



Checklist for Stormwater Report

Checklist (continued)

LID Measures: Stormwater Standards require LID measures to be considered. Document what environmentally sensitive design and LID Techniques were considered during the planning and design of the project:

- No disturbance to any Wetland Resource Areas
- Site Design Practices (e.g. clustered development, reduced frontage setbacks)
- Reduced Impervious Area (Redevelopment Only)
- Minimizing disturbance to existing trees and shrubs
- LID Site Design Credit Requested:
 - Credit 1
 - Credit 2
 - Credit 3
- Use of “country drainage” versus curb and gutter conveyance and pipe
- Bioretention Cells (includes Rain Gardens)
- Constructed Stormwater Wetlands (includes Gravel Wetlands designs)
- Treebox Filter
- Water Quality Swale
- Grass Channel
- Green Roof
- Other (describe): _____

Standard 1: No New Untreated Discharges

- No new untreated discharges
- Outlets have been designed so there is no erosion or scour to wetlands and waters of the Commonwealth
- Supporting calculations specified in Volume 3 of the Massachusetts Stormwater Handbook included.



Checklist for Stormwater Report

Checklist (continued)

Standard 2: Peak Rate Attenuation

- Standard 2 waiver requested because the project is located in land subject to coastal storm flowage and stormwater discharge is to a wetland subject to coastal flooding.
- Evaluation provided to determine whether off-site flooding increases during the 100-year 24-hour storm.
- Calculations provided to show that post-development peak discharge rates do not exceed pre-development rates for the 2-year and 10-year 24-hour storms. If evaluation shows that off-site flooding increases during the 100-year 24-hour storm, calculations are also provided to show that post-development peak discharge rates do not exceed pre-development rates for the 100-year 24-hour storm.

Standard 3: Recharge

- Soil Analysis provided.
- Required Recharge Volume calculation provided.
- Required Recharge volume reduced through use of the LID site Design Credits.
- Sizing the infiltration, BMPs is based on the following method: Check the method used.
 - Static
 - Simple Dynamic
 - Dynamic Field¹
- Runoff from all impervious areas at the site discharging to the infiltration BMP.
- Runoff from all impervious areas at the site is *not* discharging to the infiltration BMP and calculations are provided showing that the drainage area contributing runoff to the infiltration BMPs is sufficient to generate the required recharge volume.
- Recharge BMPs have been sized to infiltrate the Required Recharge Volume.
- Recharge BMPs have been sized to infiltrate the Required Recharge Volume *only* to the maximum extent practicable for the following reason:
 - Site is comprised solely of C and D soils and/or bedrock at the land surface
 - M.G.L. c. 21E sites pursuant to 310 CMR 40.0000
 - Solid Waste Landfill pursuant to 310 CMR 19.000
 - Project is otherwise subject to Stormwater Management Standards only to the maximum extent practicable.
- Calculations showing that the infiltration BMPs will drain in 72 hours are provided.
- Property includes a M.G.L. c. 21E site or a solid waste landfill and a mounding analysis is included.

¹ 80% TSS removal is required prior to discharge to infiltration BMP if Dynamic Field method is used.



Checklist for Stormwater Report

Checklist (continued)

Standard 3: Recharge (continued)

- The infiltration BMP is used to attenuate peak flows during storms greater than or equal to the 10-year 24-hour storm and separation to seasonal high groundwater is less than 4 feet and a mounding analysis is provided.
- Documentation is provided showing that infiltration BMPs do not adversely impact nearby wetland resource areas.

Standard 4: Water Quality

The Long-Term Pollution Prevention Plan typically includes the following:

- Good housekeeping practices;
 - Provisions for storing materials and waste products inside or under cover;
 - Vehicle washing controls;
 - Requirements for routine inspections and maintenance of stormwater BMPs;
 - Spill prevention and response plans;
 - Provisions for maintenance of lawns, gardens, and other landscaped areas;
 - Requirements for storage and use of fertilizers, herbicides, and pesticides;
 - Pet waste management provisions;
 - Provisions for operation and management of septic systems;
 - Provisions for solid waste management;
 - Snow disposal and plowing plans relative to Wetland Resource Areas;
 - Winter Road Salt and/or Sand Use and Storage restrictions;
 - Street sweeping schedules;
 - Provisions for prevention of illicit discharges to the stormwater management system;
 - Documentation that Stormwater BMPs are designed to provide for shutdown and containment in the event of a spill or discharges to or near critical areas or from LUHPPL;
 - Training for staff or personnel involved with implementing Long-Term Pollution Prevention Plan;
 - List of Emergency contacts for implementing Long-Term Pollution Prevention Plan.
- A Long-Term Pollution Prevention Plan is attached to Stormwater Report and is included as an attachment to the Wetlands Notice of Intent.
 - Treatment BMPs subject to the 44% TSS removal pretreatment requirement and the one inch rule for calculating the water quality volume are included, and discharge:
 - is within the Zone II or Interim Wellhead Protection Area
 - is near or to other critical areas
 - is within soils with a rapid infiltration rate (greater than 2.4 inches per hour)
 - involves runoff from land uses with higher potential pollutant loads.
 - The Required Water Quality Volume is reduced through use of the LID site Design Credits.
 - Calculations documenting that the treatment train meets the 80% TSS removal requirement and, if applicable, the 44% TSS removal pretreatment requirement, are provided.



Checklist for Stormwater Report

Checklist (continued)

Standard 4: Water Quality (continued)

- The BMP is sized (and calculations provided) based on:
 - The ½" or 1" Water Quality Volume or
 - The equivalent flow rate associated with the Water Quality Volume and documentation is provided showing that the BMP treats the required water quality volume.
- The applicant proposes to use proprietary BMPs, and documentation supporting use of proprietary BMP and proposed TSS removal rate is provided. This documentation may be in the form of the propriety BMP checklist found in Volume 2, Chapter 4 of the Massachusetts Stormwater Handbook and submitting copies of the TARP Report, STEP Report, and/or other third party studies verifying performance of the proprietary BMPs.
- A TMDL exists that indicates a need to reduce pollutants other than TSS and documentation showing that the BMPs selected are consistent with the TMDL is provided.

Standard 5: Land Uses With Higher Potential Pollutant Loads (LUHPPLs)

- The NPDES Multi-Sector General Permit covers the land use and the Stormwater Pollution Prevention Plan (SWPPP) has been included with the Stormwater Report.
- The NPDES Multi-Sector General Permit covers the land use and the SWPPP will be submitted **prior to** the discharge of stormwater to the post-construction stormwater BMPs.
- The NPDES Multi-Sector General Permit does **not** cover the land use.
- LUHPPLs are located at the site and industry specific source control and pollution prevention measures have been proposed to reduce or eliminate the exposure of LUHPPLs to rain, snow, snow melt and runoff, and been included in the long term Pollution Prevention Plan.
- All exposure has been eliminated.
- All exposure has **not** been eliminated and all BMPs selected are on MassDEP LUHPPL list.
- The LUHPPL has the potential to generate runoff with moderate to higher concentrations of oil and grease (e.g. all parking lots with >1000 vehicle trips per day) and the treatment train includes an oil grit separator, a filtering bioretention area, a sand filter or equivalent.

Standard 6: Critical Areas

- The discharge is near or to a critical area and the treatment train includes only BMPs that MassDEP has approved for stormwater discharges to or near that particular class of critical area.
- Critical areas and BMPs are identified in the Stormwater Report.



Checklist for Stormwater Report

Checklist (continued)

Standard 7: Redevelopments and Other Projects Subject to the Standards only to the maximum extent practicable

- The project is subject to the Stormwater Management Standards only to the maximum Extent Practicable as a:
- Limited Project
 - Small Residential Projects: 5-9 single family houses or 5-9 units in a multi-family development provided there is no discharge that may potentially affect a critical area.
 - Small Residential Projects: 2-4 single family houses or 2-4 units in a multi-family development with a discharge to a critical area
 - Marina and/or boatyard provided the hull painting, service and maintenance areas are protected from exposure to rain, snow, snow melt and runoff
 - Bike Path and/or Foot Path
 - Redevelopment Project
 - Redevelopment portion of mix of new and redevelopment.
- Certain standards are not fully met (Standard No. 1, 8, 9, and 10 must always be fully met) and an explanation of why these standards are not met is contained in the Stormwater Report.
- The project involves redevelopment and a description of all measures that have been taken to improve existing conditions is provided in the Stormwater Report. The redevelopment checklist found in Volume 2 Chapter 3 of the Massachusetts Stormwater Handbook may be used to document that the proposed stormwater management system (a) complies with Standards 2, 3 and the pretreatment and structural BMP requirements of Standards 4-6 to the maximum extent practicable and (b) improves existing conditions.

Standard 8: Construction Period Pollution Prevention and Erosion and Sedimentation Control

A Construction Period Pollution Prevention and Erosion and Sedimentation Control Plan must include the following information:

- Narrative;
 - Construction Period Operation and Maintenance Plan;
 - Names of Persons or Entity Responsible for Plan Compliance;
 - Construction Period Pollution Prevention Measures;
 - Erosion and Sedimentation Control Plan Drawings;
 - Detail drawings and specifications for erosion control BMPs, including sizing calculations;
 - Vegetation Planning;
 - Site Development Plan;
 - Construction Sequencing Plan;
 - Sequencing of Erosion and Sedimentation Controls;
 - Operation and Maintenance of Erosion and Sedimentation Controls;
 - Inspection Schedule;
 - Maintenance Schedule;
 - Inspection and Maintenance Log Form.
- A Construction Period Pollution Prevention and Erosion and Sedimentation Control Plan containing the information set forth above has been included in the Stormwater Report.



Checklist for Stormwater Report

Checklist (continued)

Standard 8: Construction Period Pollution Prevention and Erosion and Sedimentation Control (continued)

- The project is highly complex and information is included in the Stormwater Report that explains why it is not possible to submit the Construction Period Pollution Prevention and Erosion and Sedimentation Control Plan with the application. A Construction Period Pollution Prevention and Erosion and Sedimentation Control has **not** been included in the Stormwater Report but will be submitted **before** land disturbance begins.
- The project is **not** covered by a NPDES Construction General Permit.
- The project is covered by a NPDES Construction General Permit and a copy of the SWPPP is in the Stormwater Report.
- The project is covered by a NPDES Construction General Permit but no SWPPP been submitted. The SWPPP will be submitted BEFORE land disturbance begins.

Standard 9: Operation and Maintenance Plan

- The Post Construction Operation and Maintenance Plan is included in the Stormwater Report and includes the following information:
 - Name of the stormwater management system owners;
 - Party responsible for operation and maintenance;
 - Schedule for implementation of routine and non-routine maintenance tasks;
 - Plan showing the location of all stormwater BMPs maintenance access areas;
 - Description and delineation of public safety features;
 - Estimated operation and maintenance budget; and
 - Operation and Maintenance Log Form.
- The responsible party is **not** the owner of the parcel where the BMP is located and the Stormwater Report includes the following submissions:
 - A copy of the legal instrument (deed, homeowner's association, utility trust or other legal entity) that establishes the terms of and legal responsibility for the operation and maintenance of the project site stormwater BMPs;
 - A plan and easement deed that allows site access for the legal entity to operate and maintain BMP functions.

Standard 10: Prohibition of Illicit Discharges

- The Long-Term Pollution Prevention Plan includes measures to prevent illicit discharges;
- An Illicit Discharge Compliance Statement is attached;
- NO Illicit Discharge Compliance Statement is attached but will be submitted **prior to** the discharge of any stormwater to post-construction BMPs.

**2 Harbor Street
WATER QUALITY TREATMENT SUMMARY (04/15/2021)**

Nitsch Engineering has prepared this Water Quality Treatment Summary for the development at 2 Harbor Street in Boston's Seaport Neighborhood. In compliance with MassDEP Stormwater Management Standard #4, the proposed stormwater management system is designed to remove at least 80% of the average annual post-construction load of TSS prior to discharge. The stormwater management system is designed to remove at least 44% of the average annual post-construction TSS load prior to discharge to the infiltration systems because the infiltration systems are located within areas where soils with rapid infiltration rates were observed.

A summary of treatment trains proposed to provide water quantity control and water quality improvement at the proposed project site is provided below.

Treatment Train A

Catchment Area: PR1 + PR2

Deep Sump & Hooded Catch Basin → Water Quality Structure → Infiltration Basin → Discharge

Treatment Train B

Catchment Areas: PR3

Porous Asphalt → Infiltration → Discharge



Treatment Train A (PR1 + PR2) :

Deep Sump & Hooded Catch Basin → Water Quality Structure → Infiltration Basin → Discharge

Treatment Spreadsheet

B BMP	C TSS Removal Rate	D Starting TSS Load	E Amount Removed (C*D)	F Remaining Load (D-E)
Deep Sump & Hooded Catch Basin	0.25	1.00	0.25	0.75
Water Quality Structure	0.80	0.75	0.60	0.15
Infiltration System	0.80	0.15	0.12	0.03

Total TSS
Removal =

97%

**Meets 80% TSS
removal
requirement**



Treatment Train b (pr3) :

Porous Asphalt → Infiltration → Discharge

Treatment Spreadsheet

B BMP	C TSS Removal Rate	D Starting TSS Load	E Amount Removed (C*D)	F Remaining Load (D-E)
Porous Asphalt	0.80	1.00	0.80	0.20
Infiltration System	0.80	0.20	0.16	0.04

Total TSS
Removal =

96%

**Meets 80% TSS
removal
requirement**



Nitsch Job # 13569
 Calc: WQV
 Date: 4/15/2021

1" Calculation Sheet

This spreadsheet should be used to convert water quality volume to an equivalent water quality peak flow rate as outlined in the new MA DEP guidelines that take effect on October 15, 2013.

Glossary

Water Quality Flow Rate = WQF
 Water Quality Volume = WQV*
 unit peak discharge (csm/in) = qu**
 Impervious Area in watershed (square miles) = Ai

*WQV is expressed in watershed inches (you must use 1.0-inches in all cases with this method and not 0.5-inches)

** calculate the qu based on the time of concentration (see 1" - qu Table)

Compute Water Quality Flow with the following Equation

$$WQF = (qu)(A)(WQV)$$

Input Information (in colored cells only)

Site Plan Callout	Enter qu (from 1" - qu Table)	Enter Impervious Area (SF)	Ai (sq/mi)	WQV	WQF	
WQS500	774	25153	0.000902	1	=	0.70 cfs
WQS501	774	68629	0.002462	1	=	1.91 cfs
			0.000000	1	=	0.00 cfs
			0.000000	1	=	0.00 cfs
			0.000000	1	=	0.00 cfs
			0.000000	1	=	0.00 cfs
			0.000000	1	=	0.00 cfs
			0.000000	1	=	0.00 cfs
			0.000000	1	=	0.00 cfs
			0.000000	1	=	0.00 cfs



2 Center Plaza, Suite 430
 Boston, MA 02108-1928
 T: 617-338-0063
 F: 617-338-6472
www.nitscheng.com

Sediment Storage Calculation Sheet

Nitsch Job # 13569 Date: 4/15/2021
 Project Name: 2 Harbor
 Calculated by: GNG Checked by: BV
 Water Quality ID: WQS500

This spreadsheet should be used to calculate the required amount of sediment storage for proposed water quality units.

Assumptions:

	150	mg/L	TSS Loading
	42	inches	Annual Rainfall - Boston Area
	2650	kg/m ³	SG
	80%		TSS Removal
	3	years	Storage Capacity

Input:

Drainage Area: 1 acres
 % Impervious: 58.00% of area

Volume of Runoff: 88426.800 cf/year = 2503.964 m³/year

Loading: 0.150 kg/m³

Sediment: 375.595 kg/year = 0.142 m³/year = 5.005 cf/year

Sediment Removal: 4.004 cf/year

**Sediment Storage
Required:**

15 cf

Notes

- 1) TSS Loading is a conservative estimate based on a study completed by Maestre and Pitt in 2005
- 2) Rainfall data is based on NOAA Atlas 14 Volume 10 for City of Boston.
- 3) Specific Gravity is based on the NJDEP testing requirements for dynamic separators.
- 4) TSS removal goal is for storage calculations only.
- 5) Providing 3 years of storage capacity as a factor of safety assuming yearly cleaning of WQS.



2 Center Plaza, Suite 430
 Boston, MA 02108-1928
 T: 617-338-0063
 F: 617-338-6472
 www.nitscheng.com

Sediment Storage Calculation Sheet

Nitsch Job # 13569 Date: 4/15/2021
 Project Name: 2 Harbor
 Calculated by: GNG Checked by: BV
 Water Quality ID: WQS501

This spreadsheet should be used to calculate the required amount of sediment storage for proposed water quality units.

Assumptions:

150	mg/L	TSS Loading
42	inches	Annual Rainfall - Boston Area
2650	kg/m ³	SG
80%		TSS Removal
3	years	Storage Capacity

Input:

Drainage Area: 3.1 acres } Input Project Specific
 % Impervious: 50.96% of area } Values

Volume of Runoff:

240850.210 cf/year = 6820.107 m³/year

Loading:

0.150 kg/m³

Sediment:

1023.016 kg/year = 0.386 m³/year = 13.633 cf/year

Sediment Removal:

10.906 cf/year

**Sediment Storage
Required:**

33 cf

Notes

- 1) TSS Loading is a conservative estimate based on a study completed by Maestre and Pitt in 2005
- 2) Rainfall data is based on NOAA Atlas 14 Volume 10 for City of Boston
- 3) Specific Gravity is based on the NJDEP testing requirements for dynamic separators.
- 4) TSS removal goal is for storage calculations only.
- 5) Providing 3 years of storage capacity as a factor of safety assuming yearly cleaning of WQS.

STANDARD 10: Illicit Discharge Compliance Statement

Project Name: 2 Harbor Street	Nitsch Project #: 13569
Location: Boston, MA	Checked by: CDH
Prepared by: BMV	Sheet No. 1 of 1
Date: 4/16/2021	

Standard 10 states: All illicit discharges to the stormwater management system are prohibited.

This is to verify:

1. Based on the information available there are no known or suspected illicit discharges to the stormwater management system at 2 Harbor Street site as defined in the MassDEP Stormwater Handbook.
2. The design of the stormwater system includes no proposed illicit discharges.



Chris Hodney, PE

4/16/2021

Date



HALEY & ALDRICH, INC.
465 Medford St.
Suite 2200
Boston, MA 02129
617.886.7400

15 April 2021
File No. 0200427-000

BCP-CG Harbor Property LLC
c/o Beacon Capital Partners
200 State Street, 5th Floor
Boston, Massachusetts 02109

Attention: Mr. Eric Ewer
Senior Vice President

Subject: Stormwater Storage and Infiltration Systems
2 Harbor Street/ 329 Northern Avenue
Boston, Massachusetts

Ladies and Gentlemen:

This letter summarizes analyses conducted by Haley & Aldrich to evaluate the effectiveness (i.e., mounding potential) for the subject project's stormwater storage and infiltration systems as it relates to complying with the Boston Water and Sewer Commission (BWSC) requirement to retain and infiltrate the 1.25-inch design storm volume for the impervious portion of the property (and the Leadership in Energy and Environmental Design (LEED) goal to retain and infiltrate the 1.15-inch design storm volume for the total footprint area of the property) to the subsurface within 72-hours in advance of overflow discharge to the local storm drain system servicing the project site.

Systems Description

Based on information provided to us by the project's Civil Engineer (Nitsch Engineering), the analyses described herein are based on a total stormwater runoff volume of 18,800 cubic feet (cf)/ 140,000 gallons that can be infiltrated from two separate systems identified as System 1 and System 2 (further subdivided as 2A and 2B) and as shown on the attached Drawing C-300 titled Site Utility Plan, prepared by Nitsch Engineering and dated 16 April 2021.

We understand that the System 1 design volume (14,500 cf/ 108,000 gallons) will be held within a tank positioned inside the building's one-level below grade parking structure, from which it will be pumped to an approximately 358 ft-long drainage gallery as generally shown in plan view on the attached Drawing C-300 and with cross-sectional details as shown on the attached Drawing C-500 titled Details I, prepared by Nitsch Engineering and dated 16 April 2021.

We also understand that the System 2 design volume (4,300 cf/ 32,000 gallons) will be collected from a network of area drains positioned throughout the project's planned greenscape/ hardscape improvements located to the north of the new building. Surface runoff from the area drains will be piped to two separate (2A and 2B) but connected storage/infiltration systems comprised of open-bottomed storm water storage chambers encapsulated by drainage stone as generally shown in plan

view on Drawing C-300; cross-sectional details of the drainage gallery are provided on the attached Drawing C-501 titled Details II, prepared by Nitsch Engineering and dated 16 April 2021.

Systems 1 and 2 (2A and 2B) are designed to facilitate infiltration of water into the miscellaneous fill soils anticipated to underlie the project site to a depth of about 20 ft below planned final site grades.

System Performance - Mounding Potential

Groundwater mounding occurs beneath stormwater management structures designed to infiltrate stormwater runoff. Concentrating recharge in a limited area can cause groundwater mounding that can affect/alter existing groundwater conditions resulting in unintended impacts to surface and subsurface structures and conditions. Following is a summary of results obtained from calculating groundwater mounding potential for Systems 1 and 2 (2A and 2B) using a widely known and accepted (although simplified) analytical method based on work by Hantush (1967).

The estimated mounding potential after 72-hours of infiltration directly below System 1 is 3.1 ft above static groundwater level, or El. 11.1 Boston City Base (BCB) assuming a season high groundwater elevation of El. 8 BCB. Estimated mounding potential for System 2A is 2.0 ft, or El. 10.0 BCB and for System 2B is 1.6 ft, or El. 9.6 BCB.

For all three cases, the mound height is for a short period of time and dissipates within a relatively small radial or lateral distance from the footprint of each infiltration system. A detailed summary of the analytical solution results is included in the attached Appendix A.

Closing

We trust that the above information meets your needs. If you have questions or wish to discuss the recommendations provided, do not hesitate to contact us.

Sincerely yours,
HALEY & ALDRICH, INC.



Michael Atwood, P.E.
Principal

Attachments

- Drawing C-300 titled Site Utility Plan, prepared by Nitsch Engineering, dated 16 April 2021
- Drawing C-500 titled Details I, prepared by Nitsch Engineering, dated 18 February 2021
- Drawing C-501 titled Details II, prepared by Nitsch Engineering, dated 18 February 2021
- Appendix A - Calculations

C: Nitsch Engineering; Attn: Brittney Veeck, Chris Hodney

2 HARBOR

329 NORTHERN AVE
BOSTON, MA 02210

OWNER
BCP-CG HARBOR PROPERTY LLC
C/O BEACON CAPITAL PARTNERS, LLC
200 STATE STREET, FIFTH FLOOR
BOSTON, MA 02109

ARCHITECT
HANDEL ARCHITECTS, LLP
69 CANAL ST, 2ND FLOOR
BOSTON, MA 02214
T: 617.651.4790

CONSULTING ARCHITECT
STUDIO ENEE
460 HILLSIDE AVE
NEEDHAM, MA 02494
T: 781.858.3011

CONSULTING ARCHITECT
TRIA
21 DRYDOCK AVE, SUITE 330W
BOSTON, MA 02210
T: 617.530.1620

CIVIL ENGINEER
NITSCH ENGINEERING, INC.
2 CENTER PLAZA #430
BOSTON, MA 02108
T: 617.338.0063

MEP ENGINEER & CODE CONSULTANT
COSENTINI ASSOCIATES
101 FEDERAL ST #600
BOSTON, MA 02110
T: 617.748.7800

STRUCTURAL ENGINEER
DESIMONE CONSULTING ENGINEERS
31 MILK ST, SUITE 1016
BOSTON, MA 02109
T: 617.936.4492

LANDSCAPE ARCHITECT
KLOPPER MARTIN DESIGN GROUP
69 CANAL ST, 2ND FLOOR
BOSTON, MA 02214
T: 617.227.2560

ENVELOPE CONSULTANT
CBI CONSULTING, LLC
250 DORCHESTER AVE
BOSTON, MA 02127
T: 617.268.8977

GEOTECHNICAL
HALEY & ALDRICH, INC.
465 MEDFORD ST, SUITE 2200
BOSTON, MA 02129
T: 617.886.7400

NOT FOR CONSTRUCTION

NO.	DATE	ISSUANCE
1	12/20/2019	CONCEPT PRICING
2	12/15/2020	50% SCHEMATIC DESIGN
3	2/18/2021	100% SCHEMATIC DESIGN
4	4/16/2021	EARLY SITE PACKAGE

KEY PLAN

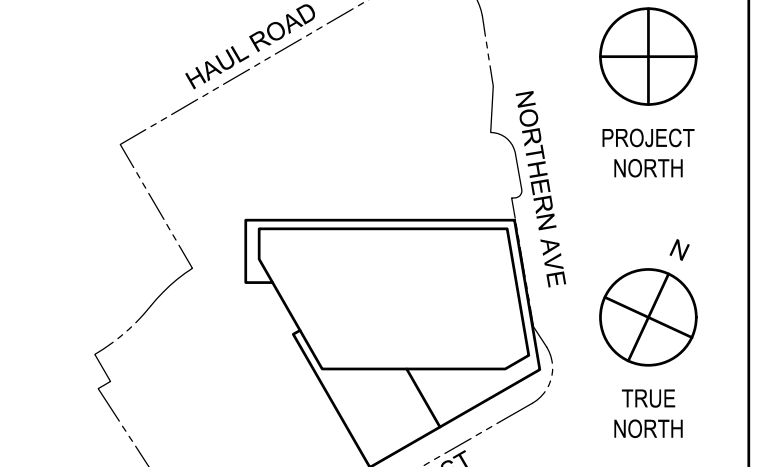

PROJECT DATUM: PROJ. 0'-0" = +16'-6" BCB
SCALE: 1" = 20'
PROJECT NO: 1550
SEAL & SIGNATURE

DRAWING TITLE:
SITE UTILITY PLAN

DRAWING NO:

C-300

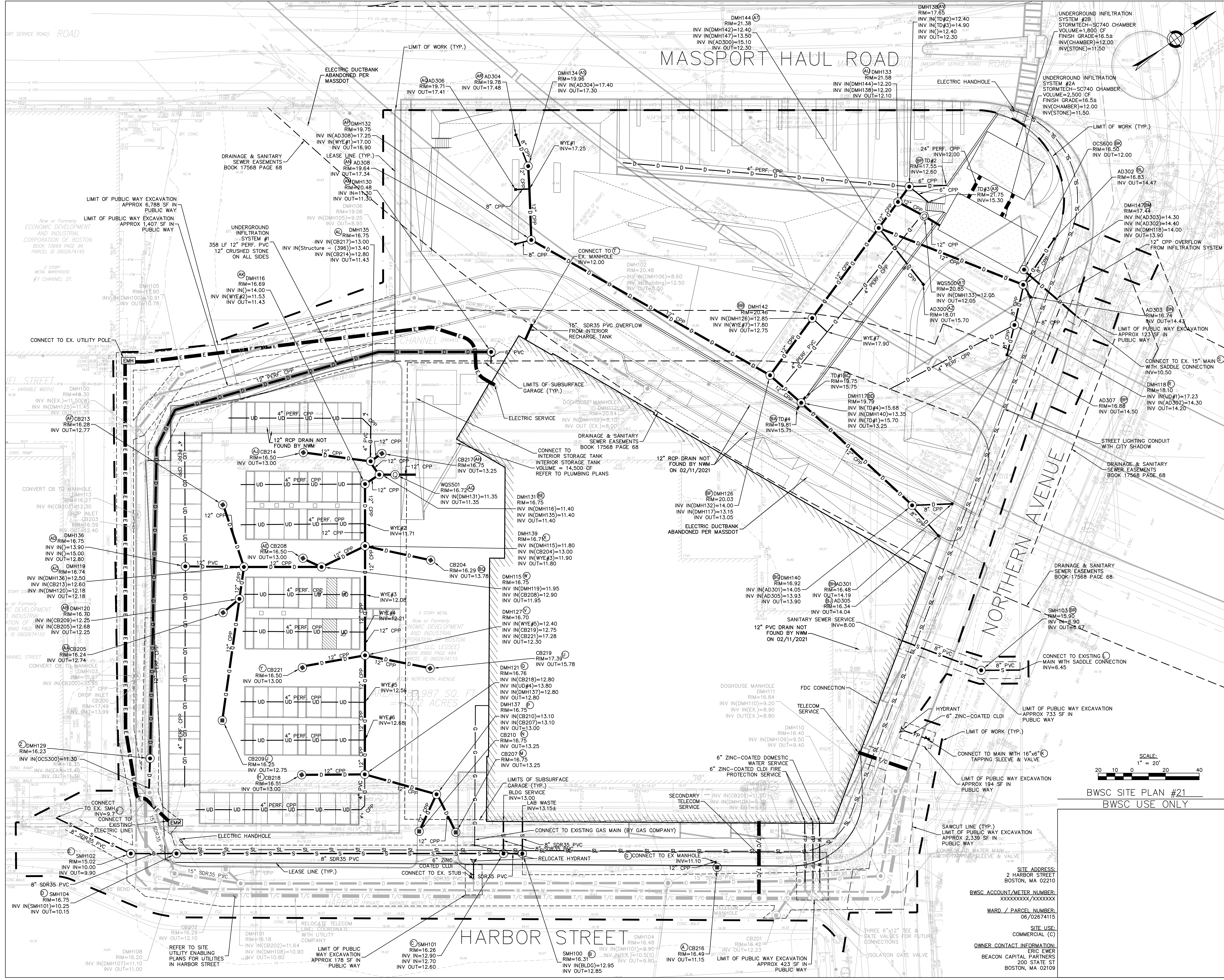

BWSC SITE PLAN #21
BWSC USE ONLY

SITE ADDRESS:
2 HARBOR STREET
BOSTON, MA 02210
BWSC ACCOUNT/METER NUMBER:
XXXXXXXX/XXXXXX
WARD / PARCEL NUMBER:
06/02674115
SITE USE:
COMMERCIAL (C)
OWNER CONTACT INFORMATION:
ERIC EWER
BEACON CAPITAL PARTNERS
200 STATE ST
BOSTON, MA 02109

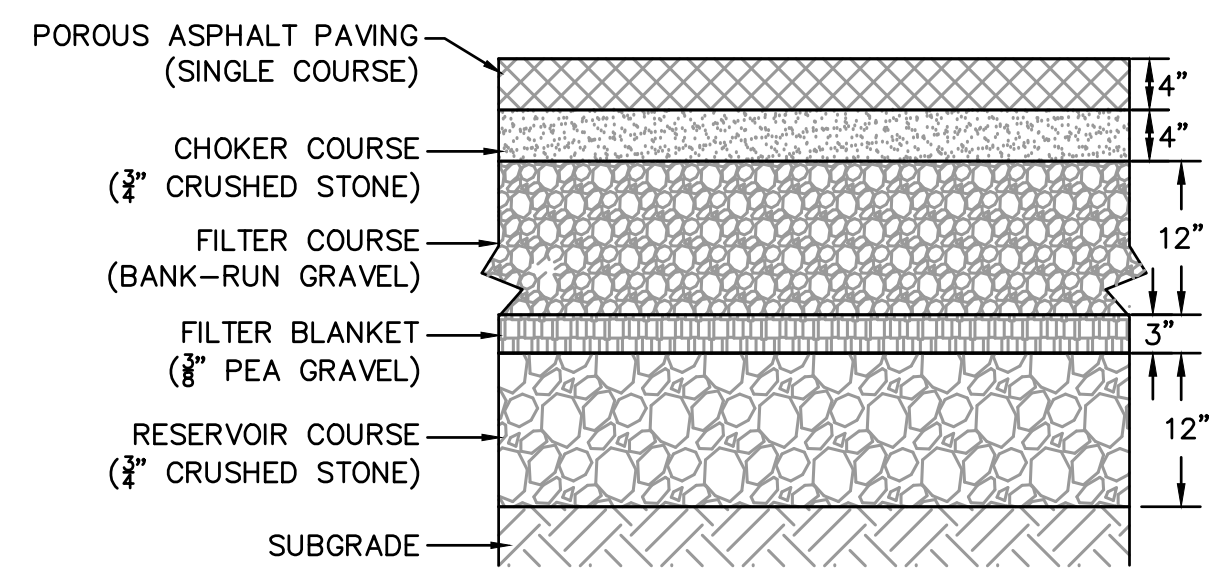

TYPICAL POROUS ASPHALT SECTION DETAIL
NOT TO SCALE

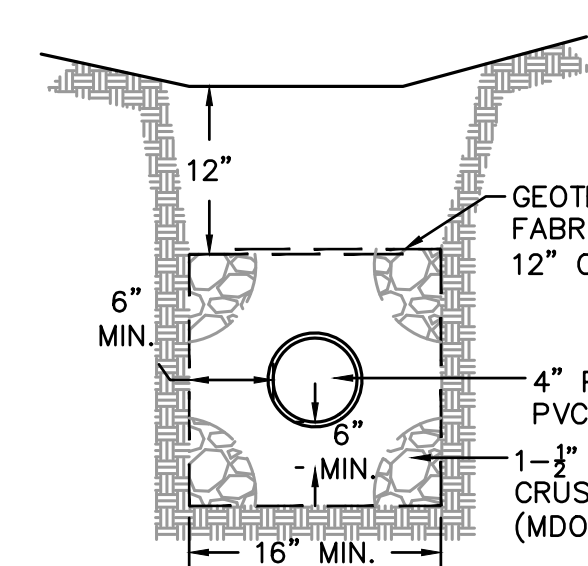

UNDERDRAIN DETAIL
NOT TO SCALE

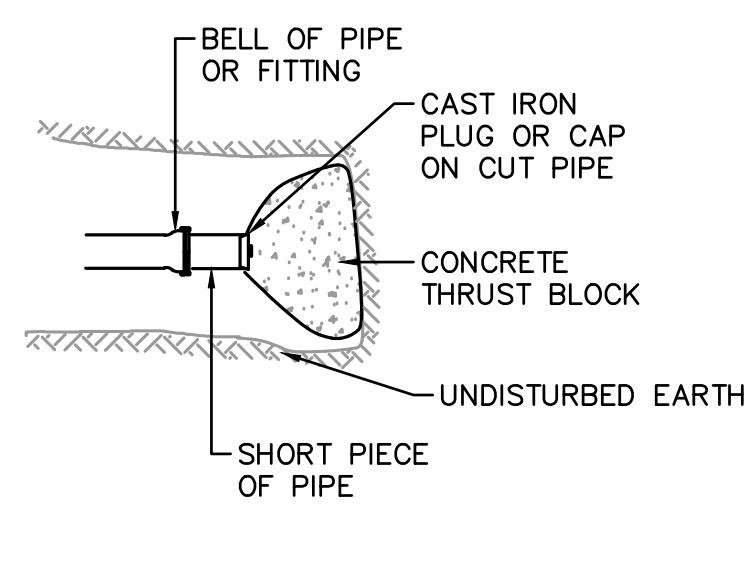

PLUG OR CAP DETAIL
NOT TO SCALE

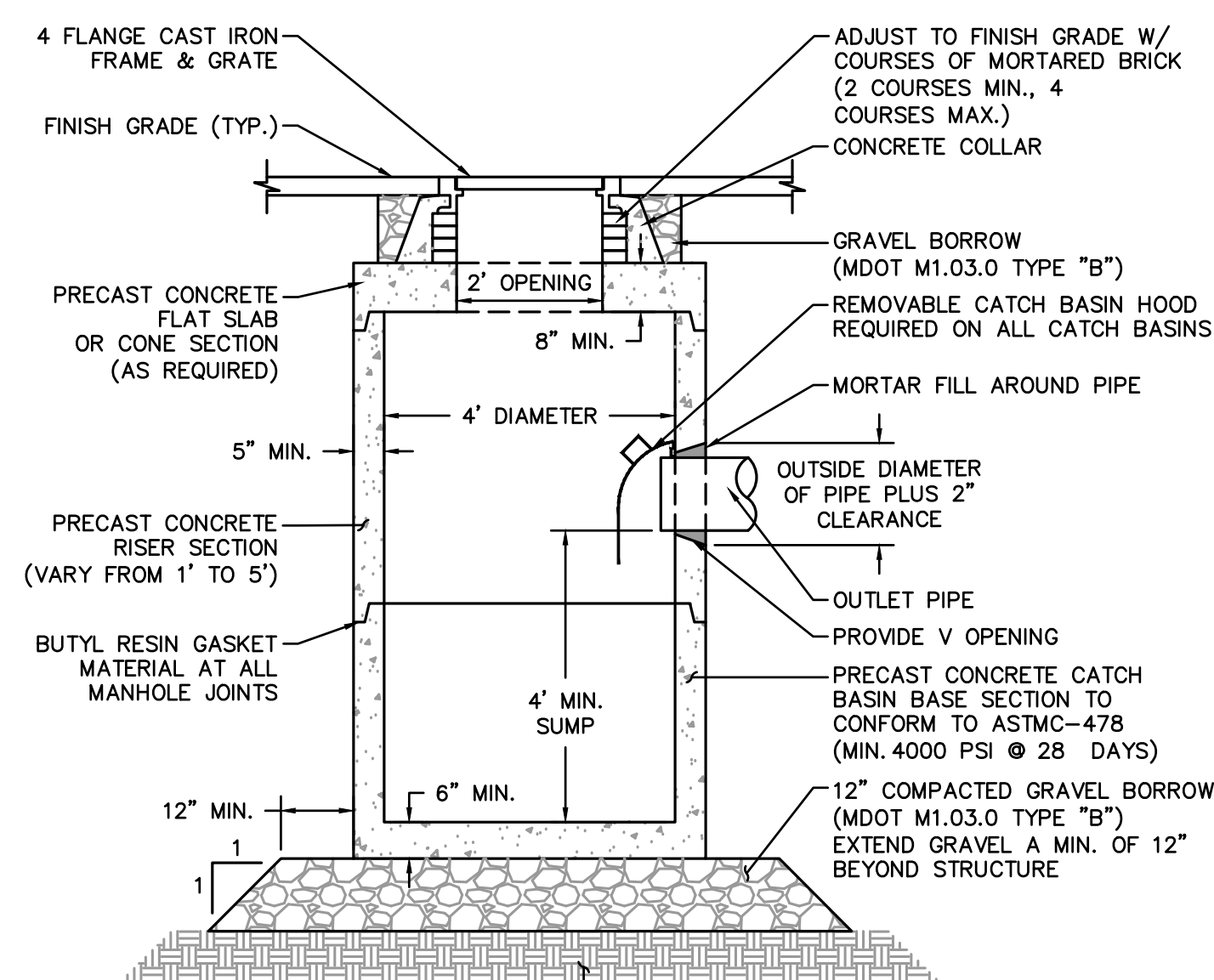

TYPICAL CATCH BASIN DETAIL
NOT TO SCALE

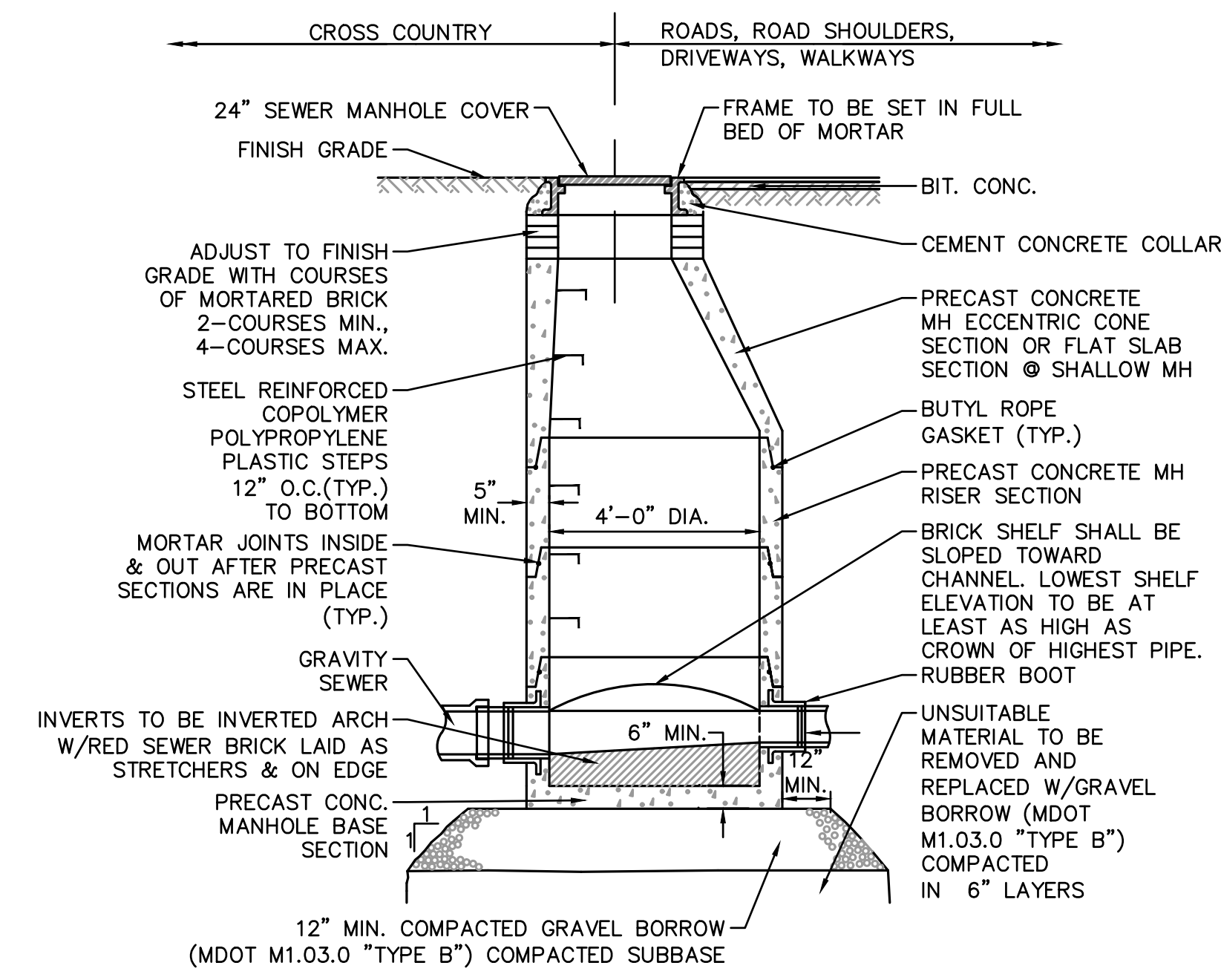

TYPICAL SEWER MANHOLE DETAIL
NOT TO SCALE

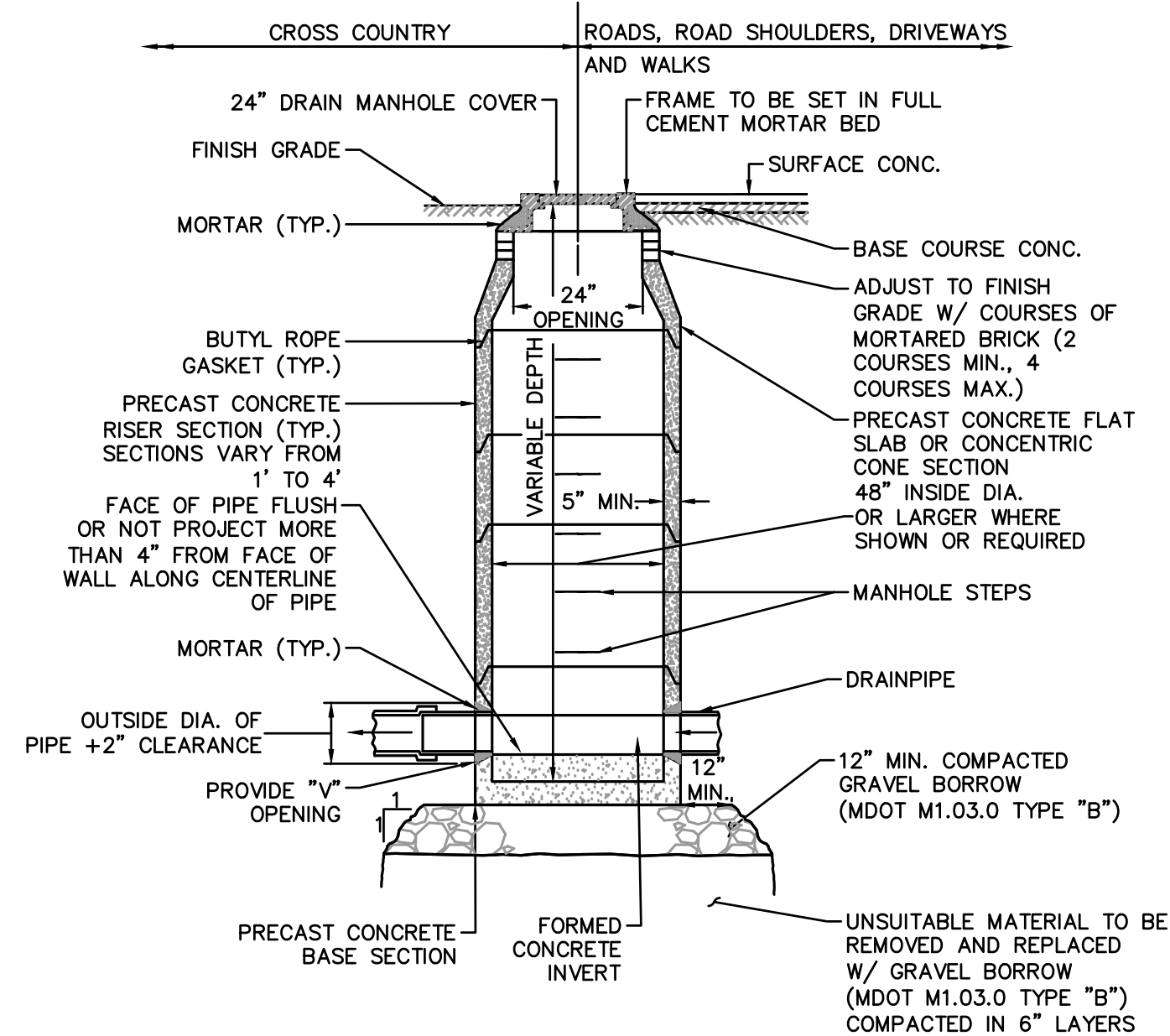

TYPICAL DRAIN MANHOLE DETAIL
NOT TO SCALE

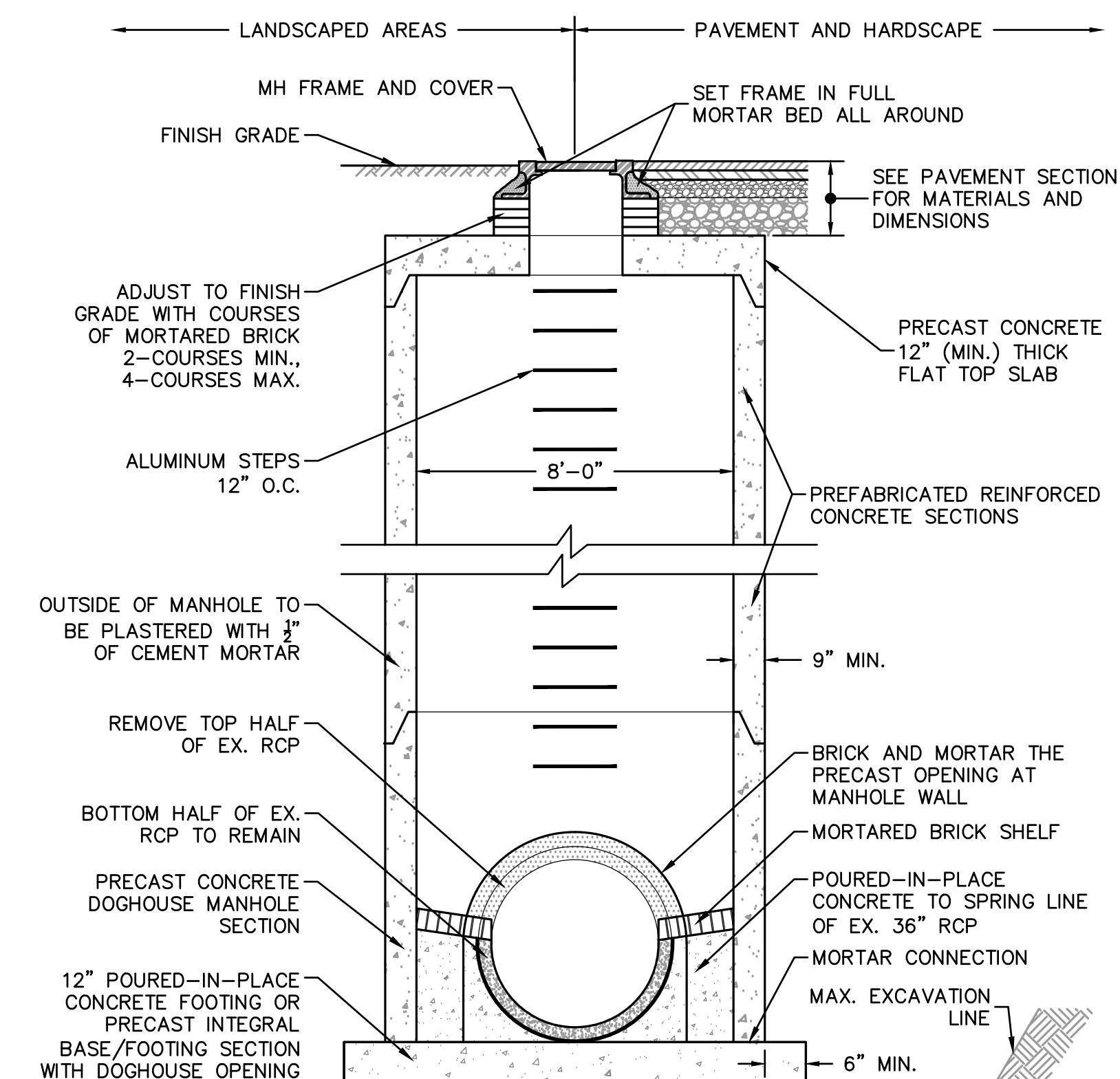

8\"/>

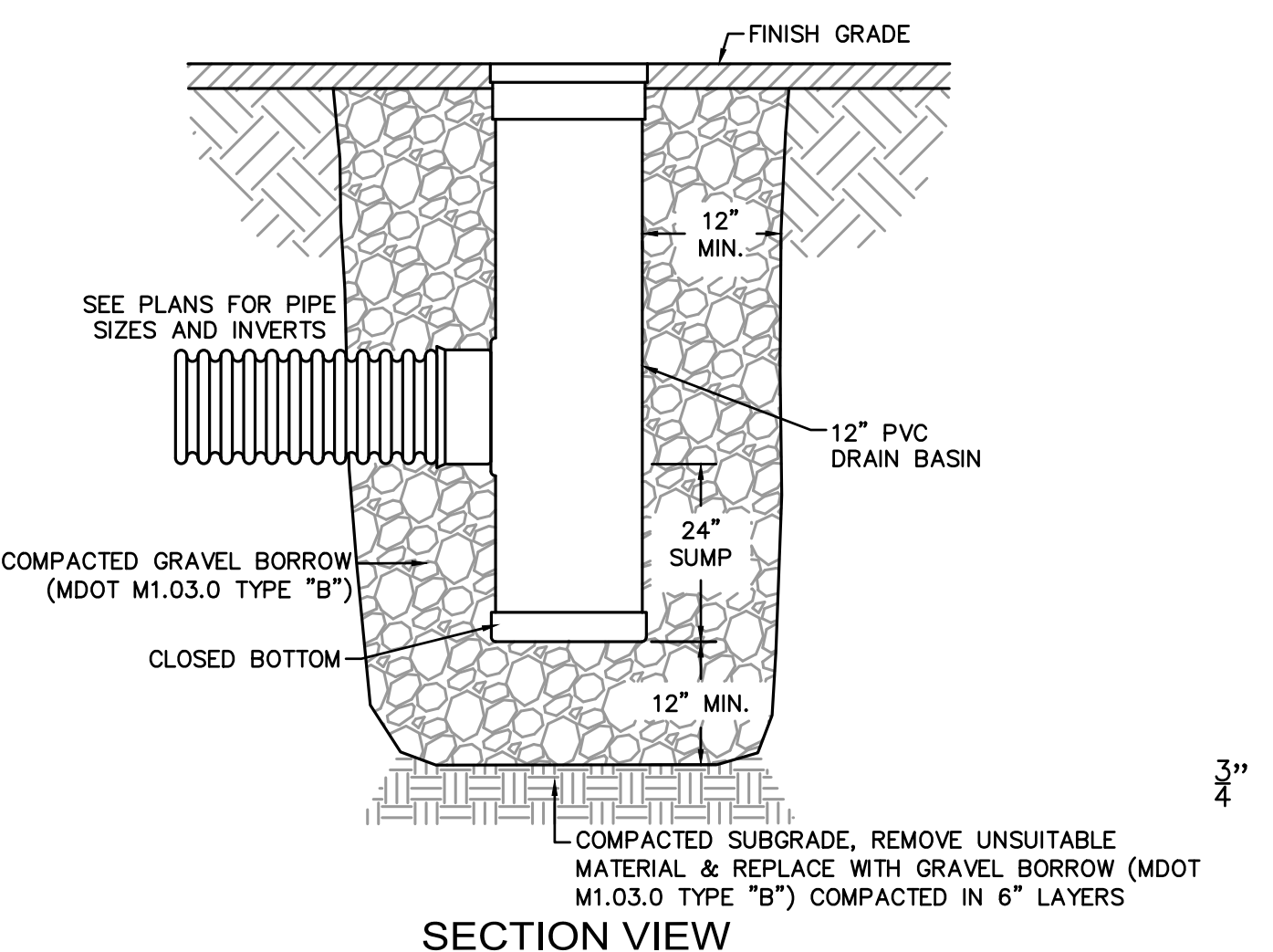

12\"/>

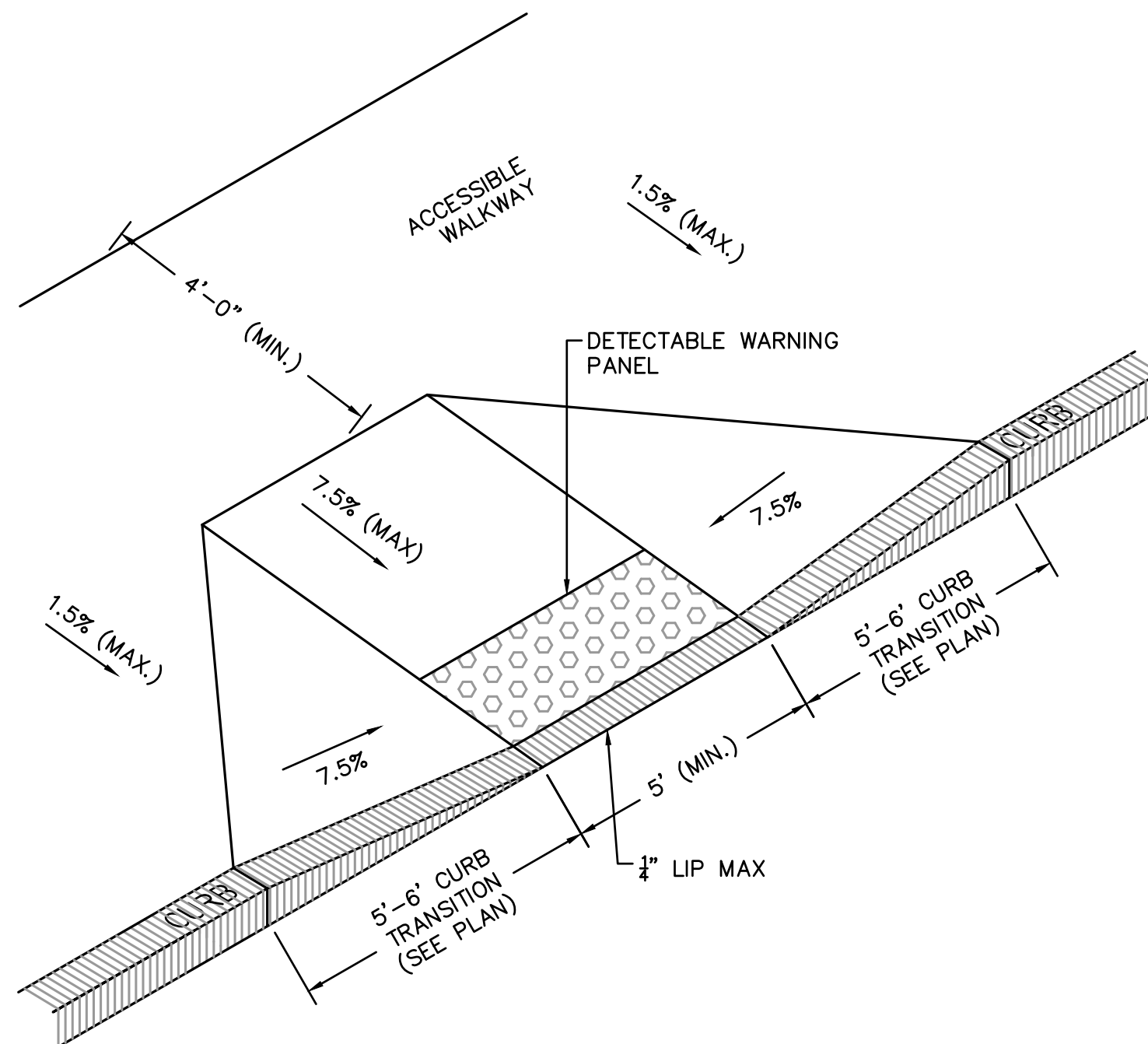

ACCESSIBLE RAMPS WITH GREATER THAN 12'-6\"/>

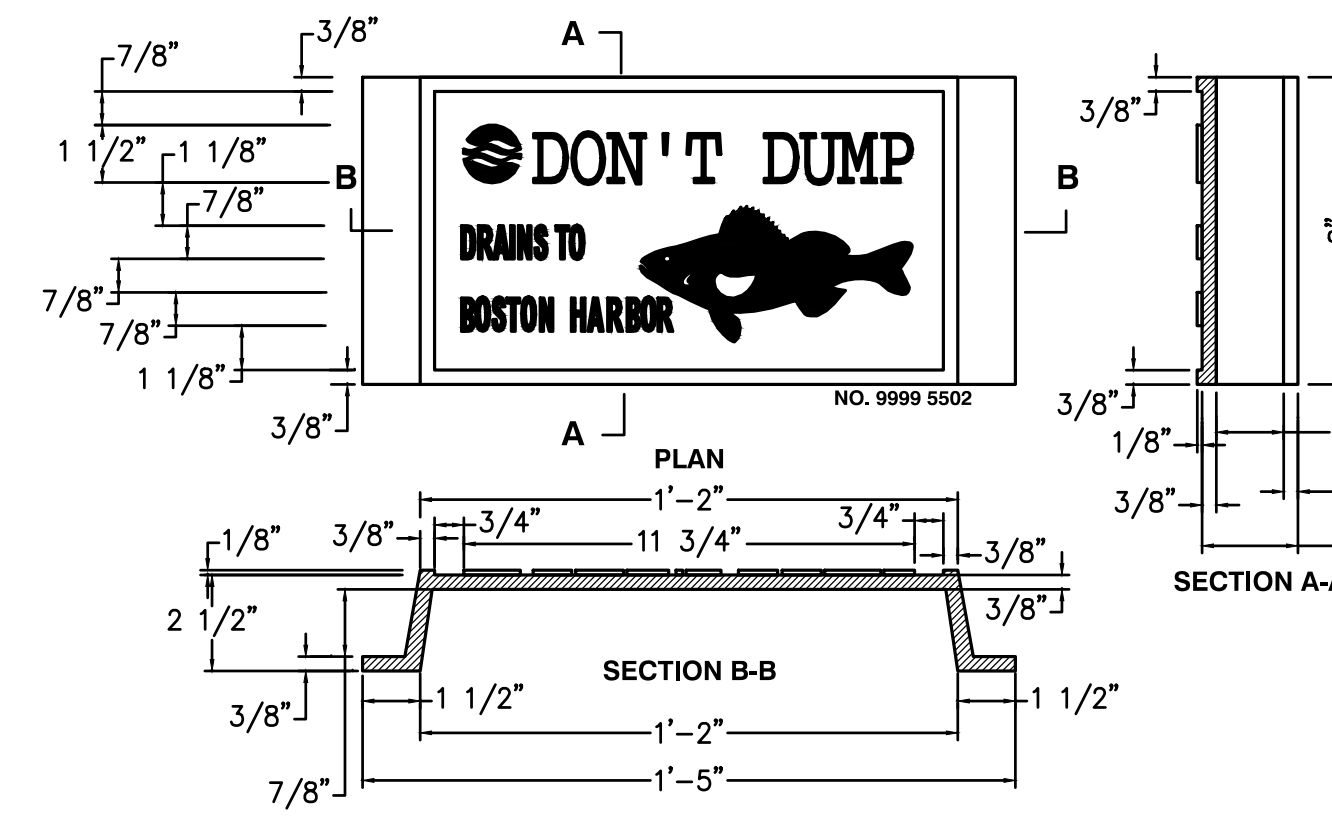

BWSC \"DON'T DUMP\" PLAQUE DETAIL
NOT TO SCALE

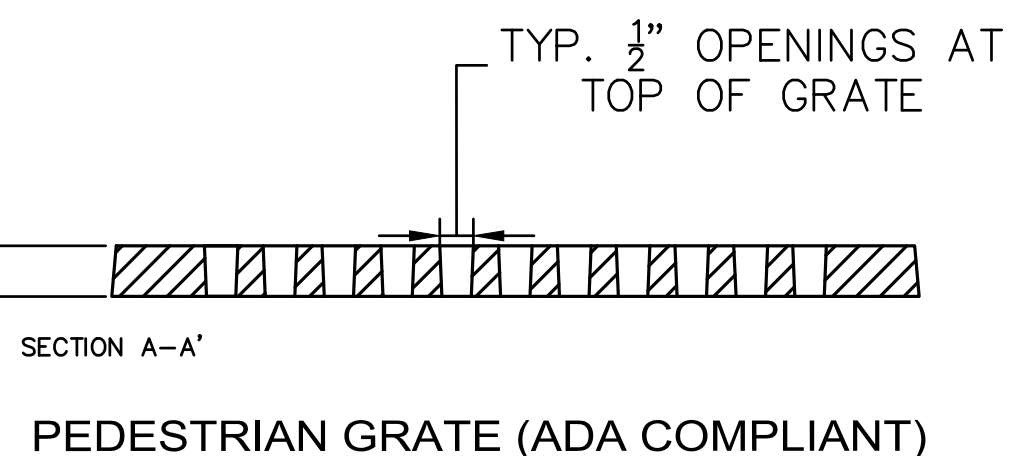
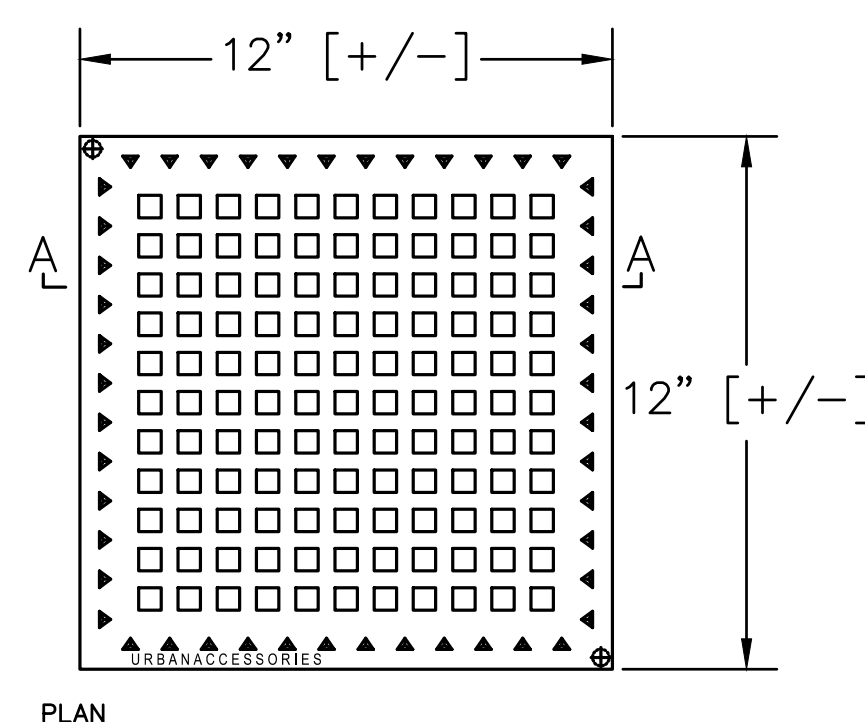

PEDESTRIAN GRATE (ADA COMPLIANT)

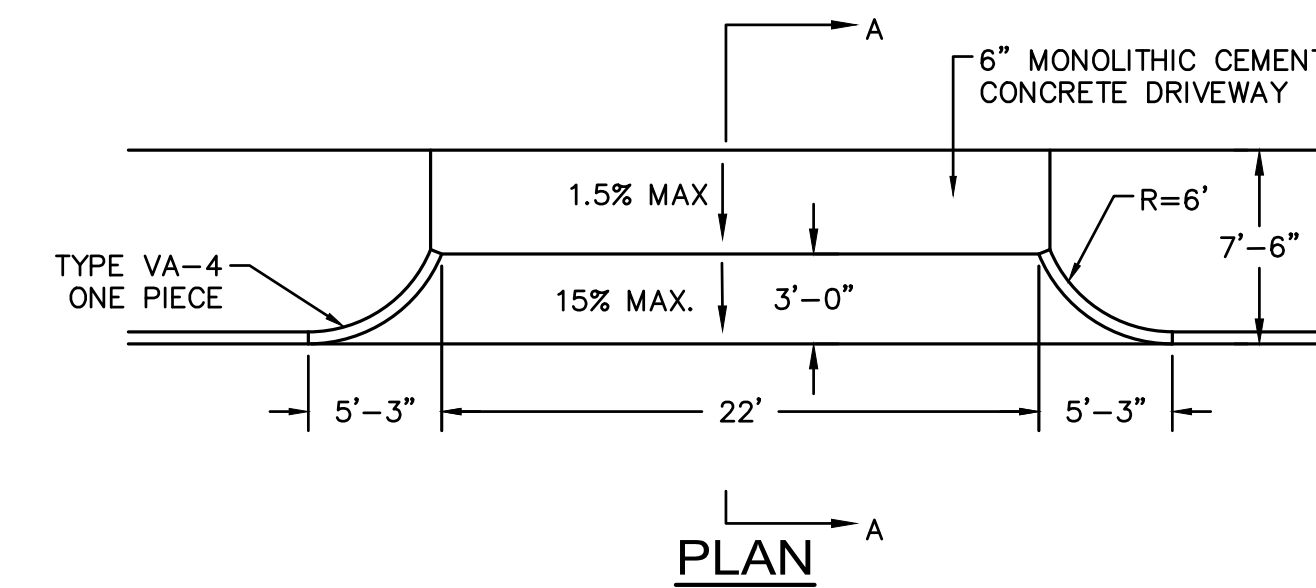

SECTION A-A CONCRETE DRIVEWAY

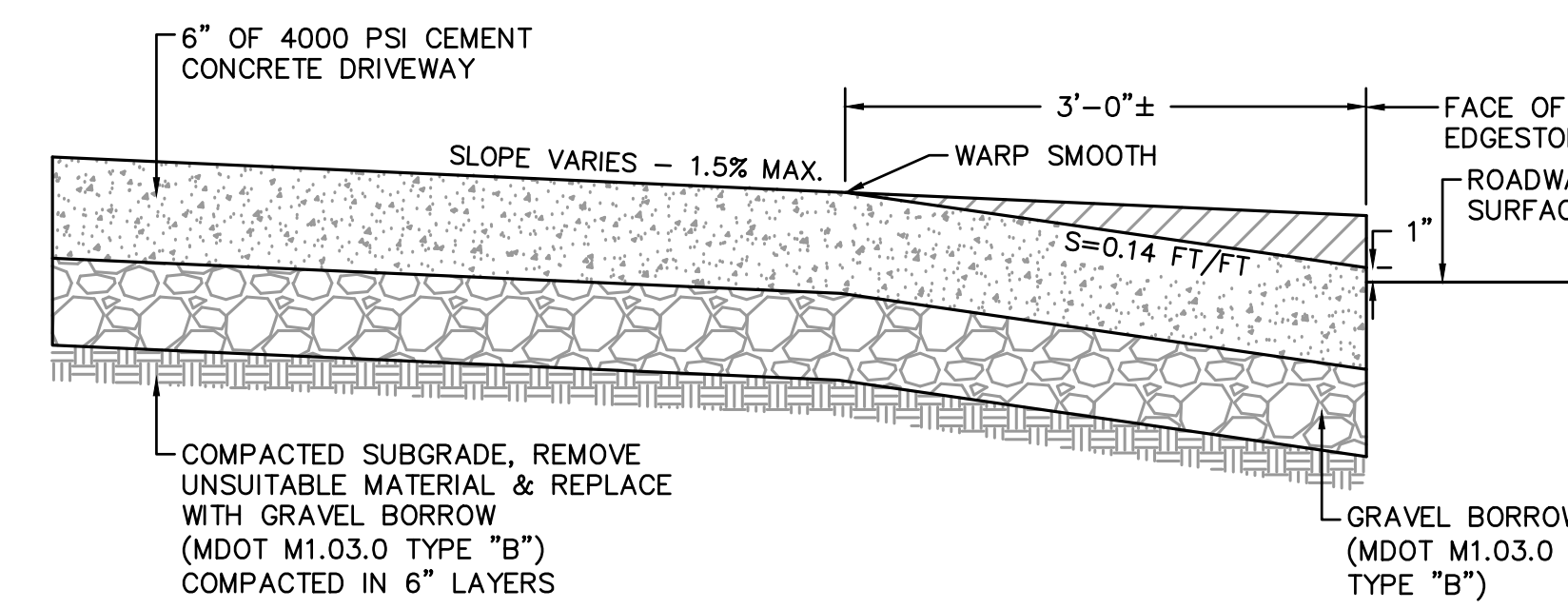

TYPICAL DRIVEWAY-BOSTON STANDARD DETAIL
NOT TO SCALE

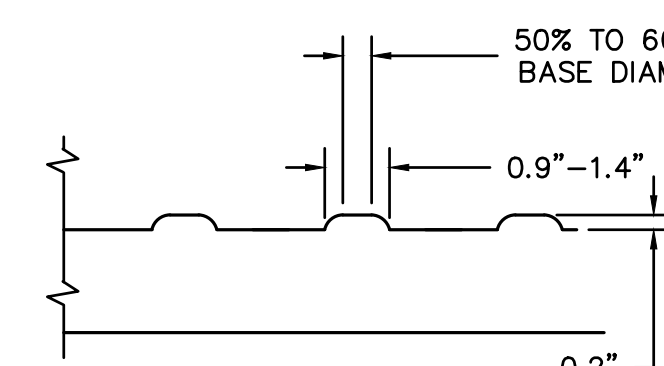

SECTION A-A

NOTES:

1. DETECTABLE WARNING PANELS SHALL BE PERMANENTLY APPLIED TO THE RAMP.
2. DETECTABLE WARNING PANELS SHALL CONTRAST VISUALLY WITH THE ADJACENT WALKWAY SURFACES PER THE FOLLOWING COLOR SCHEDULE:
• PALE YELLOW ON CEMENT CONCRETE PEDESTRIAN RAMPS
3. DETECTABLE WARNING PANELS SHALL BE AS MANUFACTURED BY ADA SOLUTIONS, INC. OF NORTH BILLERICA, MA OR AN APPROVED EQUAL.
4. DETECTABLE WARNING PANELS SHALL BE INSTALLED PER THE MANUFACTURER'S RECOMMENDATIONS.

DETECTABLE WARNING PANEL

DETECTABLE WARNING PANEL FOR PEDESTRIAN RAMPS DETAIL
NOT TO SCALE

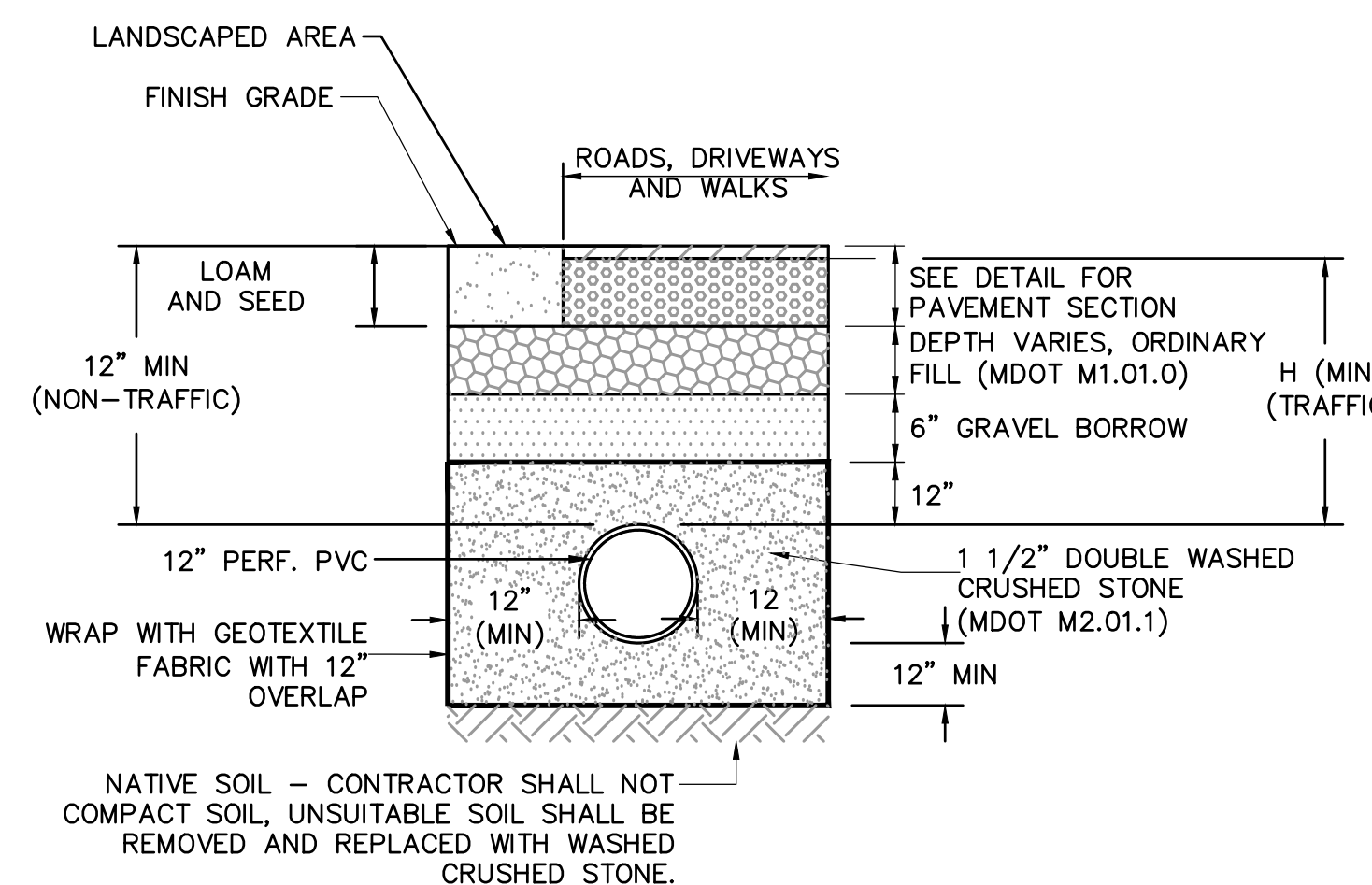

SUBSURFACE SYSTEM 1 INFILTRATION SYSTEM DETAIL
NOT TO SCALE

2 HARBOR

329 NORTHERN AVE
BOSTON, MA 02210

OWNER
BCP-CG HARBOR PROPERTY LLC
C/O BEACON CAPITAL PARTNERS, LLC
200 STATE STREET, FIFTH FLOOR
BOSTON, MA 02109

ARCHITECT
HANDEL ARCHITECTS, LLP
69 CANAL ST., 2ND FLOOR
BOSTON, MA 02114
T: 617.651.4790

CONSULTING ARCHITECT
STUDIO ENÉE
460 HILLSIDE AVE
NEEDHAM, MA 02494
T: 781.858.3011

CONSULTING ARCHITECT
TRIA
21 DRYDOCK AVE, SUITE 330W
BOSTON, MA 02114
T: 617.530.1620

CIVIL ENGINEER
NITSCH ENGINEERING, INC.
2 CENTER PLAZA #430
BOSTON, MA 02108
T: 617.338.0063

MEP ENGINEER & CODE CONSULTANT
COSENTINI ASSOCIATES
101 FEDERAL ST #600
BOSTON, MA 02110
T: 617.748.7800

STRUCTURAL ENGINEER
DESIMONE CONSULTING ENGINEERS
31 MILK ST., SUITE 1016
BOSTON, MA 02109
T: 617.836.4492

LANDSCAPE ARCHITECT
KLOPFER MARTIN DESIGN GROUP
69 CANAL ST., 2ND FLOOR
BOSTON, MA 02114
T: 617.227.2560

ENVELOPE CONSULTANT
CBI CONSULTING, LLC
250 DORCHESTER AVE
BOSTON, MA 02127
T: 617.268.8977

GEOTECHNICAL
HALEY & ALDRICH, INC.
465 MEDFORD ST., SUITE 2200
BOSTON, MA 02129
T: 617.886.7400

NOT FOR CONSTRUCTION

NO.	DATE	ISSUANCE
1	12/20/2019	CONCEPT PRICING
2	12/15/2020	50% SCHEMATIC DESIGN
3	2/18/2021	100% SCHEMATIC DESIGN
4	4/16/2021	EARLY SITE PACKAGE

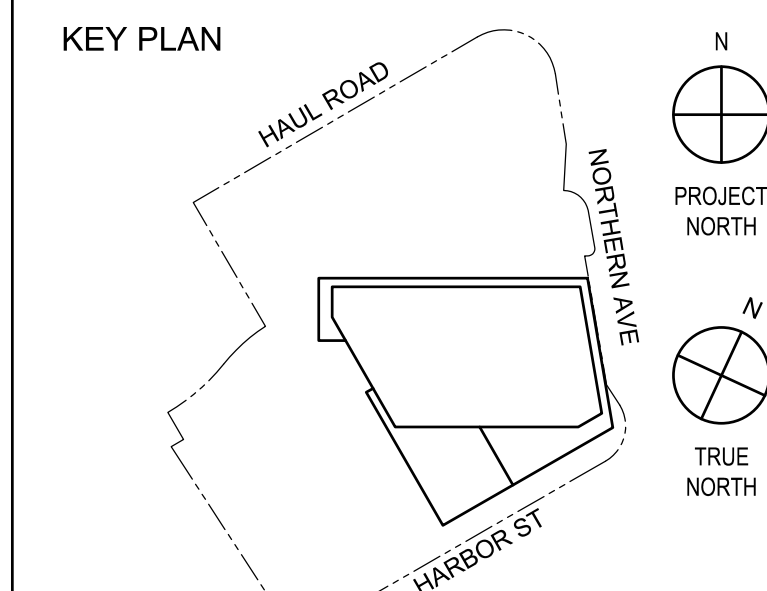

PROJECT DATUM: PROJ. 0'-0" = +16'-5" BCB
SCALE: AS NOTED
PROJECT NO: 1550
SEAL & SIGNATURE

DRAWING TITLE:

DETAILS I

DRAWING NO:

C-500

2 HARBOR

329 NORTHERN AVE
BOSTON, MA 02210

OWNER
BCP-CG HARBOR PROPERTY LLC
C/O BEACON CAPITAL PARTNERS, LLC
200 STATE STREET, FIFTH FLOOR
BOSTON, MA 02109

ARCHITECT
HANDEL ARCHITECTS, LLP
69 CANAL ST, 2ND FLOOR
BOSTON, MA 02114
T: 617.651.4790

CONSULTING ARCHITECT
STUDIO ENÉE
460 HILLSIDE AVE
NEEDHAM, MA 02494
T: 781.858.3011

CONSULTING ARCHITECT
TRIA
21 DRYDOCK AVE, SUITE 330W
BOSTON, MA 02210
T: 617.530.1620

CIVIL ENGINEER
NITSCH ENGINEERING, INC.
2 CENTER PLAZA #430
BOSTON, MA 02108
T: 617.338.0063

MEP ENGINEER & CODE CONSULTANT
COSENTINI ASSOCIATES
101 FEDERAL ST #600
BOSTON, MA 02110
T: 617.748.7800

STRUCTURAL ENGINEER
DESIMONE CONSULTING ENGINEERS
31 MILK ST, SUITE 1016
BOSTON, MA 02109
T: 617.836.4492

LANDSCAPE ARCHITECT
KLOPFER MARTIN DESIGN GROUP
69 CANAL ST, 2ND FLOOR
BOSTON, MA 02114
T: 617.227.2560

ENVELOPE CONSULTANT
CBI CONSULTING, LLC
250 DORCHESTER AVE
BOSTON, MA 02127
T: 617.268.8977

GEOTECHNICAL
HALEY & ALDRICH, INC.
485 MEDFORD ST, SUITE 2200
BOSTON, MA 02129
T: 617.886.7400

NOT FOR CONSTRUCTION

NO.	DATE	ISSUANCE
1	12/20/2019	CONCEPT PRICING
2	12/15/2020	50% SCHEMATIC DESIGN
3	2/18/2021	100% SCHEMATIC DESIGN
4	4/16/2021	EARLY SITE PACKAGE

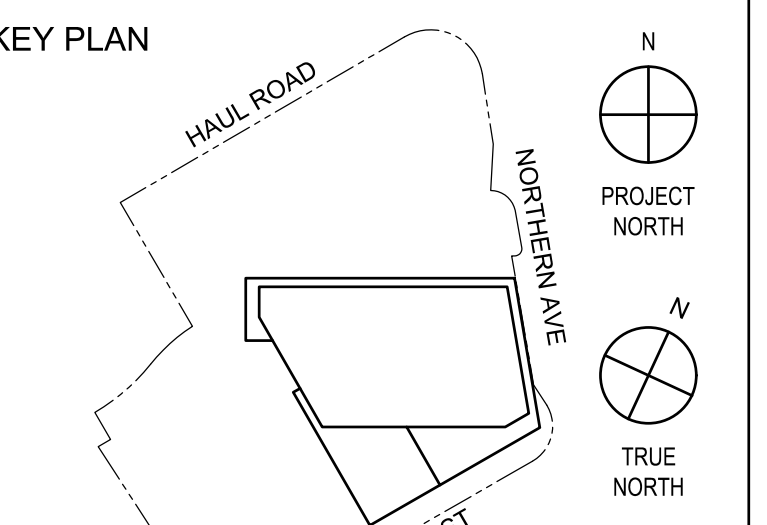

PROJECT DATUM: PROJ. 0'-0" = +16'-6" BCB
SCALE: AS NOTED
PROJECT NO: 1550
SEAL & SIGNATURE

DRAWING TITLE:
DETAILS II

DRAWING NO:
C-501

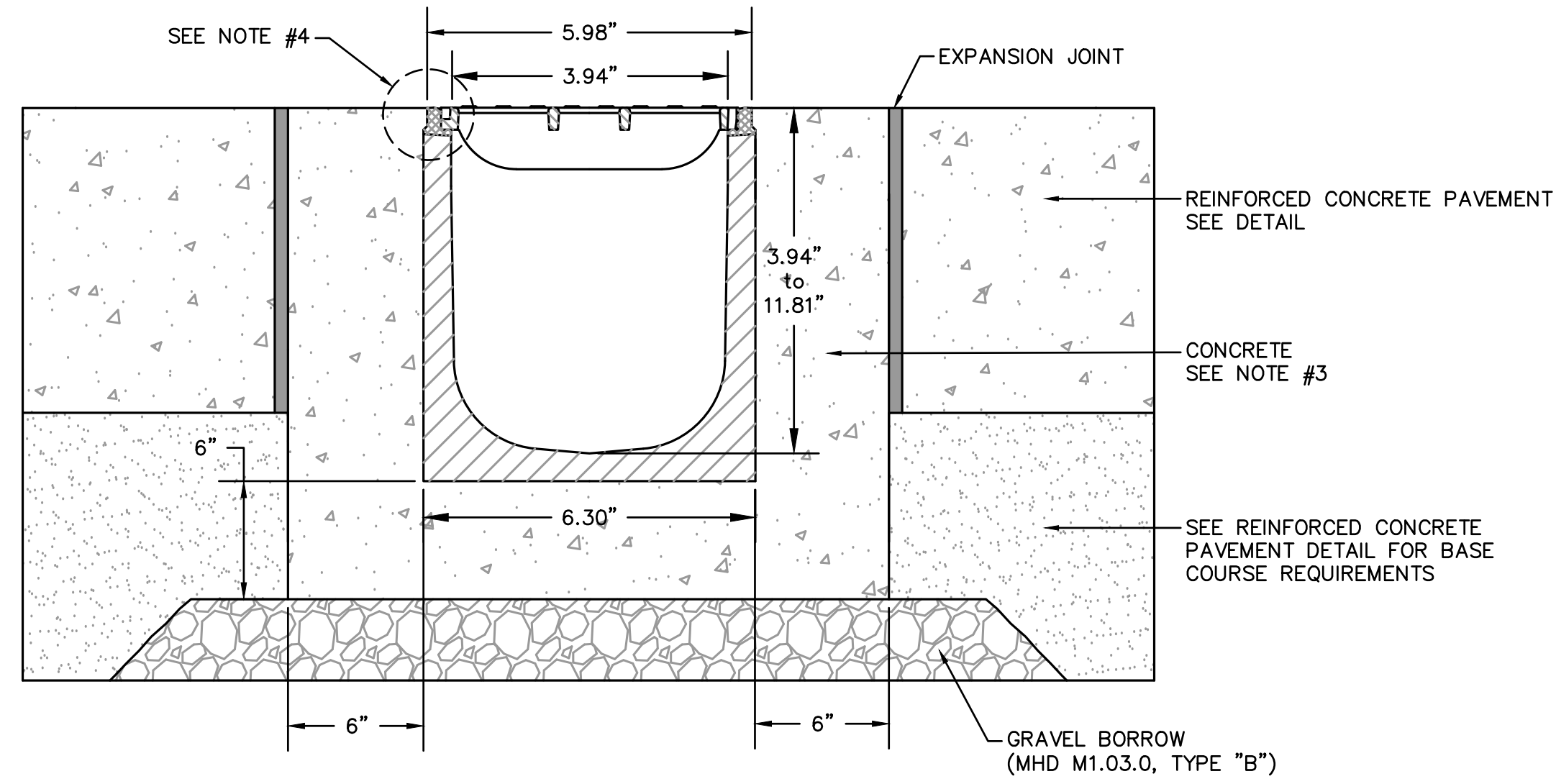

- NOTES:
- TRENCH DRAIN SHALL BE A POLYMER CONCRETE CHANNEL SYSTEM WITH A DUCTILE IRON RAIL AND GRATE.
 - TRENCH DRAIN SYSTEM AND GRATES SHALL BE H-20 LOADING.
 - CONCRETE CRADLE FOR TRENCH DRAIN SHALL BE MINIMUM 4,000 PSI. CONCRETE SHALL BE VIBRATED TO ELIMINATE AIR POCKETS.
 - THE FINISHED LEVEL OF THE SURROUNDING CONCRETE SHALL BE SET 1/8" ABOVE THE TOP OF THE CHANNEL EDGE.
 - TRENCH DRAIN GRATE SHALL BE ADA COMPLIANT.
 - TRENCH DRAIN SYSTEM SHALL BE INSTALLED PER MANUFACTURER'S RECOMMENDATIONS.
 - ALL TRENCH DRAINS SHALL BE PROVIDED WITH AN INLINE CATCH BASIN AT THE LOW POINT OF THE SYSTEM. WIDTH OF INLINE CATCH BASIN TO MATCH WIDTH OF TRENCH DRAIN.

4" TRENCH DRAIN IN CONCRETE PAVEMENT DETAIL
NOT TO SCALE

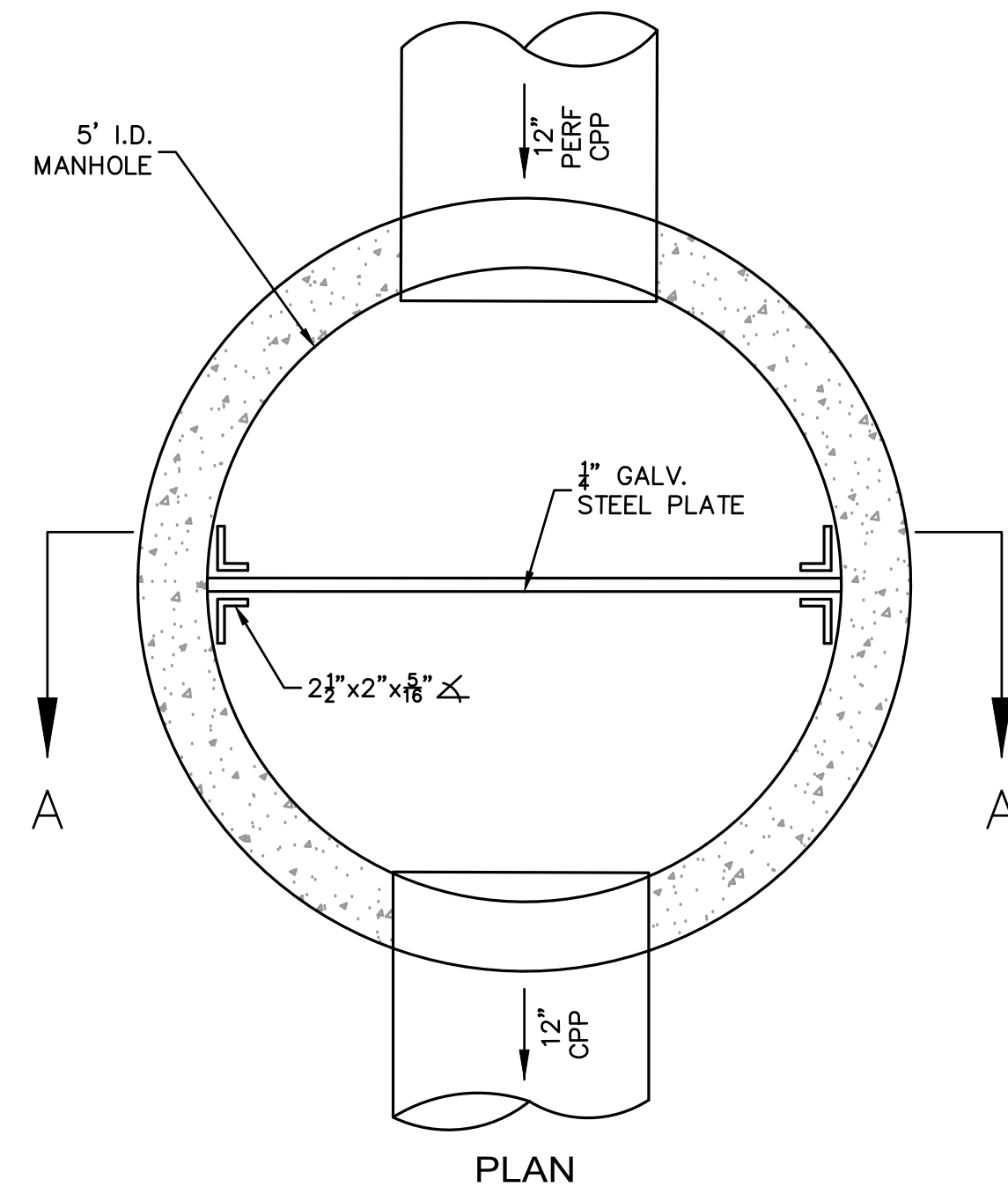

OUTLET CONTROL STRUCTURE (OCS700)
NOT TO SCALE

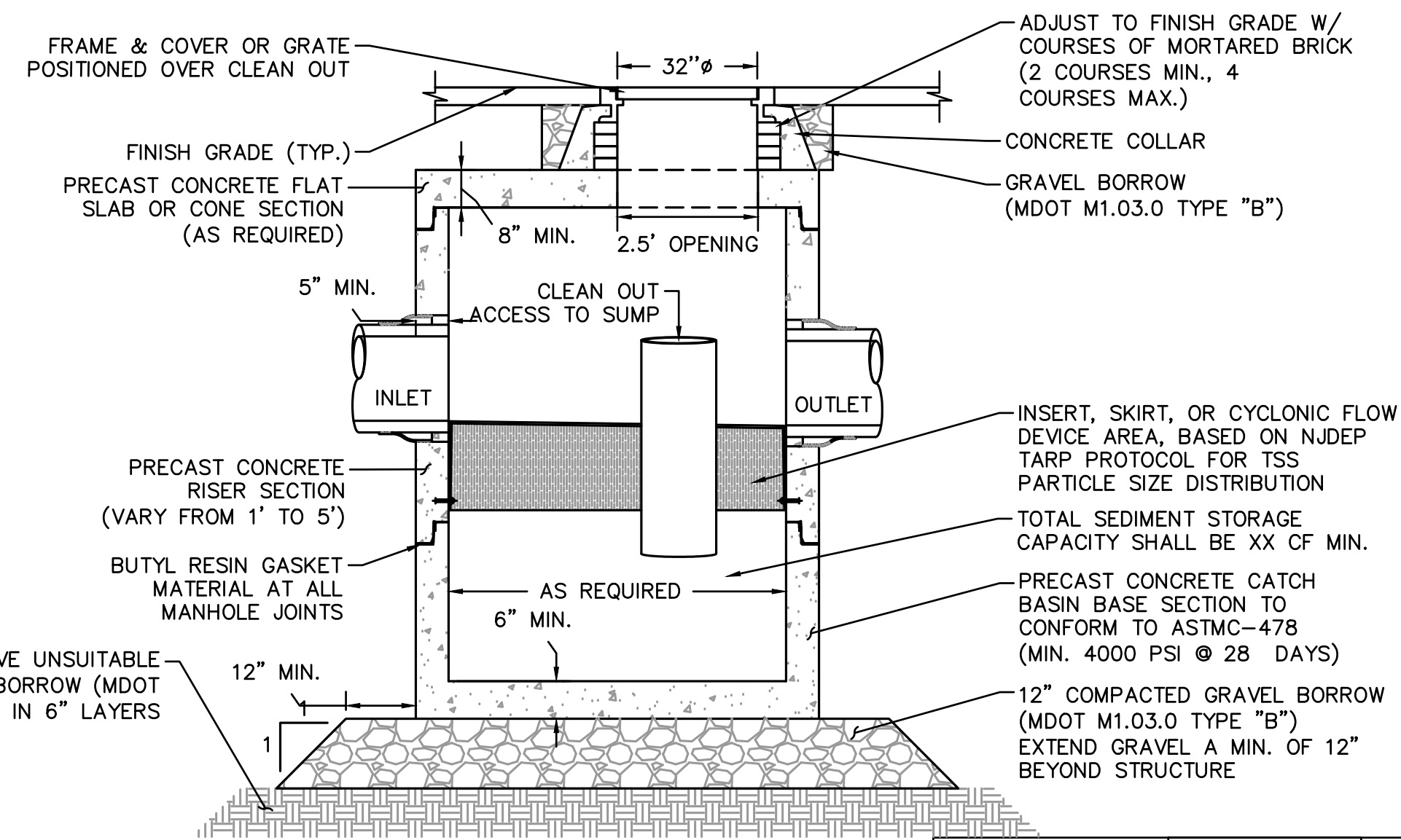
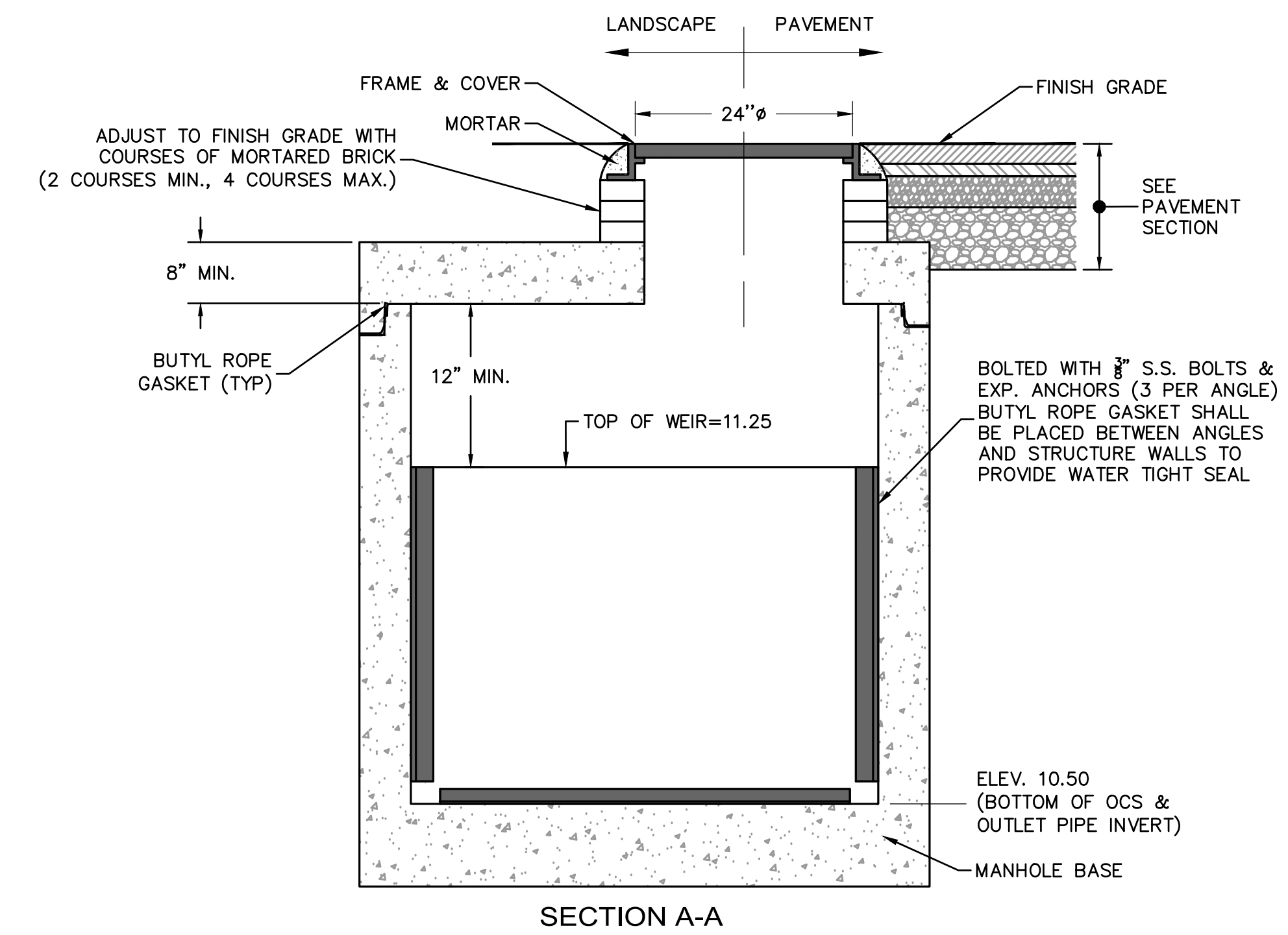

- NOTE:
- THE USE OF FLEXIBLE CONNECTIONS IS RECOMMENDED AT THE INLET AND OUTLET WHERE APPLICABLE.
 - THE COVER SHOULD BE POSITIONED OVER THE OUTLET DROP PIPE AND THE OIL CLEANOUT PIPE.
 - STRUCTURE DESIGNED FOR H2O LOADING

WATER QUALITY STRUCTURE DETAIL
NOT TO SCALE

STRUCTURE NAME	MINIMUM WQF	PEAK FLOW RATE*	MINIMUM SEDIMENT STORAGE CAPACITY
WQ500	0.70 CFS	X.XX CFS	12 CF
WQ501	1.91 CFS	X.XX CFS	33 CF

* PEAK FLOW RATE BASED ON RATIONAL ANALYSIS FOR A 25-YEAR STORM EVENT. STRUCTURE SHALL BE ABLE TO PASS PEAK FLOW RATE WITHOUT CAUSING A BACKWATER CONDITION.

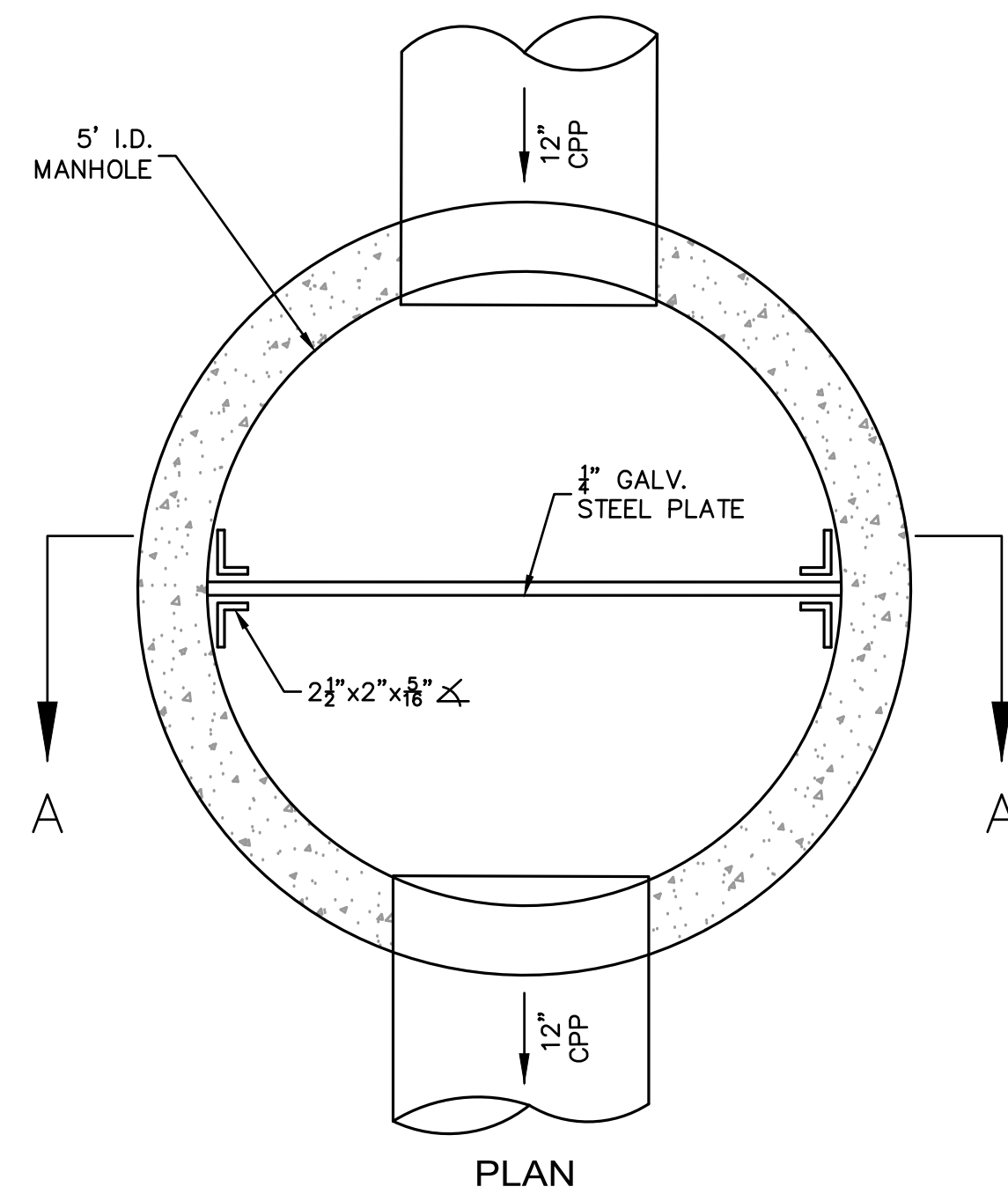

OUTLET CONTROL STRUCTURE (OCS701)
NOT TO SCALE

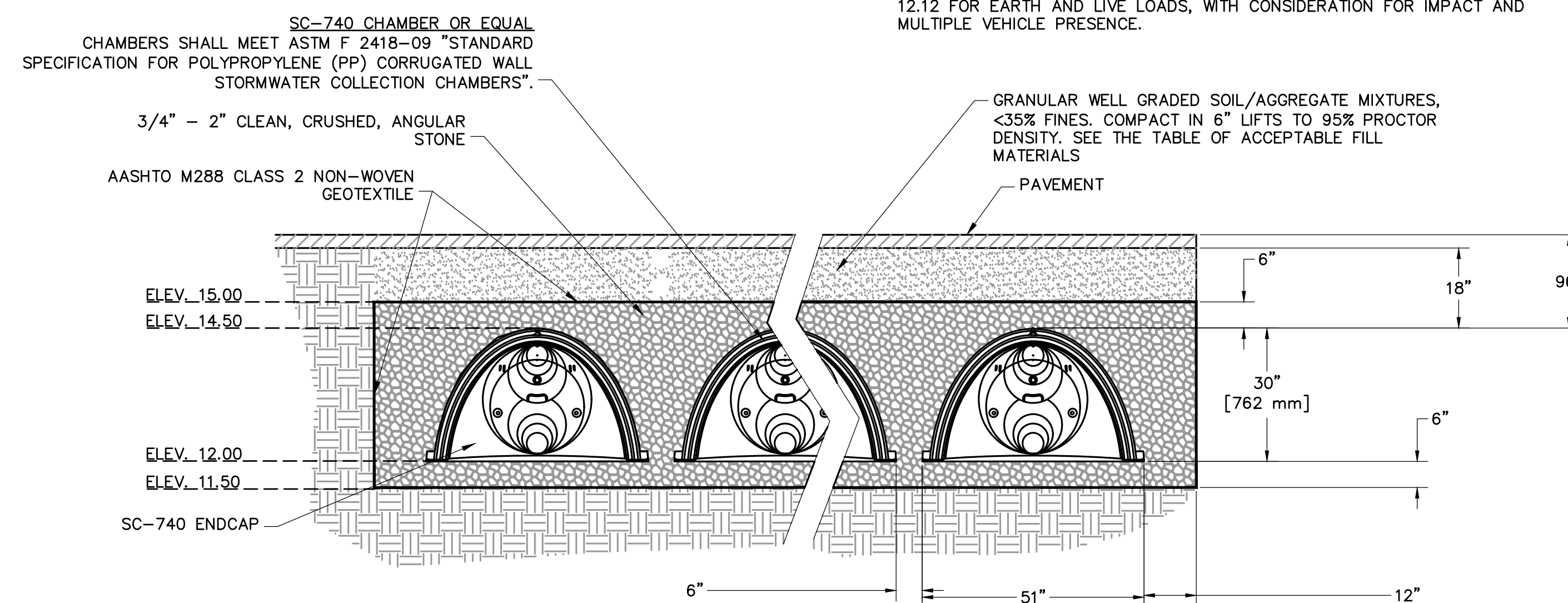
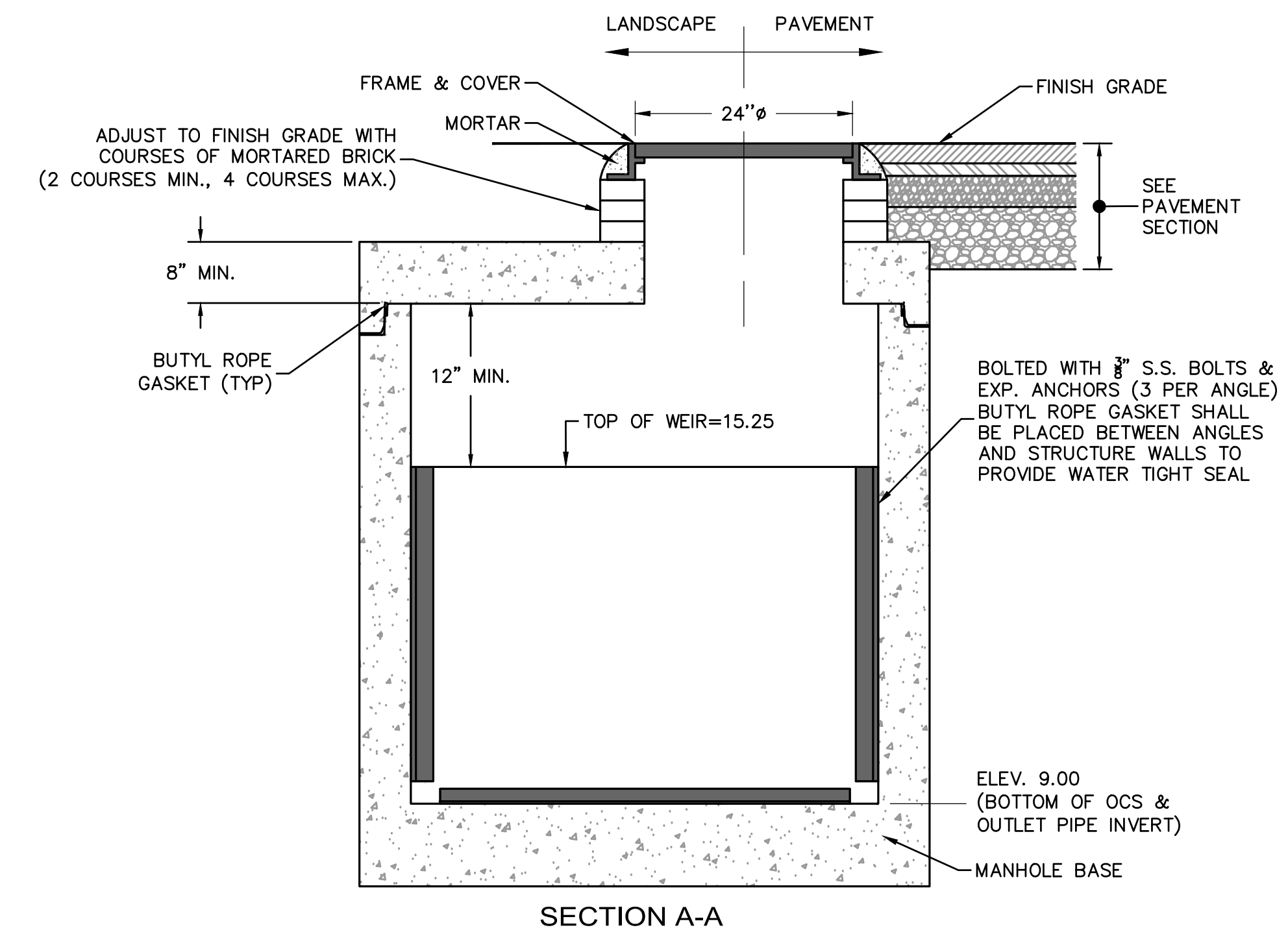

SUBSURFACE SYSTEM 2A AND 2B INFILTRATION SYSTEM DETAIL
NOT TO SCALE

Appendix A

Calculations



CALCULATIONS

0200427-000

1 of 4

Client:	BCP-CG Harbor Property LLC	15-Apr-21
Project:	2 Harbor Street/ 329 Northern Avenue	SHL
Subject:	Stormwater Storage and Infiltration Systems	MDK

PROBLEM STATEMENT & OBJECTIVE

To evaluate the following related to the proposed stormwater infiltration at the Subject property:

- a) Evaluate the mounding potential for the subject project's stormwater storage and infiltration systems as it relates to complying with the requirement to retain and infiltrate the design storm volume within 72-hours.
- b) Three total systems are evaluated in this analysis: System 1 (14,500 CF), System 2A (2,500 CF), and System 2B (1,800 CF) for a total volume of 18,800 CF.

REFERENCES

1. Massachusetts Stormwater Guidance.
2. Discroll (1986), Groundwater and Wells.
3. Hantush, M.S., 1967, Growth and decay of groundwater mounds in response to uniform percolation: Water Resources Research, v. 3, p. 227–234.

ASSUMPTIONS

1. Ground surface elevation is El. 16.0 BCB (Boston City Base)
2. Seasonal high groundwater elevation is El. 8.0 BCB
3. Fill thickness is 20 feet below ground surface. The fill is predominately SAND.
4. The Rawl's Rate for SAND (8.3 inches/hour) is used in the mounding analysis with a 1/2 factor of safety applied for an estimated hydraulic conductivity of 4.1 inches/hour or 8.2 feet/day

SYSTEM 1:

1. The proposed infiltration volume for System 1 is 14,500 CF over a period of 72-hours.
2. For this analysis, System 1 is assumed to consist of a 358' x 10' linear drainage gallery.
3. Estimated maximum groundwater mounding for System 1 after 72-hours is 3.1 feet above static water level, or El. 11.1 BCB
4. The Hantush (1967) solution result for System 1 is located on **Page 2**.

SYSTEM 2A:

1. The proposed infiltration volume for System 2A is 2,500 CF over a period of 72-hours.
2. For this analysis, System 2A is assumed to consist of a 54' x 26' open-bottomed infiltration system.
3. Estimated maximum groundwater mounding for System 2A after 72-hours is 2.0 feet above static water level, or El. 10.0 BCB
4. The Hantush (1967) solution result for System 2A is located on **Page 3**.

SYSTEM 2B:

1. The proposed infiltration volume for System 2B is 1,800 CF over a period of 72-hours.
2. For this analysis, System 2A is assumed to consist of a 40' x 26' open-bottomed infiltration system.
3. Estimated maximum groundwater mounding for System 2B after 72-hours is 1.6 feet above static water level, or El. 9.6 BCB
4. The Hantush (1967) solution result for System 2A is located on **Page 4**.

Client:	BCP-CG Harbor Property LLC	15-Apr-21
Project:	2 Harbor Street/ 329 Northern Avenue	SHL
Subject:	Stormwater Storage and Infiltration Systems: System 1	MDK

SYSTEM 1 HANTUSH (1967) SOLUTION RESULTS

This spreadsheet will calculate the height of a groundwater mound beneath a stormwater infiltration basin. More information can be found in the U.S. Geological Survey Scientific Investigations Report 2010-5102 "Simulation of groundwater mounding beneath hypothetical stormwater infiltration basins".

The user must specify infiltration rate (R), specific yield (Sy), horizontal hydraulic conductivity (Kh), basin dimensions (x, y), duration of infiltration period (t), and the initial thickness of the saturated zone (hi(0), height of the water table if the bottom of the aquifer is the datum). For a square basin the half width equals the half length (x = y). For a rectangular basin, if the user wants the water-table changes perpendicular to the long side, specify x as the short dimension and y as the long dimension. Conversely, if the user wants the values perpendicular to the short side, specify y as the short dimension, x as the long dimension. All distances are from the center of the basin. Users can change the distances from the center of the basin at which water-table aquifer thickness are calculated.

Cells highlighted in yellow are values that can be changed by the user. Cells highlighted in red are output values based on user-specified inputs. The user **MUST** click the blue "Re-Calculate Now" button each time ANY of the user-specified inputs are changed otherwise necessary iterations to converge on the correct solution will not be done and values shown will be incorrect. Use consistent units for all input values (for example, feet and days)

Input Values		use consistent units (e.g. feet & days or inches & hours)	Conversion Table	
1.3500	R	Recharge (infiltration) rate (feet/day)	inch/hour	feet/day
0.150	Sy	Specific yield, Sy (dimensionless, between 0 and 1)	0.67	1.33
8.25	K	Horizontal hydraulic conductivity, Kh (feet/day)*	2.00	4.00
179.000	x	1/2 length of basin (x direction, in feet)	hours	days
5.000	y	1/2 width of basin (y direction, in feet)	36	1.50
3.000	t	duration of infiltration period (days)		
12.000	hi(0)	initial thickness of saturated zone (feet)		
15.073	h(max)	maximum thickness of saturated zone (beneath center of basin at end of infiltration period)		
3.073	Δh(max)	maximum groundwater mounding (beneath center of basin at end of infiltration period)		
Ground-water Mounding, in feet	Distance from center of basin in x direction, in feet			

In the report accompanying this spreadsheet (USGS SIR 2010-5102), vertical soil permeability (ft/d) is assumed to be one-tenth horizontal hydraulic conductivity (ft/d).

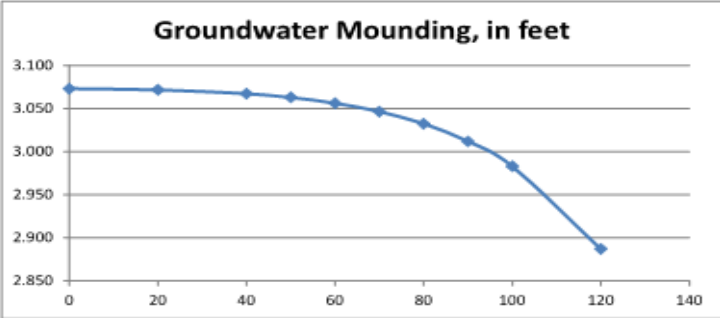

Disclaimer

This spreadsheet solving the Hantush (1967) equation for ground-water mounding beneath an infiltration basin is made available to the general public as a convenience for those wishing to replicate values documented in the USGS Scientific Investigations Report 2010-5102 "Groundwater mounding beneath hypothetical stormwater infiltration basins" or to calculate values based on user-specified site conditions. Any changes made to the spreadsheet (other than values identified as user-specified) after transmission from the USGS could have unintended, undesirable consequences. These consequences could include, but may not be limited to: erroneous output, numerical instabilities, and violations of underlying assumptions that are inherent in results presented in the accompanying USGS published report. The USGS assumes no responsibility for the consequences of any changes made to the spreadsheet. If changes are made to the spreadsheet, the user is responsible for documenting the changes and justifying the results and conclusions.

Client:	BCP-CG Harbor Property LLC	15-Apr-21
Project:	2 Harbor Street/ 329 Northern Avenue	SHL
Subject:	Stormwater Storage and Infiltration Systems: System 2A	MDK

SYSTEM 2A HANTUSH (1967) SOLUTION RESULTS

This spreadsheet will calculate the height of a groundwater mound beneath a stormwater infiltration basin. More information can be found in the U.S. Geological Survey Scientific Investigations Report 2010-5102 "Simulation of groundwater mounding beneath hypothetical stormwater infiltration basins".

The user must specify infiltration rate (R), specific yield (Sy), horizontal hydraulic conductivity (Kh), basin dimensions (x, y), duration of infiltration period (t), and the initial thickness of the saturated zone (hi(0), height of the water table if the bottom of the aquifer is the datum). For a square basin the half width equals the half length (x = y). For a rectangular basin, if the user wants the water-table changes perpendicular to the long side, specify x as the short dimension and y as the long dimension. Conversely, if the user wants the values perpendicular to the short side, specify y as the short dimension, x as the long dimension. All distances are from the center of the basin. Users can change the distances from the center of the basin at which water-table aquifer thickness are calculated.

Cells highlighted in yellow are values that can be changed by the user. Cells highlighted in red are output values based on user-specified inputs. The user MUST click the blue "Re-Calculate Now" button each time ANY of the user-specified inputs are changed otherwise necessary iterations to converge on the correct solution will not be done and values shown will be incorrect. Use consistent units for all input values (for example, feet and days)

use consistent units (e.g. feet & days or inches & hours)

Input Values

0.5950
0.150
8.25
27.000
13.000
3.000
12.000

R
Sy
K
x
y
t
hi(0)

Recharge (infiltration) rate (feet/day)
Specific yield, Sy (dimensionless, between 0 and 1)
Horizontal hydraulic conductivity, Kh (feet/day)*
1/2 length of basin (x direction, in feet)
1/2 width of basin (y direction, in feet)
duration of infiltration period (days)
initial thickness of saturated zone (feet)

Conversion Table

inch/hour	feet/day
0.67	1.33
2.00	4.00
hours	days
36	1.50

In the report accompanying this spreadsheet (USGS SIR 2010-5102), vertical soil permeability (ft/d) is assumed to be one-tenth horizontal hydraulic conductivity (ft/d).

14.009
2.009

h(max)
Δh(max)

maximum thickness of saturated zone (beneath center of basin at end of infiltration period)
maximum groundwater mounding (beneath center of basin at end of infiltration period)

Ground-water Mounding, in feet	Distance from center of basin in x direction, in feet
--------------------------------	---

2.009	0
1.710	20
0.905	40
0.650	50
0.468	60
0.335	70
0.238	80
0.167	90
0.116	100
0.055	120



Re-Calculate Now

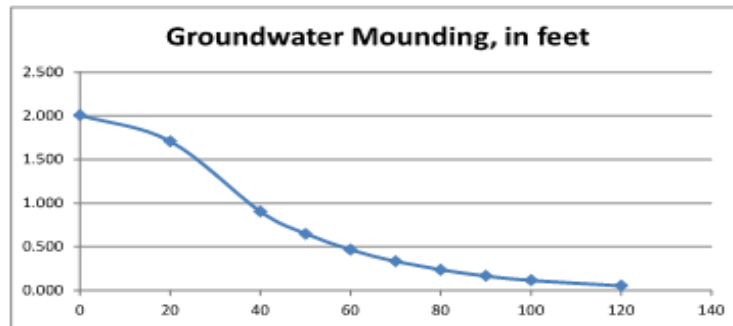

Disclaimer

This spreadsheet solving the Hantush (1967) equation for ground-water mounding beneath an infiltration basin is made available to the general public as a convenience for those wishing to replicate values documented in the USGS Scientific Investigations Report 2010-5102 "Groundwater mounding beneath hypothetical stormwater infiltration basins" or to calculate values based on user-specified site conditions. Any changes made to the spreadsheet (other than values identified as user-specified) after transmission from the USGS could have unintended, undesirable consequences. These consequences could include, but may not be limited to: erroneous output, numerical instabilities, and violations of underlying assumptions that are inherent in results presented in the accompanying USGS published report. The USGS assumes no responsibility for the consequences of any changes made to the spreadsheet. If changes are made to the spreadsheet, the user is responsible for documenting the changes and justifying the results and conclusions.

Client:	BCP-CG Harbor Property LLC	15-Apr-21
Project:	2 Harbor Street/ 329 Northern Avenue	SHL
Subject:	Stormwater Storage and Infiltration Systems: System 2B	MDK

SYSTEM 2B HANTUSH (1967) SOLUTION RESULTS

This spreadsheet will calculate the height of a groundwater mound beneath a stormwater infiltration basin. More information can be found in the U.S. Geological Survey Scientific Investigations Report 2010-5102 "Simulation of groundwater mounding beneath hypothetical stormwater infiltration basins".

The user must specify infiltration rate (R), specific yield (Sy), horizontal hydraulic conductivity (Kh), basin dimensions (x, y), duration of infiltration period (t), and the initial thickness of the saturated zone (hi(0), height of the water table if the bottom of the aquifer is the datum). For a square basin the half width equals the half length (x = y). For a rectangular basin, if the user wants the water-table changes perpendicular to the long side, specify x as the short dimension and y as the long dimension. Conversely, if the user wants the values perpendicular to the short side, specify y as the short dimension, x as the long dimension. All distances are from the center of the basin. Users can change the distances from the center of the basin at which water-table aquifer thickness are calculated.

Cells highlighted in yellow are values that can be changed by the user. Cells highlighted in red are output values based on user-specified inputs. The user MUST click the blue "Re-Calculate Now" button each time ANY of the user-specified inputs are changed otherwise necessary iterations to converge on the correct solution will not be done and values shown will be incorrect. Use consistent units for all input values (for example, feet and days)

Input Values		use consistent units (e.g. feet & days or inches & hours)	Conversion Table	
0.5800	R	Recharge (infiltration) rate (feet/day)	inch/hour	feet/day
0.150	Sy	Specific yield, Sy (dimensionless, between 0 and 1)	0.67	1.33
8.25	K	Horizontal hydraulic conductivity, Kh (feet/day)*	2.00	4.00
20.000	x	1/2 length of basin (x direction, in feet)	hours	days
13.000	y	1/2 width of basin (y direction, in feet)	36	1.50
3.000	t	duration of infiltration period (days)		
12.000	hi(0)	initial thickness of saturated zone (feet)		
13.639	h(max)	maximum thickness of saturated zone (beneath center of basin at end of infiltration period)		
1.639	Δh(max)	maximum groundwater mounding (beneath center of basin at end of infiltration period)		

Ground-water Mounding, in feet	Distance from center of basin in x direction, in feet
1.639	0
1.231	20
0.618	40
0.446	50
0.321	60
0.229	70
0.163	80
0.114	90
0.079	100
0.038	120

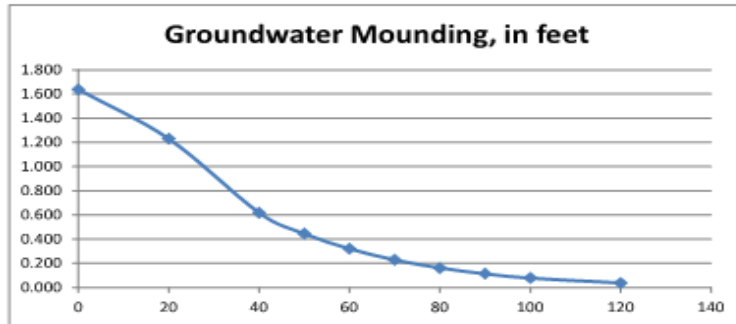

Disclaimer

This spreadsheet solving the Hantush (1967) equation for ground-water mounding beneath an infiltration basin is made available to the general public as a convenience for those wishing to replicate values documented in the USGS Scientific Investigations Report 2010-5102 "Groundwater mounding beneath hypothetical stormwater infiltration basins" or to calculate values based on user-specified site conditions. Any changes made to the spreadsheet (other than values identified as user-specified) after transmission from the USGS could have unintended, undesirable consequences. These consequences could include, but may not be limited to: erroneous output, numerical instabilities, and violations of underlying assumptions that are inherent in results presented in the accompanying USGS published report. The USGS assumes no responsibility for the consequences of any changes made to the spreadsheet. If changes are made to the spreadsheet, the user is responsible for documenting the changes and justifying the results and conclusions.

APPENDIX B

Pre-Development Conditions – HydroCAD Calculations

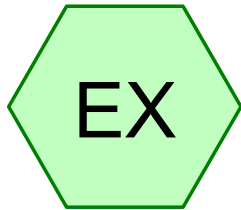

Existing Site



Existing Site

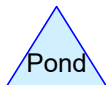
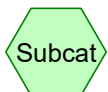

13569drainage-ex-pr

Prepared by Nitsch Engineering

HydroCAD® 10.00-20 s/n 00546 © 2017 HydroCAD Software Solutions LLC

Printed 4/14/2021

Page 2

Area Listing (selected nodes)

Area (sq-ft)	CN	Description (subcatchment-numbers)
3,157	74	>75% Grass cover, Good, HSG C (EX)
116,028	98	Paved parking, HSG C (EX)
70,802	98	Roofs, HSG C (EX)
189,987	98	TOTAL AREA

13569drainage-ex-pr

Prepared by Nitsch Engineering

HydroCAD® 10.00-20 s/n 00546 © 2017 HydroCAD Software Solutions LLC

Printed 4/14/2021

Page 3

Soil Listing (selected nodes)

Area (sq-ft)	Soil Group	Subcatchment Numbers
0	HSG A	
0	HSG B	
189,987	HSG C	EX
0	HSG D	
0	Other	
189,987		TOTAL AREA

13569drainage-ex-pr

Prepared by Nitsch Engineering

HydroCAD® 10.00-20 s/n 00546 © 2017 HydroCAD Software Solutions LLC

Printed 4/14/2021

Page 4

Ground Covers (selected nodes)

HSG-A (sq-ft)	HSG-B (sq-ft)	HSG-C (sq-ft)	HSG-D (sq-ft)	Other (sq-ft)	Total (sq-ft)	Ground Cover
0	0	3,157	0	0	3,157	>75% Grass cover, Good
0	0	116,028	0	0	116,028	Paved parking
0	0	70,802	0	0	70,802	Roofs
0	0	189,987	0	0	189,987	TOTAL AREA

13569drainage-ex-pr

Prepared by Nitsch Engineering

HydroCAD® 10.00-20 s/n 00546 © 2017 HydroCAD Software Solutions LLC

NOAA 24-hr D 2-Year Rainfall=3.26"

Printed 4/14/2021

Page 5

Time span=0.00-72.00 hrs, dt=0.05 hrs, 1441 points
Runoff by SCS TR-20 method, UH=SCS, Weighted-CN
Reach routing by Stor-Ind+Trans method - Pond routing by Stor-Ind method

SubcatchmentEX: Existing Site

Runoff Area=189,987 sf 98.34% Impervious Runoff Depth=3.03"
Tc=6.0 min CN=98 Runoff=13.04 cfs 47,928 cf

Reach DP-EX: Existing Site

Inflow=13.04 cfs 47,928 cf
Outflow=13.04 cfs 47,928 cf

Total Runoff Area = 189,987 sf Runoff Volume = 47,928 cf Average Runoff Depth = 3.03"
1.66% Pervious = 3,157 sf 98.34% Impervious = 186,830 sf

Summary for Subcatchment EX: Existing Site

Runoff = 13.04 cfs @ 12.13 hrs, Volume= 47,928 cf, Depth= 3.03"

Runoff by SCS TR-20 method, UH=SCS, Weighted-CN, Time Span= 0.00-72.00 hrs, dt= 0.05 hrs
 NOAA 24-hr D 2-Year Rainfall=3.26"

Area (sf)	CN	Description
70,802	98	Roofs, HSG C
116,028	98	Paved parking, HSG C
3,157	74	>75% Grass cover, Good, HSG C
189,987	98	Weighted Average
3,157		1.66% Pervious Area
186,830		98.34% Impervious Area

Tc (min)	Length (feet)	Slope (ft/ft)	Velocity (ft/sec)	Capacity (cfs)	Description
6.0					Direct Entry,

Subcatchment EX: Existing Site

Hydrograph

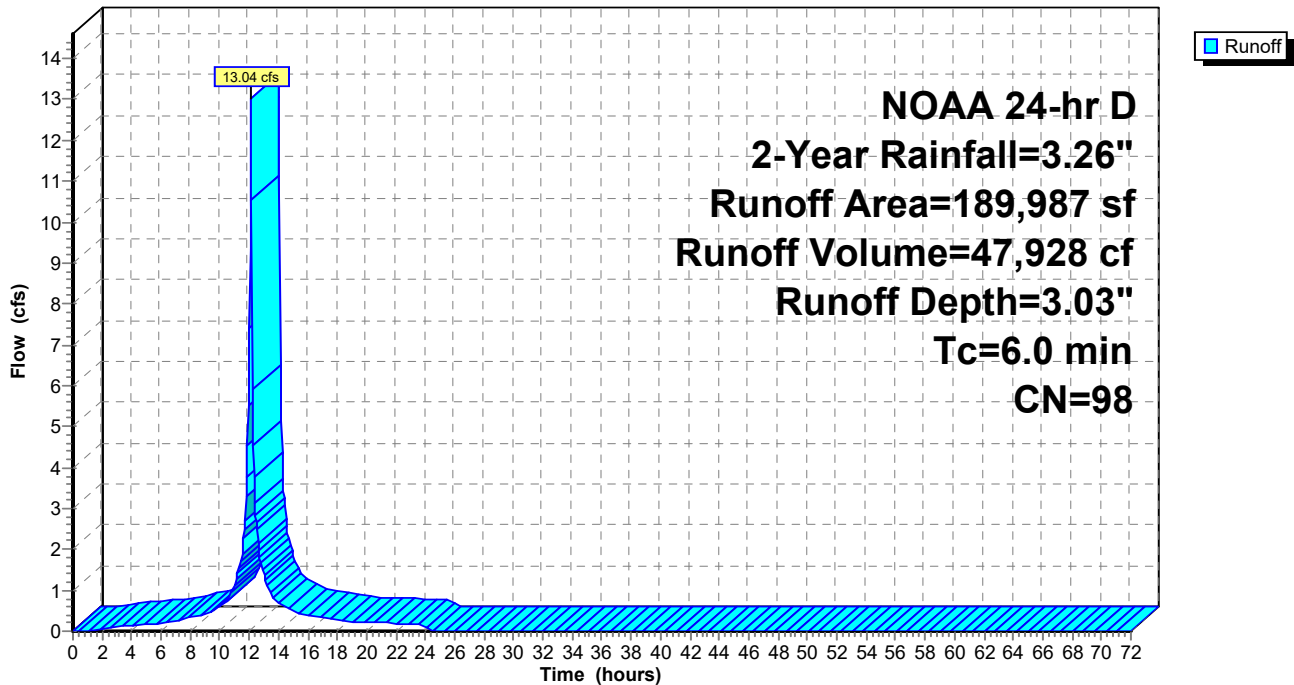

Summary for Reach DP-EX: Existing Site

[40] Hint: Not Described (Outflow=Inflow)

Inflow Area = 189,987 sf, 98.34% Impervious, Inflow Depth = 3.03" for 2-Year event
Inflow = 13.04 cfs @ 12.13 hrs, Volume= 47,928 cf
Outflow = 13.04 cfs @ 12.13 hrs, Volume= 47,928 cf, Atten= 0%, Lag= 0.0 min

Routing by Stor-Ind+Trans method, Time Span= 0.00-72.00 hrs, dt= 0.05 hrs

Reach DP-EX: Existing Site

Hydrograph

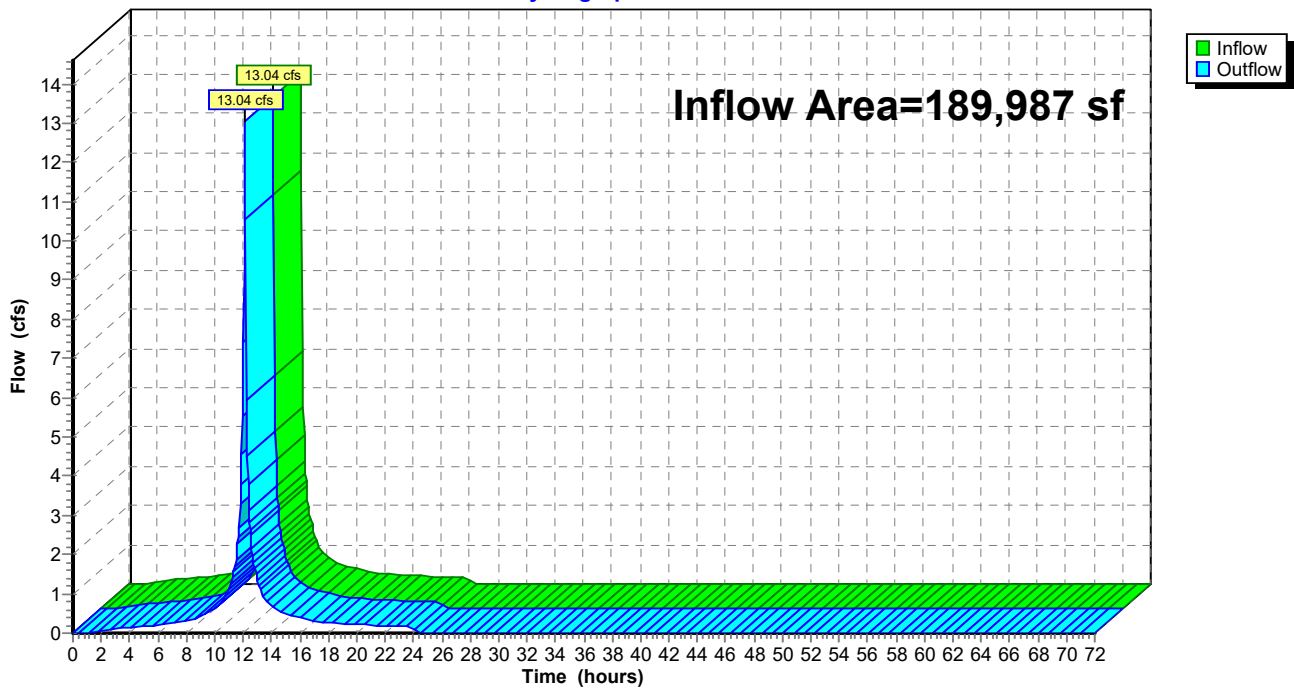

13569drainage-ex-pr

NOAA 24-hr D 10-Year Rainfall=5.14"

Prepared by Nitsch Engineering

Printed 4/14/2021

HydroCAD® 10.00-20 s/n 00546 © 2017 HydroCAD Software Solutions LLC

Page 8

Time span=0.00-72.00 hrs, dt=0.05 hrs, 1441 points
Runoff by SCS TR-20 method, UH=SCS, Weighted-CN
Reach routing by Stor-Ind+Trans method - Pond routing by Stor-Ind method

SubcatchmentEX: Existing Site

Runoff Area=189,987 sf 98.34% Impervious Runoff Depth=4.90"
Tc=6.0 min CN=98 Runoff=20.70 cfs 77,625 cf

Reach DP-EX: Existing Site

Inflow=20.70 cfs 77,625 cf
Outflow=20.70 cfs 77,625 cf

Total Runoff Area = 189,987 sf Runoff Volume = 77,625 cf Average Runoff Depth = 4.90"
1.66% Pervious = 3,157 sf 98.34% Impervious = 186,830 sf

Summary for Subcatchment EX: Existing Site

Runoff = 20.70 cfs @ 12.13 hrs, Volume= 77,625 cf, Depth= 4.90"

Runoff by SCS TR-20 method, UH=SCS, Weighted-CN, Time Span= 0.00-72.00 hrs, dt= 0.05 hrs
 NOAA 24-hr D 10-Year Rainfall=5.14"

Area (sf)	CN	Description
70,802	98	Roofs, HSG C
116,028	98	Paved parking, HSG C
3,157	74	>75% Grass cover, Good, HSG C
189,987	98	Weighted Average
3,157		1.66% Pervious Area
186,830		98.34% Impervious Area

Tc (min)	Length (feet)	Slope (ft/ft)	Velocity (ft/sec)	Capacity (cfs)	Description
6.0					Direct Entry,

Subcatchment EX: Existing Site

Hydrograph

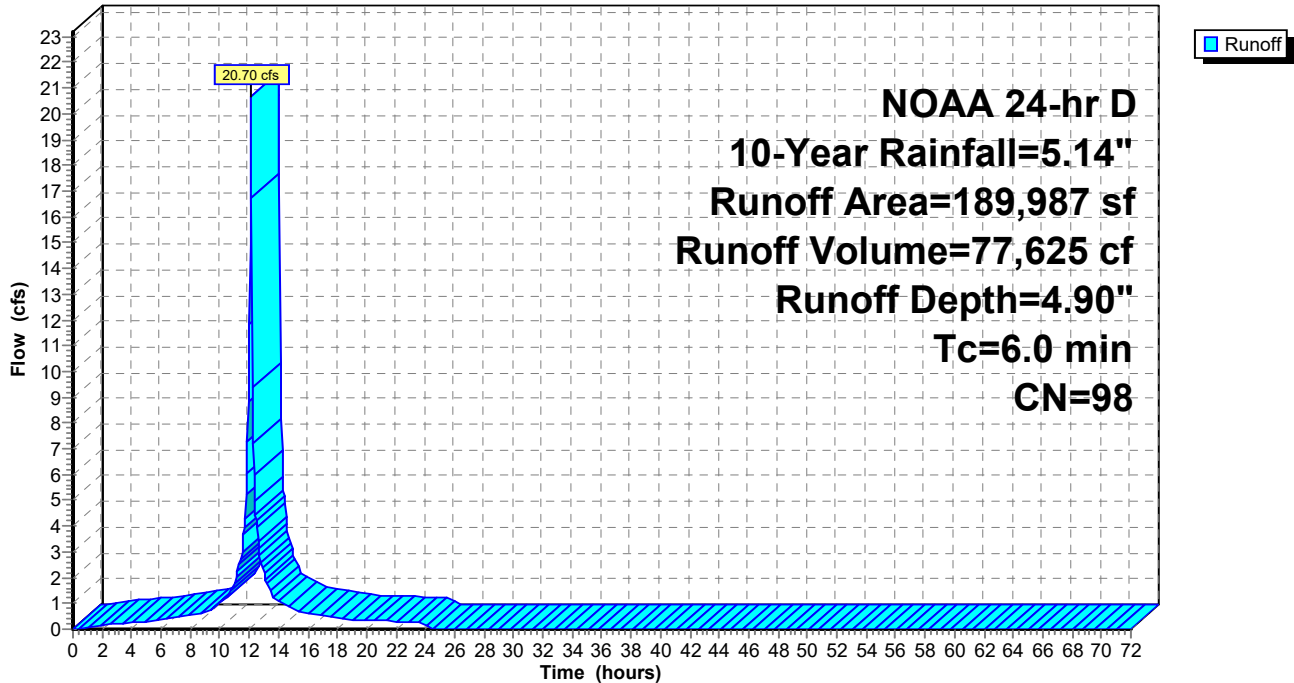

Summary for Reach DP-EX: Existing Site

[40] Hint: Not Described (Outflow=Inflow)

Inflow Area = 189,987 sf, 98.34% Impervious, Inflow Depth = 4.90" for 10-Year event
Inflow = 20.70 cfs @ 12.13 hrs, Volume= 77,625 cf
Outflow = 20.70 cfs @ 12.13 hrs, Volume= 77,625 cf, Atten= 0%, Lag= 0.0 min

Routing by Stor-Ind+Trans method, Time Span= 0.00-72.00 hrs, dt= 0.05 hrs

Reach DP-EX: Existing Site

Hydrograph

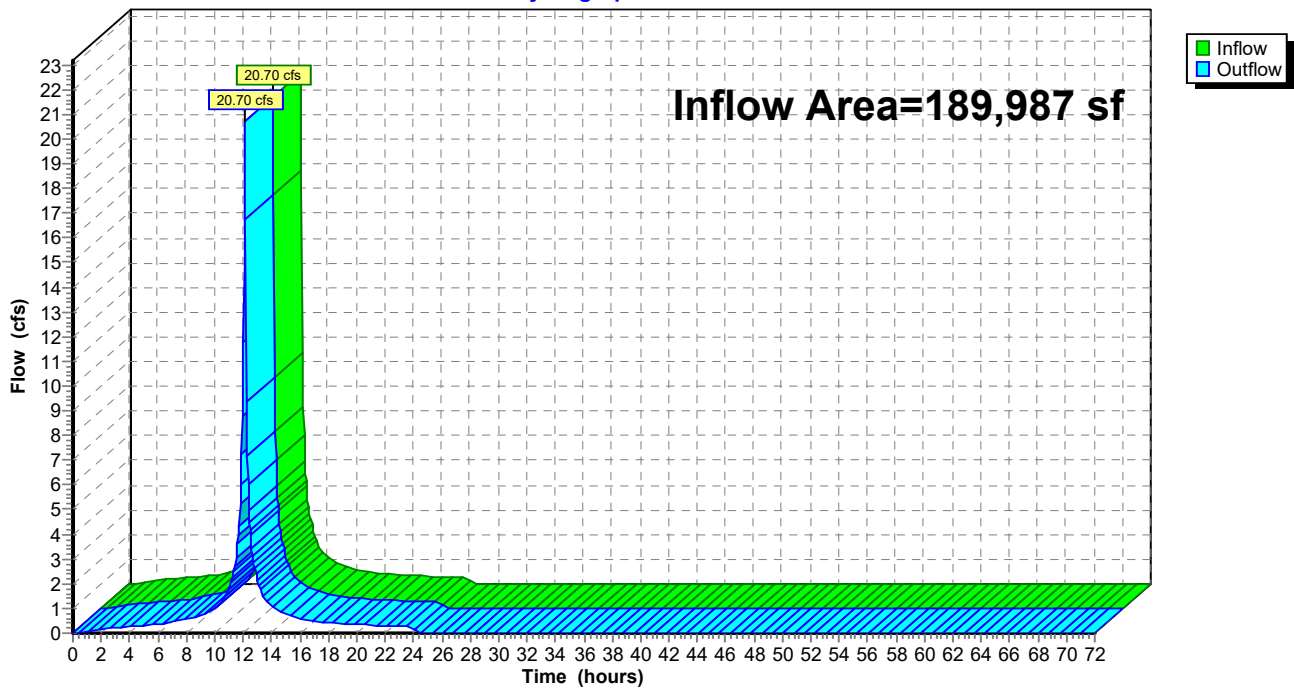

13569drainage-ex-pr

NOAA 24-hr D 25-Year Rainfall=6.32"

Prepared by Nitsch Engineering

Printed 4/14/2021

HydroCAD® 10.00-20 s/n 00546 © 2017 HydroCAD Software Solutions LLC

Page 11

Time span=0.00-72.00 hrs, dt=0.05 hrs, 1441 points
Runoff by SCS TR-20 method, UH=SCS, Weighted-CN
Reach routing by Stor-Ind+Trans method - Pond routing by Stor-Ind method

SubcatchmentEX: Existing Site

Runoff Area=189,987 sf 98.34% Impervious Runoff Depth=6.08"
Tc=6.0 min CN=98 Runoff=25.50 cfs 96,284 cf

Reach DP-EX: Existing Site

Inflow=25.50 cfs 96,284 cf
Outflow=25.50 cfs 96,284 cf

Total Runoff Area = 189,987 sf Runoff Volume = 96,284 cf Average Runoff Depth = 6.08"
1.66% Pervious = 3,157 sf 98.34% Impervious = 186,830 sf

Summary for Subcatchment EX: Existing Site

Runoff = 25.50 cfs @ 12.13 hrs, Volume= 96,284 cf, Depth= 6.08"

Runoff by SCS TR-20 method, UH=SCS, Weighted-CN, Time Span= 0.00-72.00 hrs, dt= 0.05 hrs
 NOAA 24-hr D 25-Year Rainfall=6.32"

Area (sf)	CN	Description
70,802	98	Roofs, HSG C
116,028	98	Paved parking, HSG C
3,157	74	>75% Grass cover, Good, HSG C
189,987	98	Weighted Average
3,157		1.66% Pervious Area
186,830		98.34% Impervious Area

Tc (min)	Length (feet)	Slope (ft/ft)	Velocity (ft/sec)	Capacity (cfs)	Description
6.0					Direct Entry,

Subcatchment EX: Existing Site

Hydrograph

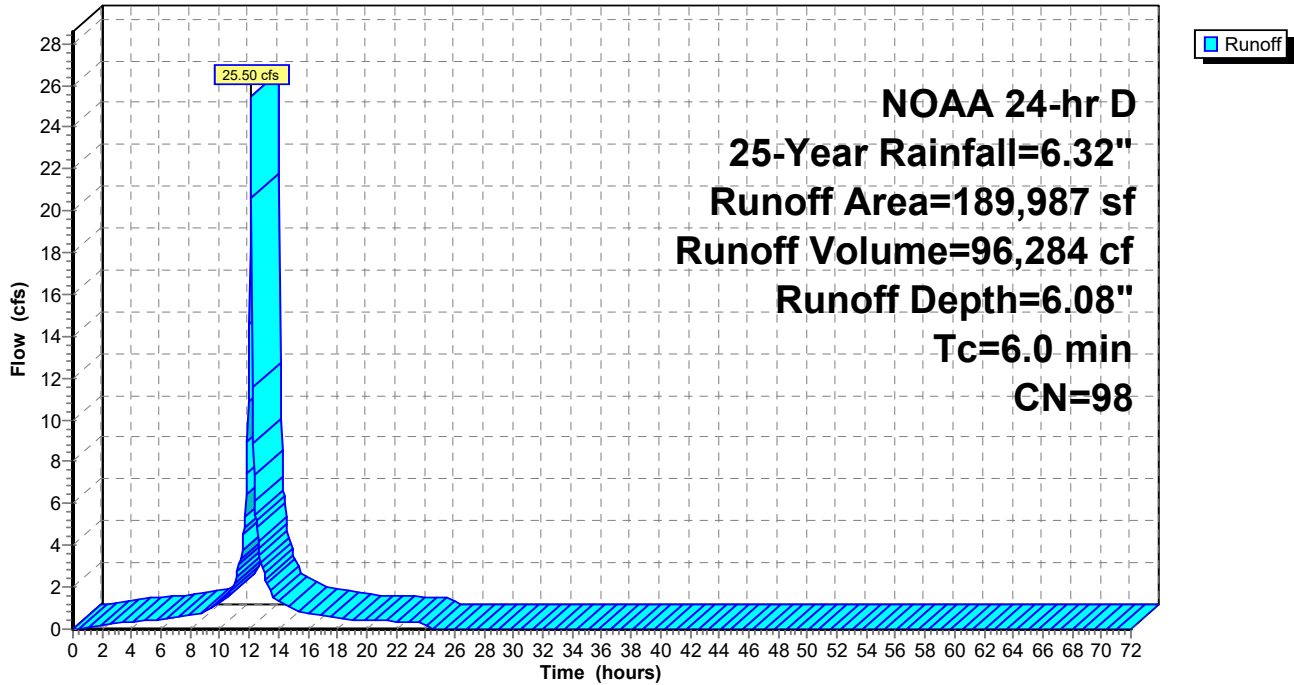

Summary for Reach DP-EX: Existing Site

[40] Hint: Not Described (Outflow=Inflow)

Inflow Area = 189,987 sf, 98.34% Impervious, Inflow Depth = 6.08" for 25-Year event
Inflow = 25.50 cfs @ 12.13 hrs, Volume= 96,284 cf
Outflow = 25.50 cfs @ 12.13 hrs, Volume= 96,284 cf, Atten= 0%, Lag= 0.0 min

Routing by Stor-Ind+Trans method, Time Span= 0.00-72.00 hrs, dt= 0.05 hrs

Reach DP-EX: Existing Site

Hydrograph

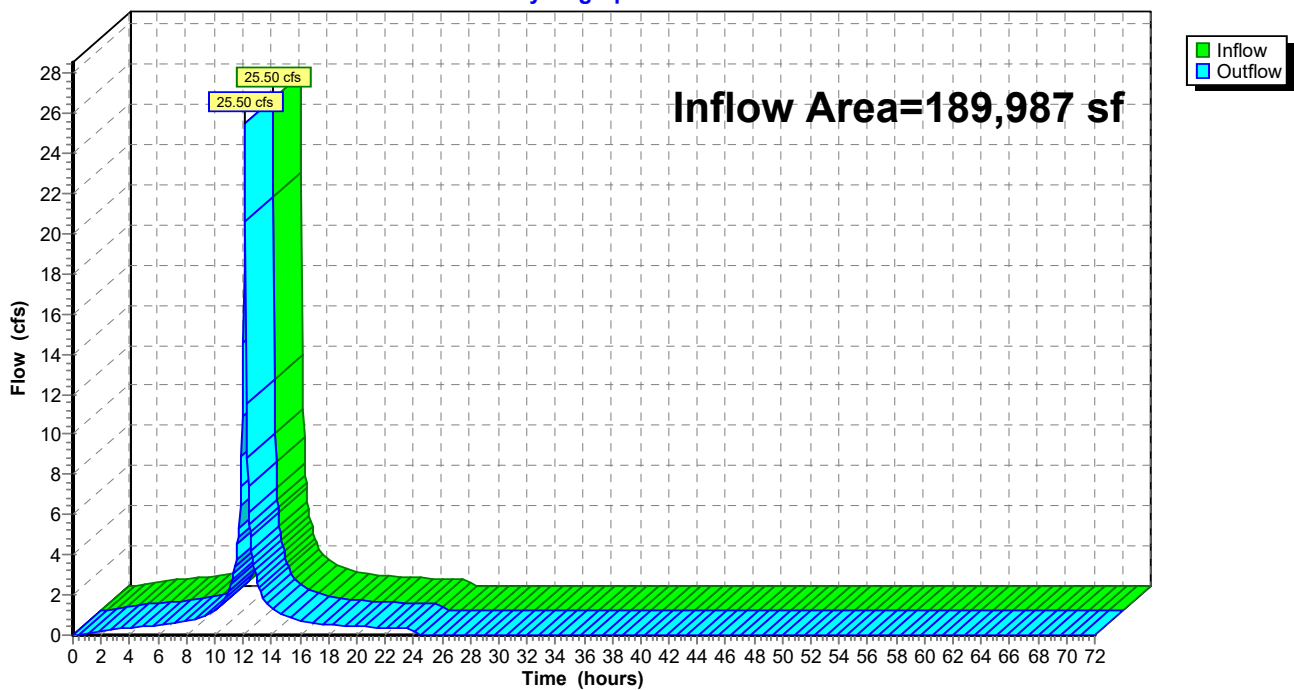

13569drainage-ex-pr

NOAA 24-hr D 100-Year Rainfall=8.14"

Prepared by Nitsch Engineering

Printed 4/14/2021

HydroCAD® 10.00-20 s/n 00546 © 2017 HydroCAD Software Solutions LLC

Page 14

Time span=0.00-72.00 hrs, dt=0.05 hrs, 1441 points
Runoff by SCS TR-20 method, UH=SCS, Weighted-CN
Reach routing by Stor-Ind+Trans method - Pond routing by Stor-Ind method

SubcatchmentEX: Existing Site

Runoff Area=189,987 sf 98.34% Impervious Runoff Depth=7.90"
Tc=6.0 min CN=98 Runoff=32.89 cfs 125,077 cf

Reach DP-EX: Existing Site

Inflow=32.89 cfs 125,077 cf
Outflow=32.89 cfs 125,077 cf

Total Runoff Area = 189,987 sf Runoff Volume = 125,077 cf Average Runoff Depth = 7.90"
1.66% Pervious = 3,157 sf 98.34% Impervious = 186,830 sf

Summary for Subcatchment EX: Existing Site

Runoff = 32.89 cfs @ 12.13 hrs, Volume= 125,077 cf, Depth= 7.90"

Runoff by SCS TR-20 method, UH=SCS, Weighted-CN, Time Span= 0.00-72.00 hrs, dt= 0.05 hrs
 NOAA 24-hr D 100-Year Rainfall=8.14"

Area (sf)	CN	Description
70,802	98	Roofs, HSG C
116,028	98	Paved parking, HSG C
3,157	74	>75% Grass cover, Good, HSG C
189,987	98	Weighted Average
3,157		1.66% Pervious Area
186,830		98.34% Impervious Area

Tc (min)	Length (feet)	Slope (ft/ft)	Velocity (ft/sec)	Capacity (cfs)	Description
6.0					Direct Entry,

Subcatchment EX: Existing Site

Hydrograph

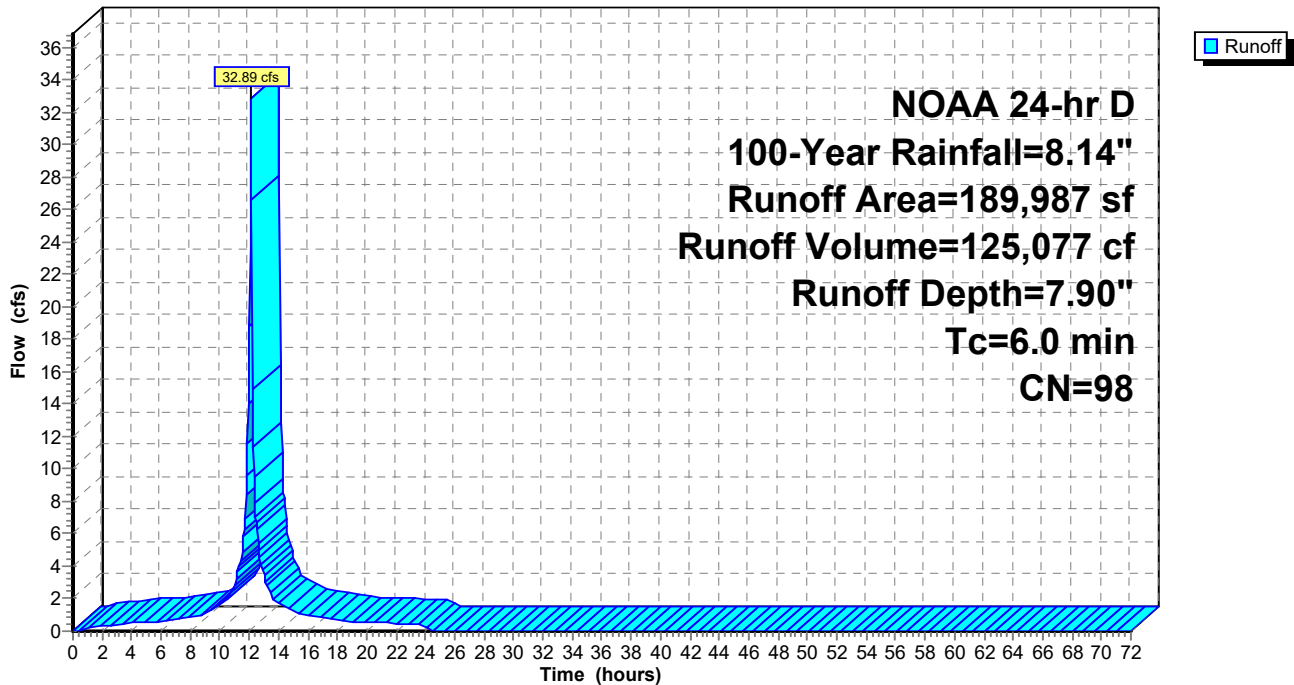

Summary for Reach DP-EX: Existing Site

[40] Hint: Not Described (Outflow=Inflow)

Inflow Area = 189,987 sf, 98.34% Impervious, Inflow Depth = 7.90" for 100-Year event
Inflow = 32.89 cfs @ 12.13 hrs, Volume= 125,077 cf
Outflow = 32.89 cfs @ 12.13 hrs, Volume= 125,077 cf, Atten= 0%, Lag= 0.0 min

Routing by Stor-Ind+Trans method, Time Span= 0.00-72.00 hrs, dt= 0.05 hrs

Reach DP-EX: Existing Site

Hydrograph

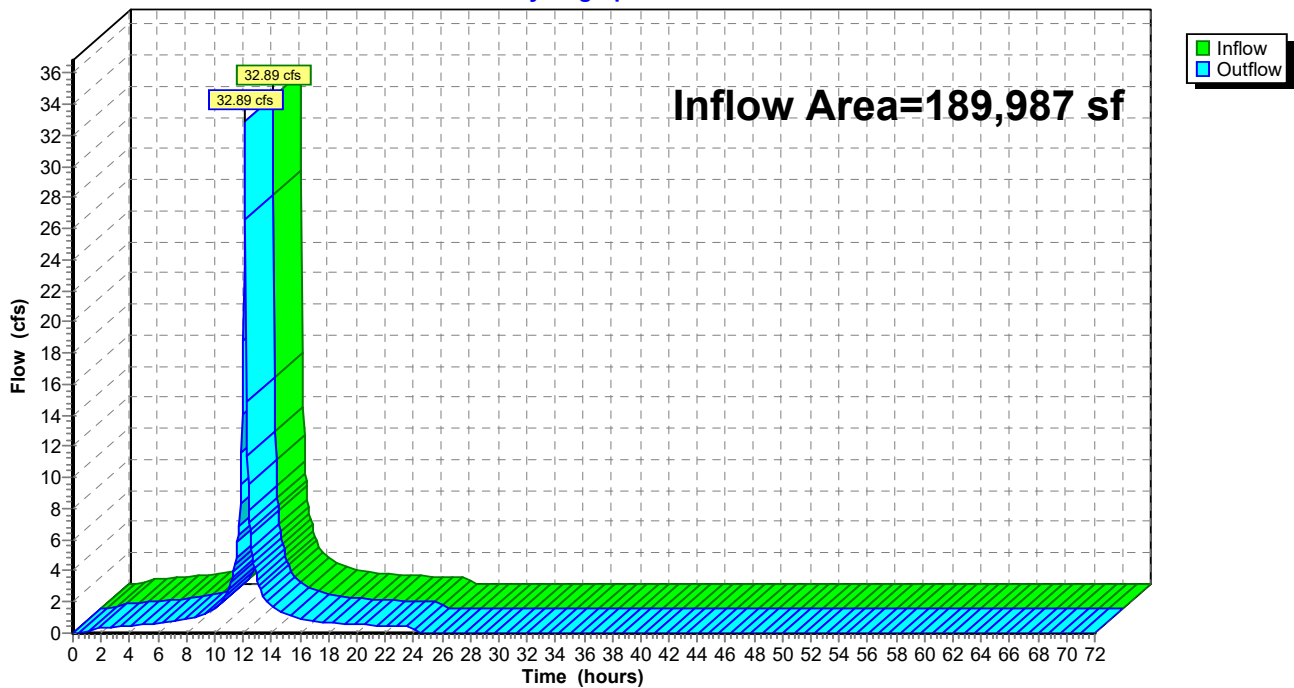

APPENDIX C

Post-Development Conditions – HydroCAD Calculations

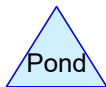
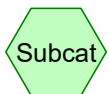
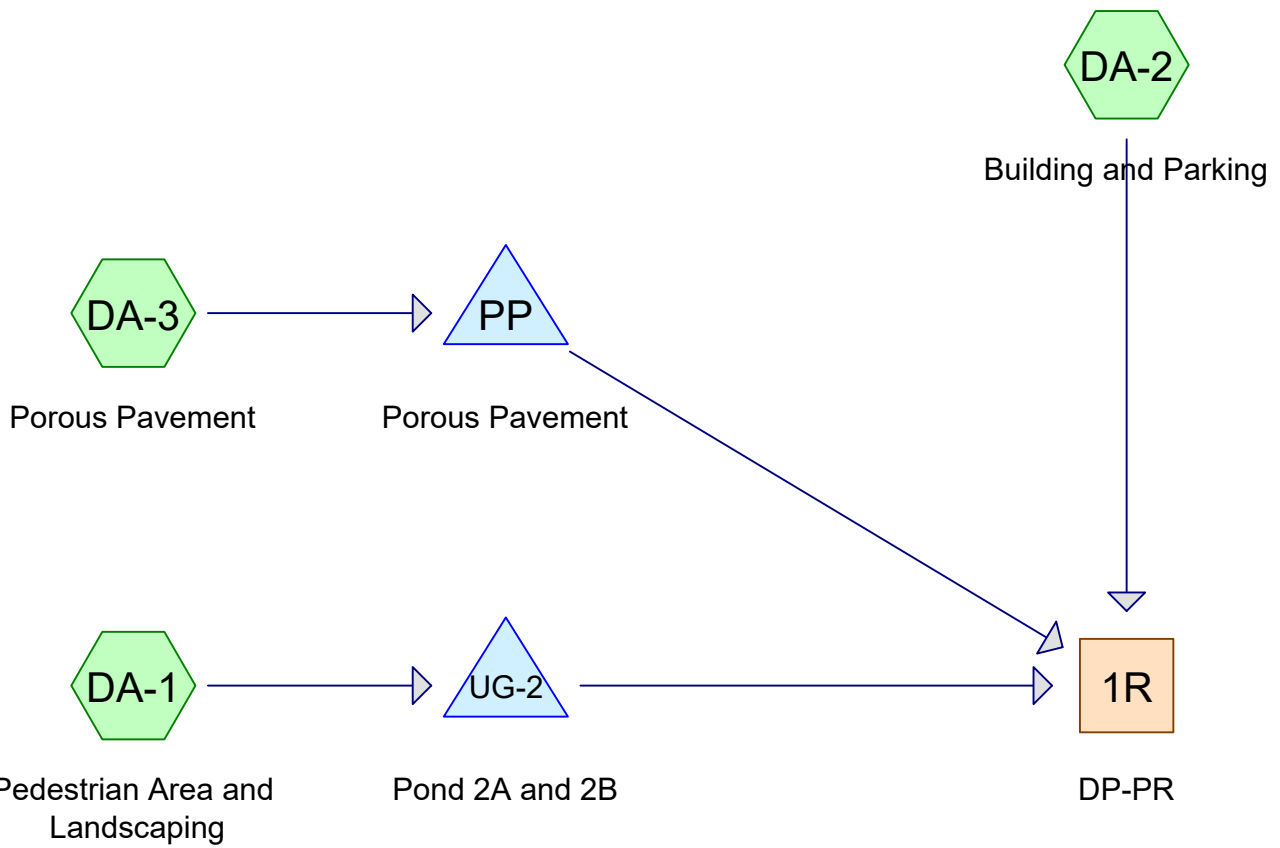

13569drainage-ex-pr

Prepared by Nitsch Engineering

HydroCAD® 10.00-20 s/n 00546 © 2017 HydroCAD Software Solutions LLC

Printed 4/14/2021

Page 2

Area Listing (selected nodes)

Area (sq-ft)	CN	Description (subcatchment-numbers)
28,474	74	>75% Grass cover, Good, HSG C (DA-1, DA-2)
68,629	98	Paved parking, HSG C (DA-2)
14,085	98	Porous Asphalt (DA-3)
53,646	98	Roofs, HSG C (DA-2)
25,153	98	Site Impervious (DA-1)
189,987	94	TOTAL AREA

13569drainage-ex-pr

Prepared by Nitsch Engineering

HydroCAD® 10.00-20 s/n 00546 © 2017 HydroCAD Software Solutions LLC

Printed 4/14/2021

Page 3

Soil Listing (selected nodes)

Area (sq-ft)	Soil Group	Subcatchment Numbers
0	HSG A	
0	HSG B	
150,749	HSG C	DA-1, DA-2
0	HSG D	
39,238	Other	DA-1, DA-3
189,987		TOTAL AREA

13569drainage-ex-pr

Prepared by Nitsch Engineering

HydroCAD® 10.00-20 s/n 00546 © 2017 HydroCAD Software Solutions LLC

Printed 4/14/2021

Page 4

Ground Covers (selected nodes)

HSG-A (sq-ft)	HSG-B (sq-ft)	HSG-C (sq-ft)	HSG-D (sq-ft)	Other (sq-ft)	Total (sq-ft)	Ground Cover
0	0	28,474	0	0	28,474	>75% Grass cover, Good
0	0	68,629	0	0	68,629	Paved parking
0	0	0	0	14,085	14,085	Porous Asphalt
0	0	53,646	0	0	53,646	Roofs
0	0	0	0	25,153	25,153	Site Impervious
0	0	150,749	0	39,238	189,987	TOTAL AREA

13569drainage-ex-pr

Prepared by Nitsch Engineering

HydroCAD® 10.00-20 s/n 00546 © 2017 HydroCAD Software Solutions LLC

NOAA 24-hr D 2-Year Rainfall=3.26"

Printed 4/14/2021

Page 5

Time span=0.00-72.00 hrs, dt=0.05 hrs, 1441 points
Runoff by SCS TR-20 method, UH=SCS, Weighted-CN
Reach routing by Stor-Ind+Trans method - Pond routing by Stor-Ind method

SubcatchmentDA-1: Pedestrian Area and Runoff Area=42,623 sf 59.01% Impervious Runoff Depth=2.05"
Tc=6.0 min CN=88 Runoff=2.25 cfs 7,285 cf

SubcatchmentDA-2: Building and ParkingRunoff Area=133,279 sf 91.74% Impervious Runoff Depth=2.81"
Tc=6.0 min CN=96 Runoff=8.87 cfs 31,191 cf

SubcatchmentDA-3: Porous Pavement Runoff Area=14,085 sf 100.00% Impervious Runoff Depth=3.03"
Tc=60.0 min CN=98 Runoff=0.38 cfs 3,553 cf

Reach 1R: DP-PR Inflow=8.87 cfs 36,219 cf
Outflow=8.87 cfs 36,219 cf

Pond PP: Porous Pavement Peak Elev=14.59' Storage=2,149 cf Inflow=0.38 cfs 3,553 cf
Outflow=0.15 cfs 1,779 cf

Pond UG-2: Pond 2A and 2B Peak Elev=14.58' Storage=4,091 cf Inflow=2.25 cfs 7,285 cf
Outflow=0.38 cfs 3,250 cf

Total Runoff Area = 189,987 sf Runoff Volume = 42,029 cf Average Runoff Depth = 2.65"
14.99% Pervious = 28,474 sf 85.01% Impervious = 161,513 sf

Summary for Subcatchment DA-1: Pedestrian Area and Landscaping

Runoff = 2.25 cfs @ 12.13 hrs, Volume= 7,285 cf, Depth= 2.05"

Runoff by SCS TR-20 method, UH=SCS, Weighted-CN, Time Span= 0.00-72.00 hrs, dt= 0.05 hrs
 NOAA 24-hr D 2-Year Rainfall=3.26"

Area (sf)	CN	Description
17,470	74	>75% Grass cover, Good, HSG C
* 25,153	98	Slte Impervious
42,623	88	Weighted Average
17,470		40.99% Pervious Area
25,153		59.01% Impervious Area

Tc (min)	Length (feet)	Slope (ft/ft)	Velocity (ft/sec)	Capacity (cfs)	Description
6.0					Direct Entry,

Subcatchment DA-1: Pedestrian Area and Landscaping

Hydrograph

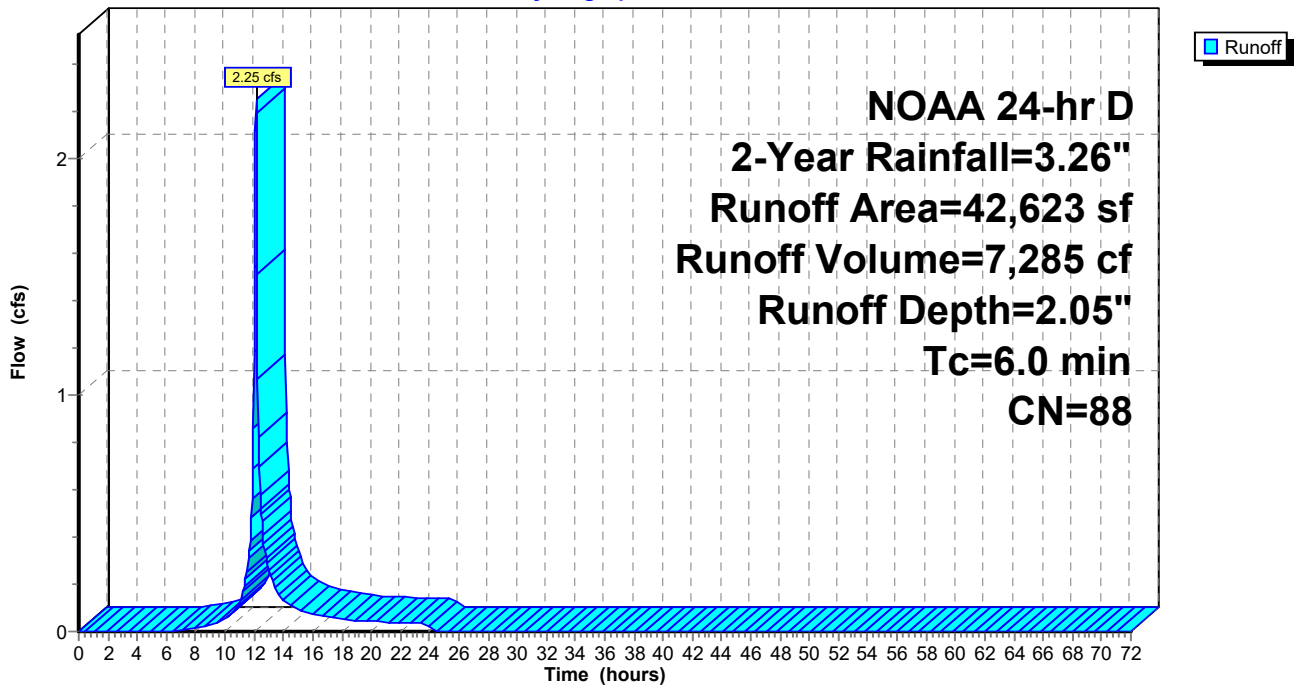

Summary for Subcatchment DA-2: Building and Parking

Runoff = 8.87 cfs @ 12.13 hrs, Volume= 31,191 cf, Depth= 2.81"

Runoff by SCS TR-20 method, UH=SCS, Weighted-CN, Time Span= 0.00-72.00 hrs, dt= 0.05 hrs
 NOAA 24-hr D 2-Year Rainfall=3.26"

Area (sf)	CN	Description
11,004	74	>75% Grass cover, Good, HSG C
68,629	98	Paved parking, HSG C
53,646	98	Roofs, HSG C
133,279	96	Weighted Average
11,004		8.26% Pervious Area
122,275		91.74% Impervious Area

Tc (min)	Length (feet)	Slope (ft/ft)	Velocity (ft/sec)	Capacity (cfs)	Description
6.0					Direct Entry,

Subcatchment DA-2: Building and Parking

Hydrograph

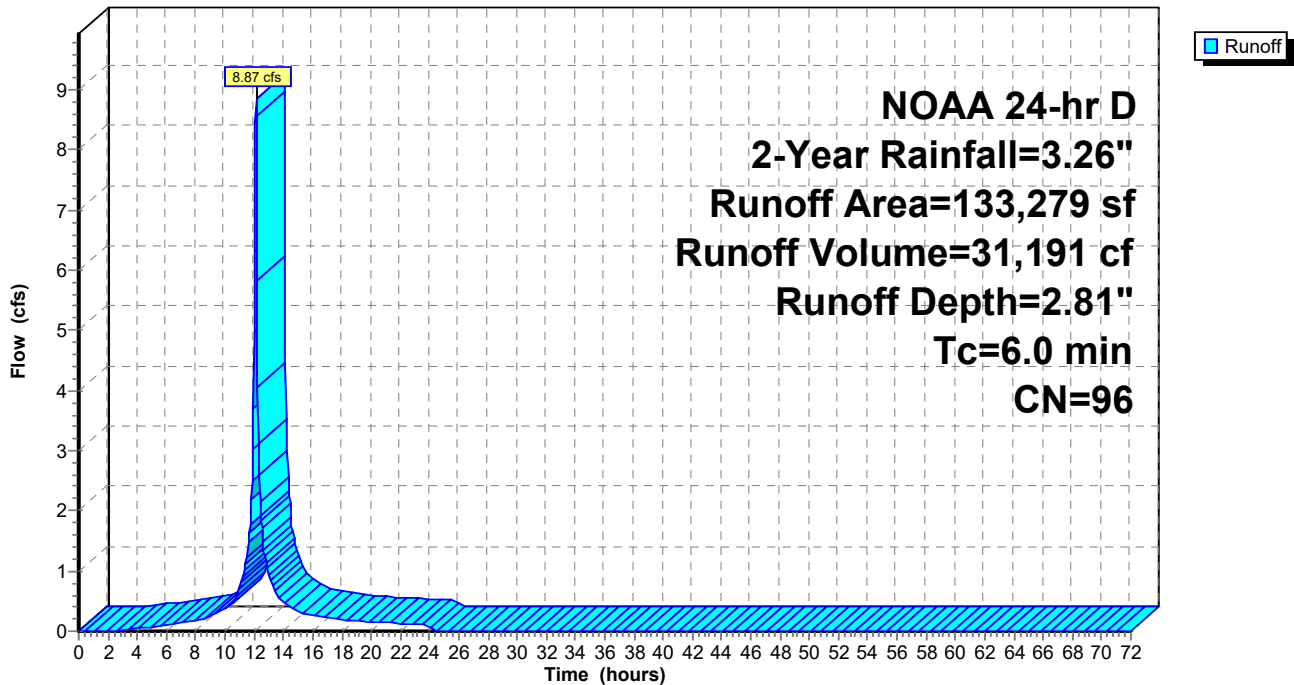

Summary for Subcatchment DA-3: Porous Pavement

Runoff = 0.38 cfs @ 12.77 hrs, Volume= 3,553 cf, Depth= 3.03"

Runoff by SCS TR-20 method, UH=SCS, Weighted-CN, Time Span= 0.00-72.00 hrs, dt= 0.05 hrs
 NOAA 24-hr D 2-Year Rainfall=3.26"

Area (sf)	CN	Description
* 14,085	98	Porous Asphalt
14,085		100.00% Impervious Area

Tc (min)	Length (feet)	Slope (ft/ft)	Velocity (ft/sec)	Capacity (cfs)	Description
60.0					Direct Entry,

Subcatchment DA-3: Porous Pavement

Hydrograph

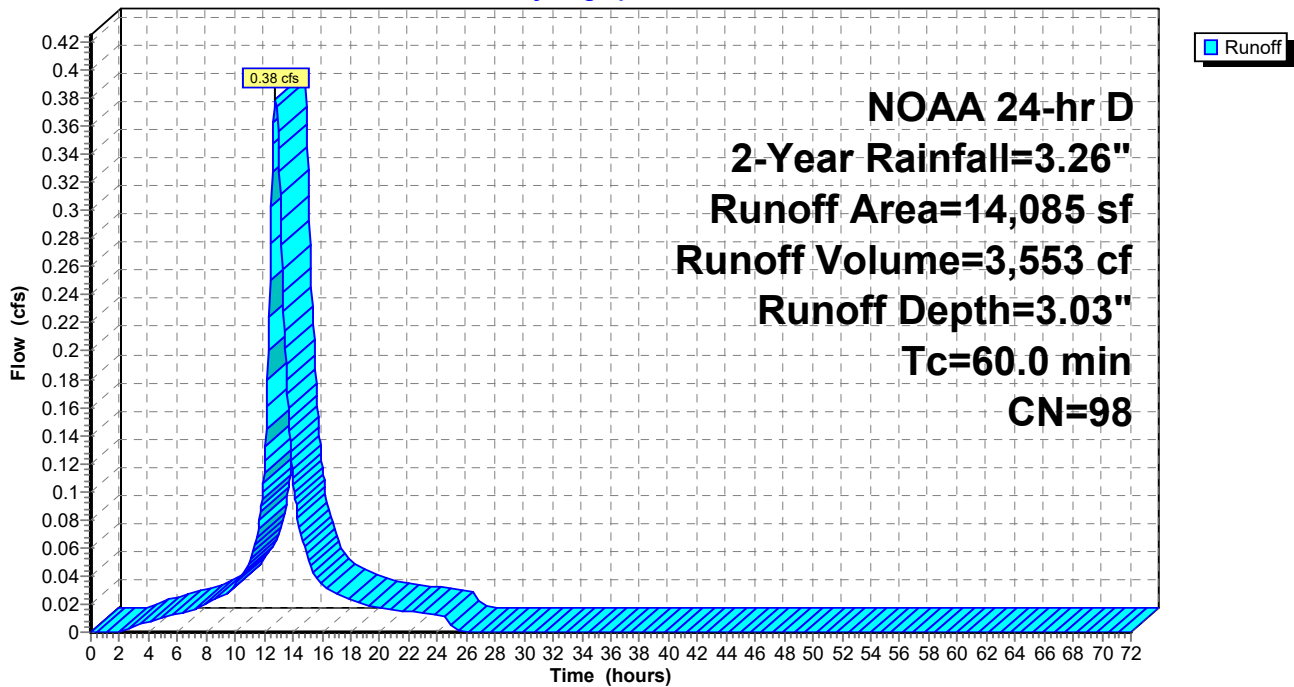

Summary for Reach 1R: DP-PR

[40] Hint: Not Described (Outflow=Inflow)

Inflow Area = 189,987 sf, 85.01% Impervious, Inflow Depth = 2.29" for 2-Year event
Inflow = 8.87 cfs @ 12.13 hrs, Volume= 36,219 cf
Outflow = 8.87 cfs @ 12.13 hrs, Volume= 36,219 cf, Atten= 0%, Lag= 0.0 min

Routing by Stor-Ind+Trans method, Time Span= 0.00-72.00 hrs, dt= 0.05 hrs

Reach 1R: DP-PR

Hydrograph

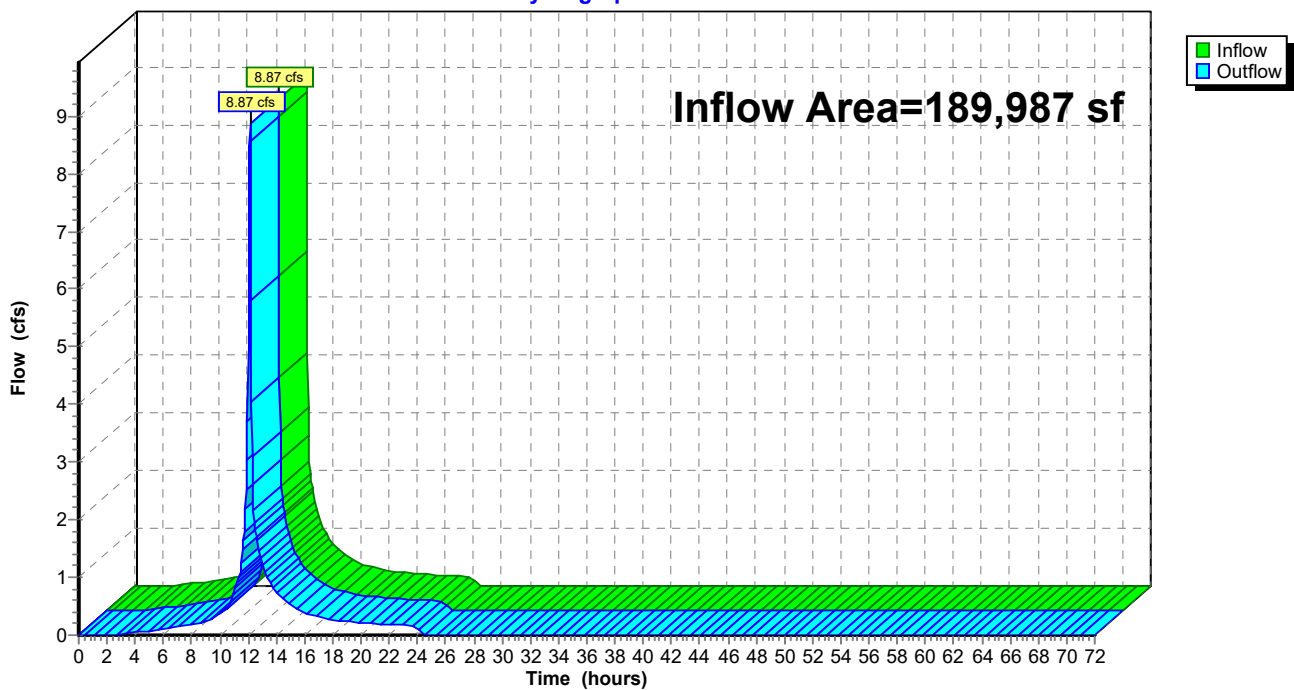

Summary for Pond PP: Porous Pavement

Inflow Area = 14,085 sf, 100.00% Impervious, Inflow Depth = 3.03" for 2-Year event
 Inflow = 0.38 cfs @ 12.77 hrs, Volume= 3,553 cf
 Outflow = 0.15 cfs @ 13.69 hrs, Volume= 1,779 cf, Atten= 60%, Lag= 55.1 min
 Primary = 0.15 cfs @ 13.69 hrs, Volume= 1,779 cf

Routing by Stor-Ind method, Time Span= 0.00-72.00 hrs, dt= 0.05 hrs
 Peak Elev= 14.59' @ 13.69 hrs Surf.Area= 14,085 sf Storage= 2,149 cf

Plug-Flow detention time= 363.3 min calculated for 1,779 cf (50% of inflow)
 Center-of-Mass det. time= 219.4 min (1,027.5 - 808.1)

Volume	Invert	Avail.Storage	Storage Description
#1	16.33'	479 cf	4" Pervious Pavement (Prismatic) Listed below (Recalc) 4,789 cf Overall x 10.0% Voids
#2	16.00'	1,394 cf	4" Choker Course (Prismatic) Listed below (Recalc) 4,648 cf Overall x 30.0% Voids
#3	15.33'	2,831 cf	8" Filter Course (Prismatic) Listed below (Recalc) 9,437 cf Overall x 30.0% Voids
#4	15.08'	1,056 cf	3" Filter Blanket (Prismatic) Listed below (Recalc) 3,521 cf Overall x 30.0% Voids
#5	14.08'	4,226 cf	12" Reservoir (Prismatic) Listed below (Recalc) 14,085 cf Overall x 30.0% Voids
		9,986 cf	Total Available Storage

Elevation (feet)	Surf.Area (sq-ft)	Inc.Store (cubic-feet)	Cum.Store (cubic-feet)
16.33	14,085	0	0
16.67	14,085	4,789	4,789

Elevation (feet)	Surf.Area (sq-ft)	Inc.Store (cubic-feet)	Cum.Store (cubic-feet)
16.00	14,085	0	0
16.33	14,085	4,648	4,648

Elevation (feet)	Surf.Area (sq-ft)	Inc.Store (cubic-feet)	Cum.Store (cubic-feet)
15.33	14,085	0	0
16.00	14,085	9,437	9,437

Elevation (feet)	Surf.Area (sq-ft)	Inc.Store (cubic-feet)	Cum.Store (cubic-feet)
15.08	14,085	0	0
15.33	14,085	3,521	3,521

Elevation (feet)	Surf.Area (sq-ft)	Inc.Store (cubic-feet)	Cum.Store (cubic-feet)
14.08	14,085	0	0
15.08	14,085	14,085	14,085

Device	Routing	Invert	Outlet Devices
#1	Primary	14.50'	4.0" Vert. Orifice/Grate X 8.00 C= 0.600

Primary OutFlow Max=0.15 cfs @ 13.69 hrs HW=14.59' (Free Discharge)
↑1=Orifice/Grate (Orifice Controls 0.15 cfs @ 1.01 fps)

Pond PP: Porous Pavement

Hydrograph

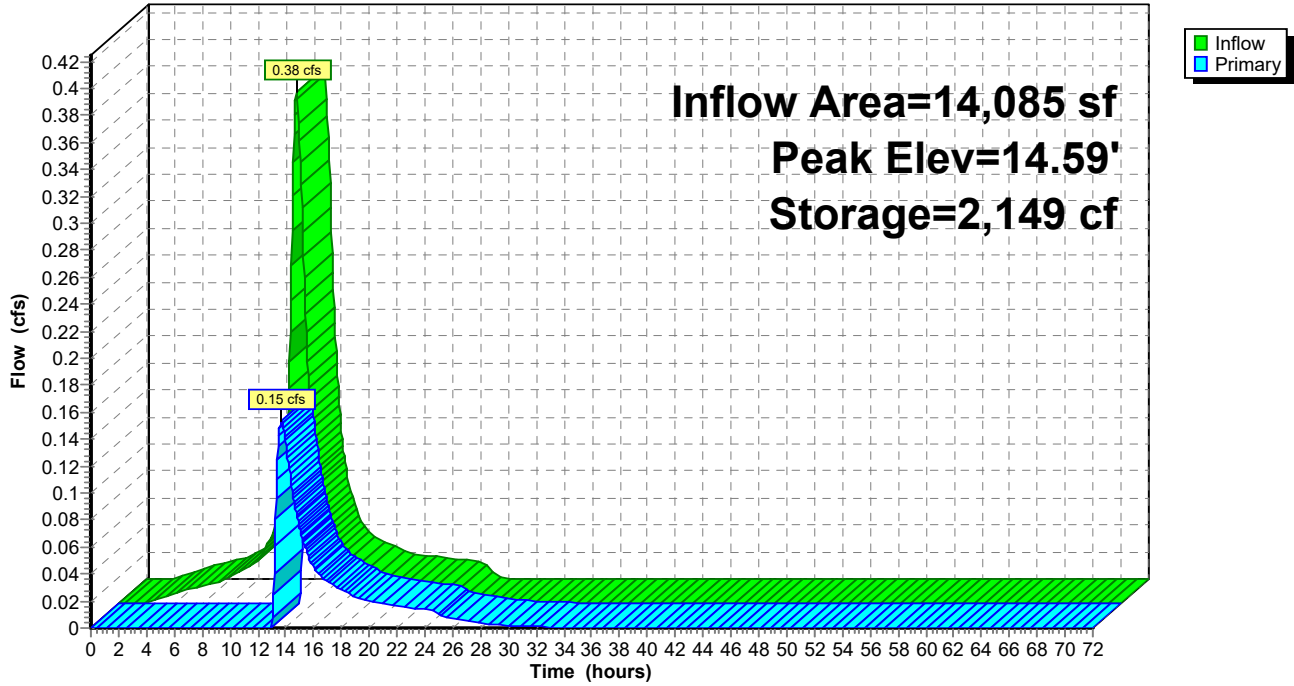

Summary for Pond UG-2: Pond 2A and 2B

Inflow Area = 42,623 sf, 59.01% Impervious, Inflow Depth = 2.05" for 2-Year event
 Inflow = 2.25 cfs @ 12.13 hrs, Volume= 7,285 cf
 Outflow = 0.38 cfs @ 12.67 hrs, Volume= 3,250 cf, Atten= 83%, Lag= 32.6 min
 Primary = 0.38 cfs @ 12.67 hrs, Volume= 3,250 cf

Routing by Stor-Ind method, Time Span= 0.00-72.00 hrs, dt= 0.05 hrs
 Peak Elev= 14.58' @ 12.65 hrs Surf.Area= 2,340 sf Storage= 4,091 cf

Plug-Flow detention time= 282.6 min calculated for 3,250 cf (45% of inflow)
 Center-of-Mass det. time= 152.8 min (975.3 - 822.5)

Volume	Invert	Avail.Storage	Storage Description
#1A	11.50'	745 cf	25.25'W x 39.22'L x 3.67'H Field A 3,631 cf Overall - 1,149 cf Embedded = 2,482 cf x 30.0% Voids
#2A	12.00'	1,149 cf	ADS_StormTech SC-740 +Cap x 25 Inside #1 Effective Size= 44.6"W x 30.0"H => 6.45 sf x 7.12'L = 45.9 cf Overall Size= 51.0"W x 30.0"H x 7.56"L with 0.44' Overlap 5 Rows of 5 Chambers
#3B	11.50'	1,002 cf	25.25'W x 53.46'L x 3.67'H Field B 4,949 cf Overall - 1,608 cf Embedded = 3,341 cf x 30.0% Voids
#4B	12.00'	1,608 cf	ADS_StormTech SC-740 +Cap x 35 Inside #3 Effective Size= 44.6"W x 30.0"H => 6.45 sf x 7.12'L = 45.9 cf Overall Size= 51.0"W x 30.0"H x 7.56"L with 0.44' Overlap 5 Rows of 7 Chambers
		4,503 cf	Total Available Storage

Storage Group A created with Chamber Wizard
 Storage Group B created with Chamber Wizard

Device	Routing	Invert	Outlet Devices
#1	Primary	14.50'	5.0' long Sharp-Crested Rectangular Weir 2 End Contraction(s)

Primary OutFlow Max=0.36 cfs @ 12.67 hrs HW=14.58' (Free Discharge)
 ↑1=Sharp-Crested Rectangular Weir (Weir Controls 0.36 cfs @ 0.92 fps)

Pond UG-2: Pond 2A and 2B - Chamber Wizard Field A

Chamber Model = ADS_StormTechSC-740 +Cap (ADS StormTech®SC-740 with cap length)

Effective Size= 44.6"W x 30.0"H => 6.45 sf x 7.12'L = 45.9 cf

Overall Size= 51.0"W x 30.0"H x 7.56'L with 0.44' Overlap

51.0" Wide + 6.0" Spacing = 57.0" C-C Row Spacing

5 Chambers/Row x 7.12' Long +0.81' Cap Length x 2 = 37.22' Row Length +12.0" End Stone x 2 = 39.22' Base Length

5 Rows x 51.0" Wide + 6.0" Spacing x 4 + 12.0" Side Stone x 2 = 25.25' Base Width

6.0" Base + 30.0" Chamber Height + 8.0" Cover = 3.67' Field Height

25 Chambers x 45.9 cf = 1,148.5 cf Chamber Storage

3,630.8 cf Field - 1,148.5 cf Chambers = 2,482.3 cf Stone x 30.0% Voids = 744.7 cf Stone Storage

Chamber Storage + Stone Storage = 1,893.2 cf = 0.043 af

Overall Storage Efficiency = 52.1%

Overall System Size = 39.22' x 25.25' x 3.67'

25 Chambers

134.5 cy Field

91.9 cy Stone

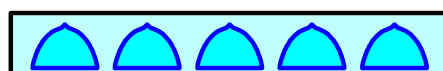
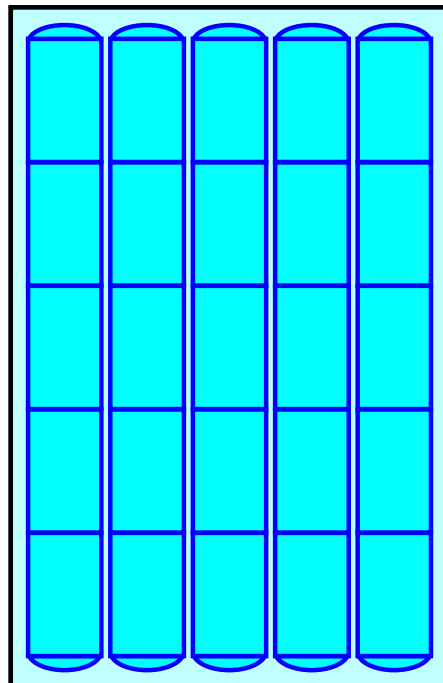

Pond UG-2: Pond 2A and 2B - Chamber Wizard Field B

Chamber Model = ADS_StormTechSC-740 +Cap (ADS StormTech®SC-740 with cap length)

Effective Size= 44.6"W x 30.0"H => 6.45 sf x 7.12'L = 45.9 cf

Overall Size= 51.0"W x 30.0"H x 7.56'L with 0.44' Overlap

51.0" Wide + 6.0" Spacing = 57.0" C-C Row Spacing

7 Chambers/Row x 7.12' Long +0.81' Cap Length x 2 = 51.46' Row Length +12.0" End Stone x 2 = 53.46' Base Length

5 Rows x 51.0" Wide + 6.0" Spacing x 4 + 12.0" Side Stone x 2 = 25.25' Base Width

6.0" Base + 30.0" Chamber Height + 8.0" Cover = 3.67' Field Height

35 Chambers x 45.9 cf = 1,607.9 cf Chamber Storage

4,949.2 cf Field - 1,607.9 cf Chambers = 3,341.3 cf Stone x 30.0% Voids = 1,002.4 cf Stone Storage

Chamber Storage + Stone Storage = 2,610.3 cf = 0.060 af

Overall Storage Efficiency = 52.7%

Overall System Size = 53.46' x 25.25' x 3.67'

35 Chambers

183.3 cy Field

123.8 cy Stone

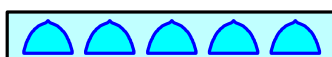
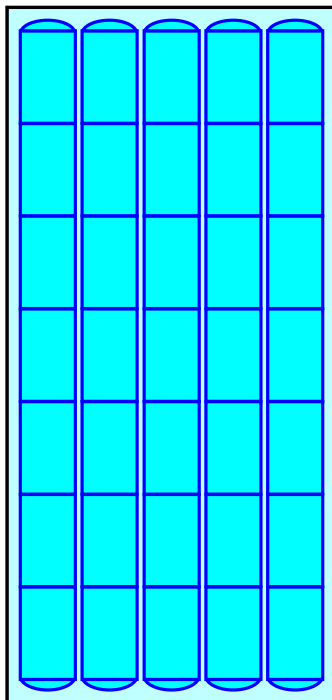

Pond UG-2: Pond 2A and 2B

Hydrograph

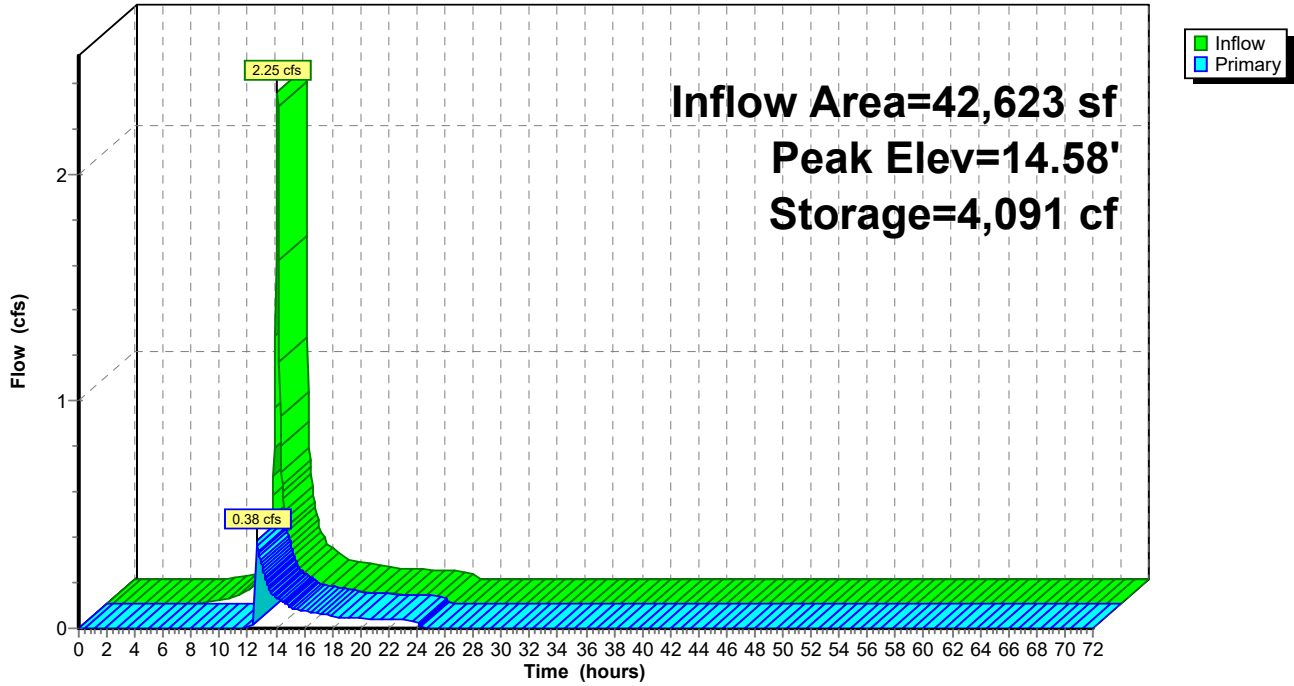

13569drainage-ex-pr

NOAA 24-hr D 10-Year Rainfall=5.14"

Prepared by Nitsch Engineering

Printed 4/14/2021

HydroCAD® 10.00-20 s/n 00546 © 2017 HydroCAD Software Solutions LLC

Page 16

Time span=0.00-72.00 hrs, dt=0.05 hrs, 1441 points
Runoff by SCS TR-20 method, UH=SCS, Weighted-CN
Reach routing by Stor-Ind+Trans method - Pond routing by Stor-Ind method

SubcatchmentDA-1: Pedestrian Area and Runoff Area=42,623 sf 59.01% Impervious Runoff Depth=3.80"
Tc=6.0 min CN=88 Runoff=4.06 cfs 13,505 cf

SubcatchmentDA-2: Building and ParkingRunoff Area=133,279 sf 91.74% Impervious Runoff Depth=4.67"
Tc=6.0 min CN=96 Runoff=14.32 cfs 51,887 cf

SubcatchmentDA-3: Porous Pavement Runoff Area=14,085 sf 100.00% Impervious Runoff Depth=4.90"
Tc=60.0 min CN=98 Runoff=0.60 cfs 5,755 cf

Reach 1R: DP-PR Inflow=18.28 cfs 65,336 cf
Outflow=18.28 cfs 65,336 cf

Pond PP: Porous Pavement Peak Elev=14.67' Storage=2,484 cf Inflow=0.60 cfs 5,755 cf
Outflow=0.49 cfs 3,980 cf

Pond UG-2: Pond 2A and 2B Peak Elev=14.90' Storage=4,313 cf Inflow=4.06 cfs 13,505 cf
Outflow=4.00 cfs 9,469 cf

Total Runoff Area = 189,987 sf Runoff Volume = 71,146 cf Average Runoff Depth = 4.49"
14.99% Pervious = 28,474 sf 85.01% Impervious = 161,513 sf

Summary for Subcatchment DA-1: Pedestrian Area and Landscaping

Runoff = 4.06 cfs @ 12.13 hrs, Volume= 13,505 cf, Depth= 3.80"

Runoff by SCS TR-20 method, UH=SCS, Weighted-CN, Time Span= 0.00-72.00 hrs, dt= 0.05 hrs
 NOAA 24-hr D 10-Year Rainfall=5.14"

Area (sf)	CN	Description
17,470	74	>75% Grass cover, Good, HSG C
* 25,153	98	Slte Impervious
42,623	88	Weighted Average
17,470		40.99% Pervious Area
25,153		59.01% Impervious Area

Tc (min)	Length (feet)	Slope (ft/ft)	Velocity (ft/sec)	Capacity (cfs)	Description
6.0					Direct Entry,

Subcatchment DA-1: Pedestrian Area and Landscaping

Hydrograph

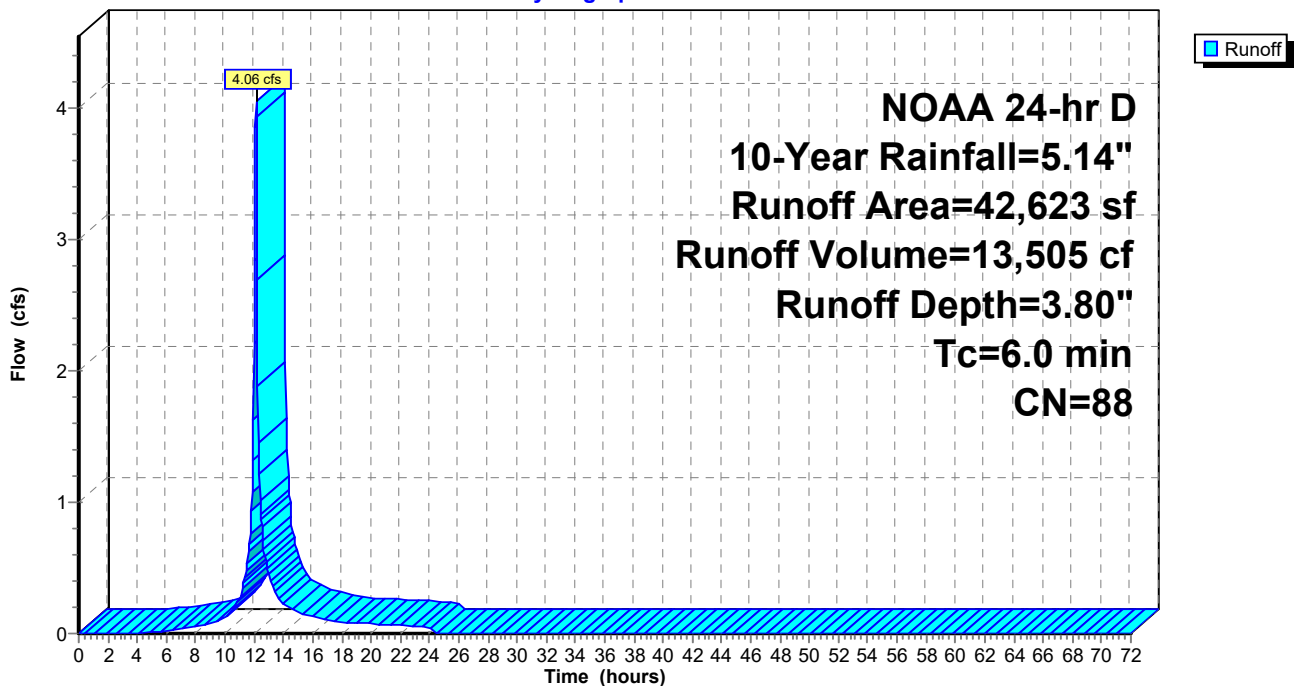

Summary for Subcatchment DA-2: Building and Parking

Runoff = 14.32 cfs @ 12.13 hrs, Volume= 51,887 cf, Depth= 4.67"

Runoff by SCS TR-20 method, UH=SCS, Weighted-CN, Time Span= 0.00-72.00 hrs, dt= 0.05 hrs
 NOAA 24-hr D 10-Year Rainfall=5.14"

Area (sf)	CN	Description
11,004	74	>75% Grass cover, Good, HSG C
68,629	98	Paved parking, HSG C
53,646	98	Roofs, HSG C
133,279	96	Weighted Average
11,004		8.26% Pervious Area
122,275		91.74% Impervious Area

Tc (min)	Length (feet)	Slope (ft/ft)	Velocity (ft/sec)	Capacity (cfs)	Description
6.0					Direct Entry,

Subcatchment DA-2: Building and Parking

Hydrograph

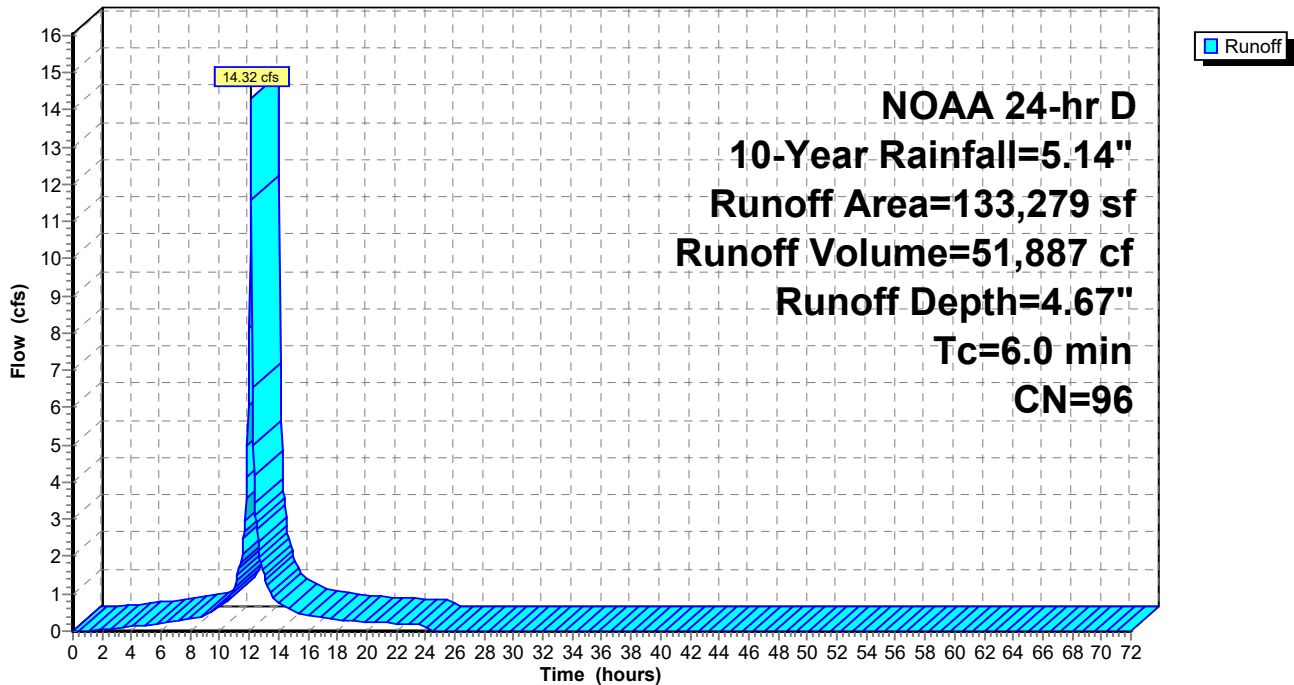

Summary for Subcatchment DA-3: Porous Pavement

Runoff = 0.60 cfs @ 12.77 hrs, Volume= 5,755 cf, Depth= 4.90"

Runoff by SCS TR-20 method, UH=SCS, Weighted-CN, Time Span= 0.00-72.00 hrs, dt= 0.05 hrs
 NOAA 24-hr D 10-Year Rainfall=5.14"

Area (sf)	CN	Description
* 14,085	98	Porous Asphalt
14,085		100.00% Impervious Area

Tc (min)	Length (feet)	Slope (ft/ft)	Velocity (ft/sec)	Capacity (cfs)	Description
60.0					Direct Entry,

Subcatchment DA-3: Porous Pavement

Hydrograph

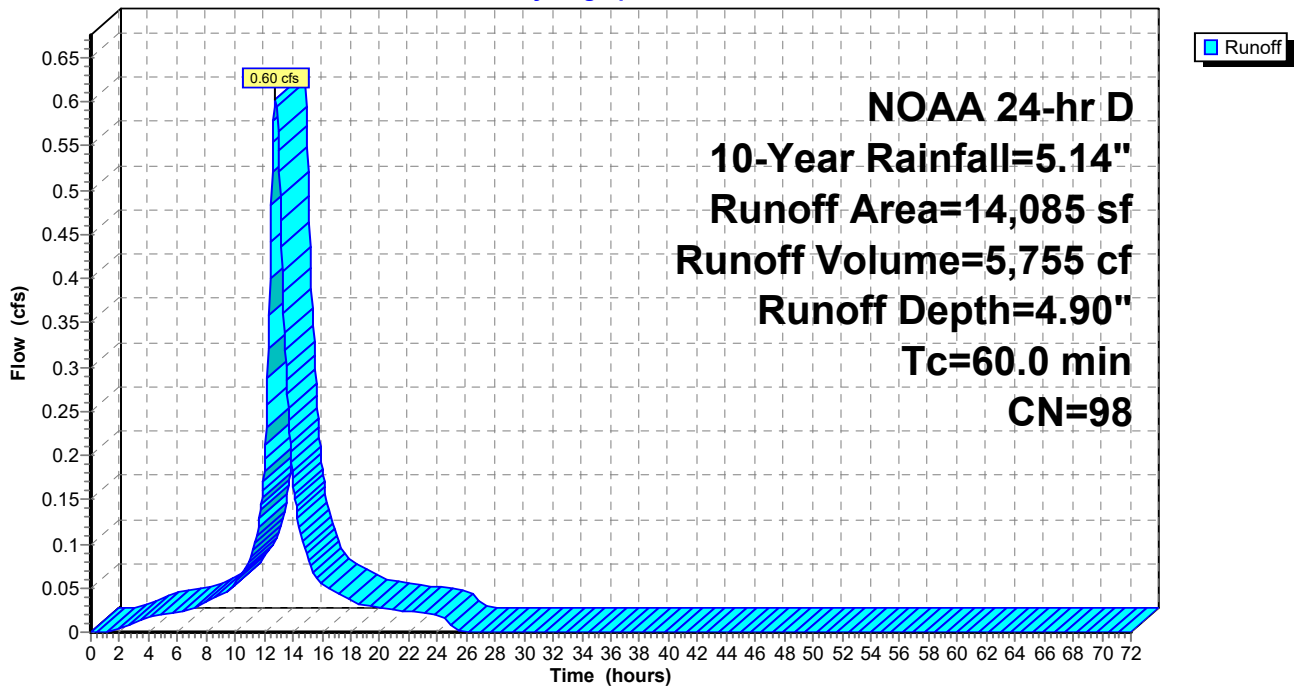

Summary for Reach 1R: DP-PR

[40] Hint: Not Described (Outflow=Inflow)

Inflow Area = 189,987 sf, 85.01% Impervious, Inflow Depth = 4.13" for 10-Year event
Inflow = 18.28 cfs @ 12.13 hrs, Volume= 65,336 cf
Outflow = 18.28 cfs @ 12.13 hrs, Volume= 65,336 cf, Atten= 0%, Lag= 0.0 min

Routing by Stor-Ind+Trans method, Time Span= 0.00-72.00 hrs, dt= 0.05 hrs

Reach 1R: DP-PR

Hydrograph

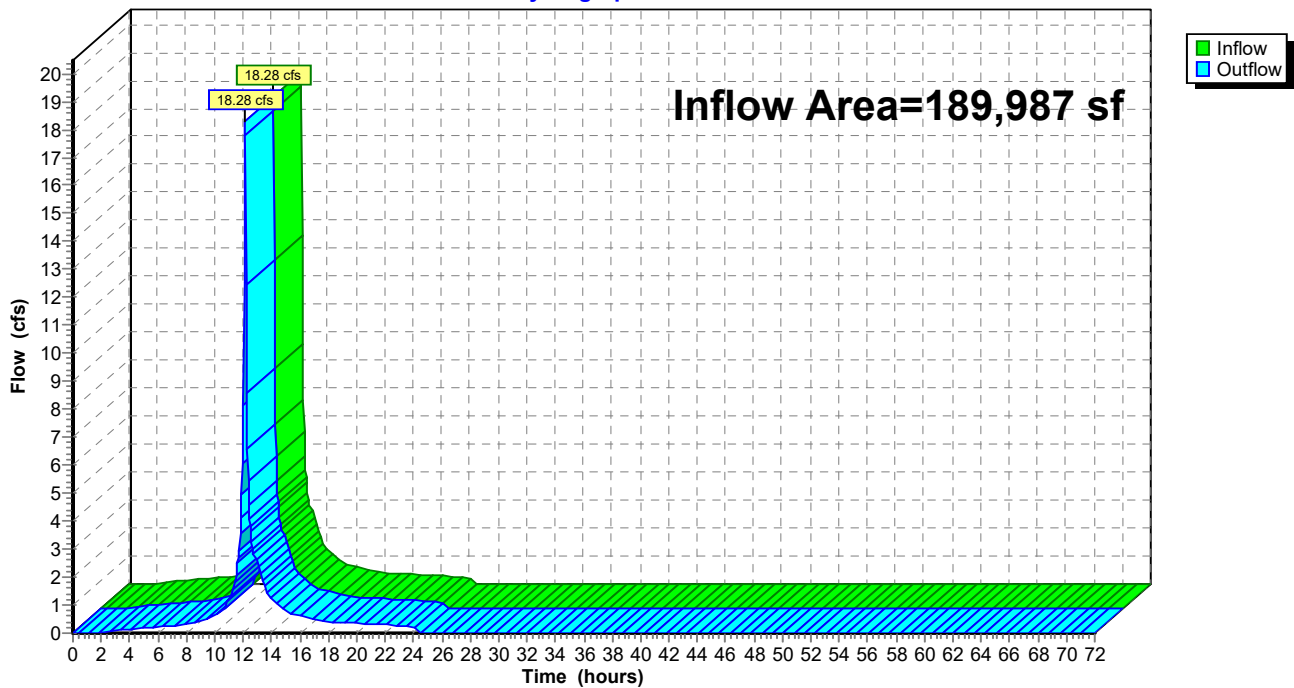

Summary for Pond PP: Porous Pavement

Inflow Area = 14,085 sf, 100.00% Impervious, Inflow Depth = 4.90" for 10-Year event
 Inflow = 0.60 cfs @ 12.77 hrs, Volume= 5,755 cf
 Outflow = 0.49 cfs @ 13.11 hrs, Volume= 3,980 cf, Atten= 18%, Lag= 20.0 min
 Primary = 0.49 cfs @ 13.11 hrs, Volume= 3,980 cf

Routing by Stor-Ind method, Time Span= 0.00-72.00 hrs, dt= 0.05 hrs
 Peak Elev= 14.67' @ 13.11 hrs Surf.Area= 14,085 sf Storage= 2,484 cf

Plug-Flow detention time= 255.0 min calculated for 3,980 cf (69% of inflow)
 Center-of-Mass det. time= 146.8 min (945.7 - 798.9)

Volume	Invert	Avail.Storage	Storage Description
#1	16.33'	479 cf	4" Pervious Pavement (Prismatic) Listed below (Recalc) 4,789 cf Overall x 10.0% Voids
#2	16.00'	1,394 cf	4" Choker Course (Prismatic) Listed below (Recalc) 4,648 cf Overall x 30.0% Voids
#3	15.33'	2,831 cf	8" Filter Course (Prismatic) Listed below (Recalc) 9,437 cf Overall x 30.0% Voids
#4	15.08'	1,056 cf	3" Filter Blanket (Prismatic) Listed below (Recalc) 3,521 cf Overall x 30.0% Voids
#5	14.08'	4,226 cf	12" Reservoir (Prismatic) Listed below (Recalc) 14,085 cf Overall x 30.0% Voids
		9,986 cf	Total Available Storage

Elevation (feet)	Surf.Area (sq-ft)	Inc.Store (cubic-feet)	Cum.Store (cubic-feet)
16.33	14,085	0	0
16.67	14,085	4,789	4,789

Elevation (feet)	Surf.Area (sq-ft)	Inc.Store (cubic-feet)	Cum.Store (cubic-feet)
16.00	14,085	0	0
16.33	14,085	4,648	4,648

Elevation (feet)	Surf.Area (sq-ft)	Inc.Store (cubic-feet)	Cum.Store (cubic-feet)
15.33	14,085	0	0
16.00	14,085	9,437	9,437

Elevation (feet)	Surf.Area (sq-ft)	Inc.Store (cubic-feet)	Cum.Store (cubic-feet)
15.08	14,085	0	0
15.33	14,085	3,521	3,521

Elevation (feet)	Surf.Area (sq-ft)	Inc.Store (cubic-feet)	Cum.Store (cubic-feet)
14.08	14,085	0	0
15.08	14,085	14,085	14,085

Device	Routing	Invert	Outlet Devices
#1	Primary	14.50'	4.0" Vert. Orifice/Grate X 8.00 C= 0.600

Primary OutFlow Max=0.49 cfs @ 13.11 hrs HW=14.67' (Free Discharge)
↑1=Orifice/Grate (Orifice Controls 0.49 cfs @ 1.39 fps)

Pond PP: Porous Pavement

Hydrograph

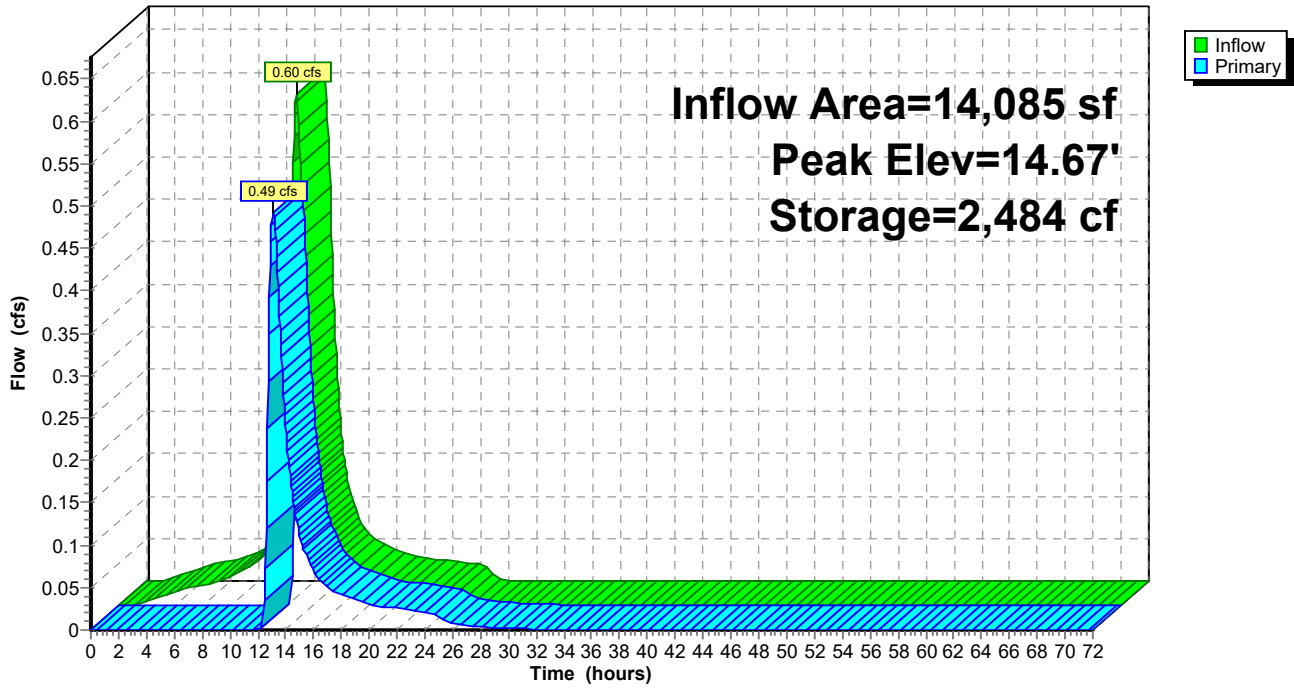

Summary for Pond UG-2: Pond 2A and 2B

Inflow Area = 42,623 sf, 59.01% Impervious, Inflow Depth = 3.80" for 10-Year event
 Inflow = 4.06 cfs @ 12.13 hrs, Volume= 13,505 cf
 Outflow = 4.00 cfs @ 12.14 hrs, Volume= 9,469 cf, Atten= 1%, Lag= 0.7 min
 Primary = 4.00 cfs @ 12.14 hrs, Volume= 9,469 cf

Routing by Stor-Ind method, Time Span= 0.00-72.00 hrs, dt= 0.05 hrs
 Peak Elev= 14.90' @ 12.14 hrs Surf.Area= 2,340 sf Storage= 4,313 cf

Plug-Flow detention time= 170.1 min calculated for 9,463 cf (70% of inflow)
 Center-of-Mass det. time= 69.6 min (872.7 - 803.1)

Volume	Invert	Avail.Storage	Storage Description
#1A	11.50'	745 cf	25.25"W x 39.22"L x 3.67'H Field A 3,631 cf Overall - 1,149 cf Embedded = 2,482 cf x 30.0% Voids
#2A	12.00'	1,149 cf	ADS_StormTech SC-740 +Cap x 25 Inside #1 Effective Size= 44.6"W x 30.0"H => 6.45 sf x 7.12'L = 45.9 cf Overall Size= 51.0"W x 30.0"H x 7.56'L with 0.44' Overlap 5 Rows of 5 Chambers
#3B	11.50'	1,002 cf	25.25"W x 53.46"L x 3.67'H Field B 4,949 cf Overall - 1,608 cf Embedded = 3,341 cf x 30.0% Voids
#4B	12.00'	1,608 cf	ADS_StormTech SC-740 +Cap x 35 Inside #3 Effective Size= 44.6"W x 30.0"H => 6.45 sf x 7.12'L = 45.9 cf Overall Size= 51.0"W x 30.0"H x 7.56'L with 0.44' Overlap 5 Rows of 7 Chambers
		4,503 cf	Total Available Storage

Storage Group A created with Chamber Wizard
 Storage Group B created with Chamber Wizard

Device	Routing	Invert	Outlet Devices
#1	Primary	14.50'	5.0' long Sharp-Crested Rectangular Weir 2 End Contraction(s)

Primary OutFlow Max=3.89 cfs @ 12.14 hrs HW=14.89' (Free Discharge)
 ↑1=Sharp-Crested Rectangular Weir (Weir Controls 3.89 cfs @ 2.04 fps)

Pond UG-2: Pond 2A and 2B - Chamber Wizard Field A

Chamber Model = ADS_StormTechSC-740 +Cap (ADS StormTech®SC-740 with cap length)

Effective Size= 44.6"W x 30.0"H => 6.45 sf x 7.12'L = 45.9 cf

Overall Size= 51.0"W x 30.0"H x 7.56'L with 0.44' Overlap

51.0" Wide + 6.0" Spacing = 57.0" C-C Row Spacing

5 Chambers/Row x 7.12' Long +0.81' Cap Length x 2 = 37.22' Row Length +12.0" End Stone x 2 = 39.22' Base Length

5 Rows x 51.0" Wide + 6.0" Spacing x 4 + 12.0" Side Stone x 2 = 25.25' Base Width

6.0" Base + 30.0" Chamber Height + 8.0" Cover = 3.67' Field Height

25 Chambers x 45.9 cf = 1,148.5 cf Chamber Storage

3,630.8 cf Field - 1,148.5 cf Chambers = 2,482.3 cf Stone x 30.0% Voids = 744.7 cf Stone Storage

Chamber Storage + Stone Storage = 1,893.2 cf = 0.043 af

Overall Storage Efficiency = 52.1%

Overall System Size = 39.22' x 25.25' x 3.67'

25 Chambers

134.5 cy Field

91.9 cy Stone

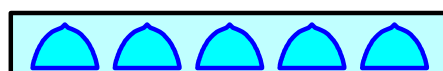
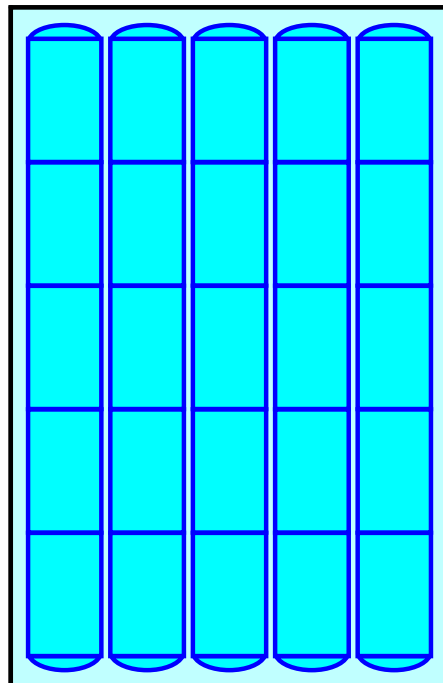

Pond UG-2: Pond 2A and 2B - Chamber Wizard Field B

Chamber Model = ADS_StormTechSC-740 +Cap (ADS StormTech®SC-740 with cap length)

Effective Size= 44.6"W x 30.0"H => 6.45 sf x 7.12'L = 45.9 cf

Overall Size= 51.0"W x 30.0"H x 7.56'L with 0.44' Overlap

51.0" Wide + 6.0" Spacing = 57.0" C-C Row Spacing

7 Chambers/Row x 7.12' Long +0.81' Cap Length x 2 = 51.46' Row Length +12.0" End Stone x 2 = 53.46' Base Length

5 Rows x 51.0" Wide + 6.0" Spacing x 4 + 12.0" Side Stone x 2 = 25.25' Base Width

6.0" Base + 30.0" Chamber Height + 8.0" Cover = 3.67' Field Height

35 Chambers x 45.9 cf = 1,607.9 cf Chamber Storage

4,949.2 cf Field - 1,607.9 cf Chambers = 3,341.3 cf Stone x 30.0% Voids = 1,002.4 cf Stone Storage

Chamber Storage + Stone Storage = 2,610.3 cf = 0.060 af

Overall Storage Efficiency = 52.7%

Overall System Size = 53.46' x 25.25' x 3.67'

35 Chambers

183.3 cy Field

123.8 cy Stone

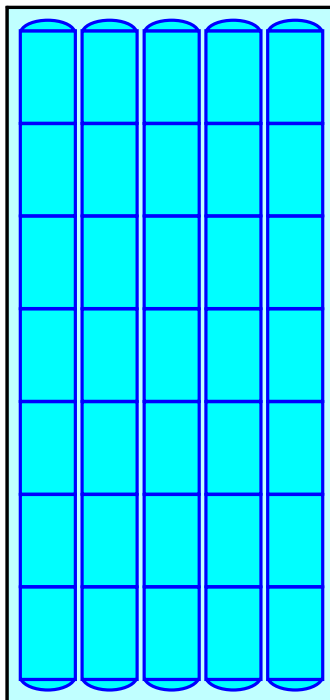

Pond UG-2: Pond 2A and 2B

Hydrograph

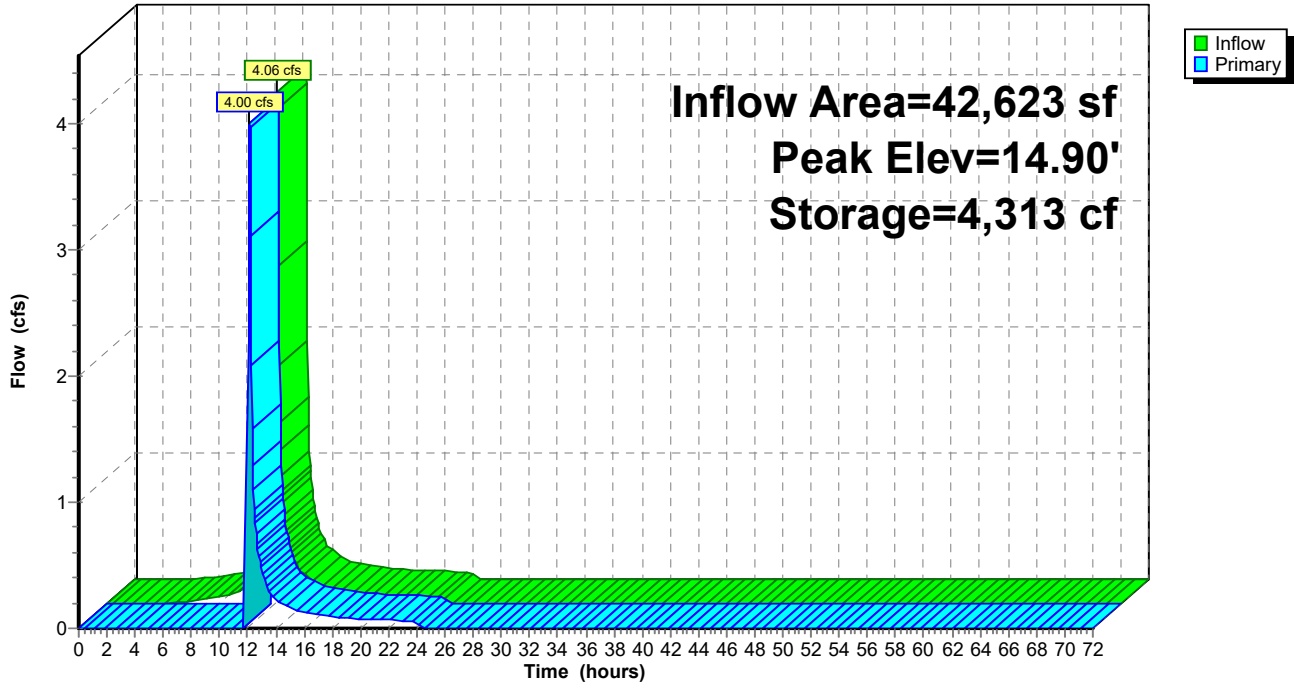

13569drainage-ex-pr

NOAA 24-hr D 25-Year Rainfall=6.32"

Prepared by Nitsch Engineering

Printed 4/14/2021

HydroCAD® 10.00-20 s/n 00546 © 2017 HydroCAD Software Solutions LLC

Page 27

Time span=0.00-72.00 hrs, dt=0.05 hrs, 1441 points
Runoff by SCS TR-20 method, UH=SCS, Weighted-CN
Reach routing by Stor-Ind+Trans method - Pond routing by Stor-Ind method

SubcatchmentDA-1: Pedestrian Area and Runoff Area=42,623 sf 59.01% Impervious Runoff Depth=4.93"
Tc=6.0 min CN=88 Runoff=5.18 cfs 17,527 cf

SubcatchmentDA-2: Building and ParkingRunoff Area=133,279 sf 91.74% Impervious Runoff Depth=5.85"
Tc=6.0 min CN=96 Runoff=17.71 cfs 64,930 cf

SubcatchmentDA-3: Porous Pavement Runoff Area=14,085 sf 100.00% Impervious Runoff Depth=6.08"
Tc=60.0 min CN=98 Runoff=0.74 cfs 7,138 cf

Reach 1R: DP-PR Inflow=22.81 cfs 83,785 cf
Outflow=22.81 cfs 83,785 cf

Pond PP: Porous Pavement Peak Elev=14.70' Storage=2,618 cf Inflow=0.74 cfs 7,138 cf
Outflow=0.66 cfs 5,363 cf

Pond UG-2: Pond 2A and 2B Peak Elev=14.97' Storage=4,364 cf Inflow=5.18 cfs 17,527 cf
Outflow=5.14 cfs 13,492 cf

Total Runoff Area = 189,987 sf Runoff Volume = 89,595 cf Average Runoff Depth = 5.66"
14.99% Pervious = 28,474 sf 85.01% Impervious = 161,513 sf

Summary for Subcatchment DA-1: Pedestrian Area and Landscaping

Runoff = 5.18 cfs @ 12.13 hrs, Volume= 17,527 cf, Depth= 4.93"

Runoff by SCS TR-20 method, UH=SCS, Weighted-CN, Time Span= 0.00-72.00 hrs, dt= 0.05 hrs
 NOAA 24-hr D 25-Year Rainfall=6.32"

Area (sf)	CN	Description
17,470	74	>75% Grass cover, Good, HSG C
* 25,153	98	Slte Impervious
42,623	88	Weighted Average
17,470		40.99% Pervious Area
25,153		59.01% Impervious Area

Tc (min)	Length (feet)	Slope (ft/ft)	Velocity (ft/sec)	Capacity (cfs)	Description
6.0					Direct Entry,

Subcatchment DA-1: Pedestrian Area and Landscaping

Hydrograph

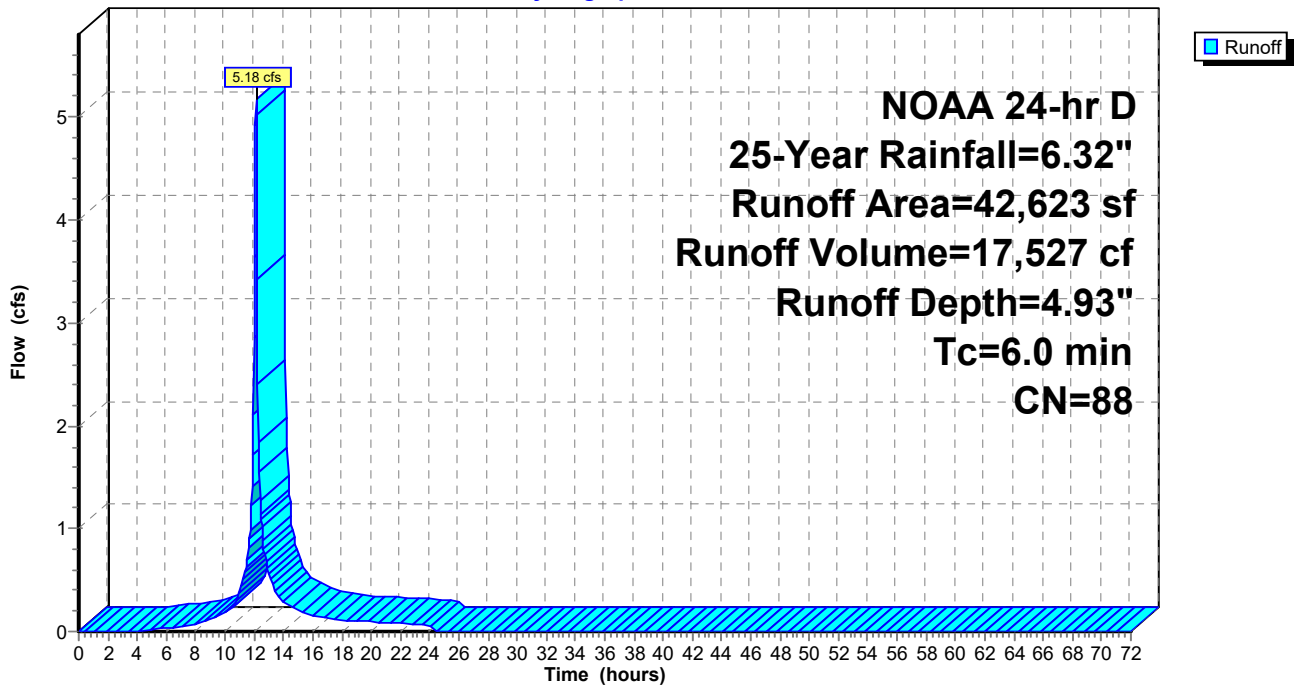

Summary for Subcatchment DA-2: Building and Parking

Runoff = 17.71 cfs @ 12.13 hrs, Volume= 64,930 cf, Depth= 5.85"

Runoff by SCS TR-20 method, UH=SCS, Weighted-CN, Time Span= 0.00-72.00 hrs, dt= 0.05 hrs
 NOAA 24-hr D 25-Year Rainfall=6.32"

Area (sf)	CN	Description
11,004	74	>75% Grass cover, Good, HSG C
68,629	98	Paved parking, HSG C
53,646	98	Roofs, HSG C
133,279	96	Weighted Average
11,004		8.26% Pervious Area
122,275		91.74% Impervious Area

Tc (min)	Length (feet)	Slope (ft/ft)	Velocity (ft/sec)	Capacity (cfs)	Description
6.0					Direct Entry,

Subcatchment DA-2: Building and Parking

Hydrograph

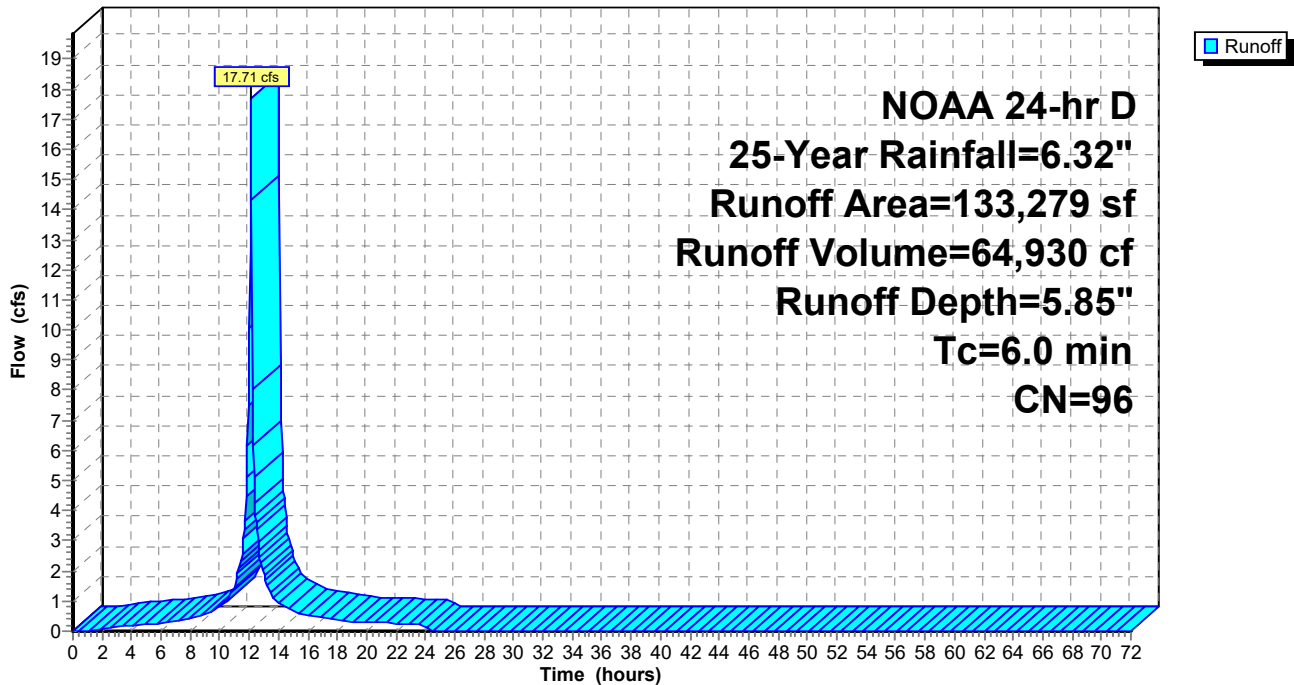

Summary for Subcatchment DA-3: Porous Pavement

Runoff = 0.74 cfs @ 12.77 hrs, Volume= 7,138 cf, Depth= 6.08"

Runoff by SCS TR-20 method, UH=SCS, Weighted-CN, Time Span= 0.00-72.00 hrs, dt= 0.05 hrs
 NOAA 24-hr D 25-Year Rainfall=6.32"

Area (sf)	CN	Description
* 14,085	98	Porous Asphalt
14,085		100.00% Impervious Area

Tc (min)	Length (feet)	Slope (ft/ft)	Velocity (ft/sec)	Capacity (cfs)	Description
60.0					Direct Entry,

Subcatchment DA-3: Porous Pavement

Hydrograph

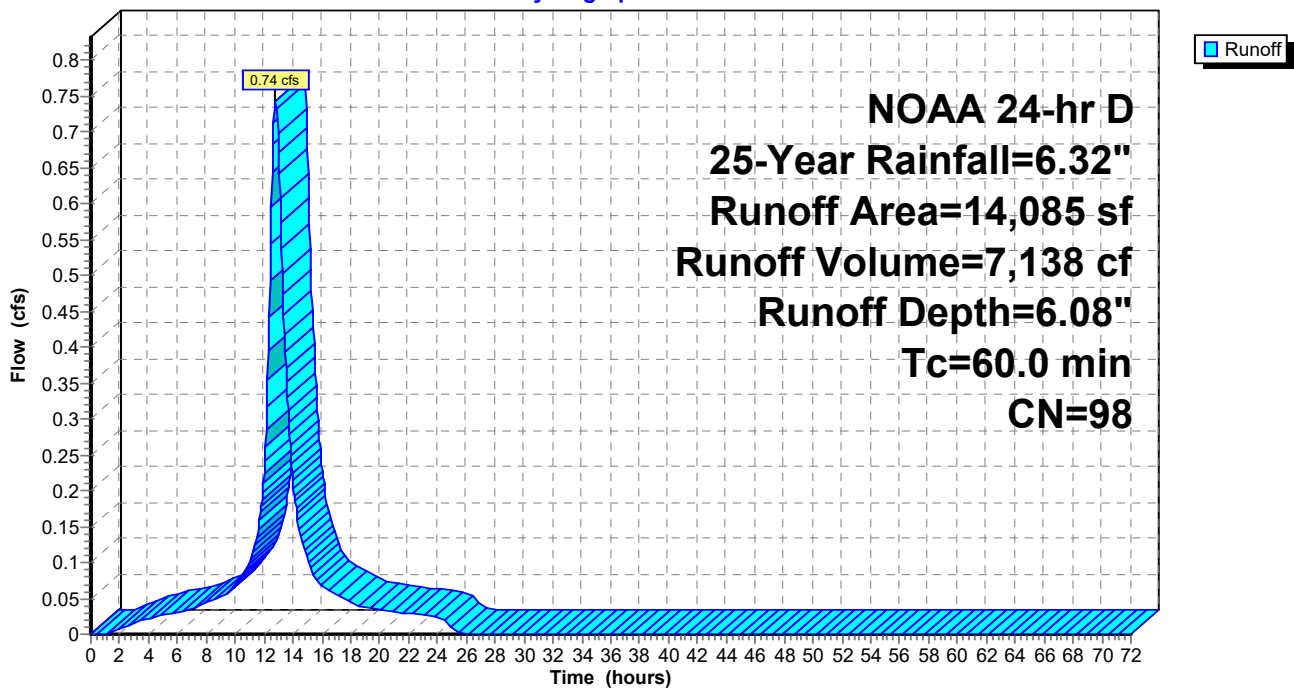

Summary for Reach 1R: DP-PR

[40] Hint: Not Described (Outflow=Inflow)

Inflow Area = 189,987 sf, 85.01% Impervious, Inflow Depth = 5.29" for 25-Year event
Inflow = 22.81 cfs @ 12.13 hrs, Volume= 83,785 cf
Outflow = 22.81 cfs @ 12.13 hrs, Volume= 83,785 cf, Atten= 0%, Lag= 0.0 min

Routing by Stor-Ind+Trans method, Time Span= 0.00-72.00 hrs, dt= 0.05 hrs

Reach 1R: DP-PR

Hydrograph

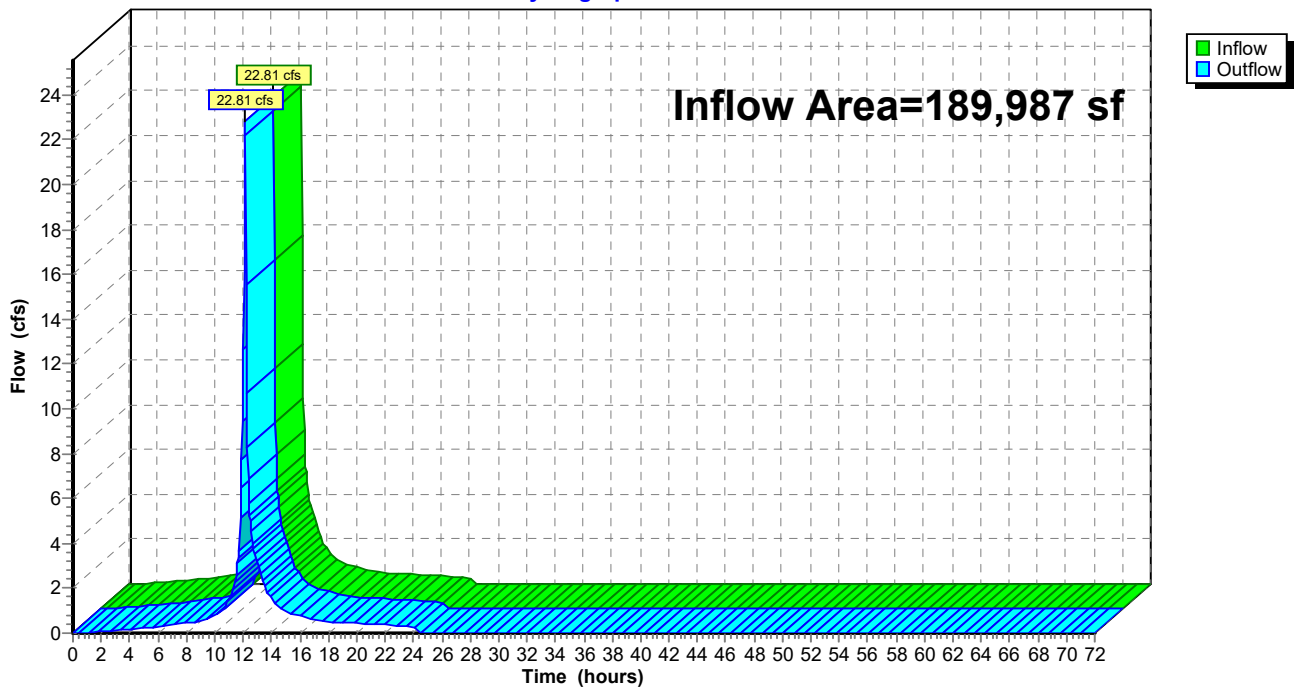

Summary for Pond PP: Porous Pavement

Inflow Area = 14,085 sf, 100.00% Impervious, Inflow Depth = 6.08" for 25-Year event
 Inflow = 0.74 cfs @ 12.77 hrs, Volume= 7,138 cf
 Outflow = 0.66 cfs @ 13.01 hrs, Volume= 5,363 cf, Atten= 11%, Lag= 14.6 min
 Primary = 0.66 cfs @ 13.01 hrs, Volume= 5,363 cf

Routing by Stor-Ind method, Time Span= 0.00-72.00 hrs, dt= 0.05 hrs
 Peak Elev= 14.70' @ 13.01 hrs Surf.Area= 14,085 sf Storage= 2,618 cf

Plug-Flow detention time= 225.0 min calculated for 5,360 cf (75% of inflow)
 Center-of-Mass det. time= 129.7 min (925.2 - 795.5)

Volume	Invert	Avail.Storage	Storage Description
#1	16.33'	479 cf	4" Pervious Pavement (Prismatic) Listed below (Recalc) 4,789 cf Overall x 10.0% Voids
#2	16.00'	1,394 cf	4" Choker Course (Prismatic) Listed below (Recalc) 4,648 cf Overall x 30.0% Voids
#3	15.33'	2,831 cf	8" Filter Course (Prismatic) Listed below (Recalc) 9,437 cf Overall x 30.0% Voids
#4	15.08'	1,056 cf	3" Filter Blanket (Prismatic) Listed below (Recalc) 3,521 cf Overall x 30.0% Voids
#5	14.08'	4,226 cf	12" Reservoir (Prismatic) Listed below (Recalc) 14,085 cf Overall x 30.0% Voids
		9,986 cf	Total Available Storage

Elevation (feet)	Surf.Area (sq-ft)	Inc.Store (cubic-feet)	Cum.Store (cubic-feet)
16.33	14,085	0	0
16.67	14,085	4,789	4,789

Elevation (feet)	Surf.Area (sq-ft)	Inc.Store (cubic-feet)	Cum.Store (cubic-feet)
16.00	14,085	0	0
16.33	14,085	4,648	4,648

Elevation (feet)	Surf.Area (sq-ft)	Inc.Store (cubic-feet)	Cum.Store (cubic-feet)
15.33	14,085	0	0
16.00	14,085	9,437	9,437

Elevation (feet)	Surf.Area (sq-ft)	Inc.Store (cubic-feet)	Cum.Store (cubic-feet)
15.08	14,085	0	0
15.33	14,085	3,521	3,521

Elevation (feet)	Surf.Area (sq-ft)	Inc.Store (cubic-feet)	Cum.Store (cubic-feet)
14.08	14,085	0	0
15.08	14,085	14,085	14,085

Device	Routing	Invert	Outlet Devices
#1	Primary	14.50'	4.0" Vert. Orifice/Grate X 8.00 C= 0.600

Primary OutFlow Max=0.66 cfs @ 13.01 hrs HW=14.70' (Free Discharge)
↑1=Orifice/Grate (Orifice Controls 0.66 cfs @ 1.52 fps)

Pond PP: Porous Pavement

Hydrograph

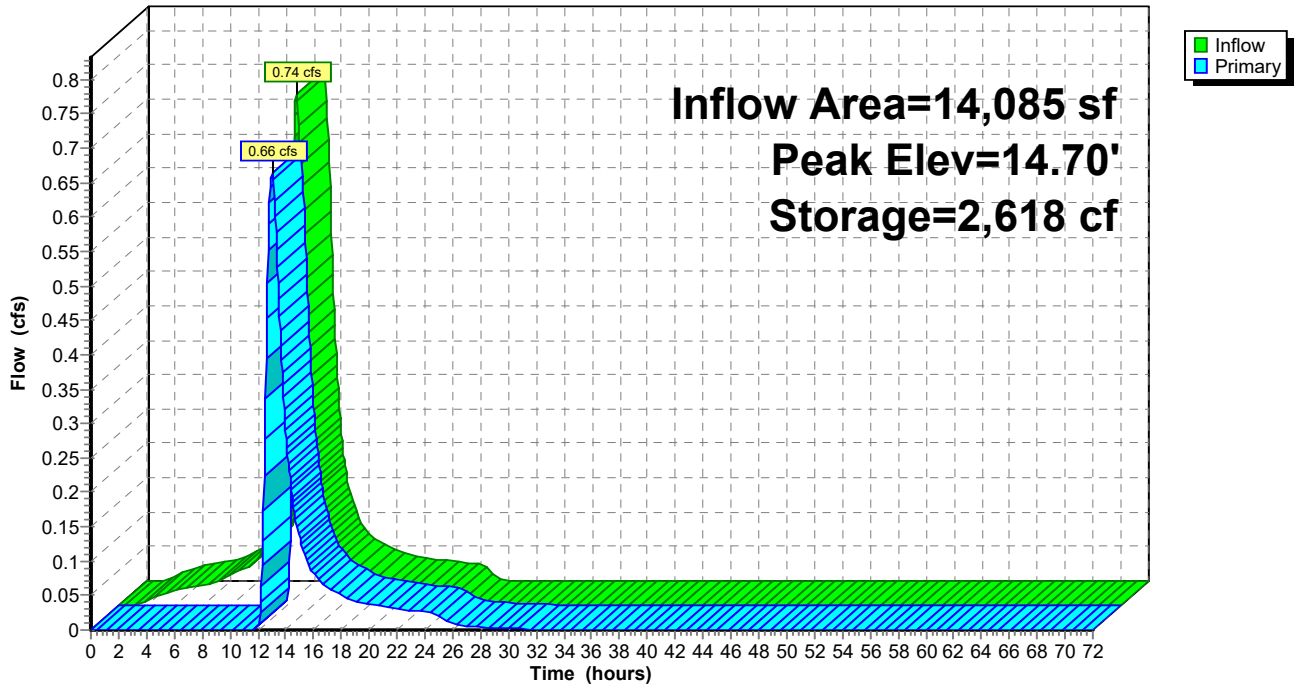

Summary for Pond UG-2: Pond 2A and 2B

Inflow Area = 42,623 sf, 59.01% Impervious, Inflow Depth = 4.93" for 25-Year event
 Inflow = 5.18 cfs @ 12.13 hrs, Volume= 17,527 cf
 Outflow = 5.14 cfs @ 12.14 hrs, Volume= 13,492 cf, Atten= 1%, Lag= 0.8 min
 Primary = 5.14 cfs @ 12.14 hrs, Volume= 13,492 cf

Routing by Stor-Ind method, Time Span= 0.00-72.00 hrs, dt= 0.05 hrs
 Peak Elev= 14.97' @ 12.14 hrs Surf.Area= 2,340 sf Storage= 4,364 cf

Plug-Flow detention time= 146.8 min calculated for 13,482 cf (77% of inflow)
 Center-of-Mass det. time= 58.4 min (853.6 - 795.1)

Volume	Invert	Avail.Storage	Storage Description
#1A	11.50'	745 cf	25.25'W x 39.22'L x 3.67'H Field A 3,631 cf Overall - 1,149 cf Embedded = 2,482 cf x 30.0% Voids
#2A	12.00'	1,149 cf	ADS_StormTech SC-740 +Cap x 25 Inside #1 Effective Size= 44.6"W x 30.0"H => 6.45 sf x 7.12'L = 45.9 cf Overall Size= 51.0"W x 30.0"H x 7.56'L with 0.44' Overlap 5 Rows of 5 Chambers
#3B	11.50'	1,002 cf	25.25'W x 53.46'L x 3.67'H Field B 4,949 cf Overall - 1,608 cf Embedded = 3,341 cf x 30.0% Voids
#4B	12.00'	1,608 cf	ADS_StormTech SC-740 +Cap x 35 Inside #3 Effective Size= 44.6"W x 30.0"H => 6.45 sf x 7.12'L = 45.9 cf Overall Size= 51.0"W x 30.0"H x 7.56'L with 0.44' Overlap 5 Rows of 7 Chambers
		4,503 cf	Total Available Storage

Storage Group A created with Chamber Wizard
 Storage Group B created with Chamber Wizard

Device	Routing	Invert	Outlet Devices
#1	Primary	14.50'	5.0' long Sharp-Crested Rectangular Weir 2 End Contraction(s)

Primary OutFlow Max=5.01 cfs @ 12.14 hrs HW=14.96' (Free Discharge)
 ↑1=Sharp-Crested Rectangular Weir(Weir Controls 5.01 cfs @ 2.22 fps)

Pond UG-2: Pond 2A and 2B - Chamber Wizard Field A

Chamber Model = ADS_StormTechSC-740 +Cap (ADS StormTech®SC-740 with cap length)

Effective Size= 44.6"W x 30.0"H => 6.45 sf x 7.12'L = 45.9 cf

Overall Size= 51.0"W x 30.0"H x 7.56'L with 0.44' Overlap

51.0" Wide + 6.0" Spacing = 57.0" C-C Row Spacing

5 Chambers/Row x 7.12' Long +0.81' Cap Length x 2 = 37.22' Row Length +12.0" End Stone x 2 = 39.22' Base Length

5 Rows x 51.0" Wide + 6.0" Spacing x 4 + 12.0" Side Stone x 2 = 25.25' Base Width

6.0" Base + 30.0" Chamber Height + 8.0" Cover = 3.67' Field Height

25 Chambers x 45.9 cf = 1,148.5 cf Chamber Storage

3,630.8 cf Field - 1,148.5 cf Chambers = 2,482.3 cf Stone x 30.0% Voids = 744.7 cf Stone Storage

Chamber Storage + Stone Storage = 1,893.2 cf = 0.043 af

Overall Storage Efficiency = 52.1%

Overall System Size = 39.22' x 25.25' x 3.67'

25 Chambers

134.5 cy Field

91.9 cy Stone

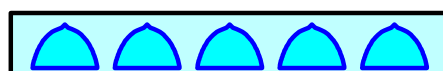
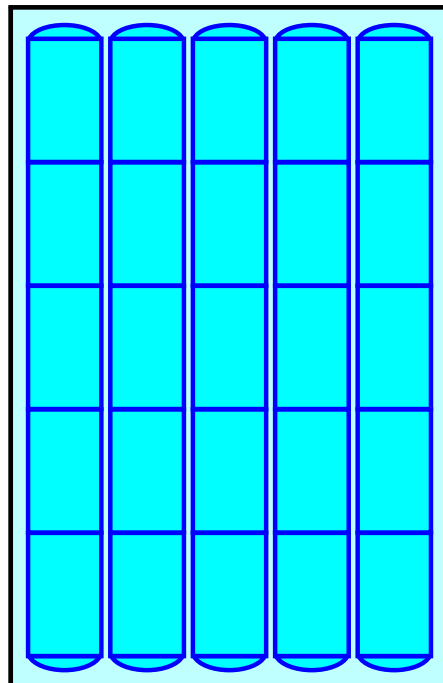

Pond UG-2: Pond 2A and 2B - Chamber Wizard Field B

Chamber Model = ADS_StormTechSC-740 +Cap (ADS StormTech®SC-740 with cap length)

Effective Size= 44.6"W x 30.0"H => 6.45 sf x 7.12'L = 45.9 cf

Overall Size= 51.0"W x 30.0"H x 7.56'L with 0.44' Overlap

51.0" Wide + 6.0" Spacing = 57.0" C-C Row Spacing

7 Chambers/Row x 7.12' Long +0.81' Cap Length x 2 = 51.46' Row Length +12.0" End Stone x 2 = 53.46' Base Length

5 Rows x 51.0" Wide + 6.0" Spacing x 4 + 12.0" Side Stone x 2 = 25.25' Base Width

6.0" Base + 30.0" Chamber Height + 8.0" Cover = 3.67' Field Height

35 Chambers x 45.9 cf = 1,607.9 cf Chamber Storage

4,949.2 cf Field - 1,607.9 cf Chambers = 3,341.3 cf Stone x 30.0% Voids = 1,002.4 cf Stone Storage

Chamber Storage + Stone Storage = 2,610.3 cf = 0.060 af

Overall Storage Efficiency = 52.7%

Overall System Size = 53.46' x 25.25' x 3.67'

35 Chambers

183.3 cy Field

123.8 cy Stone

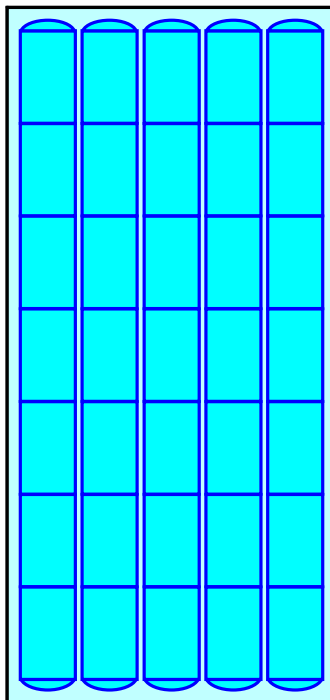

Pond UG-2: Pond 2A and 2B

Hydrograph

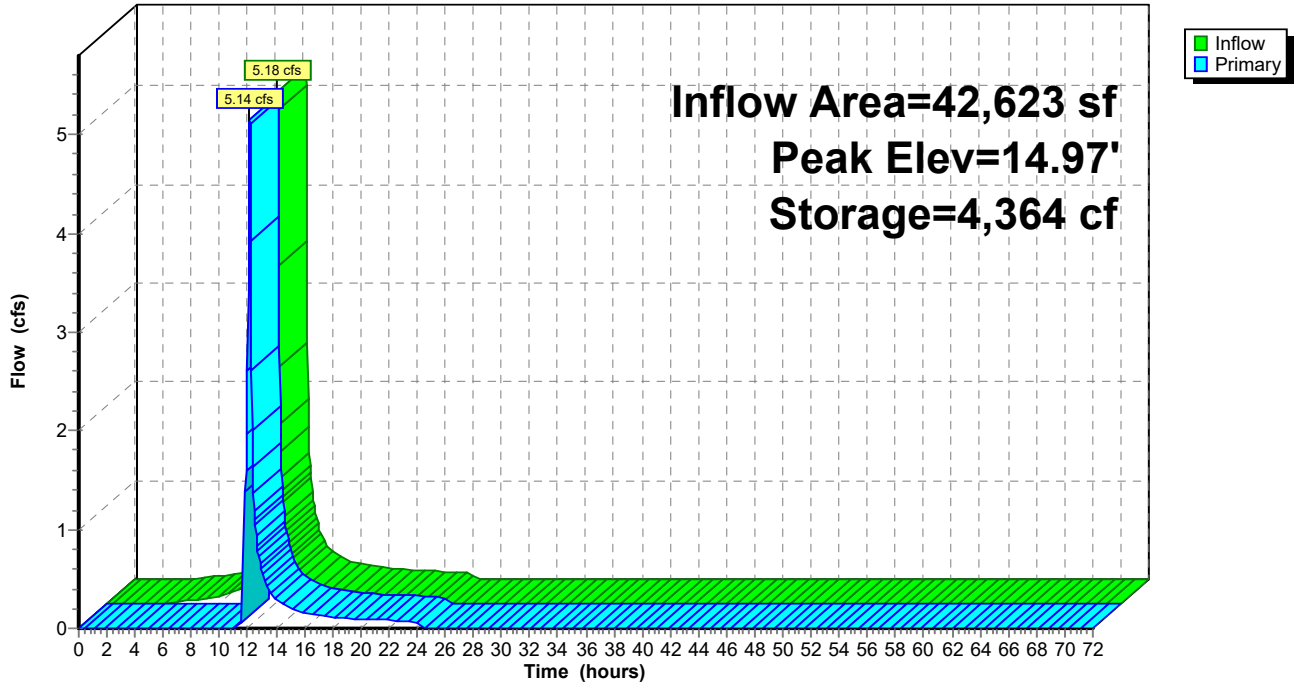

13569drainage-ex-pr

NOAA 24-hr D 100-Year Rainfall=8.14"

Prepared by Nitsch Engineering

Printed 4/14/2021

HydroCAD® 10.00-20 s/n 00546 © 2017 HydroCAD Software Solutions LLC

Page 38

Time span=0.00-72.00 hrs, dt=0.05 hrs, 1441 points
Runoff by SCS TR-20 method, UH=SCS, Weighted-CN
Reach routing by Stor-Ind+Trans method - Pond routing by Stor-Ind method

SubcatchmentDA-1: Pedestrian Area and Runoff Area=42,623 sf 59.01% Impervious Runoff Depth=6.71"
Tc=6.0 min CN=88 Runoff=6.91 cfs 23,816 cf

SubcatchmentDA-2: Building and Parking Runoff Area=133,279 sf 91.74% Impervious Runoff Depth=7.66"
Tc=6.0 min CN=96 Runoff=22.93 cfs 85,082 cf

SubcatchmentDA-3: Porous Pavement Runoff Area=14,085 sf 100.00% Impervious Runoff Depth=7.90"
Tc=60.0 min CN=98 Runoff=0.96 cfs 9,273 cf

Reach 1R: DP-PR Inflow=29.95 cfs 112,360 cf
Outflow=29.95 cfs 112,360 cf

Pond PP: Porous Pavement Peak Elev=14.74' Storage=2,778 cf Inflow=0.96 cfs 9,273 cf
Outflow=0.88 cfs 7,498 cf

Pond UG-2: Pond 2A and 2B Peak Elev=15.07' Storage=4,435 cf Inflow=6.91 cfs 23,816 cf
Outflow=6.87 cfs 19,780 cf

Total Runoff Area = 189,987 sf Runoff Volume = 118,171 cf Average Runoff Depth = 7.46"
14.99% Pervious = 28,474 sf 85.01% Impervious = 161,513 sf

Summary for Subcatchment DA-1: Pedestrian Area and Landscaping

Runoff = 6.91 cfs @ 12.13 hrs, Volume= 23,816 cf, Depth= 6.71"

Runoff by SCS TR-20 method, UH=SCS, Weighted-CN, Time Span= 0.00-72.00 hrs, dt= 0.05 hrs
 NOAA 24-hr D 100-Year Rainfall=8.14"

Area (sf)	CN	Description
17,470	74	>75% Grass cover, Good, HSG C
* 25,153	98	Slte Impervious
42,623	88	Weighted Average
17,470		40.99% Pervious Area
25,153		59.01% Impervious Area

Tc (min)	Length (feet)	Slope (ft/ft)	Velocity (ft/sec)	Capacity (cfs)	Description
6.0					Direct Entry,

Subcatchment DA-1: Pedestrian Area and Landscaping

Hydrograph

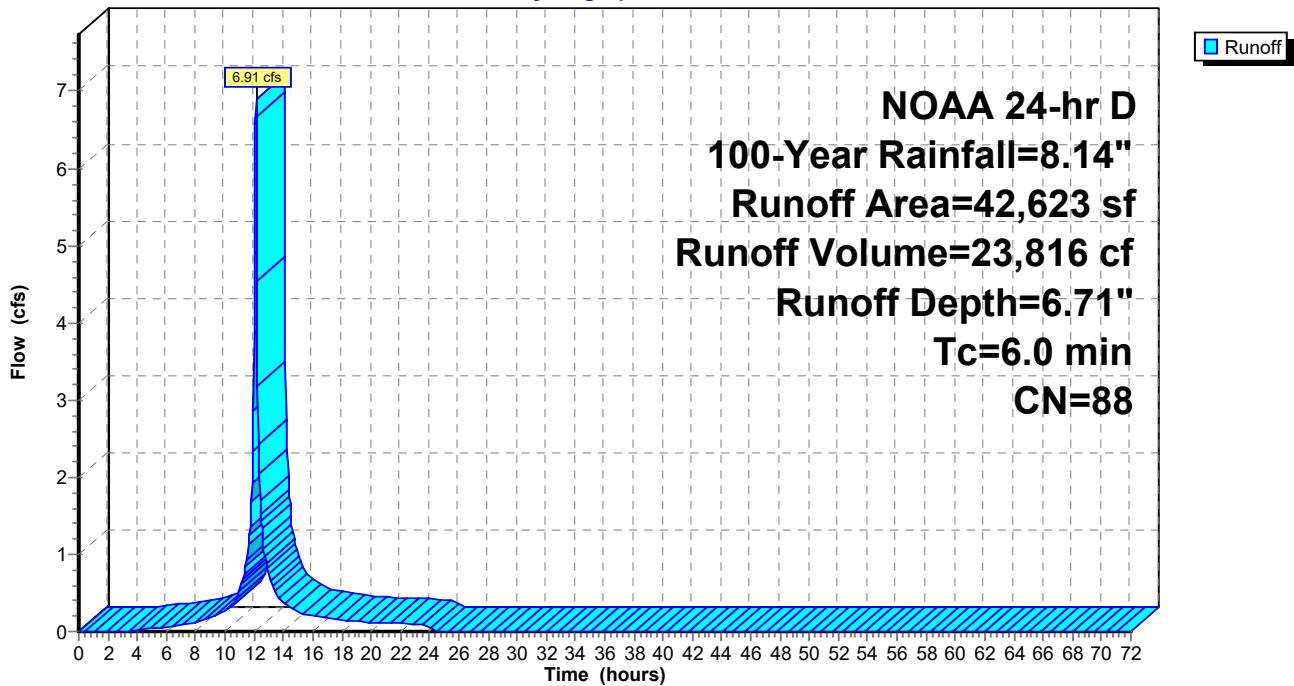

Summary for Subcatchment DA-2: Building and Parking

Runoff = 22.93 cfs @ 12.13 hrs, Volume= 85,082 cf, Depth= 7.66"

Runoff by SCS TR-20 method, UH=SCS, Weighted-CN, Time Span= 0.00-72.00 hrs, dt= 0.05 hrs
 NOAA 24-hr D 100-Year Rainfall=8.14"

Area (sf)	CN	Description
11,004	74	>75% Grass cover, Good, HSG C
68,629	98	Paved parking, HSG C
53,646	98	Roofs, HSG C
133,279	96	Weighted Average
11,004		8.26% Pervious Area
122,275		91.74% Impervious Area

Tc (min)	Length (feet)	Slope (ft/ft)	Velocity (ft/sec)	Capacity (cfs)	Description
6.0					Direct Entry,

Subcatchment DA-2: Building and Parking

Hydrograph

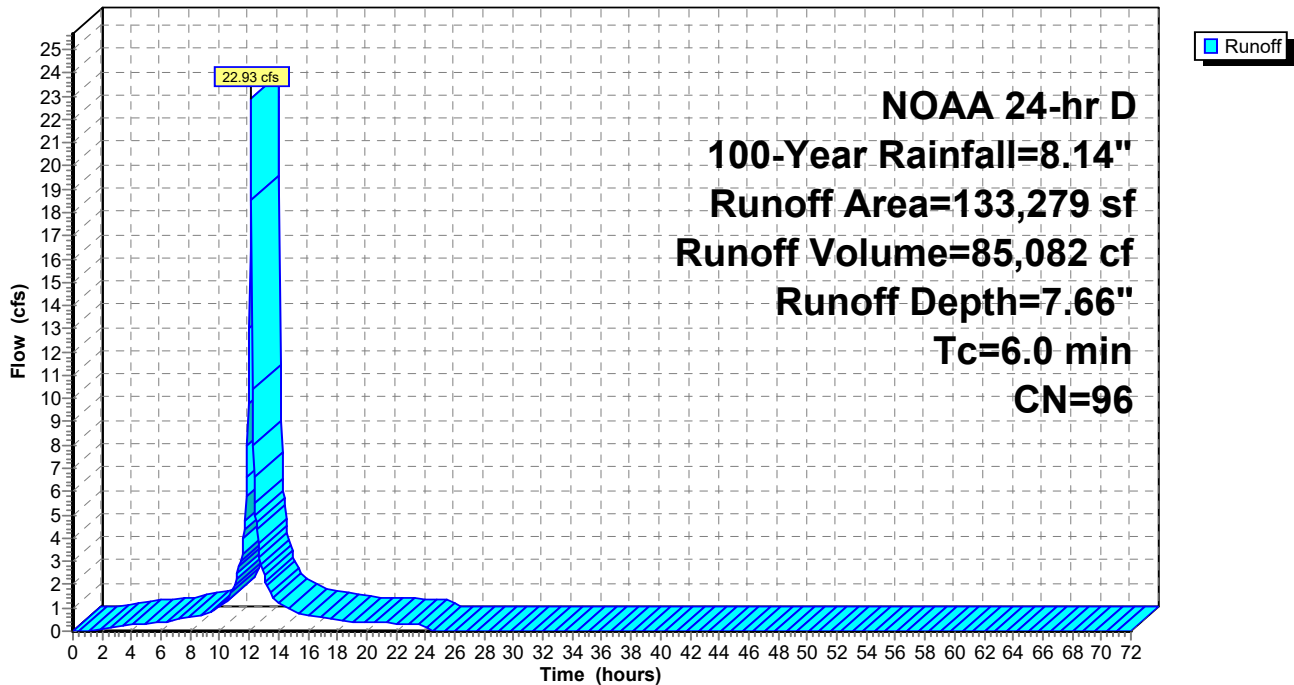

Summary for Subcatchment DA-3: Porous Pavement

Runoff = 0.96 cfs @ 12.77 hrs, Volume= 9,273 cf, Depth= 7.90"

Runoff by SCS TR-20 method, UH=SCS, Weighted-CN, Time Span= 0.00-72.00 hrs, dt= 0.05 hrs
 NOAA 24-hr D 100-Year Rainfall=8.14"

Area (sf)	CN	Description
* 14,085	98	Porous Asphalt
14,085		100.00% Impervious Area

Tc (min)	Length (feet)	Slope (ft/ft)	Velocity (ft/sec)	Capacity (cfs)	Description
60.0					Direct Entry,

Subcatchment DA-3: Porous Pavement

Hydrograph

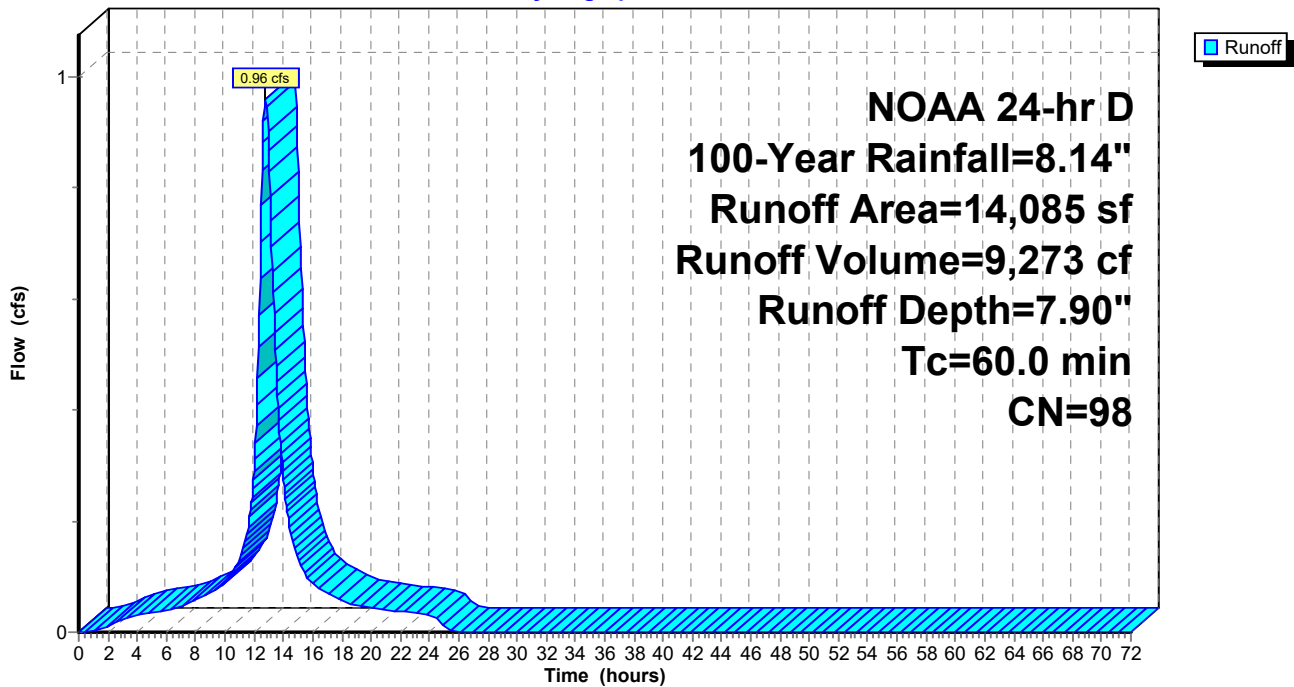

Summary for Reach 1R: DP-PR

[40] Hint: Not Described (Outflow=Inflow)

Inflow Area = 189,987 sf, 85.01% Impervious, Inflow Depth = 7.10" for 100-Year event
Inflow = 29.95 cfs @ 12.13 hrs, Volume= 112,360 cf
Outflow = 29.95 cfs @ 12.13 hrs, Volume= 112,360 cf, Atten= 0%, Lag= 0.0 min

Routing by Stor-Ind+Trans method, Time Span= 0.00-72.00 hrs, dt= 0.05 hrs

Reach 1R: DP-PR

Hydrograph

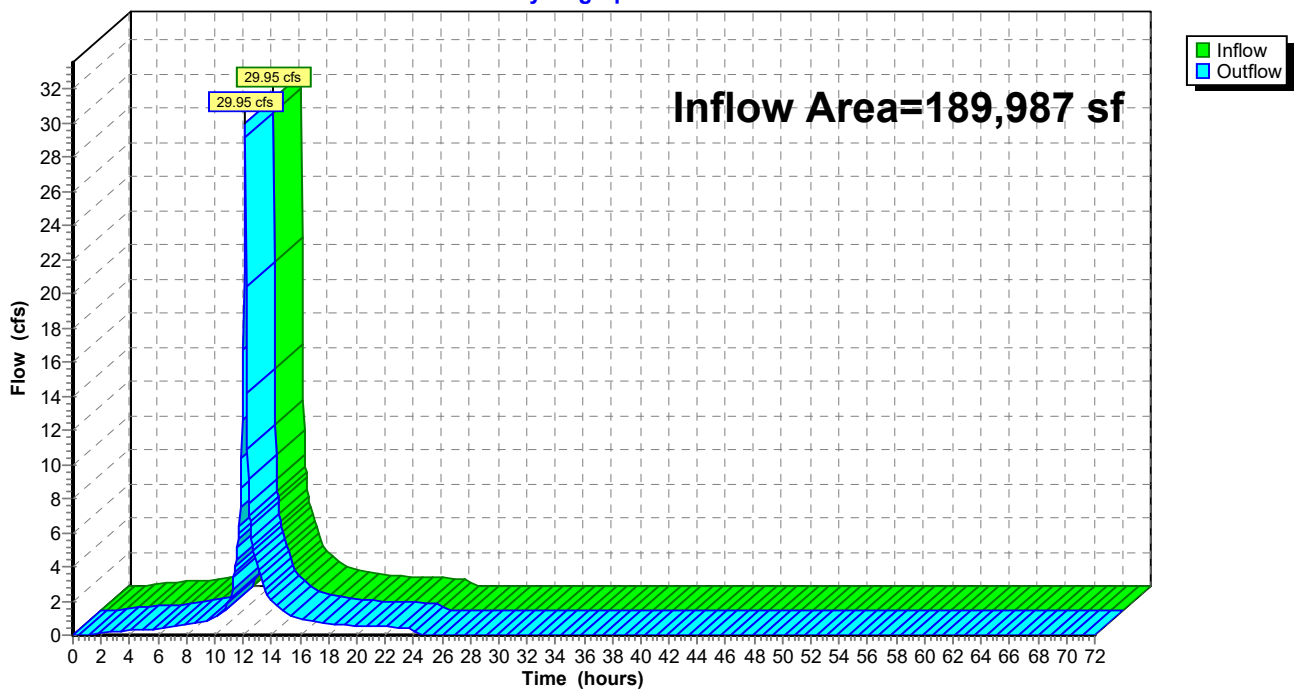

Summary for Pond PP: Porous Pavement

Inflow Area = 14,085 sf, 100.00% Impervious, Inflow Depth = 7.90" for 100-Year event
 Inflow = 0.96 cfs @ 12.77 hrs, Volume= 9,273 cf
 Outflow = 0.88 cfs @ 12.98 hrs, Volume= 7,498 cf, Atten= 8%, Lag= 12.4 min
 Primary = 0.88 cfs @ 12.98 hrs, Volume= 7,498 cf

Routing by Stor-Ind method, Time Span= 0.00-72.00 hrs, dt= 0.05 hrs
 Peak Elev= 14.74' @ 12.98 hrs Surf.Area= 14,085 sf Storage= 2,778 cf

Plug-Flow detention time= 196.2 min calculated for 7,493 cf (81% of inflow)
 Center-of-Mass det. time= 113.6 min (905.6 - 791.9)

Volume	Invert	Avail.Storage	Storage Description
#1	16.33'	479 cf	4" Pervious Pavement (Prismatic) Listed below (Recalc) 4,789 cf Overall x 10.0% Voids
#2	16.00'	1,394 cf	4" Choker Course (Prismatic) Listed below (Recalc) 4,648 cf Overall x 30.0% Voids
#3	15.33'	2,831 cf	8" Filter Course (Prismatic) Listed below (Recalc) 9,437 cf Overall x 30.0% Voids
#4	15.08'	1,056 cf	3" Filter Blanket (Prismatic) Listed below (Recalc) 3,521 cf Overall x 30.0% Voids
#5	14.08'	4,226 cf	12" Reservoir (Prismatic) Listed below (Recalc) 14,085 cf Overall x 30.0% Voids
		9,986 cf	Total Available Storage

Elevation (feet)	Surf.Area (sq-ft)	Inc.Store (cubic-feet)	Cum.Store (cubic-feet)
16.33	14,085	0	0
16.67	14,085	4,789	4,789

Elevation (feet)	Surf.Area (sq-ft)	Inc.Store (cubic-feet)	Cum.Store (cubic-feet)
16.00	14,085	0	0
16.33	14,085	4,648	4,648

Elevation (feet)	Surf.Area (sq-ft)	Inc.Store (cubic-feet)	Cum.Store (cubic-feet)
15.33	14,085	0	0
16.00	14,085	9,437	9,437

Elevation (feet)	Surf.Area (sq-ft)	Inc.Store (cubic-feet)	Cum.Store (cubic-feet)
15.08	14,085	0	0
15.33	14,085	3,521	3,521

Elevation (feet)	Surf.Area (sq-ft)	Inc.Store (cubic-feet)	Cum.Store (cubic-feet)
14.08	14,085	0	0
15.08	14,085	14,085	14,085

Device	Routing	Invert	Outlet Devices
#1	Primary	14.50'	4.0" Vert. Orifice/Grate X 8.00 C= 0.600

Primary OutFlow Max=0.88 cfs @ 12.98 hrs HW=14.74' (Free Discharge)
←1=Orifice/Grate (Orifice Controls 0.88 cfs @ 1.66 fps)

Pond PP: Porous Pavement

Hydrograph

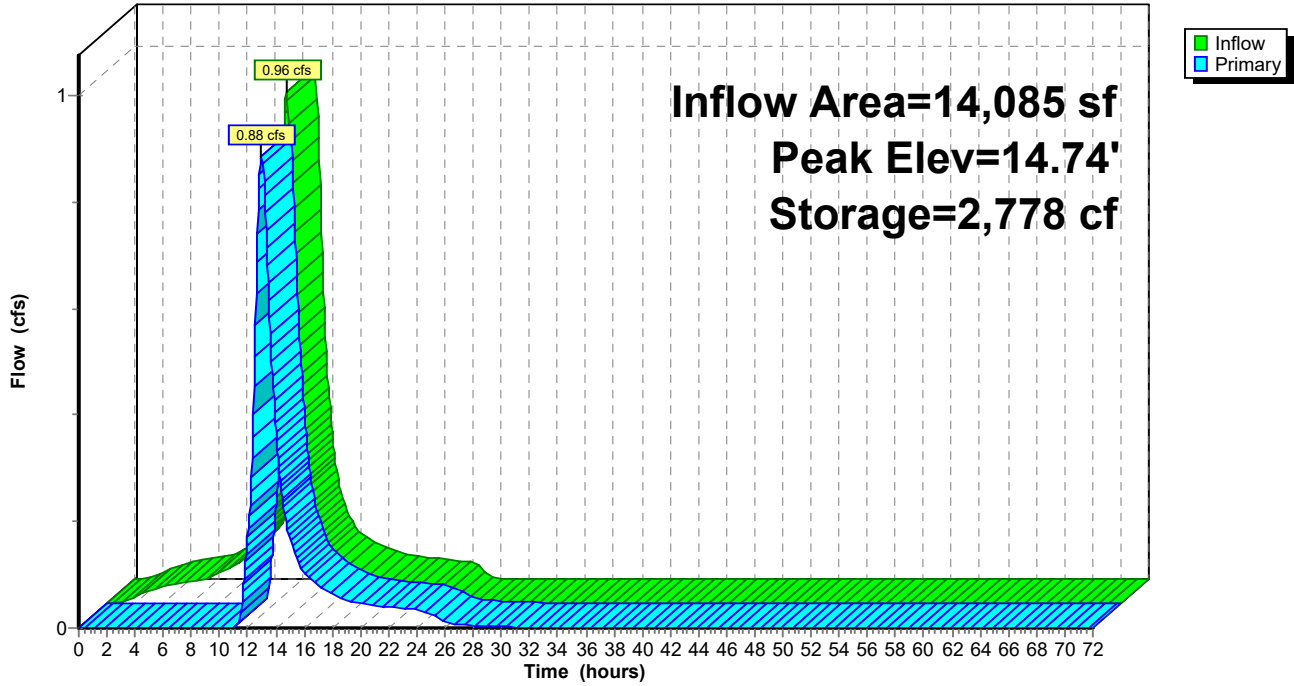

Summary for Pond UG-2: Pond 2A and 2B

Inflow Area = 42,623 sf, 59.01% Impervious, Inflow Depth = 6.71" for 100-Year event
 Inflow = 6.91 cfs @ 12.13 hrs, Volume= 23,816 cf
 Outflow = 6.87 cfs @ 12.14 hrs, Volume= 19,780 cf, Atten= 1%, Lag= 0.8 min
 Primary = 6.87 cfs @ 12.14 hrs, Volume= 19,780 cf

Routing by Stor-Ind method, Time Span= 0.00-72.00 hrs, dt= 0.05 hrs
 Peak Elev= 15.07' @ 12.14 hrs Surf.Area= 2,340 sf Storage= 4,435 cf

Plug-Flow detention time= 125.0 min calculated for 19,780 cf (83% of inflow)
 Center-of-Mass det. time= 50.3 min (836.4 - 786.0)

Volume	Invert	Avail.Storage	Storage Description
#1A	11.50'	745 cf	25.25'W x 39.22'L x 3.67'H Field A 3,631 cf Overall - 1,149 cf Embedded = 2,482 cf x 30.0% Voids
#2A	12.00'	1,149 cf	ADS_StormTech SC-740 +Cap x 25 Inside #1 Effective Size= 44.6"W x 30.0"H => 6.45 sf x 7.12'L = 45.9 cf Overall Size= 51.0"W x 30.0"H x 7.56'L with 0.44' Overlap 5 Rows of 5 Chambers
#3B	11.50'	1,002 cf	25.25'W x 53.46'L x 3.67'H Field B 4,949 cf Overall - 1,608 cf Embedded = 3,341 cf x 30.0% Voids
#4B	12.00'	1,608 cf	ADS_StormTech SC-740 +Cap x 35 Inside #3 Effective Size= 44.6"W x 30.0"H => 6.45 sf x 7.12'L = 45.9 cf Overall Size= 51.0"W x 30.0"H x 7.56'L with 0.44' Overlap 5 Rows of 7 Chambers
		4,503 cf	Total Available Storage

Storage Group A created with Chamber Wizard
 Storage Group B created with Chamber Wizard

Device	Routing	Invert	Outlet Devices
#1	Primary	14.50'	5.0' long Sharp-Crested Rectangular Weir 2 End Contraction(s)

Primary OutFlow Max=6.67 cfs @ 12.14 hrs HW=15.06' (Free Discharge)
 ↑1=Sharp-Crested Rectangular Weir (Weir Controls 6.67 cfs @ 2.44 fps)

Pond UG-2: Pond 2A and 2B - Chamber Wizard Field A

Chamber Model = ADS_StormTechSC-740 +Cap (ADS StormTech®SC-740 with cap length)

Effective Size= 44.6"W x 30.0"H => 6.45 sf x 7.12'L = 45.9 cf

Overall Size= 51.0"W x 30.0"H x 7.56'L with 0.44' Overlap

51.0" Wide + 6.0" Spacing = 57.0" C-C Row Spacing

5 Chambers/Row x 7.12' Long +0.81' Cap Length x 2 = 37.22' Row Length +12.0" End Stone x 2 = 39.22' Base Length

5 Rows x 51.0" Wide + 6.0" Spacing x 4 + 12.0" Side Stone x 2 = 25.25' Base Width

6.0" Base + 30.0" Chamber Height + 8.0" Cover = 3.67' Field Height

25 Chambers x 45.9 cf = 1,148.5 cf Chamber Storage

3,630.8 cf Field - 1,148.5 cf Chambers = 2,482.3 cf Stone x 30.0% Voids = 744.7 cf Stone Storage

Chamber Storage + Stone Storage = 1,893.2 cf = 0.043 af

Overall Storage Efficiency = 52.1%

Overall System Size = 39.22' x 25.25' x 3.67'

25 Chambers

134.5 cy Field

91.9 cy Stone

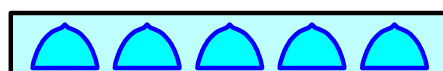
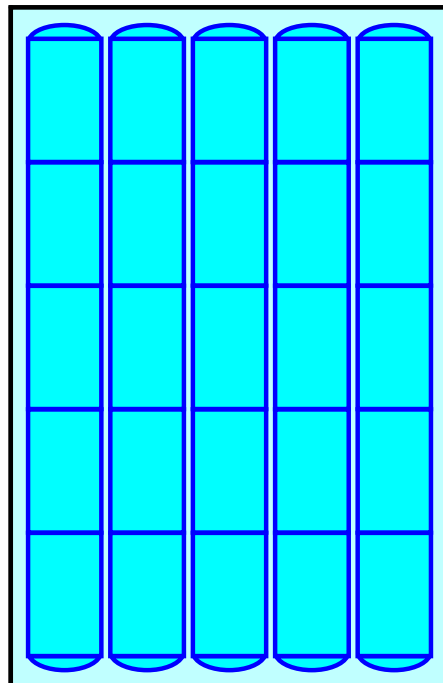

Pond UG-2: Pond 2A and 2B - Chamber Wizard Field B

Chamber Model = ADS_StormTechSC-740 +Cap (ADS StormTech®SC-740 with cap length)

Effective Size= 44.6"W x 30.0"H => 6.45 sf x 7.12'L = 45.9 cf

Overall Size= 51.0"W x 30.0"H x 7.56'L with 0.44' Overlap

51.0" Wide + 6.0" Spacing = 57.0" C-C Row Spacing

7 Chambers/Row x 7.12' Long +0.81' Cap Length x 2 = 51.46' Row Length +12.0" End Stone x 2 = 53.46' Base Length

5 Rows x 51.0" Wide + 6.0" Spacing x 4 + 12.0" Side Stone x 2 = 25.25' Base Width

6.0" Base + 30.0" Chamber Height + 8.0" Cover = 3.67' Field Height

35 Chambers x 45.9 cf = 1,607.9 cf Chamber Storage

4,949.2 cf Field - 1,607.9 cf Chambers = 3,341.3 cf Stone x 30.0% Voids = 1,002.4 cf Stone Storage

Chamber Storage + Stone Storage = 2,610.3 cf = 0.060 af

Overall Storage Efficiency = 52.7%

Overall System Size = 53.46' x 25.25' x 3.67'

35 Chambers

183.3 cy Field

123.8 cy Stone

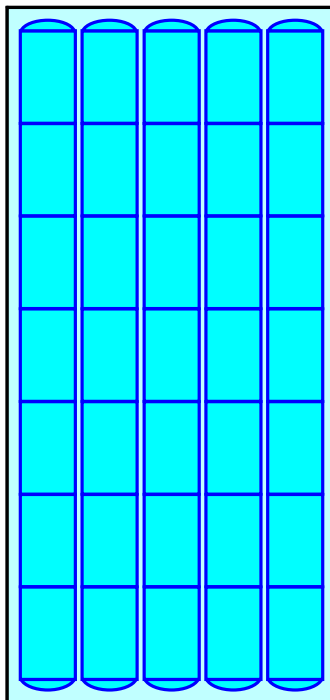

Pond UG-2: Pond 2A and 2B

Hydrograph

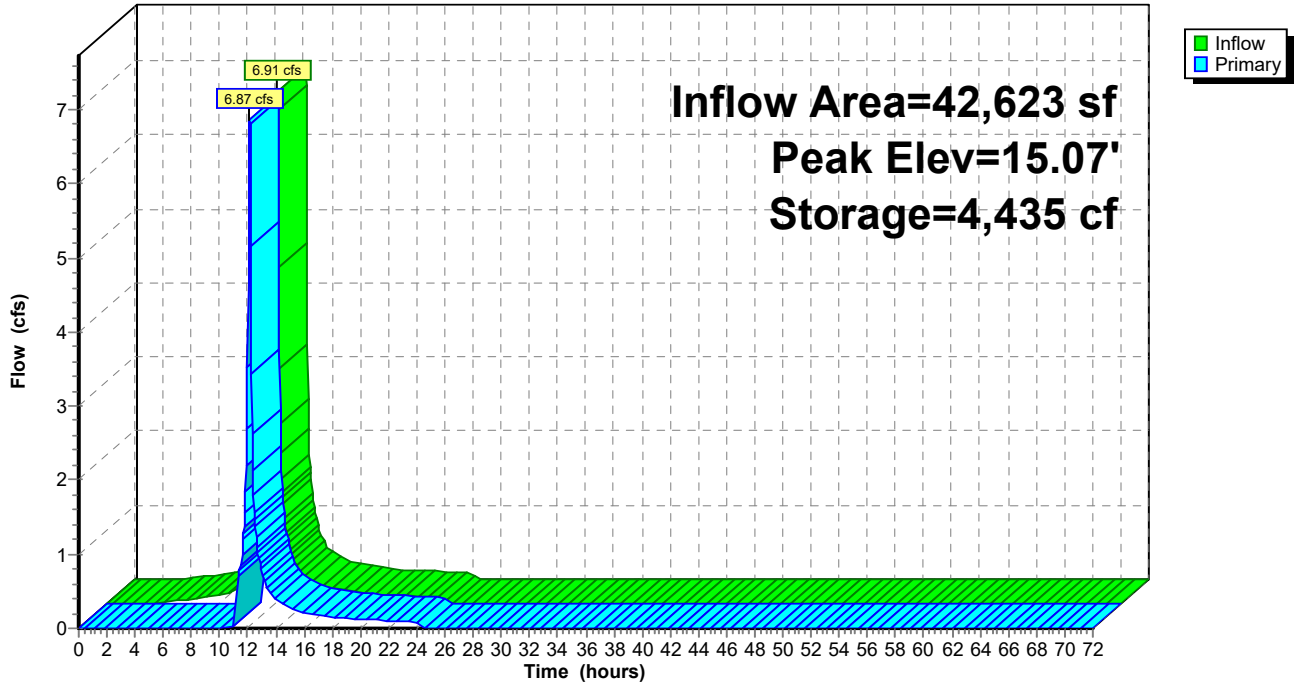

APPENDIX D

Closed Drainage System Design

Storm and Sanitary Analysis Methodology Statement

The Rational Method for Closed Drainage System Design

The Rational Method is a widely accepted rainfall-runoff model used for estimating peak design flows when modeling closed drainage system hydraulics. It is typically used when analyzing runoff rates from drainage areas to individual catch basins due to its simplicity and advantages on smaller scales over other models. Nitsch Engineering used the Rational Method for the project stormwater calculations to estimate the runoff into catch basins and the closed drainage system.

The general formula for the rational method is:

$$Q = C i A$$

where

- Q = *volumetric rate of runoff, in cubic feet per second*
- C = *dimensionless runoff coefficient*
- i = *peak rainfall intensity, in inches per hour*
- A = *contributing drainage area (subcatchment), in acres*

The volumetric flow rate Q at which the runoff reaches a catch basin or other drainage inlet is determined by a number of factors: the slope and flow lengths of the subcatchment area, the soil type, the surface cover and size of the subcatchment area, and the chosen rainfall return period and associated intensity.

Drainage Areas

A drainage area, or subcatchment, is a portion of land that contributes runoff to a catch basin, inlet or other design point. This design point is the focus of the runoff analysis for that individual subcatchment and is considered to be the outflow point for the subcatchment. Peak rates of runoff are calculated at this point and then used to model the receiving pipe network hydraulics to determine pipe sizes, rates of flow, and velocities.

The Runoff Coefficient

The dimensionless runoff coefficient C is determined from a number of factors which are generally related to the surface cover of each individual subcatchment. Surface cover on a site is defined as impervious or pervious and can take the form of lawn, roof, pavement, brush, woods, etc.

Certain types of cover create more opportunities for water to be absorbed into the ground. A site covered with impermeable surfaces, such as pavement, typically has a runoff coefficient of 0.90. This value implies that almost all of the rain that falls on pavement or other impermeable covers will be converted to runoff. A site covered by permeable surfaces, such as grass or other landscaping, will allow some of the water to be absorbed into the ground and can have coefficients which vary from 0.20-0.40 reflecting the associated reduction of runoff due to absorption. These different cover types within a drainage area are assigned a runoff coefficient and then weighted to determine an overall drainage area runoff coefficient C for each subcatchment.

Flow Length and Time of Concentration

As rainfall lands on a portion of the drainage area and produces runoff, this runoff must travel to across the surface to the point of discharge, such as a catch basin, before contributing to the closed drainage hydraulic model. To achieve a maximum flow rate from a subcatchment using the Rational Method, all portions of a drainage area must first contribute to the discharge point. This point in time is known as the *time of concentration*, and is determined by identifying the longest flow path of a watershed with respect to the time of travel. To do this, Nitsch Engineering reviewed several factors of each watershed, including slope, surface cover type, and length and types of flow. As is standard practice, the analysis assumes a minimum time of concentration of six minutes for any subcatchment.

The type of surface along the runoff flow path affects the time of concentration. In general, “smooth” surfaces such as roofs and pavements will offer less resistance to flow allowing for runoff to move more quickly. “Rough” surfaces such as lawns or woods offer more resistance to flow, and therefore runoff typically moves more slowly across these types of surfaces.

In addition, runoff travels across the surface of a drainage area in two types of flow geometry. “Sheet” flow occurs over short distances, typically up to a maximum of fifty feet. Sheet flow is generally very shallow and spreads out across a wide flow path. An example of sheet flow is the runoff between the crown of a roadway to the curb and gutter. Sheet flow eventually gathers together and channelizes into “shallow concentrated” flow which carries runoff more quickly. Flow in the gutter of a road is an example of shallow concentrated flow.

The slope of the shallow concentrated or sheet flow path also affects the travel time. A site with steep slopes will produce more runoff and transport it at a faster rate than a flat site. The slope of the site is easily determined by using an existing conditions survey, proposed grading plans, or by a field examination.

Rainfall Intensity-Duration-Frequency Curves

Rainfall Intensity-Duration-Frequency curves, or IDF curves, describe the probabilistic relationships between average rainfall peak intensities, the duration of the watershed analysis, and the frequency (in years) at which the peak intensity should be expected. *Intensity* of a storm refers to the average rate at which rainfall lands on the surface of a drainage area, typically measured in inches of rainfall per hour. A higher intensity will produce more runoff. For the rational method, *duration* refers to the length of time between the start of the analysis and the point of time when the entire watershed contributes to the discharge point and is equal to time of concentration. A longer duration lowers the intensity value and therefore the peak runoff rate. The *frequency*, or return period, refers to the average number of years between occurrences of a specified peak intensity. For example, if rainfall intensities of equal to or greater than six inches per hour were recorded ten times over a 100-year period, then the return period (frequency) of a 6-inch rainfall would be once every ten years. Put more simply, this is known as a “10-year” storm and has a 1/10, or 10%, statistical chance of occurring during any given year.

IDF curves are important to stormwater designers when developing closed drainage system models. They provide a meaningful basis for use when considering the cost-benefit relationships for new stormwater infrastructure and the flood risk associated with the chosen return period. Nitsch

Engineering uses the Steel Formula to develop IDF curves. The Steel Formula is an empirical equation based in historic rainfall data and is used for defining the Intensity-Duration-Frequency relationships depending on the proposed return periods. For the project, Nitsch Engineering has determined that a 25-year Steel Formula Intensity-Duration-Frequency curve is appropriate for design.

AutoDesk® Storm and Sanitary Analysis Software v. 6.4

Nitsch Engineering used AutoDesk® Storm and Sanitary Analysis Software (“SSA”) to estimate storm system inflows by the Rational Method and to size the proposed closed drainage systems. SSA contains several hydraulic modeling capabilities used to route calculated runoff through drainage system networks

SSA & Free-Flow in Storm Pipes

The closed drainage system has been designed to maintain free-flow conditions. Stormwater in drainage system pipes is considered to be “free-flowing” when the upstream and downstream ends of the pipes are not submerged and the flow within the pipe is below the capacity of the pipe. For these cases, SSA calculates the storm pipe capacity using *Manning’s Equation* which considers pipe slope, material, and interior pipe diameter to estimate capacity. In general, when pipe diameters and slopes increase, capacities increase. Rougher pipe materials will create greater frictional forces which restrict flow when compared to smoother pipe materials. Using Manning’s Equation, SSA also calculates the water surface elevation through pipes and at the pipe beginning and end. This elevation is more commonly known as the “Hydraulic Grade Line” or “HGL”, and helps determine flow conditions and losses through pipe systems.

SSA & Manning’s Equation

SSA software uses *Manning’s Equation* to calculate the full flow capacity of pipes. *Manning’s Equation* is a regularly used formula to calculate the flow within stormwater pipes for free flow conditions. It is commonly written as:

$$Q = 1.49/n A R^{2/3} S^{1/2}$$

where

Q	=	volumetric capacity of flow	n	=	pipe roughness factor
A	=	cross-sectional area of pipe at full flow	R	=	hydraulic radius at full flow
S	=	pipe slope			

It should be noted that the inclusion of the cross-sectional pipe flow area *A* is a common modification to the standard *Manning’s Equation*. The pipe flow area may be removed from the formula to calculate velocity *V* of flow within the pipe. The addition of flow area allows stormwater designers to understand the distance at which a two-dimensional area *A* can move through a pipe over a given time period, typically measured in one second. This enables the calculation of a volumetric flow rate *Q*. For example, if a pipe has a cross-sectional flow area *A* of two square feet and the calculated velocity *V* through the pipe is five feet per second, then the distance that this two square foot area “moves” in one second is five feet. This creates an imaginary cylinder of water that is five feet long. Therefore, the volume of water that flows through the pipe over this one second time period is equal

to two square feet multiplied by five lineal feet, or ten cubic feet. This is important to engineers because it allows the design of stormwater systems to relate to the hydrology calculations which are similarly measured in volumetric flow rates.

A quick assessment of the equation reveals that the pipe geometry and material are significant factors in determining capacity of flow. The pipe roughness factor, n , is an experimentally derived value related to the chosen pipe material. Many elements affect this, including age and condition, material, and shape of the pipe wall (ie, corrugated interiors versus smooth-walled pipes). Generally, as roughness factor increases, the frictional resistance to flow through the pipe increases, thus lowering overall speed of flow and capacity.

When considering this frictional resistance, it is important to note that resistance only occurs along the surfaces of contact between the water flow area and the pipe wall. This contact surface is known as the wetted perimeter. For full flow in circular pipes, this is considered to be the perimeter of the interior pipe wall, and is equal to the diameter of the pipe multiplied by pi.

The wetted perimeter is a significant factor in determining actual flow through a pipe when the pipe is not flowing full, as the surface of the water in the pipe does not contact a pipe wall or contribute to the frictional resistance. The equation accounts for this by applying a ratio of the area of flow to the actual wetted perimeter, otherwise known as the hydraulic radius, or R . In the case of full circular pipe flow, the hydraulic radius is equal to the diameter of the pipe divided by four.

The pipe flow area, or A , defines the two-dimensional space within the pipe that can be used to pass stormwater flow. Logically, the larger the area and pipe diameter, the greater volume of water the pipe can transmit over a given time period.

SSA & Modeling of Hydraulic Losses

Hydraulic Losses through a closed storm drainage network refer to the actions of natural forces which work to restrict flow rates and velocities or otherwise alter the nature of flow in pipe systems. Losses are important to stormwater design because they change the depth of flow in pipes, sometimes significantly, and must be factored into flow systems to obtain accurate hydraulic grade lines and minimize the occurrence of street flooding.

Friction between the moving column of water and pipe wall is more commonly known as *major losses*. Flow through storm pipes is generally accomplished by the pull of gravity on the water in the pipe acting to accelerate it from the higher end of the pipe to the lower end. The force of friction between the water and the pipe acts to resist the pull of gravity, and this resistance increases with the velocity of flow. As such, the pull of gravity can either be greater than the pull of friction (*subcritical flow*) or the pull of friction can be greater than the pull of gravity (*supercritical flow*). Subcritical flow tends to be deeper and slower, and supercritical flow tends to be shallower and faster. SSA uses *Manning's Equation* to determine the relationships between flow depth and velocity in free-flow conditions. In addition, SSA is able to determine the point at which friction forces overcome gravitational forces causing a *hydraulic jump*, or a point in the flow regime where depth quickly increases and flow quickly decreases due to a rapid change in velocity.

Other types of losses include changes in the flow direction or flow cross-section, such as bends, expansions from smaller to larger pipes, or entrances to or exits from storm drainage structures like

manholes. These are more commonly known as *minor losses*. For the calculation of minor losses, SSA uses scientifically derived formulas which are typical of the industry.

Losses are measured in units of length, typically in lineal feet for closed system design. This is easily understood when considering that the speed of water at the outfall of a pipe is directly calculated from the change in vertical distance over which gravity acts. Typically, the larger this change in height, the steeper the slope of the pipe, and the faster the column of water will travel through the pipe. SSA uses this information and applies it to the height of vertical columns of water in closed drainage systems to determine actual HGLs relative to the rim grades of structures.

AutoDesk® Storm and Sanitary Analysis: Understanding this Report

Nitsch Engineering used AutoDesk® Storm and Sanitary Analysis Software (“SSA”) to estimate storm system inflows by the Rational Method and to size the proposed closed drainage systems. SSA contains several hydraulic modeling capabilities which are used to simultaneously route calculated runoff through complicated drainage system networks. The software can support both free-flow and surcharged pipe conditions. The results of these analyses are automatically compiled into tabular reports by the program as described below. This document is intended to help explain the definition of terms and the interpretation in stormwater design.

The following includes definitions of the different reports, data, and terms as generated by the SSA model for this project.

“Project Description” Section:

File Name: The name of the stormwater model computer file

“Rainfall Details” Section:

Return Period: The selected return period of the IDF curve chosen for the hydrologic model

“Subbasin Summary” Section:

This section contains a summary of the inputs and calculations of all subbasins, or drainage areas, within the hydrology model.

SN: The assigned subbasin number

Subbasin ID: The name assigned to the subbasin

Area: The area of the drainage subbasin used to calculate the Peak Runoff Rate

Weighted Runoff Coefficient: The dimensionless Rational C value for the drainage subbasin reflecting the subbasin’s surface cover and ability to absorb rainfall

Peak Runoff: The calculated volumetric flow rate using the Rational Method

Time of Concentration: The length of time between the start of the analysis and the time when the Peak Flow Rate Q is achieved

“Link Summary” Section:

This section contains a summary of the calculations for the closed drainage pipe network.

From (Inlet) Node: The upstream structure, or node, of the pipe

Inlet Invert Elevation: The elevation of the upstream invert of the pipe used to calculate Pipe Slope

To (Outlet) Node: The downstream structure, or node, of the pipe

<u>Outlet Invert Elevation:</u>	The elevation of the downstream invert of the pipe used to calculate Pipe Slope
<u>Length:</u>	The length of the pipe used to calculate the Pipe Slope
<u>Pipe Slope:</u>	The slope of the pipe calculated by subtracting the Outlet Invert Elevation from the Inlet Invert Elevation and dividing by pipe Length
<u>Pipe Diameter:</u>	The interior diameter of the pipe used to calculate the Pipe Design Capacity, Peak Flow Velocity, and Peak Flow Depth
<u>Manning's Roughness:</u>	A dimensionless coefficient describing the relative roughness of the interior pipe surface as determined from the pipe material. This coefficient is used to calculate the Pipe Flow Velocity and Pipe Design Capacity
<u>Peak Flow Q:</u>	The peak volumetric flow rate through the pipe. This is calculated from the contributing subbasin hydrology. This is used to calculate Peak Flow Velocity, Q/Qf Ratio, and Peak Flow Depth
<u>Peak Flow Velocity:</u>	The average speed of the runoff moving through the pipe during Peak Flow
<u>Pipe Design Capacity Qf:</u>	The maximum capacity of the pipe as calculated using <i>Manning's Equation</i>
<u>Q/Qf Ratio:</u>	The ratio of the Peak Flow Q to Pipe Design Capacity Qf. Values of less than 1.00 indicate that the Peak Flow Rate Q does not exceed the capacity of the pipe. Values of greater than 1.00 indicate that the pipe is under capacity and flows under submerged conditions.
<u>Peak Flow Depth:</u>	The depth of the flow, in feet, as measured from the invert of the pipe at the point of maximum depth. For free flow conditions, this value is assumed to be uniform throughout the pipe.

“Subbasin Hydrology” Sections:

These sections contain the full calculations and results for the individual subbasins, or drainage areas, including the Weighted Rational Coefficients, Times of Concentration, and Rational Method Runoff calculations that are included as a part of the hydrologic model and subbasin summary report.

Rainfall Details

Return Period..... 25 year(s)

Subbasin Summary

Subbasin Name	Area (ac)	Weighted Runoff Coefficient	Peak Runoff (cfs)	Time of Concentration (days hh:mm:ss)
Sub-01	0.10	0.60	0.38	0 00:06:00
Sub-02	0.07	0.73	0.33	0 00:06:00
Sub-03	0.05	0.78	0.25	0 00:06:00
Sub-04	0.03	0.90	0.17	0 00:06:00
Sub-05	0.06	0.90	0.35	0 00:06:00
Sub-06	0.10	0.72	0.46	0 00:06:00
Sub-07	0.11	0.90	0.63	0 00:06:00
Sub-08	0.19	0.74	0.90	0 00:06:00
Sub-09	0.11	0.90	0.63	0 00:06:00
Sub-10	0.12	0.90	0.69	0 00:06:00
Sub-11	0.07	0.64	0.29	0 00:06:00
Sub-12	0.09	0.77	0.44	0 00:06:00
Sub-13	0.08	0.75	0.38	0 00:06:00
Sub-14	0.11	0.74	0.52	0 00:06:00
Sub-15	0.10	0.84	0.54	0 00:06:00
Sub-16	0.11	0.79	0.56	0 00:06:00
Sub-17	0.24	0.70	1.07	0 00:06:00
Sub-18	0.10	0.90	0.58	0 00:06:00
Sub-19	0.30	0.90	1.73	0 00:06:00
Sub-20	0.03	0.70	0.13	0 00:06:00
Sub-21	0.16	0.79	0.81	0 00:06:00
Sub-22	0.07	0.47	0.21	0 00:06:00
Sub-23	0.12	0.75	0.58	0 00:06:00
Sub-24	0.29	0.36	0.67	0 00:06:00
Sub-25	0.01	0.90	0.06	0 00:06:00

Link Summary

Pipe Name	From (Inlet) Node	Inlet To Invert (Outlet) Elevation Node	Outlet Invert Elevation	Pipe Length	Pipe Slope	Pipe Diameter	Manning's Roughness	Peak Flow	Peak Flow Velocity	Pipe Design Capacity	Q/Qf Ratio
		(ft)	(ft)	(ft)	(%)	(in)		(cfs)	(ft/sec)	(cfs)	
Pipe - (108)	WQS501	11.35 Out-1Pipe - (108)	11.30	12	0.41	15	0.0120	4.11	3.65	4.47	0.92
Pipe - (115) (1) (1) (1)	DMH131	11.40 WQS501	11.35	9	0.54	15	0.0120	4.11	3.36	5.12	0.80
Pipe - (124)	AD306	17.41 WYE#1	17.25	8	1.94	8	0.0120	0.51	2.96	1.82	0.28
Pipe - (125)	AD308	17.34 DMH132	17.25	10	0.92	8	0.0120	0.53	2.95	1.26	0.42
Pipe - (127)	DMH132	16.90 DMH126	14.00	163	1.78	12	0.0120	1.41	5.10	5.15	0.27
Pipe - (128)	DMH126	13.05 DMH142	12.85	42	0.47	15	0.0120	4.45	3.63	4.82	0.92
Pipe - (129)	DMH142	12.75 DMH144	12.45	67	0.45	15	0.0120	4.45	3.63	4.70	0.95
Pipe - (129) (1)	DMH144	12.35 DMH133	12.25	19	0.52	18	0.0120	6.00	3.40	8.21	0.73
Pipe - (130)	TD#2	12.60 DMH138	12.40	22	0.90	6	0.0120	0.67	3.40	0.58	1.15
Pipe - (131)	DMH138	12.30 DMH133	12.20	11	0.89	12	0.0120	0.68	2.13	3.63	0.19
Pipe - (133)	AD304	17.48 DMH134	17.40	20	0.40	8	0.0120	0.37	2.24	0.83	0.45
Pipe - (136)	DMH134	17.30 WYE#1	17.25	14	0.37	12	0.0120	0.37	1.31	2.34	0.16
Pipe - (136) (1)	WYE#1	17.25 DMH132	17.00	30	0.82	12	0.0120	0.87	3.31	3.50	0.25
Pipe - (139)	DMH133	12.15 WQS500	12.05	18	0.56	18	0.0120	6.57	3.75	8.55	0.77
Pipe - (139) (1)	WQS500	12.05 Out-1Pipe - (139) (1)	12.00	11	0.46	18	0.0120	6.57	4.20	7.75	0.85
Pipe - (162)	TD#3	15.30 DMH138	14.90	14	2.82	6	0.0120	0.06	2.63	1.02	0.05
Pipe - (182)	AD300	15.70 DMH144	15.10	43	1.40	8	0.0120	0.13	2.60	1.55	0.08
Pipe - (225)	DMH136	12.80 DMH119	12.50	35	0.86	12	0.0120	0.16	1.77	3.58	0.04
Pipe - (234)	CB209	12.75 DMH120	12.25	73	0.69	12	0.0120	0.34	1.60	3.20	0.11
Pipe - (235) (1)	DMH120	12.25 DMH119	12.18	19	0.37	12	0.0120	0.47	1.55	2.33	0.20
Pipe - (243)	CB210	13.25 DMH137	13.10	22	0.67	12	0.0120	0.57	1.84	3.17	0.18
Pipe - (244)	CB207	13.25 DMH137	13.10	23	0.65	12	0.0120	0.84	2.22	3.10	0.27
Pipe - (245)	DMH137	13.00 DMH121	12.80	44	0.45	12	0.0120	1.25	2.24	2.60	0.48
Pipe - (263)	DMH121	12.80 WYE#6	12.68	20	0.57	12	0.0120	1.42	2.24	2.90	0.49
Pipe - (263) (1)	WYE#6	12.68 WYE#5	12.56	22	0.57	12	0.0120	1.39	2.25	2.90	0.48
Pipe - (263) (1) (1)	WYE#5	12.56 DMH127	12.40	28	0.57	12	0.0120	1.48	2.16	2.90	0.51
Pipe - (266)	AD303	14.43 DMH147	14.30	9	1.52	8	0.0120	0.20	2.64	1.61	0.13
Pipe - (267)	AD302	14.47 DMH147	14.40	33	0.21	8	0.0120	0.56	2.35	0.60	0.92
Pipe - (268)	DMH147	13.90 DMH144	13.50	92	0.43	12	0.0120	1.49	3.25	2.54	0.59
Pipe - (273)	AD301	14.19 DMH140	14.05	21	0.66	8	0.0120	0.59	2.10	1.07	0.55
Pipe - (274)	AD305	14.04 DMH140	13.93	22	0.49	8	0.0120	1.72	4.94	0.92	1.87
Pipe - (275)	DMH140	13.90 DMH117	13.35	89	0.62	12	0.0120	2.30	2.93	3.04	0.76
Pipe - (278)	DMH117	13.25 DMH126	13.15	23	0.44	12	0.0120	3.54	4.50	2.56	1.38
Pipe - (279)	TD#1	15.75 DMH117	15.70	4	1.15	12	0.0120	0.55	2.94	4.14	0.13
Pipe - (280)	AD307	14.50 DMH118	14.30	18	1.09	8	0.0120	0.79	3.34	1.37	0.58
Pipe - (281)	CB221	13.00 DMH127	12.28	40	1.82	12	0.0120	0.26	0.85	5.12	0.05
Pipe - (283)	CB218	13.00 DMH121	12.80	35	0.56	12	0.0120	0.37	1.86	2.90	0.13
Pipe - (284)	CB205	12.74 DMH120	12.68	13	0.47	12	0.0120	0.30	1.95	2.65	0.11
Pipe - (286)	DMH119	12.18 DMH115	11.95	44	0.52	12	0.0120	0.82	1.84	2.79	0.29
Pipe - (287)	CB208	13.00 DMH115	12.90	9	1.07	12	0.0120	0.17	2.22	3.99	0.04
Pipe - (289)	CB213	12.77 DMH119	12.60	39	0.44	12	0.0120	0.23	1.81	2.55	0.09
Pipe - (293)	DMH115	11.95 DMH139	11.80	26	0.57	12	0.0120	0.95	1.21	2.92	0.32
Pipe - (295)	DMH139	11.80 WYE#2	11.71	11	0.85	15	0.0120	3.39	2.76	6.45	0.53
Pipe - (295) (1)	WYE#2	11.71 DMH116	11.53	21	0.85	15	0.0120	3.47	2.83	6.45	0.54
Pipe - (296)	DMH116	11.43 DMH131	11.40	6	0.49	15	0.0120	3.56	2.90	4.89	0.73
Pipe - (300)	DMH127	12.30 WYE#4	12.21	14	0.62	12	0.0120	2.12	2.69	3.03	0.70
Pipe - (300) (1)	WYE#4	12.21 WYE#3	12.08	22	0.62	12	0.0120	2.20	2.80	3.03	0.73
Pipe - (300) (1) (1)	WYE#3	12.08 DMH139	11.90	29	0.62	12	0.0120	2.28	2.90	3.03	0.75
Pipe - (304)	CB204	13.78 DMH139	13.00	38	2.06	12	0.0120	0.68	4.40	5.54	0.12
Pipe - (305)	CB219	13.78 DMH127	12.75	39	2.66	12	0.0120	0.63	3.99	6.29	0.10
Pipe - (306)	CB217	13.25 DMH135	13.00	4	6.09	12	0.0120	0.44	4.49	9.52	0.05
Pipe - (307)	DMH135	11.43 DMH131	11.40	5	0.59	12	0.0120	0.80	1.91	2.96	0.27
Pipe - (309)	CB214	13.00 DMH135	12.80	37	0.53	12	0.0120	0.28	2.15	2.82	0.10
Pipe - (311)	TD#4	15.71 DMH117	15.68	3	1.00	12	0.0120	1.07	3.34	3.86	0.28
Pipe - (312)	DMH118	14.20 DMH147	14.00	22	0.89	8	0.0120	0.78	2.75	1.24	0.63

Junction Input

Junction Name	Invert Elevation	Rim Elevation
	(ft)	(ft)
AD300	15.70	18.01
AD301	14.19	16.48
AD302	14.47	16.83
AD303	14.43	16.74
AD304	17.48	19.78
AD305	14.04	16.48
AD306	17.41	19.71
AD307	14.50	16.88
AD308	17.34	19.64
CB204	13.78	16.29
CB205	12.74	16.24
CB207	13.25	16.75
CB208	13.00	16.50
CB209	12.75	16.25
CB210	13.25	16.75
CB213	12.77	16.28
CB214	13.00	16.50
CB217	13.25	16.75
CB218	13.00	16.51
CB219	13.78	17.39
CB221	13.00	16.50
DMH115	11.95	16.75
DMH116	11.43	16.69
DMH117	13.25	19.79
DMH118	14.20	18.10
DMH119	12.18	16.74
DMH120	12.25	16.70
DMH121	12.80	16.76
DMH126	13.05	20.03
DMH127	12.30	16.70
DMH131	11.40	16.75
DMH132	16.90	19.75
DMH133	12.10	21.58
DMH134	17.30	19.96
DMH135	11.43	16.75
DMH136	12.80	16.75
DMH137	13.00	16.75
DMH138	12.30	17.65
DMH139	11.80	16.71
DMH140	13.90	16.92
DMH142	12.75	20.46
DMH144	12.30	21.38
DMH147	13.90	17.44
TD#1	15.75	-2.94
TD#2	12.60	17.55
TD#3	15.30	21.75
TD#4	15.71	16.87
WQS500	12.05	20.85
WQS501	11.35	16.72
WYE#1	17.25	21.05
WYE#2	11.71	14.50
WYE#3	12.08	14.49
WYE#4	12.21	14.58
WYE#5	12.56	14.46
WYE#6	12.68	14.46

APPENDIX E

Long-Term Pollution Prevention and Stormwater Operation and Maintenance Plan

LONG-TERM POLLUTION PREVENTION PLAN AND STORMWATER OPERATION AND MAINTENANCE PLAN

2 Harbor Street, Boston, MA

TABLE OF CONTENTS

1.0 INTRODUCTION	1
2.0 LONG-TERM POLLUTION PREVENTION PLAN	2
2.1 Storage of Hazardous Materials	2
2.2 Storage of Waste Products	2
2.3 Spill Prevention and Response	2
2.4 Minimize Soil Erosion	2
2.5 Vehicle Washing	3
2.6 Maintenance of Lawns, Gardens, and other Landscaped Areas	3
2.7 Management of Deicing Chemicals and Snow	3
2.8 Coordination with other Permits and Requirements	3
3.0 STORMWATER MANAGEMENT SYSTEM OPERATION AND MAINTENANCE PLAN 5	
3.1 Introduction	5
3.2 Stormwater Operation and Maintenance Requirements	5
Deep Sump and Hooded Catch Basins	5
Porous Pavers	6
Area Drains	6
Water Quality Units (Proprietary Separators)	6
Subsurface Detention/Infiltration Structures	7
3.3 Street Sweeping	7
3.4 Repair of the Stormwater Management System	7
3.5 Reporting	7
STORMWATER MANAGEMENT SYSTEM INSPECTION FORM	8

1.0 INTRODUCTION

The purpose of this document is to specify the pollution prevention measures and stormwater management system operation and maintenance for the 2 Harbor Street site. The Responsible Party indicated below shall implement the management practices outlined in this document and proactively conduct operations at the project site in an environmentally responsible manner. Compliance with this Manual does not in any way dismiss the responsible party, owner, property manager, or occupants from compliance with other applicable federal, state or local laws.

Responsible Party: Eric Ewer
200 State Street, Boston, MA 02109
617-293-8311

This Document has been prepared in compliance with Standards 4 and 9 of the 2008 Massachusetts Department of Environmental Protection (MassDEP) Stormwater Management Standards, which state:

Standard 4:

The Long Term Pollution Prevention Plan shall include the proper procedures for the following:

- Good housekeeping
- Storing materials and waste products inside or under cover
- Vehicle washing
- Routine inspections of stormwater best management practices
- Spill prevention and response
- Maintenance of lawns, gardens, and other landscaped areas
- Storage and use of fertilizers, herbicides, and pesticides
- Pet waste management
- Operation and management of septic systems
- Proper management of deicing chemicals and snow

Standard 9:

The Long-Term Operation and Maintenance Plan shall at a minimum include:

- Stormwater management system(s) owner(s)
- The party or parties responsible for operation and maintenance, including how future property owners shall be notified of the presence of the stormwater management system and the requirement for operation and maintenance
- The routine and non-routine maintenance tasks to be undertaken after construction is complete and a schedule for implementing those tasks
- A plan that is drawn to scale and shows the location of all stormwater BMPs in each treatment train along with the discharge point
- A description and delineation of public safety features
- An estimated operations and maintenance budget

2.0 LONG-TERM POLLUTION PREVENTION PLAN

The Responsible Party shall implement the following good housekeeping procedures at the project site to reduce the possibility of accidental releases and to reduce safety hazards.

2.1 Storage of Hazardous Materials

To prevent leaks and spills, keep hazardous materials and waste products under cover or inside. Use drip pans or spill containment systems to prevent chemicals from entering the drainage system. Inspect storage areas for materials and waste products at least once per year to determine amount and type of the material on site, and if the material requires disposal.

Securely store liquid petroleum products and other liquid chemicals in federally- and state-approved containers. Restrict access to maintenance personnel and administrators.

2.2 Storage of Waste Products

Collect and store all waste materials in securely lidded dumpster(s) or other secure containers as applicable to the material. Keep dumpster lids closed and the areas around them clean. Do not fill the dumpsters with liquid waste or hose them out. Sweep areas around the dumpster regularly and put the debris in the garbage, instead of sweeping or hosing it into the parking lot. Legally dispose of collected waste on a regular basis.

Segregate liquid wastes, including motor oil, antifreeze, solvents, and lubricants, from solid waste and recycle through hazardous waste disposal companies, whenever possible. Separate oil filters, batteries, tires, and metal filings from grinding and polishing metal parts from common trash items and recycle. These items are not trash and are illegal to dump. Contact a hazardous waste hauler for proper disposal to a hazardous waste collection center.

2.3 Spill Prevention and Response

Implement spill response procedures for releases of significant materials such as fuels, oils, or chemical materials onto the ground or other area that could reasonably be expected to discharge to surface or groundwater.

- For minor spills, keep fifty (50) gallon spill control kits and Speedy Dry at all shop and work areas.
- Immediately contact applicable Federal, State, and local agencies for reportable quantities as required by law.
- Immediately perform applicable containment and cleanup procedures following a spill release.
- Promptly remove and dispose of all material collected during the response in accordance with Federal, State and local requirements. A licensed emergency response contractor may be required to assist in cleanup of releases depending on the amount of the release, and the ability of the Contractor to perform the required response.
- Reportable quantities of chemicals, fuels, or oils are established under the Clean Water Act and enforced through Massachusetts Department of Environmental Protection (DEP).

2.4 Minimize Soil Erosion

Soil erosion facilitates mechanical transport of nutrients, pathogens, and organic matter to surface water bodies. Repair all areas where erosion is occurring throughout the project site. Stabilize bare soil with riprap, seed, mulch, or vegetation.

2.5 Vehicle Washing

Vehicle washing will not occur onsite.

2.6 Maintenance of Lawns, Gardens, and other Landscaped Areas

Pesticides and fertilizers shall not be used in the landscaped areas associated with the project site and shall not be stored on-site. Dumping of lawn wastes, brush or leaves or other materials or debris is not permitted onsite. Grass clippings, pruned branches and any other landscaped waste should be disposed of or composted in an appropriate offsite location. No irrigation shall be used in the landscaped areas for this project.

2.7 Management of Deicing Chemicals and Snow

The qualified contractor selected for snow plowing and deicing shall be made fully aware of the requirements of this section.

No road salt (sodium chloride) shall be stored on-site. The use of magnesium chloride de-icing product with a 0.5 to 1.0 percent sodium chloride mix for snow and ice treatment is permitted. The product shall be stored in a locked room inside the building and shall be used at exterior stairs and walkways. The snow plow contractor shall adhere to these magnesium chloride use and storage requirements.

During typical snow plowing operations, snow shall be pushed to the designated snow removal areas noted on the Snow Storage Plan (Figure 2). Snow shall not be stockpiled in wetland resource areas or catch basins. In severe conditions where snow cannot be stockpiled on site, the snow shall be removed from the site and properly disposed of in accordance with DEP Guideline BRP601-01.

Use of sand is permitted only for impervious roadways and parking areas. If sand is applied, the snow plowed from impervious areas shall not be stored on porous pavers.

Porous paver areas are proposed throughout the site, as indicated on the Stormwater Management System Location Map (Figure 1). Porous pavers performs well in cold climates and can reduce meltwater runoff during the snowmelt period; however there are specific winter management techniques that must be followed for porous asphalt systems.

The porous paver areas shall be maintained during snow events as provided below:

- Apply anti-icing treatments only when absolutely necessary (in extreme events). It is not anticipated that deicing chemicals will be required for typical winter events.
- Plow as needed after storm events. Avoid scarifying the porous paver surface. Special plow blades should be used whenever possible. Raised blade is not recommended.
- Apply the minimum amount of deicing agents during and after storms required to control compact snow and ice that are not removed by plowing.
- Do not apply sand in porous paver areas "No Sanding" signs shall be posted before the first snowfall and maintenance and snow removal contractors shall be made aware of this requirement.

Before winter begins, the property owner and the contractor shall review snow plowing, deicing, and stockpiling procedures. Areas designated for stockpiling should be cleaned of any debris. Street and parking lot sweeping should be followed in accordance with the Operation and Maintenance Plan.

2.8 Coordination with other Permits and Requirements

Certain conditions of other approvals affecting the long term management of the property shall be

2 Harbor Street, Boston, MA
Long Term Pollution Prevention Plan & Stormwater
Operation and Maintenance Plan

Notice of Intent
April 16, 2021

considered part of this Long Term Pollution Prevention Plan. The Owner shall become familiar with those documents and comply with the guidelines set forth in those documents.

3.0 STORMWATER MANAGEMENT SYSTEM OPERATION AND MAINTENANCE PLAN

3.1 Introduction

This Operation and Maintenance Plan (O&M Plan) for 2 Harbor Street site is required under Standard 9 of the 2008 MassDEP Stormwater Handbook to provide best management practices for implementing maintenance activities for the stormwater management system in a manner that minimizes impacts to wetland resource areas.

The Owner shall implement this O&M Plan and proactively conduct operations at the site in an environmentally responsible manner. Compliance with this O&M Plan does not in any way dismiss the Owner from compliance with other applicable Federal, State or local laws.

Routine maintenance during construction and post-development phases of the project, as defined in the Operation and Maintenance Plan, shall be permitted without amendment to the Order of Conditions. A continuing condition in the Certificate of Compliance shall ensure that maintenance can be performed without triggering further filings under the Wetlands Protection Act.

All stormwater best management practices (BMPs) shall be operated and maintained in accordance with the design plans and the Operation and Maintenance Plan approved by the issuing authority. The Owner shall:

- a. Maintain an operation and maintenance log for the last three years, including inspections, repairs, replacement and disposal (for disposal the log shall indicate the type of material and the disposal location). This is a rolling log in which the responsible party records all operation and maintenance activities for the past three years.
- b. Make this log available to MassDEP and the Conservation Commission upon request; and
- c. Allow members and agents of the MassDEP and the Conservation Commission to enter and inspect the premises to evaluate and ensure that the Owner complies with the Operation and Maintenance requirements for each BMP.

3.2 Stormwater Operation and Maintenance Requirements

Inspect and maintain the stormwater management system as directed below. Refer to the Stormwater Management System Location Map (Figure 1) for the location of each component of the system. Repairs to any component of the system shall be made as soon as possible to prevent any potential pollutants (including silt) from entering the resource areas.

Deep Sump and Hooded Catch Basins

Inspect or clean catch basins four times per year and at the end of foliage and snow-removal seasons. Other inspection and maintenance requirements include:

- Remove organic material, sediment and hydrocarbons four times per year or whenever the depth of deposits is greater than or equal to one half the depth from the bottom of the invert of the lowest pipe in the basin.
- Always clean out catch basins after street sweeping. If any evidence of hydrocarbons is found during inspection, immediately remove the material using absorbent pads or other suitable measures and dispose of legally. Remove other accumulated debris as necessary.
- If handling runoff from land uses with higher potential pollutant loads or discharging runoff near or to a critical area, more frequent cleaning may be necessary.

- Transport and disposal of accumulated sediment off-site shall be in accordance with applicable local, state and federal guidelines and regulations.

Porous Pavers

Porous paver areas are proposed throughout the site, as indicated on the Stormwater Management System Location Map (Figure 1).

Frequent cleaning and maintenance of the porous pavement surface is critical to prevent clogging. Frequent vacuum sweeping along with jet washing of porous pavement is required. No winter sanding shall be conducted on the porous surface. For proper maintenance:

- Minimize salt use during winter months.
- No winter sanding is allowed.
- Keep landscaped areas well maintained to prevent soil from being transported onto the pavement.
- Regularly monitor the porous paver surface to make sure that it drains properly after storm events. Inspect surface annually for deterioration or spalling.
- At a minimum, the porous pavers shall be cleaned after the winter season and every three months thereafter. This requirement may be adjusted as needed, based on regular visual inspections of the porous pavement surface.
- For paving stones, add joint material to replace material that has been transported. Reseed grass pavers to fill in bare spots.
- Never reseal or repave with impermeable materials.
- Attach rollers to the bottoms of snowplows to prevent them from catching on the edges of grass pavers and some paving stones.

Area Drains

Inspect area drains at least once per month and remove debris from the grate. Clean out accumulated sediments at least once per year and more frequently as necessary.

Water Quality Units (Proprietary Separators)

Maintain water quality units according the recommendations set forth by the manufacturer. General inspection and maintenance procedures for proprietary devices are provided below:

- Inspect units following completion of construction, prior to being put into service.
- Inspect units at least twice per year following installation and no less than once per year thereafter.
- Inspect units immediately after any oil, fuel or chemical spill.
- All inspections shall include checking the oil level and sediment depth in the unit. Removal of sediments/oils shall occur per manufacturer recommendations.
- A licensed waste management company shall remove captured petroleum waste products from any oil, chemical or fuel spills and dispose.
- OSHA confined space entry protocols shall be followed if entry into the unit is required.

Subsurface Detention/Infiltration Structures

- Inspect subsurface detention/infiltration structures twice per year. Inspect the inlets and observation ports to determine if there is accumulated sediment within the system. Remove all debris and accumulated sediment that may clog the system.

3.3 Street Sweeping

Perform street sweeping at least twice per year, whenever there is significant debris present on roads and parking lots. Street sweeping shall occur in the spring and fall. Sweepings must be handled and disposed of properly according to the Boston Conservation Commissions.

3.4 Repair of the Stormwater Management System

The stormwater management system shall be maintained. The repair of any component of the system shall be made as soon as possible to prevent any potential pollutants including silt from entering the resource areas or the existing closed drainage system.

3.5 Reporting

The Owner shall maintain a record of drainage system inspections and maintenance (per this Plan) and submit a yearly report to the Boston Conservation Commissions.

STORMWATER MANAGEMENT SYSTEM INSPECTION FORM

2 Harbor Street Boston, MA		Inspected by: _____ Date: _____
Component	Status/Inspection	Action Taken
Deep Sump Catch Basins, Area Drains and Drain Manholes		
Subsurface Infiltration System		
Water Quality Units		
Porous Pavers		
General site conditions – evidence of erosion, etc.		

**SUBMIT COPIES OF STORMWATER MANAGEMENT SYSTEM INSPECTION FORM TO THE
BOSTON CONSERVATION COMMISSIONS WITH THE YEARLY REPORT.**

APPENDIX F

DRAFT Stormwater Pollution Prevention Plan (SWPPP)

Stormwater Pollution Prevention Plan (SWPPP)

For Construction Activities At:

2 Harbor

2 Harbor Street

Boston, MA 02110

Site Telephone Number: xxx-xxx-xxxx

SWPPP Prepared For:

Beacon Capital Partners

Eric Ewer

200 State Street

Boston, MA 02109

T: 617-457-0400

eewer@beaconcapital.com

SWPPP Prepared By:

Nitsch Engineering

Chris Hodney, PE

Gavin Graham

2 Center Plaza

Boston, MA 02108

T: 617-338-0063

F: 617-338-6472

SWPPP Preparation Date:

04/09/2021

Estimated Project Dates:

Project Start Date: xx/xx/xxxx

Project Completion Date: xx/xx/xxxx



Table of Contents

SECTION 1: CONTACT INFORMATION/RESPONSIBLE PARTIES 0

1.1 Operator(s) / Subcontractor(s)..... 0

1.2 Stormwater Team..... 2

SECTION 2: SITE EVALUATION, ASSESSMENT, AND PLANNING..... 3

2.1 Project/Site Information..... 3

2.2 Discharge Information..... 4

2.3 Nature of the Construction Activity..... 6

2.4 Sequence and Estimated Dates of Construction Activities 7

2.5 Allowable Non-Stormwater Discharges 8

2.6 Site Maps..... 9

SECTION 3: DOCUMENTATION OF COMPLIANCE WITH OTHER FEDERAL REQUIREMENTS10

3.1 Endangered Species Protection10

3.2 Historic Preservation.....11

3.3 Safe Drinking Water Act Underground Injection Control Requirements12

SECTION 4: EROSION AND SEDIMENT CONTROLS REQUIREMENTS13

4.1 Natural Buffers or Equivalent Sediment Controls13

4.3 Sediment Track-Out.....14

4.4 Stockpiled Sediment or Soil.....14

4.6 Minimize the Disturbance of Steep Slopes16

4.7 Preserve Native Topsoil16

4.8 Minimize Soil Compaction.....16

4.9 Storm Drain Inlets17

4.10 Minimize Erosion of Stormwater Conveyances17

4.12 Chemical Treatment.....17

4.13 Dewatering Practices.....18

4.14 Other Stormwater Controls.....18

4.15 Site Stabilization.....18

SECTION 5: POLLUTION PREVENTION STANDARDS19

5.1 Potential Sources of Pollution19

5.2 Spill Prevention and Response.....21

5.3 Fueling and Maintenance of Equipment or Vehicles.....21

5.4 Washing of Equipment and Vehicles.....22

**5.5 Storage, Handling, and Disposal of Construction Products, Materials, and Wastes
22**

**5.6 Washing of Applicators and Containers used for Paint, Concrete, or Other Materials
25**

5.8 Other Pollution Prevention Practices.....26

SECTION 6: INSPECTION AND CORRECTIVE ACTION.....27

6.1 Inspection Personnel and Procedures.....27

6.2 Corrective Action.....28

6.3 Delegation of Authority.....28

SECTION 7: TRAINING LOG.....29

SECTION 8: CERTIFICATION AND NOTIFICATION.....30

SWPPP ATTACHMENTS.....31

SECTION 1: CONTACT INFORMATION/RESPONSIBLE PARTIES

1.1 Operator(s) / Subcontractor(s)

Operator(s):

Construction Manager Responsibilities:

Construction Manager shall maintain the Stormwater Pollution Prevention Plan (SWPPP) documentation and will conduct and document self-inspections required under the 2017 Construction General Permit (CGP) once every 14 days and within 24 hours of a storm event 0.25" or greater.

Construction Manager will provide copies of inspections reports to the Owner's Representative within 24 hours following each inspection. Incidents of non-compliance will be immediately brought to the attention of the Owner's Representative. **Construction Manager** shall be responsible for maintaining compliance with the SWPPP, including all requirements in the CGP and will maintain erosion and sediment control Best Management Practices (BMPs) in all areas of the site under its day-to-day control.

Construction Manager shall file a Notice of Intent (NOI) to be covered by the CGP and obtain coverage by the Environmental Protection Agency (EPA) before beginning construction at the project. Permit coverage will be maintained throughout the project. **Construction Manager** shall not file a Notice of Termination (NOT) until all disturbed areas of the site under its day-to-day control have been fully stabilized with permanent erosion controls that satisfy the final stabilization requirements in the CGP or have met another criteria of the NOT. **Construction Manager** will maintain a clean site and construction trash and debris will be picked up and disposed of properly by the end of each day.

Each Operator is responsible for advising employees and subcontractors working on this project of the requirements in the CGP and SWPPP. Particular emphasis should be placed on ensuring that employees and subcontractors do not damage BMPs and maintain compliance with the CGP.

Construction Manager Company Name

Construction Manager Contact Person, Position

Street Address

Town, State, Zip Code

T: xxx-xxx-xxxx

Email address:

Owner's Representative Responsibilities:

Owner's Representative shall provide general oversight of the project including review of the SWPPP and any amendments, inspection reports, and corrective actions. **Owner's Representative** shall file a NOI to be covered by the CGP and obtain coverage by the EPA before beginning construction at the project. Permit coverage will be maintained throughout the project. **Owner's Representative** shall not file a notice of Termination until all disturbed areas of the site have been fully stabilized with permanent erosion controls that satisfy the final stabilization requirements in the CGP. **Owner's Representative** will coordinate with the **Construction Manager** to maintain a clean site so that trash and debris will be picked up and disposed of properly by the end of the day.

Each Operator is responsible for advising employees and subcontractors working on this project of the requirements in the CGP and SWPPP. Particular emphasis should be placed on ensuring that employees and subcontractors do not damage BMPs and maintain compliance with the CGP.

Owner's Representative Company Name

Owner's Representative Contact person, Position

Street Address

Town, State, Zip Code

T: xxx-xxx-xxxx

Email Address:

Site Contractor:

Company Name

Contact person, Position

Street Address

Town, State, Zip Code

T: xxx-xxx-xxxx

Email Address:

Emergency 24-Hour Contact:

Company

Emergency Contact person, Position

T: xxx-xxx-xxxx

1.2 Stormwater Team

Construction Manager: Company

Stormwater Role/Responsibility: Responsible for overseeing the development of the SWPPP, modifications and updates to the SWPPP, and for compliance with the requirements in the CGP (e.g., installing and maintaining stormwater controls, conducting site inspections, picking up trash, taking corrective actions where required, etc.).

Contact:

Construction Manager Contact Person, Position

T: xxx-xxx-xxxx

Email address

I, **Construction Manager Contact Person**, have read the CGP and Understand the Applicable Requirements

Yes

Date: _____

Site Contractor: Company

Stormwater Role/Responsibility: Responsible for compliance with the requirements in this permit (e.g., installing and maintaining stormwater controls, conducting site inspections, taking corrective actions where required, etc.).

Contact:

Contact Person, Position

T: xxx-xxx-xxxx

Email Address

Refer to the Subcontractor Certifications/Agreements in Attachment G.

SECTION 2: SITE EVALUATION, ASSESSMENT, AND PLANNING

2.1 Project/Site Information

Project Name and Address

Project/Site Name: 2 Harbor Street
Project Street/Location: 2 Harbor Street
City/Town: Boston
State: Massachusetts
ZIP Code: 02110
County or Similar Subdivision: Suffolk

Project Latitude/Longitude

(Use **one** of three possible formats, and specify method)

Latitude: 1. 42.346555° (degrees, decimals) Longitude: 1. -71.036064 (degrees, decimals)

Method for determining latitude/longitude:
 USGS topographic map (specify scale: _____) GPS
 Other (please specify): Google Maps

Horizontal Reference Datum:
 NAD 27 NAD 83 WGS 84

If you used a U.S.G.S topographic map, what was the scale? _____

Additional Project Information

Is the project/site located on Indian country lands, or located on a property of religious or cultural significance to an Indian tribe? Yes No

Are you applying for permit coverage as a “federal operator” as defined in Appendix A of the CGP?
 Yes No

Will there be demolition of any structure built or renovated before January 1, 1980?
 Yes No

If yes, do any of the structures being demolished have at least 10,000 square feet of floor space?
 Yes No

Was pre-development land use used for agriculture (see Appendix A of the CGP for definition of “agricultural land”)?
 Yes No

Type of Construction Site (check all that apply): Single-Family Residential
 Multi-Family Residential Commercial Industrial Institutional Highway or Road
 Utility Other _____

2.2 Discharge Information

Does your project/site discharge stormwater into a Municipal Separate Storm Sewer System (MS4)?

Yes No

Are there any surface waters that are located within 50 feet of your construction disturbances?

Yes No

Table 1 – Names of Receiving Waters

Name(s) of the first surface water that receives stormwater directly from your site and/or from the MS4 (note: multiple rows provided where your site has more than one point of discharge that flows to different surface waters)	
001.	Boston Inner Harbor

Table 2 – Impaired Waters / TMDLs (Answer the following for each surface water listed in Table 1 above)

	Is this surface water listed as “impaired” on the CWA303(d) list?	If you answered yes, then answer the following:			
		What pollutant(s) are causing the impairment?	Has a TMDL been completed?	Title of the TMDL document	Pollutant(s) for which there is a TMDL
001.	<input checked="" type="checkbox"/> YES <input type="checkbox"/> NO	Dissolved Oxygen, Enterococcus Bacteria, Fecal Coliform, PCB’s in Fish Tissue	<input type="checkbox"/> YES <input checked="" type="checkbox"/> NO		

Table 3 – Tier 2, 2.5, or 3 Waters (Answer the following for each surface water listed in Table 1 above)

	Is this surface water designated as a Tier 2, Tier 2.5, or Tier 3 water?	If you answered yes, specify which Tier (2, 2.5, or 3) the surface water is designated as?
001.	<input type="checkbox"/> YES <input checked="" type="checkbox"/> NO	

2.3 Nature of the Construction Activity

The project proposes the redevelopment of a dilapidated warehouse in the seaport neighborhood of Boston. The project site consists of an existing warehouse building and surface parking lot for freight trucks. It is bordered by northern Ave to the northeast, Harbor Street to the southeast, Channel Street to the southwest, and Haul Road to the northwest. The Ted Williams Tunnel runs beneath the northwestern corner of the site.

The redevelopment will consist of predominantly commercial office space and lab space. It will include an underground parking garage, and a pedestrian plaza with landscaping.

The structure was damaged during a winter storm in early 2021, resulting in the partial collapse of the structure. Demolition of the structure was requested for safety reasons.

Size of Construction Project

Size of Property: 4.2 acres

Total Area of Construction Disturbances: 5.5 acres

Maximum Area to be Disturbed at Any One Time: 5.5 acres

Construction Support Activities

Include a description of the construction support activities or reference Site Maps in Attachment A that include this information.

Contact Information for Construction Support Activity:

Name: XXX

Telephone: XXX-XXX-XXXX

Email: XXXX

Address and/or Latitude and Longitude:

Business Hours

Day-Day Xa.m-Xp.m.

2.4 Sequence and Estimated Dates of Construction Activities

Phase I: Name of Phase

- Description of Phase
- Schedule: Month, Day Year – Month, Day Year
- Area Disturbed During Phase: xx acres
- Description of stormwater controls that will be installed/maintained during phase

2.5 Allowable Non-Stormwater Discharges

List of Allowable Non-Stormwater Discharges Present at the Site

Type of Allowable Non-Stormwater Discharge	Likely to be Present at Your Site?
Discharges from emergency fire-fighting activities	<input checked="" type="checkbox"/> YES <input type="checkbox"/> NO
Fire hydrant flushings	<input checked="" type="checkbox"/> YES <input type="checkbox"/> NO
Landscape irrigation	<input checked="" type="checkbox"/> YES <input type="checkbox"/> NO
Waters used to wash vehicles and equipment, provided that there is no discharge of soaps, solvents, or detergents used for such purposes	<input type="checkbox"/> YES <input checked="" type="checkbox"/> NO
Water used to control dust	<input type="checkbox"/> YES <input checked="" type="checkbox"/> NO
Potable water including uncontaminated water line flushings	<input checked="" type="checkbox"/> YES <input type="checkbox"/> NO
External building washdown, provided soaps, solvents, and detergents are not used, and external surfaces do not contain hazardous substances (as defined in Appendix A of the CGP) (e.g., paint or caulk containing polychlorinated biphenyls (PCBs))	<input checked="" type="checkbox"/> YES <input type="checkbox"/> NO
Pavement wash waters, provided spills or leaks of toxic or hazardous substances have not occurred (unless all spill material has been removed) and where soaps, solvents, and detergents are not used.	<input type="checkbox"/> YES <input checked="" type="checkbox"/> NO
Uncontaminated air conditioning or compressor condensate	<input checked="" type="checkbox"/> YES <input type="checkbox"/> NO
Uncontaminated, non-turbid discharges of ground water or spring water	<input type="checkbox"/> YES <input checked="" type="checkbox"/> NO
Foundation or footing drains where flows are not contaminated with process materials such as solvents or contaminated groundwater	<input type="checkbox"/> YES <input checked="" type="checkbox"/> NO
Construction dewatering water discharged in accordance with Part 2.4 of the CGP	<input checked="" type="checkbox"/> YES <input type="checkbox"/> NO

Note: You are prohibited from directing pavement wash waters directly into any water of the U.S., storm drain inlet, or stormwater conveyance, unless the conveyance is connected to a sediment basin, sediment trap, or similarly effective control.

2.6 Site Maps

Refer to Attachment A

SECTION 3: DOCUMENTATION OF COMPLIANCE WITH OTHER FEDERAL REQUIREMENTS

3.1 *Endangered Species Protection*

Eligibility Criterion

Under which criterion listed in Appendix D of the CGP are you eligible for coverage under this permit?

A **B** **C** **D** **E**

For reference purposes, the eligibility criteria listed in Appendix D of the CGP are as follows:

Criterion A. No federally-listed threatened or endangered species or their designated critical habitat(s) are likely to occur in your site's "action area" as defined in Appendix A of the CGP.

Criterion B. The construction site's discharges and discharge-related activities were already addressed in another operator's valid certification of eligibility for your action area under eligibility Criterion A, C, D, E, or F and there is no reason to believe that federally-listed species or federally-designated critical habitat not considered in the prior certification may be present or located in the "action area". To certify your eligibility under this Criterion, there must be no lapse of NPDES permit coverage in the other operator's certification. By certifying eligibility under this Criterion, you agree to comply with any effluent limitations or conditions upon which the other operator's certification was based. You must include in your NOI the tracking number from the other operator's notification of authorization under this permit. If your certification is based on another operator's certification under Criterion C, you must provide EPA with the relevant supporting information required of existing dischargers in Criterion C in your NOI form.

Criterion C. Federally-listed threatened or endangered species or their designated critical habitat(s) are likely to occur in or near your site's "action area," and your site's discharges and discharge-related activities are not likely to adversely affect listed threatened or endangered species or critical habitat. This determination may include consideration of any stormwater controls and/or management practices you will adopt to ensure that your discharges and discharge-related activities are not likely to adversely affect listed species and critical habitat. To make this certification, you must include the following in your NOI: 1) any federally listed species and/or designated habitat located in your "action area"; and 2) the distance between your site and the listed species or designated critical habitat (in miles). You must also include a copy of your site map with your NOI.

Criterion D. Coordination between you and the Services has been concluded. The coordination must have addressed the effects of your site's discharges and discharge-related activities on federally-listed threatened or endangered species and federally-designated critical habitat, and must have resulted in a written concurrence from the relevant Service(s) that your site's discharges and discharge-related activities are not likely to adversely affect listed species or critical habitat. You must include copies of the correspondence between yourself and the Services in your SWPPP and your NOI.

Criterion E. Consultation between a Federal Agency and the U.S. Fish and Wildlife Service and/or the National Marine Fisheries Service under section 7 of the ESA has been concluded. The consultation must have addressed the effects of the construction site's discharges and discharge-related activities on federally-listed threatened or endangered species and federally-designated critical habitat. The result of this consultation must be either:

- i. a biological opinion that concludes that the action in question (taking into account the effects of your site's discharges and discharge-related activities) is not likely to jeopardize the continued existence of listed species, nor the destruction or adverse modification of critical habitat; or
- ii. written concurrence from the applicable Service(s) with a finding that the site's discharges and discharge-related activities are not likely to adversely affect federally-listed species or federally-designated habitat.

You must include copies of the correspondence between yourself and the Services in your SWPPP and your NOI.

Criterion F. Your construction activities are authorized through the issuance of a permit under section 10 of the ESA, and this authorization addresses the effects of the site's discharges and discharge-related activities on federally-listed species and federally-designated critical habitat. You must include copies of the correspondence between yourself and the Services in your SWPPP and your NOI.

For criterion A, indicate the basis for your determination that no federally-listed threatened or endangered species or their designated critical habitat(s) are likely to occur in your site's action area (as defined in Appendix A of the CGP). Check the applicable source of information you relied upon:

- Specific communication with staff of the U.S. Fish & Wildlife Service or National Marine Fisheries Service.
- Publicly available species list.
- Other source: NHESP data layer (August 2017 or as amended) from MassGIS, U.S. Fish and Wildlife online system Information for Planning and Conservation (IPaC) – Refer to Attachment K.

3.2 *Historic Preservation*

Appendix E (of the CGP), Step 1

Do you plan on installing any of the following stormwater controls at your site? Check all that apply below, and proceed to Appendix E, Step 2.

- Dike
- Berm
- Catch Basin
- Pond
- Stormwater Conveyance Channel (e.g., ditch, trench, perimeter drain, swale, etc.)
- Culvert
- Other type of ground-disturbing stormwater control: Water Quality Structures, Outlet Control Structure, Subsurface Infiltration System, Drain Manhole, Trench Drain, Area Drain

If you will not be installing any ground-disturbing stormwater controls, no further documentation is required for Section 3.2 of the Template.

Appendix E, Step 2

If you answered yes in Step 1, have prior cultural resource surveys or other evaluations determined that historic properties do not exist, or that prior disturbances at the site have precluded the existence of historic properties? YES NO

Refer to Attachment K Figure 4 for documentation of the basis of this determination.

3.3 ***Safe Drinking Water Act Underground Injection Control Requirements***

Do you plan to install any of the following controls? Check all that apply below.

- Infiltration trenches (if stormwater is directed to any bored, drilled, driven shaft or dug hole that is deeper than its widest surface dimension, or has a subsurface fluid distribution system);
- Commercially manufactured pre-cast or pre-built proprietary subsurface detention vaults, chambers, or other devices designed to capture and infiltrate stormwater flow; and
- Drywells, seepage pits, or improved sinkholes (if stormwater is directed to any bored, drilled, driven shaft or dug hole that is deeper than its widest surface dimension, or has a subsurface fluid distribution system)

If one or more of the above apply, then, INSERT COPIES OF LETTERS, EMAILS, OR OTHER COMMUNICATION BETWEEN YOU AND THE STATE AGENCY OR EPA REGIONAL OFFICE

SECTION 4: EROSION AND SEDIMENT CONTROLS REQUIREMENTS

Section 4 of this document describes the stormwater controls that will be implemented throughout construction. The operator must install and maintain all stormwater controls in compliance with Parts 2.2 and 2.3 of the CGP. The operator must install stormwater controls by the time construction activity in any given portion of the site begins.

The stormwater controls shall be designed and installed in accordance with good engineering practices and applicable design specifications. Specifications titled "312500- Erosion and Sedimentation Controls," dated 2/18/21 and prepared by Nitsch Engineering and details titled "Site Sedimentation & Erosion Control Plan," dated 2/18/21 and prepared by Nitsch Engineering have been provided to the contractor under separate cover.

4.1 *Natural Buffers or Equivalent Sediment Controls*

Buffer Compliance Alternatives

Are there any surface waters within 50 feet of your project's earth disturbances? YES NO

(Note: If no, no further documentation is required for Part 4.1 in the SWPPP Template. Continue to Part 4.2.)

4.2 *Perimeter Controls*

General

The site will be enclosed by a temporary construction fence as shown on the Site Sedimentation & Erosion Control Plan in Attachment A. Construction gates will be located at the entrance to the site as shown on the Site Sedimentation & Erosion Control Plan and all entrances will have stabilized construction entrances. All gates and entrances to the site will be secured during non-working hours. The areas of the site that will receive pollutant discharges will be surrounded by a Specific Perimeter Control listed below as shown on the the Site Sedimentation & Erosion Control Plan in Attachment A. Sediment tracked offsite must be removed by the end of the same workday.

Specific Perimeter Controls

Perimeter Control # 1

- BMP Description: Silt Fence with Wattles.
- Installation Schedule: Prior to the Start of Construction.
- Inspection Schedule: Once every 14 days and within 24 hours of a storm event 0.25" or greater.
- Maintenance: Ensure that all stormwater controls remain in effective condition as described in part 2.1.4 of the CGP. Remove any sediment before it has accumulated to one-half of the above-ground height of any perimeter control.
- Responsible Staff: Construction Manager and Site Contractor(s).

4.3 Sediment Track-Out

General

Gates will be located as shown on the Site Sedimentation & Erosion Control Plan in Attachment A to allow for construction vehicle access. Construction access points will have a stabilized construction entrance station or wheel wash station to minimize the track-out of sediment onto off-site streets, other paved areas, and sidewalks from vehicles exiting the construction site. Where sediment has been tracked out from your site onto paved roads, sidewalks, or other paved areas outside of your site, remove the deposited sediment by the end of the same business day in which the track-out occurs or by the end of the next business day if track-out occurs on a non-business day. Remove the track-out by sweeping, shoveling, or vacuuming these surfaces, or by using other similarly effective means of sediment removal. You are prohibited from hosing or sweeping tracked out sediment into any stormwater conveyance, storm drain inlet, or water of the U.S.

Specific Track-Out Controls

Track-Out Control # 1

- BMP Description: Stabilized Construction Entrance.
- Installation Schedule: Start of construction.
- Inspection Schedule: Once every 14 days and within 24 hours of a storm event 0.25" or greater.
- Maintenance: Ensure that all stormwater controls remain in effective condition as described in part 2.1.4 of the CGP.
- Responsible Staff: Construction Manager and Site Contractor(s).

4.4 Stockpiled Sediment or Soil

General

All soil stockpiles will be located outside of any natural buffers and away from existing and proposed catch basins and area drains and outside of proposed infiltration system footprints. A sediment barrier shall be installed along all downgradient perimeter areas. Examples of sediment barriers include silt fence, super silt fence, or wattles.

You are prohibited from hosing down or sweeping soil or sediment accumulated on pavement or other impervious surfaces into any stormwater conveyance, storm drain inlet, or water of the U.S.

For stockpiles that will be unused for 14 or more days, a cover such as a tarp or blown straw shall be provided or temporary stabilization should be provided (consistent with Part 2.2.14 of the CGP).

Specific Stockpile Controls

Stockpile Control # 1

- BMP Description: Silt Fence.
- Installation Schedule: Immediately after stockpile is established.
- Inspection Schedule: Once every 14 days and within 24 hours of a storm event 0.25" or greater.
- Maintenance: Ensure that all stormwater controls remain in effective condition as described in part 2.1.4 of the CGP. Remove any sediment before it has accumulated to one-half of the above-ground height of any perimeter control.
- Responsible Staff: Construction Manager and Site Contractor(s).

Stockpile Control # 2

- BMP Description: Wattles.
- Installation Schedule: Immediately after stockpile is established.
- Inspection Schedule: Once every 14 days and within 24 hours of a storm event 0.25" or greater.
- Maintenance: Ensure that all stormwater controls remain in effective condition as described in part 2.1.4 of the CGP.
Remove any sediment before it has accumulated to one-half of the above-ground height of any perimeter control.
- Responsible Staff: Construction Manager and Site Contractor(s).

Stockpile Control # 3

- BMP Description: Tarp.
- Installation Schedule: When stockpile will remain inactive for 14 or more calendar days.
- Inspection Schedule: Once every 14 days and within 24 hours of a storm event 0.25" or greater.
- Maintenance: Ensure that all stormwater controls remain in effective condition as described in part 2.1.4 of the CGP.
Remove any sediment before it has accumulated to one-half of the above-ground height of any perimeter control.
- Responsible Staff: Construction Manager and Site Contractor(s).

4.5 Minimize Dust

General

Disturbed land will be temporarily stabilized as required by the CGP. Dust will be minimized using measures including sprinkling/irrigation, vegetative cover, mulch, and/or stone. Stockpiles will be handled in accordance with section 4.4 of the SWPPP.

Earth-disturbing activities are considered temporarily ceased when work will not resume for a period of 14 or more calendar days. Stabilization shall be initiated when earth-disturbing activities are temporarily or permanently ceased. Stabilization activities shall be complete within 14 calendar days after the initiation of soil stabilization measures.

Specific Dust Controls

Dust Control # 2

- BMP Description: Straw or Mulch.
- Installation Schedule: As needed throughout earthwork activities as determined by the site contractor and construction manager. When disturbed land will remain inactive for 14 or more calendar days.
- Inspection Schedule: Once every 14 days and within 24 hours of a storm event 0.25" or greater.
- Maintenance: Ensure that all stormwater controls remain in effective condition as described in part 2.1.4 of the CGP.
- Responsible Staff: Construction Manager and Site Contractor(s).

4.6 *Minimize the Disturbance of Steep Slopes*

General

Steep slopes are defined as slopes of 15% or greater in grade. No steep slopes are proposed as part of this project. The EPA notes that the requirement to minimize disturbances to steep slopes does not apply to the creation of stockpiles.

4.7 *Preserve Native Topsoil*

Onsite native topsoil shall be preserved, unless infeasible. Preserving native topsoil is not required where the intended function of a specific area of the site dictates that the topsoil be disturbed or removed.

Stockpiling topsoil at off-site locations or transferring topsoil to other locations is an example of a way to preserve native topsoil.

The contractor shall perform construction sequencing such that earth materials are exposed for a minimum of time before they are covered, seeded, or otherwise stabilized.

4.8 *Minimize Soil Compaction*

General

In areas where infiltration practices will be installed or areas of the site where final vegetative stabilization will occur, soil compaction shall be minimized. This includes restricting vehicle access and equipment use.

Areas used for post-construction infiltration shall be constructed after all ground surfaces are fully stabilized when feasible. If proposed infiltration areas are constructed prior to the site being fully stabilized, additional erosion controls shall be installed. All stockpiled and material storage areas shall be located outside of the areas proposed for post-construction infiltration.

Areas of post-construction landscaping shall be constructed after all ground surface are fully stabilized. If proposed landscaped areas are constructed prior to the site being fully stabilized, additional erosion controls shall be installed. All soil stockpiles and material storage areas shall be located outside of the areas proposed for post-construction landscaping where feasible. Where this is not feasible, use techniques that rehabilitate and condition the soils as necessary to support vegetative growth prior to planting.

4.9 Storm Drain Inlets

General

All existing and proposed storm drain inlets affected by construction activities should be protected using an Inlet Sediment Filter as shown on the Site Sedimentation & Erosion Control Plan provided in Attachment A.

Clean or remove and replace the protection measures as sediment accumulates, the filter becomes clogged, and/or performance is compromised. Where there is evidence of sediment accumulation adjacent to the inlet protection measure, remove the deposited sediment by the end of the same business day in which it is found or by the end of the following business day if removal by the same business day is not feasible.

Specific Storm Drain Inlet Controls

Storm Drain Inlet Control # 1

- BMP Description: Inlet Sediment Filter.
- Installation Schedule: Prior to the Start of Construction.
- Inspection Schedule: Once every 14 days and within 24 hours of a storm event 0.25" or greater.
- Maintenance: Ensure that all stormwater controls remain in effective condition as described in part 2.1.4 of the CGP.
- Responsible Staff: Construction Manager and Site Contractor(s).

Storm Drain Inlet Control # 2

- BMP Description: Inlet Protection with Gravel.
- Installation Schedule: Prior to the Start of Construction .
- Inspection Schedule: Once every 14 days and within 24 hours of a storm event 0.25" or greater.
- Maintenance: Ensure that all stormwater controls remain in effective condition as described in part 2.1.4 of the CGP.
- Responsible Staff: Construction Manager and Site Contractor(s).

4.10 Minimize Erosion of Stormwater Conveyances

There are no proposed stormwater conveyance channels associated with this project.

4.11 Sediment Basins

There are no proposed sediment basins associated with this project.

4.12 Chemical Treatment

There are no proposed chemical treatments associated with this project.

4.13 Dewatering Practices

Dewatering will occur in a way that minimizes the discharge of pollutants in ground water or accumulated stormwater that is removed from excavations, trenches, foundations, vaults, or other similar points of accumulation. Dewatering water shall be treated in compliance with Section 2.4 of the CGP and water with visible floating solids or foam may not be discharged.

Any applicable permits shall be obtained from local permitting authorities.

Dewatering Control # 1

- BMP Description: Dewatering Tanks.
- Installation Schedule: Start of construction of stormwater conveyance channel.
- Inspection Schedule: Once every 14 days and within 24 hours of a storm event 0.25" or greater and as required by the manufacturer.
- Maintenance: Ensure that all stormwater controls remain in effective condition as described in part 2.1.4 of the CGP.
- Responsible Staff: Construction Manager and Site Contractor(s).

Dewatering Control # 2

- BMP Description: Filtration Systems.
- Installation Schedule: Start of construction of stormwater conveyance channel.
- Inspection Schedule: Once every 14 days and within 24 hours of a storm event 0.25" or greater and as required by the manufacturer.
- Maintenance: Ensure that all stormwater controls remain in effective condition as described in part 2.1.4 of the CGP.
- Responsible Staff: Construction Manager and Site Contractor(s).

4.14 Other Stormwater Controls

Any changes in construction activity that include means of stormwater control not included in this document will be identified, the SWPPP will be amended, and the appropriate erosion and sedimentation controls will be implemented.

4.15 Site Stabilization

Initiate the installation of stabilization measures immediately in any areas of exposed soil where construction activities have permanently ceased or will be temporarily inactive for 14 or more calendar days. Complete the installation of stabilization measures as soon as practicable, but no later than 14 calendar days after stabilization has been initiated.

Site Stabilization Practice #1

- Vegetative Non-Vegetative
 Temporary Permanent

- BMP Description: Soil Stabilization Mat.
- Installation Schedule: As/if required.
- Maintenance and Inspection: Once every 14 days and within 24 hours of a storm event 0.25" or greater.
- Responsible Staff: Construction Manager and Site Contractor(s).

SECTION 5: POLLUTION PREVENTION STANDARDS

5.1 *Potential Sources of Pollution*

Potential sources of sediment to stormwater runoff:

- Stockpiles and construction staging
- Clearing and grubbing operations
- Grading and site excavation
- Topsoil stripping
- Landscape operations
- Soil tracking offsite from construction vehicles
- Runoff from unstabilized areas
- Construction debris

Potential pollutants and sources, other than sediment, to stormwater runoff:

- Combined Staging Area – fueling activities, equipment maintenance, sanitary facilities, and hazardous waste storage
- Materials Storage Area – building materials, solvents, adhesives, paving materials, paints, aggregates, trash, etc.
- Construction Activity-paving, curb installation, concrete pouring, and building construction

Staging areas are shown on the Site Sedimentation & Erosion Control Plan provided in Attachment A.

Construction Site Pollutants

Pollutant-Generating Activity	Pollutants or Pollutant Constituents (that could be discharged if exposed to stormwater)	Location on Site (or reference SWPPP site map where this is shown)
Pesticides (insecticides, fungicides, herbicides, rodenticides)	Chlorinated hydrocarbons, organophosphates, carbonates, arsenic	Herbicides used for noxious weed control
Fertilizers	Nitrogen, phosphorous	Newly seeded areas
Plaster	Calcium sulphate, calcium carbonate, sulfuric acid	Building construction
Cleaning Solvents	Perchloroethylene, methylene chloride, trichloroethylene, petroleum distillates	No equipment cleaning allowed in project limits
Asphalt	Oil, petroleum distillates	Streets and parking lots
Concrete	Limestone, sand pH, chromium	Curb and gutter, sidewalk, building construction
Glue, Adhesives	Polymers, epoxies	Building construction
Paints	Metal oxides, Stoddard solvent, talc, calcium carbonate, arsenic	Building construction
Curing compounds	Naphtha	Curb and gutter, building construction
Wood preservatives	Stoddard solvent, petroleum distillates, arsenic, copper, chromium	Timber pads, bracing, building construction
Hydraulic Oils/fluids	Mineral oil	Leaks/broken hoses from equipment
Gasoline	Benzene, ethyl benzene, toluene, xylene, MTBE	Secondary containment/staging area
Diesel Fuel	Petroleum distillate, oil & grease, naphthalene, xylenes	Secondary containment/staging area
Kerosene	Coal oil, petroleum distillates	Secondary containment/staging area
Antifreeze/coolant	Ethylene glycol, propylene glycol, heavy metals (copper, lead, zinc)	Leaks or broken hoses from equipment
Sanitary toilets	Bacteria, parasites, and viruses	Staging area

5.2 *Spill Prevention and Response*

BMP Description: Spill kit, vehicle washing, silt sack catch basin protection, silt fence

Installation Schedule: Start of construction activity

Maintenance and Inspection: Minimum weekly & as necessary

Responsible Staff: Construction Manager and Site Contractor

- Major vehicle maintenance onsite is prohibited
- Re-fueling of vehicles within 25 feet of a drainage structure is prohibited
- Spill kit shall be kept onsite consisting of:
 - Gloves
 - Absorbent mats
 - Drip pan

Spill Prevention and Control Plan

- Refer to contractor's Spill Plan.
- Manufacturers' recommended spill control methods will be posted onsite and site personnel will be made aware of the requirements.
- Cleanup supplies will be kept onsite in a materials storage area. This equipment will include: goggles, brooms, dustpans, mops, rags, gloves, oil absorbent, sawdust, plastic and metal trash cans, and other materials and supplies specifically designated for cleanup.
- All spills will be immediately cleaned up after discovery.
- The spill area will be well ventilated.
- Cleanup personnel will wear suitable protective clothing.
- Spills of toxic and/or hazardous material will be reported to state, local, and Federal authorities, as required by law. Spills shall also be reported immediately to the owner.
- A spill incident report will be filed detailing the amount and extent of the spill, material(s) involved, and effectiveness of the cleanup. This report will be on file at the Construction Manager/Site Contractor office, as well as kept onsite in the field office. A copy shall also be filed with the Hazard Communication Coordinator (HCC).

The Construction Manager/Site Contractor will designate someone onsite that will serve as the Spill Cleanup Coordinator. At least two other personnel will be designated as alternate spill coordinators. All spill control personnel will be trained in spill prevention, control, and cleanup. The names of the responsible personnel will be posted at the jobsite office of the Construction Manager/ Site Contractor.

5.3 *Fueling and Maintenance of Equipment or Vehicles*

General

Minor vehicle and equipment emergency maintenance can be performed onsite away from drainage structures. Major vehicle and equipment maintenance must be performed offsite. Equipment/vehicle storage areas and any onsite fuel tanks will be inspected weekly and after storm events. Equipment and vehicles will be inspected for leaks, equipment damage, and other service problems on each day of use. Any leaks will be repaired immediately or the equipment/vehicle will be removed from the site.

Minor vehicle and equipment emergency maintenance shall occur when a vehicle cannot be safely removed from the site. The vehicle should be repaired so it can be taken off-site so that the rest of the maintenance can occur.

Major vehicle maintenance onsite is prohibited. Re-fueling or maintenance of vehicles within 25 feet of a drainage structure shall be prohibited. Drip pans, drip cloths, or absorbent pads should be used when replacing spent fluids. The fluids should be collect and stored prior to being disposed of offsite.

Specific Pollution Prevention Practice #1

- BMP Description: Spill Kit.
- Installation Schedule: Onsite throughout construction.
- Responsible Staff: Construction Manager and Site Contractor.

Specific Pollution Prevention Practice # 2

- BMP Description: Drip Pans, Drip Cloths, Absorbent Pads.
- Installation Schedule: Onsite throughout construction.
- Responsible Staff: Construction Manager and Site Contractor.

5.4 Washing of Equipment and Vehicles

General

Vehicle and equipment washout areas shall be constructed by the contractor so that no untreated water enters the storm drain system. Soaps, detergents, or solvents must be stored in a way to prevent these detergents from coming into contact with rainwater, or a similarly effective means designed to prevent the discharge of pollutants from these areas.

Specific Pollution Prevention Practices

Pollution Prevention Practice # 1

- BMP Description: Designated vehicle/equipment washing areas
- Installation Schedule: Start of construction.
- Inspection Schedule: Once every 14 days and within 24 hours of a storm event 0.25" or greater.
- Responsible Staff: Construction Manager and Site Contractor

Pollution Prevention Practice # 2

- BMP Description: Spill kit, vehicle washing, straw bale catch basin protection, silt fence
- Installation Schedule: Start of construction activity
- Inspection Schedule: Once every 14 days and within 24 hours of a storm event 0.25" or greater.
- Responsible Staff: Construction Manager and Site Contractor

5.5 Storage, Handling, and Disposal of Construction Products, Materials, and Wastes

5.5.1 **Building Products**

General

The contractor will recycle all construction materials possible. For materials that cannot be recycled, solid waste will be disposed of in accordance with DEP Regulations for Solid Waste Facilities, 310 CMR 10.00.

Any building materials required to be stored onsite will be stored at a combined staging and materials storage area as shown on the CMP. Larger items will be elevated by appropriate methods to minimize contact with runoff. The storage area will be inspected weekly and after storm events. It will be kept clean, organized, and equipped with appropriate cleaning supplies.

Building product usage shall follow the following good housekeeping BMPs:

- The Responsible Staff: Construction Manager or Site Contractor representative will inspect daily for inspection of the work area to ensure proper management of waste materials.
- Store only enough material onsite required for that job as to satisfy current construction needs.
- Store required materials in tightly lidded containers under cover.
- Store materials in original containers with clearly legible labels.
- Separate and store materials apart from each other.
- Do not mix materials unless specifically in accordance with manufacturers' recommendations.
- Use all products from a container before disposing of the container.
- Follow manufacturers' instructions for handling, storage, and disposing of all materials.
- All materials shall be stored in an area to prevent the discharge of pollutants from building products.

Specific Pollution Prevention Practices

Pollution Prevention Practice # 1

- BMP Description: Perimeter Protection control around Stockpiles.
- Installation Schedule: Start of construction/ Immediately after stockpile is established.
- Inspection Schedule: Once every 14 days and within 24 hours of a storm event 0.25" or greater.
- Maintenance: Ensure that all stormwater controls remain in effective condition as described in part 2.1.4 of the CGP. Remove any sediment before it has accumulated to one-half of the above-ground height of any perimeter control.
- Responsible Staff: Construction Manager and Site Contractor(s).

5.5.2 **Pesticides, Herbicides, Insecticides, Fertilizers, and Landscape Materials**

- In storage areas, provide either (1) cover to minimize the exposure of these chemicals to precipitation and to stormwater or (2) a similarly effective means designed to minimize the discharge of pollutants from these areas.
- Comply with all application and disposal requirements included on the registered pesticide, herbicide, insecticide, and fertilizer label.

5.5.3 Diesel Fuel, Oil, Hydraulic Fluids, Other Petroleum Products, and Other Chemicals

General

- Only skilled personnel in a designated area will perform fueling of vehicles onsite.
- Vehicles used onsite will be monitored for fuel and oil leaks.
- Vehicles used onsite will be maintained in good working order.
- Asphalt substances will be applied in accordance with manufacturers' recommendations.
- The use of petroleum products as a release agent for asphalt transport trucks is prohibited.
- Vehicle fueling will only be done in vehicle fueling areas located by the contractor. See section 5.3 of the SWPPP.
- The contractor shall be responsible for locating the fuel storage and re-fueling area onsite to minimize disturbance to construction activities and site area.
- Construction equipment not in active use for 5 minutes or more will be turned off.

5.5.4 Hazardous or Toxic Waste

(Note: Examples include paints, solvents, petroleum-based products, wood preservatives, additives, curing compounds, acids.)

General

- Keep products in their original containers.
- Original container labels should be clearly visible.
- Material safety data sheets will be kept onsite and be available.
- Follow all state, local, and Federal regulations regarding the handling, use, storage, and disposal of hazardous material.

Paints:

- All paint containers will be tightly sealed when not in use.
- Remove excess paint in original labeled containers from the jobsite.
- Paint will not be disposed of onsite. Remove excess paint material from the site and legally dispose of.
- Paint shall not be disposed of in the storm drain system.

5.5.5 Construction and Domestic Waste

General

The contractor will manage domestic waste onsite. The contractor will provide waste containers of sufficient size and number to contain construction and domestic wastes. The waste container lids will be kept closed when not in use and lids will be closed at the end of the business day for those containers that are actively used throughout the day. For waste containers that do not have lids, provide either a cover or a similarly effective means designed to minimize discharge of pollutants. Clean up immediately if containers overflow.

Pollution Prevention Practice # 1

- BMP Description: Dumpster.
- Installation Schedule: Start of construction.
- Maintenance and Inspection: Weekly and covered daily.
- Responsible Staff: Construction Manager and Site Contractor(s).

Pollution Prevention Practice # 2

- BMP Description: Litter/debris pick-up.
- Installation Schedule: Start of construction.
- Maintenance and Inspection: Daily.
- Responsible Staff: Construction Manager and Site Contractor(s).

5.5.6 Sanitary Waste

All sanitary waste portable toilets shall be positioned so that they are secure and will not be tipped or knocked over, and located away from any stormwater inlets or conveyances.

Pollution Prevention Practice # 1

- BMP Description: Porta John.
- Installation Schedule: Start of construction.
- Maintenance and Inspection: As manufacturer requires.
- Responsible Staff: Construction Manager and Site Contractor(s).

5.6 Washing of Applicators and Containers used for Paint, Concrete, or Other Materials

General

Washing of applicators and containers used for paint, concrete, or other materials shall follow the following good housekeeping BMPs:

- An effective means of eliminating the discharge of water from the washout and cleanout of stucco, paint, concrete, form release oils, curing compounds, and other construction materials.
- All washwater must be directed into a leak-proof container or leak-proof pit. The container or pit must be designed so that no overflows can occur due to inadequate sizing or precipitation.
- Washout and cleanout wastes should be handled as follows:
 - Do not dump liquid wastes into storm sewers.
 - Dispose of liquid wastes in accordance with applicable requirements.
 - Remove and dispose of hardened concrete waste consistent with the handling of other construction wastes.
- Locate any washout or cleanout activities as far away as possible from surface waters and stormwater inlets or conveyances, and to the extent practicable, designate areas to be used for these activities and conduct such activities only in these areas.

Pollution Prevention Practice # 1

- BMP Description: Designated applicator and container washing areas.
- Installation Schedule: Start of construction.
- Maintenance and Inspection: Daily.
- Responsible Staff: Construction Manager and Site Contractor(s).

5.7 Fertilizers

General

If fertilizer is required onsite, installation will follow the following guidelines:

- Fertilizers will be used at the application rates called for in the specifications for the project.
- Once applied, fertilizer will be worked into the soil to minimize wash off from irrigation and stormwater.
- Fertilizer will be stored under cover.
- The contents of partially used fertilizer bags will be transferred to re-sealable, watertight containers clearly labeled with their contents.
- Avoid applying before heavy rains.
- Never apply to frozen ground.
- Never apply to stormwater conveyance channels with flowing water.

5.8 Other Pollution Prevention Practices

Any changes in construction activity that produce other allowable non-stormwater discharges will be identified, the SWPPP will be amended and the appropriate erosion and sedimentation controls will be implemented.

Control # X

- BMP Description: Description of control to be installed.
- Installation Schedule: Approximate date of installation.
- Inspection Schedule: Pick Inspection schedule from above.
- Maintenance: Ensure that all stormwater controls remain in effective condition as described in part 2.1.4 of the CGP.
- Responsible Staff: Construction Manager and Site Contractor(s).

SECTION 6: INSPECTION AND CORRECTIVE ACTION

6.1 *Inspection Personnel and Procedures*

Personnel Responsible for Inspections

Construction Manager
Contact Person

Site Contractor
Contact person

(Note: All personnel conducting inspections must be considered a “qualified person.” CGP Part 4.1.1 clarifies that a “qualified person” is a person knowledgeable in the principles and practices of erosion and sediment controls and pollution prevention, who possesses the skills to assess conditions at the construction site that could impact stormwater quality, and the skills to assess the effectiveness of any stormwater controls selected and installed to meet the requirements of this permit.)

Inspection Schedule

Specific Inspection Frequency

The contractor shall inspect and maintain erosion control measures, and remove sediment therefrom, once every 14 days and within 24 hours of a storm event 0.25” or greater.

Rain Gauge Location:

NOAA Rain Gauge ID: GHCND:USW00014739

Lat/Long: 42.3606°, -71.0097°

Reductions in Inspection Frequency (if applicable):

Inspection frequency may be reduced to twice per month (no more than 14 days apart) for the first month in areas of the site where the stabilization steps outlined in Parts 2.2.14 of the CGP have been completed. After the first month, inspection frequency may be reduced to once per month. If construction activity resumes in this portion of the site at a later date, the inspection frequency immediately increases to that required in Parts 4.2 and 4.3 as applicable. You must document the beginning and ending dates of this period in the SWPPP.

Inspection frequency may be reduced to once per month and within 24 hours of the occurrence of a storm event of 0.25 inches or greater if the project is located in an arid, semi-arid, or drought-stricken area and construction is occurring during the seasonally dry period or a period in which drought is predicted to occur. If this inspection frequency is followed, you must document the beginning and ending dates of this period in the SWPPP.

Inspections can be temporarily suspended under the following conditions:

- Earth-disturbing activity is suspended due to frozen condition;
- Runoff is unlikely due to continuous frozen conditions that are likely to continue at the site for at least three months based on historic seasonal averaged. **If unexpected weather conditions make discharges likely, the operators must immediately resume the regular inspection schedule;**
- Land disturbances have been suspended; and
- All disturbed areas of the site have been stabilized in accordance with Part 2.2.14a of the CGP.

Inspection frequency may be reduced to once per month under the following conditions:

- The operator is still conducting earth disturbing activities under frozen conditions;
- Runoff is unlikely due to continuous frozen conditions that are likely to continue at the site for at least three months based on historic seasonal averages. **If unexpected weather conditions make discharges likely, the operator must immediately resume the regular inspection schedule;** and
- Except for areas in which the operator is conducting earth-disturbing activities, disturbed areas of the site have been stabilized in accordance with Part 2.2.14a of the CGP.

Inspection Report Forms

Copies of inspection reports are in Attachment D.

6.2 Corrective Action

Personnel Responsible for Corrective Actions

Contact Person, Construction Manager Company

Contact Person, Site Contractor

Corrective Action Forms

A copy of the Corrective Action Form is in Attachment E.

6.3 Delegation of Authority

Duly Authorized Representative(s) or Position(s):

Construction Manager Company

Contact Person

Contact Person Title

Street Address

Town/City, State Zip Code

xxx-xxx-xxxx

Email address

SECTION 8: CERTIFICATION AND NOTIFICATION

Operator – Owner’s Representative

I certify under penalty of law that this document and all attachments were prepared under my direction or supervision in accordance with a system designed to assure that qualified personnel properly gathered and evaluated the information submitted. Based on my inquiry of the person or persons who manage the system, or those persons directly responsible for gathering the information, the information submitted is, to the best of my knowledge and belief, true, accurate, and complete. I have no personal knowledge that the information submitted is other than true, accurate, and complete. I am aware that there are significant penalties for submitting false information, including the possibility of fine and imprisonment for knowing violations.

Name: _____ Title: _____

Signature: _____ Date: _____

Operator – Construction Manager

I certify under penalty of law that this document and all attachments were prepared under my direction or supervision in accordance with a system designed to assure that qualified personnel properly gathered and evaluated the information submitted. Based on my inquiry of the person or persons who manage the system, or those persons directly responsible for gathering the information, the information submitted is, to the best of my knowledge and belief, true, accurate, and complete. I have no personal knowledge that the information submitted is other than true, accurate, and complete. I am aware that there are significant penalties for submitting false information, including the possibility of fine and imprisonment for knowing violations.

Name: _____ Title: _____

Signature: _____ Date: _____

SWPPP ATTACHMENTS

Attachment A – Site Maps

Attachment B – 2017 Construction General Permit

Attachment C – NOI and EPA Authorization Email

Attachment D – Inspection Form

Attachment E – Corrective Action Form

Attachment F – SWPPP Amendment Log

Attachment G – Subcontractor Certifications/Agreements

Attachment H – Grading and Stabilization Activities Log

Attachment I – SWPPP Training Log

Attachment J – Delegation of Authority Form

Attachment K – Endangered Species Documentation

Attachment L – Historic Preservation Documentation

Attachment M – Rainfall Gauge

Attachment N – Order of Conditions

Attachment A – Site Maps

Attachment B – 2017 Construction General Permit

Attachment C – NOI and EPA Authorization e-mail

Attachment D – Inspection Form

Attachment E – Corrective Action Form

Attachment F – SWPPP Amendment Log

Attachment G –Subcontractor Certifications/Agreements

**SUBCONTRACTOR CERTIFICATION
STORMWATER POLLUTION PREVENTION PLAN**

Project Number: _____

Project Title: _____

Operator(s): _____

As a subcontractor, you are required to comply with the Stormwater Pollution Prevention Plan (SWPPP) for any work that you perform onsite. Any person or group who violates any condition of the SWPPP may be subject to substantial penalties or loss of contract. You are encouraged to advise each of your employees working on this project of the requirements of the SWPPP. A copy of the SWPPP is available for your review at the office trailer.

Each subcontractor engaged in activities at the construction site that could impact stormwater must be identified and sign the following certification statement:

I certify under the penalty of law that I have read and understand the terms and conditions of the SWPPP for the above designated project and agree to follow the practices described in the SWPPP.

This certification is hereby signed in reference to the above named project:

Company: _____

Address: _____

Telephone Number: _____

Type of construction service to be provided: _____

Signature: _____

Title: _____

Date: _____

Attachment H – Grading and Stabilization Activities Log

Attachment I – SWPPP Training Log

Stormwater Pollution Prevention Training Log

Project Name:

Project Location:

Instructor's Name(s):

Instructor's Title(s):

Course Location: _____ Date: _____

Course Length (hours): _____

Stormwater Training Topic: *(check as appropriate)*

- Sediment and Erosion Controls**
- Emergency Procedures**
- Stabilization Controls**
- Inspections/Corrective Actions**
- Pollution Prevention Measures**

Specific Training Objective: _____

Attendee Roster: *(attach additional pages as necessary)*

No.	Name of Attendee	Company
1		
2		
3		
4		
5		
6		
7		
8		

Attachment J – Delegation of Authority Form

Delegation of Authority

I, _____ (name), hereby designate the person or specifically described position below to be a duly authorized representative for the purpose of overseeing compliance with environmental requirements, including the Construction General Permit, at the _____ construction site. The designee is authorized to sign any reports, stormwater pollution prevention plans and all other documents required by the permit.

_____ (name of person or position)
_____ (company)
_____ (address)
_____ (city, state, zip)
_____ (phone)

By signing this authorization, I confirm that I meet the requirements to make such a designation as set forth in Appendix I of EPA's Construction General Permit (CGP), and that the designee above meets the definition of a "duly authorized representative" as set forth in Appendix I.

I certify under penalty of law that this document and all attachments were prepared under my direction or supervision in accordance with a system designed to assure that qualified personnel properly gathered and evaluated the information submitted. Based on my inquiry of the person or persons who manage the system, or those persons directly responsible for gathering the information, the information submitted is, to the best of my knowledge and belief, true, accurate, and complete. I am aware that there are significant penalties for submitting false information, including the possibility of fine and imprisonment for knowing violations.

Name: _____
Company: _____
Title: _____
Signature: _____
Date: _____

Attachment K – Endangered Species Documentation

Attachment L – Historic Preservation Documentation

Attachment M – Rainfall Gauge Recording

Use the table below to record the rainfall gauge readings at the beginning and end of each work day. An example table follows.

Month/Year			Month/Year			Month/Year		
Day	Start time	End time	Day	Start time	End time	Day	Start time	End time
1			1			1		
2			2			2		
3			3			3		
4			4			4		
5			5			5		
6			6			6		
7			7			7		
8			8			8		
9			9			9		
10			10			10		
11			11			11		
12			12			12		
13			13			13		
14			14			14		
15			15			15		
16			16			16		
17			17			17		
18			18			18		
19			19			19		
20			20			20		
21			21			21		
22			22			22		
23			23			23		
24			24			24		
25			25			25		
26			26			26		
27			27			27		
28			28			28		
29			29			29		
30			30			30		
31			31			31		

Attachment N – Order of Conditions

APPENDIX G

Soil Investigations

NRCS Soil Maps and Descriptions

Soil Map—Norfolk and Suffolk Counties, Massachusetts

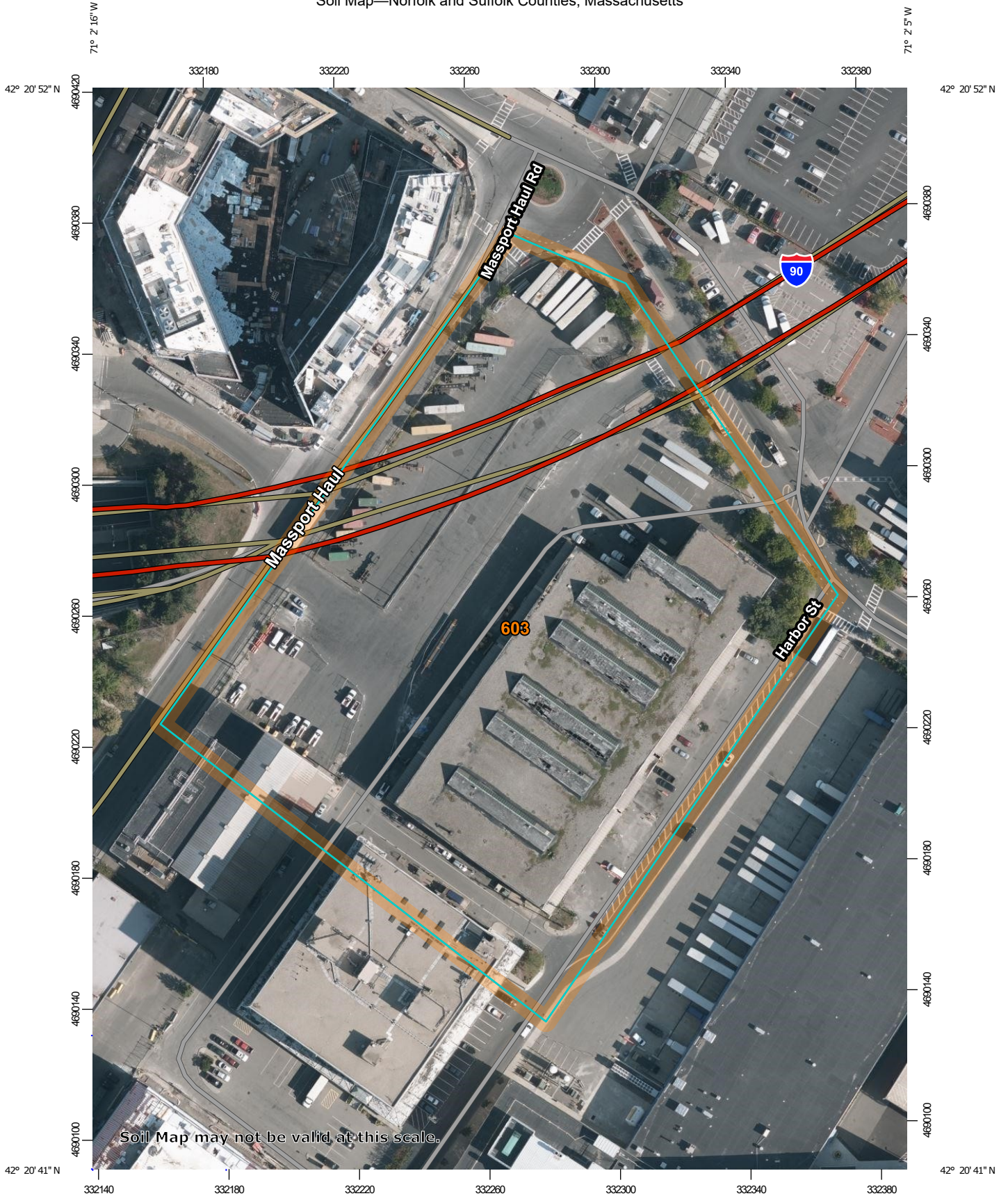

Map Scale: 1:1,610 if printed on A portrait (8.5" x 11") sheet.

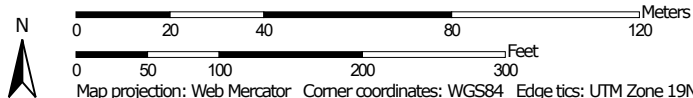

Map projection: Web Mercator Corner coordinates: WGS84 Edge tics: UTM Zone 19N WGS84



MAP LEGEND

Area of Interest (AOI)

 Area of Interest (AOI)

Soils

 Soil Map Unit Polygons

 Soil Map Unit Lines

 Soil Map Unit Points

Special Point Features



Blowout



Borrow Pit



Clay Spot



Closed Depression



Gravel Pit



Gravelly Spot



Landfill



Lava Flow



Marsh or swamp



Mine or Quarry



Miscellaneous Water



Perennial Water



Rock Outcrop



Saline Spot



Sandy Spot



Severely Eroded Spot



Sinkhole



Slide or Slip



Sodic Spot



Spoil Area



Stony Spot



Very Stony Spot



Wet Spot



Other



Special Line Features

Water Features



Streams and Canals

Transportation



Rails



Interstate Highways



US Routes



Major Roads



Local Roads

Background



Aerial Photography

MAP INFORMATION

The soil surveys that comprise your AOI were mapped at 1:25,000.

Warning: Soil Map may not be valid at this scale.

Enlargement of maps beyond the scale of mapping can cause misunderstanding of the detail of mapping and accuracy of soil line placement. The maps do not show the small areas of contrasting soils that could have been shown at a more detailed scale.

Please rely on the bar scale on each map sheet for map measurements.

Source of Map: Natural Resources Conservation Service

Web Soil Survey URL:

Coordinate System: Web Mercator (EPSG:3857)

Maps from the Web Soil Survey are based on the Web Mercator projection, which preserves direction and shape but distorts distance and area. A projection that preserves area, such as the Albers equal-area conic projection, should be used if more accurate calculations of distance or area are required.

This product is generated from the USDA-NRCS certified data as of the version date(s) listed below.

Soil Survey Area: Norfolk and Suffolk Counties, Massachusetts

Survey Area Data: Version 16, Jun 11, 2020

Soil map units are labeled (as space allows) for map scales 1:50,000 or larger.

Date(s) aerial images were photographed: Sep 11, 2019—Oct 5, 2019

The orthophoto or other base map on which the soil lines were compiled and digitized probably differs from the background imagery displayed on these maps. As a result, some minor shifting of map unit boundaries may be evident.

Map Unit Legend

Map Unit Symbol	Map Unit Name	Acres in AOI	Percent of AOI
603	Urban land, wet substratum, 0 to 3 percent slopes	6.5	100.0%
Totals for Area of Interest		6.5	100.0%

Norfolk and Suffolk Counties, Massachusetts

603—Urban land, wet substratum, 0 to 3 percent slopes

Map Unit Setting

National map unit symbol: vkyl

Mean annual precipitation: 32 to 50 inches

Mean annual air temperature: 45 to 50 degrees F

Frost-free period: 120 to 200 days

Farmland classification: Not prime farmland

Map Unit Composition

Urban land: 85 percent

Minor components: 15 percent

Estimates are based on observations, descriptions, and transects of the mapunit.

Description of Urban Land

Setting

Parent material: Excavated and filled land over herbaceous organic material and/or alluvium and/or marine deposits

Minor Components

Udorthents

Percent of map unit: 13 percent

Hydric soil rating: Unranked

Beaches

Percent of map unit: 2 percent

Hydric soil rating: Unranked

Data Source Information

Soil Survey Area: Norfolk and Suffolk Counties, Massachusetts

Survey Area Data: Version 16, Jun 11, 2020

APPENDIX H

Porous Asphalt System Design Information



University of New Hampshire Stormwater Center

2012 Biennial Report



Contents

Directors' Message	3
Highlights	4
Field Research Site	8
Focus Area	10
Stormwater Treatment System Data	
Porous Asphalt	12
Pervious Concrete	14
Permeable Interlocking Concrete Pavement	16
Subsurface Gravel Wetland	18
Bioretention Systems	20
Tree Box Filter	22
Detention Ponds	24
Offline Hydrodynamic Separators	26
Maintenance	28
Targeted Research	30
Administration	34

About the Center

The University of New Hampshire Stormwater Center (UNHSC) is dedicated to the protection of water resources through effective stormwater management. The Center has four main focus areas: 1) BMP Performance Testing, 2) Targeted Research, 3) Outreach and Education, and 4) Design and Implementation. Center researchers examine and refine the performance of stormwater treatment systems to treat the pollution in stormwater runoff and reduce the flooding that it can cause. Targeted research examines cold climate performance, cost, design, maintenance, and other information needed to advance the practice and understanding of stormwater science. This research provides information which is then integrated into an outreach program for stormwater managers and professionals who seek to build programs that protect water quality, preserve environmental values, and reduce the impact of stormwater runoff. The Center receives funding and program support from the Cooperative Institute for Coastal and Estuarine Environmental Technology (CICEET), a partnership of UNH and the National Oceanic and Atmospheric Administration (NOAA), and other federal, state, and private sources. It is housed within the University's Environmental Research Group, a division of the College of Engineering and Physical Sciences.

Resources for Stormwater Managers

The Center's research has served as the foundation for a range of outreach products—from best management practice (BMP) workshops geared to support municipal decision makers and stormwater engineers to peer-reviewed publications that explore the frontiers of stormwater science. Learn more about these resources at www.unh.edu/unhsc/.

- Data Reports
- Design Specifications
- Fact Sheets
- Case Studies
- Journal Articles
- Web Resources





Directors' Message

This is a bittersweet report to issue. The roots of the UNHSC were in our stormwater studies in the early 1990's that were trying to follow-up on the conclusions of the original studies included in the National Urban Runoff Program (NURP). In fact, one of the field sites we studied in the 1990's was one of the original NURP sites in Durham, NH. Those studies made it clear that a more holistic approach to evaluating the performance of stormwater management strategies was warranted. In 2002, we formally founded the Stormwater Center, located a large field site on the University of New Hampshire campus, designed and then constructed a full field facility. Afterwards, I brought onboard a full time Director, Rob Roseen. Rob masterfully oversaw our original site construction and as Director, fostered UNHSC initiatives in outreach and research. Rob has taken on a new opportunity in the private sector, we will miss him and we wish him all the best.

Some of the fundamental reasons for creating a field research facility that could do parallel testing of stormwater management technologies were to: develop field protocols; obtain performance metrics for LID systems; and to assist manufacturers in bringing technologies to market. These objectives are still timely and salient. Many regulatory agencies still struggle with protocols for field-based acceptance and verification of stormwater treatment device performance. One only needs to look at the very few systems that have been certified under national protocols to see there is still much work to do. In addition, because of the need to remove more than just sediment, proprietary systems are rapidly being proposed to meet the permit needs of communities (for example nutrient reduction),

yet very little performance information exists for the new technologies. Even when considering some basic changes to bioretention systems (soil amendments, internal water storage volumes, etc.), little has found its way into design guidance. Nationwide, thousands of these systems will be constructed each year with very few monitored to verify that they are meeting performance expectations. As such, we rely on the long term performance results of actual field installations to guide the design and selection of stormwater management.

In this our tenth year of operation, the UNHSC renews its commitment to advancing the field and science of stormwater management. We will also continue to offer and improve on our outreach and training. For example, because of the documented performance of the UNHSC subsurface gravel wetland system, states like New Jersey are recommending this practice in watersheds with nutrient impairments. In the past year we offered three subsurface gravel wetland and permeable pavement workshops throughout the state of New Jersey to strengthen the design capacity as well as to provide regulators, designers, and contractors with the most recent and updated information on these systems. Over the next two years we expect to continue to expand our outreach offerings.

This present, 2012 biennial report has some fantastic findings to present to you on stormwater system performance, cost, maintenance, and education. We hope the information is useful to you, and as always, we enjoy hearing back from you.

Sincerely,

Thomas Ballestero
Director

Highlights from 2010 & 2011

Water Quality and Economic Benefits for a Commercial LID Application at Greenland Meadows

The Greenland Meadows project demonstrates both economic and water quality benefits of LID structural controls in a high-use commercial application. The use of porous asphalt, standard pavements, and a sub-surface gravel wetland produced exceptional water quality benefits and resulted in substantial savings in stormwater infrastructure in comparison to conventional design.

Greenland Meadows is a retail shopping center built in Greenland, N.H., in 2008 by Newton, MA.- based New England Development and was designed by Tetra Tech Rizzo in collaboration with the UNH Stormwater Center, the New Hampshire Department of Environmental Services, and the Conservation Law Foundation. The site features innovative stormwater management including numerous LID structural designs. Located on a 56-acre parcel, the development includes three retail buildings (Lowe's Home Improvement, Target, and a yet-to-be-built supermarket), paved parking areas consisting of porous asphalt and non-porous pavements, landscaped areas, a large subsurface gravel wetland, as well as advanced proprietary treatment systems. The total impervious area of the development – mainly from rooftops and non-porous parking areas – is approximately 25.6 acres. Prior to this development, the project site contained an abandoned light bulb factory with the majority of the property vegetated with grass and trees.

During the permitting stage, concerns arose about potential adverse water quality impacts from the development. The building project would increase the amount of impervious surface on the site, resulting in increased runoff and higher pollutant load to Pickering Brook, an impaired waterway that connects to the Great Bay. This impairment required a very high-level of treatment for project permitting.

Two porous asphalt lots totaling 4.5 acres were installed at Greenland Meadows, one in the main parking lot and one in the eastern parking area. These systems contain a reservoir and filter course that provides peak flow attenuation, extended detention, and filtration. The porous pavement discharges to a large gravel wetland designed as a series of flow-through treatment cells; providing an anaerobic system of crushed stone with wetland soils and plants. This innovative LID design works to remove pollutants with especially effective treatment of nutrients while also mitigating the thermal impacts of stormwater.

Starting in 2007, a wet weather flow monitoring program was implemented to assess background conditions for Pickering Brook, evaluate stormwater quality runoff from the project site, and determine the resultant water quality of Pickering Brook downstream from Greenland Meadows. The program includes:

- pre-construction monitoring (phase one),
- construction activity monitoring (phase two), and
- 5 years of post-construction monitoring (phase three)

Pollutant analyses include total suspended solids (TSS), total petroleum hydrocarbons-diesel (TPH-D), total nitrogen (NO3, NO2, NH4, TKN), and total metals (Zn). Additional analytes such as total phosphorus and ortho-phosphate have been added due to their relative importance in stormwater effluent characteristics. To date, the median TSS, TN, and TP concentrations for the post-construction treated runoff are below pre-construction monitoring concentrations and significantly below concentrations found in the receiving waters of Pickering Brook. Monitoring results indicate that the stormwater management systems are operating well providing a high level of treatment for runoff originating from a high pollutant load commercial site, and offering significant protection to the impaired receiving waters of Pickering Brook. Water quality results show that effluent pollutant levels leaving the site at the gravel wetland are typically at or below ambient stream concentrations across a wide range of contaminants. In addition, baseflow benefits, while not yet quantified, are observed discharging in a manner similar to shallow groundwater discharge, providing a nearly continuous source of cool, clean baseflow from the site.

A comparison of the total construction cost estimates for the conventional and the LID options revealed that although porous paving costs were estimated to be considerably more expensive (\$884,000), there were substantial savings (\$1,743,000) associated with earthwork and reduced infrastructure primarily due to piping for storage. Overall the LID alternative was estimated to save a total of \$930,000 or 26 percent of the total cost for stormwater management.



Summary Water Quality Results from 2007-2011

	Post-Construction	Pre-Construction	Pickering Brook
Total Suspended Solids	2 mg/l	5 mg/l	10 mg/l
Total Nitrogen	0.65 mg/l	0.55 mg/l	1.15 mg/l
Total Phosphorus	0.008 mg/l	0.05 mg/l	0.045 mg/l

Forging the Link: Linking the Economic Benefits of Low Impact Development and Community Decisions

Through a series of case studies, this project documents the advantages of LID in the economic terms of how municipal land use decisions are commonly made. In addition to the environmental and water quality benefits for which LID is so commonly known, considerable economic, infrastructure, and adaptation planning benefits are also being realized through the incorporation of LID-based strategies. Forging the Link (FTL) demonstrates the substantive economic benefits for both construction budgets and project life-cycle costs that are increasingly being observed by municipalities, commercial developers, and others when using Green Infrastructure for stormwater management. In addition, the FTL curriculum demonstrates the use of LID as a means for building community resiliency to changing climates in a water resources management context.

The FTL curriculum demonstrates:

1. The ecological benefits of LID with respect to water quality, aquatic habitat, and watershed health protection
2. The economic benefits of using both traditional and innovative infrastructure to manage stormwater
3. The capability of LID to be used as a climate change adaptation planning tool which can minimize stress to urban stormwater infrastructure.

One example study is Boulder Hills, located in Pelham, NH. This project led to simplified permitting and a 6% reduction in project costs using widespread use of LID designs. A comparison of project costs is listed below.

Comparison of Material Unit Cost			
Item	Conventional	LID	Difference
Site Preparation	\$23,200	\$18,000	-\$5,200
Temp. Erosion Control	\$5,800	\$3,800	-\$2,000
Drainage	\$92,400	\$20,100	-\$72,300
Roadway	\$82,000	\$128,000	\$46,000
Driveways	\$19,700	\$30,100	\$10,400
Curbing	\$6,500	\$0	-\$6,500
Perm. Erosion Control	\$70,000	\$50,600	-\$19,400
Additional Items	\$489,700	\$489,700	\$0
Buildings	\$3,600,000	\$3,600,000	\$0
Project Total	\$4,389,300	\$4,340,300	-\$49,000



Restoring Water Quality in the Willow Brook Watershed Through LID Retrofits

Willow Brook is a small stream that is a tributary to the Cocheco River in the urban center of Rochester, NH. This small urban stream is impaired for Primary and Secondary Contact Recreation (e. coli). Its direct receiving waters, the Cocheco River, are impaired for Aquatic Life Use (benthic macroinvertebrates and habitat) as well as Primary Contact Recreation (e.coli). Sources are nonpoint source pollutants from urban stormwater runoff. The Cocheco River Watershed Coalition (CRWC) in cooperation with the City of Rochester Public Works Dept.(DPW), and the UNH Stormwater Center (UNHSC) developed a plan for installation of LID practices, including outreach and educational activities. The project implemented two retrofit demonstration projects for reducing effective impervious cover. The project was funded through NHDES 319 Watershed Assistance Grants to address nonpoint source pollution from urban runoff.



The first demonstration location was a small K-4 neighborhood school lacking any stormwater management, which directly impacted the usability of the surrounding playground. The project included the implementation of eight different LID retrofit strategies, eliminating 96% of direct runoff from the site's impervious areas. These strategies included raingardens (3), a dry well, rainbarrels, pervious concrete sidewalks, and a porous asphalt basketball court made possible by a donation from Pike Industries. The second demonstration location was a residential subdivision with conventional curb, catch basins, and gutters. Retrofits included a rain garden and two tree filters to effectively disconnect roughly 65% of the site's impervious cover. In order to document the positive impact of these retrofit demonstrations the amount of pollution removed by the treatment strategies was modeled and the results presented in the table below. In this case impervious cover (IC) is considered disconnected when runoff is treated through an adequately sized stormwater control measure.

Willow Brook Watershed Pollutant Load Summary	
Drainage Area (AC)	2515
2011 BMP Retrofit Reductions in Lbs Per Year	
TSS #/year	593
TP #/year	2
TN #/year	18
2011 IC Reductions	
	0.8 acres
	0.2%

2011 Road Management Plan for Brackett and Pond Roads, Wakefield, NH



In June of 2011, the Acton Wakefield Watershed Alliance and the UNHSC completed a road management plan for the north shore of Lovell Lake in Wakefield, NH. The purpose of the Road Management Plan (RMP) was to address declining water quality of Lovell Lake caused by runoff from gravel roads

which carry sediment and phosphorus. Unimproved roads are commonplace in the Lakes Region of New Hampshire in an area with a substantial seasonal population. Unimproved roads and associated maintenance are well documented as major sources of sediment and phosphorus in surface water and may account for as much as 80% of the sediment load and 40% of the phosphorus load within a watershed. Studies have shown that during high intensity storm events, sediment concentrations may be observed to exceed 100,000 mg/L with averages for gravel roads greater than 3,000 mg/L due to erosion and unstable drainage. When compared to sediment concentrations from a typical low-use paved road of 100 mg/L it is clear that erosion can be a dramatic source of pollution. Impacts from sediment laden waters can be substantial, directly affecting the value, aesthetics, and usability of the lakes. As seasonal populations grow and become permanent, the number of roads and driveways will increase maintenance demands for these unimproved surfaces.

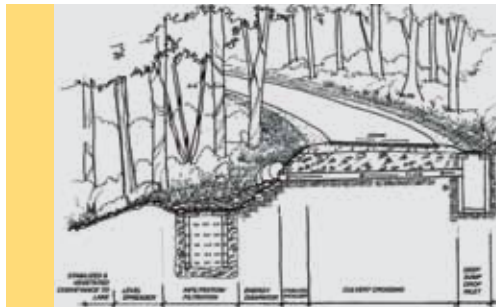

Another issue of concern is that road maintenance practices, while intended to improve road drainage, often contribute significantly to erosion and sedimentation. An example is the process of improving roadside conveyance through ditching, which is a routine and a necessary element

of road maintenance. Implementing erosion and sedimentation control practices to this routine maintenance will reduce the threat to surface waters. A range of strategies exist to reduce impacts including practical road maintenance techniques, road and drainage improvements, and non-structural approaches (i.e. catch basin cleaning, vegetative stabilization) targeted to minimize erosion and sedimentation. Structural approaches in this report include the use of dry wells, sedimentation and infiltration basins, hooded deep sump catch basins, and stabilized channels.

Urban Watershed Renewal in Berry Brook

During 2011, water quality and stream restoration improvements began in the Berry Brook Watershed located in Dover, NH. A tributary to the Cocheco River, Berry Brook is a 0.9 mile long stream in an approximately 180 acre watershed in downtown Dover that is almost completely built-out with 30.1% impervious cover. The Project Team includes the City of Dover, the UNHSC, the Cocheco River Watershed Coalition, New Hampshire Fish and Game, NH Department of Environmental Services, and American Rivers. The Brook is impaired for aquatic life use (i.e. habitat) and primary contact recreation. Watershed improvements included a combination of LID stormwater management and stream restoration initiatives.



In the first year of this two year project, the UNHSC restored and enhanced the headwaters of Berry Brook, an existing 2 acre wetland, by creating approximately 3.2 additional acres of wetland/floodplain. This now 5+ acre wetland is located at the Dover Water Works site on Lowell Avenue and discharges to a newly-created 1,000-foot stream channel. This stream channel was piped underground as the site was developed for the City of Dover municipal water supply dating back to 1908. The project restored a winding channel from the wetland to reestablish the upper channel. The enhanced wetland and stream channel will improve water quality and habitat functions as well as create a vibrant green space in the heart of the watershed.

In addition, over 11 BMP installations were implemented throughout the watershed from subsurface gravel wetlands to rain gardens. Combined, these installations provide treatment for approximately 24 acres of impervious area and reduced suspended sediment, phosphorous and nitrogen pollution by 16,800, 58, and 387 pounds per year respectively. A Community outreach program was also initiated which included watershed and stormwater education activities at the Horne Street School, a Community Meeting, homeowner workshops, stormwater audits, a residential rain garden installation, a homeowner rain barrel implementation project, and a watershed clean-up.

Future activities in the Berry Brook watershed include additional outreach activities, improvements to the lower Berry Brook stream where it connects to the Cocheco River, and additional planting and invasives maintenance. Future efforts also include monitoring of ecosystem response for a range of parameters which include nutrients, bacteria, metals, flow, temperature, fish and macroinvertebrates.



Portsmouth Tree Filter Project

An emerging body of research supports the use of tree box filters to treat stormwater pollution in urban areas. Tree box filters are high-flow filters that require smaller footprints than bioretention systems yet level treatment. Tree filters are a combination of stormwater drainage and urban forestry. In many ultra-urban environments trees have very short lives, particularly due to stress from lack of nutrients and water. Tree filters are available as proprietary and non-proprietary versions, both of which have advantages for either cost or level of effort required for design.

This project was part of the State Street Redesign in Portsmouth, NH, a combined sewer separation, which included the use of numerous tree filters and other forms of advanced stormwater management. The project was led by CMA Engineers partnering with the UNHSC for the LID design and the project received the Outstanding Civil Engineering Achievement Award for 2010 by the New Hampshire Section of the American Society of Civil Engineers.

Performance monitoring will be used to assess the effectiveness of tree filters in a high-use municipal setting for removing common stormwater pollutants. Water quality results are similar to the tree box filter studied at the UNHSC with good sediment, hydrocarbons, metals and phosphorus removal. Anticipated cost benefits will be examined for both the value of urban forestry and pollutant load reductions. Targeted outreach activities are expected to improve confidence and knowledge in communities in regards to the benefits of incorporating trees for stormwater management in urban areas. These assessments and other project information will be shared through outreach and education activities, products such as a guidance manual for communities, a training workshop, case-study fact sheets, and presentations.

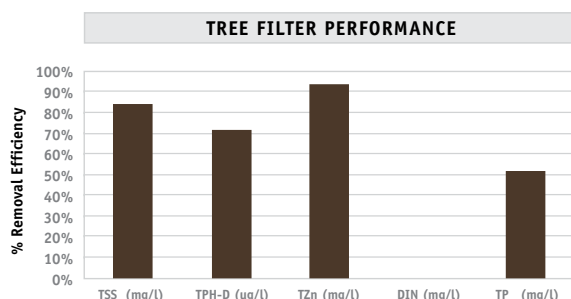

Nutrient Management in Barnegat Bay and Subsurface Gravel Wetlands

In support of the New Jersey Environmental Infrastructure Financing Program's (NJEIFP) Barnegat Bay Initiative, the New Jersey Department of Environmental Protection (NJDEP) in cooperation with UNHSC developed a gravel wetland specification targeting nitrogen removal from existing and new developments. The specification can be found at: http://www.njstormwater.org/pdf/gravel_wetlands_barnegat_bay.pdf

In the Spring of 2012, the UNHSC, NJDEP, Rutgers Cooperative Extension, Barnegat Bay Partnership, Coastal Training Program at Jacques Cousteau National Estuarine Research Reserve, and the New Jersey Water Resources Research Institute offered regional workshops to train local engineers and water resource management professionals in regards to gravel wetland design.

The subsurface gravel wetland is a recent innovation in LID stormwater design. It approximates the look and function of a natural wetland, effectively removing sediments and other pollutants commonly found in runoff while enhancing the visual appeal of the landscape by adding buffers, or greenscape, to urban areas. The subsurface gravel wetland evaluated and recommended by the UNHSC is a horizontal-flow filtration system, and should not be confused with stormwater wetlands that function more like ponds. Instead, the subsurface gravel wetland includes a dense root mat, crushed stone reservoir, and an anaerobic, microbe-rich environment to improve water quality. Like other filtration systems, it demonstrates a tremendous capacity to reduce peak flow and improve water quality. The subsurface gravel wetland is unique in its ability to remove up to 82% of nitrogen during summer months and is recommended in some states for nutrient impaired waterbodies.



Field Research Site

The UNHSC's primary field research facility sits adjacent to a nine-acre commuter parking lot in Durham, N.H. The contributing drainage area—curbed and almost completely impervious—generates runoff typical of a commercial development. For nine months of the year, this lot is used near capacity by a combination of passenger vehicle and bus traffic. The pavement is frequently plowed, salted, and sanded during the winter.

The facility is designed to provide an “apples-to-apples” comparison of water quality treatment and water quantity management performance. A range of stormwater systems is installed in a parallel yet separate configuration that normalizes the variability inherent in stormwater contaminant loading and rainfall. Each system is uniformly sized to address a Water Quality Volume (WQ_v) of runoff generated by one inch of rainfall off one acre of impervious surface.

The facility contains three classes of stormwater treatment systems: conventional, structural systems such as swales and ponds; LID designs such as bioretention cells and subsurface gravel wetlands; and manufactured systems such as hydrodynamic separators and subsurface infiltration and filtration systems.

The lot's contaminant concentrations are above, or equal to, national norms for commercial parking lot runoff. The local climate is coastal, cool temperate forest, with an average annual precipitation of 44 inches and monthly averages of 3.7 inches. The mean annual temperature is 48°F, with averages of 15.8°F in January and 82°F in July. The design depth for frost penetration is 48 inches.

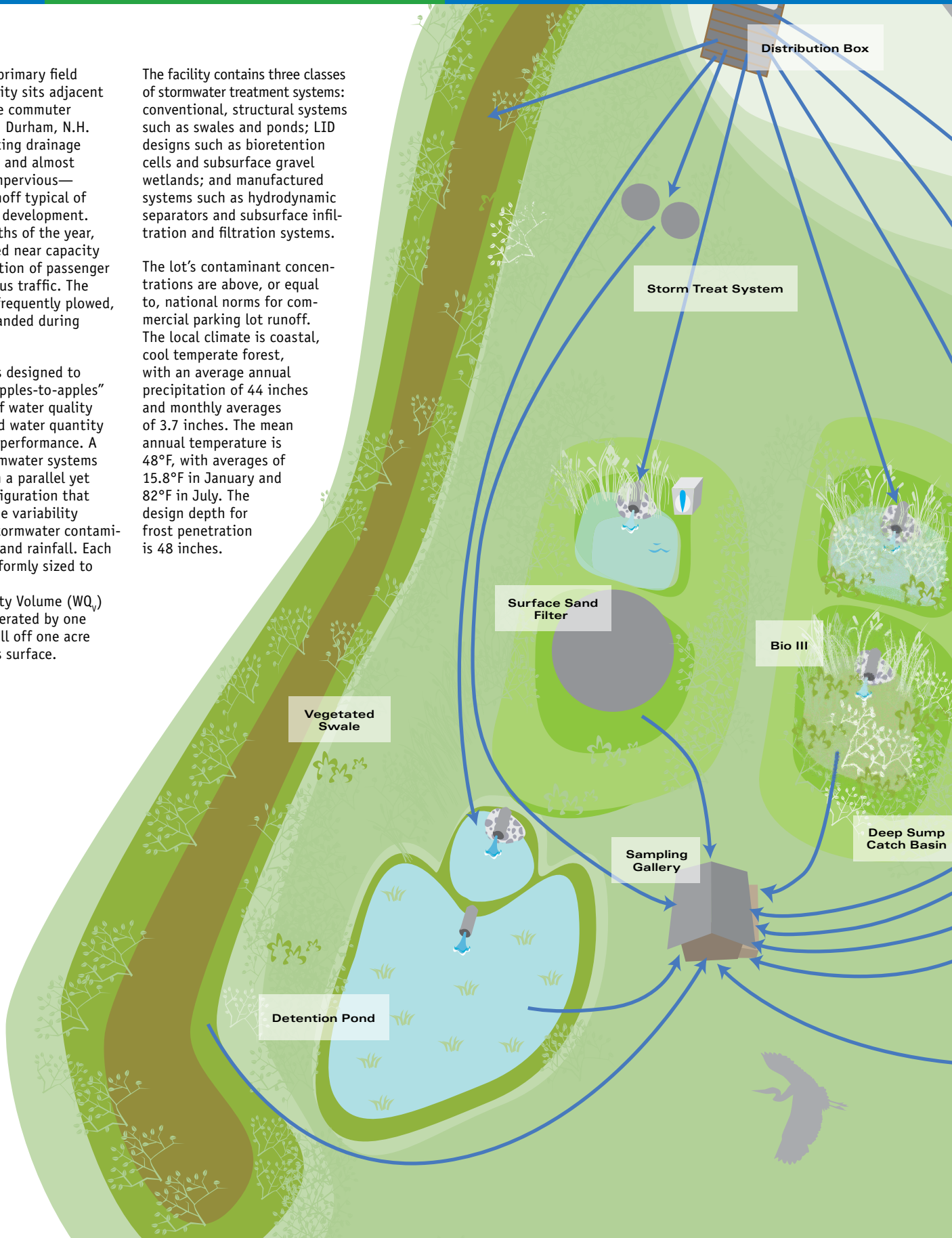

How We Evaluate Performance

A detailed quality assurance project protocol governs all UNHSC's methods, procedures, maintenance tasks, and analyses related to the evaluation of stormwater treatment systems. All systems are installed with an impermeable liner so that researchers can provide a strict accounting of the runoff flowing through the systems, as well as the contaminants it contains.

Here's How Our Performance Evaluation Process Works

1. Stormwater runoff from the parking lot is channeled into a 36-inch pipe where it is monitored in real time for flow, pH, conductivity, dissolved oxygen, temperature, and turbidity. Concurrently, automated devices collect flow-weighted samples of runoff throughout the runoff hydrograph. These samples are processed and evaluated for a range of contaminants, or frozen for future evaluation.
2. Runoff then flows into a distribution box with a floor that rests slightly higher than the invert of the outlets that direct runoff to the various stormwater treatment systems. This configuration insures that runoff will scour the floor of the box, thereby preventing sediment accumulation. Baffles and flow splitters help to distribute the runoff evenly among systems.
3. From the distribution box, runoff flows through a network of pipes and into each system.
4. Runoff moves through the stormwater treatment systems.
5. Runoff leaves the systems through perforated subdrains and is conveyed into a sampling gallery.
6. In the gallery, runoff is monitored in real time for the same characteristics monitored in step one. Concurrently, automated devices collect flow-weighted samples of runoff throughout the runoff hydrograph. These samples are evaluated for the same range of contaminants as step one, thereby serving as the basis for system performance evaluation.

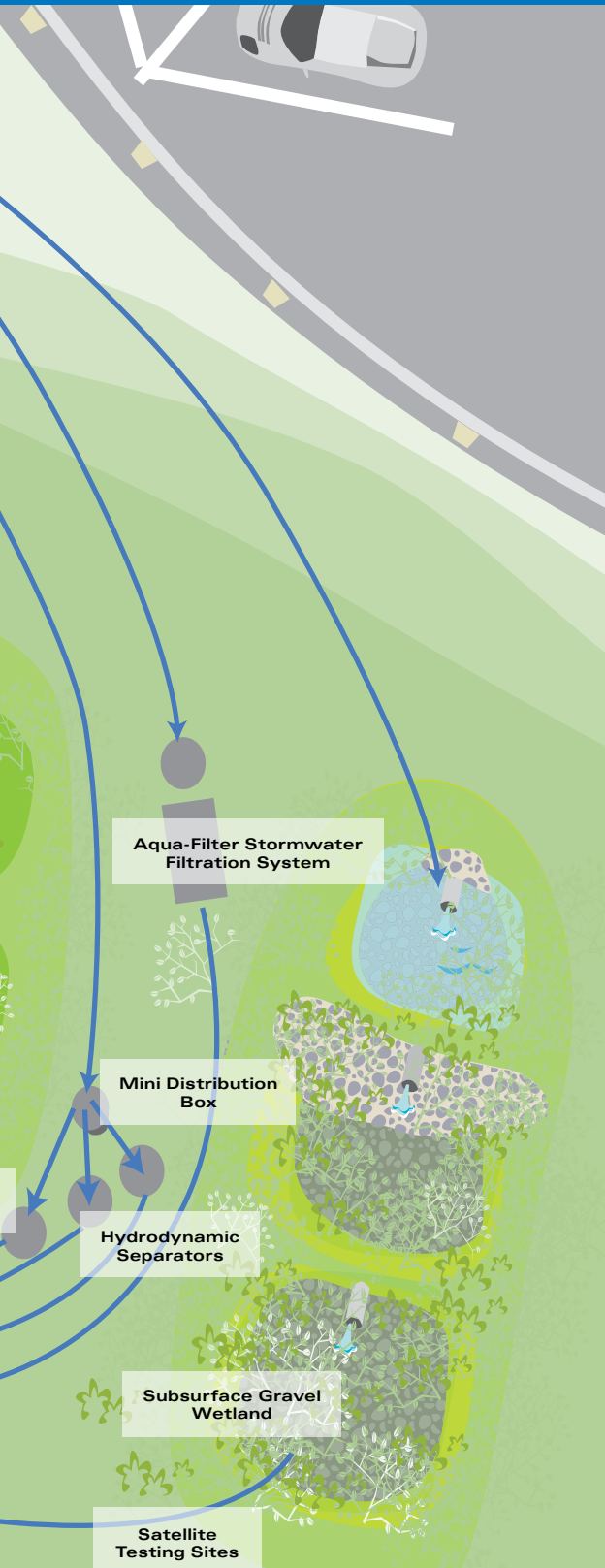
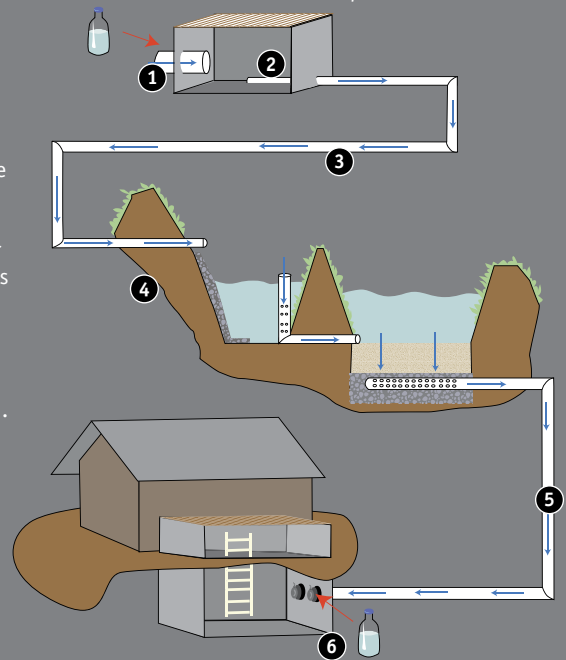

In addition to its main field facility UNHSC also conducts monitoring on numerous satellite systems including porous asphalt, pervious concrete, permeable interlocking concrete pavement, bioretention, tree filters, and gravel wetlands.

Focus Area: Concentration, Volume, and Pollutant Load Reduction

Accurate data on stormwater best management practice (BMP) performance is critical for estimating pollutant removal efficiency, determining compliance with regulations and planning for effective strategies that sustain precious water resources. Engineers, municipal officials, scientists, and regulators routinely use BMP performance data. To this end, it is important to understand how performance efficiency, volume reduction by recharge, and load reduction interrelate.

By its nature, stormwater quality and BMP performance information can be confusing. Point source discharges are often predictable in contrast to non-point sources of pollution which can be highly variable. BMP performance is influenced by both system variables (size, design, installation, and maintenance) and site variables (land use, soil type, local climate, and vegetation). System variables such as filter media type, vegetation, hydraulic loading rate, and residence time, too name a few, will affect performance efficiency (removal of pollutants) and the resulting effluent concentration. Site variables, particularly soil type and local climate, will determine the amount of groundwater recharge and the reduction of runoff volume moving overland to surface waters.

Choosing appropriate BMPs can be a challenge to meet local regulations and address pollutants of concern.

Pollutant load reductions associated with individual BMP removal efficiencies coupled with load reductions from infiltration both lead to removal of pollutant mass. In system designs that incorporate LID treatment and infiltration, pollutant mass removal should be calculated by viewing the design as a system-in-series, or a treatment train approach, according to the following equation:

$$\text{Mass Removed} = V_t \times RE \times C_{in} + (V_r) \times (1-RE) \times C_{in}$$

Where:

V_t = the total volume of runoff from the watershed to the stormwater management system

V_r = the volume of runoff reduced (infiltrated)

RE = the Removal Efficiency associated with the BMP

C_{in} = the concentration of the pollutant entering into the BMP

The first of these two products is the mass of pollutant removed in the stormwater management system and the second of the product terms is the mass removed in the infiltrated water. It should be recognized that ultimately this infiltrated mass could show up in receiving waters depending on the pollutant of concern.

In terms of the percent removal efficiency based on mass, the combined removal efficiency for a stormwater management and then infiltration practice is: $RE_t = RE + (1- RE) \%I$

Where RE is defined as before, and:

RE_t = the total (or combined) removal efficiency

$\%I$ = the percent of runoff infiltrated.

Removal efficiency is a common way to represent BMP performance. It is also a misapplied concept. The graphic below illustrates mass load removals for nitrogen over a range of BMPs with varying removal efficiencies and volume reduction potentials. The following example illustrates common misunderstandings

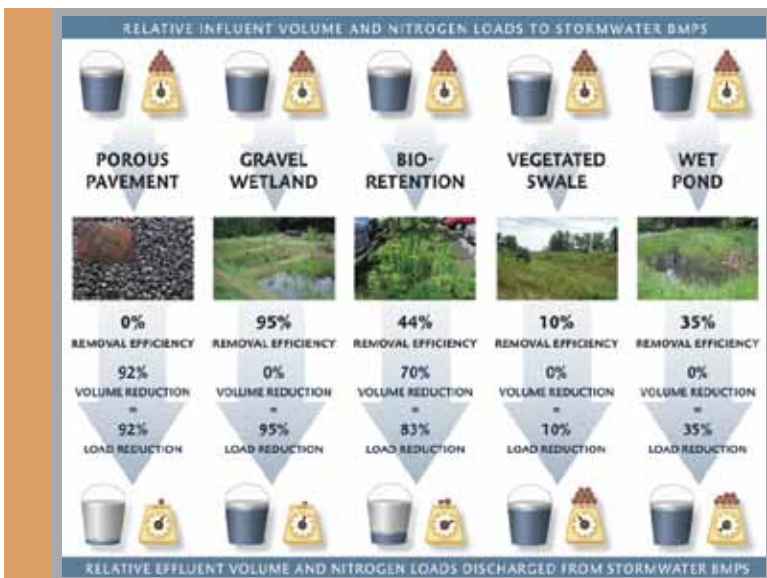

UNHSC Measured Median Pollutant Removal Efficiencies

Treatment Unit Description	TSS Total Suspended Solids (mg/l)			TPH-D Total Petroleum Hydrocarbons in the Diesel Range (ug/l)			NO3-N (DIN) Dissolved Inorganic Nitrogen (mg/l)			TZn Total Zinc (mg/l)			TP Total Phosphorus (mg/l)			Average Annual Peak Flow Reduction	Average Annual Lag Time
	Influent	Effluent	% Removal	Influent	Effluent	% Removal	Influent	Effluent	% Removal	Influent	Effluent	% Removal	Influent	Effluent	% Removal	% Reduction	Minutes
Conventional Treatment Technologies																	
Retention Pond	55	30	68%	710	100	82%	0.3	0.2	33%	0.05	0.01	68%	0.09	0.11	NT	86	455
Detention Pond	77	16	79%	490	165	74%	0.3	0.2	25%	0.03	0.02	50%	0.05	0.05	NT	93	639
Stone (rip-rap) Swale	30	15	50%	580	380	33%	0.4	0.7	NT	0.07	0.02	64%	-	-	-	6	7
Vegetated Swale	48	16	56%	710	207	82%	0.3	0.3	NT	0.04	0.02	40%	0.08	0.10	NT	52	38
Berm Swale	51	23	50%	637	61	81%	0.2	0.3	NT	0.03	0.02	50%	0.07	0.09	NT	16	58
Deep Sump Catch Basin	48	34	9%	510	440	14%	0.2	0.3	NT	0.04	0.04	NT	0.08	0.07	NT	NT	NT
Manufactured Treatment Devices																	
ADS Infiltration Unit	49	BDL	99%	766	BDL	99%	0.3	0.9	NT	0.05	BDL	99%	0.12	0.02	81%	87	228
StormTech	87	13	83%	750	45	91%	0.3	0.5	NT	0.03	0.01	67%	0.07	0.03	52%	78	235
Aquifer	28	11	62%	573	156	66%	0.3	0.3	NT	0.04	0.02	43%	0.07	0.05	24%	NT	NT
Online Hydrodynamic Separators	41	29	29%	774	442	42%	0.4	0.4	NT	0.05	0.04	26%	0.09	0.11	NT	NT	NT
Offline Hydrodynamic Separators (HDS)	120	21	75%	570	180	64%	0.2	0.3	NT	0.03	0.02	21%	0.05	0.05	NT	NT	NT
Low Impact Development (LID)																	
Surface Sand Filter	45	19	51%	788	17	98%	0.3	0.4	NT	0.06	0.01	77%	0.12	0.06	33%	69	187
Bio I - 48" depth (42" filter depth)	37	1	97%	798	BDL	99%	0.4	0.1	44%	0.07	BDL	99%	-	-	-	75	266
Bio II - 30" depth (24" filter depth)	48	6	87%	750	BDL	99%	0.2	0.2	NT	0.04	0.02	73%	0.08	0.05	34%	79	309
Bio III - 30" depth (24" filter depth)	120	8	91%	450	163	64%	0.4	0.3	44%	0.03	0.01	75%	0.03	0.05	NT	84	216
Bio IV - 37" depth (24" filter depth)	80	11	83%	495	165	65%	0.3	0.2	42%	0.03	0.01	67%	0.07	0.06	NT	95	61
Subsurface Gravel Wetlands	61	4	96%	644	BDL	99%	0.3	0.1	75%	0.04	0.01	84%	0.06	0.02	58%	92	391
Porous Asphalt	32	BDL	99%	631	BDL	99%	0.2	0.5	NT	0.04	0.01	75%	0.08	0.04	57%	82	1,275
Pervious Concrete	101	11	85%	310	BDL	99%	0.3	0.5	NT	0.03	0.01	75%	0.06	0.65	NT	93	1,011
Permeable Interlocking Concrete Pavement	51	BDL	99%	610	BDL	99%	0.4	BDL	99%	0.05	BDL	99%	0.13	BDL	99%	99	see pg 16
Tree Filter	31	2	91%	631	BDL	99%	0.2	0.2	1%	0.04	0.01	75%	0.07	0.06	NT	31	204

*BDL indicates a value that is Below Detection Limit of the test method.
NT indicates no treatment.

Porous Asphalt



Porous asphalt use is on the rise and innovations in designs, materials, and mixes advance every year. This improved market means that more asphalt manufacturers are making porous asphalt in response to more designers specifying the product.

About Porous Asphalt

Porous asphalt (PA) is a very effective approach to stormwater management in terms of both quality and quantity. Unlike retention ponds, PA systems do not require large amounts of additional space. The marginal cost between standard and porous asphalt is typically less than the associated drainage infrastructure (curb, catch basins, piping, and ponds) for standard impervious pavements. With PA, rainfall filters through the system and infiltrates back into the ground, which significantly reduces runoff volume, lowers peak flows, decreases temperatures, and improves water quality. PA also speeds snow and ice melt and virtually eliminates black ice development, reducing salt requirements for winter maintenance.

Porous asphalt, like most LID stormwater practices, is suitable for a wide range of locations. Its usage typically includes parking lots, driveways, sidewalks, low-use roadways, and developments with large areas of impervious surface. As with any infiltration system, care must be taken when locating these systems near pollution hotspots, or in areas of seasonal high groundwater. The effectiveness of porous asphalt has been demonstrated over a wide range of climates, including those with winter freezing and thawing. Studies at UNH have shown PA to be especially effective in cold

climates given its durability and capacity to reduce the salt needed for deicing in winter conditions. Improvements in PA mix design and installation practices are continually advancing. This combined with added requirements for infiltration, and higher stormwater quality treatment standards make PA a reasonable stormwater management alternative. Clogging, poor mix specifications, structural failure, and other historical barriers to implementation have by and large been overcome. Successful implementation of porous asphalt systems relies on proper design, siting, mix production, construction, installation, and maintenance—all of which can be achieved with qualified suppliers, experienced installers, and engineering oversight. While porous asphalt has been proven to manage stormwater effectively, it is weaker than conventional asphalt pavements. However with the proper admixtures and design, PA durability can be greatly improved and has been shown to be effective for both commercial and roadway applications.

System Performance

Cost

The 2004 materials and installation cost associated with UNHSC's porous asphalt lot were approximately \$2,300 per space, compared to \$2,000 per space for the adjacent impervious

FAST FACTS	CATEGORY / BMP TYPE Porous Pavement, Low Impact Development Design	Water Quality: Physical (Filtration) & Chemical (Sorptions)	SPECIFICATIONS Catchment Area: 5,500 sf	MAINTENANCE Maintenance Sensitivity: Low
	UNIT OPERATIONS & PROCESSES Hydrologic (Flow Alteration and Volume Reduction/ Infiltration)	DESIGN SOURCE UNHSC	Water Quality Volume: 435 cf	Inspections: 1-4 times per year
		BASIC DIMENSIONS Surface Area: 5,200 sf	INSTALLATION COST 2008 Costs: \$2.80/sf for porous asphalt compared with \$2.25/sf for standard asphalt	Sediment Removal: High

Surface Infiltration Rates for Porous Pavements Over Time

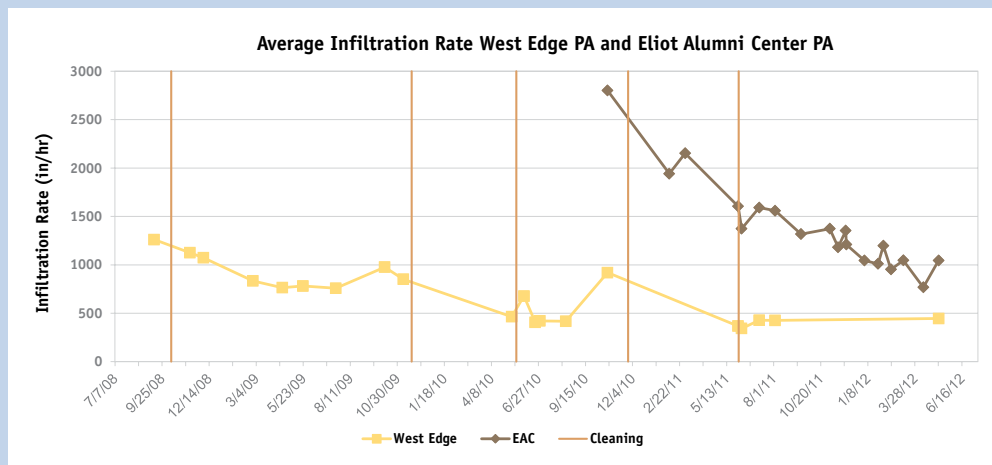

After ensuring proper design and installation of PA, clogging is likely to be a major issue of concern with respect to the long term maintenance and system performance. Infiltration rates (IR) of porous asphalts are generally orders of magnitude higher than design rainfall intensities and surrounding soils. Even for a worst case "no maintenance" scenario, infiltration rates will remain high enough such that there should be no significant runoff from common storm events. Clogging can be defined as the loss of the initial infiltration capacity to such an extent that runoff or ponding occurs on portions of the surface that did not originally exhibit such conditions.

asphalt lot. The net costs for both pavements would have been comparable had the impervious pavement's stormwater infrastructure been taken into consideration. Between 2008 and 2009, costs for porous asphalt materials and installation ranged from \$2.80 and \$3.17 per square foot compared to \$2.30 to \$3.32 per square foot for standard asphalt. Cost variations are primarily due to the use of admixtures. Cost does not include preparatory site work and subbase construction which may range from \$2-4 per square foot.

Maintenance

Longterm PA operation and performance requires two distinct maintenance elements: 1) inspections, at least once a year to examine surface infiltration rates, and 2) street vacuuming 2-4 times per year to remove solids and debris and keep void spaces open. Vacuuming costs are commonly \$350-500 per acre. PA carries one of the lowest maintenance burden's observed among the systems studied at UNHSC and has remained consistent and predictable over the years as depicted in the graph at the bottom right.

Winter plowing for PA should be routine and requires no special blade or adjustments. PA was observed to require only 25% of the salt routinely applied to impervious asphalt to achieve equivalent, or better, deicing and traction in winter. Black ice from melting and refreezing is essentially eliminated on porous asphalt. However, the need for winter maintenance on porous asphalt may increase in some cases, in particular for compacted snow and ice. That said over a two year period at the UNHSC PA yielded a net reduction of road salt when compared to applications necessary on conventional pavements. A winter maintenance fact sheet is available online: www.unh.edu/unhsc.

The graph shows two different porous asphalt systems and tracks infiltration rates (IR) over time. Maintenance events, in this case with a regenerative air vacuum, are tracked over time alongside IR. The prevention of clogging through routine cleaning and vacuuming should be standard and is the best way to ensure longevity and performance.

In the two examples, initial decline in IR is rapid, but over time the rate of decline diminishes. In the case of the West Edge parking lot, the average IR of the PA is approximately 500 in/hr, 8 years post installation. For the Elliot Alumni Center parking lot, a much more recent installation, the IR is approximately 1000 in/hr after 2 years of operation.

Cold Climate

With winter surface infiltration rates of more than 1,000 inches an hour cold climate performance of PA systems remain excellent during winter despite observed frost penetration to depths of 27 inches. The pavement froze sooner, deeper, and thawed more rapidly than adjacent ground conditions. A well-drained frozen pavement retains porosity and infiltration capacity. When designed with a deep subbase, the lifespan of these pavements are expected to exceed conventional impervious asphalt pavements, which tend to lose structural integrity in northern climates due to frost heaving.

Water Quality Treatment

Porous pavements can be expected to have substantial pollutant load reduction. The amount of load reduction is dependent on the degree of volume reduction and treatment efficiency relative to the pollutant of concern. The water quality treatment performance of the PA lot generally has been excellent. It consistently exceeds EPA's recommended level of removal of total suspended solids and meets regional ambient water quality criteria for petroleum hydrocarbons and zinc. The exceptionally high level of treatment is due in part to the use of a filter course in the subbase design. Systems that specify only coarse aggregate layers have more of an infiltration and sedimentation function. The finer gradation of the filter course layer is designed for improved pollutant removal and delayed discharge. For nutrient treatment capacity some phosphorus reductions were observed however, there was no treatment for nitrogen consistent with results from other non-vegetated infiltration systems. The system, like all other systems tested, did not remove chloride. However, since it drastically reduced the amount of salt needed for winter maintenance, it may prove effective at reducing chloride pollution. The chart at the top right reflects the system's performance in removing total suspended solids, total petroleum hydrocarbons, total zinc, dissolved inorganic nitrogen, total nitrogen, and total phosphorus. Values represent results recorded over four years, with the data further divided into summer and winter components.

Water Quantity Control

The porous asphalt system's ability to manage runoff has been exceptional. It has generally outperformed all systems tested at UNHSC in its capacity to reduce runoff volume. No surface runoff has been observed from this lot since its installation in 2004; this includes the 100-year storm events that New Hampshire experienced in 2006 and 2007. Groundwater recharge was observed to be 25% of annual rainfall despite the system's location over clay soils. The graph in the middle right illustrates effective peak flow reduction and long lag times for the range of seasons monitored.

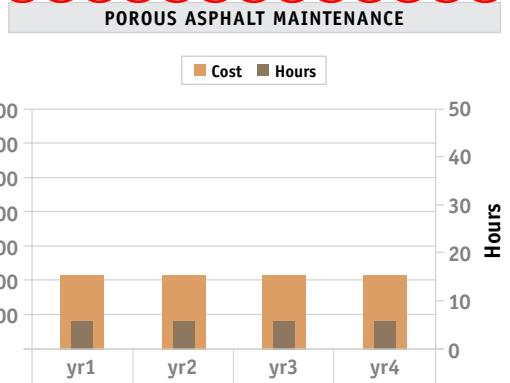
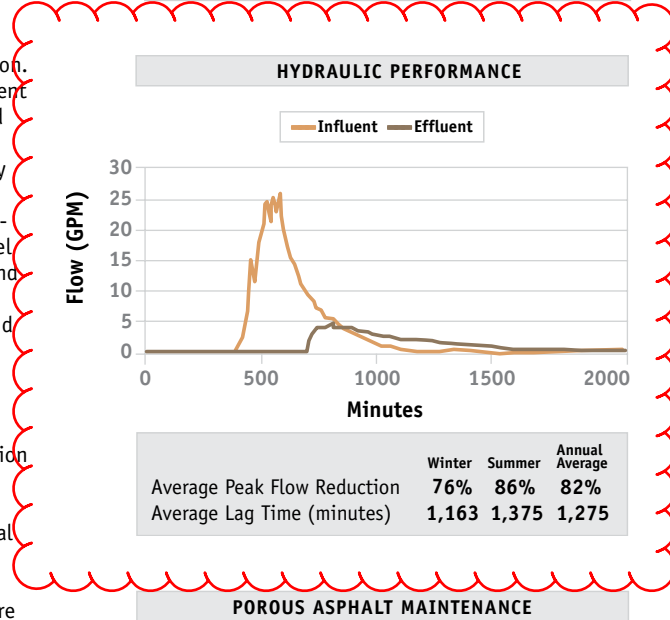
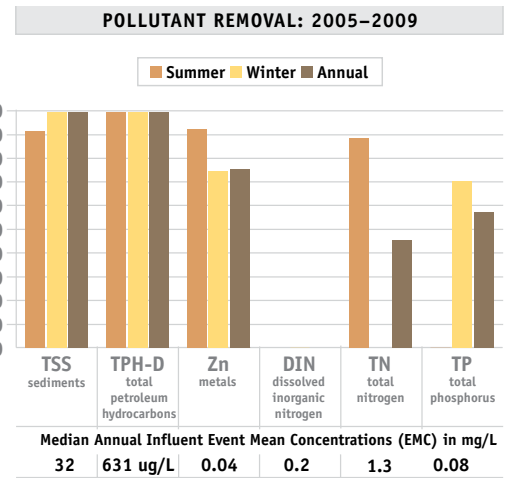

Pervious Concrete



Pervious concrete is a top performer with respect to water quality treatment and volume reduction, however care must be taken in areas where deicing chemicals will be used.

About Pervious Concrete

Pervious concrete (PC) is an effective approach to stormwater management in terms of both quantity and quality. Unlike retention ponds, PC systems do not require large amounts of additional space. The marginal cost between standard pavements and PC can be less than the associated drainage infrastructure (curb, catch basins, piping, and ponds) for standard impervious pavements. With PC systems, rainfall filters through the system and infiltrates back into the ground, which significantly reduces runoff volume, lowers peak flows, decreases temperatures, and improves water quality. In areas with sufficient sun exposure, PC can also speed snow and ice melt, reducing the salt required for winter maintenance. The PC design tested at UNHSC is distinctive in its use of coarse sand as a filter course - a refinement that enhances its filtration capacity improving water quality. With proper design, production, and installation, PC can be an excellent transportation structure and reasonable stormwater treatment system. As with most LID stormwater practices, PC is suitable for many sites. Typical usage includes parking lots, low-use roadways, sidewalks, and commercial developments with large areas of impervious surface. Care must be taken when locating PC or any infiltration system near pollution hotspots, or in areas of seasonal high groundwater. In such cases, the system can be

lined and outfitted with a subdrain that discharges to the surface or to storm sewers. The effectiveness of porous pavements has been demonstrated over a wide range of climates; however, impervious and pervious concrete can be damaged by the freeze thaw cycle and the use of deicing chemicals. To address this, it is essential that PC designs have an 16-20 % void space and a well-drained subbase. Proper curing of PC is needed to ensure a quality installation. Cure is required for structural load (7 days), to protect against freeze-thaw (28 days), and is needed prior to chloride deicing applications (12 months). Because of its permeability and high degree of reflectivity, PC can be challenging to maintain in the winter especially in areas that do not have good sun exposure. Where there is shading, snow and ice will accumulate increasing the need for salt application and plowing. As such, designs involving PC in cold climate regions should take shade cover into account. Clogging, poor installation practices, and complications from freezing temperatures will need to be considered when using PC in cold climate regions. Successful implementation of these systems relies on design, siting, proper mix production (including appropriate admixtures), construction oversight, maintenance, and proper cure times— all of which can be achieved with qualified suppliers and engineering oversight. As with other innovative technologies,

FAST FACTS	CATEGORY / BMP TYPE Pervious Pavement, Low Impact Development Design	Water Quality: Physical (Filtration) & Chemical (Sorption)	BASIC DIMENSIONS Surface Area: 21,000 sf	INSTALLATION COST \$4-5sf for materials and installation (does not include subbase)
	UNIT OPERATIONS & PROCESSES Hydrologic (Flow Alteration, Volume Reduction/Infiltration)	DESIGN SOURCE UNHSC & Northern New England Concrete Promotion Association (NNECPA)	SPECIFICATIONS Catchment Area: 21,000 sf Water Quality Volume: 1,750 cf	MAINTENANCE Maintenance Sensitivity: Low Inspections: 1-4 times per year Sediment Removal: High

Pervious Concrete Pavement in Cold Climates

Pervious concrete because of its deep subbase has been shown to be very resistant to freeze-thaw. Proper curing of PC is necessary to ensure quality installations and cold climate durability. There are 3 main curing requirements for PC: a 7 day cure for structural load, a 28 day cure to protect against freeze-thaw damage, and a 12 month cure prior to aggressive chloride deicing applications. The picture on the far right depicts delamination from chloride applications prior to the 12 month no-salt curing requirements. PC in adjacent parking areas where deicing salts were not applied appear structurally sound, open and intact.

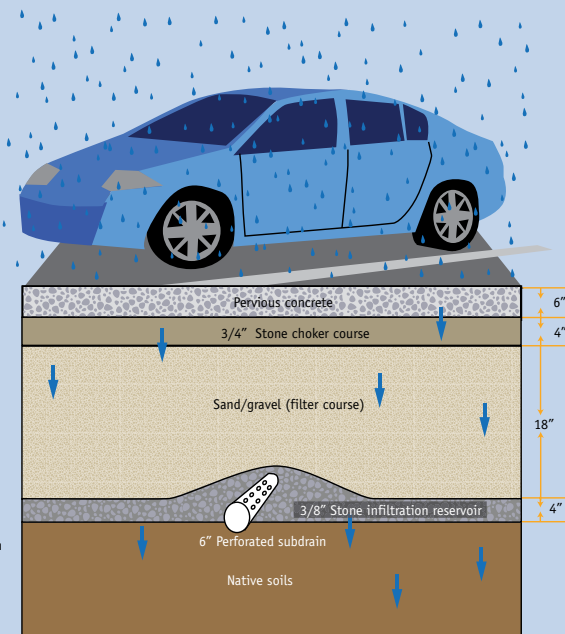

improvements in mix design coupled with added requirements for infiltration, and higher stormwater quality treatment standards make PC a reasonable stormwater management alternative in southern climates and in northern climates with additional consideration of proper curing requirements.

System Performance

Cost & Maintenance

Current estimates for pervious concrete materials and installation range from \$4 to \$5 per square foot. This does not include site work and subbase construction estimated at \$2 to \$4 per square foot, depending on depth of pavement. Routine maintenance has been performed since the PC lot was installed in 2007 as a matter of experimental design. Maintenance involves routine inspection and street vacuuming at least two times per year (spring and fall). Vacuum cleaning typically costs \$350-\$500 per acre per trip. Increased vacuuming frequency is expected for sites where runoff from adjacent areas flow onto the PC, where there are high traffic counts, and in areas where leaf fall and organic debris are excessive. The PC lot studied at UNH has undergone repairs for pavement degradation due to chloride application and insufficient cure time. Substantial raveling and pavement decay was observed in the drive lanes where chloride application was greatest. Areas protected from chloride observed no degradation.

Cold Climate

Winter performance of the PC system was observed to be exceptional for water quality, hydraulics, and infiltration capacity. Winter maintenance performance for deicing was mixed. Shaded areas of the PC lot had substantial challenges for deicing and required 20% additional chloride for deicing. Areas with good sun exposure required equal amounts of chloride as standard pavement. Throughout the winter, surface infiltration capacity averaged approximately 4,000 inches per hour with minimal seasonal change. Frost penetration was observed for depths of 15 inches in the pavement system. While the pavement froze sooner, deeper, and for longer periods than the reference condition, the pores remained open and well-drained year round, thus limiting freeze-thaw damage. When designed with a deep subbase and with proper installation and curing, the lifespan of these lots is expected to exceed standard pavements, which in northern climates tend to lose structural integrity after 12 to 15 years due to frost heaving. Sunnier parts of the UNHSC lot performed better than the nearby reference impervious asphalt pavement for traction and reduced snow and ice cover. In these areas, the formation of black ice resulting from melting and refreezing was essentially eliminated. However, in other parts of the lot, shading from adjacent tree cover increased winter maintenance load,

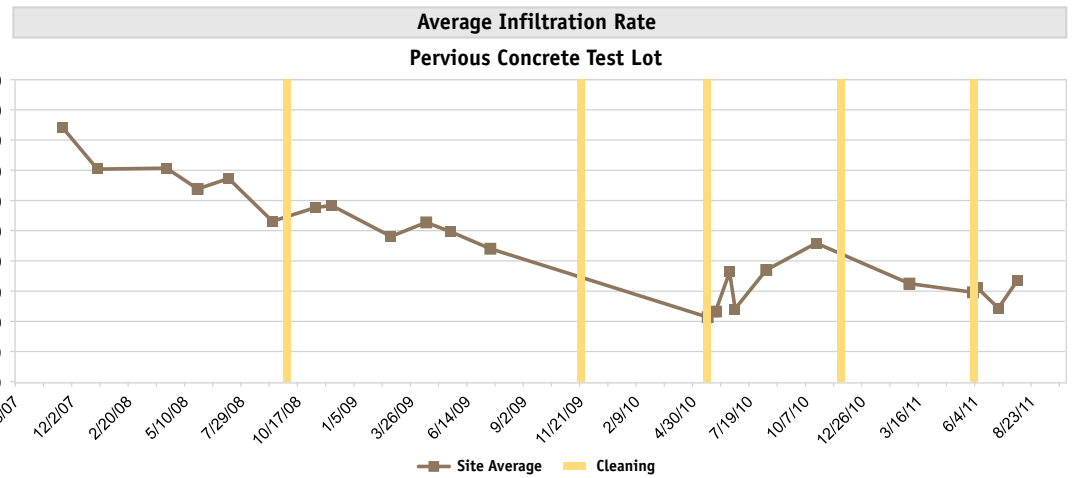

leading to reduced traction and a need for excess chloride for successful deicing. As with other porous pavements, PC deicing is more difficult during ice storms, or any time there is significant compacted snow and ice. The brine solution that collects on impervious surfaces instead infiltrates the porous pavement before it has a chance to melt ice effectively. The best approach in these circumstances is to apply excess deicing agents and to increase mechanical means of snow removal. A winter maintenance fact sheet is available online: www.unh.edu/unhsc.

Water Quality Treatment

Porous pavements can be expected to have substantial pollutant load reduction. The amount of load reduction is dependent on the degree of volume reduction and treatment efficiency. The water quality treatment performance of the PC system is similar to that of the PA system, which has been excellent and is consistently exceeding EPA's recommended treatment for most contaminants with the exception of nitrogen. The exceptionally high level of treatment is due in part to the use of a filter course in the subbase design. Systems with solely course aggregate layers have more of an infiltration and sedimentation function. The fine gradation of the filter course is for enhanced filtration and delayed discharge. Due to the high infiltration capacity of the underlying native soils, coupled with the system's capacity to store large volumes of water, a 95% runoff volume reduction has been observed since construction in 2007. The exceptional volume reduction limited the water quality assessment with only six storms that could be monitored throughout the monitoring period. The performance observed was similar to installations such as the porous asphalt lot. An interesting aspect of PC is its pH buffering of infiltrated water. Four years after its installation, the UNHSC PC lot infiltrated water demonstrates pH typically above 11. This could be an advantage in pH-challenged watersheds in need of buffering.

POLLUTANT REMOVAL: 2008-2010

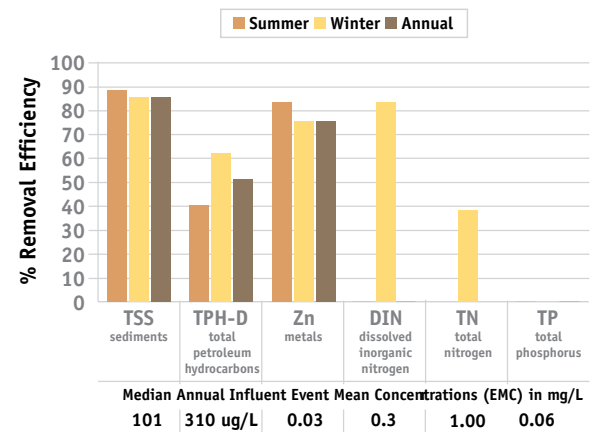

HYDRAULIC PERFORMANCE

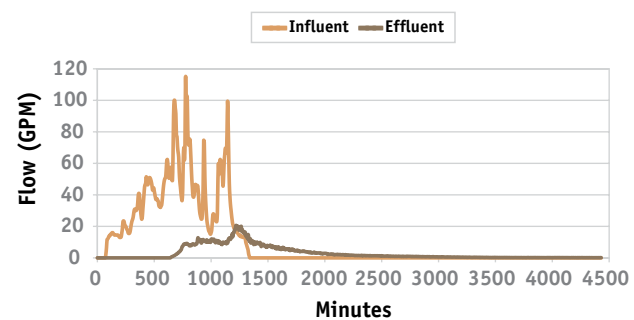

	Winter	Summer	Annual Average
Average Peak Flow Reduction	92%	96%	93%
Average Lag Time (minutes)	1,068	926	1,011
Average Volume Reduction	91%	98%	95%

Water Quantity Control

The pervious concrete system's ability to manage runoff was exceptional, with 95% volume reduction on an HSG-B soil. An infiltration reservoir and elevated underdrains were designed to infiltrate the water quality volume. No surface runoff has been observed from this lot since its installation in 2007. This replaced a preexisting asphalt lot that created a local problem of severe surface erosion and gully. Significant groundwater recharge has been achieved—far in excess of predevelopment conditions.

Permeable Interlocking Concrete Pavement



PICP is a high durability and logical choice for effective stormwater management. PICP provides remarkable runoff volume reductions while providing an enhanced aesthetic appeal.

About Permeable Interlocking Concrete Pavement

Permeable Interlocking Concrete Pavements (PICP) are a pervious pavement system comprised of precast paving units. Similar to other permeable pavements, storm water storage and treatment occur in the constructed subsurface. The UNH installation retrofitted Hood House drive located on the main campus in the summer of 2010. A standard Interlocking Concrete Pavement Institute (ICPI) profile was used for the drive lane and a modified section with an internal storage reservoir was used in the parking area. Applications of this technology often include parking areas, driveways, sidewalks, and other low speed driving areas. Permeable pavements have been shown to be active over a wide range of climates. Proper design for cold climate prevents damage from freeze-thaw cycle. PICP can be visually stunning and add a strong architectural flair to pavement while at the same time providing tremendous water quality and hydrologic benefits.

System Performance

Cost & Maintenance

The 2010 installation cost of the PICP lot which includes pavers, jointing and bedding materials and mechanical installation was approximately

\$4 per square foot. Paving units would have an added expense associated with hand installation if necessary. Individual units typically must be cut and placed along the edge of any nonuniform shape.

The permeability of PICP exists between the paving units themselves. The units have a small gap that is filled with chip stone. Maintenance is performed by cleaning with a regenerative air vacuum. One of the most important elements of maintenance of PICP is a design to minimize run-on. A low maintenance design is the best way to minimize clogging. Other clogging mechanisms include sediment tracking from vehicles, and organic litter buildup between the paving units. Attempts to clean the PICP surface have yielded variable results. Regenerative air vacuums work well to pick up bulk surface debris, but their effectiveness at removing deeper debris from between the pavers is still being researched. A strong vacuum can also result in the removal of the joint stone between the units. Preventative maintenance is essential in preserving high permeability for heavily used areas. This includes routine removal of surface debris through vacuuming or with the use of leaf blowers at a minimum of twice per year. One substantive benefit of PICP over other porous pavements is that they can be completely regenerated. If a system is clogged, a high-

FAST FACTS	CATEGORY / BMP TYPE Porous Pavement	Biological (Vegetative & Chemical (Sorptions))	Water Quality Flow: 1 cfs Water Quality Volume: 542 cf	Maintenance Sensitivity: Low Inspections: Low Sediment Removal: High
	UNIT OPERATIONS & PROCESSES Hydrologic (Flow Alteration) Water Quality: Physical (Sedimentation, Filtration),	BASIC DIMENSIONS 6,500 sf	INSTALLATION COST \$4.00 per sf mechanically installed	
		DESIGN SOURCE: UNHSC AND ICPI Catchment Area: 0.15 acre		
			MAINTENANCE	

How the System Works

1. Rainfall infiltrates into the paver joints that are filled with clean aggregate (ASTM No. 8 stone) into the bedding course (ASTM No. 8).
2. Stormwater drains through the bedding course, through the open-graded base (ASTM No. 57 stone), and into the stone subbase reservoir (ASTM No.2 stone). Through these layers the physical process of filtration provides treatment of the stormwater runoff.
3. Installed in the stone subbase are perforated underdrains placed 4 inches above the native soils which provides retention and infiltration. Internal check dams constructed of an impermeable liner are installed for every 12" drop of elevation to provide storage on a sloped grade.
4. Excess water flows through the elevated underdrains to the municipal storm sewers or receiving water.

WATER QUALITY TREATMENT PROCESS

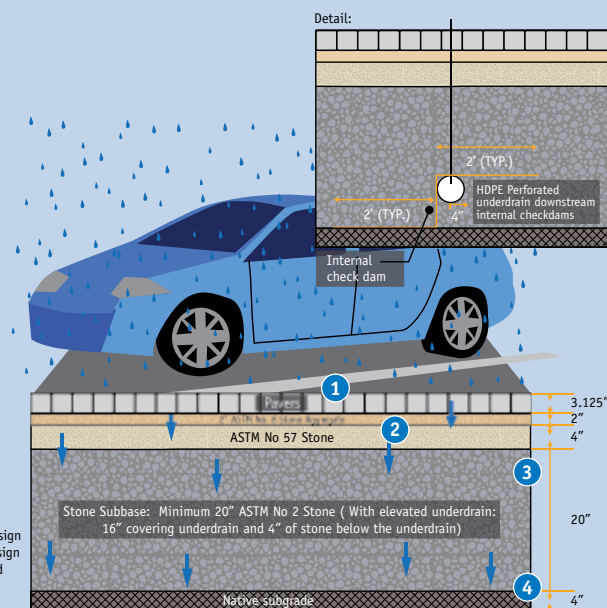

Please note: This design includes subbase design for cold climates and drainage for low permeability soils.

There is an internal check dam which consists of non-woven geo textile covering the upstream side of the 4" diameter perforated underdrain as shown in the detail in the top right.

strength vacuum could be used to remove the joint stone and clogging debris, and the stone would then be replaced along with hydraulic capacity.

Cold Climate

With proper design and installation, the PICP system is a suitable stormwater management system for cold climate regions. The well-drained subbase and capillary barrier limits freeze thaw and reduces damage to the system by winter plowing. Conventional winter maintenance by salt and plowing is effective at removing the majority of snow and ice from the surface. Surface infiltration minimizes black ice formation thereby reducing the salt required for winter maintenance.

Water Quality Treatment

The water quality treatment performance of the PICP system has been excellent. Mass load reduction and removal efficiencies exceed 99% for pollutants due to a tremendous amount of infiltration. Effluent volumes are typically 99% less than the influent volume. The figure and table to the middle right reflect the system's performance in achieving runoff volume reductions and subsequent pollutant mass load reductions. Values represent results recorded over the study period.

Water Quantity Control

The PICP system has performed exceptionally well for stormwater volume reduction. Rainfall drains directly through the joints between the interlocking pavers and infiltrates into the subgrade. This significantly reduces peak flows, decreases runoff temperatures, and reduces runoff volumes. The PICP system is built over HSG-C soils and shallow depth to bedrock. Underdrains are installed 4 inches above the native soil to promote infiltration. It is rare that a storm event generates any effluent in the underdrains.

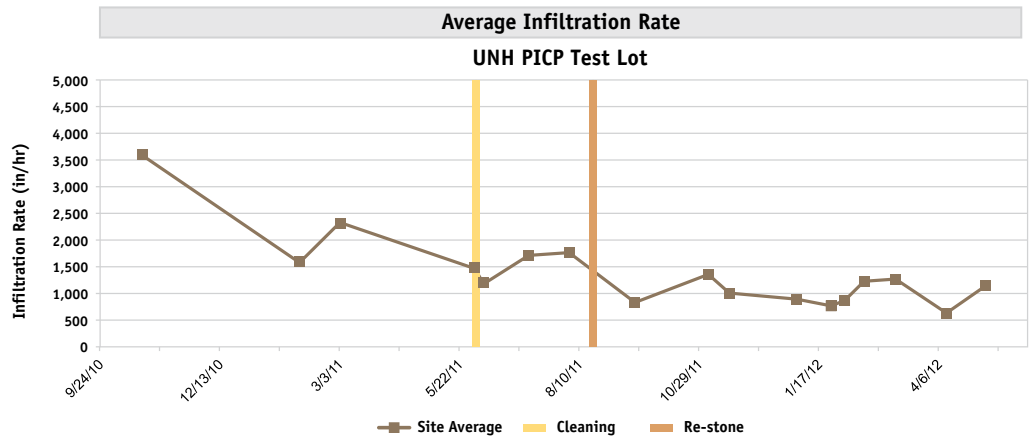

WATER QUANTITY			
Date	Total Influent Volume (gal)	Total Effluent Volume (gal)	% Volume Reduction
n	26	26	26
Average	2586	1.18	99.93%
Median	2045	0.75	99.97%
Standard Deviation	2145	1.41	0.00
Coefficient of Variation	0.83	1.20	0.00

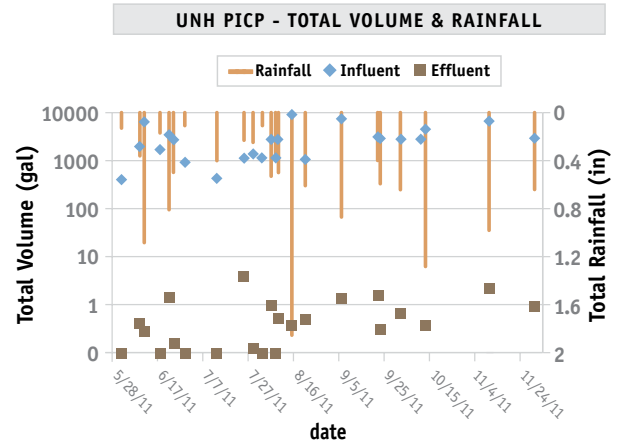

SYSTEM DESIGN ▼

The PICP lot is designed to handle the WQV and CPV. The design consists of four basic layers:

Top layer: Paving units are placed on top, are 3.13 inches high by 4 inches wide by 8 inches long with a 0.25 inch gap filled with ASTM No. 8 stone with ~13% surface void space for infiltration; pavers are laterally contained by granite curbing or concrete headers.

Second layer: Two inches of an open-graded bedding course of No. 8 stone supports the pavers;

Third layer: Four inches of an open-graded base course of ASTM No. 57 stone to support the bedding course, and provide filtration;

Fourth layer: Seventeen to twenty inches of an open-graded reservoir subbase of ASTM No. 2 stone is installed over native materials as a capillary barrier to minimize frost heaving. Perforated underdrains are installed in the reservoir 4 inches above the native materials and provides storage and infiltration. The sides of the system may be lined with geotextile fabric to prevent migration of fines; a bottom lining is only recommended with poor structural soils or when infiltration is not desired. Geotextiles in horizontal layers should be used with caution as they can lead to premature clogging.

Subsurface Gravel Wetland



Subsurface Gravel Wetland systems continue to offer superior treatment for common stormwater pollutants and unparalleled treatment of nutrients.

About the Subsurface Gravel Wetland

The subsurface gravel wetland has been around for almost 15 years but enjoyed little implementation until the UNHSC pioneering studies. It approximates the look and function of a natural wetland, effectively removing sediments and other pollutants commonly found in runoff while enhancing the visual appeal of the landscape by adding buffers or greenscape to urban areas. The subsurface gravel wetland evaluated at UNHSC for 8 years is a horizontal-flow filtration system and should not be confused with stormwater wetlands that function more like ponds. Instead, the subsurface gravel wetland includes a dense root mat, crushed stone, and an anaerobic microbe rich environment for improving water quality. Like other filtration systems, it demonstrates a tremendous capacity to reduce peak flow and improve water quality. By design, the subsurface gravel wetland by itself is not intended for infiltration of stormwater.

Implementation

Subsurface gravel wetlands can be used in many regions, with the exception of those that are too arid to support a wetland system. These systems have demonstrated exceptional water

quality treatment, in particular for nutrients, for a range of land uses including commuter parking, high density commercial use, and major transportation corridors. Subsurface gravel wetland systems can be space intensive but can be easily retro-fitted into dry ponds. Like any system that relies on infiltration or filtration, subsurface gravel wetland systems should be lined and outfitted with subdrains that discharge to the surface if they are to be used in pollution hotspots. Dissolved oxygen levels may fluctuate within biologically active subsurface systems like the subsurface gravel wetland, yet if this is a problem for local receiving waters, then it can easily be dealt with by introducing turbulence and aeration into the outlet design. While subsurface gravel wetlands are more expensive than other LID systems, they represent a dramatic performance improvement over ponds. Subsurface gravel wetlands are especially effective at removing nitrogen and have been used for some time in wastewater treatment.

Application

Subsurface gravel wetlands use is increasing, especially in areas where impaired waters exist or where higher standards are necessary. The State of New Jersey has provided loans and grants for subsurface gravel wetland

FAST FACTS	CATEGORY / BMP TYPE Stormwater Wetland, Low Impact Development Design	Water Quality: Physical (Sedimentation, Filtration), Biological (Vegetative Uptake, Microbial Mediation), & Chemical (Sorption)	Forebay Footprint: 10 ft long X 32 ft wide Total Area: 5,450 sf	INSTALLATION COST \$22,500 per acre treated
	UNIT OPERATIONS & PROCESSES Hydrologic (Flow Alteration)	BASIC DIMENSIONS Filter Basin Footprint: 15 ft long X 32 ft wide	SPECIFICATIONS Catchment Area: 1 acre Water Quality Flow: 1 cfs Water Quality Volume: 3,300 cf	MAINTENANCE Maintenance Sensitivity: Medium Inspections: 1-4 times per year Sediment Removal: High

How the System Works

WATER QUALITY TREATMENT PROCESS ▼

1. Runoff flows into a pretreatment forebay to remove settleables and gross solids.
2. Runoff exits the forebay through two stacked horizontal pipes (primary and secondary spillways). The lower pipe is a 6 inch pipe with a 1 inch orifice and the top pipe is a 12 inch pipe and into the treatment cells.
3. Hydraulic riser inlets conduct water to the subsurface gravel layer. There, biological treatment occurs through the uptake of pollutants by vegetation and anaerobic microbial activity within the gravel and soil. Physical and chemical treatment—the trapping of contaminants—occurs on and within the gravel filter media and root mat. Other UOPs

include sedimentation, transformation through reduction/oxidation, and sorption with organic matter and mineral complexes.

4. Treated runoff exits to the surface via an outlet pipe that includes an orifice control elevated four inches below the wetland surface. This insures that the soil is nearly continuously saturated—a condition that promotes vegetation growth and denitrification.

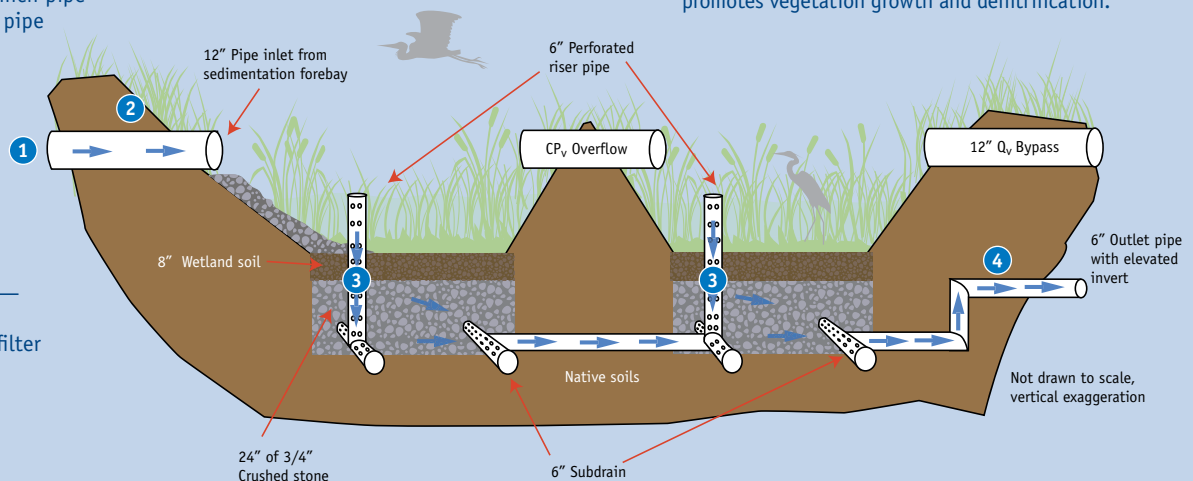

installations. In addition the New Hampshire Department of Transportation employs them at park and rides. These systems work well in retrofit applications such as the Berry Brook project in Dover, NH.

System Performance

Cost & Maintenance

Subsurface gravel wetland installation cost was \$22,500 per impervious acre. Removal of system biomass (vegetation) should occur at least once every three growing seasons. The dense vegetation has been observed to have little problems with invasive plants. Maintenance activities include the removal of accumulated sediment biomass in the forebay and treatment cells. Research has demonstrated the value of biomass removal for long-term nutrient uptake. Without this practice, nitrogen rerelease will begin to occur. Maintenance is critical to ensure that influent (runoff) can remain well-aerated before it enters the denitrifying environment of the subsurface. Forebay maintenance of vegetation prevents the reintroduction of pollutants, particularly nitrogen and phosphorus and reduces maintenance on the treatment cells.

Cold Climate

The subsurface gravel wetland's water quality treatment and water quantity control capacity remained strong in all seasons. The gravel wetland's primary flow path is subsurface and enters the system through perforated riser pipes such that freezing of the wetland surface does not impact routing. Nitrate removal declines during the winter season while removal of other pollutants remained high in cold climates.

Water Quality Treatment

The subsurface gravel wetland does an exceptional job of removing nearly all of the pollutants commonly associated with stormwater treatment performance assessments. Subsurface gravel wetlands consistently exceed EPA's recommended level of removal for total suspended solids and meets regional ambient water quality criteria for nutrients, heavy metals, and petroleum hydrocarbons. The chart at the middle right reflects the subsurface gravel wetland's performance in removing total suspended solids, total petroleum hydrocarbons, zinc, dissolved inorganic nitrogen, total nitrogen, and total phosphorus. Values represent results recorded over 8 years, with the data further divided into summer and winter components. Additional sites are being monitored for long-term performance including high-use commercial uses. Of particular importance for coldwater fisheries, the mean July temperature of runoff leaving the system was 66.0 degrees F—12 degrees lower than the retention pond.

Water Quantity Control

Like other filtration systems, the subsurface gravel wetland exhibits tremendous capacity to reduce peak flows ~87%. The figure above illustrates effective peak flow reduction and long lag times for the range of seasons monitored.

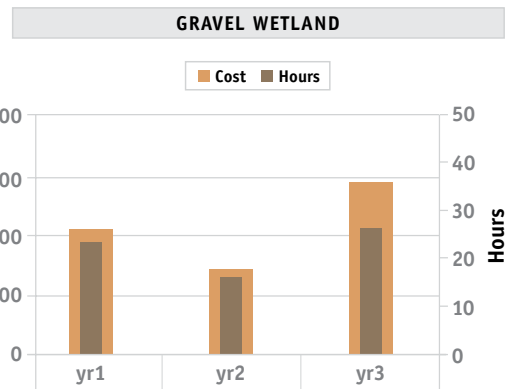
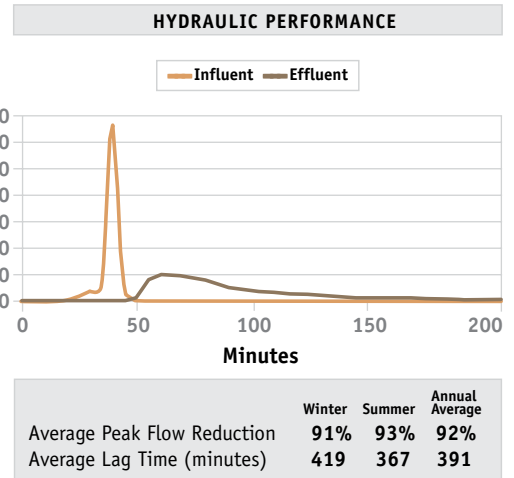
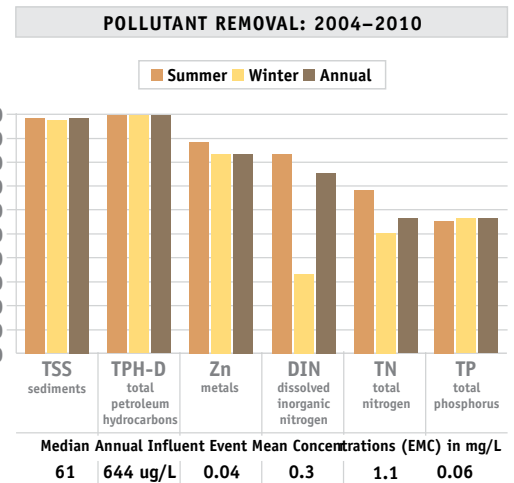

SYSTEM DESIGN ▼

This subsurface gravel wetland was designed by UNHSC. Its rectangular footprint occupies 5,450 square feet and can accommodate runoff from up to one acre of impervious surface. It includes a pretreatment forebay, followed by two flow-through treatment basins. (Other pretreatment approaches may be used.) Each treatment basin is lined and topped with two feet of gravel and 8 inches of wetland soil. The system is designed to retain and filter the water quality volume (WQv) 10 percent in the forebay and 45 percent above each treatment cell. It can detain a channel protection volume (CPv), and release it over 24 to 48 hours. The conveyance protection volume (Q10) is bypassed. For small, frequent storms, each treatment basin filters 100 percent of the influent it receives. For larger storms that do not exceed the design volume, some stormwater bypasses the first treatment basin and is only processed by the second. When storms exceed the design volume, the first inch of rain (first flush) is treated, while the excess is routed to conveyance structures or receiving waters. The treatment cells host a diverse mix of native wetland grasses, reeds, herbaceous plants, and shrubs.

Bioretention Systems



Bioretention systems are the workhorse of LID approaches and offer flexible, adaptive and reliable treatment of stormwater runoff.

About Bioretention Systems

Bioretention systems, also known as “rain gardens,” are among the most common Low Impact Development (LID) stormwater approaches in use today. These systems consist of landscaped depressions which collect runoff that subsequently ponds, filters through a soil mix, and infiltrates into the ground, or discharges to the surface. The UNHSC has evaluated many different bioretention systems; this report specifically examines four bioretention designs (Bio 1, Bio 2, Bio 3, and Bio 4), two of which are new, and two of which have been studied and reported on previously. While structural variations exist, the main differences between these systems relate to the composition of bioretention soil mix (BSM) – namely sand, compost, wood chips, and loam.

Implementation

Bioretention systems are used throughout all areas of the U.S., but their acceptance and implementation varies regionally. An increasing number of states are requiring higher levels of water quality treatment and volume reduction that only can be achieved through the incorporation of filtration and infiltration designs like bioretention systems. In some regions, local acceptance is hindered by lack of performance data, unfamiliarity with the design, concerns over maintenance, and suspicions in regards to seasonal functionality. To maximize volume reduction of stormwater runoff with bioretention systems, they should be located in soils that accommodate infiltration, such as those classified as hydrologic soils group “A” (sand, loamy sand, or sandy loam with high infiltration rates) and group “B” (silt loam or loam with moderate infiltration rates).

System Performance

Cost

The installation costs associated with the bioretention systems implemented by UNHSC ranged from \$14,000 to \$25,000 per acre of impervious cover “IC” treated. These costs will moderate as installers and designers gain familiarity with the systems. In 2007, UNHSC installed Bio 4 in a vegetated parking lot median strip as a retrofit at a total cost of \$14,000 per acre, including \$8,500 per acre for labor and installation, and \$5,500 per acre for materials and plantings. These findings indicate that for municipalities with equipment and personnel, the retrofit costs are nearly \$5,500 per acre of drainage. These costs do not include design, permitting, or construction supervision costs.

Maintenance

Bioretention systems are designed for minimal maintenance. As indicated by the graph in the bottom right, the highest maintenance burden occurs during the first two years of operation as the vegetation grows and the system begins to stabilize. Once vegetation is established, maintenance decreases and becomes very predictable, similar to what is required for standard landscaping. Common maintenance tasks include seasonal mowing, raking, and pruning of vegetation. Beyond two years, long-term maintenance tends to level off and involve more routine and schedulable maintenance activities. The average of all maintenance costs and personnel hours required for the bioretention systems studied at UNHSC were \$1,820 and 21 hours of labor per year per acre of IC treated, respectively.

Infiltration rates (IR) are easily measured in bioretention systems using standard methods (ASTM D3385 – 09) or even more simply with instruments like the Turf-Tec Infiltrometer. At the UNHSC, IR was measured for all bioretention-

Issues in Focus

BIORETENTION SOIL MIX COMPOSITION ▼

System	Date Installed	Soil Mix				Vegetation Cover	Hydraulic Loading Ratio Drainage Area : Filter Area	PSD		
		Sand	Compost	Soil	Woodchips			Date	Organic Content	% passing 200 um sieve
Bio-1	2004	45%	10%	45%	0%	Trees and Wetland Plants	18:1	2004	4.2	2%
Bio-2	2005	60%	10%	10%	20%	Wooded Vegetation	160:1	2005	2.9	7%
Bio-3	2009	60%	10%	10%	20%	Eco-Lawn	160:1	2009	6.6	10%
Bio-4	2008	70%	30%	0%	0%	Prairie Meadow Perennial	32:1	2008	9.9	8%

The soil mix used in the bioretention systems is central for determining flow control and water quality treatment performance. Hydraulic conductivity of bioretention soil mixes is variable and usually trends toward higher infiltration rates than originally designed for. Infiltration rates of BSM mixes are strongly correlated to the percent that passes the 200 sieve and guidance largely suggests that the fines should ideally be between 2-5%. Current research shows variable nitrogen and phosphorus removals and that additional research is needed to optimize bioretention systems for nutrient treatment.

tion systems studied. The figure below compares IR over the range of bioretention systems. Of particular interest is the decline of IR over time for 3 out of the 4 bioretention systems. This can be predicted and is likely due to the accumulation of fine materials on the surface of the filter. The IR reduction rate can be used to schedule cleanings and maintenance of the filter.

In contrast to the other systems vegetated with native perennial plants, the Bio 3 system was different in that the basin was vegetated with a conservation mix often used for detention basins), and contained a continuous dense vegetative cover. Previous studies have indicated that plant roots generally experience a 30% die back each year which aids in the development of macropores that keep soil surface IC high over time. The data from this study seems to suggest that dense vegetative cover is more important than plant type for maintaining IR in vegetative systems. If aesthetics are not a concern, then it is conceivable that grassed bioretention systems could reduce overall maintenance burdens in bioretention systems.

Cold Climate

The ability for bioretention systems to treat water quality and control water quantity remained relatively consistent in all seasons over the range of systems monitored. UNHSC researchers have observed that most LID stormwater systems, when properly designed and installed, are not negatively impacted by cold climate.

Water Quality Treatment

All bioretention systems have proven effective at removing sediment-bound pollutants commonly associated with stormwater treatment performance assessments. Additionally, the systems consistently exceed EPA's recom-

mended level of removal for total suspended solids and achieved requisite removal for petroleum hydrocarbons and metals (TZn). However, the performance for nutrients is more variable. With the exception of Bio 2, the range of systems consistently removed dissolved inorganic nitrogen (DIN). A consistent trend with respect to percent removals was apparent in that a definite seasonality and a virtual ceiling at 40 – 45% removal were observed. Exceptions include Bio 2 which had no real DIN removal. This may be due to a less dense root mat and a reduced filter area caused by shading and pedestalling from woody vegetation. Over time woody vegetation can crowd and shade out bioretention areas and may not be suitable for this application. Total Phosphorus (TP) treatment performance was variable but trended toward efficiencies of roughly 20-30%, and may be maximized by limiting phosphorus levels in the design BSM. The chart at the right reflects bioretention performance in removing total suspended solids, total petroleum hydrocarbons, total zinc, dissolved inorganic nitrogen, total nitrogen, and total phosphorus.

WATER QUANTITY CONTROL			
Systems	Winter	Summer	Average
Bioretention 1			
Average Peak Flow Reduction	77%	74%	75%
Average Lag Time (minutes)	408	108	266
Bioretention 2			
Average Peak Flow Reduction	74%	85%	79%
Average Lag Time (minutes)	346	265	309
Bioretention 3			
Average Peak Flow Reduction	84%	85%	84%
Average Lag Time (minutes)	215	217	216
Bioretention 4			
Average Peak Flow Reduction	94%	95%	95%
Average Lag Time (minutes)	52	67	61

BIORETENTION PERFORMANCE

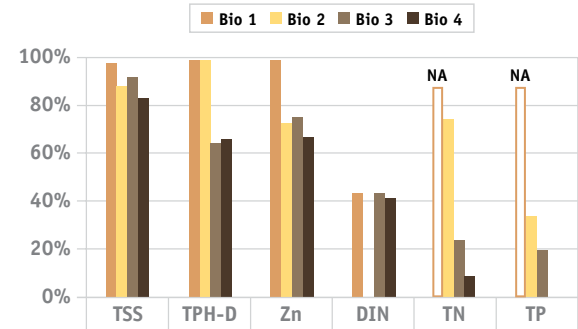

BIORETENTION

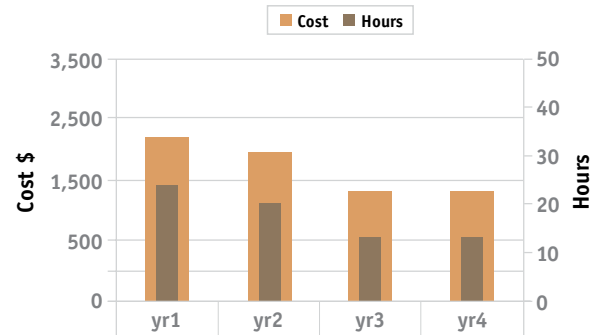

BSM INFILTRATION RATES

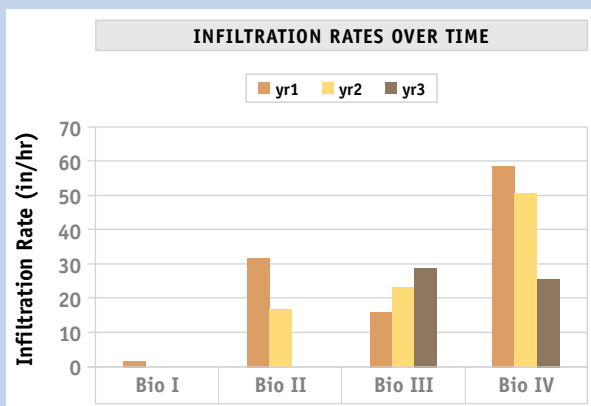

The accepted optimum infiltration rate for bioretention soil mixes ranges between 0.5 to 12 inches per hour. Sandy bioretention soil mixes should provide excellent water quality performance with respect to most sediment associated pollutants. Designs with safety factors >3 should consider orifice control in bioretention underdrains in N and P sensitive watersheds. UNHSC research indicates that more robust vegetative cover is higher in importance as compared to plant selection or placement in maintaining long term surface infiltration rates.

Tree Box Filter



Tree box filters are ideal for stormwater management retrofits. Tree box filters are based on the same principles as bioretention systems but offer high flow-rate capacity and reliable treatment for most common stormwater pollutants.

About the Tree Box Filter

Tree filters are mini bioretention systems that combine urban landscaping and drainage. Tree filters are available both as proprietary and non-proprietary systems, the difference being the level of design and ease required for use. Proprietary systems are ready off the shelf. Non-proprietary systems are inexpensive and require design of all critical components and use commonly available parts. They are typically located behind a curb and sidewalk and used to replace catch basins to treat relatively small drainage areas (<10,000 sf). Urban foresters support their usage as one way to improve the longevity of urban trees which are commonly starved of nutrients and water. One advantage of street trees over typical bioretention in highly urbanized areas is the decreased need for routine aesthetic maintenance to remove trash and debris. Because they are often deep and covered with a grate, the accumulation of trash and debris on the filter surface is not visible as it is in a surface bioretention system. In urban environments the need to clean systems can be frequent. Their water quality treatment performance is high, similar to other high-capacity bioretention systems. The first tree filter at UNH was installed in 2004. Results of monitoring both proprietary and non-proprietary system are presented here.

Implementation

Tree filters are highly adaptable and can be used in many development and LID retrofit scenarios. They are especially useful in settings where minimal space is available. In urban areas, tree filters can be used in the design of an integrated street landscape - a choice that transforms isolated street trees into stormwater filtration devices. Tree filters can be installed in open-bottomed chambers in locations where infiltration is desirable, or in closed-bottomed chambers where infiltration is either impossible (clay soils) or undesirable (high groundwater or highly contaminated areas). Lateral openings may be included in the treebox for areas where root growth is acceptable. In these instances, tree filters may be used in combination with structural cells to provide soil and space for tree root growth under sidewalks or pavements. In general, tree filters are sized and spaced much like catch basin inlets, and design variations are abundant. Common catch basin drainage areas may range from 3,000 to as large as 30,000 square feet of impervious area. The system evaluated at UNHSC was designed by researchers to treat 5,000 square feet. Other proprietary designs are also increasingly available and can provide additional pretreatment.

FAST FACTS	CATEGORY / BMP TYPE Filtration, urban retrofit, LID, manufactured treatment device.	DESIGN SOURCE UNHSC, Filtterra	acre Filtterra Design: 0.3 acre	(\$30,000/acre treated) Filtterra Design: Not reported
	UNIT OPERATIONS & PROCESSES Water Quality: Physical (Filtration) Biological (Vegetative uptake) Chemical (Sorption)	BASIC DIMENSIONS UNHSC Design Diameter: 6 ft Depth: 4 ft Filtterra Design: Varies	Water Quality Volume: UNHSC Design: 425 cf Filtterra Design: Not reported	MAINTENANCE Maintenance Sensitivity: Medium Inspections: 1-4 times per year
		SPECIFICATIONS Catchment Area: UNHSC Design: 0.1	INSTALLATION COST UNHSC Design: \$3,000 for materials, \$3,000 installation	Sediment Removal: High

Issues in Focus

TREE BOX FILTER SOIL COMPOSITION ▼

System	Date Installed	Soil Mix				Vegetation Cover	Organic Content	% Passing 200µm Sieve	Structural	Hydraulic Loading Ratio
		Sand	Compost	Soil	Woodchips					Drainage Area : Filter Area
UNHSC Tree Filter	2005	80%	20%	-	-	Green Ash	2.1	5%	None	156:1
Portsmouth Tree Filter	2011	Not disclosed				Red Maple	2.9	2%	None	311:1

System Performance

Cost & Maintenance

The cost to install a tree filter to replace a single catch basin is about \$6,000 per system. Labor and installation costs are approximately \$3,000, and materials and plantings an additional \$3,000. For municipalities with equipment and personnel, the cost for retrofits can be relatively low. Proprietary tree filters are becoming increasingly popular, can be as much as \$20,000, and offer the advantage of a complete design package that is easily incorporated into a development or retrofit project. Treatment efficiencies for nutrients are low, as hydraulic loading rates and infiltration capacity are high. Since the installation of the UNHSC system in 2004 there has been minimal maintenance. Aside from routine trash and leaf removal, the highest maintenance burden is associated with periodic inspection to assure that the bypass and soils are adequately conveying water. Clogging typically occurs in the top two inches of surface soil making servicing of these systems simple. Long-term maintenance may involve periodic removal (vacuuming) or raking of surface fines similar to that of deep sump catch basins. The system at the UNHSC was maintained in 2008 by removal of the top two inches of surface accumulation. Maintenance was initiated after a noticeable reduction in infiltration and increased incidence of bypass following parking lot sealcoating. An accumulation of sealcoat fines caused a noticeable infiltration reduction. This raised the concern that the coincidence of filter systems and sealcoating may be problematic long-term.

Tree replacement depends upon the hardiness of the selected species and the aggressiveness of the root growth. Tree filter maintenance should be consistent with the marginal costs associated with bioretention systems.

Cold Climate

The tree filter's ability to treat water quality remained relatively stable in all seasons. This is consistent with UNHSC observations of most LID stormwater systems—when they are properly designed and installed, they are not dramatically impacted by seasonal fluctuations. While some seasonal variation in infiltration capacity and nitrogen removal does occur, cold conditions do not seem to warrant significant design alterations.

Water Quality Treatment

The tree filter is effective for removing many pollutants and consistently exceeded EPA's recommended level of removal for total suspended solids, and also meets regional ambient water quality criteria for petroleum products and total zinc. The treatment effectiveness appears to be reduced for nitrogen due to the high infiltration capacity of the tree filters which regularly exceed 120 in/hr. The chart at top right reflects system performance in removing total suspended solids, total petroleum hydrocarbons, total zinc, dissolved inorganic nitrogen, total nitrogen, and total phosphorus. Values represent results recorded over six years for the UNHSC system and one year for a proprietary system installed in Portsmouth, NH.

Water Quantity Control

Tree filters do little to reduce peak flows unless they are installed in sandy soils with moderate to high infiltration rates. The tree filter displays no significant peak flow reduction or lag time for the range of seasons monitored.

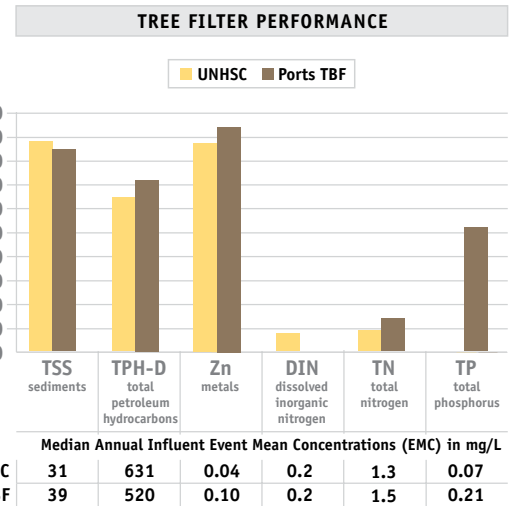

SOIL INFILTRATION RATES ▼

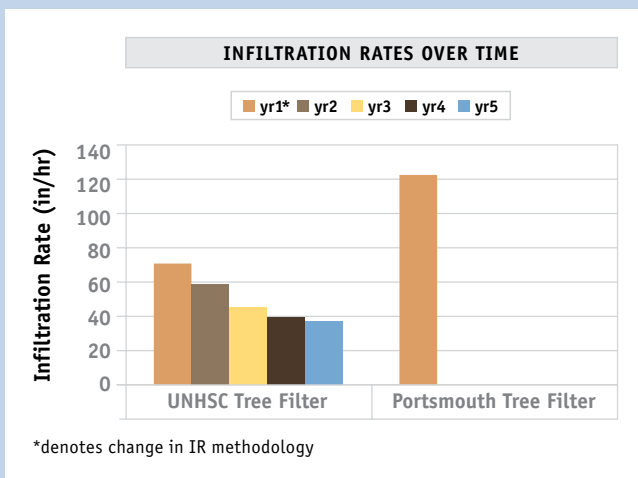

Detention Ponds



Detention ponds can be effective for many common stormwater pollutants but efforts to reduce operation and maintenance costs should be considered during system design.

About Detention Ponds (A.K.A. Dry Ponds / Dry Detention Basins)

Detention basins or dry ponds are common stormwater management systems widely used for water quantity control. Detention basins are designed to store large volumes of water and regulate effluent flow by providing flood control, peak flow reduction, and some stormwater treatment. Compared to retention ponds which maintain a permanent pool of water, detention basins are designed to fully drain within 24-48 hrs of a storm event. Unique to the UNHSC detention pond design was a covered gravel outlet to improve water quality. A key design feature includes the 24 to 48 hour retention time for the water quality volume regulated by an orifice control at the outlet control structure. This increased residence time for a smaller storm event promotes additional pollutant removal through sedimentation, vegetative uptake, and some pollutant transformation by microbial activity. Ponds were shown to excessively heat runoff in the summer and overly cool runoff in the winter, which can be of concern to cold water fisheries. A well maintained and mature detention basin can provide habitat and aesthetic benefits in urban settings.

Implementation

Dry detention ponds are one of the most widely implemented stormwater best management practices (BMP) used today. They can be designed for any region or climate, but may be difficult to locate in ultra-urban settings or adjacent to sensitive ecosystems. A dry pond tends to have a large footprint, making them difficult to fit into compact development designs. Areas that have highly polluted runoff may need a more extensive treatment system or treatment train to protect water quality. Dry ponds are ideal in locations where flood control and peak flow reductions are the primary objectives for runoff management. Dry ponds can be installed in most soil types and geology.

System Performance

Cost & Maintenance

The cost to install the UNHSC detention pond system for treating runoff from one acre of impervious surface was \$13,700 (2004 dollars). Maintenance activities involve routine inspection, periodic mowing, and sediment removal. The perception that ponds require minimal maintenance contributes to their popularity. However, the detention pond studied required the third highest annual maintenance costs of the UNHSC studied

FAST FACTS	CATEGORY / BMP TYPE	DESIGN SOURCE	SPECIFICATIONS	MAINTENANCE
	Dry Pond UNIT OPERATIONS & PROCESSES Hydrologic (Flow Alteration) Water Quality: Physical (Sedimentation) & Biological (Vegetative Uptake)	New York State Stormwater Management Design Manual BASIC DIMENSIONS 46 ft X 70 ft	Catchment Area: 1 acre Water Quality Flow: 1 cfs INSTALLATION COST \$13,500 per acre treated	Maintenance Sensitivity: High Inspections: 1-4 times per year Sediment Removal: Medium/High

Detention Pond vs. Retention Pond

The primary difference between detention ponds and retention ponds is a permanent pool of water. Detention ponds are designed to fully drain within 6 to 24 hours depending on total storm depth. UNHSC conducted and published performance evaluations of retention ponds in the 2007 and 2009 biennial reports. The two systems are similar in their capacity to manage peak flows and large storm volumes. The two systems also have modest capacity for removing nutrients. In regards to sediments (TSS), petroleum hydrocarbons (TPH-D), and metals (TZn), the systems begin to demonstrate unique treatment patterns. As shown in the figure to the right, the retention pond is consistent throughout the year in its ability to remove TSS and TPH-D while the detention pond has a higher efficiency for treatment during the summer months. This is likely due to the retention pond permanent pool of water providing consistent treatment for settling sediments throughout the year. The detention pond has shown to have higher removals for TSS but lower annual removals of TPH-D. The seasonal treatment pattern for TZn is the same for each system with higher removals during summer months. The retention pond developed a thick layer of floating vegetation that may have contributed to the removal of TZn. Removal of TZn in the detention basin is likely due to the association of metals to sediments.

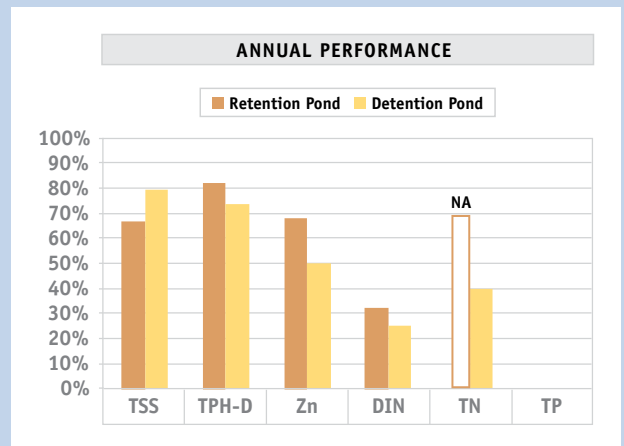

systems with \$2,400 and 24 total hours per acre of treatment. While little maintenance may be required to support the ability for a detention pond to manage peak flow and large volumes, more frequent attention is critical to maintain effective water quality treatment performance. Allowing the plants to die back in the winter and decompose within the system has proven to re-release nutrients in the pond outflow. Annual removal by mowing of vegetation is critical to its long-term effectiveness for water quality treatment.

Cold Climate

Detention pond performance is not greatly affected during cold weather months. Water quality performance for sediments and metals does not vary substantially. Some reductions in nutrient removal have been observed seasonally. Water quantity management is unaffected during the winter months and no alterations to system design for cold weather have been made.

Water Quality Treatment

Median TSS removal efficiencies for the detention pond studied at UNHSC fall just below EPA's recommended criteria of 80% removal of suspended sediments. With regular maintenance, the system can provide long-term removal of solids and trash, and moderate removal of petroleum hydrocarbons, metals, and nutrients. Pollutants associated with sediments (petroleum hydrocarbons, metals) are readily removed through sedimentation whereas soluble pollutants (nitrate) pass through the system with minimal reduction. This particular system was installed with a covered gravel outlet, a simple improvement that increased removal of suspended sediments through coarse filtration. Reduction in petroleum hydrocarbons are likely associated

with sediment removal. Removal of nutrients are moderate as the detention time is sufficient for some vegetative uptake and microbial degradation to occur.

Water Quantity Treatment

Detention basins are very effective for storing large volumes of water. The system tested is designed to store runoff from a one-inch storm (WQv) and release it slowly over a 24 - 48 hour period through a hydraulic control structure. Storm depths that exceed design capacity are bypassed to an adjacent vegetated swale. This design has proven an effective approach for flood control and peak flow reductions. During summer months temperatures of detained water can be significantly increased, second only to retention ponds. Detention ponds, or dry ponds, are excellent opportunities for WQ retrofit. Most ponds are designed for flood control or peak flow reductions for a 10 year desing storm or greater. For the water quality performance demonstrated here, the system would need to be retrofitted with an additional flow control for the 1 inch WQv. Dry ponds with sufficient space, can be easily retrofitted to include sub-sections of gravel wetlands or bioretention systems.

SYSTEM DESIGN ▼

The performance of the detention basin is not greatly affected during cold weather months. Water quality performance for sediments and metals does not vary substantially. Some reductions in nutrient removal have been observed seasonally. Water quantity management is unaffected during the winter months and no alterations to system design for cold weather were necessary.

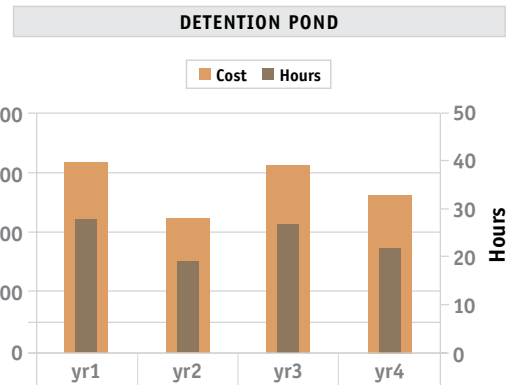
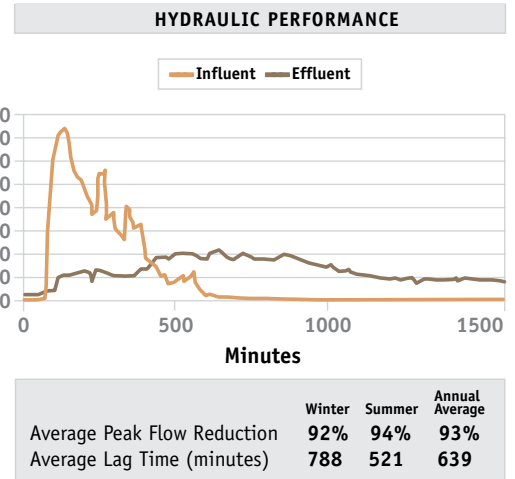
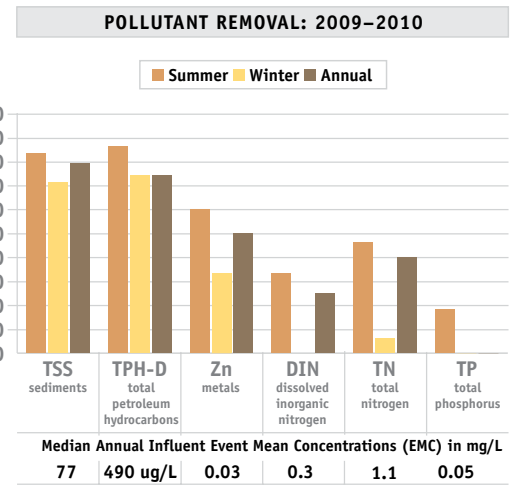

Offline Hydrodynamic Separators



Offline configurations dramatically increase BMP performance with respect to sediment removal because the highest flows bypass the system and therefore do not flush-out sediment trapped in previous storms.

About Offline Hydrodynamic Separators

Hydrodynamic separators (HDS) are small, flow-through devices that can be easily designed or retrofitted into ultra-urban and space-constrained projects. Primary treatment is through enhanced particle sedimentation and removal of floating debris. A substantial concern of online HDS systems is the resuspension of solids from high flows. The offline configuration tested includes a flow diversion structure upstream of the HDS unit designed to bypass flows exceeding the water quality flow. This configuration prevents high flows from entering the system and resuspending sediments captured in the HDS chamber. The offline configuration proved to be extremely effective at increasing the system performance for removing solids and petroleum hydrocarbons. The offline configuration of the HDS was an inexpensive design improvement which more than doubled the overall system performance. An offline HDS could be used as a pretreatment measure in combination with a filtration system to create a more effective treatment train system.

Implementation

The approved use of HDS devices varies from state to state. This variability is due, in part, to concern of resuspension and low performance in field tests. Some states approve the use of HDS devices for primary stormwater treatment while others limit their use to pretreatment. Some states now require the offline usage of HDS. Many states require field performance certification before HDS systems can be used for primary treatment.

System Design

The selection of HDS devices is in accordance with local watershed conditions and target water quality treatment objectives. Often, these systems are designed to replace or retrofit existing catchbasins. The offline configuration consists of a typical HDS device with an upstream flow diversion structure. The HDS unit is configured for tangential flow, meaning that stormwater enters the device through an off-center inlet that creates a swirling hydrodynamic action to enhance particle settling. The system outlet is typically located behind a baffle to remove floating debris, oil, and grease. The offline configuration bypasses high flows around the HDS chamber. Treated and bypass flows are comingled downstream of the HDS chamber.

FAST FACTS	CATEGORY / BMP TYPE Sedimentation, Conventional Design	BASIC DIMENSIONS Diameter: 6 ft Depth: 6 ft Sump: 4 ft	Water Quality Volume: 1,100 cf	MAINTENANCE Maintenance Sensitivity: Low Inspections: annually depending on loading Sediment Removal: Low
	UNIT OPERATIONS & PROCESSES Water Quality: Physical (Sedimentation)	SPECIFICATIONS Catchment Area: 0.3 acre Water Quality Flow: 0.33 cfs	UPSTREAM FLOW DIVERTER INSTALLATION COST \$1,500 per unit for materials, \$1,500 for installation	
	DESIGN SOURCE Manufacturer			

How the System Works

1. Runoff flows into the flow diversion structure upstream of the HDS unit. Design flows pass directly through to the HDS while higher flows are conveyed around the structure through a bypass channel.
2. Design flows enter along the perimeter of the HDS unit such that the direction and velocity of the flow creates a hydrodynamic separation within the center of the system that causes sediments to fall out of suspension and settle to the bottom of the chamber.
3. Flow exits the system under a baffle which traps floatables within the HDS unit.
4. Treated effluent and untreated bypass flow combine downstream of the unit and are conveyed to receiving waters.

WATER QUALITY TREATMENT PROCESS

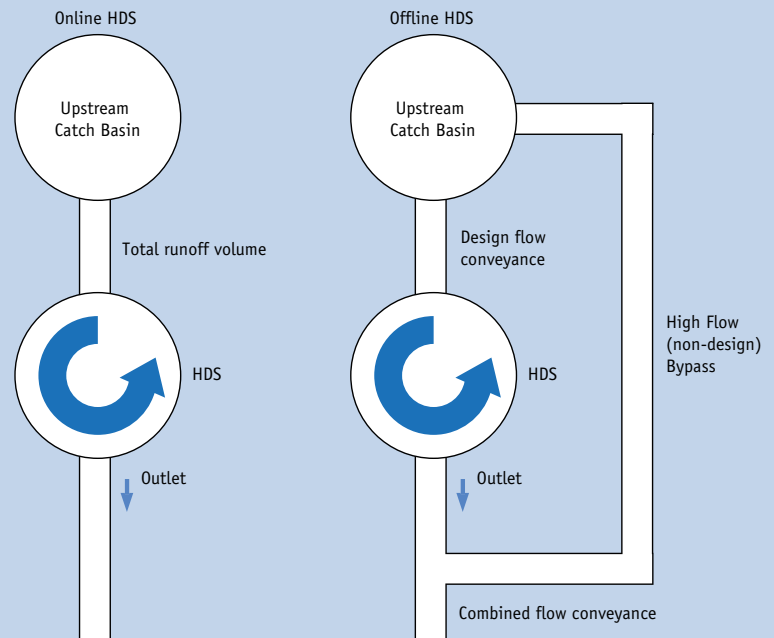

System Performance

Cost and Maintenance

The installation cost of HDS devices range from \$18,000 to \$20,000 per acre of runoff treated, plus \$3,000 for the upstream flow diversion materials and installation. Maintenance consists of quarterly inspections to determine sediment accumulation within the HDS chamber. From the inspections a maintenance schedule is developed for debris removal by a vacuum truck; frequency depends on sediment loading.

Cold Climate

Suspended sediment removal is significantly affected by colder temperatures. Particle settling velocities are much slower in colder saline waters and therefore the performance of an HDS unit is greatly reduced. The median removal of sediments drops by 36% from summer to winter months. There is no difference in water conveyance from summer to winter.

Water Quality Treatment

The Offline HDS configuration performed well for removal of suspended sediments and petroleum hydrocarbons. A comparison of the same HDS device installed in both an online and offline configuration demonstrated an annual TSS removal efficiency of 21% for the online configuration and 75% for the offline configuration. During summer months the offline configuration achieved 86% removal of total suspended solids compared to a 30% removal efficiency for the online configuration. Removals are lower during the winter due to decreased particle settling velocities in colder, chloride laden runoff. The device also met regional ambient water quality criteria for removal of petroleum hydrocarbons. However, removal of heavy metals was low and nonexistent for nutrients.

Water Quantity Control

Typically, HDS devices are flow-through systems. Therefore, they exhibit little to no peak flow reduction, volume detention, or lag time.

HDS PERFORMANCE ONLINE VS. OFFLINE

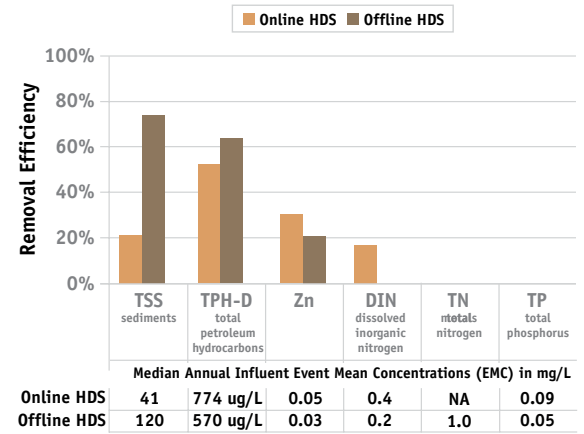

SYSTEM DESIGN ▼

Traditionally, the design of stormwater drainage systems has been focused on the collection and conveyance of stormwater runoff offsite as rapidly and as efficiently as possible. In contrast, LID drainage designs focus on conforming as much as possible to natural drainage patterns and discharging to natural drainage paths or landscape features within the watershed. Catch basins and stormwater drainage networks are efficient flow conveyance structures, yet when water quality treatment and runoff volume reduction are the goals of a stormwater management plan, this may not be an advantage. Where possible, runoff should be allowed to flow across pervious surfaces or through grass channels and buffers. When it is necessary to install an HDS treatment system or design for a curb and gutter drainage network, using an offline configuration is the most effective for coarse solids removal. Online configurations are the most common designs and consist of HDS devices or catch basins installed in series conveying water from multiple inlets. A comparison of the two design strategies are shown in the figures to the left.

Maintenance

A Comparison of Maintenance Cost, Labor Demands, and System Performance

The maintenance perceptions of Low Impact Development (LID) systems represents a significant barrier to the acceptance of LID technologies. Despite the increasing use of LID, stormwater managers still have minimal documentation in regards to the frequency, intensity, and costs associated with LID operations and maintenance. Due to increasing requirements for more effective treatment of runoff and the proliferation of total maximum daily load (TMDL) requirements, there is greater need for more documented maintenance information for planning and implementation of stormwater management strategies.

Marginal Costs

Marginal costs for maintenance activities associated with total suspended solids (TSS), total phosphorus, and total nitrogen (TN) removal were converted to an annual cost per system, per watershed area treated, per mass of pollutant removed – \$/acre/lb/yr. Because TN removal efficiencies were not available for every BMP tested, dissolved inorganic nitrogen (NO₃, NO₂, NH₄) was instead used. Capital costs for BMPs are presented in terms of per acre of IC treated (2004 dollars), and maintenance expenditures are presented as an annualized percentage of capital costs, a measure routinely used for projected BMP cost estimates.

The figures included in each of the BMP sections illustrate costs associated with maintenance over the years of study per acre of IC treated. Some systems such as the retention pond and the subsurface gravel wetland displayed cycling maintenance costs over the course of the study, while others, such as the bioretention and porous pavement systems, reached equilibrium after the first few years of operation. Annualized data are summarized. In the majority of cases, costs and personnel hours for LID systems were lower in terms of per mass of pollutant removed as compared to conventional systems. While the vegetated swale is the least costly system in terms of maintenance, it is also the least effective in terms of annual pollutant load reductions. This data indicates that marginal costs and marginal pollutant load reductions for LID systems are easier and less costly to maintain but still achieve greater pollutant load reductions. Exceptions occur with respect to any LID or conventional BMP that does not incorporate unit operations and processes that effectively target nutrients.

Sand filter maintenance burdens can be regulated by reducing the watershed area to filter area ratio. However, in cases where costs per mass of pollutant trend toward unrealistic levels, alternative systems or treatment train approaches should be adopted as primary water quality management measures.

Maintenance as a Percent of Capital Cost

Maintenance costs are a substantial portion of the life-cycle costs of stormwater management practices. Estimates can vary and there may be economies of scale for larger systems. As illustrated in the table to the right, annual maintenance expenses as a percentage of capital costs ranged from 5% - 23%. Amortized maintenance costs for the retention pond equaled total capital construction costs after only 4.5 years of operation. LID systems, with the exception of the sand filter, had higher capital costs but lower annual maintenance costs as compared to the conventional retention pond and detention pond systems. As shown in Table 3, the lowest LID treatment system annualized maintenance costs expressed as a percentage of capital costs were porous asphalt (5%) followed by bioretention (9%) and the subsurface gravel wetland (10%). At these costs, amortized annual LID system maintenance expenditures will equal total upfront capital costs after 11 years for bioretention and the subsurface gravel wetland system, and after 20 years for the porous asphalt system.

Conclusions

Many communities are struggling to define stormwater BMP maintenance needs in the absence of clear documentation. As a step towards providing this information, maintenance activities and costs for a range of stormwater management strategies were calculated. Marginal costs, maintenance frequency, level of effort required, complexity, and pollutant load reductions were all factors that were considered.

The results of this study indicate that generally, LID systems, as compared to conventional systems, have lower marginal maintenance burdens (as measured by cost and personnel hours) and higher water quality treatment capabilities as a function of pollutant removal performance. Although LID system maintenance will be different and may require additional training, it should not require unusual burdens for management.

UNHSC researchers harvest vegetation in the forebay of the subsurface gravel wetland system. It is important that forebay treatment areas of wetland systems remain aerobic for reliable nitrogen reductions.



BMP MAINTENANCE/ACRE/YR BY CATEGORY

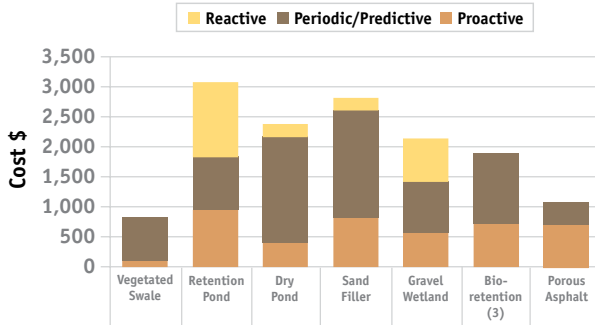

BMP MAINTENANCE PERSONNEL HOURS/ACRE TREATED/YEAR

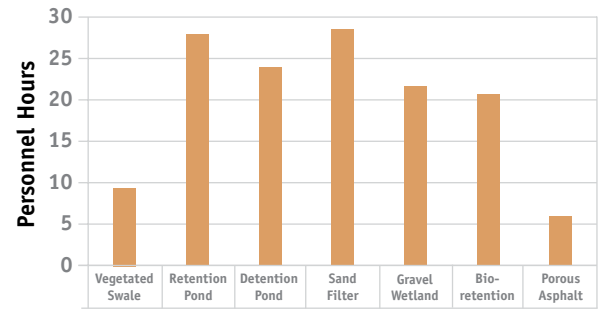

Summary of maintenance costs, capital costs and cost comparison per lb removed of TSS, TP and TN as DIN

	RE	Annual lbs Removed	Annual Ave Maintenance (\$ per Acre)	Maintenance (Cost/yr/acre/lb)	Capital Cost (2012 dollars)	O&M as a %CC
TSS						
Vegetated Swale	58%	360	\$820	\$2	\$14,600	6%
Retention Pond	68%	420	\$3,060	\$7	\$16,500	19%
Detention Pond	79%	480	\$2,380	\$5	\$16,500	17%
Sand Filter	51%	310	\$2,810	\$9	\$15,200	19%
Gravel Wetland	96%	590	\$2,140	\$4	\$27,400	8%
Bioretention (3)	92%	560	\$1,900	\$3	\$25,600	8%
Porous Asphalt	99%	610	\$1,080	\$2	\$26,600	5%
TP						
Vegetated Swale	0%	NT	\$820	NT	\$14,600	6%
Retention Pond	0%	NT	\$3,060	NT	\$16,500	19%
Detention Pond	0%	NT	\$2,380	NT	\$16,500	17%
Sand Filter	33%	0.9	\$2,810	\$3,240	\$15,200	19%
Gravel Wetland	58%	1.5	\$2,140	\$1,400	\$27,400	8%
Bioretention	27%	0.7	\$1,900	\$2,670	\$25,600	8%
Porous Asphalt	60%	1.6	\$1,080	\$690	\$26,600	5%
TN						
Vegetated Swale	0%	NT	\$820	NT	\$14,600	6%
Retention Pond	33%	7.8	\$3,060	\$390	\$16,500	19%
Detention Pond	25%	5.9	\$2,380	\$400	\$16,500	17%
Sand Filter	0%	NT	\$2,810	NT	\$15,200	19%
Gravel Wetland	75%	18	\$2,140	\$120	\$27,400	8%
Bioretention	29%	7.9	\$1,890	\$280	\$25,600	8%
Porous Asphalt	0%	NT	\$1,080	NT	\$26,600	5%

NT = No Treatment

Targeted Research

The University of New Hampshire Stormwater Center conducts targeted research into a range of topics, including: how best to overcome the social and economic barriers that inhibit effective stormwater management; how to help decision makers understand the implications of their choices on the greater ecosystem; and how to advance the field of stormwater science so that it can address these needs effectively. In this section, we'll report on three such projects: the economic benefits of LID practices, porous pavement system hydrology, and polycyclic aromatic hydrocarbon (PAH) pollution from coal-tar-based sealants.

The Economic Benefits of LID Practices

In 2011, UNHSC released Forging the link, a report which included case studies detailing the cost benefits of LID for commercial, residential, and municipal settings. The first two case studies show how utilizing an LID approach for site drainage engineering, specifically with porous asphalt and bioretention systems, can lead to more cost-effective site and stormwater management designs with better water quality treatment.

Residential Development (Boulder Hills)

In 2009, a residential development was constructed consisting of a 14-acre, 24-unit condominium community in Pelham, New Hampshire. The initial conventional design proposal had substantial wetland impacts, asphalt paving, and typical drainage (curbing, catch-basins, stormwater ponds, outlet structures). A second design was proposed that used widespread infiltration and filtration on the site's extensive upland sandy soils, and included rooftop infiltration trenches, porous asphalt driveways, sidewalks, and New Hampshire's first porous asphalt

road. The LID option had a 6 % reduction in site development expenses (\$49,000 less) as compared to the conventional option. Although materials for the porous asphalt itself were more expensive, overall cost reductions were achieved due to reductions in drainage infrastructure, site clearing, and erosion control. In addition, the LID design provided more open space on the site.

Parking Lot Bioretention Retrofit

A bioretention retrofit was performed at the University of New Hampshire campus. In certain instances using existing resources, simple retrofits can be performed at minimal expense. This retrofit involved the installation of a bioretention system within the vegetated median in the parking lot and subsequently connecting the system directly to adjacent drainage infrastructure. Facilities operations can often provide both labor and equipment for retrofitting existing infrastructure. In this instance, and many others with municipal staff, retrofit expenses were limited to design and materials costs only, while installation expenses for labor, equipment, and some infrastructure can be potentially avoided. Total project cost per acre of impervious cover was \$14,000. With labor and install provided, costs were limited to materials and plantings at \$5,500 per acre of impervious cover.

Conventional CSO Abatement

Conventional storage, pumping, and treatment are extremely effective, yet resource intensive for both construction and long-term operations. The Narragansett Bay Commission (NBC) in Providence, Rhode Island, under EPA direction, initiated a phased CSO Abatement Plan for mitigating CSOs and protecting the Narragansett Bay and the region's urban rivers. Phase I of the project included a \$365 million, three-mile, 30-foot diameter deep rock tunnel with an estimated 62 million gallons of capacity for reducing overflow volumes by approximately 40 percent. The associated operational and maintenance costs of Phase I are one million dollars per every one billion gallons of stormwater and sewage flow, or one dollar for every 1000 gallons (Brueckner, 2009). Phase II of the CSO abatement plan includes two near-surface interceptors for conveying flow at an estimated capital costs of \$250 million.



Final rolling of a new porous asphalt roadway installation in a residential subdivision in NH.

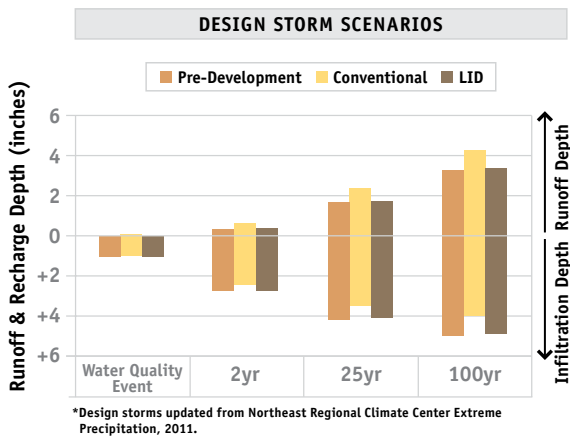

The commercial development at Greenland Meadows, NH employed porous asphalt, internal water storage, and a subsurface gravel wetland to manage stormwater that flowed into a 303D-listed stream. Not only does effluent water exceed water quality targets, LID realized an almost one million dollar savings over conventional stormwater management.

Comparison of Unit Costs for Materials for Greenland Meadows Commercial Development			
Item	Conventional Option	Low Impact Development Option	Cost Difference
MOBILIZATION / DEMOLITION	\$555,500	\$555,500	\$0
SITE PREPARATION	\$167,000	\$167,000	\$0
SEDIMENT / EROSION CONTROL	\$378,000	\$378,000	\$0
EARTHWORK	\$2,174,500	\$2,103,500	(\$71,000)
PAVING	\$1,843,500	\$2,727,500	\$884,000
STORMWATER MANAGEMENT	\$2,751,800	\$1,008,800	(\$1,743,000)
ADDITIONAL WORK-RELATED ACTIVITY (utilities, lighting, water & sanitary sewer service, fencing, landscaping, etc.)	\$2,720,000	\$2,720,000	\$0
PROJECT TOTAL	\$10,590,300	\$9,660,300	(\$930,000)

* Costs are engineering estimates and do not represent actual contractor bids

Permeable Pavement System Hydrology

Although permeable pavement system hydrology is complex, it can be viewed in a black box framework in which rainfall is translated into a runoff hydrograph. In such a framework, monitored precipitation and runoff hydrographs are inverted in order to calibrate runoff characteristics. For this study, a porous asphalt system was monitored over a four-year period from 2005-2008 in Durham, NH. The system includes porous asphalt at the surface with layers of stone, filter, stone, and native soil. In the bottom stone layer are perforated subdrains to collect water that percolated through the overlying layers and ponded on the native soil to the elevation of the subdrain inverts. It is the flow from these subdrains that yield the runoff hydrographs for the porous asphalt system. The NRCS curve number (CN) method was then employed whereby a CN was calculated for runoff events with rainfall excess of 2.3 cm (0.9 in). This CN calibration occurred in five methods. In one method, CN is computed from total and excess precipitation (Method 1: Q-P method). In the next three methods, CN is computed from time measurements (lag time, time base, time of concentration). In the last method, the graphical peak discharge method is inverted to compute CN.

Results were in line with expectations. When computing CN from total precipitation and excess precipitation, the “yield” is calculated. In this case, over a high permeability soil, the CN will be low, but where there is low permeability native soil and/or high groundwater such as the UNHSC site, CN will be high reflecting high yield. For this study, the median CN for Method 1 was 96, as the site is at an HSG C soil and groundwater is seasonally at the elevation of the subdrains. However, for all other methods the CN is in the single digits owing to the fact that there is significant hydrograph attenuation. This attenuation stems from the fact that in the porous asphalt system, the filter-layer - which is predominantly in an unsaturated state even during large storms - throttles the flow to the subdrains below.

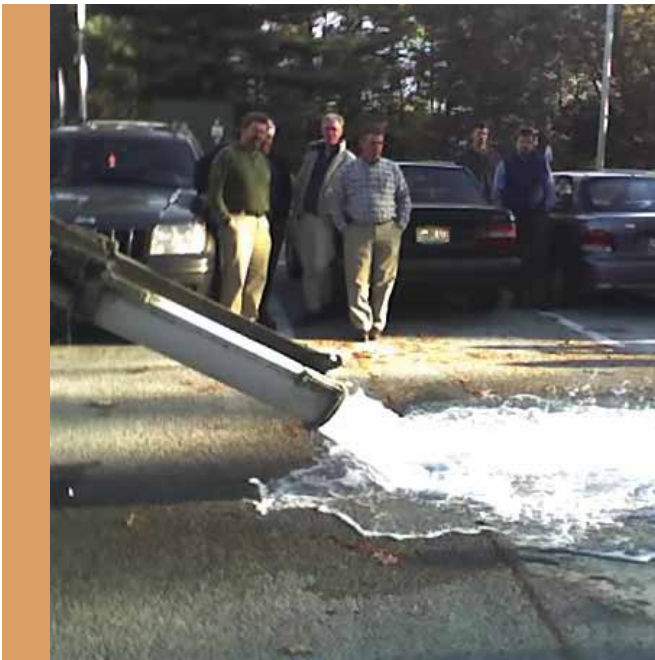

Initial surface inundation testing of the pervious concrete parking lot at the UNHSC.

Curve Number Statistics For Observed Storms					
	Method 1 Q-P	Method 2 t_l	Method 3 t_p	Method 4 t_c	Method 5 q_p
Max	100	41	68	68	110
Min	63	1	0	0	0
Mean	92	10	7	8	8
Median	96	6	3	4	2
sd	9.7	9.3	11.0	10.6	19.6
n=45, hydrologic soil type=C, good condition, curve number=70					

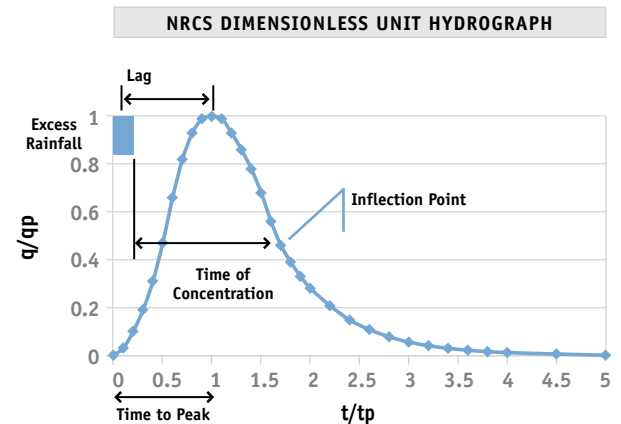

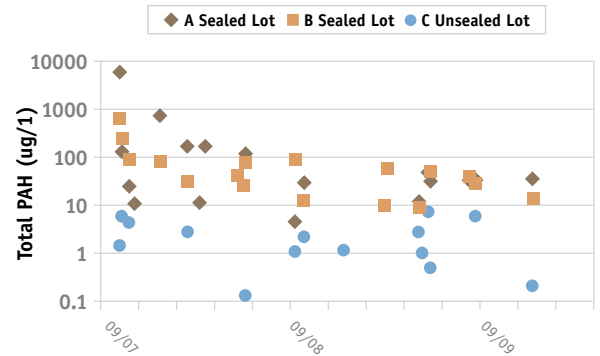
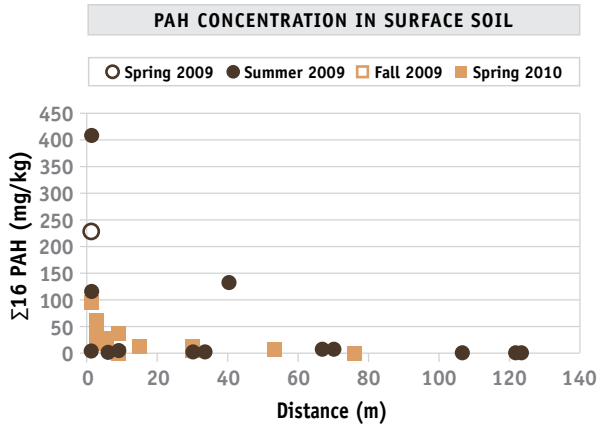

Coal-Tar-Based Sealcoat vs Asphalt

Sealcoat, a thin, black coating applied over asphalt pavements that is marketed as improving appearance and enhancing pavement longevity, is made of either an asphalt emulsion or a refined coal-tar pitch emulsion. Although the two sealcoats are similar in appearance and cost, concentrations of polycyclic aromatic hydrocarbons (PAHs), a group of organic compounds known to be detrimental to human and ecosystem health, are about 1000 times higher in coal-tar-based sealcoats than those based in asphalt.

In 2007, UNHSC applied coal-tar-based sealcoat to two parking lot areas, then measured the PAH concentrations in stormwater runoff, stormwater treatment sediments, and surface soil adjacent to the parking lots.

This study found that PAH concentrations in runoff from the sealed surfaces were significantly higher than in runoff from an adjacent unsealed lot. Concentrations decreased over the two-year stormwater sampling period, but remained elevated relative to the unsealed lot. PAH concentrations in sediments collected in stormwater treatment devices receiving runoff from the sealed lots were two orders of magnitude higher than sediments from the unsealed lot, and remained high in 2011, four years after the sealant was applied. Surface soil adjacent to the sealed lots also contained high concentrations of PAHs. Benzo(a)pyrene, a carcinogenic PAH, was present at concentrations of up to 29 parts per million, which far exceeds the EPA industrial screening level for benzo(a)pyrene of 0.21 parts per million.

(Left) The UNHSC has an informational flyer about pavement sealcoat.

(Right) Measured PAH concentrations in UNHSC filter systems after the sealcoat experiment.

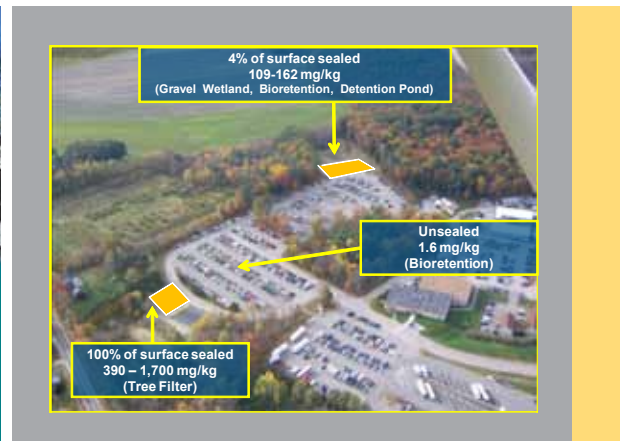
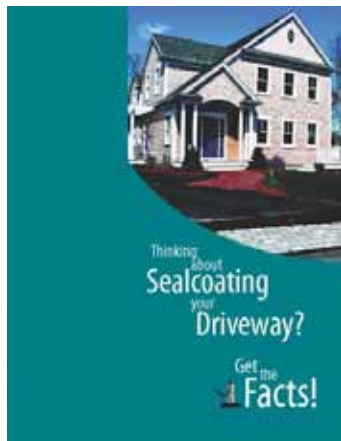

Administration

UNHSC Faculty & Staff

Thomas P. Ballestero, PE, Ph.D., PH, CGWP, PG
Director
603.862.1405
tom.ballestero@unh.edu

James J. Houle, CPSWQ
Program Manager and
Outreach Coordinator
603.862.1445
james.houle@unh.edu

Alison Watts, Ph.D.
Research Professor
of Civil Engineering
603.862.0585
alison.watts@unh.edu

Timothy A. Puls, EIT
Research Project Engineer I
Field Facility Manager
603.343.6672
timothy.puls@unh.edu

Robert M. Roseen, PE, Ph.D.
Former director 2004 - 2012

Graduate Students

UNHSC is indebted to the hard work of the following graduate students, past and present:

Present Students

Iulia Barbu
Research Assistant
& Doctoral Candidate,
Civil Engineering
iaj4@unh.edu

Viktor Hlas
Research Assistant
in Civil Engineering,
Masters Candidate
603.862.1172
vir3@wildcats.unh.edu

Ann Scholz
Research Assistant
in Civil Engineering,
Masters Candidate
603.862.1172
amj387@cisunix.unh.edu

Robin M. Stone
Research Assistant
in Civil Engineering,
Masters Candidate
603.862.1172
rml54@wildcats.unh.edu

Former Students

Pedro M. Avellaneda
Research Assistant,
Doctoral Recipient,
Civil Engineering

Joshua F. Briggs
Research Assistant,
Masters Recipient,
Civil Engineering

Nicholas P. DiGennaro
Research Assistant,
Masters Recipient,
Civil Engineering

George Fowler
Research Assistant,
Masters Recipient,
Civil Engineering

Kristopher Houle
Research Assistant,
Masters Recipient,
Civil Engineering

Julie Maimes
Research Assistant,
Masters Student,
Natural Resources

Angie Miles,
Research Assistant,
Masters Recipient,
Civil Engineering

Robert Wildey
Research Assistant,
Masters Recipient,
Civil Engineering

Undergraduate Students

UNHSC supports the University's commitment to undergraduate participation in research. The following UNH undergraduates have been involved in UNHSC research:

Jay Anastasiades
Sarah Bajor
Joel Ballestero
Kyle Bastien
Nate Bradley
Trevor Branch
Darlene Brown
Heather Gilbert
Ethan Giles
Angela Gong
Eric Hadley
John Heaney
Jack Jackson
Eliot Jones
Matt Shump
Greg Sine
Pat Sullivan
Georgian Tutuianu
Federico Uribe
Kent Walker
Allison Wasiewski
Megan Wengrove

UNHSC Dedicated to the protection of water resources through effective stormwater management.



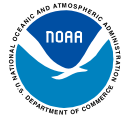
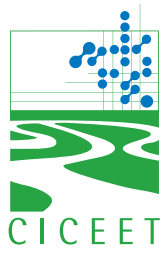

UNIVERSITY
of NEW HAMPSHIRE

This publication was produced by the UNH Stormwater Center in partnership with the UNH/NOAA Cooperative Institute for Coastal and Estuarine Environmental Technology. It was printed on recycled paper.



University of New Hampshire
Stormwater Center

Gregg Hall, 35 Colovos Road
University of New Hampshire
Durham, NH 03824
www.unh.edu/unhsc

DEVELOPMENT OF UNSATURATED FLOW FUNCTIONS FOR LOW IMPACT
DEVELOPMENT STORMWATER MANAGEMENT SYSTEMS FILTER
MEDIA AND FLOW ROUTINES FOR HYDROLOGICAL
MODELING OF PERMEABLE PAVEMENT SYSTEMS

BY

IULIA AURELIA BARBU

B.S., Technical University of Civil Engineering Bucharest, 2005

DISSERTATION

Submitted to the University of New Hampshire
in Partial Fulfillment of
the Requirements for the Degree of

Doctor of Philosophy
In
Civil Engineering

May, 2013

This dissertation has been examined and approved.

Dissertation Director, Thomas P. Ballestero
Associate Professor of Civil Engineering

Robert M. Roseen
Adjunct Professor of Civil Engineering

Alison Watts
Assistant Research Professor of Civil Engineering

Mark E. Lyon
Assistant Professor of Mathematics and Statistics

Amy Clark
Professional Civil Engineer

Date

ALL RIGHTS RESERVED

© 2013

Iulia Aurelia Barbu

Dedication

To my Mom, for her sacrificial love.

Acknowledgements

I would like to thank the members of the UNH Stormwater Center group for the continuous help with this project. Particularly, I would like to thank my advisor Dr. Thomas Ballestero for providing guidance and expertise with this project, his mentorship in navigating the academic world, encouragement for my adventurous academic activities while at UNH, and brightening my days with his good humor and colorful Hawaiian shirts. I would like to thank also the members of my doctoral committee who made positive contributions to shape the final version of this dissertation.

Special thanks to my fellow graduate students: Pedro Avellaneda, George Fowler, Kris Houle, Josh Briggs, Nicholas DiGennaro, Ann Scholz, Robin Stone and Viktor Hlas with whom I shared the challenges and joys of graduate school. Many thanks to Ann and Robin for last minute proofreading, and to Tim for always being willing to help with instrument calibration and gathering data, no matter the weather conditions. I would like to thank my many friends at UNH, the Graduate Christian Fellowship group and the Seacoast Calvary Chapel community for being my second family, my home away from home during graduate school. Finally, I would like to thank my family for their support and their encouragement to pursue my dreams.

Funding for this project was provided by the Cooperative Institute for Coastal and Estuarine Environmental Technology (CICEET), the National Oceanic and Atmospheric Administration (NOAA) and the Great Bay National Estuary Research Reserve (GBNERR).

List of Tables

Table 1 – The particle size distribution for the sandy gravel used as filter media in the PP system.	13
Table 2 – The time difference from the beginning of precipitation event to the VMC response at different levels in the PP system.	21
Table 3 – Seasonal variation in volumetric moisture content in the PP system’s sublayers	25
Table 4 – Temperature variation in the PP system sublayers	25
Table 5 – Comparison of the porosity of the filter media soil and the observed VMC....	28
Table 6 – Average values of the initial, maximum and the change in the VMC during precipitation events	30
Table 7 – Van Genuchten fitting parameters	52
Table 8 – The goodness of fit of the interpolated and Van Genuchten curves to the measured data: the coefficient of determination (r^2) and root mean square error (RMSE).	55
Table 9 – Extended $\theta - \psi$ data points for the fine and coarse gravel soil fractions.....	61
Table 10 – Soil properties for the four types of filter media	61
Table 11 – Arya-Paris model sensitivity analysis with respect to the number of intervals	64
Table 12 – Arya-Paris model scaling parameters	64
Table 13 – Segments of flow identified in the PP system, recommended equations and data input needed	86
Table 14 – The “goodness of fit” analysis for routing stormwater through the filter media of the Alumni lot with Richard’s Equation and Barbu framework for obtaining the $\theta-\psi-K_r$ curves (Barbu and Ballesterro, 2013b), and the initialization parameters.	101
Table 15 – The “goodness of fit” analysis for the flow modeled with Glover Equation, Manning Equation, and flow at the bottom of the filter media layer, compared with the observed flow at the end of the subdrain	104
Table 16 – Total stormwater volumes computed as the cumulative area under hydrographs generated at the bottom of the filter media, and at the end of the pipe (Glover Equation). These are compared with the total volume observed at the end of the subdrain, and total precipitation fallen on the pavement surface.....	110
Table 17 – The power function coefficients for the family of curves presented in Figure 38.....	115

List of Figures

Figure 1 – The cross section of the PP system studied and the location of the four 5 TE Decagon moisture/temperature/conductivity probes (Ports 1 - 4). Duplicate probes are installed at each location.	11
Figure 2 – Installation of the 5TE probes at the bottom and middle of the filter media layer (Port 2 and Port 3). Half cut, stone filled pipe on the right side of the right figure is a positive pressure water sampler.	13
Figure 3 – Soil specific calibration for the 5TE Decagon probes developed for the bulk and fine fraction of the soil used as a filter media in the permeable pavement system....	15
Figure 4 – Nonexceedance probability of daily precipitation for Durham, NH over the entire gage record and for the study location from October 29, 2010 to January 11, 2012.	17
Figure 5 – Volumetric moisture content estimated from probe signals and converted with the original Topp Equation and the soil specific soil equation developed	18
Figure 6 – Peak moisture content at different levels in the PP system, generated by the infiltration of natural precipitation. Saturation in the filter media layer occurs at 29% VMC.	20
Figure 7 – The volumetric moisture content and temperature for Port 2 for below-freezing conditions. Saturation in this layer occurs at 29% VMC.....	24
Figure 8 – Exceedance probability curves for the VMC monitored by the four ports and VMC at saturation in the filter media soil.	27
Figure 9 – The fluctuation of the VMC in the PP system’s sublayers during the largest storm. Saturation occurs at 29% VMC.	29
Figure 10 – The fluctuation of the VMC at the top (Port 1) and middle (Port 2) of the filter media during the most intense storm. Saturation occurs at 29% VMC. VMC data for probes 3 and 4 was not available for this precipitation event due to probe malfunctioning.	30
Figure 11 – Particle size distributions for the filter media in the PP, SF, GW and BS systems.....	44
Figure 12 – Similarity principle: transition from a particle size distribution (a) to a moisture retention curve (b), adjustments for gravel content with Bouwer Equation (b), and extension of the MRC beyond Arya-Paris applicability range (b).	49
Figure 13 – The volumetric moisture content with respect to the matric potential for the PP filter media.....	53
Figure 14 – The volumetric moisture content with respect to the matric potential for the SF filter media.....	53
Figure 15 – The volumetric moisture content with respect to the matric potential for the GW filter media.	54

Figure 16 – The volumetric moisture content with respect to the matric potential for the BS filter media.	54
Figure 17 – The fluctuation of the volumetric moisture content (θ) measured at three levels within the filter media of a pervious pavement system under natural precipitation	56
Figure 18 – Unsaturated hydraulic conductivity developed with Mualem’s Equation as applied to the measured and computed volumetric moisture content – matric potential curves.	58
Figure 19 – The particle size distribution for the BS filter media, developed after dry- and wet-sieving, and combustion of wood chips.	63
Figure 20 – The sensitivity analysis of the Arya-Paris model with respect to the number of intervals used for the particle size distribution data	65
Figure 21 – Cross section of the Alumni lot PP system and location of volumetric moisture content (VMC) sensors	75
Figure 22 – The cumulative frequency of the VMC at the top (Port 1), middle (Port 2) and bottom (Port 3) of the filter media layer, and at the top of the stone reservoir (Port 4) for one year of monitoring, compared to the measured VMC at saturation in the filter media soil.	75
Figure 23 – The cross section (a) and plan view (b) of the PP system at West Edge parking lot. The outflow hydrograph is measured at the end of the subdrain.	81
Figure 24 – Particle size distribution of the soils used as filter media in the West Edge and Alumni PP systems	83
Figure 25 – Comparison of the “bucket and stop watch” flow measurements and automated flow measurements recorded by ISCO bubblers coupled with a Thelmar weir and manufacturer’s rating curve	84
Figure 26 – Representation of θ through the filter media layer in space and time	88
Figure 27 – The particle size distribution (a) of the filter media soil in the West Edge lot and the resulting θ (ψ) and K_r (θ) curves (b) as derived after Barbu and Ballesterro, 2013b.	91
Figure 28 – The particle size distribution of the filter media soil in the Alumni lot (a), and the θ (ψ) curve obtained by interpolation and fitted with VG Equation to the A-P generated data points (b)	94
Figure 29 – The θ (ψ) and K_r (θ) curves for the Alumni lot filter media as derived with Barbu methodology (Barbu and Ballesterro, 2013b)	95
Figure 30 – The VMC in the filter media soil profile in response to the 11/04/2010 precipitation event (total depth of 3 cm). $K_{sat} = 0.75$ cm/min. θ initial was set to observed VMC values at each level	97
Figure 31 – The moisture gradient in the top half and bottom half of the filter media, computed as the difference between the VMC at the upper and lower boundaries of the two halves of the filter media.....	99

Figure 32 – Moisture content fluctuation in the filter media in response to the 07/23/2009 storm event ($dt = 1$ min, $dz = 2.5$ cm (1’’)). Saturation occurs at 27%.	107
Figure 33 – Observed outflow hydrograph as compared to the modeled outflow for the West Edge system computed with Glover and Manning Equations for subdrains, and with Richards’ Equation as draining at the bottom of the filter media	108
Figure 34 – The peak moisture content at the bottom of the filter media layer for various thicknesses, in response to a 2.5 cm Type II – SCS design storm.....	112
Figure 35 – Peak flow lag times of as a function of the filter media thicknesses.....	112
Figure 36 – The peak moisture content at the bottom of a 30 cm filter media layer for various filter media saturated hydraulic conductivities, in response to a 2.5 cm Type II – SCS design storm.....	114
Figure 37 – Peak flow lag times for varying filter media K_{sat} in response to a 2.5 cm Type II – SCS design storm	114
Figure 38 – Lag time through the filter media for permeable pavement systems with various thicknesses and hydraulic conductivities	115

Table of Contents

Dedication	iv
Acknowledgements	v
Abstract	xiii
CHAPTER I	1
CHAPTER II	3
II.1 Introduction	4
II.2 Background	5
II.2.1 Water flow in soils	8
II.3 Methods and Materials	10
II.3.1 Moisture content measurements with Decagon devices	13
II.3.2 Precipitation data	15
II.4 Results and Discussion	17
II.4.1 Volumetric moisture content equations for the 5TE Decagon probes	17
II.4.2 Flow through the system and residence time	19
II.4.3 Water residence time in the system	22
II.4.4 Seasonal variability of the VMC	23
II.4.5 Volumetric moisture content range in the filter media	25
II.5 Conclusions	30
CHAPTER III	33
III.1 Introduction	34
III.1.1 Unsaturated flow functions	37
III.1.2 The moisture retention curves: $\theta(\psi)$	39
III.1.3 The unsaturated hydraulic conductivity curves: $K_r(\theta)$	40
III.1.4 Applicability of traditional MRC models to SWM filter media	42
III.2 Materials and Methods	45
III.2.1 Particle size distributions	45
III.2.2 Arya – Paris Model	45
III.2.3 Correction for coarse particles	48
III.2.4 Curve fitting	50
III.2.5 Testing data	50

III.3 Results and Discussions	51
III.3.1 The K_r function	58
III.3.2 Gravel content compensation.....	59
III.3.3 A-P Model sensitivity with respect to number of intervals and α computation	63
III.3.4 Model limitations and error	65
III.4 Conclusion	66
CHAPTER IV	69
IV.1 Introduction.....	70
IV.1.1 Pervious pavement types and configurations	72
IV.1.2 Segments of flow and corresponding equations	73
IV.2 Materials and Methods	80
IV.2.1 Site description	80
IV.2.2 Monitoring and data calibration.....	83
IV.2.3 Model development	84
IV.3 Results and Discussions.....	92
IV.3.1 Derivation of the θ - ψ - K_r functions for the Alumni lot.....	92
IV.3.2 Water routing through the filter media – Alumni lot.....	95
IV.3.3 The complete PP system model – West Edge lot	102
IV.3.4 Design variables effects on lag time through the filter media	110
IV.4 Conclusions.....	116
CHAPTER V	117
Summary and Conclusions	117
References.....	121
Appendix A: Storm events inventory analyzed for the Alumni Lot study (Chapter II)	130
Appendix B: Design Precipitation – Durham, NH	132
Appendix H: Storms used for the model calibration of the West Edge PP system	133
Appendix I: Storms used for the calibration of the Alumni Lot - filter media model	134
Appendix J: Calibration storms for the filter media of the Alumni Lot	135
Appendix K: Testing storms for the West Edge PP model.....	140

Abstract

DEVELOPMENT OF UNSATURATED FLOW FUNCTIONS FOR LOW IMPACT
DEVELOPMENT STORMWATER MANAGEMENT SYSTEMS FILTER
MEDIA AND FLOW ROUTINES FOR HYDROLOGICAL
MODELING OF PERMEABLE PAVEMENT SYSTEMS

By

Iulia Aurelia Barbu

University of New Hampshire, May 2013

Low Impact Development - Stormwater Management (LID-SWM) systems are relatively new technologies that were developed in order to meet the water quality criteria imposed by the Clean Water Act. LID-SWM is also used to replicate the natural hydrology of developed sites. However, the hydrological benefits of LID systems cannot be accurately predicted with the existing simulation models. Currently used software packages represent LID systems as storage units and do not specifically represent water routing through the systems' hydraulically restrictive sublayers. Since the LID's functionality at system level is not fully understood, the relationships of design variables and the systems' hydrological outcome were not yet empirically related.

In this dissertation, the appropriate equations for representing different flow components of LID systems are investigated. Special attention was given to modeling

water routing through the filter media layers of LID systems. The water movement through a permeable pavement system was monitored for over a year and it was found that the system functions under unsaturated conditions. Saturation was never observed at any levels in the system over the period of study. Solving Richards' Equation, which is typically used to represent flow in unsaturated soils, requires knowledge of the moisture characteristic curves, $\theta(\psi)$ and relative hydraulic conductivity, $K_r(\theta)$ functions. These functions are unique for each soil and have not been analyzed for coarse engineered soils used in stormwater treatment systems. A framework for computing the $\theta(\psi)$ and $K_r(\theta)$ functions for soils used as filter media for four LID systems (permeable pavement, sand filter, gravel wetland, and bioretention system) was developed and tested against laboratory measurements. This framework requires information on soils that is easily accessible to stormwater engineers (porosity and particle size distribution), and allows a detailed representation of filter media soils containing gravel and wood chips.

The $\theta(\psi)$ and $K_r(\theta)$ development framework used in conjunction with Richards' Equation performed well when tested against real time moisture profile in the sublayers of a permeable pavement system under natural precipitation. This framework for modeling flow through the filter media was integrated in a full permeable pavement system model.

CHAPTER I

Introduction

Objective of dissertation work

Low Impact Development - Stormwater Management (LID-SWM) systems are relatively new technologies. They were developed out of the need for more advanced treatment systems to address dissolved pollutants found in stormwater runoff, and to reduce volumes and delay peak flows of the stormwater runoff hydrographs generated by increasing urbanization. Quantifying the hydrological benefits of implementing LID-SWM technologies at site- and watershed-scale is typically performed with computer simulation models. Existing hydrological packages used in stormwater management design do not have the capabilities to route stormwater through the lower hydraulic transmissivity layers in LID systems. The few methodologies proposed for modeling LID systems assume that they function under saturated conditions or treat them as storage units, and do not specifically address the water routing through the filter media layers.

The objective of this dissertation work included: investigation of the nature of flow in a permeable pavement system's sublayers; development of a framework for modeling flow routing through the hydraulic control sublayers for four LID-SWM systems – permeable pavement, sand filter, gravel wetland and bioretention system; and testing of the proposed framework with data from two permeable pavement sites located on the University of New Hampshire campus.

Organization of dissertation

This dissertation has four chapters, three of them being stand-alone papers prepared for submissions to peer-reviewed journals. Chapter 1 gives an overview of the topic addressed in the dissertation work and the organization of the dissertation.

Chapter 2, “The investigation of the nature of flow in a permeable pavement system” is the monitoring study of the moisture transport in the Alumni lot permeable pavement installed on the University of New Hampshire campus. The pervious pavement at the Alumni lot does not receive run-on from adjacent impervious surfaces. Data from this site has shown that in the sublayers of permeable pavements water flows under unsaturated conditions.

Chapter 3, “Unsaturated flow functions for filter media used in Low Impact Development - Stormwater Management Systems”, presents a framework for developing the moisture retention curves, $\theta(\phi)$ and unsaturated hydraulic conductivity function, $K_r(\theta)$ for soil materials used as hydraulic controls in four Low Impact Development Stormwater Management systems: permeable pavement, sand filter, gravel wetland and bioretention system.

Chapter 4, “A physical model for stormwater flow simulation through a porous pavement system: relating the design parameters to the outflow hydrographs”, describes a framework for modeling the segments of flow identified in permeable pavement systems and the most appropriate equations to represent them. The sequence of equations proposed in Chapter 3 for the development of the $\theta(\phi)$ and $K_r(\theta)$ for the filter media soil of the PP system was tested.

CHAPTER II

The investigation of the nature of flow in a permeable pavement system

Abstract

Modeling and designing permeable pavement (PP) systems for hydrologic performance first requires the physical understanding of the nature of flow within the several layers that compose the system. The real time moisture flow transport through the sublayers of a permeable pavement parking lot installed at the University of New Hampshire was monitored for 14 months. The real time volumetric moisture content (VMC) data within the most hydraulically restrictive soil layers of the system, which controls the flow through the PP system, demonstrated that saturation was not achieved at any level, during or after natural precipitation events for the length of the study. The values of VMC in the filter media ranged from 4.3% to 20.2%, while the soils' saturation VMC was measured at 29%. Therefore, unsaturated flow equations (Richard's Equation) are more appropriate than saturated flow equations (Green and Ampt, Darcy) for routing stormwater through the filter media of permeable pavement systems. Winter data showed that residual water in the PP's sublayers freezes in extreme cold weather and VMC recorded with 5TE Decagon sensors were typically lower than in the summer months, even when frozen the layers maintained open pores capable of transmitting water. We also discussed calibration needs for VMC data collected with 5TE Decagon sensors for coarse engineered soils used for filter media in stormwater management systems.

II.1 Introduction

It is generally recognized that the strict water quality and quantity standards imposed by the Clean Water Act (CWA) can only be achieved with more advanced stormwater management technologies. These technologies are known as Low Impact Development - Stormwater Management (LID-SWM) systems or Green Infrastructure and consist of pervious pavements, bioretention systems, vegetated rooftops, gravel wetlands etc. (Roseen et al, 2006; UNHSC 2009, 2012). Permeable pavement systems (PP) are one especially valuable technology; they can serve both as traffic infrastructure and stormwater management practice (Schwartz, 2010). Extensive research on several PP systems at the University of New Hampshire Stormwater Center (UNHSC) have shown that PP systems have the capability to improve the water quality of stormwater runoff (Roseen, 2006; UNHSC, 2009b), and reduce the overall quantity of runoff discharged into surrounding water bodies by allowing infiltration in the native soils. In addition, PP systems may require a reduced amount of de-icing products than conventional pavements in cold climates (Houle, 2006). PP systems are recommended especially in low traffic zones like parking lots or highway shoulders (Ferguson, 2005).

Regardless of the water quality benefits provided by this technology, governmental agencies responsible for reviewing and approving stormwater management plans for construction projects that include LID-SWM systems can be reluctant to approve PPs as stormwater management strategies because of the lack of familiarity with the systems (Houle et al, 2013). Some designers struggle to demonstrate the hydrologic benefits of using PP systems as a functional stormwater management technology with currently available modeling tools: for example, representing the “outflow hydrograph”

for the system and showing that post-development peak flow is less than pre-development peak flow. The relationships of the system's design parameters to the final system outcome have not been yet empirically related for PP systems (Fassman and Blackbourne, 2010). Therefore, the understanding of flow through PP systems and its simulation with computer models currently used for designing and sizing of stormwater management systems have not advanced enough to predict how different system configurations and the use of filter media and underdrains alter the hydrographs flowing from a PP system, or other LID-SWM filtration systems for that matter.

II.2 Background

In current practice, the sublayers of PP systems are designed for traffic load, freeze-thaw, and draindown time (Schwartz, 2010). The water quantity and quality benefits of using filter media in PP systems are dependent on the type of media and sub-base configuration, but currently are not part of the main criteria considered in the system's design. The hydrological behavior of PP systems can only be observed by monitoring after the system is built, as there are presently no effective methods of predicting it before construction.

PP systems are very similar to conventional pavements. The difference is that the pavement layer is designed to allow storm water to infiltrate and pass into the sublayer materials instead of letting it run off. Another difference in cold regions is that the sublayer materials are hydrologically disconnected from the native soils below to minimize impacts of freeze-thaw cycles (Roseen et al, 2012). A PP system is represented

by a layer of pervious asphalt, concrete, or interlocking blocks on top of layered permeable materials. The sublayer structure provides both structural and hydrological functions, and its configuration varies depending on the project goals and site conditions. A typical sublayer configuration includes: a structural layer (choker course) – typically crushed stone – below the permeable surface layer; then a layer of coarse sand/fine gravel (bank run gravel) which serves as a filter media to remove pollutants and slow down the stormwater; and below that another layer of crushed stone which acts as a reservoir to hold water, prevent moisture from moving upwards (frost heave inhibition), allow it to move to underdrains, and/or hold it to allow for infiltration into the soil (Figure 1). At sites with very high permeability soils, the lower stone layer and drainage piping may be absent. Underdrains are placed in the stone layer at the base of the system if drainage control is needed in low permeability native soils or where infiltration is undesirable. Some designs might exclude the filter media layer, instead opting for only a crushed stone reservoir. As with any other filtration LID-SWM systems, the filter media provides significant water quality benefits through filtration and biological treatment processes. The use of a filter media layer in PP systems is also recommended to prevent clogging with fines at the interface between the system sublayers and the native soils (ACI, 2006).

A few suggested methodologies for assessing the hydrological response of PP systems include the SCS-Curve Number (CN) (Swartz, 2010), and/or the use of pond routing methodologies (Jackson and Ragan, 1974; Ladd, 2004; Barbu et al, 2009; Swartz, 2010). These approaches to the analysis of PP systems hydraulics are based on the assumption that the sublayers act as a storage unit with a void space equal to the porosity of the material, and therefore is modeled with stage-storage relationships and outlet

controls. This method is similar to modeling conventional stormwater management systems like detention/retention ponds and was adopted mainly because computer models available to stormwater management practitioners do not have the capabilities to model the more advanced processes that take place in PP systems (Elliot, 2006; Dietz, 2007). These methods might seem appropriate for systems with a sublayer composed only of crushed stone where the water flows freely through the stone, but are highly imprecise for systems that have a more complex configuration and include more hydraulically restrictive layers such as sand.

Some stormwater management software packages (EPA SWMM5 and PCSWMM) now include an LID toolkit with explicit tools for modeling PP systems and other filtration systems. The flow through the filter media is modeled with the Green-Ampt Equation which assumes saturated porous media flow. XPSWMM also developed a tool that allows the user to model PP systems as a storage unit, using stage-storage indication methods. Both these modeling approaches assume that the pore space in the soil is completely saturated with water during precipitation events.

The need for more physically-based models to route stormwater through filtration systems is recognized by scientists who go to great lengths in trying to adapt modeling capabilities of available software to mimic the hydrological behavior of filtration systems (Lucas, 2010; Aad et al, 2010). A few methods suggested for modeling the water movement through filter media include Darcy's Law (Lucas, 2010), original Green-Ampt (Dussailant, 2003; Jayasuriya, 2008; Aad, 2010) or modified Green-Ampt (Lee, 2011), and Richard's Equation (Dussailant, 2004; Browne, 2008). While Darcy's Law and

Green-Ampt are valid only for saturated flow, Richard's Equation is the only one that applies to unsaturated flow conditions.

II.2.1 Water flow in soils

The soil matrix is composed of solid particles and pore space which can be filled either with air or water. Some pores are connected to each other in a way that can transmit fluids, while other pores have dead ends and effectively transmit no fluid. The connected pores are known as the effective porosity of the soil. The tortuosity of the connected pores is dependent on soil texture and compaction. More compacted soils have less pore space available to transmit water. Similarly, when the gradation of the soil covers a wide range of particle sizes, the smaller particles fill the void space between the larger particles, decrease the pore space volume and increase the tortuosity of the flow path (Dane and Topp, 2002). Vertical water flow through soils is driven by gravity and can take place both under unsaturated or saturated conditions. When the pore space is only partially filled with water (unsaturated flow), the water moves at slower rates than when the pores are completely filled with water (saturated flow conditions) because permeability is directly related to moisture content. If the water input at the soil surface is greater than the soil's water transmission capacity, saturated conditions occur, and the water builds up (ponds) above the soil. In PP systems with layers of differing soil media, water could back-up (pond) above the least transmissive layer: the filter layer or the native soil at the bottom. An indication of saturation within the soil matrix is when the volumetric moisture content in the soil reaches the effective porosity value and then plateaus.

The most common equation used to represent saturated porous media flow conditions is Darcy's law (Darcy, 1856):

$$q = -K_{sat} \left(\frac{dh}{dz} \right)$$

Equation 1

Where:

q = Darcian flow (L/T); K_{sat} = saturated hydraulic conductivity (L/T); dh = change in energy that drives the flow (L) across dz = the length of porous media layer (L), z being the vertical direction here.

Unsaturated flow is successfully described with Richard's Equation, which is a combination of Darcy's law and the continuity equation for a partially saturated porous media:

$$\frac{\partial \theta}{\partial t} = \frac{\partial \left[D(\theta) \frac{\partial \theta}{\partial z} + K_r(\theta) \right]}{\partial z}$$

Equation 2

Where:

$\partial \theta$ = the change in volumetric moisture content (-); ∂t = the time interval for analysis (T);

∂z = the space interval/depth of layer (L); $\partial \psi$ = the change in matric potential (L⁻¹);

$K_r(\theta)$ = hydraulic conductivity (L/T); and $D(\theta)$ = water diffusivity (L²/T);

Solving Darcy's Equation requires knowing the hydraulic conductivity at saturation (K_{sat}), which is constant for a given soil and compaction degree. Solving Richard's Equation requires knowing the relative hydraulic conductivity (K_r) of the porous media. This changes with moisture content and so does the diffusivity (D) and the matric potential (ψ). As saturation decreases, K_r can decrease by orders of magnitude. In order to solve Richard's Equation, information is needed on how θ , ψ , and K_r relate to each other. The $\theta - \psi - K_r$ relationships are unique for each soil and degree of compaction. For any specific porous media, these relationships are highly nonlinear, non-unique, and difficult to accurately represent with a function for the entire range of values. The complexity of data input needed to solve unsaturated flow equations is the main drawback to employing unsaturated flow equations for modeling flow through PP systems.

The goal of this study is to improve the understanding of water movement through PP systems, investigate the nature of flow through the filter media under natural precipitation, and select the most appropriate equations for modeling the movement of water through the filter media of PP systems. This information will be useful for developing hydrological assessment methodologies for PP systems.

II.3 Methods and Materials

The study was conducted on a porous asphalt pavement parking lot installed on the University of New Hampshire campus in 2010. The PP system consists of a 10 cm (4") porous asphalt layer laid on top of a choker course consisting of 15 cm (6") of 2 cm

(3/4") crushed stone, 30 cm (12") bank run sandy gravel serving as the filter media layer, 10 cm (4") of 1 cm (3/8") crushed stone as a separation layer, and 30 cm (12") of 5 cm (2") crushed stone serving as an infiltration reservoir with 15 cm (6") diameter slotted drains installed at the top of the stone reservoir (Figure 1). The system was built in a native sandy soil, based on the PP systems design specification developed by the UNHSC (UNHSC, 2009a), with seasonally high water table.

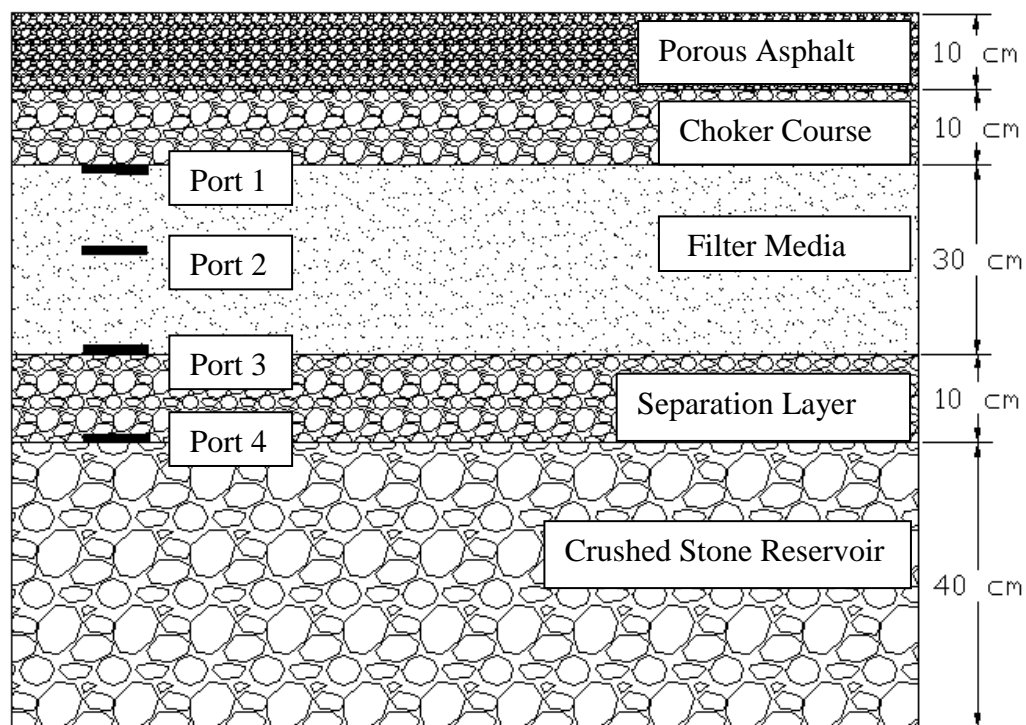

Figure 1 – The cross section of the PP system studied and the location of the four 5 TE Decagon moisture/temperature/conductivity probes (Ports 1 - 4). Duplicate probes are installed at each location.

In order to track the moisture movement through the system, four 5TE Decagon multi-sensor probes were installed at different levels in the PP system. The probes were placed at the top, middle, and bottom of the filter media layer and at the bottom of the crushed stone separation layer placed between the filter media and the infiltration

reservoir. VMC, temperature, and specific conductivity were measured in real time at 5 minute intervals and stored with an Em50 data logger. The setting of two of the 5TE probes is shown in Figure 2. Since the filter media is the most flow restrictive material in the system, special attention was given to the probes installed in this layer. The soil characteristics of the bank run gravel used as filter media are presented in Table 1. The gravel layer was compacted to 92% of maximum density measured with the Modified Procter test. The porosity was computed according to ASTM 7263, and was found to be 32.8% by volume. Using the Vukovic Equation (Vukovic and Soro, 1992), porosity was calculated as 34.4%.

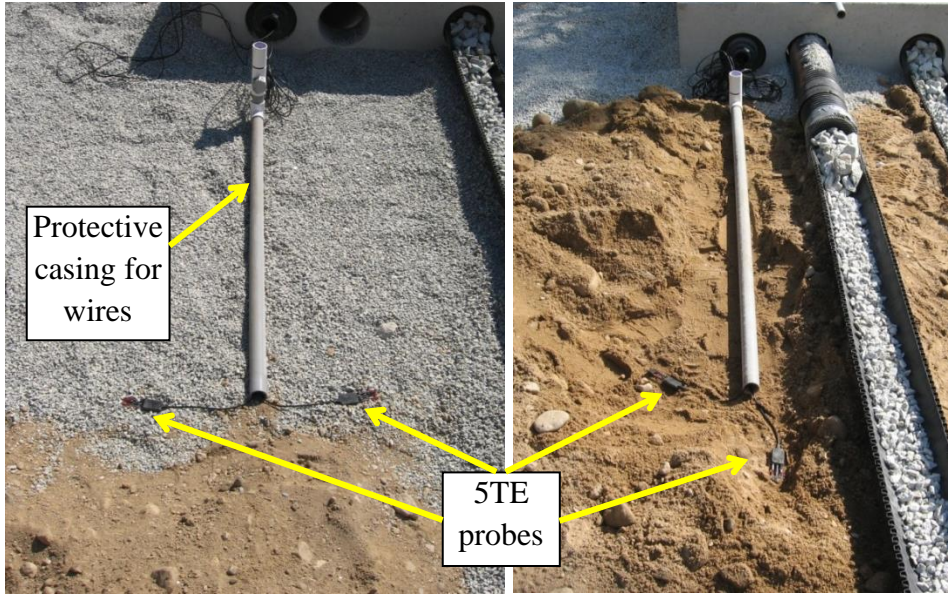

Figure 2 – Installation of the 5TE probes at the bottom and middle of the filter media layer (Port 2 and Port 3). Half cut, stone filled pipe on the right side of the right figure is a positive pressure water sampler.

Table 1 – The particle size distribution for the sandy gravel used as filter media in the PP system.

Sieve Size (mm)	Sieve Size (in)	Percent Finer (%)
38.1	1 1/2"	100.00
19.0	3/4"	96.13
12.5	1/2"	93.93
6.3	1/4"	90.79
4.75	#4	84.41
2	#10	80.86
0.85	#20	66.95
0.425	#40	35.77
0.18	#80	10.98
0.15	#100	2.09
0.075	#200	1.57
<0.075	pan	0.42

II.3.1 Moisture content measurements with Decagon devices

The 5TE Decagon probes measure VMC, temperature, and specific conductivity with three individual probes. The VMC is measured as a dielectric constant, using

capacitance domain technology; temperature is measured with a thermistor; and specific conductivity is measured with a stainless steel electrode array (Decagon, 2011). In order to obtain the actual VMC in the soil, the dielectric constant reading from the probe is automatically converted to VMC through the data management software ECH₂O using the Topp Equation (Topp et. al, 1980):

$$\theta(m^3/m^3) = 3.44 * 10^{-11} * Raw^3 - 2.2 * 10^{-7} * Raw^2 + 5.84 * 10^{-4} * Raw - 5.3 * 10^{-2}$$

Equation 3

Where: *Raw* = the direct output of the 5TE dielectric probe.

Topp's Equation was developed on over 2000 soil samples ranging from clay soils to sandy soils. Literature shows that for improved data accuracy, soil specific calibration and even sensor specific calibration are needed (Rosenbaum et. al, 2010). The filter media in the PP system contains a significant amount of coarse particles and there was a concern that the gravel would influence the readings of these probes. In order to verify the applicability of Equation 3 to the PP filter media and the gravel particle effect on the 5TE probe readings, a soil-specific calibration test was measured in the laboratory. The soil samples were progressively wetted with known volumes of water up to the saturation point, while the probe's dielectric signal was recorded. A soil specific equation was then developed with regression analysis.

Two soil specific equations were developed for the bulk soil and for the fine fraction that remained after removing all particles larger than 2mm, respectively. Calibration data presented in Figure 3 shows that there is no significant difference

between the two equations and that particles larger than 2mm did not influence the moisture content readings of the 5TE probes for this soil. The equation developed on the bulk sample of the soil was further used to convert the raw data to VMC for the filter media:

$$\theta(m^3/m^3) = 0.0004 * Raw - 0.0771$$

Equation 4

Where: Raw = the direct input from each of the 5TE dielectric probes

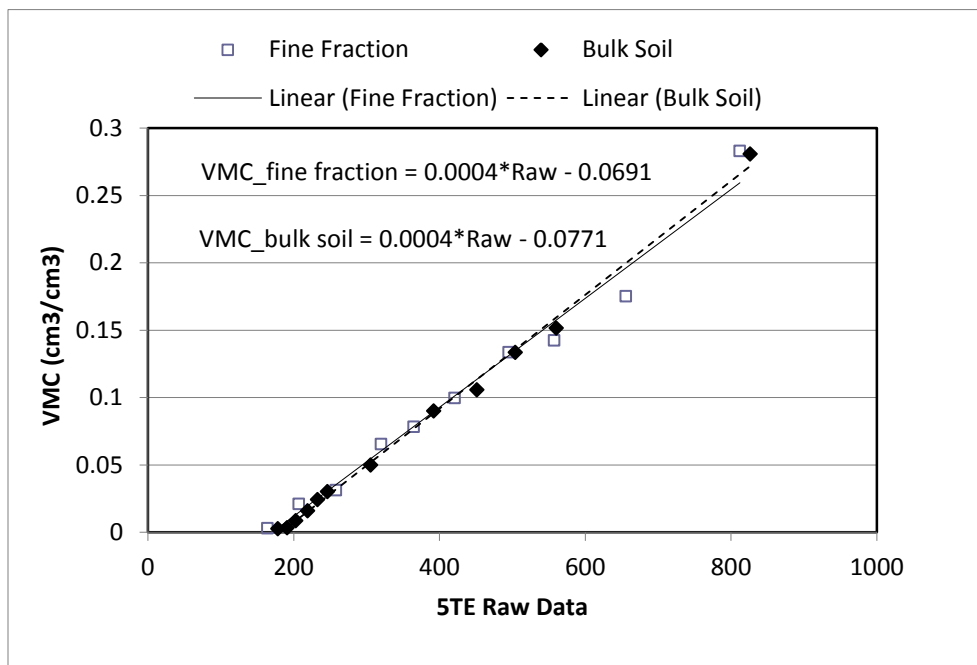

Figure 3 – Soil specific calibration for the 5TE Decagon probes developed for the bulk and fine fraction of the soil used as a filter media in the permeable pavement system

II.3.2 Precipitation data

In order to capture the seasonal variation of climate conditions, precipitation and moisture content data in the PP system’s sub-base was collected from October 29, 2010

to January 11, 2012. Precipitation data was collected with a NOAA rain gage located 2.4 km (1.5 miles) away from the location of the study site. The total amount of precipitation recorded was weighted on an annual basis at 1057 mm (41.6 “) per year. Compared to the annual average for the geographical area of 970 mm (38.2”) (NOAA, 2012), this would indicate that the period of study was slightly wetter than normal. However, when comparing the nonexceedance probability distribution of the daily precipitation data for Durham, NH (the NOAA gage) from 1915 to 2007 to that of the precipitation recorded for the period of this study (Figure 4) as developed with Weibull formula (Weibull, 1939), the daily average precipitation during this particular year was lower than in an average year and it was a few extreme events that made the annual amount larger than the long term average annual amount. Over the monitoring period, there were a total of 46 storm events that generated a response in the moisture content in the filter media. Scattered precipitation amounts that did not cause a change in the moisture content or that generated a response for only a very short period of time were not categorized as precipitation events for the purposes of this investigation. The inventory of the 46 storm events is presented in Appendix A.

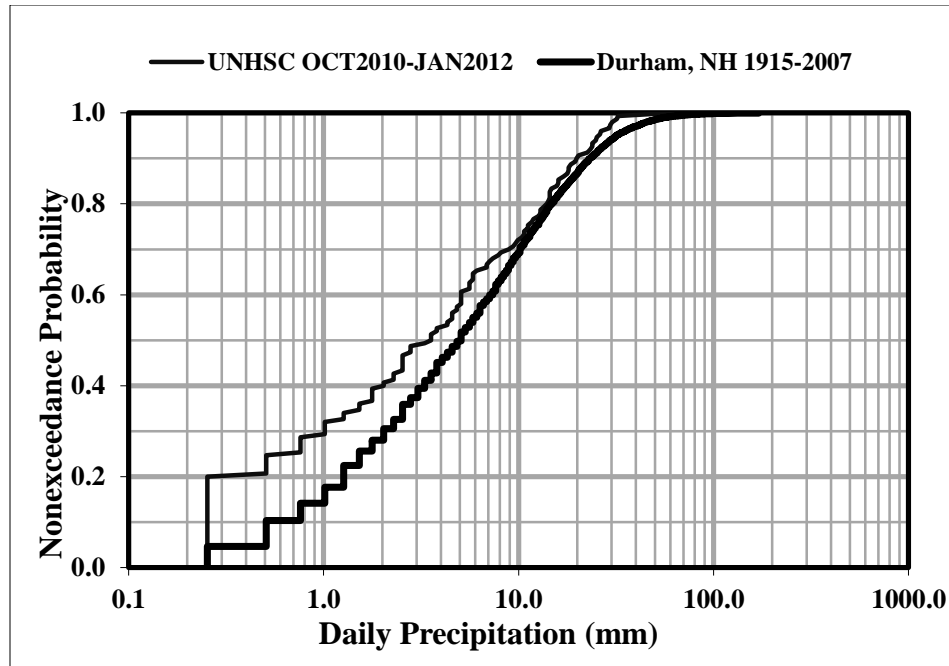

Figure 4 – Nonexceedance probability of daily precipitation for Durham, NH over the entire gage record and for the study location from October 29, 2010 to January 11, 2012.

II.4 Results and Discussion

II.4.1 Volumetric moisture content equations for the 5TE Decagon probes

The VMC at the bottom, middle and the top of the filter media layer were recorded at five minute intervals. Figure 5 shows the VMC data obtained with the Topp Equation (Equation 3) and with the soil specific equation developed for the sandy gravel - filter media in the PP system (Equation 4). It is apparent that Equation 3 consistently overestimated the actual moisture data by approximately 5% of the actual VMC (Figure 5). Given that the range in moisture content through the study period was somewhere between 1.4% and 20.2% (Equation 4), and 6.9% to 24.7% (Equation 3), the actual VMC error introduced by using the Topp Equation for this soil ranges from 24% to 29%. This is the equivalent of 232 to 284 millimeters of rainfall on an annual basis.

The close resemblance of the two soil specific calibration equations developed for the bulk sample and the fine fraction of the sandy gravel suggests that these equations may be used for similar studies of coarse filter media containing various ratios of sand and gravel. Either one of the two developed equations (Figure 3) is recommended as an alternative to the Topp Equation (Equation 3) for disturbed and repacked sandy and gravely soils used in stormwater management applications.

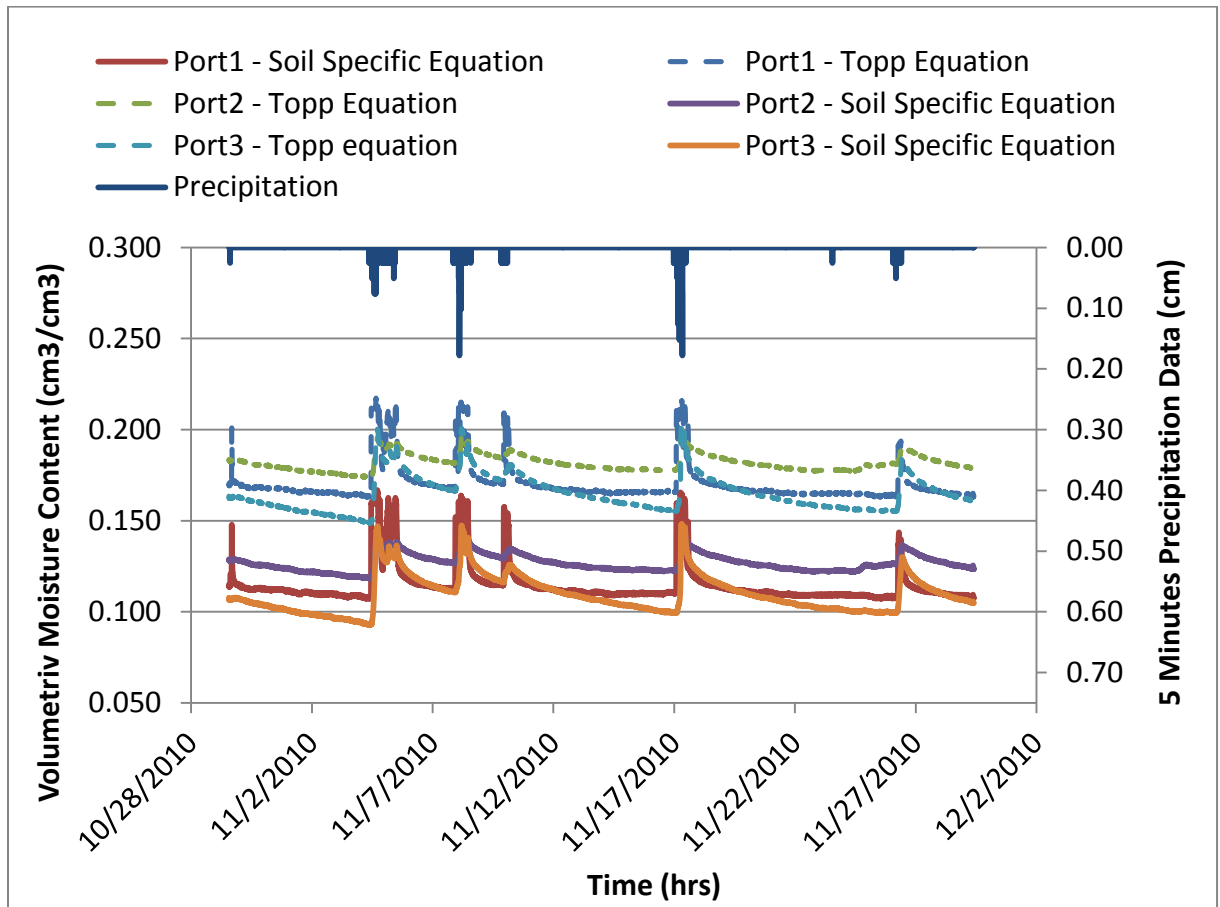

Figure 5 – Volumetric moisture content estimated from probe signals and converted with the original Topp Equation and the soil specific soil equation developed

II.4.2 Flow through the system and residence time

The range of the VMC in the filter media at different levels was somewhat dissimilar (Table 3). The values for the VMC in the middle of the filter media were consistently higher than the VMC at the top and the bottom of that layer. This can be attributed to the fact that the 5TE Ports 1 and 3 were placed in the vicinity of coarser soils layers and the probes readings extended beyond the filter media boundaries. The range of influence of 5TE probes is approximately 0.3 liters which can be illustrated by a cylinder with a radius of 2 centimeters around the probe. Coarser soils have a lower water retention capacity and the mixed signal from the two layers with different porosities would explain why the VMC recorded by Ports 1 and 3 were lower than the VMC recorded in the middle of the filter media layer. Probe 2 which was completely surrounded by the bank run gravel is considered to give a clearer picture on the nature of flow in the filter media than probes 1 and 3. Another case can be made for the fact that engineered soils are not completely homogeneous and uniform densities usually are difficult to obtain in the field and this might have influenced the actual VMC at different locations.

However, the VMC from the four probes gives significant insight in the water movement in the PP system's sub base which can be tracked by means of peak moisture values through the system. The peak moisture content occurrence at the four levels in the system in response to precipitation is exemplified in Figure 6 which shows part of the May 14, 2011 precipitation event.

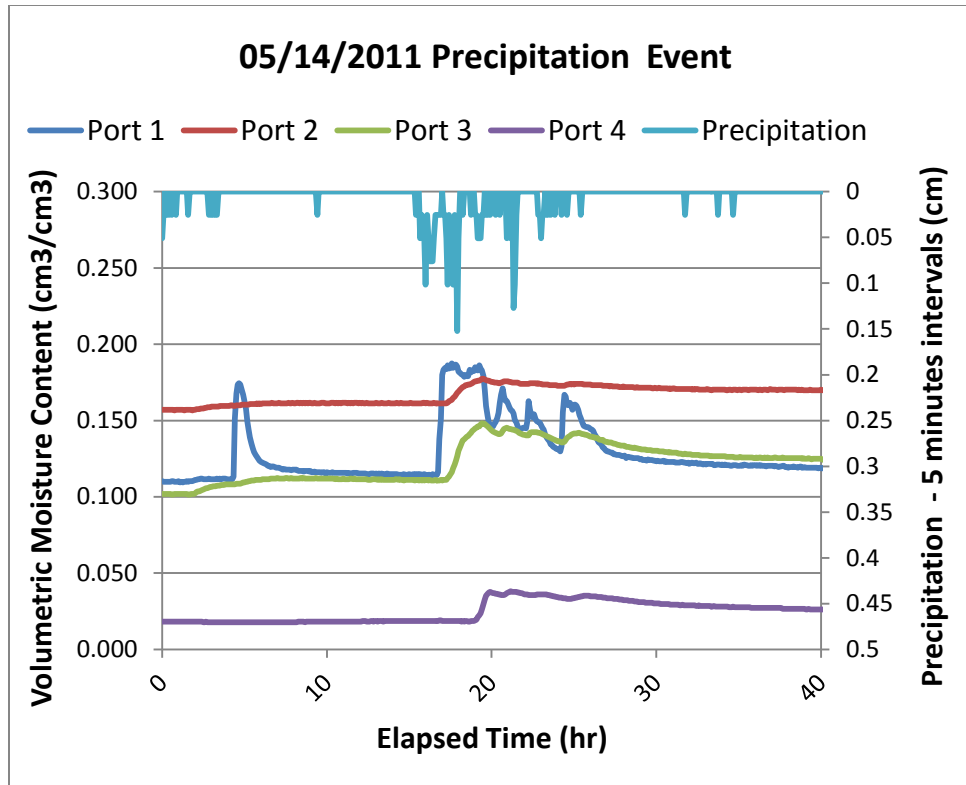

Figure 6 – Peak moisture content at different levels in the PP system, generated by the infiltration of natural precipitation. Saturation in the filter media layer occurs at 29% VMC.

The lag time between the beginning of the precipitation event and the response of the VMC in the system’s sublayers was analyzed for each precipitation event. The average lag time for Port 1, Port 2 and Port 4 were 2.45, 3.48 and 7.61 hours, respectively (Table 2). Port 3 had multiple data gaps due to probe malfunctioning and there were not sufficient storms to generate an unbiased lag time value for this location. If the system were to function under saturated conditions, it would take only 8 minutes for the moisture to travel through the entire filter media layer (Port 1 to Port 3) based on the $K_{sat} = 3.6$ cm/min measured for the bank-run gravel, rather than the observed average of 2 hours.

In order to generate a response in the VMC at Port 1, the precipitation needs to travel through 10 cm of pervious asphalt and 10 cm of 2 cm diameter crushed stone. Infiltration rates for pervious asphalt and pervious concrete pavements are typically in the range of 1,250 to 10,000 cm per hour (UNHSC, 2012) as measured with double ring infiltrometers or other testing methods that create ponding conditions on top of the pavement’s surface (Ferguson, 2005). Infiltration rates for crushed stone are around 4,000 cm/hour and generally it is assumed that these two top layers of a PP system can easily absorb the natural occurring precipitation rates which are significantly smaller than their infiltration capacity. In addition, their pore sizes are sufficiently large that there does not appear to be a capillary barrier effect. When modeling PP systems, the travel time through these coarse materials is often assumed insignificant when compared to the travel time through the more hydraulically restrictive layers and is not explicitly modeled. Commonly, when modeled, precipitation is considered to accumulate directly at the bottom of the system or on top of the most impermeable layers without delays (Jackson, 1974; Ferguson, 2005). However, real time data (Table 2) shows that the time to travel through the pavement and chocker course could contribute significantly when evaluating the lag time for the entire system.

Table 2 – The time difference from the beginning of precipitation event to the VMC response at different levels in the PP system.

Lag Time (hours)	Port 1	Port 2	Port 3	Port 4
Average	2.45	3.48	N/A	7.97
Minimum	0.25	0.50	0.58	0.75
Maximum	9.83	14.42	7.92	23.08

The difference in lag time between Port 1 and Port 2 can be used to estimate the average hydraulic conductivity rates in the filter media layer. The design specification for

the filtration layer requires the saturated hydraulic conductivity to be between 3 to 18 meters per day (10 to 60 ft/day) (UNHSC, 2009a). With an average lag time between Port 1 and 2 of 1:09 hours and a distance of 15 cm, the average unsaturated hydraulic conductivity of the soil was 3.35 meters/day (11ft/day). This is the hydraulic conductivity corresponding to a VMC of 17.5% for this soil, based on the measured unsaturated hydraulic conductivity test performed on this soil in a parallel study (Barbu, 2013). This would imply that the actual saturated hydraulic conductivity is above the minimum value required by design standards, but that in practice, if systems are designed at the low end of the required range, the actual unsaturated system performance could easily miss the minimum target. Testing of permeability on each material layer during construction phase is typically performed with inundation tests, which create saturated condition at least at the surface of the soil tested.

II.4.3 Water residence time in the system

Typical PP system design standards require that the system completely drains down in 1 to 5 days (Leming et al, 2007), which represents the mean time between precipitation events in most geographical areas in the U.S. The more frequent design standard is for the system to drain down the 10-year 24-h design storm in less than 72 hours (Schwartz, 2010). The residence time in the PP system in our study was analyzed for each storm, by tracking the time it took for the VMC in the filter media to return to the initial moisture content of the soils recorded at the beginning of the storm. The average time was 3.04 days, with a minimum and maximum value of 0.39 and 7.52 days, respectively. For some storm events, the VMC did not return to the initial value before the next precipitation event.

II.4.4 Seasonal variability of the VMC

Freeze-thaw phenomenon is a concern in PP systems as well as in conventional pavements. During extreme cold weather, as water infiltrates into the sub-base of pavements and freezes, its volume expands and could potentially cause damage in the pavement layer as well as disturb the sub-base materials. Because of the free draining nature of PP system's sublayers as well as the intentional use of a lower stone layer to act as a capillary barrier, frost heave is not typically an issue in PP systems, even though the PP systems freezes prior to nearby soil (Roseen et al, 2012).

In this study, the values of the VMC in the cold months for the four probes were generally lower than those in warm months (Table 3). This is because some of the residual water held by the soil particles was frozen and was sensed by the probes as solids. However, the fluctuation of the moisture content during the precipitation events is evidence that the pore space in the soil was not completely occupied by frozen water, and that the soil still maintained opened pores capable of transmitting water. The latent heat of the infiltrating stormwater caused the temperature in the system to rapidly increase and melt some of the ice formed in the soil's pores during infiltration into the frozen filter media layer (Figure 7), therefore changing the VMC over the course of the storm. Although the air temperature was above freezing and the atmospheric conditions caused rainfall instead of snowfall, the temperature in the soil was still below freezing (Roseen et al, 2012). The VMC for storm events for which the temperature recorded in the PP system's filter layer were below-freezing were analyzed separately from above-freezing events and are presented in Table 3.

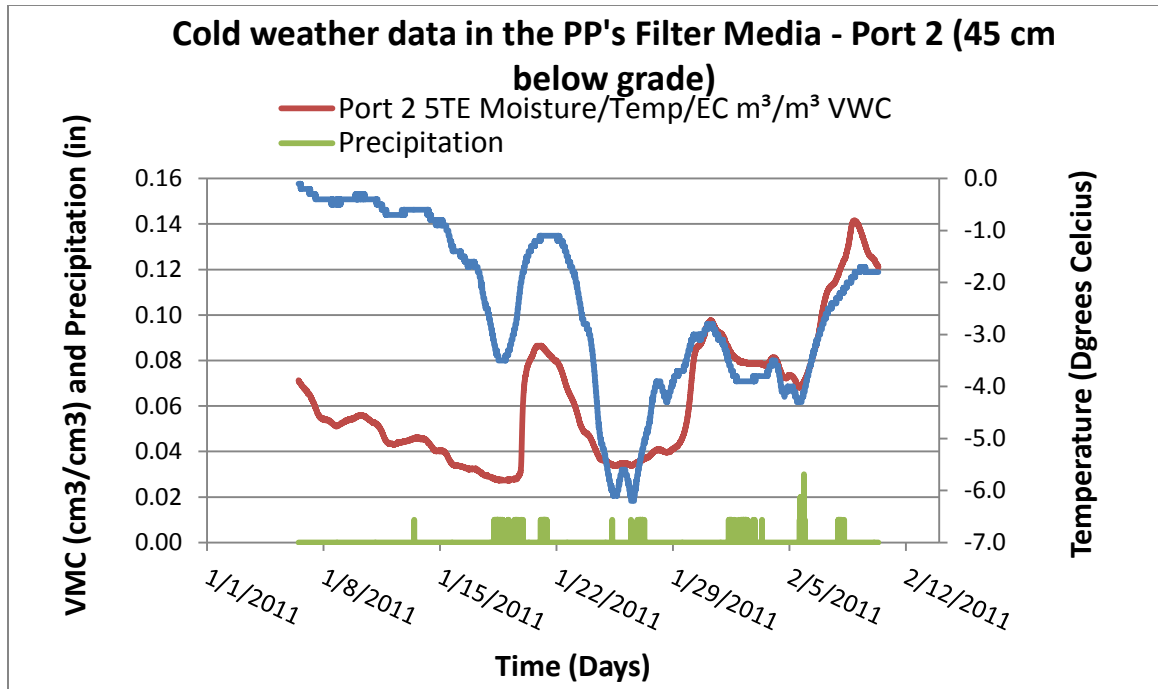

Figure 7 – The volumetric moisture content and temperature for Port 2 for below-freezing conditions. Saturation in this layer occurs at 29% VMC.

The temperatures at different levels in the PP sublayers are analyzed and summarized in Table 4. As expected, the temperature variation in response to air temperature fluctuation was smaller in the deeper layers of the system. The temperature in the lower layers was colder in the summer time and warmer in the winter time when compared to the temperature at the top of the system (Port 1). One noteworthy observation is that the top layers of the system – the pavement and choker layers – heat up above the air temperature during the summer months due to solar radiation and consequently transfer the heat to any infiltrating stormwater. The highest temperature in the system over the study period was 41.8 °C, recorded at Port 1, which is located 20 cm under the surface of the pavement. The maximum air temperature recorded for that period was only 37.6 °C.

Table 3 – Seasonal variation in volumetric moisture content in the PP system’s sublayers

	Above Freezing Temperatures				Below Freezing Temperatures			
	Port 1	Port 2	Port 3	Port4	Port 1	Port2	Port 3	Port 4
Min – VMC (%)	8.9	7.4	9.1	5.2	4.1	4.3	1.4	2.6
Max – VMC (%)	20.1	20.2	15.2	10.1	18.3	20.2	16.1	8.1
Range of VMC (%)	11.2	12.8	6.1	4.9	14.2	12.8	14.7	5.5

Table 4 – Temperature variation in the PP system sublayers

	Port 1	Port 2	Port 2	Port 4
Min – Temperature (°C)	-8.1	-6.2	-6.1	-2.7
Max – Temperature (°C)	41.8	37.8	30.9	28.0
Average – Temperature (°C)	13.2	13.4	8.8	8.5
Average – Summer Temperature (°C)	29.4	29.1	26.8	25.3
Average – Winter Temperature (°C)	-1.5	-0.7	-0.3	1.1

II.4.5 Volumetric moisture content range in the filter media

The PP system for this study does not receive run-on from surrounding impervious areas, which means that it has a 1:1 drainage area to filter area ratio. One of the main goals of this study was to investigate whether the filter media reaches saturation at any time. Two different tests performed on the filter media soil compacted at field conditions resulted in moisture content at saturation to be 29.3% and 28.29% respectively. The first measurement was part of an unsaturated hydraulic conductivity test, and the second measurement was taken during the inundation test performed when the soil specific equations were developed for the 5TE probes. Given the close agreement

of the two measurements, it is conservative to say that the saturation of the filter media soil at field compaction takes place at 28-29% VMC.

Probe 2 is considered to be most representative of the flow conditions in the filter media soil because its zone of investigation is entirely within the filter media. This probe is located in the middle of the filter media and it is unlikely that its signal reaches into the adjacent layers as is the case for probes 1 and 3. The values of the calibrated VMC data for the combined seasons in the middle of the filter media layer ranged from 4.3% to 20.2%. When compared to the computed porosity, effective porosity, and saturation moisture content (Table 5), it is apparent that the filter media was far from reaching saturation during the period of study. This is also supported by the comparison of the cumulative probability distribution for the VMC at this location to the VMC at saturation.

In below-freezing temperature, as some of the residual water in the soil freezes, the pore space is less than that of unfrozen soils. The 5TE probes sense the frozen water as solids, and their readings might not be an accurate measure of the actual VMC in the soil. The amount of solid water and that of the opened pore space fluctuates during a runoff event: as warmer stormwater infiltrates and increases the temperature in the PP system's sublayers. Although we could not obtain a measurement of the effective porosity of the frozen soils, we looked for any other signs of saturation. If, during a recharge event, the VMC reached the effective porosity, it would plateau at that maximum value until recharge slowed or ceased, and this was never observed at any point for below-freezing temperatures, or above-freezing temperatures for that matter.

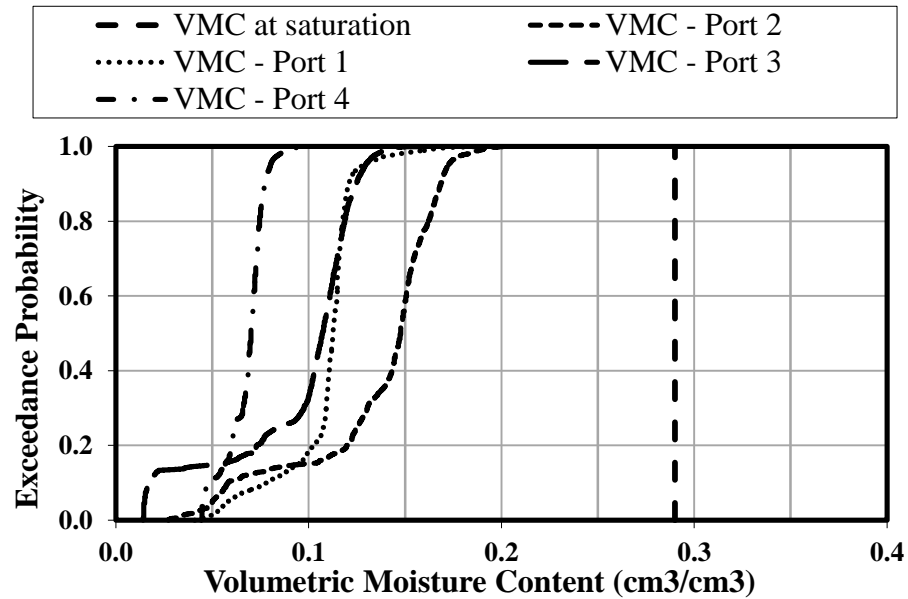

Figure 8 – Exceedance probability curves for the VMC monitored by the four ports and VMC at saturation in the filter media soil.

Generally, the coarse soils with uniform particle gradation like those used as the choker course and separation layer have higher permeability rates and hydraulic conductivities than the soil used as the filter media. Since probes 1 and 3 were likely receiving a mixed signal from coarser adjacent layers and the filter media, and probe 4 was placed in the separation layer itself, we assumed that the saturation at these three locations should be at least the same as for the filter media (but realistically most likely higher). The cumulative frequency distribution for the VMC for each of the four probes, as shown in Figure 8, suggests that saturation did not occur at any level in the sublayers of the system for the period of study. It is also apparent that the layers underlying the filter media do not reach saturation (based on VMC from Port 4), and this is most likely because the filter layer is throttling the flow through the system.

Table 5 – Comparison of the porosity of the filter media soil and the observed VMC

Effective Porosity range for gravels (%) (Fetter, 1988)	Computed Porosity (%) (Vukovic Eq.)	VMC at Saturation (%) (measured)	Max. VMC (%) (observed)	Min. VMC (%) (observed)
25 - 35	34	28 - 29	20.2	4.3

The moisture changes in the filter media in response to the largest (5/14/2011) and most intense (8/27/2011) precipitation events for the period of study were evaluated for any signs of saturation. The moisture profile in the PP system’s sub-base for these storms is presented in Figures 9 and 10.

The largest event (5/14/2011) registered 7.39 cm (2.89 in) of precipitation over a period of five days. The maximum VMC increase (6.6%) was recorded at the top of the filter media and corresponded to a maximum precipitation intensity of 0.7 cm/hour (0.27 in/hour). The maximum VMC was of 18.3%, which is well below the saturation VMC. The most intense event (8/27/2011) recorded rainfall intensities of a 1 year-12 hour storm, based on rainfall frequency data developed by the Northeast Regional Climate Forecasting Center with precipitation data recorded until 2010 (Appendix B). During this storm event, the maximum VMC increase (6.3%) was also recorded at the top of the filter media, and corresponded to a maximum precipitation intensity of 0.97 cm/hour (0.38 in/hour). The maximum VMC was recorded as 18.0%. No saturation was observed at any levels in the system even during the largest and the most intense storm events.

Averages of the initial and maximum VMC, and the average change in VMC for all other storm events are presented in Table 6, and a summary of the storm events characteristics are shown in Appendix A.

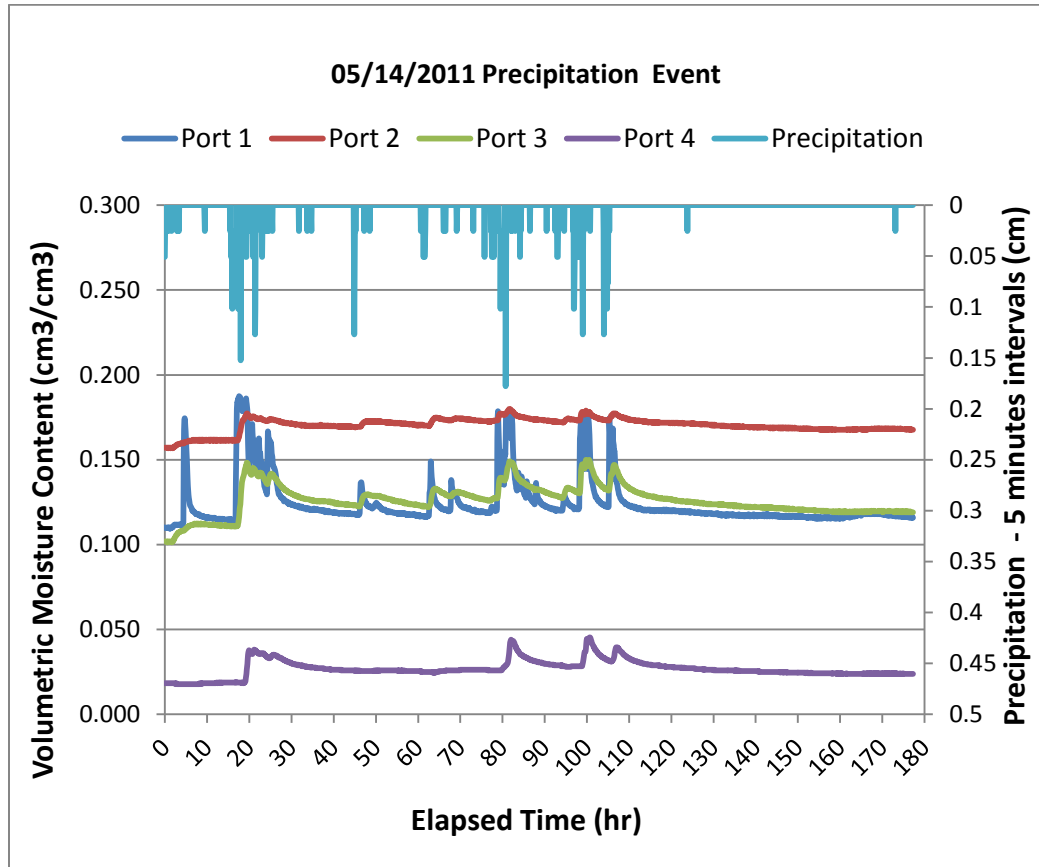

Figure 9 – The fluctuation of the VMC in the PP system’s sublayers during the largest storm. Saturation occurs at 29% VMC.

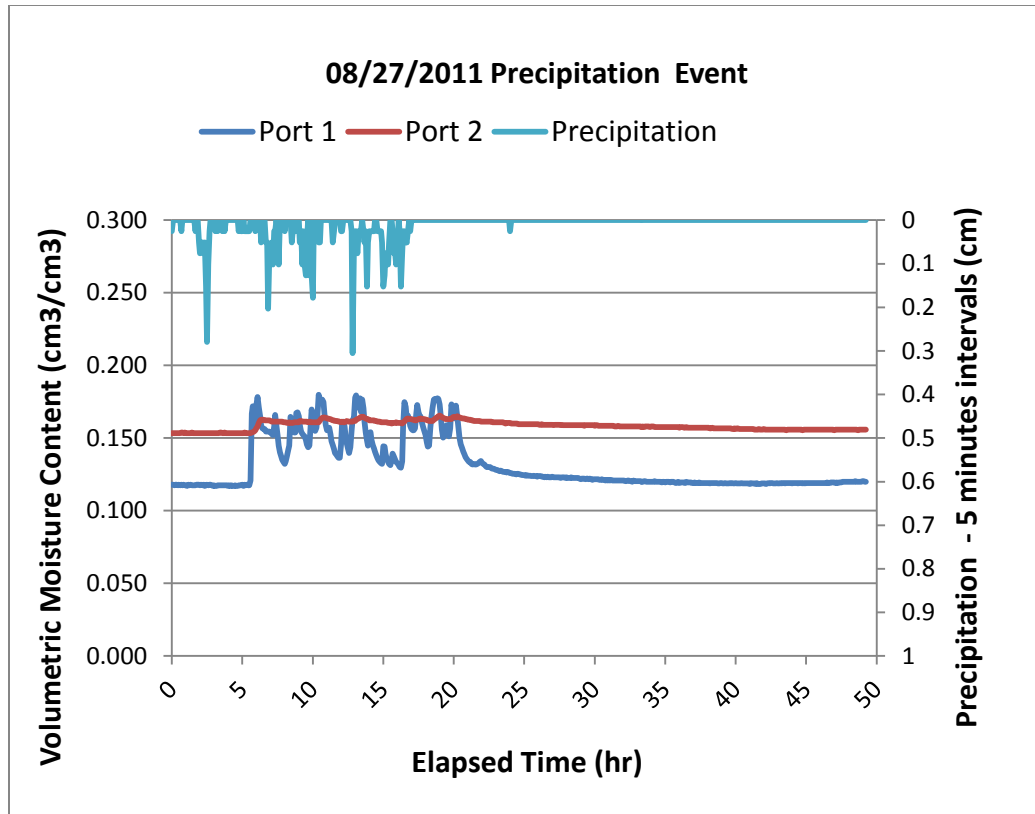

Figure 10 – The fluctuation of the VMC at the top (Port 1) and middle (Port 2) of the filter media during the most intense storm. Saturation occurs at 29% VMC. VMC data for probes 3 and 4 was not available for this precipitation event due to probe malfunctioning.

Table 6 – Average values of the initial, maximum and the change in the VMC during precipitation events

	Port 1	Port 2	Port3
Initial VMC (%)	11.1	13.0	9.2
Maximum VMC (%)	16.3	14.2	11.9
Change in VMC (%)	5.1	1.2	2.7

II.5 Conclusions

The main objective of this study was to investigate the nature of flow in PP systems in order to identify the most appropriate flow equations for modeling stormwater

routing through these systems. Special attention was given to the filter media, which is the most hydraulically restrictive material in the PP system, and which can control the flow through the entire system. The real time, continuous measurements of the VMC at four different levels in the PP system's sublayers showed that saturation did not occur at any level in the system over the period of study. In a similar monitoring study performed on bioretention systems, which typically are designed with a higher drainage area to filter media ratio (about 45:1), data showed that the bioretention soils did not reach saturation either (Carpenter, 2009). It appears that filtration stormwater management systems function predominantly under unsaturated conditions and consequently, unsaturated models such as Richard's Equation are more appropriate for hydrological simulation of these systems, rather than saturated flow equations such as Darcy's Law and Green-Ampt.

A disadvantage of representing the water flow through the filter media with saturated flow equations, as in current practice, is that the saturated hydraulic conductivity is much higher than the unsaturated hydraulic conductivity. Because of this, the saturated flow equations misrepresent the time to peak of the final system outflow hydrograph and the stormwater residence time in the system.

When PP systems are designed for extreme precipitation events or to receive runoff from adjacent impervious surfaces, the saturated flow modeling approach could lead to under sizing of the system with the result that the infiltrating water ponds above the filter media. Even when PP systems are designed based on unsaturated flow analysis, we recommend that proper consideration and design modifications are directed at sizing the storage provided above the filter media when the PP system is designed to receive run-

on. This is not a concern for PP systems designed to “treat” only the precipitation falling on the PP’s surface.

When PP systems are modeled as storage units, the incoming precipitation is placed immediately at the bottom of the system (Jackson and Ragan, 1974) and theoretically, saturation occurs as moisture is added and the water level rises from the bottom to the top. In reality, the moisture travels with a piston-like movement through the permeable media layers, and saturation (or just an increase in moisture content in our study) occurs from the top down. Even if supposedly the entire pore space is available for storage, the availability of the pore space is restricted by the actual advancement of the wetting front. Only the pore space behind the wetting front is used for storage, while the pore space ahead of the wetting front (the bottom of the system) is temporarily unavailable until the wetting front actually reaches that level. Considering the volume of the pore space in the PP systems, the studied system could theoretically hold more than 20 cm (7.9 inches) of water, which for the study site is close to the 100-year, 24-hour rainfall. However, an unsaturated flow analysis should be performed to evaluate the actual storage available under precipitation loads of interest.

Based on the information presented in this study, we recommend that modeling of flow through the filter media of PP systems and other LID-SWM systems should be performed with unsaturated flow rather than saturated flow equations. Incorporation of unsaturated functions in commonly used design software for PP systems would allow for better hydrological performance assessment, as well as optimization of the system’s configuration for site specific hydrological requirements.

CHAPTER III

Unsaturated flow functions for filter media used in Low Impact Development - Stormwater Management Systems

Abstract

Moisture retention relationships for coarse, high infiltration soils are difficult to empirically determine and estimate. Present day software models for stormwater management (SWM) that are used as sizing and performance prediction tools for filtration Low Impact Development – Stormwater Management (LID-SWM) systems typically assume that these systems function under saturated flow conditions. This directly impacts prediction of system drainage and hydrographs, as well as the estimates from physically-based water quality improvement. Yet real time monitoring of these systems demonstrated that saturation of the filter media is rarely achieved. This article presents a framework for obtaining the moisture retention curves (MRC) and relative hydraulic conductivity $K_r(\theta)$ function for engineered filter media and other hydraulic control soils used in four LID-SWM systems: pervious pavement, sand filter, gravel wetland, and bioretention system. These functions needed in routing water through the filter media with unsaturated flow functions are developed from easily measurable soil properties like porosity and particle size distribution, and can be integrated in current available stormwater design software. The framework consists of a sequence of physically based equations: Arya-Paris for the $\theta(\psi)$ function, Bower for gravel content adjustments along with an extension of the $\theta(\psi)$ function proposed in this article, and

Mualem for the $K_r(\theta)$ function. This sequence is combined with Van-Genuchten fitting equation for soils with irregular particle size distributions.

III.1 Introduction

Increasing environmental problems caused by polluted stormwater runoff from urban development led to modifications of the Clean Water Act. As a result, standards for the quality of stormwater runoff allowed to be discharged into receiving waters were improved with the result being strict qualitative and quantitative restrictions for the stormwater runoff that can be discharged off-sites or to receiving waters. To meet these criteria, stormwater management and treatment infrastructure had to evolve over the last few decades from conventional systems (swales, detention and retention ponds) which controlled the peak flow of the discharged hydrograph but were ineffective for most water quality parameters (USEPA, 2013), to more advanced treatment systems which, in addition to controlling the peak flows, target removal of both solids and dissolved pollutants and replicate natural hydrology. These new systems are known as Low Impact Development-Stormwater Management (LID-SWM) or Green Infrastructure. A few examples of LID systems include: pervious pavements, bioretention systems, tree filters, ecoroofs, subsurface gravel wetlands, sand filters, and other variations and combinations of these systems (USEPA, 2000). The main difference between conventional and LID systems is that the latter uses engineered filter media or other permeable media layers and customized hydraulic controls in order to: increase the residence time of stormwater in the system, remove pollutants by filtration and possibly biological processes, and allow increased evapotranspiration. In some situations, infiltration is also an integral component of these systems. The subsurface gravel wetland (GW), bioretention system (BS), surface

sand filter (SF), and pervious pavement (PP) are four different, yet similar stormwater treatment systems that incorporate a range of elements which are commonly found in other LID systems (UNHSC, 2009).

The BS, SF, and GW systems are represented by excavations, which are typically only partially backfilled with engineered soil layers. Above the surface of these systems there is surface storage capacity for the inflowing, untreated runoff. These systems are designed to allow ponding on top of the system during more extreme precipitation events. The engineered soil mixes in the BS and SF act as a filter media that remove pollutants and hydraulically control the stormwater flow through the system. They are placed on top of a crushed stone reservoir that can temporarily store the treated stormwater, and allow for an extended time for recharge to groundwater if appropriate. In some cases, rather than allowing the filter media to control flow through the system, the hydraulic control is in the piping after the filter media. This hydraulic control is via an orifice or other hydraulically restrictive element that requires water to back up before a significant flow rate leaving the system can occur. The configuration of the GW system is different than most filtration systems in that the primary flow path is through a saturated coarse gravel layer, and the overlaying lower conductivity soil's role is to support vegetation rather than filter pollutants or hydraulically control the system. The overlaying soil layer along with the outlet flow control is used to create an anaerobic zone in the GW which is prolific for microbial processes in the underlying stone reservoir. The GW coarse gravel reservoir is maintained saturated in between precipitation events, in comparison to the unsaturated filter media condition in between runoff events for the other three LID systems. In comparison to the SF, BS, and GW systems, PP systems do not provide

above-ground system storage. A typical PP system is represented by a layer of pervious asphalt, concrete, geogrid, or interlocking blocks on top of a layered sub-base. The sub-base structure provides both structural and hydrological functions, and the configuration varies depending on the loading capacity needs and site conditions. A typical configuration for the sublayers is: a layer of crushed stone, then a layer of bank-run gravel serving as the filter media, and another layer of crushed stone which acts as a reservoir for the treated water. Underdrains may be placed in the stone layer at the base of the system if drainage control is needed.

The soils used as filter media or hydraulic controls in LID systems vary in texture from just one soil textural class (a uniform sand in the case of the SF) to media that incorporates a wide range of textures (loam, sand, gravel, wood chips, and compost in the BS) (Claytor and Schueler, 1996; UNHSC 2009). Typically, if the system needs to sustain vegetation, organic soils are added to the mix. For non-vegetated systems (for example PP, SF), mineral soils such as bank-run gravel that need little engineering are used. Technical specifications for some filter media compositions are not very well established and recommendations vary within different stormwater governmental jurisdictions (Carpenter et al, 2010). Standardized soil mix specifications are developed in order to obtain more consistent infiltration rates for filtration systems and to ensure appropriate drain down times of the system in between precipitation events (UNHSC, 2012). In addition, research progress has been made in customizing soil mixes to target specific pollutants, such as metals and phosphorus (Stone, 2013). This creates the potential for an even higher variability in the textures of soils for stormwater LID systems.

In engineering practice, the configuration design and hydrologic assessment of SWM systems is performed with the aid of computer simulation tools (ie SWMM, WINSLAM, HydroCAD, StormCAD, etc). These software packages were initially developed for conventional stormwater systems that were relatively simple to represent mathematically, and they do not have the capabilities of simulating more complex flow routing through the permeable layers of LID systems (Elliot and Trowsdale, 2006). The simplified methodologies for modeling flow through these layers either assume that the flow occurs under saturated conditions, or treat the entire system as a storage unit where the available storage is the pore space in the soil matrix (Dussailant, 2003; Jayasuriya, 2008; Aad, 2010). Recent data collection at two PP sites revealed that saturation in the filter media is not achieved under natural precipitation events (Barbu and Ballestero, 2013a). A similar study performed on the filter media of bioretention systems (Carpenter, 2010), suggests that saturation does not always occur in the filter media of BS either, although these systems are designed to function under ponded conditions during large runoff events. This implies that the use of saturated flow equations like Darcy's Law or Green-Ampt are not always appropriate for modeling flow through the permeable layers of LID systems. Unsaturated flow equations (for example, Richards' Equation) would lead to more accurate hydrological design of LID-SWM systems.

III.1.1 Unsaturated flow functions

The most common equation used to describe saturated flow in pervious media is Darcy's Law (Darcy, 1856). Solving this equation requires knowledge of the saturated hydraulic conductivity (K_{sat}), and the hydraulic head:

$$q = -K_{sat} \left(\frac{dh}{dz} \right)$$

Equation 5

Where:

q = Darcian flow (L/T); K_{sat} = saturated hydraulic conductivity (L/T); dh = change in energy that drives the flow (L) across dz = the length of pervious media layer (L), z being the vertical direction.

Richards' Equation (Richards, 1931) is a non-linear partial differential equation that describes unsaturated flow conditions, and was derived by applying continuity to Darcy's Law. The moisture - based form of Richards' Equation is as follows:

$$\frac{\partial \theta}{\partial t} = \frac{\partial \left[D(\theta) \frac{\partial \theta}{\partial z} + K_r(\theta) \right]}{\partial z}$$

Equation 6

Where:

$\partial \theta$ = the change in volumetric moisture content (-); ∂t = the time interval for analysis (T);
 ∂z = the space interval/depth of layer (L); $\partial \psi$ = the change in matric potential (L⁻¹); $K_r(\theta)$
= hydraulic conductivity(L/T); and $D(\theta)$ = water diffusivity(L²/T);

Solving Equation 6 is more computing intensive and requires more input information than saturated flow equations. This requires information on unsaturated hydraulic conductivity (K_r), matric potential (ψ), diffusivity (D), and volumetric moisture content (θ). D , K_r and ψ are dependent on θ and therefore change with the change in moisture content. In order to solve Richard's Equation, the moisture retention curves

(MRC), also known as the $\theta(\psi)$ function, and the unsaturated hydraulic conductivity functions $K_r(\psi)$ need to be first defined. These relationships are unique for each soil; however, for a given soil they are highly nonlinear, non-unique, and difficult to accurately represent with a single function for the entire range of values. They can be generalized either through a continuous function or in tabular form.

III.1.2 The moisture retention curves: $\theta(\psi)$

The measurement of the $\theta(\psi)$ function can be expensive and time consuming (Dane and Topp, 2002). Measurements could require 12-16 weeks and even longer for finer particle soils such as clays. The alternative is to predict the $\theta(\psi)$ with mathematical functions. This makes $\theta(\psi)$ a function of other variables which are easier to measure, such as soil texture, porosity, or density. These functions are known as Pedotransfer Functions.

Common approaches for mathematically obtaining the $\theta(\psi)$ curves include: regression models from statistical regression analysis (Gupta and Larson, 1981; Rawls and Brakensiek, 1982; Vereken et al., 1992; Fredlund et al., 2002), functional regression methods (Brooks and Corey, 1964; Vereken, 1989; Van-Genuchten, 1982); and physicoempirical models (Arya-Paris, 1981; Haverkamp-Paralange, 1986).

Regression models relate the matric potential to the soil textural class, organic carbon content, porosity, and bulk density through regression analysis of measured data for multiple soils. These models do not consider the shape of the retention curves, therefore some functions derive J-shaped or S-shaped curves. The functional regression models also employ regression analysis, but they first make an assumption of the curve's shape, and then adjust it with fitting parameters. In order to use these models, the

measurement or approximation of parameters like K_{sat} and the air entry matric potential (ψ_b) are needed. One disadvantage of these two types of models is that they were developed with statistical regression analysis taking into account several soil samples, and therefore cannot be fine-tuned or easily manipulated for engineered filter media. The fitting parameters in these models were developed for the major soil textural classes (clay, loam, silt, and sand) and not for coarse engineered soils like those used in LID-SWM systems.

The physicoempirical models (Arya-Paris, 1981; Haverkamp-Parlange, 1986) are based on the observation that the cumulative particle size distributions (PSD) and the $\theta(\psi)$ curves are very similar in shape. This implies that the pores-size distribution of the soil matrix, and therefore its water retention capacity, can be computed from PSD data and the degree of soil compaction. This hypothesis of shape similarity was confirmed later in 1998 by analyzing 660 soils from the GRIZZLY database (Haverkamp et al., 1998). While physicoempirical models rely on some parameter estimation to transition from an ideal pore to the natural pore characteristics corresponding to soil fractions, it is the most physically-based model developed for derivation of the $\theta(\psi)$ relationship, and allows for a more detailed representation of the soils' texture. Though both Arya-Paris and Haverkamp-Parlange have minimal input data requirements, Arya-Paris is especially preferred in practice as it is valid for more soil types, while the later model is valid only for pure sands with no organic matter (Dane and Topp, 2002).

III.1.3 The unsaturated hydraulic conductivity curves: $K_r(\theta)$

Unlike the $\theta(\psi)$ curve, the $K_r(\theta)$ or $K_r(\psi)$ curves are very difficult to measure, and even when performed, may have large errors (Dane and Topp, 2002). In practice, the K_r

curves are commonly derived with a selection of methods when the $\theta(\psi)$ curve is known: Baver et al, 1972; Childs and Collis-George, 1950; Burdine, 1953, Gardner, 1958; Marshall and Holmes, 1979; Brooks and Corey, 1966; Mualem, 1976, or Van Genuchten, 1980. Most of these mathematical models predict K_r based on the capillary tube theory which states that the pores are filled progressively from the smallest to the largest ones up to the point of saturation, and that the larger pores empty first. Mualem's model (Mualem, 1976) (Equation 7-8) is the most widely used model to predict the $K_r(\psi)$ function. The input data required for this model consists of the value of K_{sat} and the $\theta(\psi)$ function for a specific soil. If the $K_r(\psi)$ and $\theta(\psi)$ functions are known, $K_r(\theta)$ can be easily obtained.

$$Kr(\theta) = Se^n \left[\frac{\int_0^\theta \frac{d\theta}{\psi}}{\int_0^{\theta_{sat}} \frac{d\theta}{\psi}} \right]^2$$

Equation 7

$$Se = \frac{\theta - \theta_r}{\theta_s - \theta_r} \quad 0 \leq Se \leq 1$$

Equation 8

Where: θ_r = residual water content (L^3L^{-3}); θ_{sat} = water content at saturation (L^3L^{-3}); θ = actual water content (L^3L^{-3}); and Se = effective saturation (-).

The need for more detailed representation of the soil infiltration processes in LID systems is well recognized (Braga et al. 2007; Dussailant et al. 2004), but the intensive data input required for solving unsaturated functions is a hurdle for stormwater engineers

in using Richard's Equation. For this reason, saturated models are still preferred in practice for modeling LID systems. We believe that the development of predictive methods for MRCs and K_r functions, which require input data that is more accessible to designing engineers, would increase the likelihood that unsaturated flow modeling capabilities would be incorporated into SWM simulation software used for designing LID systems. In doing so, the design of these systems is more accurate. The development of a specifically adapted framework for obtaining the MRCs for soils used for flow control in LID-SWM systems from soil properties is further explored.

III.1.4 Applicability of traditional MRC models to SWM filter media

The challenge of obtaining the MRCs for SWM filter media with the previously cited models derives from the fact that filter media consists of disturbed and repacked engineered soils that contain appreciable amounts of particles larger than 2 millimeters and/or wood chips, while the traditional models were developed for agricultural and forest soils, based on undisturbed samples at field compaction. All reviewed models are valid for soils containing particles up to 2 millimeters. Because the ties of the methods to agricultural soil analyses, the prediction range of these models focuses on the dryer end of the MRC, as field capacity and wilting points were important concepts for crop management. In filter media design for stormwater treatment, fine particle content is limited in order to maintain appropriate drain-down of the system in between precipitation events and to minimize frost impacts in the cold seasons (Roseen et al, 2012). Therefore, the range of interest in employing these MRC and K_r models shifts to the wetter range of the MRC when evaluating LID-SWM filter media. This is where the coarser soil particles play an important role in the development of MRC's.

While gravel particles absorb a negligible amount of water and act as a dead volume in terms of water conductivity (Bouwer, 1984; Kahaleel and Relyea, 1997), dry wood chips can absorb considerable amounts of water at the beginning of the storm and retain it until the water around them is drained. Therefore, wood chips behave in a similar way to gravel when wet, as they contribute very little to water transport while there is still moisture in the soil around them, but behave as a sponge when dry. These factors are important when evaluating the MRCs for engineered filter media.

The most suitable models for LID-SWM filter media as they relate to fluid movement through the systems seem to be the physicoempirical models as they use for input the PSD, density, and porosity of a soil to derive the $\theta(\psi)$ relationships. These are the most common parameters that are reported when describing engineered soils and the most accessible data to practicing engineers. In addition, physicoempirical models generate data points for the entire range of moisture contents as opposed to other models that do not cover the wetter range. With the wide range of textural classes used in filter media for stormwater treatment (Figure 11), it would be useful for engineers to be able to derive the MRC's from easily measurable data for their specific soils instead of analyzing each soil mix in the laboratory.

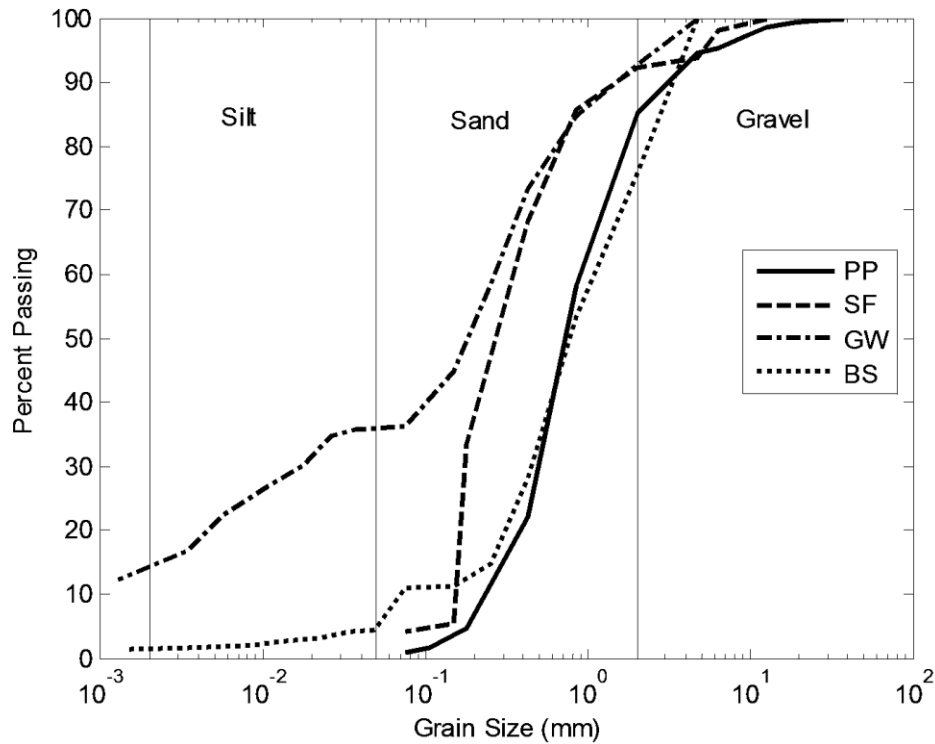

Figure 11 – Particle size distributions for the filter media in the PP, SF, GW and BS systems.

The effectiveness of using a series of available equations to derive the MRCs for typical LID-SWM filter media was tested: the Arya-Paris (A-P) model (Arya and Paris, 1981; Arya et al. 1999) was used to generate $\theta - \psi$ data points for the fine fraction of filter media soils; adjustments for large particles were made with the Bouwer Equation (Bouwer and Rice, 1984); spline interpolation (Arya et al. 1999) and Van-Genuchten (VG) Equation (Van Genuchten, 1980) were used to obtain the continuous $\theta(\psi)$ curve; and the $K_r(\theta)$ curve was generated with Mualem's Equation (Mualem, 1976). The performance of this sequence of equations to predict the MRCs for the original/bulk soil

was tested against laboratory measurements for four engineered soils used in actual SWM systems: PP, GW, BS and SF.

III.2 Materials and Methods

III.2.1 Particle size distributions

Soil samples used for the filter media in the four LID systems were gathered from the stockpiles used to build the actual systems and the PSD were developed conforming to ASTM D422-63, using standard engineering sieve sizes: # 4, 10, 20, 40, 60, 100 and 200 (Figure 11). Since the GW and BS samples contained a significant amount of fine particles, hydrometer tests were performed for the fraction that passed the # 200 sieve for these samples. The GW soil displayed significant aggregation, which made the PSD look more like a sandy-gravel after dry-sieve analysis. A wet-sieving analysis was performed for this soil in order to break down all the clusters of aggregated clay. Since the BS sample contained finer particle soils, wood chips, and organic matter, a sequence of dry-sieving, wet-sieving, and wood chips combustion were performed on this sample. PSDs were recorded after each step of the analysis on the BS mix as presented in Figure 19. The PSD obtained after combustion of the wood chips was used with the A-P model for this soil.

III.2.2 Arya – Paris Model

The final PSDs for the four soils (Figure 11) were used with the A-P model to develop a series of $\theta - \psi$ data points, following the detailed procedure presented in the Methods of Soil Analyses (Dane and Topp, 2002). The A-P model starts with the PSD

curve which is divided into soil fractions. A cubic closed-pack structure was assumed for uniform size particles, with a radius (R_i) equal to the average particle size for that fraction. Knowing the density of the particles (ρ_s), bulk density (ρ_b) and the void ratio (e), the number of soil particles (n_i) and the pore radius (r_i) was computed for each fraction. The pore space for each fraction was then successively summed to yield the total pore space in an ideal soil matrix with spherical particles. The total pore space represents the maximum moisture content that the soil can hold if the pore space is filled with water. To account for the non-uniform particle shapes and randomness of packing in a natural soil matrix, a scaling parameter (α) is computed for each soil fraction and applied to the pore radii.

The scaling parameter α was computed with the similarity method (Arya et al., 1999), using the sand values for a and b for the PP and SF samples, and loam values for GW and BS samples (Table 8). These values were selected based on the predominant soil fraction of each filter media soil:

$$\alpha_i = \log N_i / \log n_i$$

Equation 9

$$\log N_i = a + b \log(W_i / R_i^3)$$

Equation 10

Where: α_i = scaling parameter (-); R_i = average particle radius for soil fraction i , computed as the average radius of the upper and lower limits of the soil fraction i (L); N_i = the equivalent number of particles of radius R_i needed to trace the actual pore length (-);

n_i = the number of spherical particles in the fraction i (-); W_i = the fraction of solid mass (-); a, b = parameters for relating $\log(N_i)$ to $\log(W_i/R_i^3)$ (-);

Once corrected, the pore radii were converted to the matric potential corresponding to each fraction with the capillary equation:

$$h_i = \frac{2 \gamma (\cos\theta)}{\rho_w g r_i}$$

Equation 11

Where: h_i = capillary pressure head corresponding to fraction i (L); γ = air - water surface tension (MT^{-2}); θ = contact angle (degrees); ρ_w = the density of water (ML^{-3}); g = acceleration due to gravity (LT^{-2}); and r_i = pore radius for fraction i (L).

Since the pore space is equivalent to the moisture content that each soil fraction can hold, each pressure head – pore volume data point generated with the A-P model for each soil fraction used in the PSD curve represent one pair of $\theta - \psi$ values. The final number of data points corresponds to the number of soil fractions that were used to divide the initial PSD used in A-P model. Initially, the soil fractions used with A-P model were those corresponding to the standard engineering sieves that are commonly used in engineering practice. Additional runs were performed with the soil fraction intervals recommended by A-P.

In addition to the PSD, the A-P model requires knowledge of bulk density and the porosity of the soil. The bulk density was measured in the laboratory according to ASTM D7263 and porosity was computed with Vukovic Equation (Vukovic and Soro, 1992).

$$Porosity = 0.255 (1 + 0.83^\eta)$$

Equation 12

Where: η = the coefficient of uniformity of the soil (-) = D60/D10.

III.2.3 Correction for coarse particles

Since A-P is valid only for particles up to 2mm, the model was applied to the fine fraction of the soils which was normalized to 100%. In practice, mass- or volume-based equations (Peck and Watson, 1979; Brankensiek, 1986; Bouwer, 1984; Saxton and Rawls, 2006) are used to correct for the space occupied in the soil matrix by the gravel particles which do not contribute to water transport. The Bouwer Equation (Bouwer, 1984) was successfully used in similar studies to correct for gravel content (Bagarello and Iovino, 2007; Gribb et al, 2009), and was used for gravel adjustment for this application:

$$\theta_{bulk} = \theta_{fine} (1 - V_{gravel})$$

Equation 13

Where: θ_{bulk} = moisture content for the bulk soil (-); θ_{fine} = moisture content for the fine fraction of the soil (-); and V_{gravel} = volume fraction of gravel (-).

One shortcoming of this approach is that it does not account for the macropore formation due to coarser particles (Saxton and Rawls, 2006), which correspond to the saturation end of the $\theta(\psi)$ curve. The Bouwer Equation, or any of the other commonly used equations for this matter, (Peck and Watson, 1979; Brankensiek, 1986; Bouwer, 1984; Saxton and Rawls, 2006), adjusts the moisture content corresponding to each matric potential computed with A-P by subtracting the volume occupied by gravel

particles from the total pore space, but it does not extend the curve at the saturation end (Figure 12).

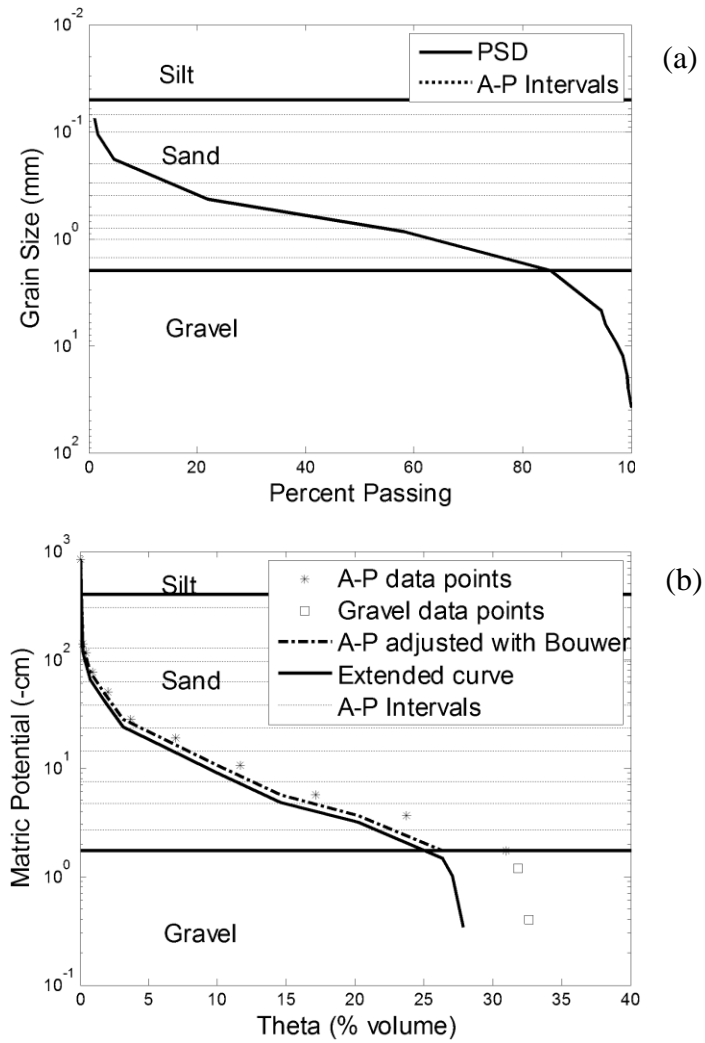

Figure 12 – Similarity principle: transition from a particle size distribution (a) to a moisture retention curve (b), adjustments for gravel content with Bouwer Equation (b), and extension of the MRC beyond Arya-Paris applicability range (b).

III.2.4 Curve fitting

The A-P model only generates paired data points of the moisture content and their corresponding matric potential. In order to obtain a continuous $\theta(\psi)$ curve, the A-P generated data points were connected with spline interpolation as in the original A-P model (Arya and Paris, 1981). A second approach for obtaining the complete $\theta - \psi$ curve was to fit the Van-Genuchten (VG) Equation (Van Genuchten, 1980) to the A-P generated data points. The VG Equation curve fitting was performed with the RETC program (Van Genuchten et al, 1991), which is public domain software.

$$\theta(\varphi) = \theta_r + \frac{\theta_s - \theta_r}{[1 + (\alpha * \varphi^n)]^{1-1/n}}$$

Equation 14

Where: $\theta(\psi)$ = moisture retention curve [L^3L^{-3}]; ψ = matric potential [L^{-1}]; θ_r = residual water content (L^3L^{-3}); θ_s = saturated water content (L^3L^{-3}); α = scaling parameter for the matric potential (L^{-1}); n = parameter that describes the pore size distribution (-).

The $\theta - \psi$ curves obtained this way were used in conjunction with Equation 7 to develop the second function needed to solve Richard's Equation: the $K_r(\theta)$ function.

III.2.5 Testing data

For testing purposes, the $\theta - \psi$ data points were measured in the laboratory on the initial wetting curves for each of the four filter media soils. A total of twelve data points were measured over the entire range of the $\theta(\psi)$ curves, with the following apparatus: hanging column (ASTM D2434), pressure plate (ASTM D6836), dew point potentiometer (ASTM D 6836), and relative humidity box (Karathensis and Hajeck, 1982).

Saturated hydraulic conductivity (K_{sat}) was measured with the constant head-rigid wall method (ASTM D2434). The continuous $\theta(\psi)$ curve was fitted with Van Genuchten and the $K_r(\theta)$ curve was derived with Mualem's Equation using the RETC code. Porosity at field compaction was also measured in the lab (ASTM D7263) and compared with the values computed with Vukovic Equation.

III.3 Results and Discussions

Engineered filter media tend to have more irregular PSD shapes than natural soils, as some soil fractions are left out for structural reasons. The percent of fines in SF and PP filter media for example is limited to 6% (UNHSC, 2009b) in order to avoid clogging of the media and allow for a quick drain down of the system. The BS mixes typically contain the most varied texture of soil and wood chips (which can be either shredded or chipped), but they do miss some intermediate particle sizes and this causes the PSD to have an irregular shape. Since the A-P model is based on the similarity principle, which states that the shape of the MRC is similar with that of the PSD curve, the irregularities in the PSD curves were carried over in the MRCs shape as well. In the original model (Arya and Paris, 1981), Arya obtained a continuous $\theta(\psi)$ curve by connecting the generated $\theta-\psi$ data points with spline interpolation. When interpolation was applied for the four filter media types, the irregular shape was more prominent in the BS, SF and GW soils and especially at the finer end of the PSD where certain soil fractions were missing (Figure 13 - 16). The PSD for the PP sample was a very smooth curve and the interpolation of the A-P generated data points for this sample resulted in a smooth curve as well (Figure 13).

In reality, the matric potential decreases as the moisture content increases so the $\theta(\psi)$ relationship should be described by a smooth curve. However, for the BS, SF, and GW samples, the interpolated curve displayed irregularities in the sections where corresponding soil fractions were missing from the PSD. These irregularities in the $\theta(\psi)$ shape would lead to computational errors when used to solve Richard's Equation. In practice, when $\theta - \psi$ data points are measured in the laboratory, the continuous $\theta(\psi)$ function is obtained by fitting the VG Equation to the measured data. Therefore, a second curve was fitted to the A-P generated data points using this method, with the fitting parameters presented in Table 7.

Table 7 – Van Genuchten fitting parameters

System	θ_r (%)	θ_{sat} (%)	VG – α (-)	n (-)	l (-)	Ksat (cm/min)
PP	4.5	29.70	0.145	2.68	0.5	4.14
SF	4.5	34.56	0.145	2.68	0.5	0.78
GW	4.5	44.00	2.146	1.34	0.5	1.56
BS	4.5	39.15	0.950	1.22	0.5	0.05

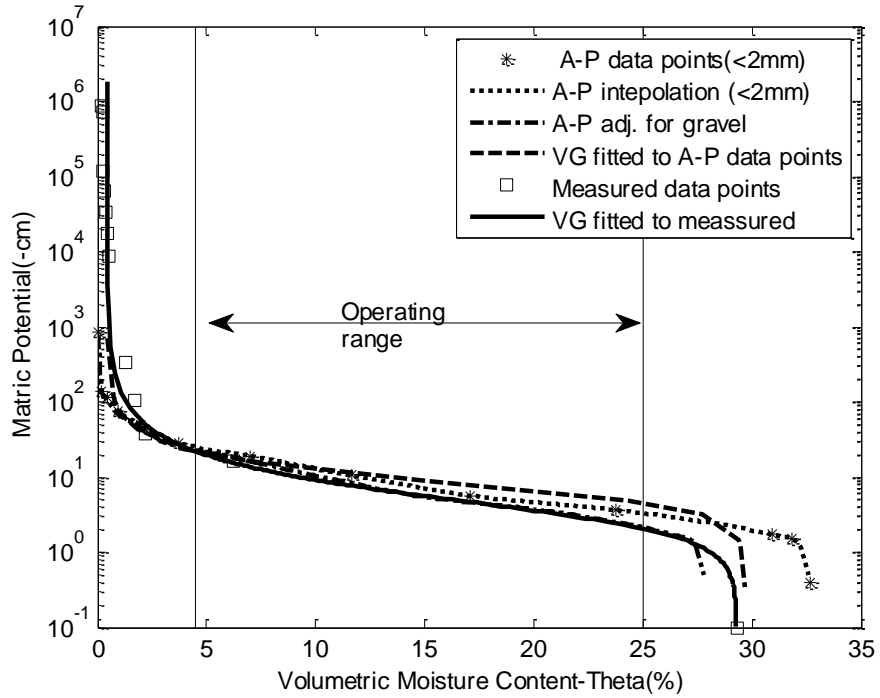

Figure 13 – The volumetric moisture content with respect to the matric potential for the PP filter media.

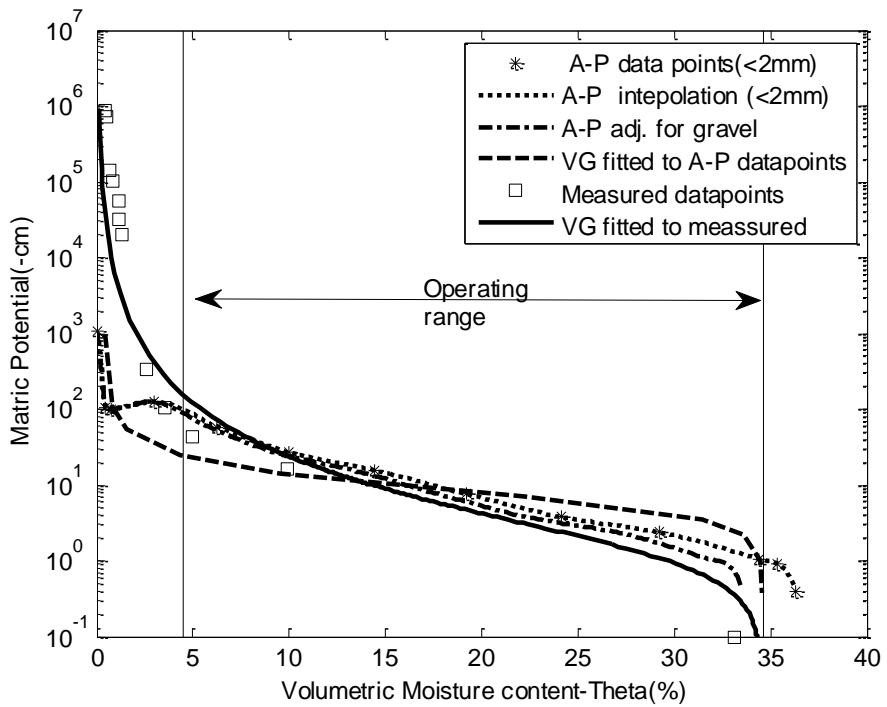

Figure 14 – The volumetric moisture content with respect to the matric potential for the SF filter media.

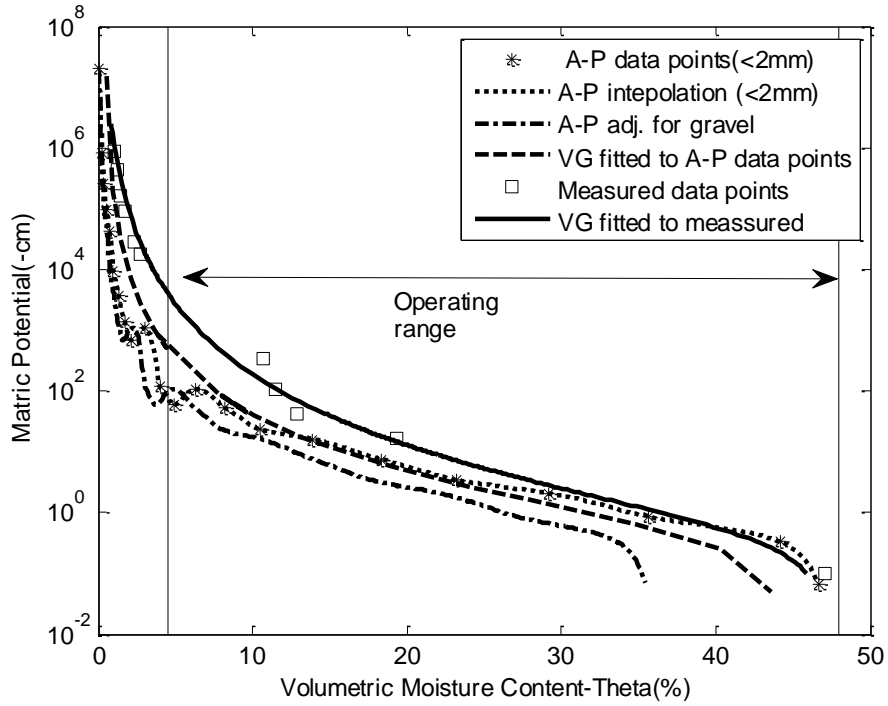

Figure 15 – The volumetric moisture content with respect to the matrix potential for the GW filter media.

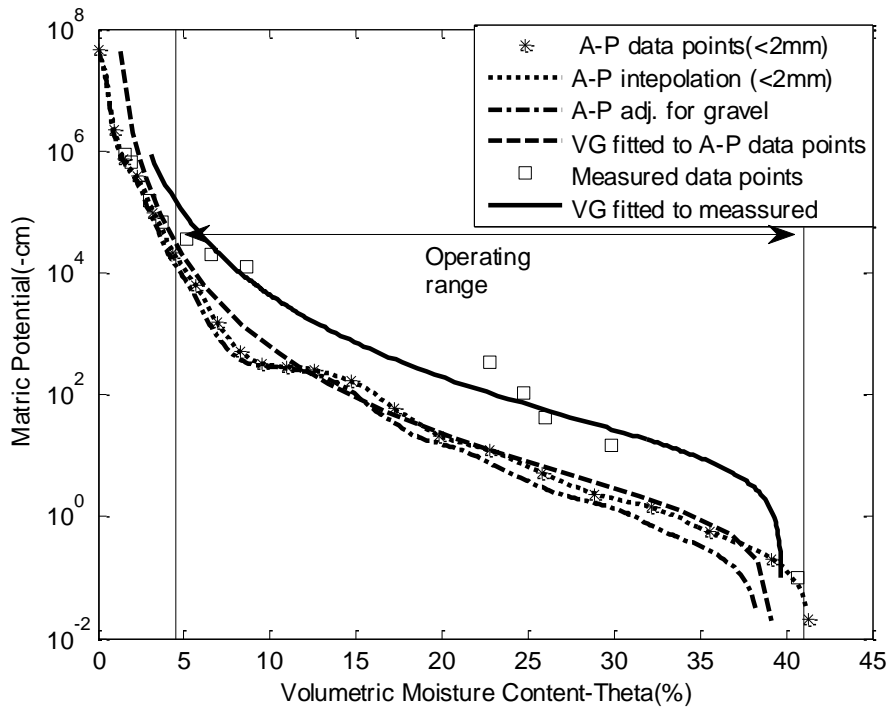

Figure 16 – The volumetric moisture content with respect to the matrix potential for the BS filter media.

The comparison of the measured and A-P generated data points along with the spline interpolation and VG fitted curves for the four filter media types are presented in Figure 13 - 16. Accurate measurements in the wetter range of the $\theta(\psi)$ curve are difficult to obtain in the laboratory due to quick loss of water from the soil samples when the moisture is close to saturation. The measured data points are clustered mostly on the drier range of the curve, while the computed data points are more evenly distributed along the curve. For this reason, the comparison of the fitted curves is more relevant than comparison of the actual $\theta - \psi$ data points. The interpolated and VG fitted curves to the modeled $\theta - \psi$ data points were compared through statistical analyses to the VG curve fitted to the observed data for the operation range of each system (Table 8). While both interpolated and VG fitted curves had high coefficients of determination for most samples, the VG fitted curves are recommended when the PSD and its corresponding A-P generated $\theta(\psi)$ curves displays irregularities; this could potentially lead to computational problems when used with unsaturated flow equations.

Table 8 – The goodness of fit of the interpolated and Van Genuchten curves to the measured data: the coefficient of determination (r^2) and root mean square error (RMSE).

System	r^2 – Interpolated	r^2 – VG	RMSE- interpolated (cm)	RMSE- VG (cm)
PP	0.982	0.981	0.053	0.136
SF	0.959	0.761	0.348	0.804
GW	0.995	0.995	149.79	131.01
BS	0.583	0.982	17.53	15.41

Real time volumetric moisture content data collected for over one year in a PP system installed at the University of New Hampshire revealed that θ recorded at three different vertical locations within a 30 cm (12”) filter media layer ranged between 4.3%

and 20.2%. Since the filter media had a porosity of 34.4% and θ_{sat} of 29.3%, this implies that the filter media never achieved saturation under normal and even extreme precipitation which occurred over the monitoring period. Typical real time variation of the moisture content observed in the filter media of this system is presented in Figure 17.

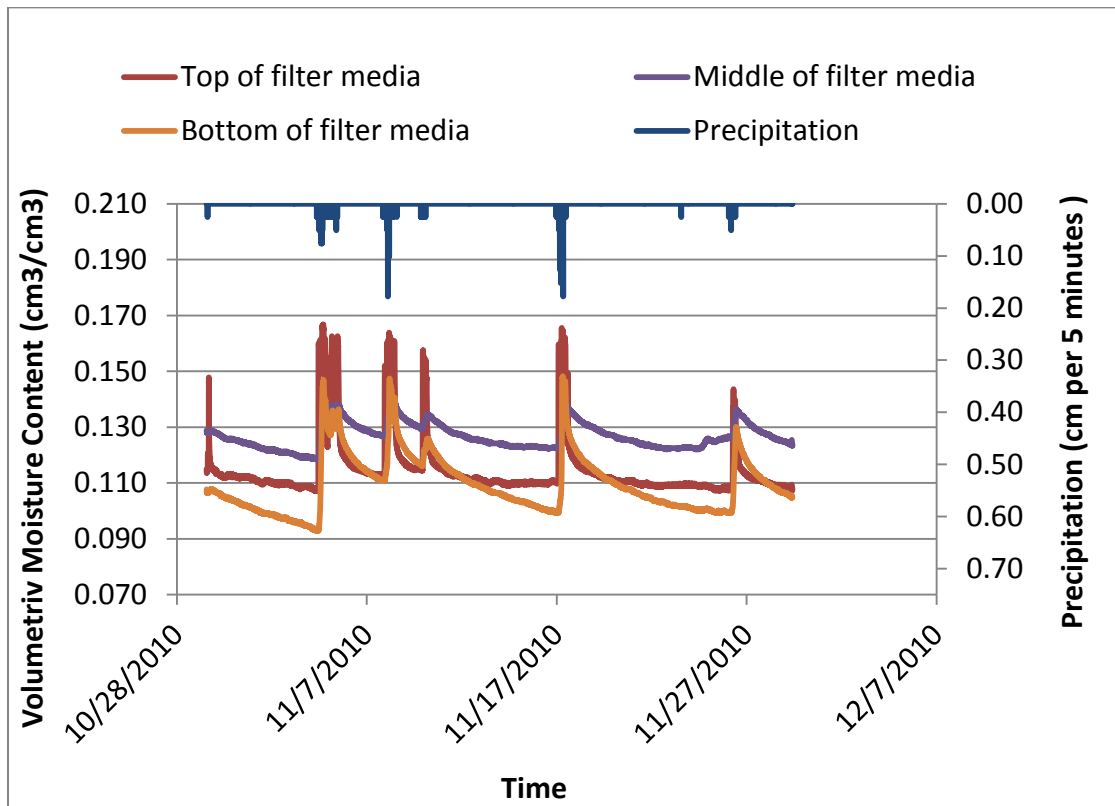

Figure 17 – The fluctuation of the volumetric moisture content (θ) measured at three levels within the filter media of a pervious pavement system under natural precipitation

The accuracy of the proposed sequence of equations for generating the $\theta(\psi)$ curve for the PP filter media was evaluated over a conservative moisture content operating range of 4.5% to 25%. This was based on observations of soil moisture profiles in the filter media of a PP system for over one year (Barbu and Ballesterro, 2013a). The other three systems (GW, SF, BS) are designed to function under ponded conditions during

larger design storms, and are likely to reach saturation several times a year, at least at the media surface where water is ponded. The operating range for which these three systems were evaluated was from residual moisture content (θ_r) to saturation moisture content (θ_{sat}). Similarly to the PP sample, the values for θ_r were selected at 4.5% for all three filter media, and θ_{sat} was based on laboratory measurements: 34% for the SF, 41% for the GW and 48% for the BS. The measured and model derived $\theta - \psi$ data points, along with the fitted curves for the four filter media soils are presented in Figure 13 - 16.

Based on the coefficient of determination (r^2) and root mean square error values (RMSE) presented in Table 8, the sequence of equations proposed in this study performed especially well for the mineral soils used as filter media in the PP and SF (Figures 13 -14), but they underestimated the matric potentials for the GW and BS filter media that contained finer particles (Figure 15 - 16), especially at the low moisture content end of the curve. The RMSE were improved for these two soils if the fit was analyzed starting at a higher moisture content than 4.5%. Given that the finer particle soils are more hysteretic than coarser soils (Gallage and Uchimura, 2010), and that the laboratory measurements were taken on the wetting curve which has higher matric potential than the drying curve at the same moisture contents, the predicted curves are within the generally acceptable range of prediction. It is also important to consider that the test data for the statistical analyses is assumed to be error free, which is not necessarily true. The “observed” curves used to test for the accuracy of “predicted” curves were actually an estimated fit of VG Equation to measured $\theta - \psi$ data points.

III.3.1 The K_r function

The $K_r(\theta)$ curves developed with Mualem's model applied to the VG curve fitted to the measured and computed $\theta - \psi$ data points for the PP filter media were compared in Figure 18. Given that both data point series were fitted with VG, the shape of the two curves is very similar and that might be the reason for very good r^2 and RMSE values of 1.00, and 0.003 respectively, when evaluated for the operating range of moisture contents from 4.5 to 25%.

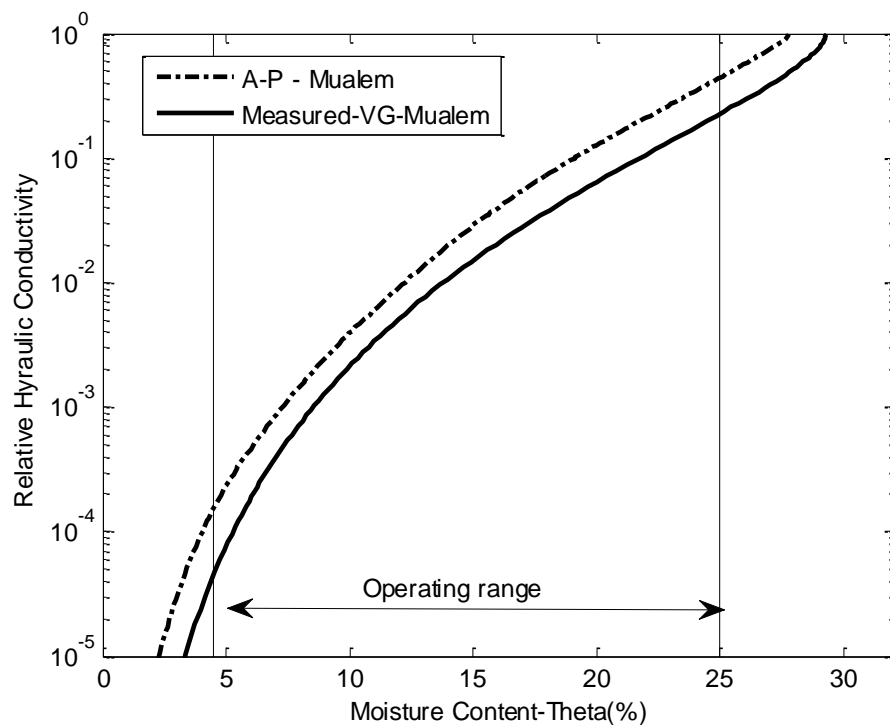

Figure 18 – Unsaturated hydraulic conductivity developed with Mualem's Equation as applied to the measured and computed volumetric moisture content – matric potential curves.

III.3.2 Gravel content compensation

Whether measured in the laboratory or developed with mathematical models, the $\theta - \psi$ data is customarily evaluated for the fine fraction of the soils, rather than bulk samples. There is some disagreement in the literature on whether the gravel adjustment of the measured data is necessary or not when developing the unsaturated functions for soils containing coarse particles (Khaleel and Relyea, 1997; Sauer and Logsdon, 2002). Other studies (Milczarek et al, 2006) found that the coarse particles can affect the hydrological properties of soils differently, depending on the ratio of the coarse particles to fine particles. Milczarek et al.(2006) found that there is a threshold of approximately 30% gravel content above which the gravel particles contributes to macropore formation and therefore increases the fluid transmission capacity of the soil matrix, while below this threshold, the finer particles become predominant in the soil matrix and fill the spaces between the gravel particles. In this case coarse particles act as a dead volume that increases the pore tortuosity and impede water transmission.

For the four filter media types, the gravel content ranged from 7.2 to 24% (Table 10), all below the 30% threshold. In this study, the $\theta(\psi)$ curves adjusted for gravel were in better agreement with the measured curves than the unadjusted curves. However, compensation only with the Bouwer Equation did not adequately represent the air entry section of the curve. This section of the curve is generally described by a steep increase in the matric potential with a small decrease in moisture content, as the air enters the larger pores when the soil begins to desaturate. This concept was not evident when adjustments were made only with the Bouwer Equation (Figure 12). Bouwer's assumption was that gravel particles do not contribute to fluid transport. He suggested

adjustment of the moisture content corresponding to each matric potential by subtracting the volume occupied by gravel particles from the total pore space. This approach only shifts the curve to the left (Figure 12), but does not extend it to the saturation end where the gravel particles are contributing to the macropore formation. With this approach, the largest alteration of the curve takes place at the saturation end, and decreases proportionally with the pore space towards the drier end of the curve. For this reason, correction for gravel content becomes especially important at the saturation end. In order to account for the macropore formation, the A-P generated $\theta - \psi$ data points were extended to the saturation end by adding data points corresponding to the soil fraction greater than 2mm which were outside the prediction range of the A-P model and were initially excluded from the PSD. To follow the same principle as in the A-P model, where each soil fraction generates a pair of $\theta - \psi$ points, two more data points were added initially for the fine gravel and coarse gravel soil fractions. Similarly as in the A-P model, the matric potential was represented by the capillary rise for each soil fraction, and the corresponding moisture contents were the volume of the pore space of that fraction. The capillary rise in fine and coarse gravel is typically in the range of 2 to 10 cm, and 0.5 to 2 cm, respectively (Lane and Washburn, 1946). The pore space occupied at saturation is generally in the range of 0.9 to 0.95% of the total porosity (Van Genuchten et al, 1991). Based on this information, the extension data points were initially set at matric potentials of -3.5 and -1 cm, and moisture content of 0.925 and 0.95% of the soil porosity, respectively. In order to account for the natural pore space and intermixing of different particle sizes, these values were then calibrated for each filter media type (Table 9), with measured data (Table 10). For the PP and SF samples which are coarser and have fewer

finer, two data points were needed to represent the saturation end of the curve, while for the GW and BS samples which have a larger amount of fine particles, only one extension data point was needed to meet the A-P generated data points.

Table 9 – Extended $\theta - \psi$ data points for the fine and coarse gravel soil fractions

System	θ_1	ψ_1	θ_2	ψ_2
	0.925*Porosity (%)	(cm)	0.95*Porosity (%)	(cm)
PP	31.82	1.5	32.68	0.4
SF	35.33	1.5	36.29	0.4
BS	N/A	N/A	41.33	1.2
GW	N/A	N/A	46.65	1.2

Table 10 – Soil properties for the four types of filter media

System	Gravel Content (%)	Porosity Measured (%)	Porosity Computed (%)	θ_{sat} (%)	Ksat (cm/min)
PP	14.8	34.4	33.97	29.3	4.14
SF	7.6	38.4	38.23	33.1	0.78
BS	24	49.1	23.43	47.1	1.56
GW	7.2	43.5	N/A	40.7	0.05

The combination of Bouwer Equation with the extension of the curve to saturation were in close agreement to the measured curves for the PP, SF and GW samples (Figure 13 - 15), but seemed to overcompensate for the coarse particles in the BS filter media (Figure 16). One thing that differentiates the BS soil from the other three samples is that it contains wood chips. Initially, the wood chips were considered in the A-P model as solids, and only the bulk density of the soil was changed to reflect the light weight of the soil mix. Since the PSD curves are typically developed on a weight basis, the dry wood chips content (approximately 10% by volume) contributes very little to the total mass of

the sample and is almost invisible in the PSD (Figure 19) which serves as input for the A-P model. In addition, the A-P model is developed for the fine fraction only and the wood chips are in the coarse particle fraction of the soil. If the wood chips were to be wet while performing the PSD analysis, as they would be at field condition, then the weight of the coarse fraction would be higher. Therefore, wood chips could be considered to behave in a similar way to gravel particles, as they initially absorb water but do not contribute to the moisture flux during precipitation events while there is still moisture in the pore space. However, wet wood chips increase the overall moisture content of the soil, and cause the θ values to be higher than for the soil without wood chips for the same matric potentials. We suggest that the adjustment of the $\theta(\psi)$ curve for wood chips content may be performed in a similar way to the gravel adjustments, though corrections for wood chips would shift the curve in the opposite way from that of gravel corrections. Based on the assumption that wood chips would offset the gravel particle effect on the MRC, when the volume of gravel and wood chips present in the soil is approximately the same, the gravel adjustment would not be necessary. If the volumes are different, the adjustment would be done proportionally on volumetric bases. The overcompensation for the BS soil at the saturation end was approximately 12%, while the wood chips content was 10%. The concept for wood chips content adjustment on the $\theta(\psi)$ curve seems to hold true for the BS soil in this study, although further investigation and testing of this theory is warranted.

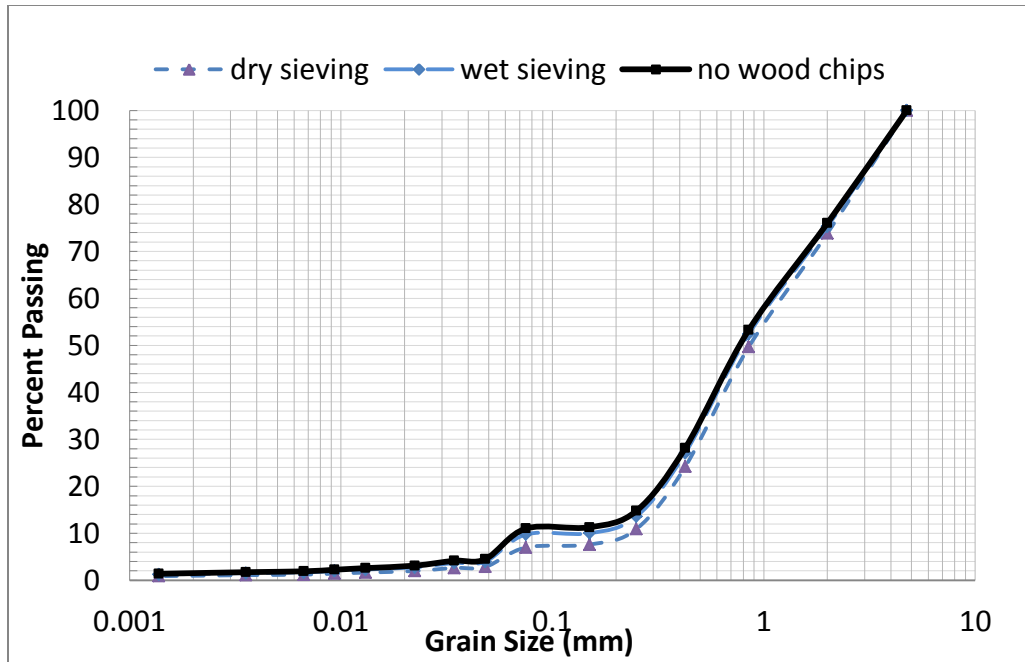

Figure 19 – The particle size distribution for the BS filter media, developed after dry- and wet-sieving, and combustion of wood chips.

III.3.3 A-P Model sensitivity with respect to number of intervals and α computation

The number of soil fractions for the PSD division recommended by Arya was set to twenty (Dane and Topp, 2002), but it is known that the A-P model is sensitive to the number of intervals used to subdivide the PSD. The $\theta(\psi)$ curve sensitivity to the number of intervals was analyzed in order to understand whether a different number of fractions would yield a better fit to measured data for coarser engineered soils. For this analysis, the number of intervals selected initially was that corresponding to the soil fractions obtained with standard engineering sieves. Then a series of analyses were performed with logarithmically, evenly distributed intervals of the PSD curve (Figure 20), varying from 8 to 40 intervals. Special attention was given to the range of values for the scaling parameter α . The typical range for α is between 0.95 and 2.5 (Arya et al., 1999), but

values even higher were reported for coarse soil fractions (Dane and Topp, 2002). We concluded that the best fit for the measured data for these soils was developed with twenty soil intervals, as recommended by Arya-Paris. A smaller number of intervals resulted in a narrow range of α values, clustered at the upper end of the normal range (1.343 to 1.399), while an increased number of intervals caused α to become very small and even negative (Table 11). When the original soil fractions were used for the four filter media soils, α was within the expected range of values (Table 12).

Table 11 – Arya-Paris model sensitivity analysis with respect to the number of intervals

Number of intervals	α range
8	1.343 – 1.379
13	1.287 – 1.373
20	1.115 – 1.364
26	0.887 – 1.362
30	0.254 – 1.361
40	-0.350 – 1.361

Table 12 – Arya-Paris model scaling parameters

System	A-P fitting parameters		
	a	b	α range
PP	-2.478	1.49	1.0194 - 1.3200
SF	-2.478	1.49	0.7290 - 1.3345
BS	-3.398	1.773	0.9615 - 1.6313
GW	-3.398	1.773	0.6301 - 1.6415

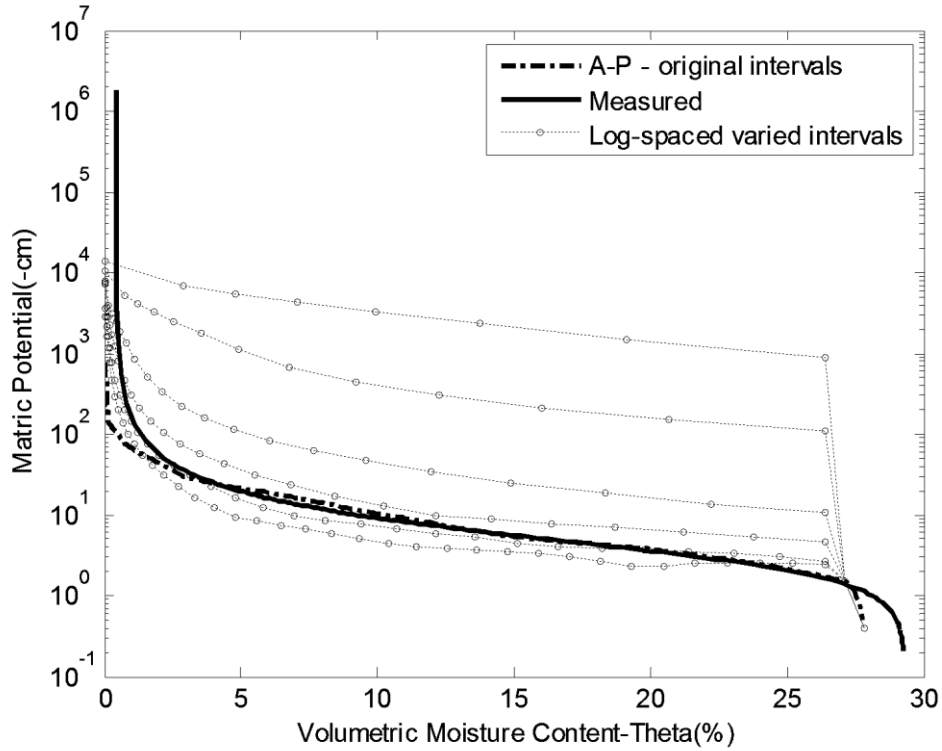

Figure 20 – The sensitivity analysis of the Arya-Paris model with respect to the number of intervals used for the particle size distribution data

III.3.4 Model limitations and error

The framework limitations derive from the limitations of the main equations proposed in this methodology. The A-P fitting parameters used to derive α for each of the four engineered soils were chosen to the closest of the five soils textural classes for which fitting parameters were developed by A-P (Arya et al, 1999). Specific fitting parameters for computing the value of α for SWM filter media soils might lead to a better fit. A second limitation is that the more non-uniform soil gradation of the engineered soil the more irregularly shaped the $\theta(\psi)$ curve when it is obtained by interpolation of the A-P model generated data points, and this could lead to computational errors when used with Richards' Equation. This shortcoming can be overcome by applying the VG fitting

function to the derived A-P data points instead of interpolation. Another weakness comes from the fact that the A-P model does not account for hysteresis and this could affect the accuracy of continuous long term simulations that includes multiple wetting and drying cycles of the filter media under natural precipitation events.

The correction for the coarse particles as presented here is assumed to be valid for soils with coarse particle content up to 30%, this being the threshold above which the coarse particles becomes predominant and enhance the soil's hydraulic properties. Future work should include a more refined methodology for adjusting the wood chips effects on the MRCs.

Possible model error could be introduced by the fact that the $\theta(\psi)$ curves were measured on the wetting curves only, and the $K_r(\theta)$ curve used for the testing of the proposed framework was computed with Mulaem's Equation using the $\theta(\psi)$ curves, rather than being measured. Given that coarse soils used as filter media in LID systems are less hysteretic, the error in estimating moisture transport through these soils is minimized.

III.4 Conclusion

This article presented a methodology for obtaining the hydraulic characteristics of engineered soils. These characteristics are used to aid in the modeling of unsaturated flow through engineered soils typical of stormwater management systems. The proposed model performed well for the four soil types studied and it is based primarily on physically-based equations that require data input easily accessible to stormwater system design practitioners. A summary of the methodology is as follows:

- Develop the PSD for the soil (filter) media
- Determine the mass percentage of the particles $> 2\text{mm}$, then normalize the PSD of the fine fraction ($< 2\text{mm}$) of the soil to 100%
- Interpolate the coordinates of the normalized PSD of the fine soil fraction with the twenty intervals recommended by A-P
- Apply the A-P model and compute the $\theta - \psi$ data points for each soil fraction
- Evaluate whether coarse particles/wood chips adjustments are needed
- Adjust the θ values corresponding to ψ for the effect of coarse particles with the Bouwer Equation: if wood chips are present, subtract the volume of wood chips from the volume of coarse particles, then convert volume to a mass and apply the Bouwer Equation (Equation 13).
- Extend the data set at saturation to account for the effects of fine and coarse gravel soil fractions in the macropore formation
- Develop the continuous $\theta(\psi)$ function by fitting VG (Equation 14), or spline interpolation if the PSD is smooth
- Obtain the $K_r(\theta)$ function with Mualem model (Equation 7-8).

This sequence of equations does not require extensive computational time and can be easily integrated in existing hydrological software used for SWM system design.

When coupled with watershed models, this framework could be especially valuable in long term continuous simulation analyses and planning of LID-SWM strategies.

Integrated in system scale models, this framework would allow for the prediction of

system performance, as well as optimization of the filter media composition in order to attain targeted discharge hydrographs.

CHAPTER IV

A physical model for stormwater flow simulation through a pervious pavement system: relating the design parameters to the outflow hydrographs

Abstract

Permeable Pavements (PP) are a valuable Low Impact Development (LID) technology that can serve both as stormwater management and transportation infrastructure. PP systems are typically designed for load capacity, hydrologic modification and frost depth criteria. However, the hydraulic design of the system is not specifically addressed in design criteria. Existing stormwater management modeling software possesses the capabilities to represent outflow hydrographs for PP systems, but cannot simulate stormwater routing through the permeable sublayers of the systems. Due to the lack of modeling tools to accurately predict the hydraulic behavior of these systems, engineers, regulators, planners, and industry have some challenges with the implementation and recognition of PP systems as functional stormwater management strategies. This article discusses the flow components of PP systems, presents equations for each segment of flow through the system, and relates the system's design parameters to the final outflow hydrographs. A set of physically-based equations for representing flow through PP systems is tested against real time data monitored for two PP systems. The equations used to model flow through the layered PP system include: the Kuang Equation for flow routing through the PP layer, Richards' Equation for unsaturated flow through the filter media, and Glover's and Manning's Equations for outflow from the

system's underdrains. Special attention is given to the routing of stormwater through the filter media layers in unsaturated conditions. Lag times of the hydrograph peak resulting from the routing through the filter media soils were found to increase with the increase of the layer thickness, following a power function rather than being linear. Similarly, the hydrograph lag time decreases with an increase of the hydraulic conductivity of the soil and also follows a power function.

IV.1 Introduction

Permeable pavement systems are one of the LID technologies that were found to effectively minimize the impacts of urbanization on the water quality of surface water bodies (Boving, 2006; UNHSC, 2012). These systems also serve as transportation infrastructure (Schwartz, 2010). However, the acceptance of PP systems as a functional stormwater management technology continues to face challenges (Houle et al, 2013). This is due in part to: the lack of familiarity with this technology by some reviewing agencies responsible for approval of stormwater management plans for construction projects (Houle et al, 2013); concerns that the pavement's surface might clog over time and prevent rainfall from entering the system; concerns regarding proper system installation; lack of familiarity with maintenance requirements; and the lack of accurate, scientifically-derived modeling tools to predict the hydrologic behavior of PP systems, especially as it relates to changes in design variables.

Correct design and sizing of LID technologies ensures that the cumulative effects of large scale implementation of the technology over time will result in water quality improvement and flood reduction rather than further contribute to environmental

problems. Generally, long-term policy development and implementation strategies of new stormwater management technologies at the watershed level are based on studies which demonstrate that alternatives are superior to existing technology and the fact that conventional strategies are not helping to meet water quality goals. Because demonstration at the watershed scale is expensive, includes many causative variables, and requires long term studies, watershed scale assessments are typically performed with computer simulations that employ urban hydrology software. However, currently available watershed models do not include capabilities to predict hydrologic consequences resulting from individual LID systems such as PP systems. Moreover, accurate modeling at the watershed scale first requires in-depth understanding of the technology's functionality at the system level, and this has not yet been given sufficient attention. The relationship between design variables (layer thickness, media particle size distribution, under drains, etc.) and the system's outcome (outflow hydrograph) has not yet been empirically developed for PP systems (Elliot, 2006). This lack of physically-based modeling of PP systems served as the impetus for this study: the hydraulic modeling of PP systems.

At the moment, there is little available information about how design variables affect the hydraulic performance of the PP systems. Several monitoring studies were performed on built PP systems where the hydrological outcomes were summarized and reported (Dempsey and Swisher, 2003; Boving et al, 2004; Roseen et al, 2006), but there are only a few studies that looked at developing methodologies to empirically model these systems (Jackson and Ragan, 1974; Ladd, 2004; Barbu et al, 2009; Schwartz, 2010). These proposed models are simplified tools that disregard the water routing

through the hydraulically restrictive soil layers in the system, and make the assumption that the system functions under saturated conditions.

IV.1.1 Pervious pavement types and configurations

PP systems are very similar to conventional pavements. However in stark contrast, the PP system is designed to allow stormwater to infiltrate and easily pass into the sublayer materials. PP surface layers can be made of different materials: porous asphalt, pervious concrete, interlocking blocks, or geo-cells filled with gravel or grass (Ferguson, 2005). The pavement layer is typically set on a support layer that can support both its construction and traffic loads. Below the support layer may be multiple sublayers, each serving a different purpose. A common configuration might include: the permeable surface layer, the support layer (a structural layer – in some applications referred to as the choker course, and typically composed of crushed stone) below the permeable surface layer; then a layer of coarse sand/fine gravel (bank run gravel) which serves as a filter media to remove pollutants and slow down the stormwater; and below that another layer of crushed stone which acts as a reservoir to hold water, prevent moisture from moving upwards (frost heave inhibition), allow it to move to underdrains, and/or hold it to allow for infiltration into the native soil in between storms. An example of a PP system configuration is shown in Figure 21. A simpler configuration in high permeability soils might only include the pavement layer and a setting bed consisting of crushed stone. Underdrains are placed in the stone layer at the base of the system if drainage control is needed in low permeability native soils or where infiltration is undesirable. At sites with very high permeability soils, the lower stone layer and drainage piping may be absent. Some designs might exclude the filter media layer, instead opting

for only a crushed stone reservoir. Generally, the configuration of the system is designed to meet site specific objectives, constraints, and needs. However, irrespective of the design configuration, water movement takes place primarily in the vertical direction through these systems until it reaches the native soil or underdrains if present.

From an engineering point of view, a good hydrological simulation model should: assess the effects of each of the sublayer characteristics on the outflow hydrograph from the system; allow the designers to evaluate the contribution of each of the design variables (ie. system geometry, filter media type and depth, drain spacing and diameter or the lack of drains) to the outflow hydrograph (provided that underdrains are present); and require easily accessible data input.

To optimize design parameters and system configuration for targeted outflow hydrographs, simulation tools need to explicitly relate the water flow to the design parameters of interest through empirical equations. This can only be done with physico-empirical equations that explicitly model the flow through each component in the system rather than lumped or regression equations. Existing models (EPASWMM5, PCSWMM , XPSWMM, HydroCAD and other urban hydrology models) do have some capabilities to model the hydraulics and geometry of PP systems, but are missing the capability to route water through the hydraulically restrictive sublayers of the system (Elliot, 2006; Dietz, 2007, Schwartz, 2010) or link design variables to the outflow hydrograph.

IV.1.2 Segments of flow and corresponding equations

Due to limitations of the existing urban hydrology software, PP systems are currently modeled either as storage units with reduced storage space which account only for the pore space in the soils, as black box systems (for example using a lag time or

fictitious curve number to represent the system), or as simple soils. They are modeled with the assumption that water flows under saturated conditions (Ladd, 2004; Barbu et al, 2009; Schwartz, 2010), or that water freely flows to the bottom of the systems and then saturation occurs from the bottom to the top, as moisture is added in the system (Jackson and Ragan, 1974). According to a recent study which monitored the moisture profile in the sub-base of a PP system installed on the University of New Hampshire campus (Alumni lot), (Figure 21), saturation did not occur at any level in the system's sub-base at any time during the study period of a little over one year (Barbu and Ballestero, 2013a). This system did not have any run-on from surrounding impervious areas, the only stormwater received being direct precipitation falling on the surface of the pavement. In this study, the volumetric moisture content (VMC) was measured at 5 minute intervals at different depths in the system's sublayers. The cumulative frequency distribution of the VMC in reference to the VMC at saturation for the four probes installed at different levels in the PP system's sub-base are presented in Figure 22. This demonstrates that the moisture content was well below the saturation point throughout the period of study.

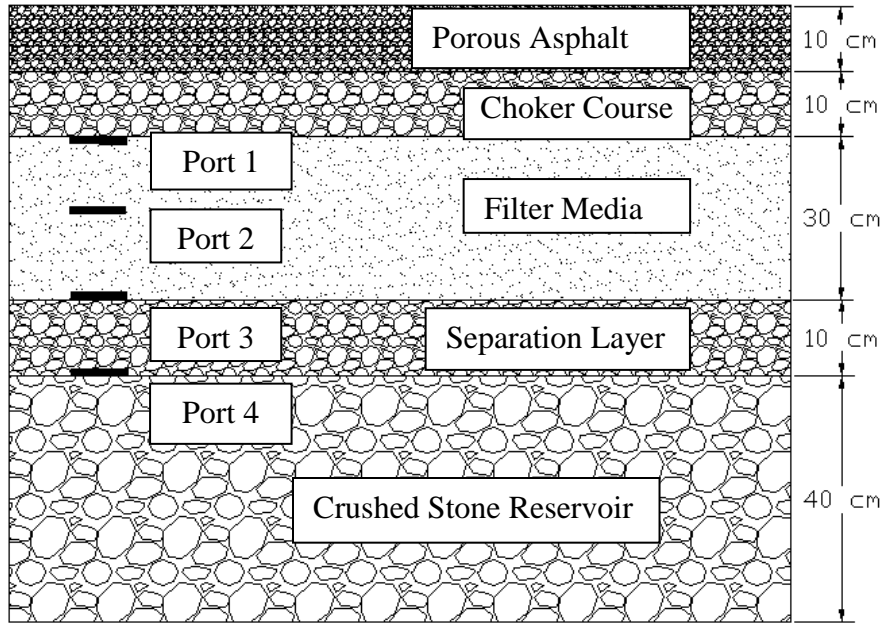

Figure 21 – Cross section of the Alumni lot PP system and location of volumetric moisture content (VMC) sensors

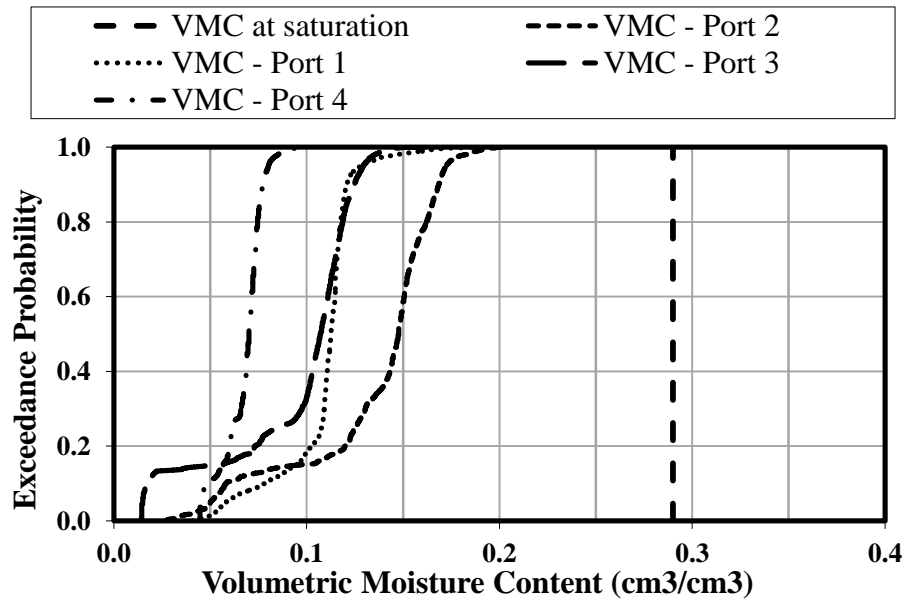

Figure 22 – The cumulative frequency of the VMC at the top (Port 1), middle (Port 2) and bottom (Port 3) of the filter media layer, and at the top of the stone reservoir (Port 4) for one year of monitoring, compared to the measured VMC at saturation in the filter media soil.

When modeling PP hydrology, unsaturated flow conditions are more difficult to mathematically represent than saturated flow and require more data input regarding the soil hydraulic properties, which is not readily available to designing engineers. For any given soil, unsaturated hydraulic conductivities are typically much lower than saturated hydraulic conductivity.

Against this background, the equations selection for modeling flow through the PP system is herein discussed. Modeling decisions to be made regarding the following flow components in the system include: surface infiltration, routing through the permeable layers {surface layer (here porous asphalt), choker, filter media and stone}, infiltration in the native soils, and flow through the underdrains.

Infiltration at the pavement surface: The infiltration capacity of the permeable asphalt layer ranges anywhere from 1,250 to 10,000 cm per hour (UNHSC, 2012) as measured with double ring infiltrometers, a method that creates saturated conditions of the pore space at least at the surface of the asphalt layer. Even in areas where the pavement's surface is partially clogged, the asphalt maintains infiltration rates higher than naturally occurring precipitation rates, and the pavement does not generate runoff, the entire precipitation event being absorbed by the system.

Kuang et al. (2011) measured the hydraulic conductivity of 19 samples of pervious concrete with different porosities. Based on this data, they developed the following power form equation that predicts the saturated hydraulic conductivity of the pervious concrete (K_{sat}) as a function of the total porosity of the permeable asphalt:

$$K_{sat} = 0.0286 * (\phi_t)^{2.0721}$$

Equation 15

Where:

K_{sat} = saturated hydraulic conductivity (cm/min); ϕ_t = total porosity of the pervious concrete (%).

Equation 15 is valid for permeable pavements with porosities up to 20%. The pervious asphalt in the present study had porosities of approximately 18%. Based on Equation 15 the saturated hydraulic conductivity of this pavement is 46 cm per hour, which is vastly different than infiltration capacities measured in the field with the double-ring infiltrometer (UNHSC, 2012).

Barbu and Ballestero (2013a) found that the average time for precipitation to percolate through the permeable pavement and the choker course layers of the PP system in Figure 21 (the lag time from the beginning of precipitation to when a moisture content change was detected at Port 1) was on average 2.45 hours. This time most likely includes the initial abstractions of precipitation on the asphalt surface. Nevertheless, it is a reflection of lag times at field conditions under natural precipitation. Based on this study, the average hydraulic conductivity through the combined pervious asphalt and choker layers is approximately 8.2 cm per hour. In spite of the very high potential infiltration capacities of both PP layer and the 1.8 cm (3/4") crushed stone choker course, the actual infiltration is much lower. This is most likely due to the fact that water moves slower under unsaturated condition (field condition) than at saturation (inundation tests).

Choker course: Due to the high potential infiltration capacity of uniformly graded crushed rock materials, even in unsaturated conditions the water moves very fast through

this layer under gravitational forces. However, the water flow through this layer is restricted by the flow through the PP layer above. In unsaturated conditions, the travel time through this layer is comparable to that through the PP layer, and can be simulated by a delay of the precipitation with observed lag-times (Barbu and Ballesterro, 2013a). In the case of saturated conditions created by water building up above the filter media layer, the choker course could be represented as storage, with the outflow being limited to the infiltration capacity of the underlying soil layer.

Filter media: Filter media in PP systems consist of mineral soils in the sand and gravel textural classes. Proposed equations for modeling filter media for PP systems or other LID filtration systems include: Darcy’s Law (Lucas, 2010), the original Green-Ampt Equation (Dussaillant, 2003; Jayasuriya, 2008; Aad, 2010), the modified Green-Ampt solution (Lee, 2011), and Richards’ Equation (Dussaillant, 2004; Browne, 2008). These equations, with the exception of Richards’, are valid only for saturated flow. Based on the findings of Barbu and Ballesterro (2013a), which recognized that flow through a PP filter media layer takes place under unsaturated conditions, it is suggested that Richards’ Equation should be used instead of saturated flow equations. Richards’ Equation (Richards, 1931) can be derived with the moisture content (θ) or matric potential (ψ) as the dependent variable, or in a mixed form that depends on both θ and ψ . The equation in its moisture based form is:

$$\frac{\partial \theta}{\partial t} = \frac{\partial \left[D(\theta) \frac{\partial \theta}{\partial z} + K_r(\theta) \right]}{\partial z}$$

Equation 16

Where:

$\delta\theta$ = the change in volumetric moisture content (-); δt = the time interval for analysis (T);
 δz = the space interval/depth of layer (L); $\delta\psi$ = the change in matric potential (L^{-1}); K_r =
hydraulic conductivity(L/T); and D = water diffusivity(L^2/T);

Solving Equation 16 requires first knowing the moisture characteristic curves, $\theta(\psi)$, and the relative hydraulic conductivity function, $K_r(\theta)$, which are unique for each soil. Generally, the $\theta(\psi)$ curve is measured in the laboratory or estimated with Van Genuchten fitting equations (Van Genuchten, 1980), and the $K_r(\theta)$ function is commonly derived with Mualem's Equation (Mualem, 1976). Measurements of the $\theta(\psi)$ relationship in the laboratory can take 12 to 14 weeks and even longer for fine particle soils (Dane and Topp, 2002).

Stone reservoir and underdrains: These are commonly modeled with storage indication methods and the Manning Equation, or the orifice equation for systems that function under outlet control (Ferguson, 1998, pp. 127-133). Other alternatives for the flow through the drains include the Dupuit formula, (Krebs and Walker, 1971), Glover's parallel drain equation (Glover, 1974), or the Hooghoudt drainage equation (Hooghoudt, 1940).

Infiltration in the native soils: This is typically modeled with Darcy's Equation (Darcy, 1856), under the assumption that water accumulates above the native soil surface, however this could also subscribe to Richard's Equation.

The development of a physically-based model that explicitly models each flow component of the system and relates the final outflow hydrograph to the system design parameters – particularly those related to the filter media soil – is further explored. Real

time precipitation, moisture profiles in the system's sublayers, and outflow collected at two PP sites on the University of New Hampshire's campus are used for the calibration and validation of the model.

IV.2 Materials and Methods

IV.2.1 Site description

The main PP testing site at the University of New Hampshire Stormwater Center (UNHSC) is the West Edge lot, which was built in 2006 as part of the University of New Hampshire Stormwater Center field research facility. This 483 m² (5200 ft²) PP site is located adjacent to the West Edge Commuter Parking lot. Although this PP site is hydrologically disconnected from the rest of the parking lot, it does receive minimal run-on from the 37 m² dense mix asphalt curb on the perimeter of the actual permeable asphalt surface during rainfall events. Also, in the winter time, a considerable amount of snowmelt from the snow banks surrounding the site can enter the sublayers of the PP systems through the crushed stone shoulder surrounding its perimeter. For this reason, only summer data was used for the model calibration and verification in this study. The native soils under the PP site consist of a silt clay with a low infiltration rate of approximately 0.5 cm/hour. The system configuration and layout are shown in Figure 23.

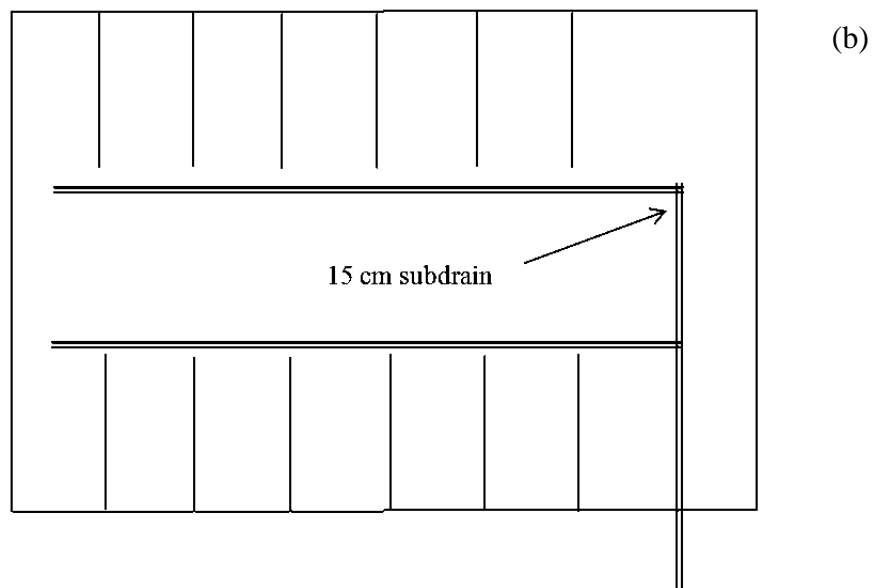
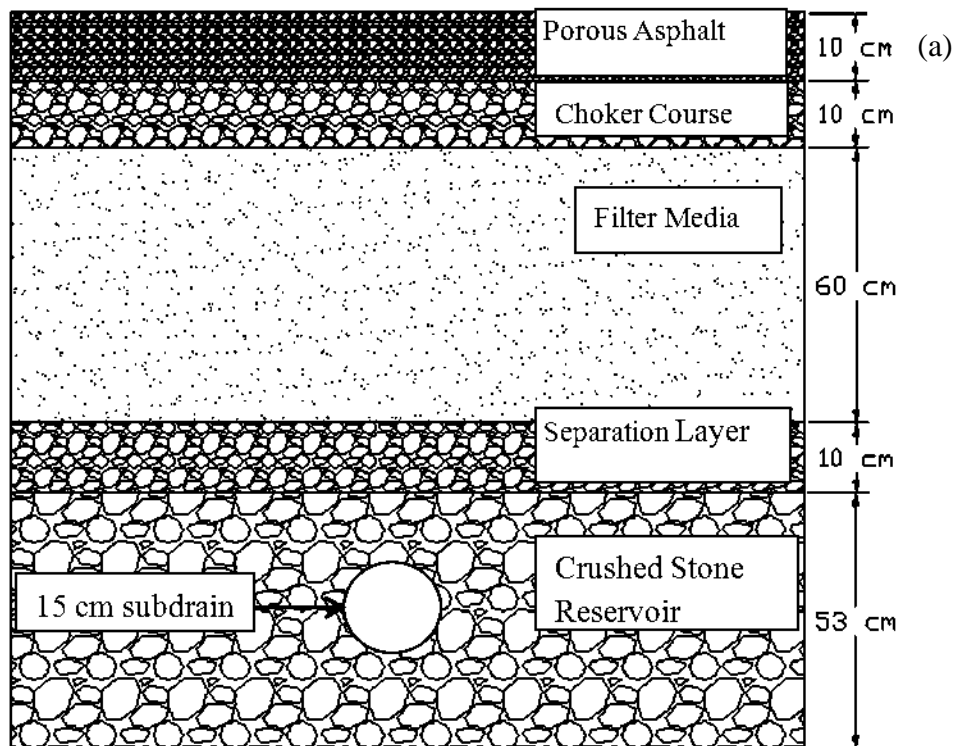

Figure 23 – The cross section (a) and plan view (b) of the PP system at West Edge parking lot. The outflow hydrograph is measured at the end of the subdrain.

The Alumni lot system (Figure 21) is the second UNHSC testing facility. This system is designed similarly to the main testing site, except that this system was designed with a shallower filter media depth (30 cm instead of 60 cm) and stone reservoir (40 cm instead of 53 cm). The bank-run gravel soil used as the filter media in the Alumni lot originated from the same source as that used in the West Edge lot. The difference is that the former has less gravel content (soil particles greater than 2mm). The particle size distribution comparison of the two soils is presented in Figure 24 . Since the Alumni lot system does not have subdrains, no outflow data is available from this site. Only precipitation and moisture profiles in the PP system sublayers were collected for this lot. A modeling module for flow routing through the filter media was first developed and calibrated for the Alumni system. This was then incorporated into the complete PP system model developed for the West Edge system which possessed outflow hydrographs from its subdrains. Precipitation and outflow data were collected continuously from 2005 to 2009 at the West Edge parking lot.

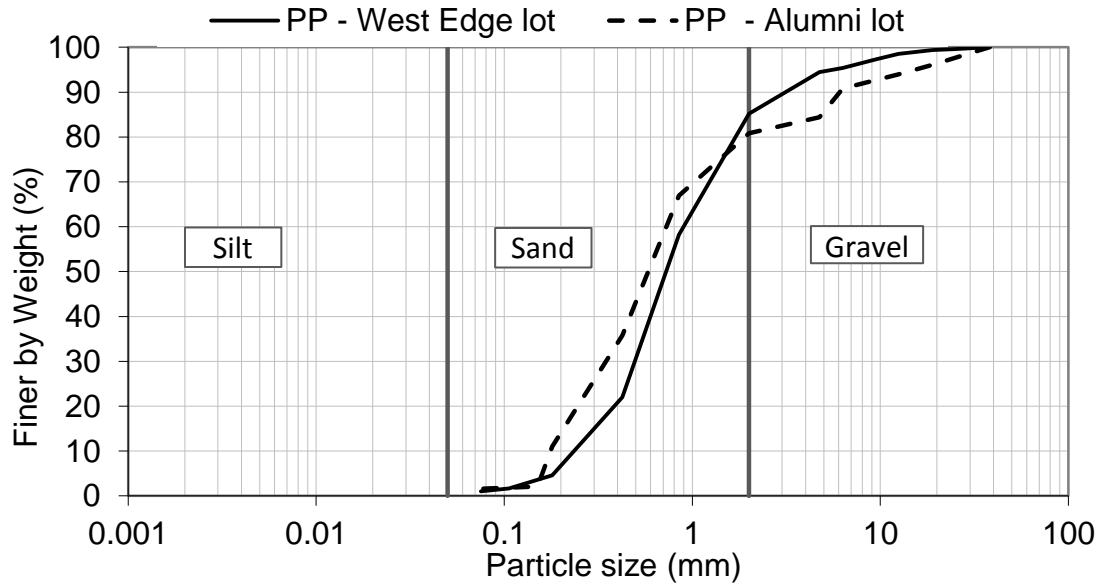

Figure 24 – Particle size distribution of the soils used as filter media in the West Edge and Alumni PP systems

IV.2.2 Monitoring and data calibration

Concurrent, real time precipitation and outflow data at the West Edge lot was collected at 5 minutes intervals. Precipitation data was collected with a NOAA rain gage located 0.5 km (0.3 miles) away from the location of the main testing site. Flow measurements were taken continuously at the end of the subdrain with a water stage recorder (ISCO bubbler) coupled with a Thelmar compound weir. The accuracy of the automatic flow measurements was verified with a “bucket and stop watch” method. The comparison of the two flow measurements is presented in Figure 25. Based on the close agreement of the two types of measurements ($r^2 = 0.967$), calibration was not needed for the automated flow measurements. Therefore, the original data was further used for the model calibration and verification. After data underwent quality control by checking for

any instrumentation error, eight independent storm events were selected for model calibration and verification (Appendix H).

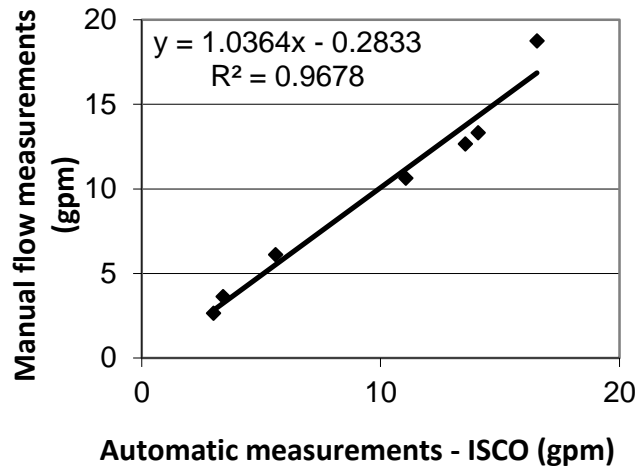

Figure 25 – Comparison of the “bucket and stop watch” flow measurements and automated flow measurements recorded by ISCO bubblers coupled with a Thelmar weir and manufacturer’s rating curve

Real time VMC data was measured at 5 minute intervals at the top, middle, and bottom of the filter media layer of the Alumni lot for 14 months. This data was used for the calibration of the unsaturated flow module developed for the filter media component.

IV.2.3 Model development

The one dimensional moisture transport model was developed in Matlab, 2009a. The precipitation is carried through the system as units of depth until it reaches the native soil at the base where it is allowed to back up in the basal stone layer or the groundwater table, wherever that may reside. Once it reaches the stone reservoir, the water depth is converted to a volume and then the outflow hydrograph is generated with Glover’s parallel drain equation. The segments of flow identified in the system, recommended

equations for modeling these flow components, and data input needs are presented in Table 13.

Surface infiltration and flow through the PP layer and choker course: The infiltration capacities were measured (double-ring infiltrometer or other inundation test) periodically at the West Edge site for over 8 years and were in the range of thousands of centimeters per hour (UNHSC, 2012). Surface runoff was never observed at this site. Thus, it was assumed for the purposes of modeling that surface runoff generation does not occur and that the total amount of precipitation enters the PP system. The flow through the PP layer and choker course was modeled with Kuang's Equation (Equation 15), as it produces lag-times closer to the observed data at the Alumni lot (Barbu and Ballester, 2013a).

Table 13 – Segments of flow identified in the PP system, recommended equations and data input needed

Flow component	Equation	Data input / Design parameters being related to the outflow hydrograph
Precipitation	N/A	Real time rainfall data, or design storms
Permeable pavement layer	Kuang Equation	Total porosity of the asphalt layer
Choker layer	Not explicitly modeled; reservoir equation if storage is needed in this layer	N/A; Geometric dimensions
Filter media layer	Barbu framework for the $\theta(\psi)$ and $K_r(\theta)$ relationships (Barbu and Ballester, 2013b), and Richards' Equation (Richards, 1931)	Particle size distribution, porosity, density, saturated hydraulic conductivity
Stone reservoir and drains	Reservoir coupled with Orifice Equation or Manning's Equation, or Glover (Glover, 1974) combined with mass conservation conditions	Geometric dimensions of the storage and pore space available; and subdrains diameter, length, and spacing
Infiltration of the native soils	Darcy (Darcy, 1856)	Saturated hydraulic conductivity

Flow through the filter media was represented with the moisture based form of Richard's Equation (Equation 16), which was solved using a finite difference scheme as described by Tuteja (Tuteja et al, 2004). The soil profile was discretized in M layers with a thickness $\Delta z = \text{depth of filter media} / M$. The change in moisture content (θ) was tracked through the soil profile, as computed with Equation 17 – 19. The θ matrix representation is described in Figure 26, where j, j-1, and j+1 indicate the position in the finite difference mesh, and t, t-1, and t+1 indicate the time steps of the iteration. The soil profile was discretized with a $dz = 2.5 \text{ cm}$ (1 inch), and the time step was selected as $\Delta t = 1$ minute, as recommended in a similar study by Browne (Browne et al, 2008).

Solving Richards' Equation at the saturation end where there are steep matric potentials can create mathematical errors (convergence problems). To address this, the derivative interpolation of the moisture content was first performed for the entire range of values and was used in conjunction with Richards' Equation.

The flow at the bottom of the filter media was computed with Equation 20. Given that the crushed stone underneath the filter media layer is an opened pore layer that drains freely, the flux from the lower boundary of the filter media is controlled only by the hydraulic conductivity of the filter media soil and is not restricted by the underlying layers.

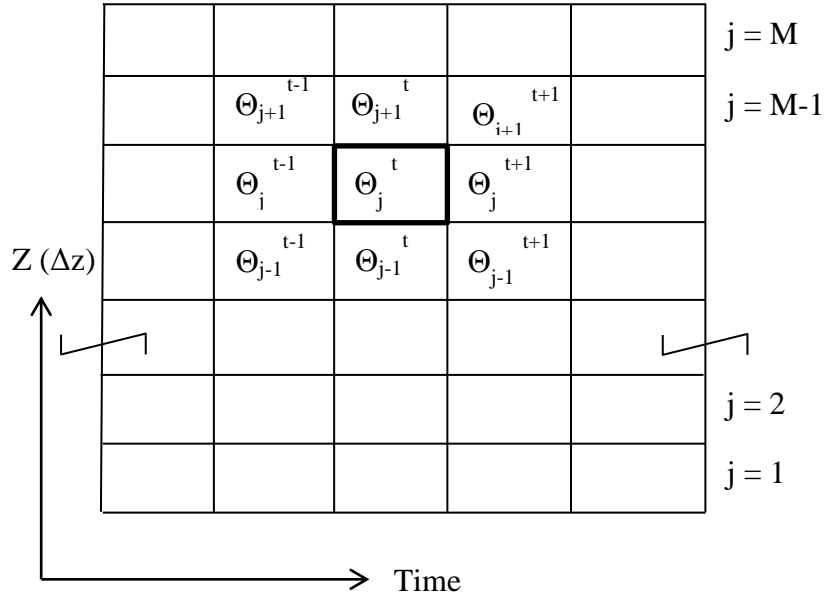

Figure 26 – Representation of θ through the filter media layer in space and time

$$\theta_M^{t+1} = \theta_M^t + \frac{I^t}{\Delta z} + \left(-\sqrt{D(\theta_{M-1}^t) * D(\theta_M^t)} * \left(\frac{\theta_M^t - \theta_{M-1}^t}{(\Delta z)^2} \right) - \sqrt{\frac{K(\theta_M^t) * K(\theta_{M-1}^t)}{\Delta z}} \right) * \Delta t$$

Equation 17 – Top Layer

$$\theta_j^{t+1} = \theta_j^t + \left(\sqrt{D(\theta_{j+1}^t) * D(\theta_j^t)} * \left(\frac{\theta_{j+1}^t - \theta_j^t}{(\Delta z)^2} \right) + \sqrt{\frac{K(\theta_{j+1}^t) * K(\theta_j^t)}{\Delta z}} - \sqrt{D(\theta_j^t) * D(\theta_{j-1}^t)} * \left(\frac{\theta_{Mj}^t - \theta_{j-1}^t}{(\Delta z)^2} \right) - \sqrt{\frac{K(\theta_j^t) * K(\theta_{j-1}^t)}{\Delta z}} \right) * \Delta t$$

Equation 18 – Middle Layers

$$\theta_1^{t+1} = \theta_1^t + \left(\sqrt{D(\theta_2^t) * D(\theta_1^t)} * \left(\frac{\theta_2^t - \theta_1^t}{(\Delta z)^2} \right) + \sqrt{\frac{K(\theta_2^t) * K(\theta_1^t)}{\Delta z}} - \left(\frac{K(\theta_1^t)}{\Delta z} \right) \right) * \Delta t$$

Equation 19 – Bottom layer

$$Flow_j^t = \left(\frac{K(\theta_j^t)}{\Delta z} \right) * \Delta t$$

Equation 20

Where:

Δz = depth of the discrete soil layer (L); Δt = time interval for moisture redistribution (T);
 j = space iteration (-); t = time iteration; I^t = precipitation rate, or inflow from the layers
above (L/T); θ_j^t = moisture content for layer j at time t (-); $D(\theta_j^t)$ = diffusivity for layer j
at time t (L²/T); $K(\theta_j^t)$ = relative hydraulic conductivity of layer j at time t (L/T); $Flow_j^t$ =
flow at the bottom of the filter media (L/T).

The θ (ψ) and K_r (θ) relationships needed to solve the unsaturated flow function (Equation 16) are typically measured in the laboratory or developed with Van Genuchten (1980) and Mualem (1976) equations. Since the filter media soil is a coarse engineered soil disturbed and repacked at recommended compaction degrees, typical equations used to derive the moisture characteristic curves do not apply to this type of soil (Gribb et al, 2009). The θ (ψ) and K_r (θ) relationships for the filter media soil function were obtained with the framework developed in Barbu and Ballestero, (2013b). This framework starts with data input easily available to design engineers (such as porosity and PSD) and derives a complete curve from residual moisture content to saturation, which allows for the simulation of stormwater routing through the restrictive layers of PP systems. This sequence of equations adds little computational time to the total analysis time for water

flow simulation through the system. The main equations included in this framework include the Arya-Paris model (Arya and Paris, 1981) for the development of the $\theta(\psi)$ relationship, the Bouwer Equation (Bouwer, 1984) for gravel content adjustment along with an extension to the saturation portion of the curve (Barbu and Ballesterro, 2013b), and the Mualem model (Mualem, 1976) for the development of the $K_r(\theta)$ function. The PSD of the filter media bank-run gravel in the West Edge system and its corresponding $\theta(\psi)$ and $K_r(\theta)$ curves derived with this framework are presented in Figure 27.

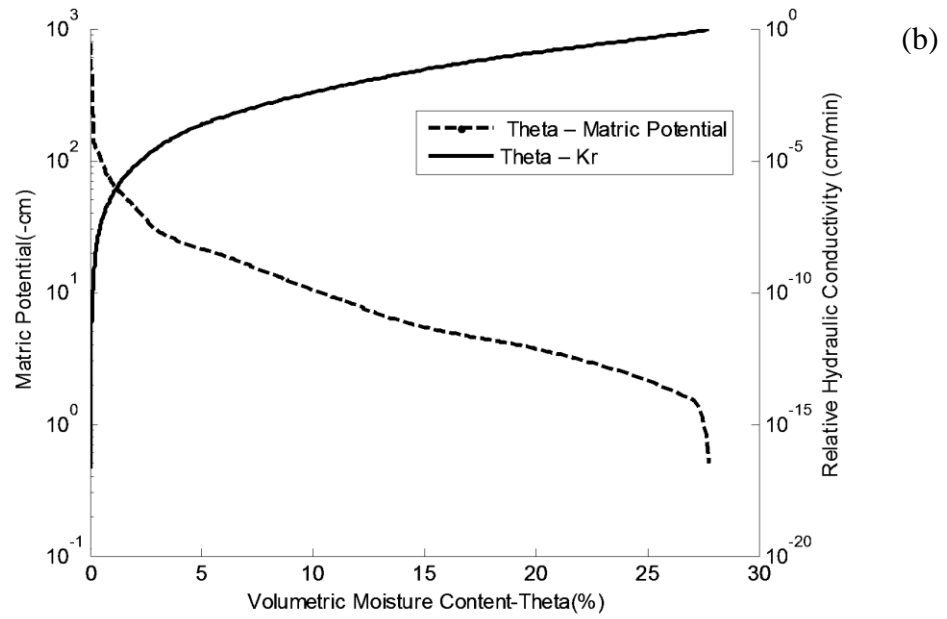
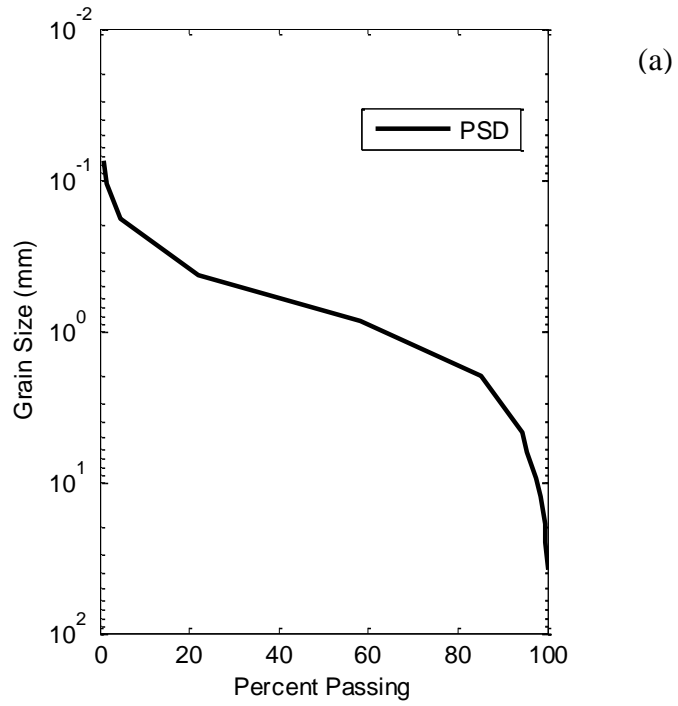

Figure 27 – The particle size distribution (a) of the filter media soil in the West Edge lot and the resulting θ (ψ) and Kr (θ) curves (b) as derived after Barbu and Ballesterio, 2013b.

Flow through the underdrains: was modeled with the parallel drain equation developed by Glover for transient water flow in soils (Glover, 1974) (Equation 21), and the Manning Equation (Manning et al, 1890)(Equation 22):

$$q = \frac{8iL}{\pi^2} * \sum_{n=1,3,5\dots}^{\infty} \frac{1}{n^2} - \frac{8iL}{\pi^2} * \sum_{n=1,3,5\dots}^{\infty} \frac{e^{-n^2 \pi^2 \left(\frac{\alpha t}{L^2}\right)}}{n^2}$$

Equation 21

Where:

i = recharge rate (L/T); q = flow from one side of a drain (L³/T); D = depth of water in the soil (L); α = aquifer constant (-); ϕ = soil porosity (-); L = distance between parallel drains (L); t = time interval for the analysis (T), K = hydraulic conductivity of the soil (L/T).

$$Q = \frac{1}{n} * A * R^{2/3} * S^{1/2}$$

Equation 22

Where:

Q = Flow through the pipes (L³/T); n = Manning's roughness coefficient; A = Cross sectional area of the pipe (L²); R = the hydraulic radius (L); S = the slope of the water surface (L/L).

IV.3 Results and Discussions

IV.3.1 Derivation of the θ - ψ - K_r functions for the Alumni lot

The framework described in Barbu and Ballestero (2013b) for deriving the complete θ - ψ - K_r curves was applied to the bank run gravel used as filter media in the

Alumni system. The effectiveness of this framework in conjunction with Richards' Equation for modeling flow routing through the filter media was verified with the monitored real time VMC data recorded at three different levels in the filter layer.

The PSD curve for the Alumni lot filter media displayed significant irregularities (Figure 28a) This was also reflected in the $\theta(\psi)$ curve generated with the original Arya-Paris (A-P) model (Figure 28b). The Van Genuchten (VG) Equation was fitted to the A-P generated data points, and this curve was further used for the flow routing routine. The VG fitting parameters for this soil are as follows: $\theta_s = 0.26$; $\theta_r = 0.025$; $\alpha = 0.175$; and $n = 1.97$. The $\theta-\psi-K_r$ relationships developed for this soil are shown in Figure 29.

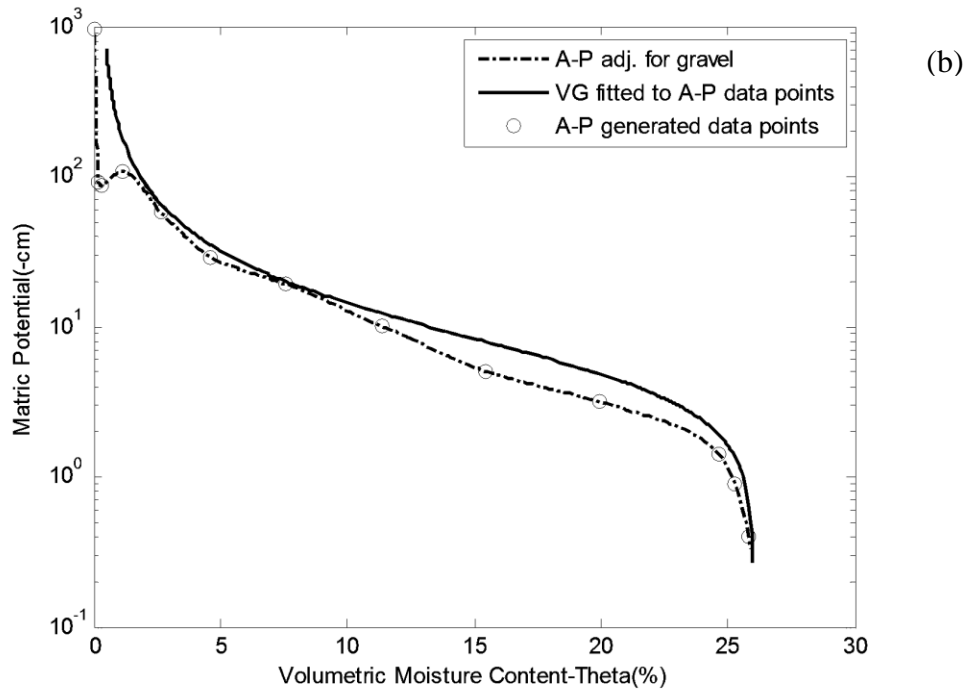
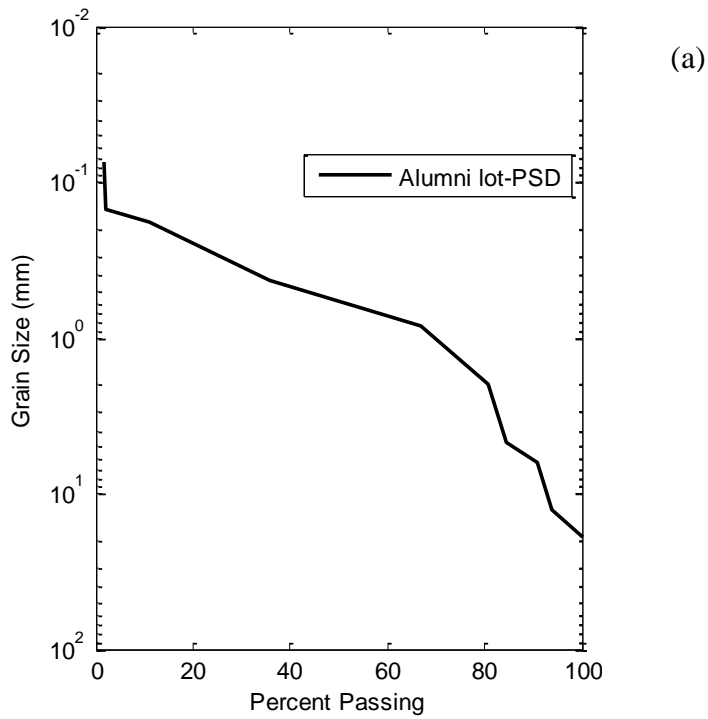

Figure 28 – The particle size distribution of the filter media soil in the Alumni lot (a), and the θ (ψ) curve obtained by interpolation and fitted with VG Equation to the A-P generated data points (b)

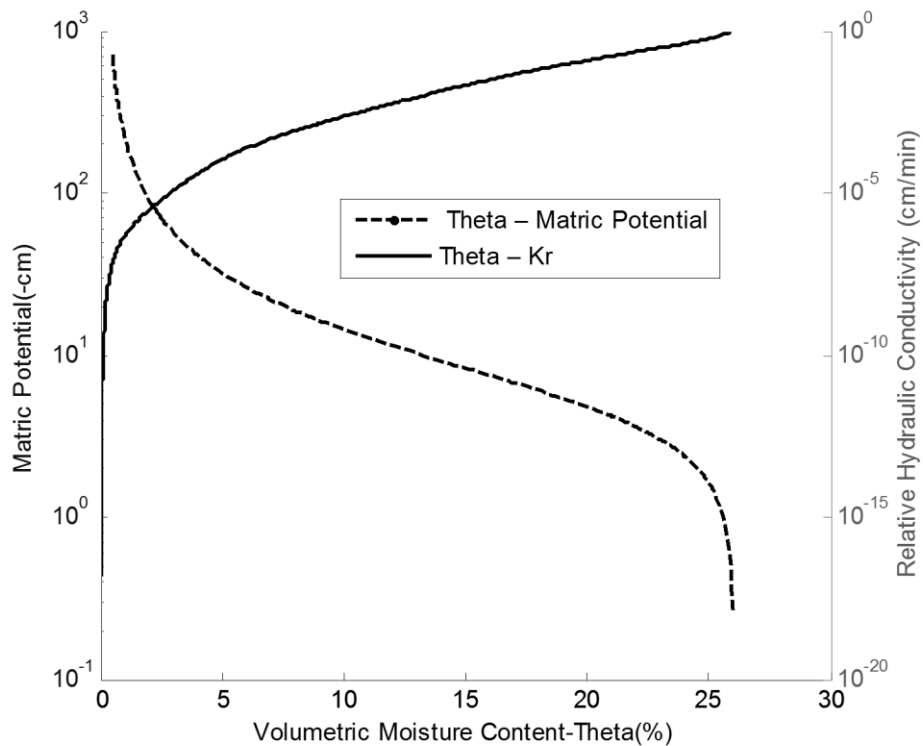

Figure 29 – The θ (ψ) and K_r (θ) curves for the Alumni lot filter media as derived with Barbu methodology (Barbu and Ballesterro, 2013b)

IV.3.2 Water routing through the filter media – Alumni lot

The obtained θ – ψ – K_r curves were then used to solve the unsaturated flow equation to route precipitation through the filter media of the Alumni lot. Since the effectiveness of the proposed framework for the θ – ψ – K_r curves development was verified with laboratory measurements for this soil (Barbu and Ballesterro, 2013b), none of the parameters that are involved in this method were changed during calibration of the flow routing module. The only parameters that were used for calibration were K_{sat} , and the initial θ in the soil profile. Real time VMC data observed in this system showed that the moisture content throughout the profile is not uniform and varies at each depth in the

layer. As the moisture content of the soil at the beginning of each storm for the Alumni lot was known, the actual values were used for θ initialization. However, it was found that the initial θ is not very important as the model converges after a short number of time step iterations. Shorter convergence time was observed when θ initial was set from 5 to 10% VMC.

Three storms with precipitation depths over 2.5 cm (1") were used for calibration of the K_{sat} values and three other storms were used for verification (Appendix I). Although the system functions under unsaturated conditions, K_{sat} plays an important role in the flow routine, as this value is used to scale the K_r curve (Figure 29) used in Richard's Equation. K_{sat} was varied from 0.21 cm/min to 1.27 cm/min, which is the equivalent of 3 to 18.3 meters/day (10 to 30 ft/day) – the range recommended by filter media design standards (UNHSC, 2009). The best fit for the moisture content at the top, middle, and bottom of the filter media, the three levels at which the VMC was monitored in the Alumni lot, was obtained for a K_{sat} of 0.25 cm/min. As an example, the modeled and measured VMC at the three depths in the filter media layer during the 11/04/2010 precipitation event are shown in Figure 30. Additional storm events used for calibration and verification of the flow routine are shown in Appendix J.

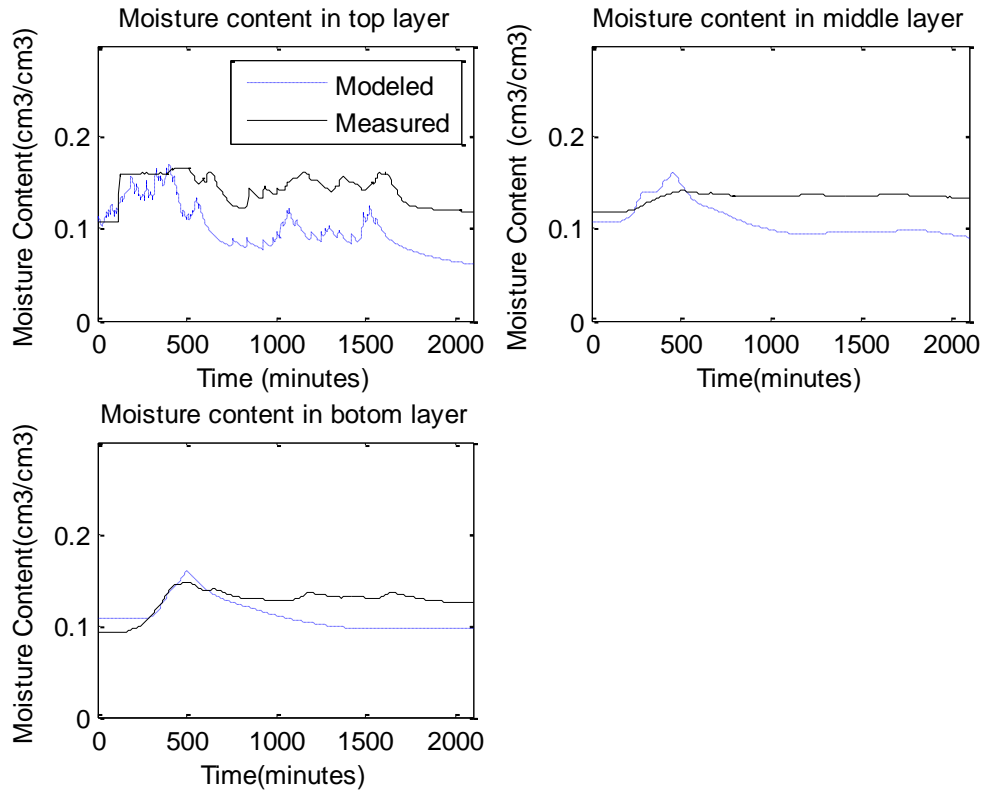

Figure 30 – The VMC in the filter media soil profile in response to the 11/04/2010 precipitation event (total depth of 3 cm). $K_{sat} = 0.75$ cm/min. θ initial was set to observed VMC values at each level

When solving Richards' Equation, the change in moisture content, θ , is computed in each layer with Equation 17 through 19, and is updated after each time step for moisture inputs and outputs through diffusivity and conductivity. The corresponding matric potential and K_r are then updated for the new θ , based on the θ - ψ - K_r relationships in Figure 29. Generally, the changes in the moisture content in response to precipitation are larger at the surface of the filter media, and become more moderate as the water diffuses to greater depths. This phenomenon was represented well by the model (Figure

30), although the changes in modeled VMC were more prominent than the changes in the measured data.

The water moves through the soil profile driven by gravity and the moisture gradient (the difference in moisture content over two consecutive layers), $(\theta_j - \theta_{j-1})/\Delta z$, and therefore the correct representation of the moisture gradient becomes equally important to that of the actual moisture content in the soil. The computed and observed moisture gradient in the top half and the bottom half of the filter media soil for the 11/04/2010 precipitation event are presented in Figure 31a. It is apparent that the values of the modeled VMC vary more than the observed values, the model slightly overreacting to the change in moisture content. When the moisture gradient becomes larger, the water moves faster through the soil profile. However, Figure 31 a and b show that the model overestimates the higher VMC and underestimates the lower VMC almost in equal measure, and balances out over the time of the analysis.

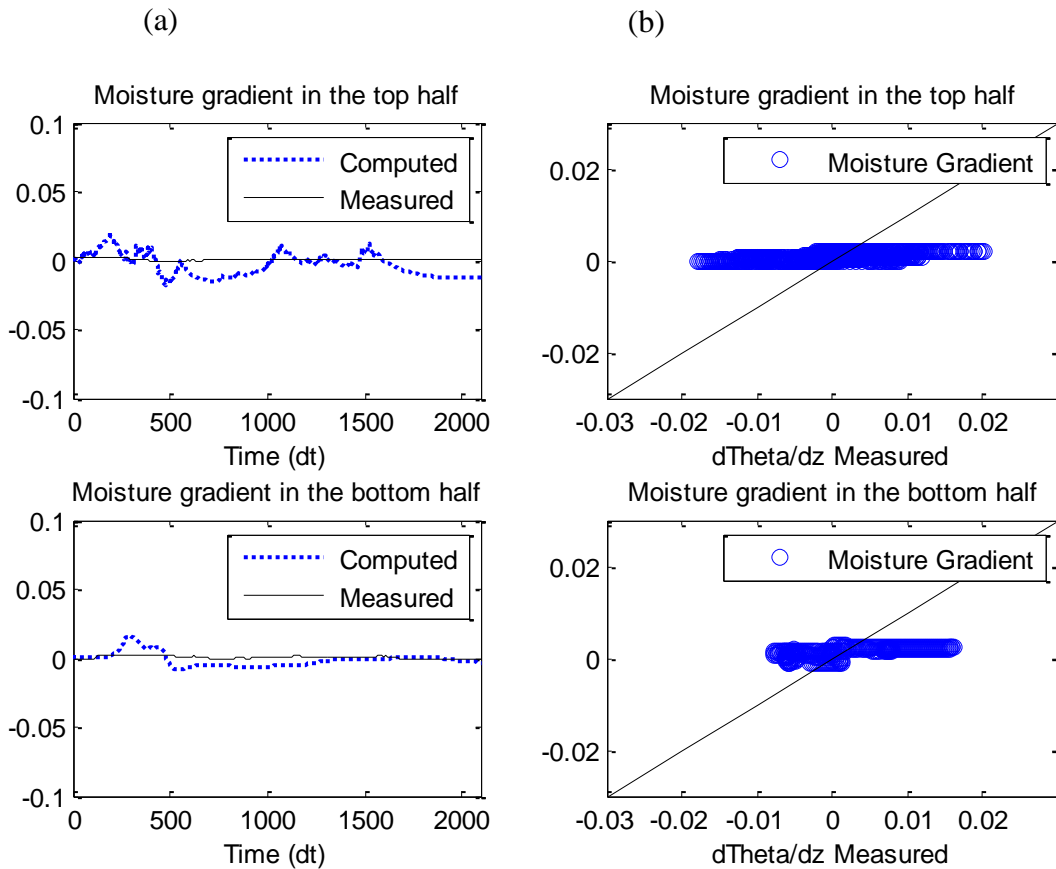

Figure 31 – The moisture gradient in the top half and bottom half of the filter media, computed as the difference between the VMC at the upper and lower boundaries of the two halves of the filter media

According to Legates and McCabe (1999), the goodness of fit of hydrological models should include both statistics of relative error measures and absolute error measures. Therefore, the fit of the modeled VMC to the observed data was tested with the index of agreement (d) developed by Willmott (1981) for the first category and the root mean square error (RMSE) and mean absolute error (MAE) for the second category. The index of agreement (d) is proposed as an alternative to the coefficient of determination (r^2) for hydrological studies (Legates and McCabe, 1999). Similarly to r^2 , the index of

agreement is dimensionless and can vary from 0 to 1, with 1 being perfect agreement.

The MAE and RMSE have the units of the parameter evaluated. Lower values indicate a better fit.

When comparing the computed to measured VMC at the three levels in the filter media, both MAE and RMSE indicators had relatively low values and were mostly positive, signifying that the model performed well, but is generally overestimating the VMC (Table 14). High d values show an overall good performance of the flow routine simulating water movement through the filter media. The good fit indicated by high values of the index of agreement for Port 3 (at the bottom of the filter media) is especially important (Table 14), as this is the location where the outflow hydrograph for the filter media layer is generated.

Table 14 – The “goodness of fit” analysis for routing stormwater through the filter media of the Alumni lot with Richard’s Equation and Barbu framework for obtaining the θ – ψ – K_r curves (Barbu and Ballestero, 2013b), and the initialization parameters.

	Storm Event	K_{sat} (cm/min)	θ_{in} (% VMC)	RMSE (% VMC)			MAE (% VMC)			d (-)		
				Port1	Port2	Port3	Port1	Port2	Port3	Port1	Port2	Port3
Calibration Storms	11/04/2010	0.25	10.7	0.10	0.07	0.05	4.0	2.5	1.6	0.484	0.407	0.730
	11/07/2010	0.25	11.3	0.11	0.07	0.04	3.3	1.8	0.8	0.617	0.588	0.898
	11/16/2010	0.25	11.0	0.13	0.08	0.05	3.2	1.0	-0.3	0.717	0.876	0.989
Verification Storms	11/26/2010	0.25	10.8	0.12	0.08	0.03	2.7	2.3	0.4	0.548	0.264	0.948
	04/10/2011	0.25	10.9	0.12	0.09	0.04	2.7	2.7	-0.6	0.600	0.305	0.821
	04/13/2011	0.25	11.0	0.09	0.13	0.03	3.2	5.1	-0.6	0.661	0.305	0.858

IV.3.3 The complete PP system model – West Edge lot

Once calibrated and knowing its weaknesses, the flow routing routine through the filter media developed for the Alumni lot was integrated into the complete PP system hydraulic model for the West Edge lot. Since the soil used in the filter media for both systems came from the same source, the PSDs were very similar (Figure 24). The difference is that the Alumni lot filter media had a gravel content of 19%, which is slightly higher than the one for the West Edge lot at 15%. This most likely affects the hydraulic conductivity of the two soils. Gravel particles in finer soils were found to impede water flow (Barbu and Ballesterro, 2013b). The appropriate PSD and gravel content were updated for the West Edge soil in the θ - ψ - K_r routine. Based on the calibration of the model for the Alumni lot filter material, the K_{sat} for the West Edge soil was initially set to 0.25 cm/min and was subject to later calibration. The VMC was initialized as constant throughout the soil profile and ranged from 5 to 10% VMC for individual storm events.

The effectiveness of the filter media flow routine along with Kuang, and Glover Equations to replicate observed hydrographs for this system was then evaluated for eight independent storm events (Appendix H). K_{sat} for the filter media in the West Edge lot was calibrated at 0.75 cm/min. The Manning Equation was also tested as an alternative to the Glover Equation. The “goodness of fit” of the generated hydrographs to the measured hydrographs was tested with the index of agreement (d), the root mean square error (RMSE), and mean absolute error (MAE). The statistical analysis was performed for the hydrographs generated at the bottom of the filter media layer and the hydrograph at the

end of the pipe generated with Glover and Manning Equations, as compared with observed hydrographs for the system.

Table 15 – The “goodness of fit” analysis for the flow modeled with Glover Equation, Manning Equation, and flow at the bottom of the filter media layer, compared with the observed flow at the end of the subdrain

Storm event	RMSE (liters)			MAE(liters)			Index of Agreement, d (-)		
	Observed vs Glover Eq.	Observed vs Manning Eq	Observed vs Filter Media output	Observed vs Glover Eq.	Observed vs Manning Eq	Observed vs Filter Media output	Observed vs Glover Eq.	Observed vs Manning Eq	Observed vs Filter Media output
06/11/2009	0.027	0.039	0.031	-1.093	-1.139	-1.481	0.928	0.916	0.881
06/18/2009	0.023	0.023	0.021	1.568	1.368	1.348	0.896	0.915	0.917
07/02/2009	0.034	0.043	0.029	1.873	1.884	1.496	0.839	0.821	0.899
07/07/2009	0.017	0.014	0.014	1.133	0.789	0.787	0.818	0.904	0.904
07/23/2009	0.182	0.216	0.170	1.749	1.079	0.974	0.986	0.995	0.996
08/21/2009	0.020	0.022	0.023	-0.642	-0.033	-1.289	0.928	0.995	0.786
08/28/2009	0.053	0.053	0.062	-1.909	-0.589	-2.567	0.900	0.991	0.842
09/11/2009	0.035	0.029	0.046	-1.592	-1.635	-2.145	0.626	0.611	0.475

An example of the modeled filter media moisture conditions of the West Edge lot during the 07/23/2009 storm event is presented in Figure 32 and demonstrates that saturation of the filter media did not occur during this precipitation event with a total depth of 4.5 cm. The close agreement of the peak time of the modeled hydrograph at the bottom of the filter media, the modeled hydrograph at the end of the subdrain (Glover and Manning Equations) and the observed hydrograph at the end of the pipe (Figure 33) suggests that there was no storage available under the drains for this event at the time that the water passed through the filter media; therefore, water was directly drained out of the system. This also suggests that the Glover Equation effectively represented the drainage once water reached the drain's invert. Since the system is built in a silt clay native soil with very low infiltration rates and there was known to be a high water table during wetter times of the year, the water level in the system was set at the base of the drain and was further analyzed for individual storms. The comparison of the modeled and observed hydrographs for seven other storm events is shown in Appendix K. An important observation is that the timing of the modeled peak flow at the bottom of the filter media and the timing of the observed peak of the hydrograph to the end of the subdrain pipe coincides for most of the storms analyzed. This also suggests that the storage in the stone reservoir below the subdrain invert was not available at the beginning of the storms and that the drains were very efficient at draining the new precipitation after it was routed through the filter media layer.

Hydrograph peak flow

The final outflow hydrograph was generated with both Glover and Manning Equations, which are two different types of flow generating approaches. With the Manning Equation, the flow through the drain is controlled by the drain diameter. The flow can be modeled with the aid of a rating curve that relates the flow to the water depth in the stone reservoir. With Glover, the flow through the pipes is controlled by the hydraulic conductivity of the soil surrounding the drains, rather than the diameter of the pipe. Originally, the Glover Equation was developed for agricultural soils: finer particle soils than the crushed stone used for the PP basal reservoir. In order to match the observed hydrographs, the hydraulic conductivity of the crushed stone used in the Glover equation was calibrated at 122,000 m/day (400,000 ft/day), which is one order of magnitude higher than K_{sat} commonly used for crushed stone. Due to these high hydraulic conductivities, the parallel drain equation did not significantly delay the hydrograph after it passed through the filter media, and the hydrograph passed through the subdrains almost as soon as it reached them. However, both the Glover Equation and the Manning Equation replicated well the timing of the observed peak flows for most of the storms. We suggest that the Glover Equation might be more appropriate if the drains are placed in finer soils rather than crushed stone or for systems with drains that are farther apart. For systems where the subdrains are placed in very high conductivity materials such as crushed stone, a storage indication method coupled with an appropriate subdrain rating curve (Manning's Equation) might be sufficient for representing this

segment of flow. Manning's Equation also offers more flexibility in estimating the change in flow for small changes in water depth in the system.

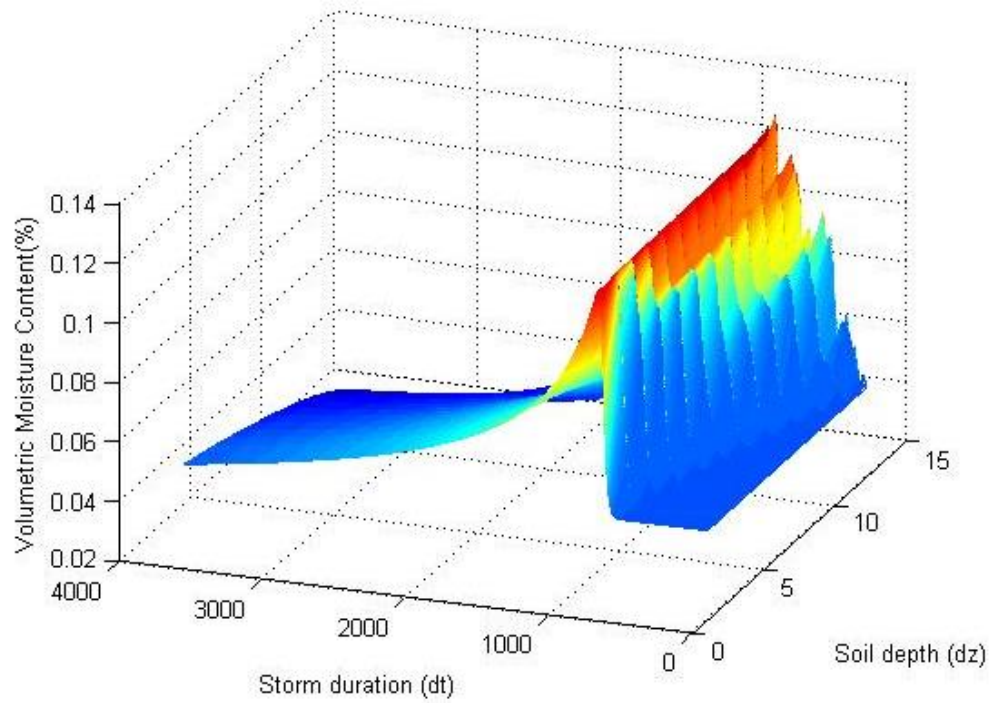

Figure 32 – Moisture content fluctuation in the filter media in response to the 07/23/2009 storm event ($dt = 1$ min, $dz = 2.5$ cm (1")). Saturation occurs at 27%.

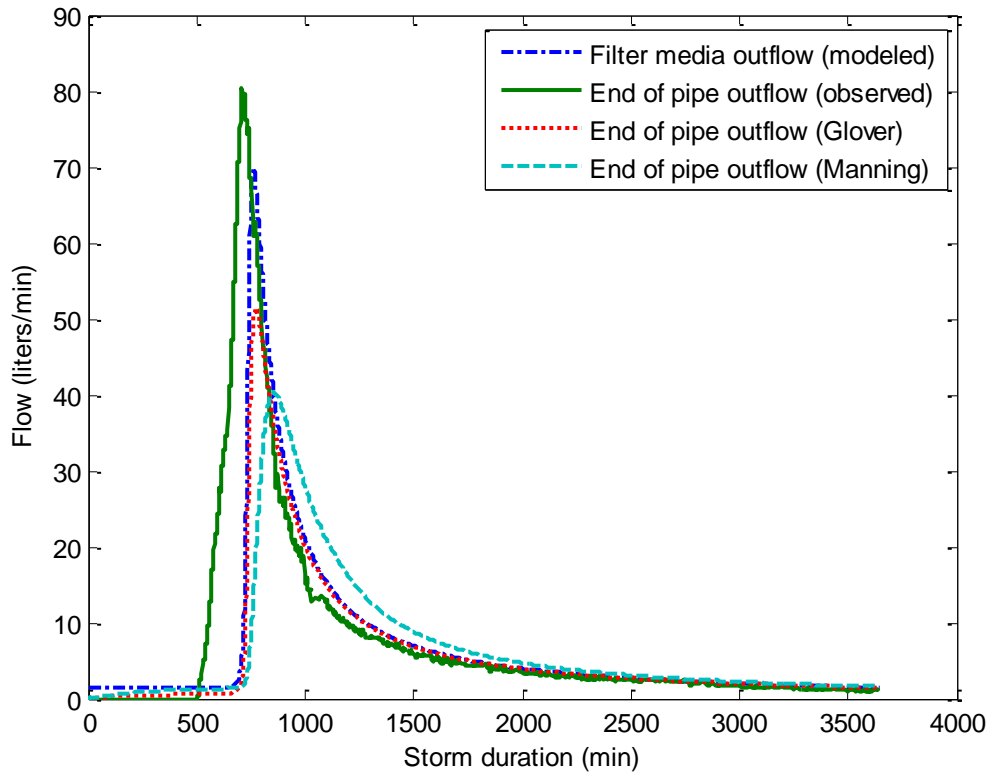

Figure 33 – Observed outflow hydrograph as compared to the modeled outflow for the West Edge system computed with Glover and Manning Equations for subdrains, and with Richards’ Equation as draining at the bottom of the filter media

Hydrograph’s volume

A closer look at the total storm volumes (Table 16) shows that for the storms in June and July 2009, the observed outflow volume is higher than the total amount of precipitation fallen on the surface of the pavement. This suggests that groundwater was entering the base of the system during the storm events and draining thorough the system’s sub drains. For other storms, the outflow volumes were lower than the total volume of precipitation, suggesting that the water level in the system was slightly below

the drain's invert, reduction in the overall volumes of "run-off" taking place in the system. Due to the imprecision of the monitored outflow volumes, the prediction ability of the overall volume of this model could not be verified. However, when the predicted volumes with Glover and Manning Equations were compared with the precipitation volume, the agreement was considerably closer (Table 16), which verifies that overall the model conserves the mass while routing precipitation through the system.

Although generally the modeled outflow volume was under predicted both with Manning and Glover equations, the opposite was true for the 08/21/2009, 08/28/2009 and 09/11/2009 events: the modeled hydrograph volumes were larger than the observed volumes. This suggests that there was some storage available below the drains at the beginning of these storms. The rating curve for the drains developed with Manning Equation was adjusted to account for storage, and it was found that the systems had 2.5, 2, and 2.75 cm, respectively of available storage under the drain's invert at the beginning of the three storm events. Figures of the generated hydrographs for these storms are presented in Appendix K, and storm volumes are shown in Table 16.

Table 16 – Total stormwater volumes computed as the cumulative area under hydrographs generated at the bottom of the filter media, and at the end of the pipe (Glover Equation). These are compared with the total volume observed at the end of the subdrain, and total precipitation fallen on the pavement surface.

Storm event	Modeled	Modeled	Modeled	Observed	Observed	Observed
	- end of the pipe (Glover) (liters)	- end of the pipe (Manning) (liters)	- filter media outflow (liters)	- end of the pipe (liters)	- Rainfall volume (liters)	- Rainfall depth (cm)
06/11/2009	25,145	25,481	27,979	17,170	26,152	5.03
06/18/2009	22,820	25,469	25,646	43,530	22,454	4.32
07/02/2009	17,080	17,000	13,119	30,937	16,246	1.78
07/07/2009	10,059	12,659	12,675	18,616	9,245	3.12
07/23/2009	21,902	24,340	24,725	28,270	23,642	4.55
08/21/2009	8,612	4,129	11,156	6,085	10,434	2.01
08/28/2009	19,457	13,836	22,267	11,326	22,982	4.42
09/11/2009	12,472	12,680	15,172	4,703	12,416	2.39

IV.3.4 Design variables effects on lag time through the filter media

It is generally recognized that runoff volumes can be reduced by infiltration losses and evapotranspiration; equations and modeling techniques for these losses are available and can be integrated in urban hydrology software.

The main way that hydrographs are transformed by routing through the filter media of PP systems is the attenuation of the peak flows through diffusion in the soils via unsaturated flow, as only minor losses can take place as the water evaporates or is retained in that layer after the precipitation ceases. The effect of the filter media on the lag time of the hydrographs is further analyzed.

Filter media thickness effects on lag time

The lag time contribution by different filter media thicknesses and permeability rates were further analyzed in response to a 2.5 cm Type II – SCS design storm. The lag times through the filter media were computed as the time difference between when the peak intensity of the precipitation event and the peak moisture content value recorded at the bottom of the filter media layer occurred. Several scenarios were analyzed by varying the thickness of the filter media from 15 cm (6”) to 61 cm (24”), as presented in Figure 34. The result of these simulations indicated that the lag time of the peak flow values in the filter media increase as the filter media thickness increases and follows a power relationship (Figure 35):

$$Lag\ time = 0.1061 * D^{1.9527}$$

Equation 23

Where:

Lag Time = the time difference between the precipitation peak intensity and peak flow occurring at the bottom of the filter media (minutes); *D* = the thickness of the filter media (cm).

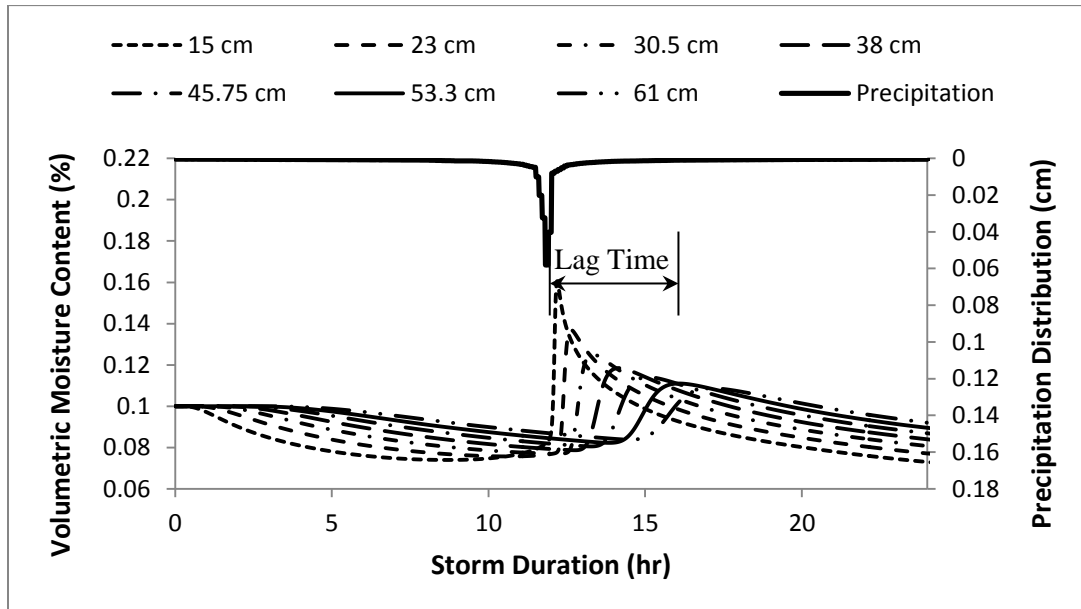

Figure 34 – The peak moisture content at the bottom of the filter media layer for various thicknesses, in response to a 2.5 cm Type II – SCS design storm

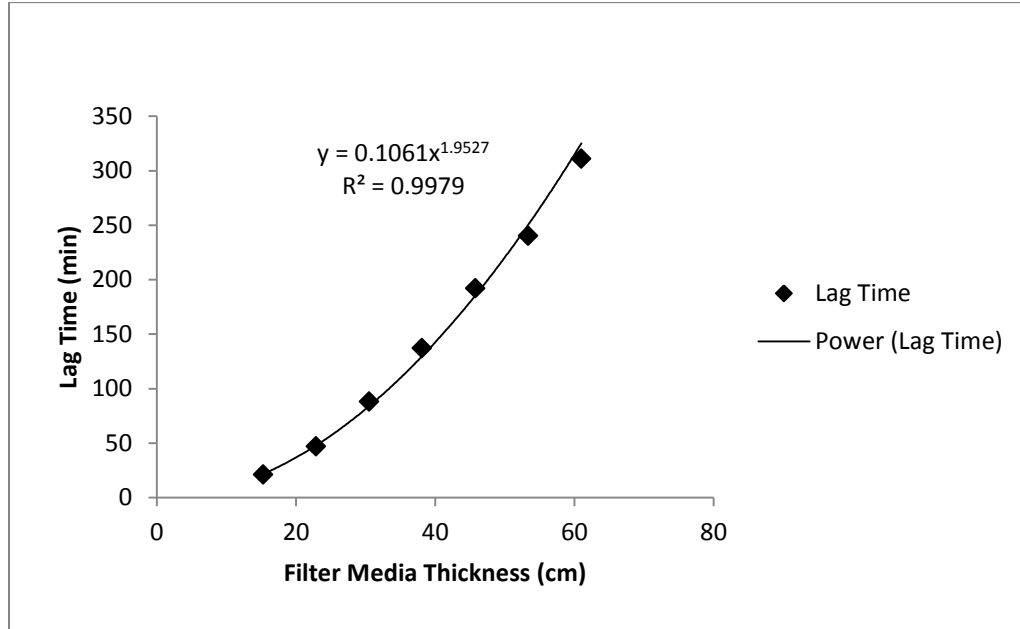

Figure 35 – Peak flow lag times of as a function of the filter media thicknesses

Filter media's K_{sat} effects on lag time

Although the flow in the filter media takes place under unsaturated conditions and the analysis is performed with unsaturated flow functions, the relative hydraulic conductivity function, $K_r(\theta)$, is scaled by the magnitude of K_{sat} . The effect of filter media's K_{sat} on the lag time through a 30 cm (12") filter media layer was analyzed under a 2.5 cm SCS-Type II design storm. The fluctuation of the VMC is presented in Figure 36. The relationship between the lag time and K_{sat} also followed a power function (Equation 24), the lag time decreasing as K_{sat} increases (Figure 37):

$$Lag\ time = 103.33 * K_{sat}^{-0.29}$$

Equation 24

Where:

Lag Time = the time difference between the precipitation peak intensity and peak flow occurring at the bottom of the filter media (minutes); K_{sat} = hydraulic conductivity at saturation (cm/min)

By combining the two sets of analysis, a family of curves was developed for estimating the lag times of peak flows caused by routing stormwater through filter media with various thicknesses and hydraulic conductivities (Figure 38). The coefficients for the general power functions describing each curve are presented in Table 17:

$$Lag\ time = a * K_{sat}^b$$

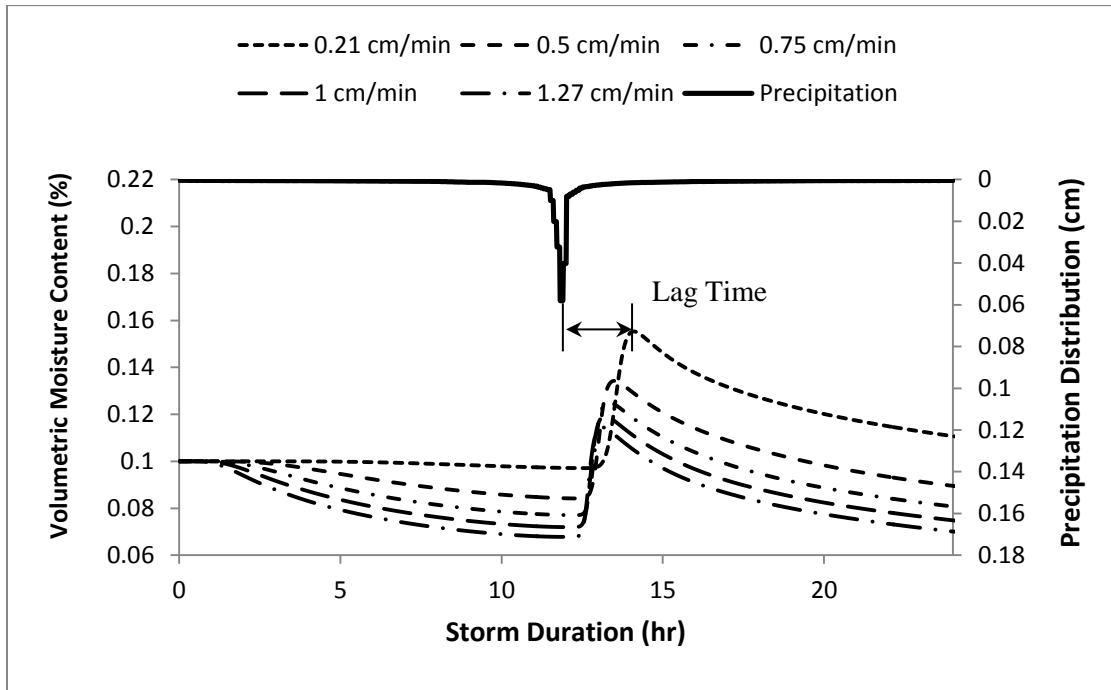

Figure 36 – The peak moisture content at the bottom of a 30 cm filter media layer for various filter media saturated hydraulic conductivities, in response to a 2.5 cm Type II – SCS design storm

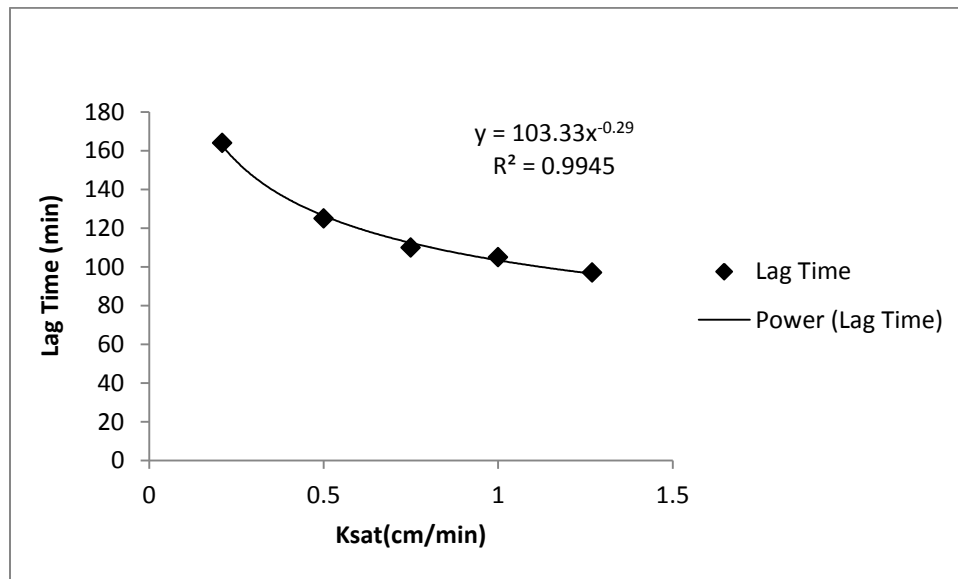

Figure 37 – Peak flow lag times for varying filter media K_{sat} in response to a 2.5 cm Type II – SCS design storm

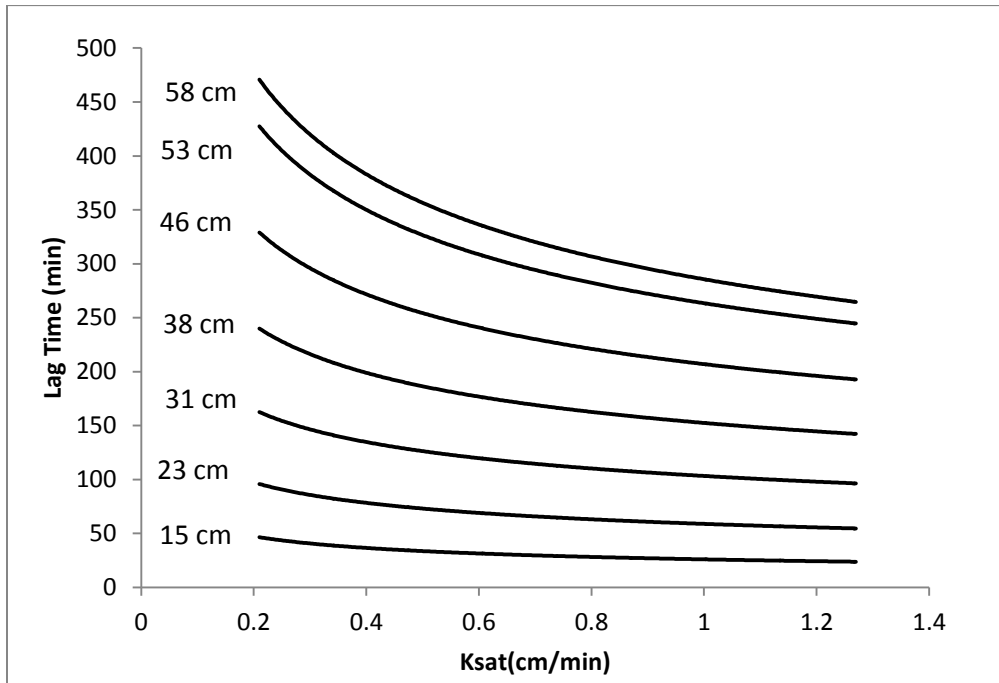

Figure 38 – Lag time through the filter media for permeable pavement systems with various thicknesses and hydraulic conductivities

Table 17 – The power function coefficients for the family of curves presented in Figure 38.

Filter media thickness (cm)	a (-)	b (-)	r ² (-)
15	26.01	-0.373	0.998
23	58.89	-0.312	0.994
31	103.33	-0.290	0.995
38	152.49	-0.290	0.997
46	207.00	-0.297	0.993
53	263.48	-0.310	0.992
59	285.69	-0.320	0.986

IV.4 Conclusions

This article presents a detailed, physically-based mathematical model for evaluating the hydrological behavior of PP systems. The proposed empirical equations relate the various design parameters of the system to the final outflow hydrograph of the system underdrains. Since most hydrologic software packages have good hydraulic capabilities to represent the drainage and geometry of the system, central attention was given to the testing of a framework for developing the θ - ψ - K_r relationship needed to solve Richards' Equation for the soils used as the filter media in PP systems. This framework started with easily accessible soil properties information. The water routing through the filter media module performed with good results when tested on two different PP systems.

CHAPTER V

Summary and Conclusions

The focus of this dissertation was the physical modeling of filtration LID-SWM systems. Simulating flow through these systems requires that models incorporate both hydraulic and hydrologic modeling capabilities in the same modeling module. Existing software packages used for sizing and designing of stormwater treatment systems do not have adequate capabilities to physically simulate the flow through the permeable layers of LID-SWM systems. However, they do have good capabilities of representing basic hydraulics of the systems (such as storage and piping networks; some continuous simulation models can also represent losses through evapotranspiration and infiltration). This dissertation focused on developing physically based models for simulating flow routing through filter media of LID systems that can be incorporated in both continuous simulation and design-storm approach software packages.

Chapter 2 presented a monitoring study of the moisture profile in the filter media of a permeable pavement system which revealed that this soil layer does not reach saturation. Based on this monitoring study, unsaturated flow equations are recommended for simulating flow through the filter media layer of permeable pavement systems. Although other filtration LID- SWM systems such as gravel wetlands, subsurface sand filters, and bioretention systems are designed to function under ponding conditions, which suggest saturation of the soils at least for extreme storm events. These systems transition from saturated to unsaturated flow between storm events and may function

under unsaturated conditions for small storms. Continuous simulation models for these systems would require capabilities to represent both saturated and unsaturated flow conditions, and the ability to switch from one to another as needed.

Since equations describing saturated flow conditions are well known and easily accessible, this study further addressed the modeling of unsaturated flow conditions for engineered LID-SWM systems filter media. In Chapter 3, a framework for obtaining the moisture retention curves and unsaturated hydraulic conductivity curves needed to solve unsaturated flow equations was developed. The goal of this framework was to compute these relationships starting with readily accessible soil data such as porosity and particle size distribution. This framework was developed for the filter media typically used in four common LID systems: permeable pavement, sand filter, bioretention, and subsurface gravel wetland. This framework performed well when tested against laboratory measurements of these relationships. Since it was developed with physical equations that took into account the detailed particle size distributions of the soils and engineered permeable media, this methodology is applicable to other mix variations of filter media soils.

The ability of the moisture retention curves and relative hydraulic conductivity characteristics developed with the framework described in Chapter 3 used in conjunction with Richards' Equation to replicate the moisture profiles in the filter media of the permeable pavement monitored in Chapter 2 were tested with good results. This sequence of equations used for simulating flow through the filter media was integrated and tested in a full permeable pavement system model, along with other physically-based equations,

as detailed in Chapter 4. For this model, simulated hydrographs at the end of the system's subdrains were compared with real time monitored flow data.

This dissertation presented a detailed methodology on modeling flow through a complex permeable pavement system using a series of physically-based equations. The routing through the filter media modeling routine described in Chapters 3 and 4 was developed to be integrated in continuous simulation models. Combining this flow routine with the basic hydraulic modeling capabilities of most stormwater system design software (such as storage and outlet structures hydraulics) would create a full physically-based model for simulating flow through permeable pavement systems. Such a model relates the physical properties of the filter media soils and the system's geometry to the final outflow hydrograph and would allow for easy optimization of the system's configuration to obtain targeted hydrographs. The simplified equations that relate the thickness and hydraulic conductivity of the filter media to the lag time of stormwater passing through this layer detailed in Chapter 4 were developed to be used with design-storm approach software packages. Routing through the restrictive soil layers of LID systems only affects the lag time and the overall water residence time in the system; this does not directly affect the total volume of the storm. Volume reduction takes place through losses such as evapotranspiration and infiltration in the native soils. Accurate representation of the lag time and residence time in the system would consequently lead to more accurate representation of volume reduction caused by routing stormwater through permeable pavement systems.

The unsaturated flow function framework presented in Chapter 3 and the physically-based methodology for the permeable pavement system presented in Chapter 4 could be further developed to accommodate other LID SWM systems that are designed to function temporarily under saturated conditions (subsurface gravel wetland, sand filter, bioretention system, and other variations of these systems). This can be accomplished by allowing the unsaturated flow model to switch to a saturated flow routine as needed. Simplified equations that relate the lag time to the thickness of the filter media and hydraulic conductivities for these systems can then be developed.

References

Aad, M. P. A., Suidan, M. T., & Shuster, W. D. (2009). Modeling techniques of best management practices: rain barrels and rain gardens using EPA SWMM-5. *Journal of Hydrologic Engineering*, 15(6), 434-443.

American Concrete Institute (ACI) (2006). *Pervious Concrete*. ACI 522R-06, Detroit.

Arya, L. M., & Paris, J. F. (1981). A physicoempirical model to predict the soil moisture characteristic from particle-size distribution and bulk density data. *Soil Science Society of America Journal*, 45(6), 1023-1030.

Arya, L. M., Leij, F. J., van Genuchten, M. T., & Shouse, P. J. (1999). Scaling parameter to predict the soil water characteristic from particle-size distribution data. *Soil Science Society of America Journal*, 63(3), 510-519.

ASTM D2434, (2006). Standard Test Method for Permeability of Granular Soils (Constant Head). *Annual Book of ASTM Standard*, Vol. 04.09, ASTM International, West Conshohocken, PA.

ASTM D422-63, (2007). Standard Test Method for Particle-Size Analysis of Soils. *Annual Book of ASTM Standard*, Vol. 04.08, ASTM International, West Conshohocken, PA.

ASTM D6836 (2008). Standard Test Methods for Determination of the Soil Water Characteristic Curve for Desorption Using a Hanging Column, Pressure Head Extractor, Chilled Mirror Hygrometer, and/or Centrifuge. *Annual Book of ASTM Standard*, Vol. 04.09, ASTM International, West Conshohocken, PA.

ASTM D7263 (2009). Standard Test Method for Laboratory Determination of Density (unit Weight) of Soil Specimens. *Annual Book of ASTM Standard*, Vol. 04.09, ASTM International, West Conshohocken, PA.

Bagarello, V., & Iovino, M. (2007). Comments on “Predicting the effect of rock fragments on saturated soil hydraulic conductivity”. *Soil Science Society of America Journal*, 71(5), 1584-1584.

Barbu I., Ballesterro T., Roseen R. (2009): Hydrological Response of SWM-LID Practices and Their Abilities of Mitigating Climate Change Impacts, ASCE Conf. Proc.

Barbu, I.A., Ballesterro, T.P., (2013a). The investigation of the nature of flow in a permeable pavement system. To be submitted to ASCE J. Hydraulics: May, 2013.

Barbu, I.A., Ballesterro, T.P., (2013b). Unsaturated Flow Functions for Filter Media used in Low Impact Development - Stormwater Management Systems. To be submitted to Soil Science Society America Journal: April, 2013.

Baver, L.D., Gardner, W.H., and Gardner, W.R. (1972). *Soil Physics*. New York: John Wiley & Sons.

Braga, A., Horst, M., and Traver, R.G. (2007). Temperature effects on the infiltration rate through an infiltration basin BMP. *J. Irrig. Drain. Eng.*, 133(6), 593-601.

Brakensiek, D. L., Rawls, W. J., & Stephenson, G. R. (1986). Determining the saturated hydraulic conductivity of a soil containing rock fragments. *Soil Science Society of America Journal*, 50(3), 834-835.

Boving, T., M. Stolt, and J. Augenstern, (2006). Investigation of the University of Rhode Island, Kingston, RI, porous pavement parking lot and its impact on subsurface water quality. University of Rhode Island. Kingston, University of Rhode Island.

Bouwer, H., & Rice, R. C. (1984). Hydraulic Properties of Stony Vadose Zones. *Groundwater*, 22(6).

Brooks, R.H., and Corey, A.T., 1966. Properties of porous media affecting fluid flow. *J. Irrig. Drain. Div. Am. Soc. Civil. Eng.* 92, 61-88.

Browne, D., Deletic, A., Mudd, G. M., & Fletcher, T. D. (2008). A new saturated/unsaturated model for stormwater infiltration systems. *Hydrological Processes*, 22(25), 4838-4849.

Burdine, N. T. (1953). Relative permeability calculations from pore size distribution data. *Journal of Petroleum Technology*, 5(3), 71-78.

Carpenter, D. D., & Hallam, L. (2009). Influence of planting soil mix characteristics on bioretention cell design and performance. *Journal of Hydrologic Engineering*, 15(6), 404-416.

Childs, E.C. and Collis-George, N. 1950. The permeability of porous materials. *Proc. R. Soc. London A201*: 392-405.

Claytor, R. A., Schueler, T. R. (1996). Design of stormwater filtering systems. Chesapeake Research Consortium.

Dane, J.H., and Topp, G.C. 2002. *Methods of Soil Analysis. Part 4. Physical Methods.* SSSA Book Ser. 5 SSSA, Madison, WI.

Darcy, H. P. G. (1856). Dètermination des lois d'écoulement de l'eau à travers le sable.

Decagon Devices, (2011). Calibration Equations for the ECH2O EC-5, ECH2O-TE and 5TE Sensors. Retrieved on August 9, 2012 from <http://www.decagon.com>.

Dempsey, B. A., and D.M. Swisher (2003). Evaluation of porous pavement and infiltration in Centre County, PA. World Water & Environmental Resources Congress 2003 and Related Symposia.

Dietz, M. (2007). Low Impact Development Practices: A Review of Current Research and Recommendations for Future Directions. *Water, Air, and Soil Pollution* (2007) 186:351–363.

Dussailant, A., Cozzetto, K., Brander, K., & Potter, K. (2003). Green-Ampt model of a rain garden and comparison to Richards equation model. *SUSTAINABLE PLANNING & DEVELOPMENT.*, 891-900.

Dussailant, A. R., Wu, C. H., & Potter, K. W. (2004). Richards equation model of a rain garden. *Journal of Hydrologic Engineering*, 9(3), 219-225.

Elliott A.H., and Trowsdale S.A. (2006). A review of models for low impact urban stormwater drainage. *Environmental Modeling & Software* 22, 394-405.

Ferguson, B. (2005). Porous Pavements, Integrative studies in Water Management and Land Development.

Ferguson, B. K. (1998). Introduction to stormwater: concept, purpose, design. John Wiley & Sons.

Fetter, C. W. (1988). Applied Hydrogeology. Merrill Publishing Co., Columbus Ohio. 1988. 592.

Fredlund, M. D., Wilson, G. W., & Fredlund, D. G. (2002). Use of the grain-size distribution for estimation of the soil-water characteristic curve. *Canadian Geotechnical Journal*, 39(5), 1103-1117.

Gallage, C., & Uchimura, T. (2010). Effects of dry density and grain size distribution on soil-water characteristic curves of sandy soils. *Soils and Foundations*, 50(1), 161-172.

Gardner, W. R. (1958). Some steady-state solutions of the unsaturated moisture flow equation with application to evaporation from a water table. *Soil science*, 85(4), 228-232.

Gribb, M. M., Forkutsa, I., Hansen, A., Chandler, D. G., & McNamara, J. P. (2009). The effect of various soil hydraulic property estimates on soil moisture simulations. *Vadose Zone Journal*, 8(2), 321-331.

Glover, R. E. (1974). *Transient ground water hydraulics*. Department of Civil Engineering, College of Engineering, Colorado State University.

Haverkamp, R., Zammit, C., Boubkraoui, F., Rajkai, K., Arrúe, J. L., & Heckmann, N. (1997). GRIZZLY, Grenoble Soil Catalogue: Soil survey of field data and description of particle size, soil water retention and hydraulic conductivity functions. *Laboratoire d'Etude des Transferts en Hydrologie et Environnement (LTHE)*, Grenoble Cedex, 9.

Hooghoudt, S. B. (1940). "Bijdrage tot de kennis van eenige natuurkundige grootheden van den grond No. 7." *Algemeene beschouwingen van het probleem van de detailontwatering en de infiltratie door middel van parallel loopende drains, greppels, slooten en kanalen*, Departement van landbouw en visscherij, directie van de landbouw, Algemeene Staatsdrukkerij, The Hague, The Netherlands, *Verslagen van Landbouwkundige Onderzoekingen*, 46(14), 515–707 (in Dutch).

Houle, K. M. (2008). *Winter performance assessment of permeable pavements*. MS Thesis, University of New Hampshire, Durham, NH.

Houle, J., Roseen, R., Ballestero, T., Puls, T., and Sherrard, J. (2013). *A Comparison of Maintenance Cost, Labor Demands, and System Performance for LID and Conventional Stormwater Management*. *J. Environ. Eng.*

Jackson, T. J., & Ragan, R. M. (1974). Hydrology of porous pavement parking lots. *Journal of the Hydraulics Division*, 100(12), 1739-1752.

Jayasuriya, N., & Kadurupokune, N. (2008). *Impact of Pervious Pavements on Drainage Infrastructure*. *Proceedings of 11th ICUD, Melbourne, 31st of August to the 5th of September*.

Karathanasis, A. D., & Hajek, B. F. (1982). Quantitative evaluation of water adsorption on soil clays. *Soil Science Society of America Journal*, 46(6), 1321-1325.

Khaleel, R., & Relyea, J. F. (1997). Correcting laboratory-measured moisture retention data for gravels. *Water resources research*, 33(8), 1875-1878.

Krebs, R. D., & Walker, R. D. (1971). *Highway materials*. McGraw-Hill.

Kuang, X., Sansalone, J., Ying, G., & Ranieri, V. (2011). Pore-structure models of hydraulic conductivity for permeable pavement. *Journal of Hydrology*, 399(3), 148-157.

Ladd, T. C. (2004). Water quantity study of a porous concrete infiltration basin best management practice. PhD Thesis, Villanova University, Villanova, PA.

Lane, K. S., Washburn, D. E., & Krynine, D. P. (1947). Capillarity tests by capillarimeter and by soil filled tubes. In *Highway Research Board Proceedings* (Vol. 27).

Lee, R. S. (2011). Modeling infiltration in a stormwater control measure using modified Greem and Ampt. MS Thesis, Villanova University, Villanova, PA.

Leming, M. L., Malcom, H. R., & Tennis, P. D. (2007). *Hydrologic design of pervious concrete*. Portland Cement Association and National Ready Mixed Concrete Association, Silver Spring, MD.

Lucas, W. C. (2009). Design of integrated bioinfiltration-detention urban retrofits with design storm and continuous simulation methods. *Journal of Hydrologic Engineering*, 15(6), 486-498.

Manning, R., Griffith, J. P., Pigot, T. F., & Vernon-Harcourt, L. F. (1890). On the flow of water in open channels and pipes.

Marshall, T.J., and Holmes, J.W. (1979). *Soil Physics*. New York: Cambridge Univ. Press.

Milczarek, M. A., Zyl, D., Peng, S., & Rice, R. C. (2006, March). Saturated and Unsaturated Hydraulic Properties Characterization at Mine Facilities: Are We Doing it Right?. In *Int. Conf. on Acid Rock Drainage, 7th*, St. Louis, MO (pp. 26-30).

Mualem, Y. (1976). A New Model for Predicting the Hydraulic Conductivity of Unsaturated Porous Media. *Water Resources Research*, 12(3).

NOAA (2012). *Climate Information Library – National Weather Service Forecast Portland Grey Maine*. Retrieved December 14, 2012 from: http://www.erh.noaa.gov/er/gyx/climate_f6.shtml

Peck, A. J., & Watson, J. D. (1979,). Hydraulic conductivity and flow in non-uniform soil. In *Workshop on soil physics and field heterogeneity*. CSIRO Division of Environmental Mechanics, Canberra, Australia.

Richards, L.A. (1931). "Capillary conduction of liquids through porous mediums". *Physics 1* (5): 318–333.

Roseen, R.M., Ballesterro, T.P., Houle, J.J., Avelleneda, P., Wildey, R., & Briggs, J. (2006). Storm water low-impact development, conventional, structural, and manufactured treatment strategies for parking lot runoff: Performance evaluations under varied mass loading conditions. *Transportation Research Record: Journal of the Transportation Research Board*. No. 1984: 135-147.

Roseen, R.M., Ballesterro, T. P., Houle, J.J., Briggs, J. F., Houle, K. M. (2012). Water Quality and Hydrologic Performance of a Porous Asphalt Pavement as a Storm-Water Treatment Strategy in a Cold Climate. *J. of Environmental Engineering*, 138(1), 81-89.

- Rosenbaum, U., Huisman, J.A., Weuthen, A., Vereecken, H., Bogena, H.R., (2010). Sensor-to-Sensor Variability of the ECHO EC-5, TE, and 5TE Sensors in Dielectric Liquids, *Vadose Zone Journal*, (9): 181–186.
- Sansalone, J., Kuang, X., & Ranieri, V. (2008). Permeable pavement as a hydraulic and filtration interface for urban drainage. *Journal of irrigation and drainage engineering*, 134(5), 666-674.
- Sauer, T. J., Logsdon, S. D. (2002). Hydraulic and physical properties of stony soils in a small watershed. *Soil Science Society of America Journal*, 66(6), 1947-1956.
- Schwartz, S. S. (2010). Effective Curve Number and Hydrologic Design of Pervious Concrete Storm-Water Systems. *Journal of Hydrologic Engineering*, 15(6), 465-474.
- Stone, R. (2013). Evaluation and optimization of the effectiveness of stormwater control measures for nitrogen and phosphorus removal. MS Thesis, University of New Hampshire, Durham, NH.
- Topp, G. C., Davis, J. L., and Annan, A. P. (1980). Electromagnetic determination of soil water content: measurements in coaxial transmission lines, *Water Resources Research*, 16(3): 574-582.
- Tuteja, N. K., Vaze, J., Murphy, B., & Beale, G. (2004). CLASS: Catchment scale multiple -landuse atmosphere soil water and solute transport model. CRC for Catchment Hydrology.
- USEPA (2000). Low Impact Development (LID) – A literature review. Washington, DC. EPA-841-B-00-005
- USEPA, (2013). Detention/retention ponds – fact sheet. Retrieved from web March 2013): <http://cfpub.epa.gov/npdes/stormwater/menuofbmps/index.cfm>

University of New Hampshire Stormwater Center (UNHSC). (2009a). "UNHSC design specifications for porous asphalt pavement and infiltration beds." http://www.unh.edu/erg/cstev/pubs_specs_info.htm.

University of New Hampshire Stormwater Center (UNHSC), (2009b). Bi-annual Report - 2009. University of New Hampshire, Durham, NH.

University of New Hampshire Stormwater Center (UNHSC), (2012). Bi-annual Report - 2012. University of New Hampshire, Durham, NH.

Van Genuchten, M. T. (1980). A closed-form equation for predicting the hydraulic conductivity of unsaturated soils. *Soil Science Society of America Journal*, 44(5), 892-898.

Van Genuchten, M. T., Leij, F. J., & Yates, S. R. (1991). The RETC code for quantifying the hydraulic functions of unsaturated soils (pp. 2-91). EPA.

Vucovik, M., & Soro, A. (1992). Determination of hydraulic conductivity of porous media from grain-size composition. Water Resources Publications, Littleton, Colorado.

Weibull, W., (1939). The Phenomenon of Rupture in Solids: Ingeniors Vetenskaps Akademien Handlinga 153, Stockholm, p. 17.

Appendix A: Storm events inventory analyzed for the Alumni Lot study (Chapter II)

Rank	Storm date	Total Precipitation	Precipitation Duration	Residence time	Lag time Port1	Initial VMC- Port 2	Maximum VMC Port 2
	(-)	(cm)	(hr)	(days)	(hr)	(%)	(%)
1	11/04/10	3.10	25.83	2.94	2.00	11.9	14.2
2	11/07/10	2.54	17.42	1.29	1.92	12.7	14.3
3	11/16/10	3.25	12.00	3.13	2.42	12.3	14.4
4	11/26/10	0.89	8.25	3.01	3.25	12.7	13.6
5	12/01/10	1.60	3.92	1.42	0.25	12.2	13.7
6	12/11/10	4.67	43.75	5.68	0.58	11.1	13.1
7	12/07/10	1.19	32.08	3.89	2.67	10.9	10.9
9	01/21/11	0.81	8.50	N/A*	N/A*	4.7	4.7
10	01/26/11	0.66	7.83	1.33	1.50	4.4	4.4
11	02/01/11	1.55	37.50	2.72	3.42	4.4	4.4
12	02/05/11	1.17	7.50	3.64	0.42	4.4	4.5
13	02/25/11	2.34	13.08	1.09	0.50	5.7	5.8
14	02/28/11	1.42	4.08	N/A*	2.33	5.8	5.9
15	03/06/11	3.84	14.50	0.76	0.58	7.1	8.5
16	03/10/11	1.68	18.08	3.96	0.75	18.5	20.2
17	04/10/11	1.27	5.50	1.99	0.50	13.0	14.4
18	04/13/11	2.39	24.08	3.04	1.00	14.2	17.0
19	04/16/11	3.28	25.00	3.45	1.58	16.6	18.1
20	04/23/11	1.80	18.08	3.95	1.25	16.4	17.8
21	05/04/11	1.55	19.67	7.52	2.08	16.1	17.7
22	05/14/11	7.39	123.83	N/A*	1.92	15.7	17.1

23	06/11/11	2.82	21.42	2.88	4.08	16.5	17.8
24	06/22/11	4.01	65.58	6.88	5.67	16.1	17.6
25	07/13/11	0.51	25.50	4.60	9.83	14.3	15.9
26	07/28/11	0.66	5.50	3.48	1.33	14.1	15.6
27	07/29/11	4.60	75.75	4.07	6.42	14.1	16.2
28	08/15/11	4.98	31.42	6.00	5.42	14.5	16.0
29	08/25/11	0.66	10.92	1.71	4.00	15.0	16.0
30	08/27/11	6.17	24.00	2.31	5.58	15.3	16.6
31	09/06/11	4.22	53.67	2.97	4.83	14.7	16.3
32	09/22/11	0.99	23.50	1.57	2.00	14.5	15.8
33	09/23/11	1.78	12.42	2.30	1.50	15.3	16.1
34	09/29/11	1.30	15.58	3.02	2.25	14.6	16.2
35	10/02/11	5.21	60.42	3.88	0.33	15.0	16.2
36	10/13/11	3.10	39.75	5.17	2.50	14.6	16.1
37	10/19/11	3.18	25.58	3.76	2.25	14.9	16.5
38	10/24/11	2.44	31.50	N/A *	N/A *	15.0	15.0
39	10/27/11	1.65	23.33	0.52	N/A *	15.6	15.9
40	11/10/11	2.54	8.67	1.54	1.92	14.5	16.2
41	11/16/11	0.53	11.42	2.44	4.17	14.0	14.9
42	11/22/11	3.25	9.33	5.02	2.58	13.9	15.5
43	11/29/11	1.60	3.92	2.05	1.67	14.7	16.0
44	12/07/11	4.34	20.17	1.69	2.00	15.3	16.0
45	12/23/11	0.99	7.33	0.39	1.25	15.1	15.6
46	12/27/11	0.81	6.58	1.98	0.33	12.4	13.9

* - Data not available for this storm due to probe malfunctioning.

Appendix B: Design Precipitation – Durham, NH

Extreme Precipitation Estimates – Jan 2013, Northeast Regional Climate Forecasting Center (NERCC): <http://precip.eas.cornell.edu/>

	5min	10min	15min	30min	60min	120min	1hr	2hr	3hr	6hr	12hr	24hr	48hr	1day	2day	4day	7day	10day
1yr	0.26	0.40	0.50	0.65	0.81	1.03	0.70	0.98	1.20	1.55	2.00	2.61	2.84	2.31	2.73	3.13	3.85	4.43
2yr	0.32	0.49	0.61	0.81	1.01	1.29	0.88	1.17	1.50	1.91	2.44	3.13	3.47	2.77	3.34	3.84	4.57	5.20
5yr	0.37	0.57	0.72	0.96	1.23	1.58	1.06	1.44	1.85	2.38	3.07	3.97	4.45	3.51	4.28	4.89	5.78	6.54
10yr	0.40	0.63	0.80	1.09	1.42	1.84	1.22	1.69	2.18	2.82	3.66	4.74	5.37	4.20	5.17	5.88	6.91	7.78
25yr	0.46	0.74	0.94	1.29	1.72	2.27	1.48	2.09	2.69	3.52	4.61	6.01	6.90	5.32	6.63	7.51	8.75	9.80
50yr	0.51	0.83	1.06	1.48	1.99	2.66	1.72	2.46	3.17	4.18	5.49	7.19	8.34	6.37	8.02	9.04	10.47	11.68
100yr	0.58	0.93	1.20	1.70	2.31	3.12	2.00	2.89	3.74	4.96	6.54	8.62	10.08	7.62	9.69	10.88	12.54	13.92
200yr	0.64	1.04	1.35	1.94	2.69	3.66	2.32	3.40	4.42	5.89	7.81	10.32	12.19	9.13	11.72	13.10	15.02	16.60
500yr	0.75	1.24	1.61	2.34	3.28	4.52	2.83	4.21	5.48	7.38	9.86	13.11	15.67	11.60	15.07	16.75	19.07	20.97

**Appendix H: Storms used for the model calibration of the West Edge
PP system**

Storm Date	Precipitation (in)	Precipitation (cm)
06/11/2009	1.98	5.03
06/18/2009	1.7	4.32
07/02/2009	1.77	3.12
07/07/2009	0.7	1.78
07/23/2009	1.79	4.55
08/21/2009	0.79	2.01
08/28/2009	1.74	4.42
09/11/2009	0.94	2.39

**Appendix I: Storms used for the calibration of the Alumni Lot - filter
media model**

	Storm Date	Precipitation (in)	Precipitation (cm)
Calibration	11/04/2010	1.22	3.10
Storms	11/07/2010	1.00	2.54
	11/16/2010	1.28	3.25
Verification	11/26/2010	0.35	0.89
Storms	04/10/2011	0.50	1.27
	04/13/2011	0.94	2.38

Appendix J: Calibration storms for the filter media of the Alumni Lot

11/07/2010 Storm Event

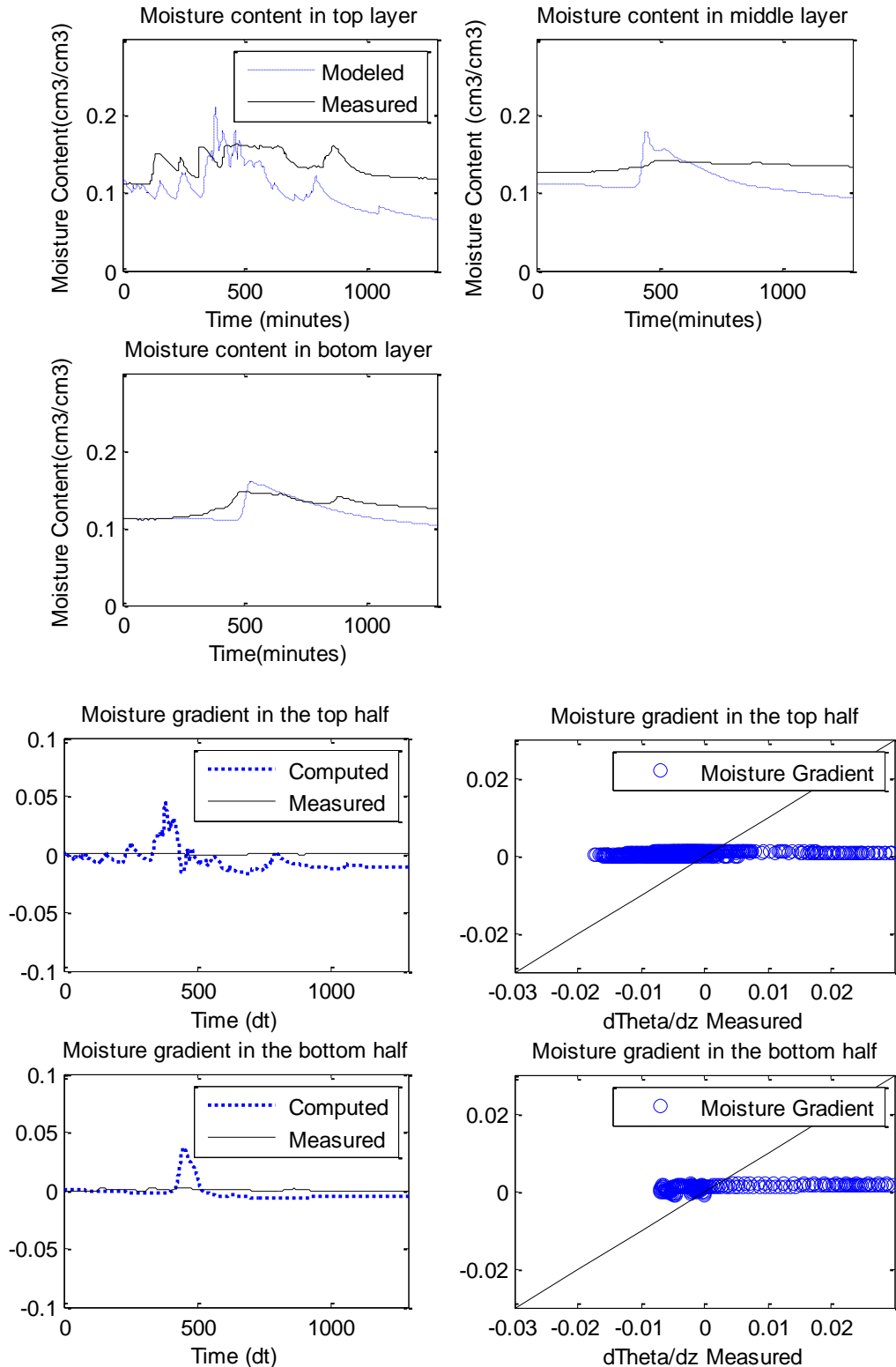

11/16/2010 Storm Event

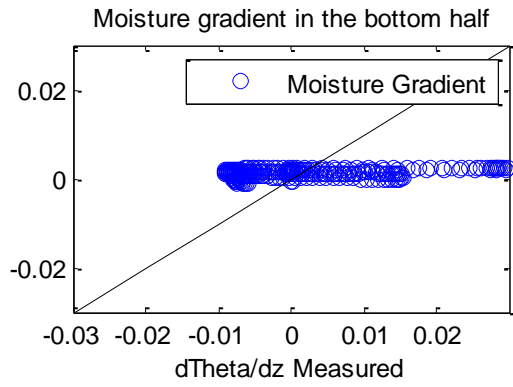
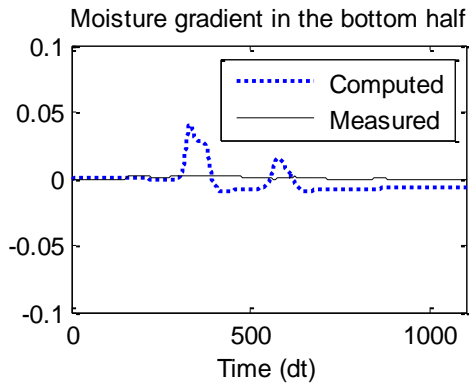
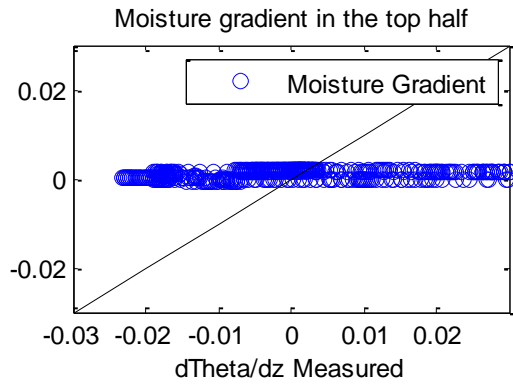
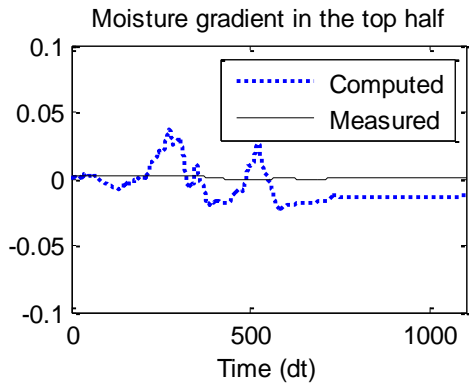
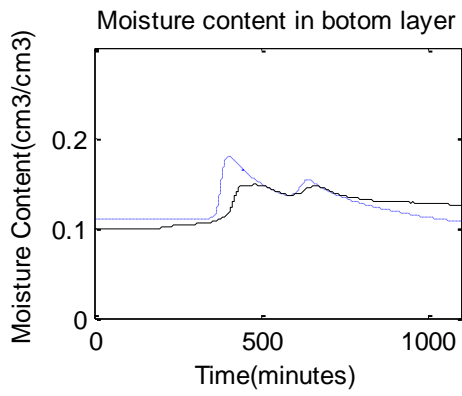
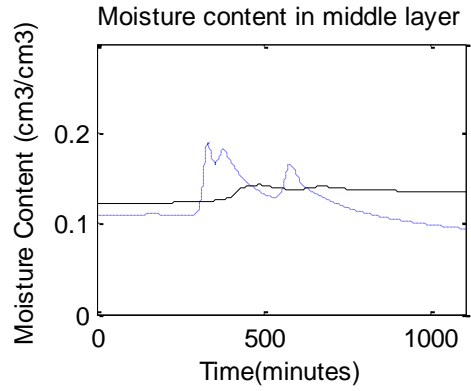
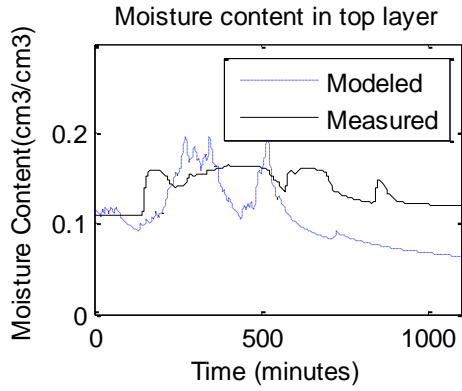

11/26/2010 Storm Event

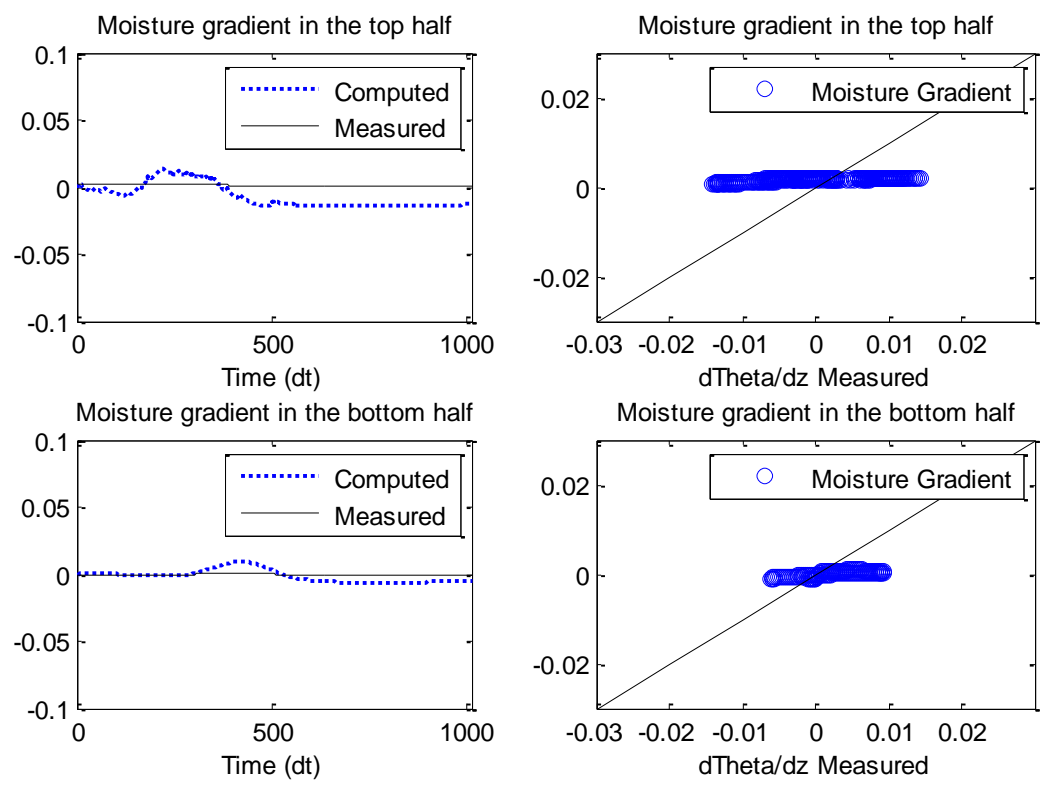
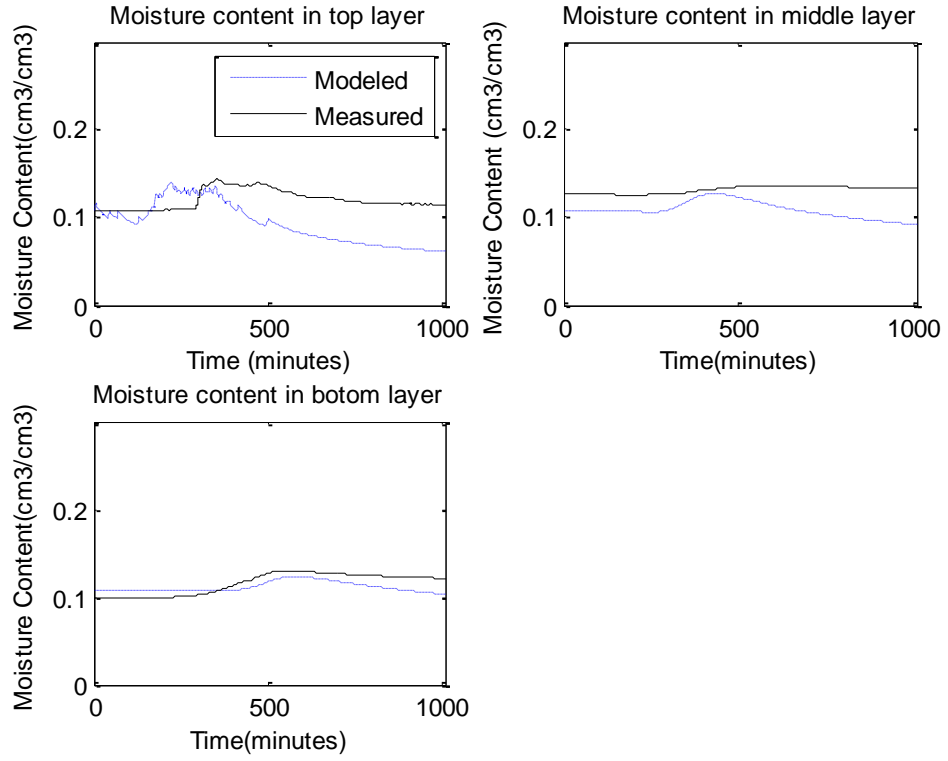

04/10/2011 Storm Event

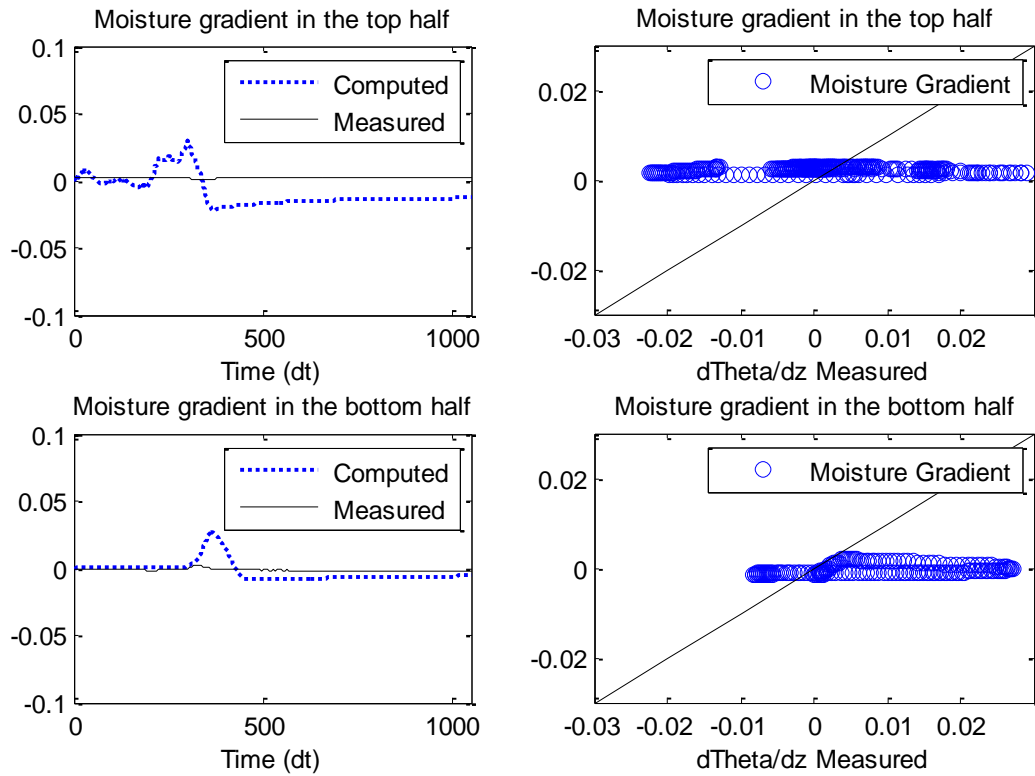
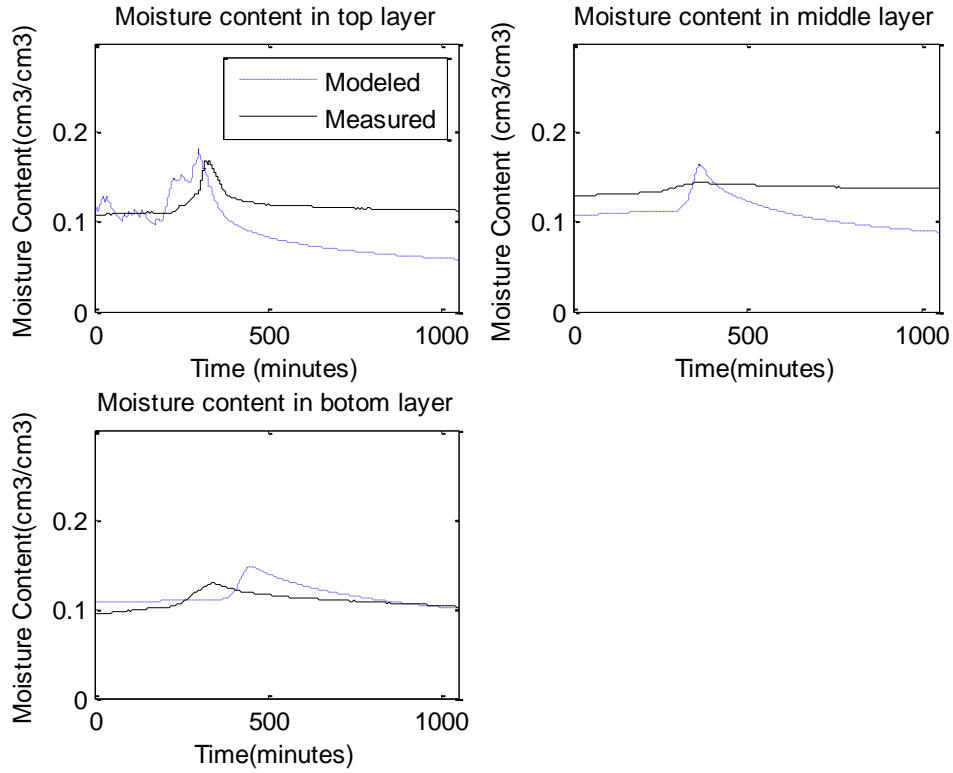

04/13/2011 Storm Event

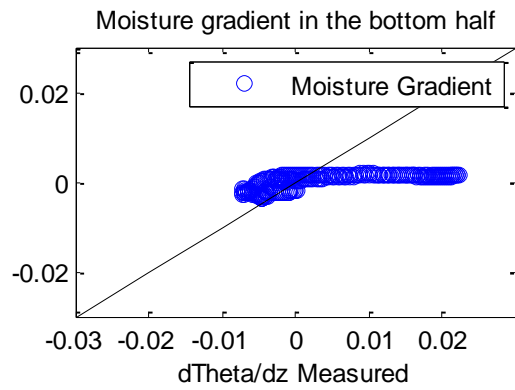
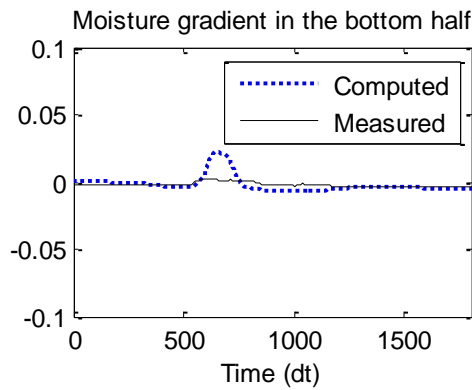
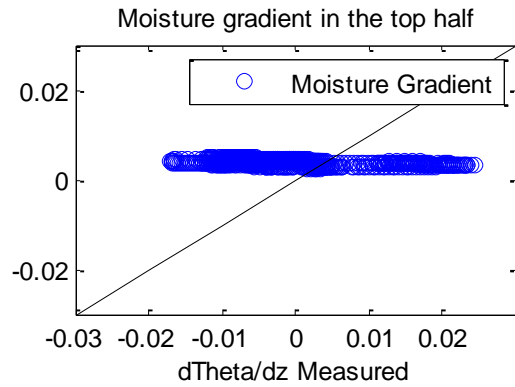
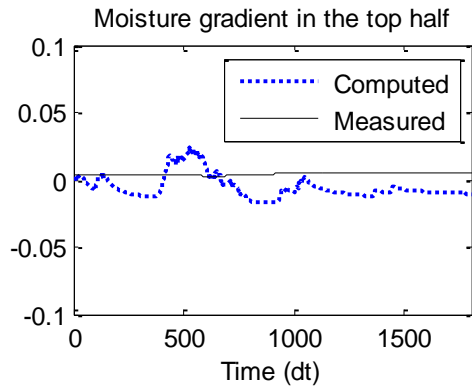
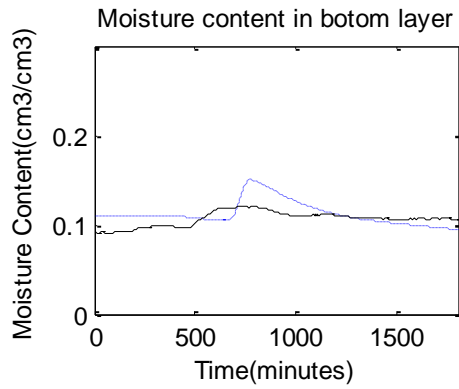
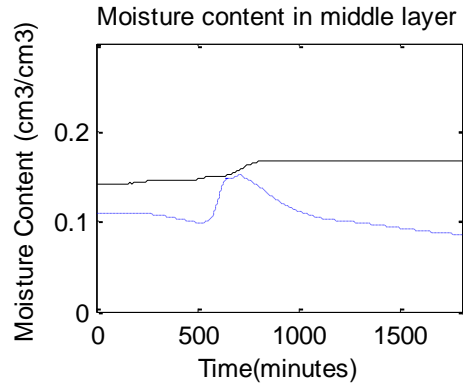
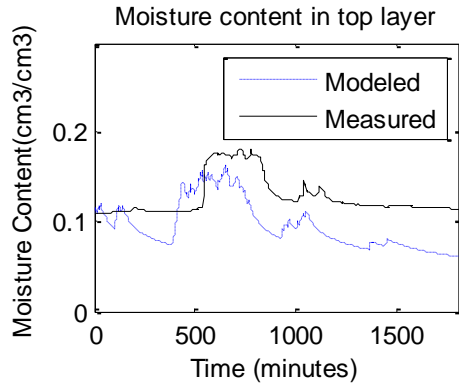

Appendix K: Testing storms for the West Edge PP model

06/11/2009 Storm Event

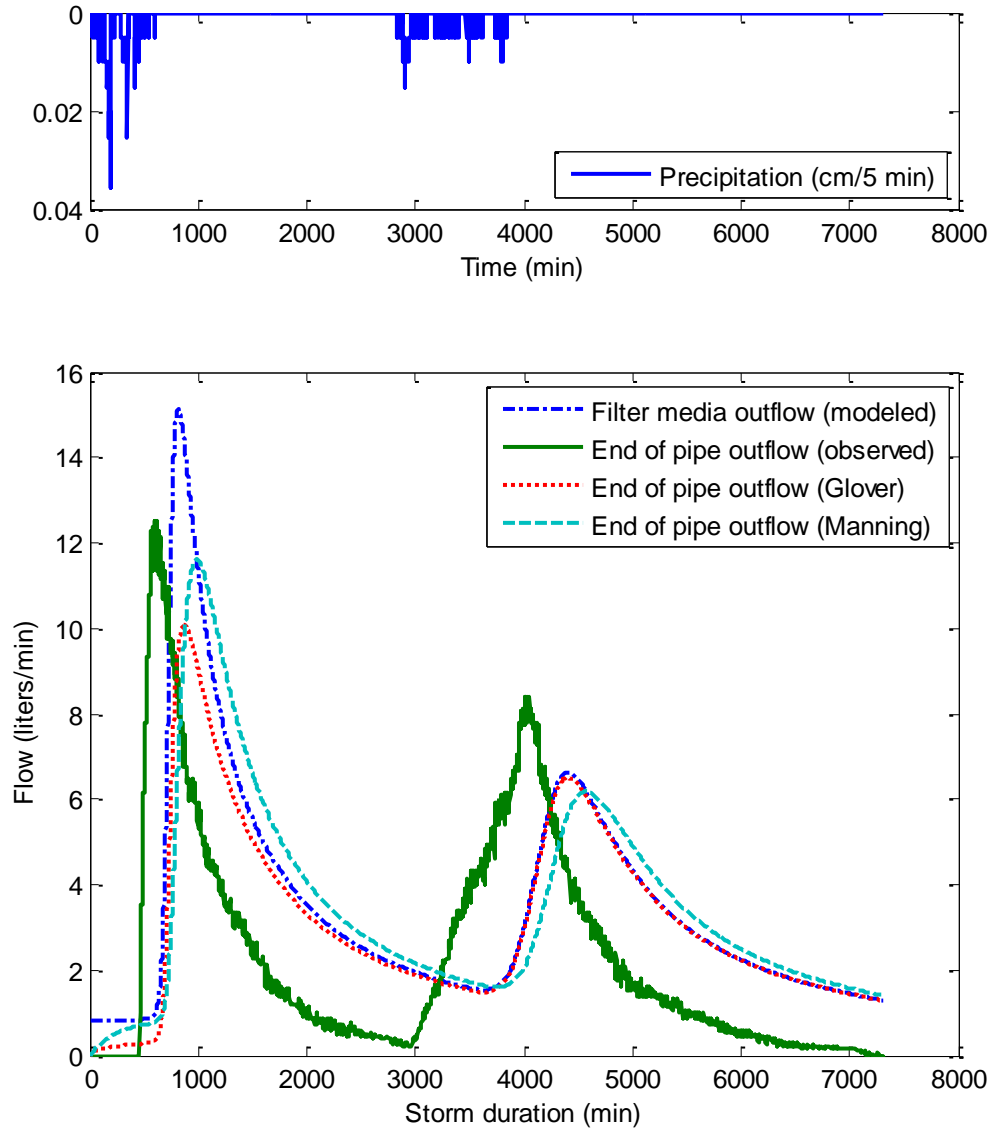

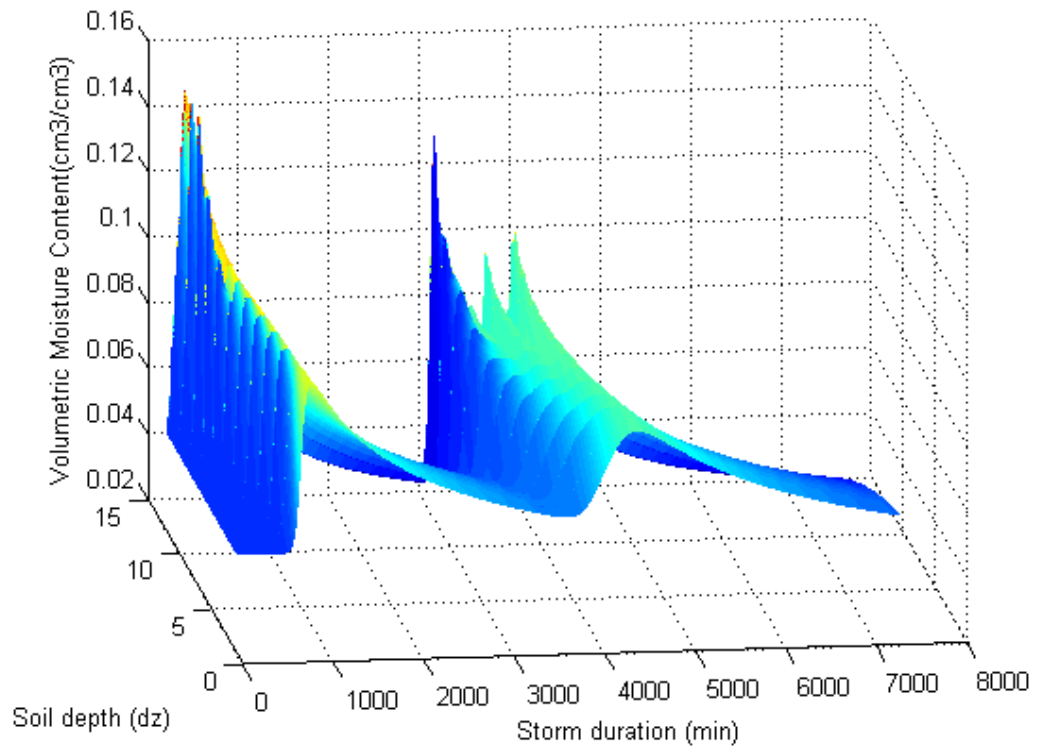

06/18/2009 Storm Event

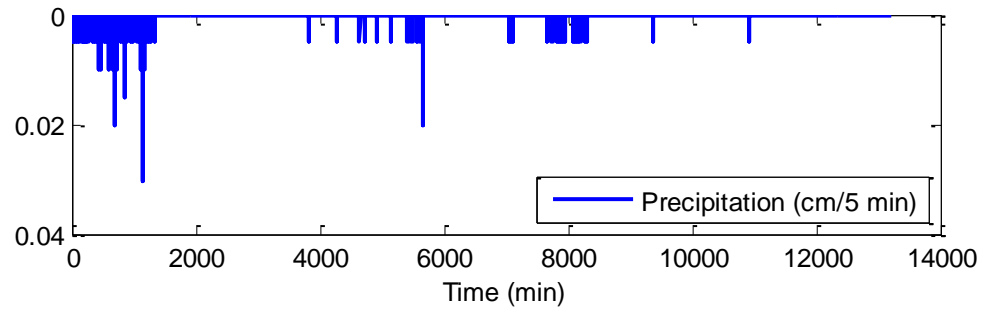

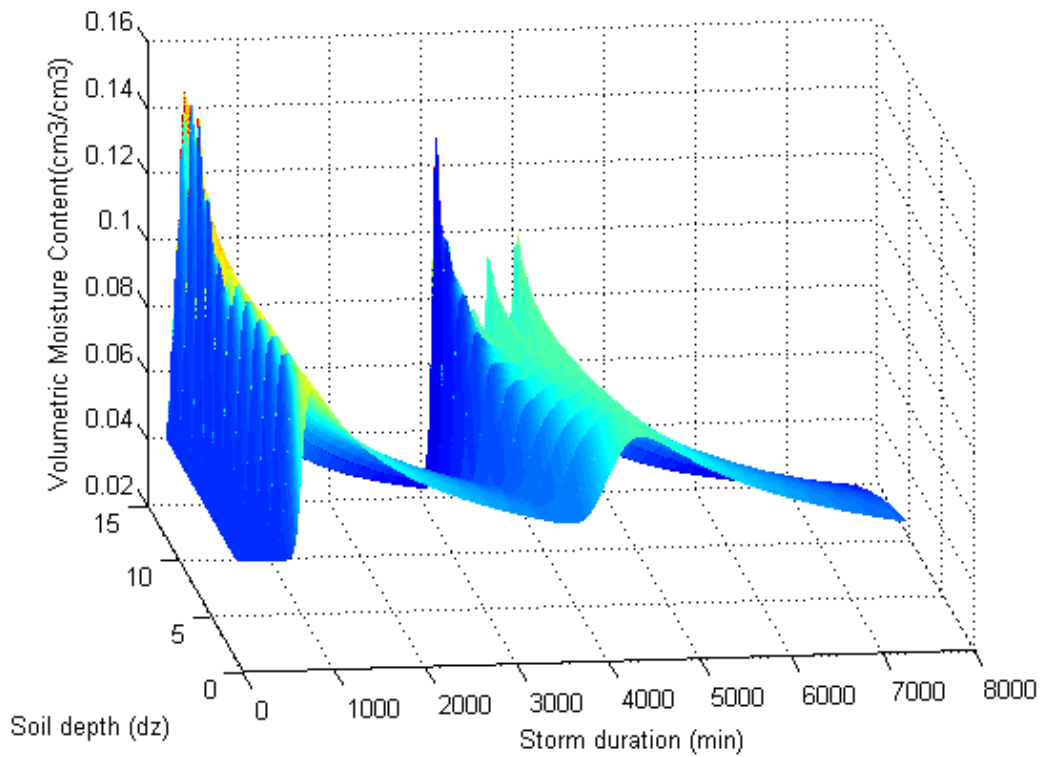
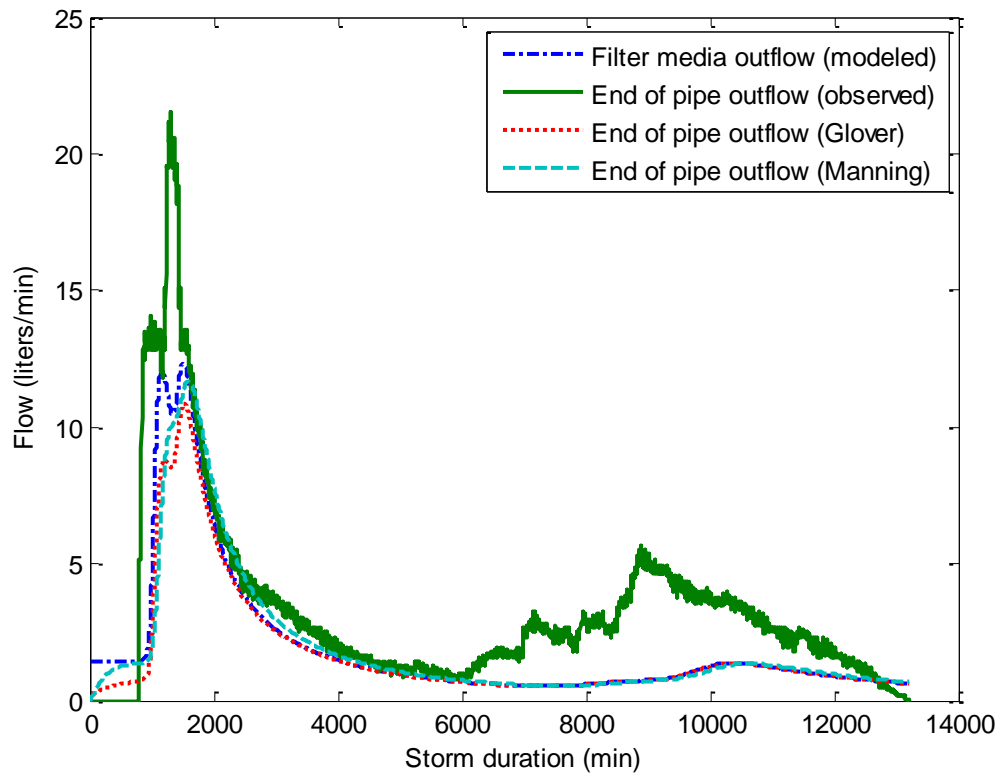

07/02/2009 Storm Event

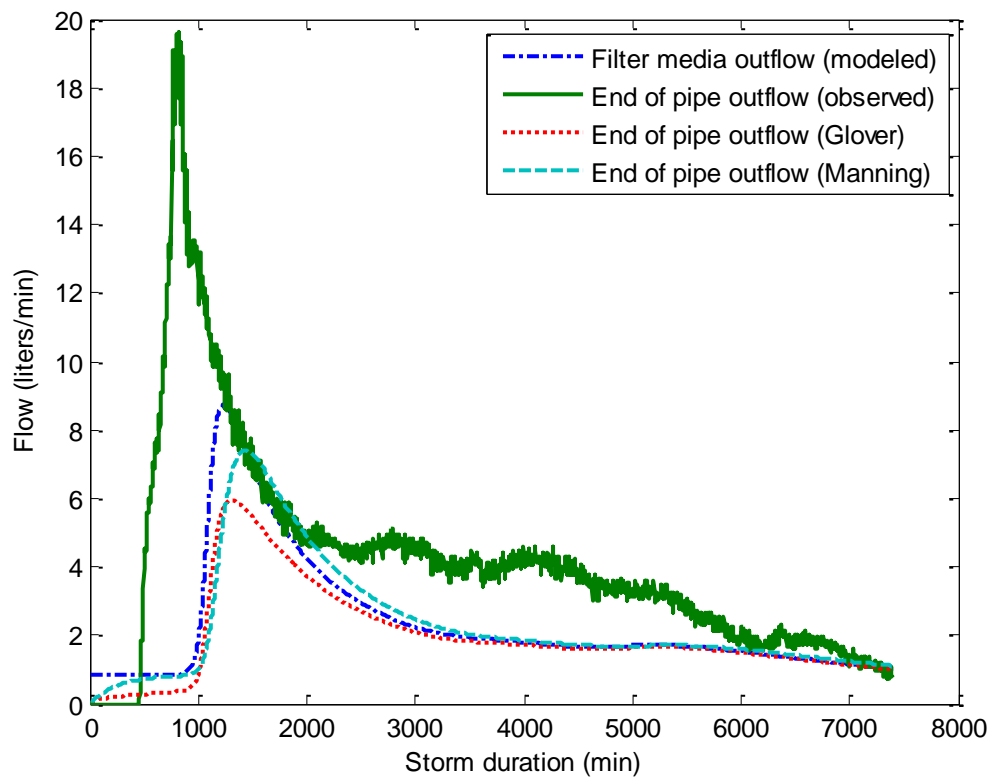
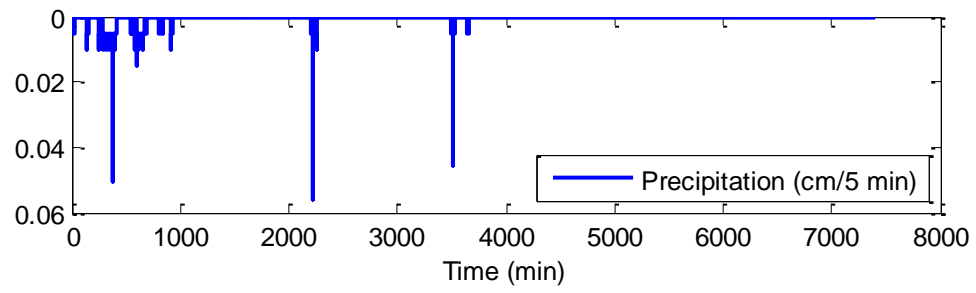

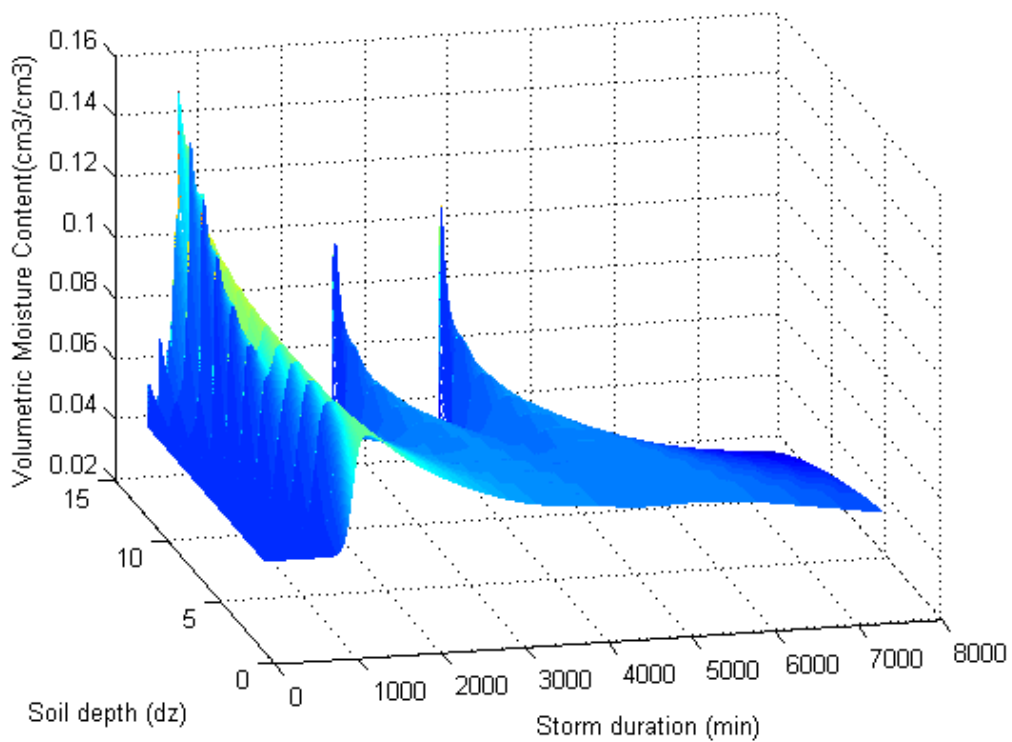

07/07/2009 Storm Event

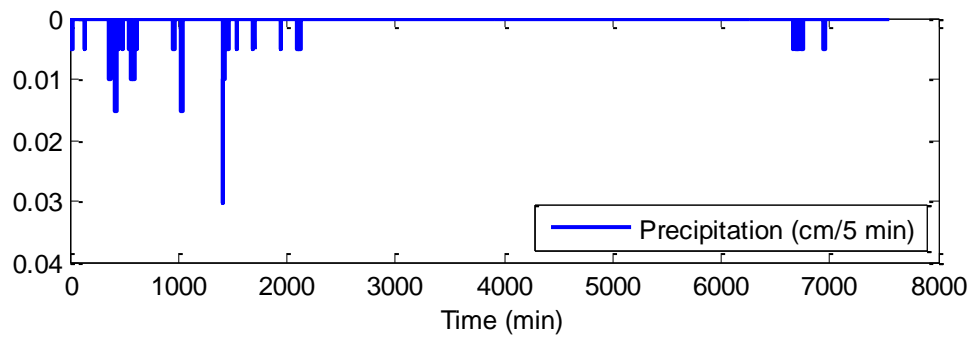

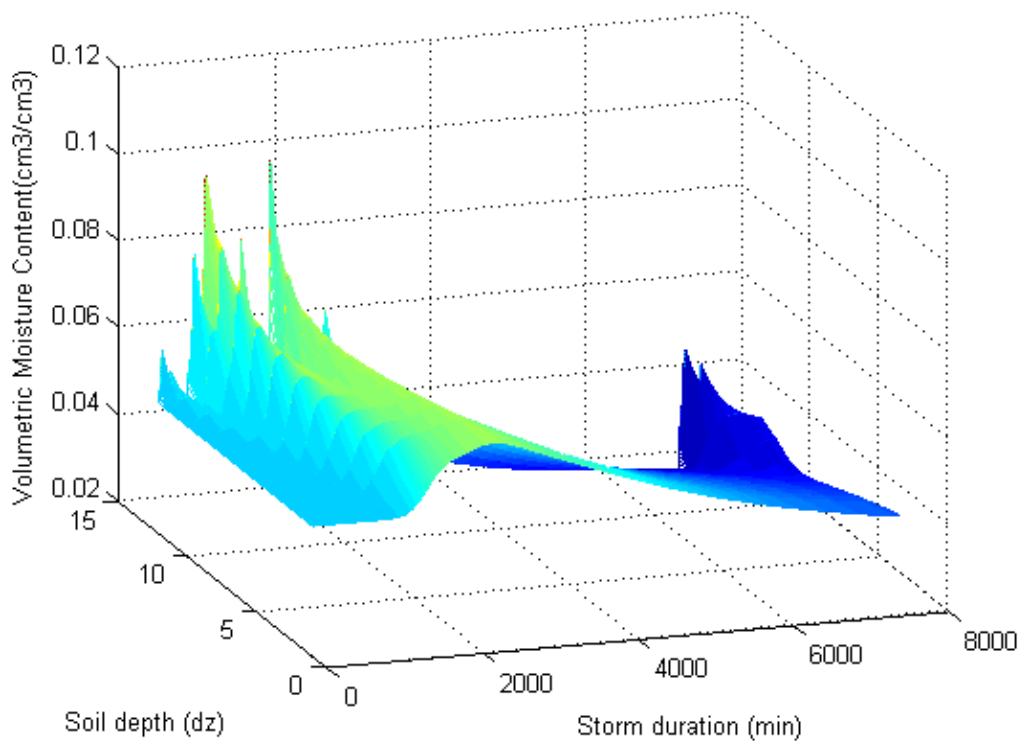
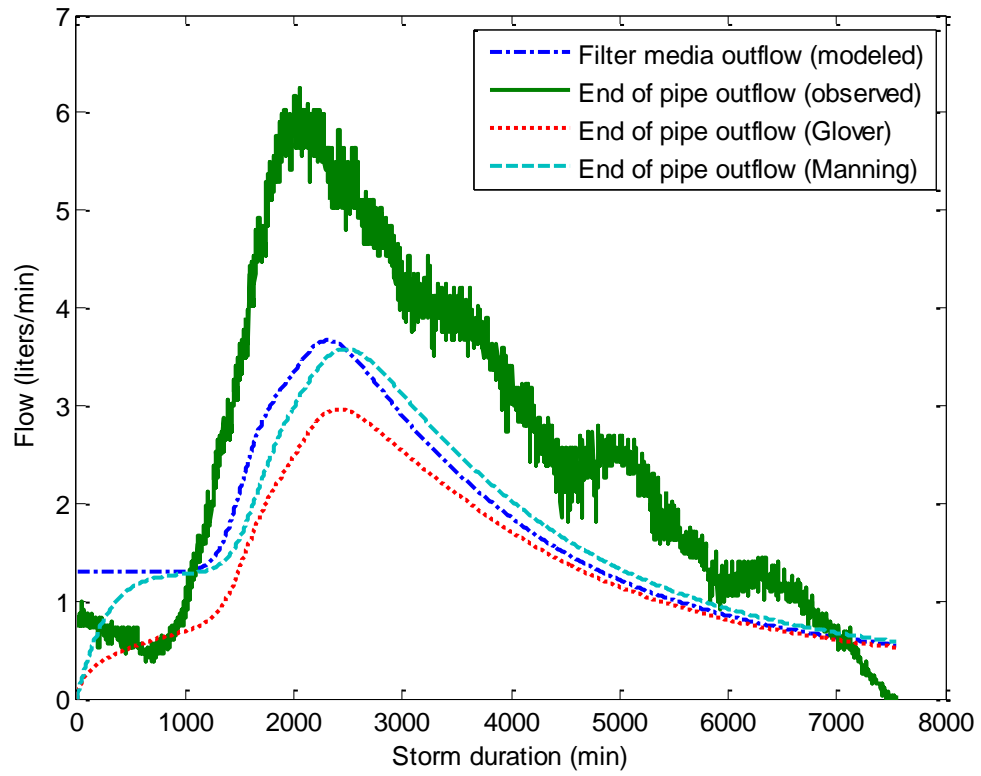

08/21/2009 Storm Event

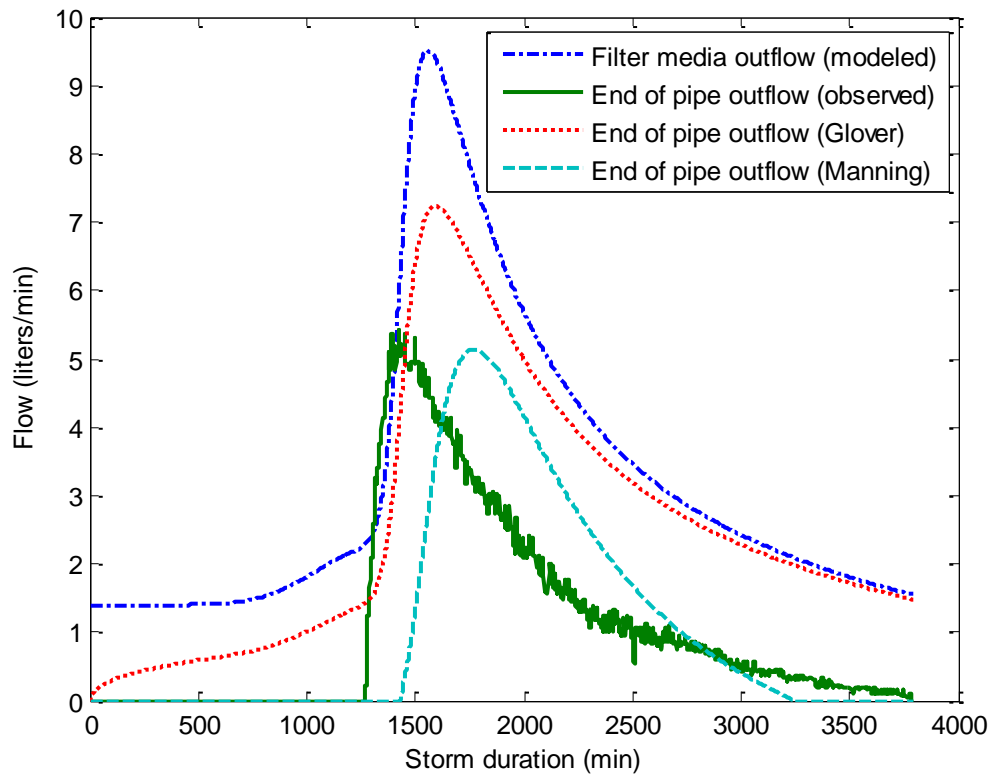
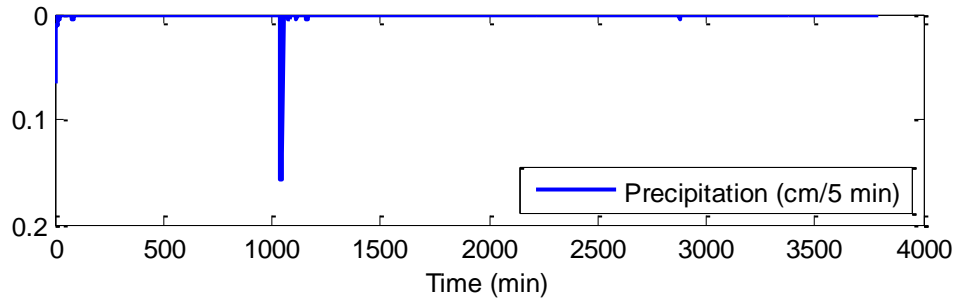

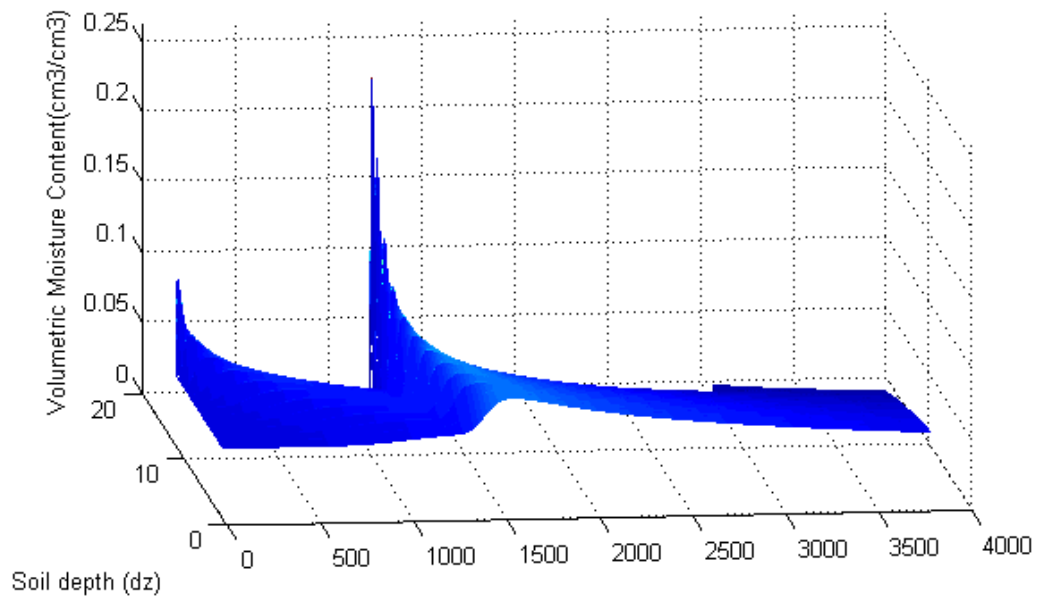

08/28/2009 Storm Event

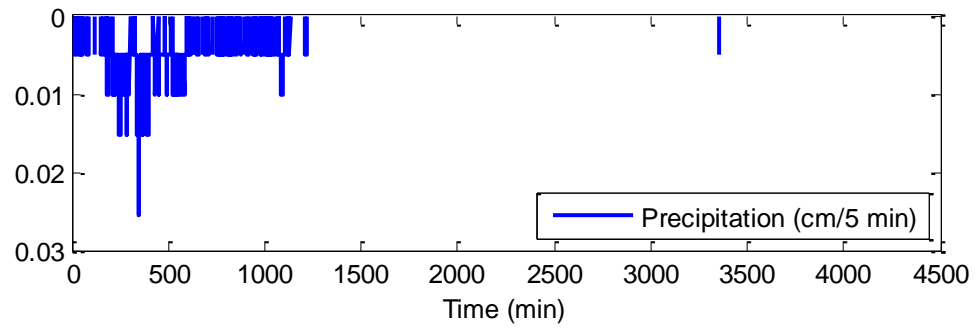

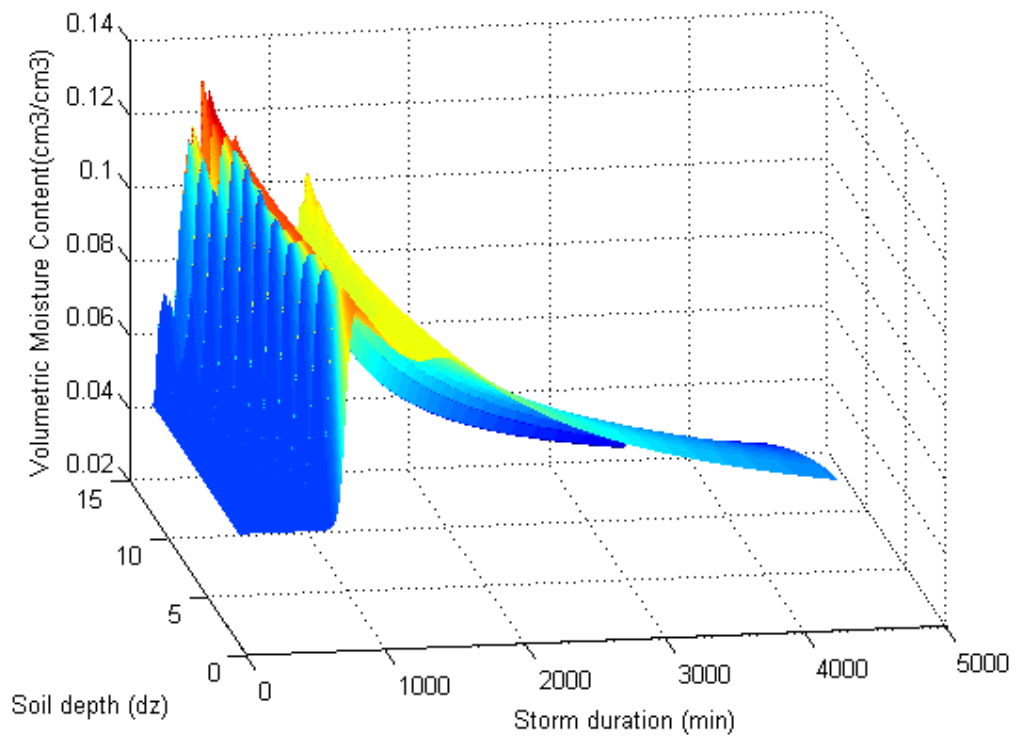
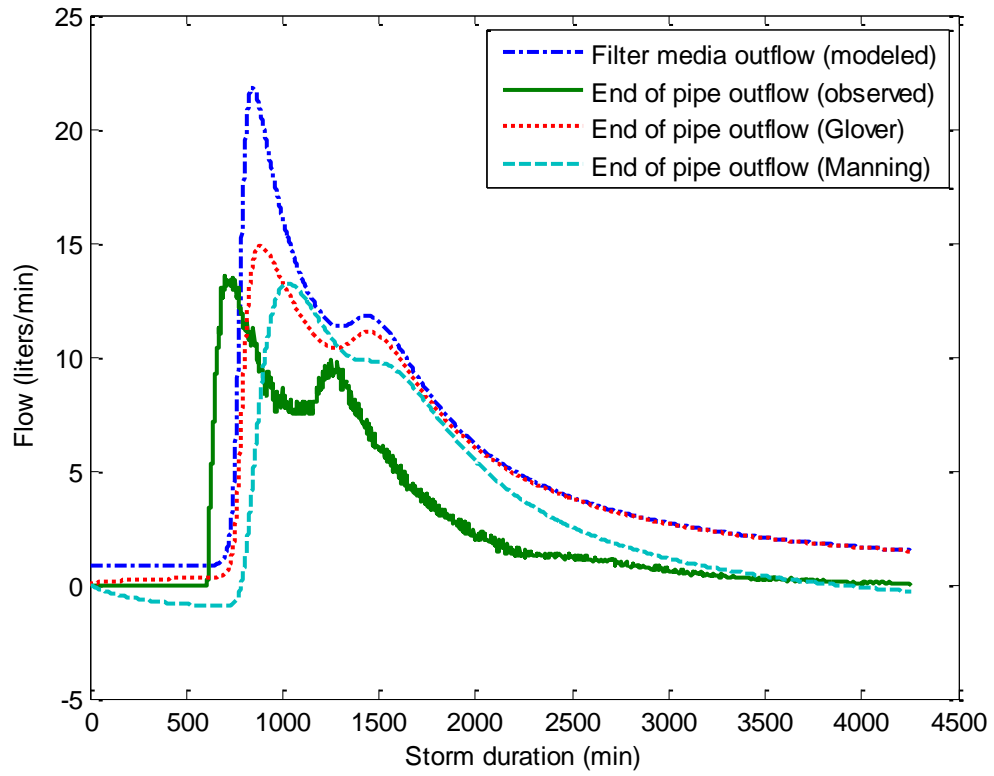

09/11/2009 Storm Event

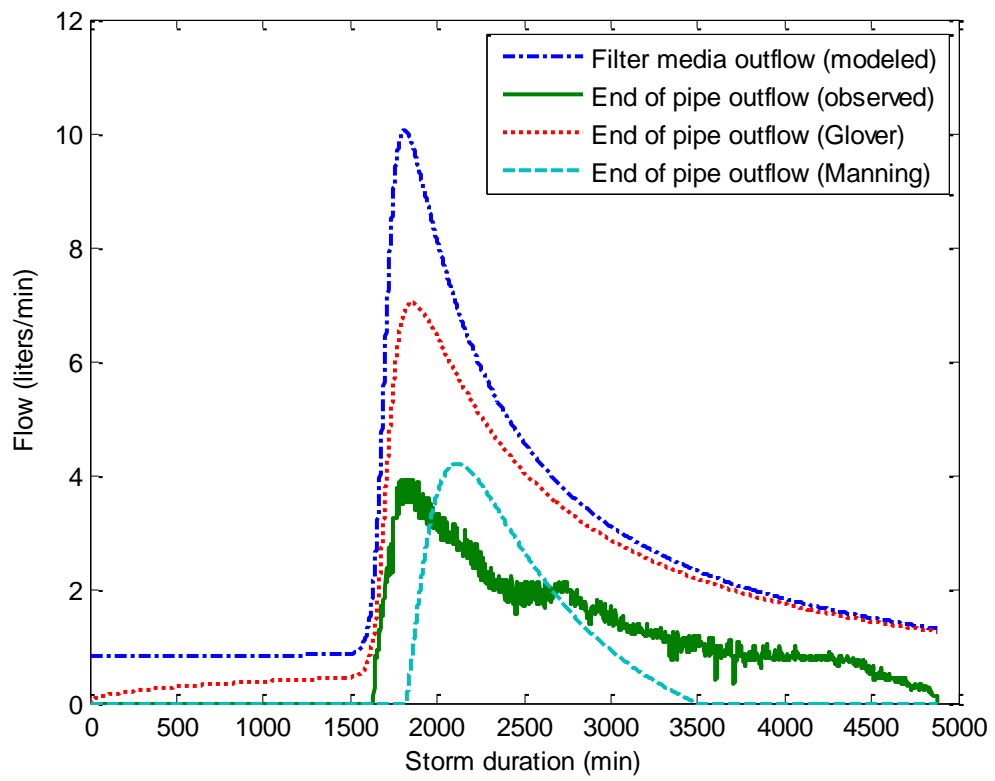
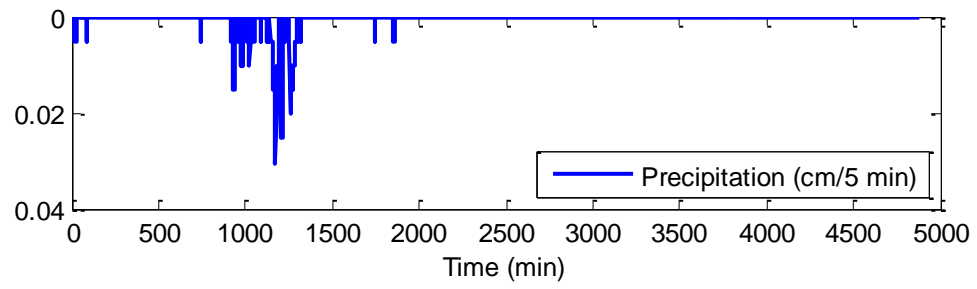

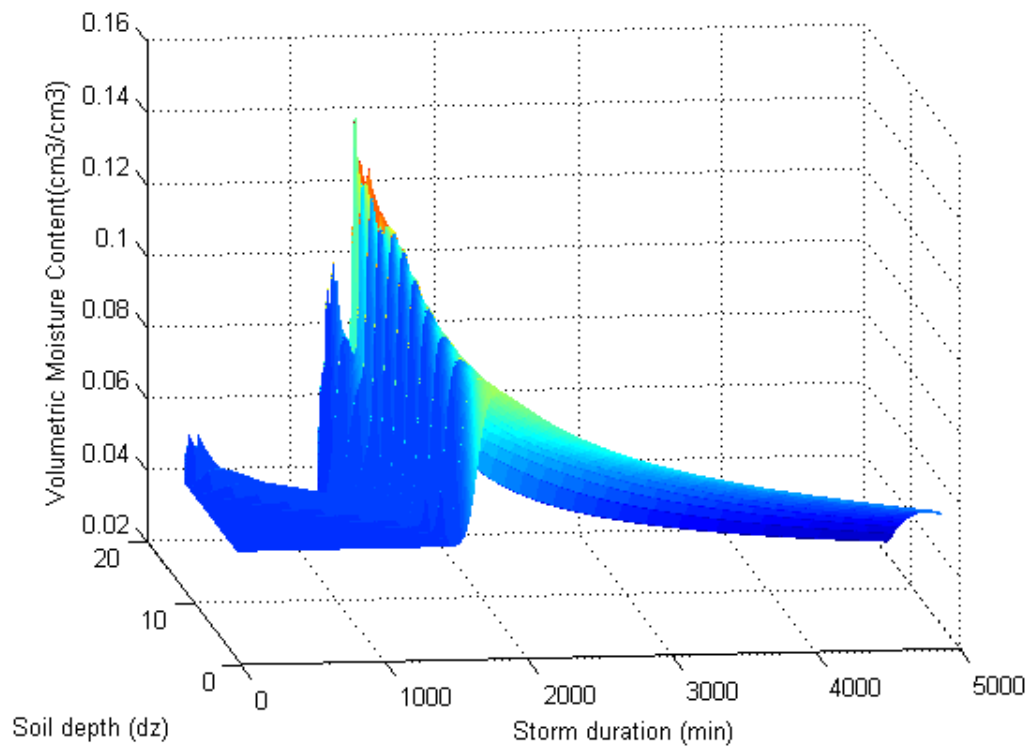

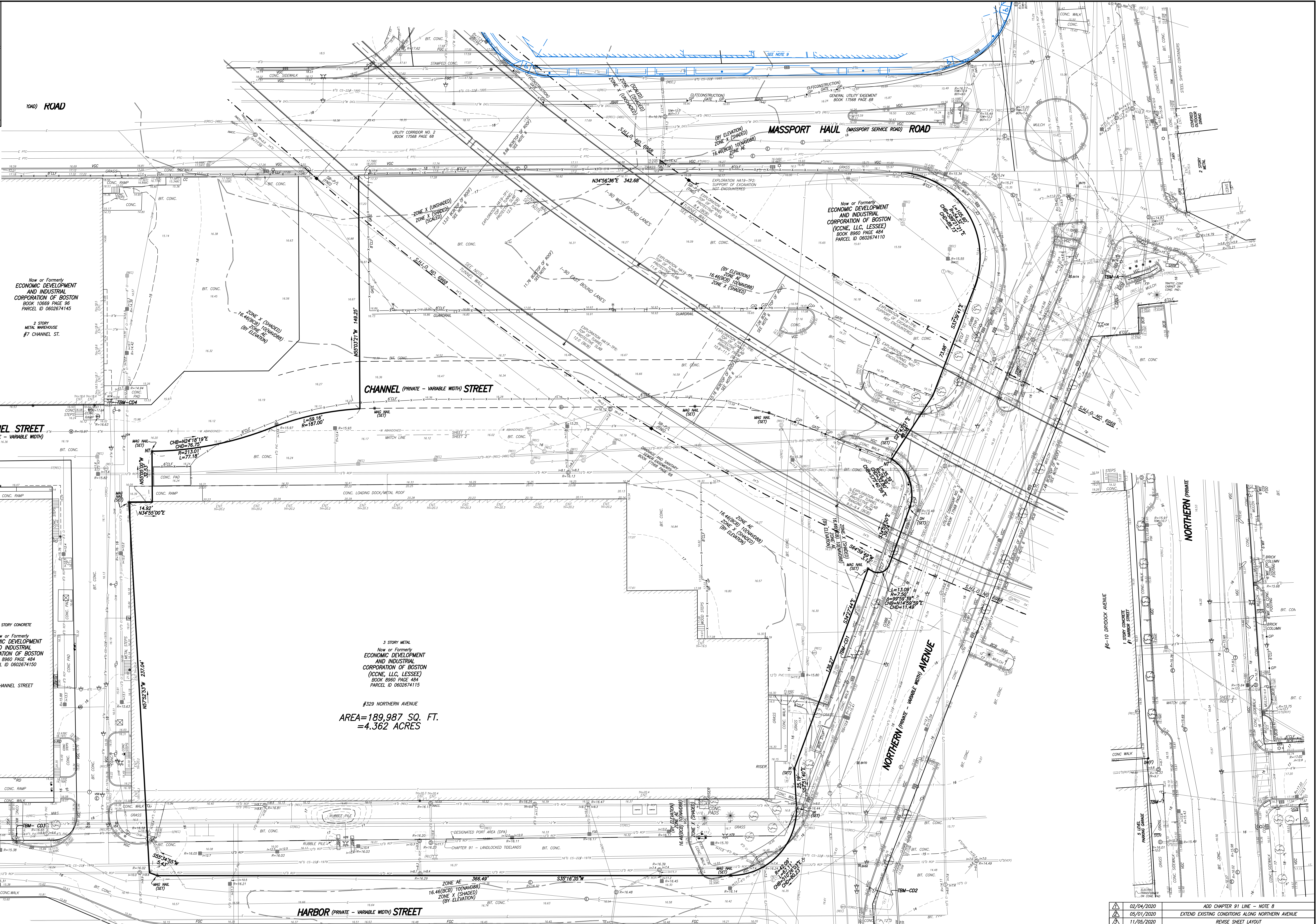
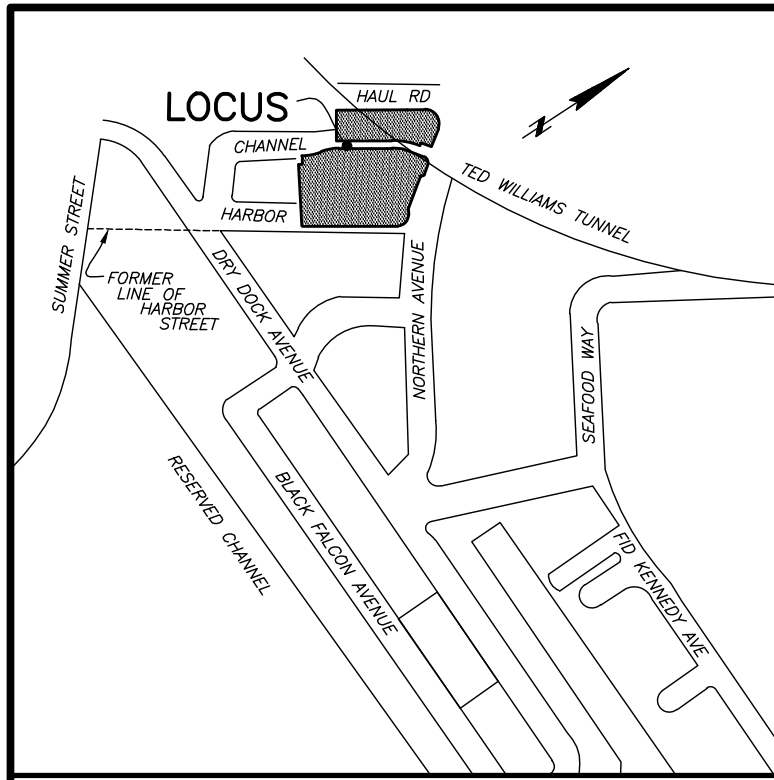

Now or Formerly
ECONOMIC DEVELOPMENT
AND INDUSTRIAL
CORPORATION OF BOSTON
BOOK 8960 PAGE 484
PARCEL ID 0602674145

2 STORY
METAL WAREHOUSE
#7 CHANNEL ST.

CHANNEL STREET
(PRIVATE - VARIABLE WIDTH)

9 STORY CONCRETE
Now or Formerly
ECONOMIC DEVELOPMENT
AND INDUSTRIAL
CORPORATION OF BOSTON
BOOK 8960 PAGE 484
PARCEL ID 0602674150

#12 CHANNEL STREET

3 STORY METAL
Now or Formerly
ECONOMIC DEVELOPMENT
AND INDUSTRIAL
CORPORATION OF BOSTON
(ICONE, LLC, LESSEE)
BOOK 8960 PAGE 484
PARCEL ID 0602674115

#329 NORTHERN AVENUE
AREA=189,987 SQ. FT.
=4.362 ACRES

VARIABLE WIDTH STREET

HARBOR (PRIVATE - VARIABLE WIDTH) STREET

MASSPORT HAUL (MASSPORT SERVICE ROAD) ROAD

NORTHERN AVENUE
(PRIVATE - VARIABLE WIDTH)

NOTES:

- BENCH MARK INFORMATION:
BENCH MARK USED:
ELEVATIONS ESTABLISHED FROM GPS OBSERVATION.
- TBM-A: SOUTHWEST CORNER OF GRANITE SON BASE (RAYMOND FLYNN SON), AS SHOWN HEREON.
ELEVATION = 17.44
- TBM-B: LEFT LOWER CORNER OF SOUTHWEST CONCRETE STAIRCASE AT BOSTON SEAFOOD CENTER.
ELEVATION = 18.12
- TBM-C: CHISELED SQUARE ON RETAINING WALL AT EAST FACE OF TUNNEL.
ELEVATION = 18.88
- TEMPORARY BENCH MARKS SET:
TBM-C01: TOP OF RIGHT BONNET BOLT OVER THE MAIN OUTLET OF A HYDRANT ON THE SOUTHWESTERN SIDE OF NORTHERN AVENUE.
ELEVATION = 18.57
- TBM-C02: SPIKE IN UTILITY POLE 1 FOOT ABOVE GRADE, ON THE NORTHEASTERN SIDE OF NORTHERN AVENUE ACROSS FROM ITS INTERSECTION WITH HARBOR STREET.
ELEVATION = 17.73
- THIS DOCUMENT IS AN INSTRUMENT OF SERVICE OF FELDMAN LAND SURVEYORS ISSUED TO OUR CLIENT FOR PURPOSES RELATED DIRECTLY AND SOLELY TO FELDMAN LAND SURVEYORS' SCOPE OF SERVICES UNDER CONTRACT TO OUR CLIENT FOR THIS PROJECT. ANY USE OR REUSE OF THIS DOCUMENT FOR ANY REASON BY ANY PARTY FOR PURPOSES UNRELATED DIRECTLY AND SOLELY TO SAID CONTRACT SHALL BE AT THE USER'S SOLE AND EXCLUSIVE RISK AND LIABILITY, INCLUDING LIABILITY FOR VIOLATION OF COPYRIGHT LAWS, UNLESS WRITTEN CONSENT IS PROVIDED BY FELDMAN LAND SURVEYORS.
- TUNNEL WALLS WERE DRAFTED FROM LASER SCAN DATA COLLECTED ON JULY 15 AND 16, 2019.
- TEST PIT EXPLORATION INFORMATION WAS TAKEN FROM A MEMORANDUM PROVIDED BY HALEY & ALDRICH, INC., DATED AUGUST 15, 2019.
- THE CHAPTER 91 LANDLOCKED ISLANDS LINE IS SHOWN FROM MASSGIS DATA ON LAYER "ISLANDS JURISDICTION CHAPTER 91 UNLOADED ISLANDS".
- AREA UNDER SUBSTANTIAL CONSTRUCTION BUILDING AND IMPROVEMENTS SHOWN IN BLUE WERE PROVIDED IN AN ELECTRONIC CAD FILE ENTITLED "3723-534.dwg".
- BY GRAPHIC PLOTTING AND AN ELEVATION SURVEY, THE PARCELS SHOWN HEREON LIE PARTIALLY WITHIN A ZONE "X" (UNSHADED), AN AREA OUTSIDE OF THE 0.2% ANNUAL CHANCE FLOOD, PARTIALLY WITHIN A ZONE "Y" (SHADED), AN AREA OF 0.2% ANNUAL CHANCE FLOOD HAZARD, AREAS OF 1% ANNUAL CHANCE FLOOD WITH AVERAGE DEPTH OF LESS THAN ONE FOOT ON WITH DRAINAGE AREAS OF LESS THAN 1 SQUARE MILE, AND PARTIALLY WITHIN A ZONE "AE" WITH BASE FLOOD ELEVATION DETERMINED, AS SHOWN ON THE FEDERAL EMERGENCY MANAGEMENT AGENCY (FEMA) FLOOD INSURANCE RATE MAP (FIRM) FOR SUFFOLK COUNTY, MASSACHUSETTS, MAP NUMBER 25025C0081, CITY OF BOSTON COMMUNITY NUMBER 25086, PANEL NUMBER C081, HAVING AN EFFECTIVE DATE OF MARCH 16, 2016.

02/04/2020	ADD CHAPTER 91 LINE - NOTE 8
05/01/2020	EXTEND EXISTING CONDITIONS ALONG NORTHERN AVENUE
11/05/2020	REVISE SHEET LAYOUT
05/04/2021	ADD FLOOD LINES - NOTE 10

EXISTING CONDITIONS SURVEY
#2 HARBOR STREET
BOSTON, MASS.

FELDMAN LAND SURVEYORS
152 HAMPDEN STREET
BOSTON, MASS. 02119

MARCH 20, 2019
PHONE: (617)357-9740
www.feldmansurveyors.com

FELDMAN
LAND SURVEYORS

I CERTIFY THAT THIS PLAN IS BASED ON AN ACTUAL FIELD SURVEY AND THE LATEST PLANS AND DEEDS OF RECORD.

TIMOTHY R. AGUIRRE, PLS. (MA# 52782)
TIM@FELDMANLANDSURVEYORS.COM

05/04/2021 DATE

20 0 10 20 40 80
SCALE: 1"=20'

RESEARCH	FIELD CHECK	PROJ. MGR. TRA	APPROVED	SHEET NO. 1 OF 1
CALC	CADD MAN. EAC	FIELD CHECKED	ORD. FILE 17321A	JOB NO. 17321A
FILENAME: S:\PROJECTS\179006\179006\DWG\17907-EG.dwg				

SEDIMENTATION AND EROSION CONTROL NOTES

- ALL EROSION AND SEDIMENT CONTROL MEASURES ARE TO BE CONSTRUCTED AND MAINTAINED IN ACCORDANCE WITH PUBLISHED EROSION CONTROL AND SEDIMENT GUIDELINES FOR MASSACHUSETTS (SEE REFERENCE BELOW, NOTE #7).
- ANY EROSION AND SEDIMENT CONTROL MEASURES FOR THE STABILIZATION OF SLOPES ARE TEMPORARY FOR CONSTRUCTION PHASES ONLY. SEE GRADING PLAN FOR FINAL STABILIZATION OF SLOPES.
- SEDIMENT CONTROL MEASURES SHALL BE ADJUSTED TO MEET FIELD CONDITIONS AT THE TIME OF AND DURING ALL PHASES OF CONSTRUCTION AND BE CONSTRUCTED PRIOR TO AND IMMEDIATELY AFTER ANY GRADING OR DISTURBANCE OF EXISTING SURFACE MATERIAL ON THE SITE.
- PERIODIC INSPECTION AND MAINTENANCE OF ALL SEDIMENT CONTROL STRUCTURES SHALL BE PROVIDED TO ENSURE THAT THE INTENDED PURPOSE IS ACCOMPLISHED. THE CONTRACTOR SHALL BE RESPONSIBLE FOR ALL SEDIMENT LEAVING THE LIMIT OF WORK. SEDIMENT CONTROL MEASURES SHALL BE IN WORKING CONDITION AT THE END OF EACH WORKING DAY.
- ALL POINTS OF CONSTRUCTION INGRESS OR EGRESS WILL BE PROTECTED WITH A STABILIZED CONSTRUCTION ENTRANCE TO PREVENT TRACKING OF MUD ONTO PUBLIC WAYS.
- ALL SEDIMENT WILL BE PREVENTED FROM ENTERING ANY STORM DRAINAGE SYSTEM (I.E. THROUGH THE USE OF STRAW BALES, CATCH BASIN SEDIMENT TRAPS, GRAVEL, BOARDS OR OTHER APPLICABLE METHODS).
- THE CONTRACTOR INSTALLING THE ABOVE SHALL OBTAIN AND FOLLOW THE "MASSACHUSETTS EROSION AND SEDIMENT CONTROL GUIDELINES FOR URBAN AND SUBURBAN AREAS" PREPARED BY DEPARTMENT OF ENVIRONMENTAL PROTECTION, BUREAU OF RESOURCE PROTECTION, DATED MAY 1997, REPRINTED MAY 2003 (OR LATEST EDITION), AND THE 2012 NPDES GENERAL PERMIT FOR STORMWATER DISCHARGES FROM CONSTRUCTION ACTIVITIES, OR LATEST EDITION.
- ALL DRAINAGE SWALES AND GROUND SURFACES WITHIN THE LIMIT OF WORK SHALL BE PROTECTED.
- AFTER ANY SIGNIFICANT RAINFALL (0.25" OR GREATER), SEDIMENT CONTROL STRUCTURES SHALL BE INSPECTED FOR INTEGRITY. ANY DAMAGED DEVICES SHALL BE CORRECTED IMMEDIATELY.
- ALL STOCKPILES SHALL BE PROTECTED AND LOCATED A MINIMUM OF 100' AWAY FROM EXISTING WATER BODIES OR WETLANDS & WITHIN THE LIMIT OF WORK. SOIL STOCKPILES SHALL BE PROTECTED FROM CONTACT WITH ON-SITE STORMWATER RUNOFF USING TEMPORARY PERIMETER SEDIMENT BARRIERS. A COVER (TARP) OR APPROPRIATE TEMPORARY STABILIZATION WILL BE PROVIDED TO MINIMIZE SEDIMENT DISCHARGE.
- STABILIZED PORTIONS OF A SITE SHALL BE INSPECTED AT LEAST ONCE PER MONTH.
- ANY SEDIMENT TRACKED ONTO PAVED AREAS SHALL BE SWEEPED AT THE END OF EACH WORKING DAY.
- ALL DEBRIS GENERATED DURING SITE PREPARATION ACTIVITIES SHALL BE LEGALLY DISPOSED OF OFF-SITE.
- ALL TOPSOIL ENCOUNTERED WITHIN THE WORK AREA SHALL BE STRIPPED TO ITS FULL DEPTH AND STOCKPILED FOR REUSE. TOPSOIL NOT NEEDED AFTER COMPLETION OF ALL FINAL TOPSOIL SPREADING AND GRASSING SHALL BE REMOVED FROM THE SITE AND LEGALLY RECYCLED OR DISPOSED OF. TOPSOIL PILES SHALL REMAIN SEGREGATED FROM EXCAVATED SUBSURFACE SOIL MATERIALS.
- TEMPORARY DIVERSION DITCHES, PERMANENT DITCHES, CHANNELS, EMBANKMENTS AND ANY DENUDED SURFACE WHICH WILL BE EXPOSED FOR A PERIOD OF 14 CALENDAR DAYS OR MORE SHALL BE CONSIDERED CRITICAL VEGETATION AREAS. THESE AREAS SHALL BE MULCHED WITH STRAW. MULCH SHALL BE SPREAD UNIFORMLY IN A CONTINUOUS BLANKET OF SUFFICIENT THICKNESS TO COMPLETELY HIDE THE SOIL FROM VIEW.
- AN EROSION CONTROL BARRIER SHALL BE INSTALLED ALONG THE EDGE OF PROPOSED DEVELOPMENT AS INDICATED IN THE PLAN PRIOR TO COMMENCEMENT OF DEMOLITION OR CONSTRUCTION OPERATIONS.
- THE CONTRACTOR IS RESPONSIBLE FOR REMOVAL OF ALL EROSION AND SEDIMENT CONTROLS AT THE COMPLETION OF SITE CONSTRUCTION.
- MEANS OF EROSION AND SEDIMENT PROTECTION AS NOTED ON THE DRAWINGS INDICATE THE MINIMUM PROVISIONS NECESSARY. ADDITIONAL MEANS OF PROTECTION SHALL BE PROVIDED BY THE CONTRACTOR AS REQUIRED FOR CONTINUED OR UNFORESEEN EROSION PROBLEMS, AT NO ADDITIONAL EXPENSE TO THE OWNER.
- THE CONTRACTOR SHALL USE TEMPORARY SEEDING, MULCHING OR OTHER APPROVED STABILIZATION MEASURES TO PROTECT EXPOSED AREAS DURING PROLONGED CONSTRUCTION OR OTHER LAND DISTURBANCE. STOCKPILES THAT WILL BE EXPOSED FOR LONGER THAN 14 CALENDAR DAYS SHALL BE SEEDDED WITH AN ANNUAL RYE.
- SEE LANDSCAPE DRAWINGS FOR TREE PROTECTION DETAILS.

GENERAL NOTES:

- TOPOGRAPHIC DATA, PROPERTY LINE INFORMATION, AND EXISTING SITE FEATURES WERE OBTAINED FROM A PLAN ENTITLED "EXISTING CONDITIONS SURVEY #2 HARBOR STREET", PREPARED BY FELDMAN LAND SURVEYORS, DATED MARCH 20, 2019, UPDATED NOVEMBER 24, 2020.
- FLOODPLAIN INFORMATION WAS OBTAINED FROM THE FLOOD INSURANCE RATE MAP (FIRM) NO. 25025C0081J. THE SITE IS IN ZONE AE.
- THE CONTRACTOR SHALL COMPLY WITH MASSACHUSETTS GENERAL LAWS CHAPTER 82, SECTION 40, AS AMENDED, WHICH STATES THAT NO ONE MAY EXCAVATE IN THE COMMONWEALTH OF MASSACHUSETTS EXCEPT IN AN EMERGENCY WITHOUT 72 HOURS NOTICE, EXCLUSIVE OF SATURDAYS, SUNDAYS, AND LEGAL HOLIDAYS, TO NATURAL GAS PIPELINE COMPANIES, AND MUNICIPAL UTILITY DEPARTMENTS THAT SUPPLY GAS, ELECTRICITY, TELEPHONE, OR CABLE TELEVISION SERVICE IN OR TO THE CITY OR TOWN WHERE THE EXCAVATION IS TO BE MADE. THE CONTRACTOR SHALL CALL "DIG SAFE" AT 1-888-DIG-SAFE.
- THE CONTRACTOR SHALL COMPLY WITH MASSACHUSETTS GENERAL LAWS CHAPTER 82A, ALSO REFERRED TO AS JACKIE'S LAW, AS DETAILED IN SECTION 520 CMR 14.00 OF THE CODE OF MASSACHUSETTS REGULATIONS.
- THE CONTRACTOR SHALL COMPLY WITH ALL APPLICABLE FEDERAL, STATE, AND LOCAL LAWS, RULES, REGULATIONS AND SAFETY CODES IN THE CONSTRUCTION OF ALL IMPROVEMENTS.
- THE LOCATIONS AND ELEVATIONS OF ALL EXISTING UTILITIES ARE APPROXIMATE AND ALL UTILITIES MAY NOT BE SHOWN. PRESENCE AND LOCATIONS OF ALL UTILITIES WITHIN THE LIMIT OF WORK MUST BE DETERMINED BY THE CONTRACTOR PRIOR TO COMMENCEMENT OF CONSTRUCTION ACTIVITY. THE CONTRACTOR SHALL BE RESPONSIBLE FOR IDENTIFYING AND CONTACTING THE CONTROLLING AUTHORITIES AND/OR UTILITY COMPANIES RELATIVE TO THE LOCATIONS AND ELEVATIONS OF THEIR LINES. THE CONTRACTOR SHALL KEEP A RECORD OF ANY DISCREPANCIES OR CHANGES IN THE LOCATIONS OF ANY UTILITIES SHOWN OR ENCOUNTERED DURING CONSTRUCTION. ANY DISCREPANCIES SHALL BE REPORTED TO THE OWNER AND NITSCH ENGINEERING. ANY DAMAGE RESULTING FROM THE FAILURE OF THE CONTRACTOR TO MAKE THESE DETERMINATIONS AND CONTACTS SHALL BE BORNE BY THE CONTRACTOR.
- THE CONTRACTOR SHALL, THROUGHOUT CONSTRUCTION, TAKE ADEQUATE PRECAUTIONS TO PROTECT ALL WALKS, GRADING, SIDEWALKS AND SITE DETAILS OUTSIDE OF THE LIMIT OF WORK AS DEFINED ON THE DRAWINGS AND SHALL REPAIR AND REPLACE OR OTHERWISE MAKE GOOD AS DIRECTED BY THE ENGINEER OR OWNER'S DESIGNATED REPRESENTATIVE ANY SUCH OR OTHER DAMAGE SO CAUSED.
- THE CONTRACTOR SHALL BE SOLELY RESPONSIBLE FOR JOB SITE SAFETY AND ALL CONSTRUCTION MEANS AND METHODS.
- PRIOR TO BEGINNING CONSTRUCTION, THE CONTRACTOR SHALL BECOME FAMILIAR WITH THE SITE AND CONSTRUCTION DOCUMENTS TO DEVELOP A THOROUGH UNDERSTANDING OF THE PROJECT, INCLUDING ANY SPECIAL CONDITIONS AND CONSTRAINTS.
- IT IS THE CONTRACTOR'S RESPONSIBILITY TO BECOME FAMILIAR WITH THE PROJECT SITE AND TO VERIFY ALL CONDITIONS IN THE FIELD AND REPORT DISCREPANCIES BETWEEN PLANS AND ACTUAL CONDITIONS TO THE OWNER OR OWNER'S REPRESENTATION IMMEDIATELY.
- THE CONTRACTOR SHALL CONDUCT ALL NECESSARY CONSTRUCTION NOTIFICATIONS AND APPLY FOR AND OBTAIN ALL NECESSARY CONSTRUCTION PERMITS.
- THE CONTRACTOR IS SOLELY RESPONSIBLE FOR THE ESTABLISHMENT AND USE OF ALL VERTICAL AND HORIZONTAL CONSTRUCTION CONTROLS.
- ELEVATIONS REFER TO BOSTON CITY BASE.
- THE CONTRACTOR SHALL COMPLY WITH THE ORDER OF CONDITIONS DATED XXXX XX, XXXX AND ISSUED BY THE XXXX CONSERVATION COMMISSION (DEP #XXX-XXX).
- FOR SOIL INFORMATION REFER TO GEOTECHNICAL REPORT.

BWSC & CONTRACTOR NOTES:

- THE ESTIMATED SANITARY SEWAGE DISCHARGE IS 60,926 GALLONS PER DAY (GPD). THIS ESTIMATE IS BASED ON 310 C.M.R. 15.000 THE STATE ENVIRONMENTAL CODE, TITLE 5; STANDARD REQUIREMENTS FOR THE SITING, CONSTRUCTION, INSPECTION, UPGRADE AND EXPANSION OF ON-SITE SEWAGE TREATMENT AND DISPOSAL SYSTEMS AND FOR THE TRANSPORT AND DISPOSAL OF SEPTAGE.
- THE ESTIMATED DAILY WATER USE IS 67,019 [110% SEWAGE NUMBER ABOVE] GPD BASED ON THE ESTIMATED SANITARY SEWAGE DISCHARGE WITH A 10% PEAKING FACTOR. THE PEAK DOMESTIC FLOW BASED ON FIXTURE COUNTS IS APPROXIMATELY XX GPM.
- ONE 4" AND ONE 3" COMPOUND WATER METER WILL BE EITHER NEPTUNE OR ELSTER AMCO COMPOUND TYPE METERS. THE METERS MUST BE PURCHASED BY THE CONTRACTOR. A METER TRANSMITTER UNIT (MTU) SHALL BE SUPPLIED BY THE COMMISSION AT THE OWNER'S EXPENSE. A FEE OF \$325/MTU WILL BE PAID TO THE COMMISSION AT THE TIME OF FILING THE GENERAL SERVICE APPLICATION.
- BACKWATER VALVES SHALL BE PROVIDED BY THE PLUMBER AT ALL GRAVITY SANITARY SEWER AND STORM DRAIN CONNECTIONS FOR ANY FIXTURE LOCATED AT AN ELEVATION BELOW THE TOP OF THE SEWER OR DRAIN MANHOLE.
- THE CONTRACTOR SHALL NOTIFY THE BWSC CROSS-CONNECTION DEPARTMENT AT 617-989-7283 ONCE BACKWATER VALVES ARE INSTALLED FOR BWSC INSPECTION.
- DYE TESTING SHALL BE PERFORMED ON NEW STORM DRAIN AND SANITARY SEWER CONNECTIONS AFTER INSTALLATION IS COMPLETE. DYE TESTS SHALL BE WITNESSED BY THE BWSC.
- A PREREQUISITE FOR FILING A GENERAL SERVICE APPLICATION WITH THE BWSC FOR NEW CONSTRUCTION IS THE ROUGH CONSTRUCTION SIGN-OFF DOCUMENT FROM THE CITY OF BOSTON'S INSPECTORIAL SERVICES DEPARTMENT.
- AN AS-BUILT PLAN (AUTOCAD 2016 OR EARLIER RELEASE) SHALL BE PROVIDED BY THE CONTRACTOR AND ENDORSED BY A CIVIL ENGINEER OR PROFESSIONAL LAND SURVEYOR SHOWING THE LOCATION, DEPTH, AND INVERT OF EVERY BEND, FITTING, VALVE, CLEANOUT AND ANCHOR. THE AS-BUILT DRAWING SHALL BE SUBMITTED TO THE BOSTON AND WATER SEWER COMMISSION FOR REVIEW AND APPROVAL.
- WATER SHUT DOWN SHALL BE COORDINATED WITH BWSC WATER OPERATIONS, (617) 989-7276, 24 HOURS NOTICE REQUIRED.
- PROVIDE "DON'T DUMP" PLAQUES AT ALL CATCH BASIN AND DRAIN INLET LOCATIONS. "DON'T DUMP" PLAQUES TO BE PURCHASED FROM BWSC.
- THE CONTRACTOR SHALL PURCHASE THE NEW HYDRANT(S) FROM THE BWSC. THE CONTRACTOR SHALL PURCHASE THE HYDRANT(S) FROM THE COMMISSION WHEN FILING THE GENERAL SERVICE APPLICATION.
- EXISTING WATER METER(S) TO BE REMOVED OR REPLACED SHALL BE RETURNED TO BWSC.
- THE CONTRACTOR SHALL VIDEO INSPECT THE EXISTING BWSC MAINS WITHIN THE PROJECT SITE, NORTHERN AVENUE, AND HARBOR STREET PRIOR TO CONSTRUCTION AND AFTER CONSTRUCTION IS COMPLETE AND SUBMIT TO BWSC AND NITSCH ENGINEERING FOR REVIEW. THE INSPECTION SOFTWARE SHALL BE CAPABLE OF EXPORTING DIGITAL INSPECTION LOG DATA INTO AN MSACCESS DATABASE IN THE PIPELINE ASSESSMENT AND CERTIFICATION PROGRAM (PACP) STANDARD EXCHANGE FORMAT. THE INSPECTION SOFTWARE CODING SYSTEM SHALL BE PACP CERTIFIED (LATEST EDITION) AS PER THE NATIONAL ASSOCIATION OF SEWER SERVICE COMPANIES (NASSCO). THE SOFTWARE SHALL BE EQUIPPED WITH ALL MODULES NECESSARY FOR PACP INSPECTIONS AND SCORING. THE CONTRACTOR SHALL COORDINATE DIRECTLY WITH BWSC TO DETERMINE AN APPROVED VIDEO INSPECTION COMPANY AND DELIVERABLE.

BWSC INSPECTION SIGN-OFF	INSPECTOR	DATE	COMMENT	DYE TEST
(A) CB216				
(B) SMH100				N/A
(C) SMH101				N/A
(D) SMH104				
(E) SMH102				N/A
(F) CONNECT TO EX. SMH				
(G) CONNECT TO EX. DMH				
(H) CB218				
(I) CB209				
(K) 16"x6" TAPPING SLEEVE & VALVE				
(L) SADDLE CONNECTION				
(M) CB207				
(N) CB210				
(O) DMH137				
(P) DMH121				
(R) DMH118				
(S) SADDLE CONNECTION				
(T) CONNECT TO EX. DMH				
(U) CB219				
(V) DMH127				
(W) DMH115				
(X) DMH139				
(Y) CB221				
(Z) OCS601				
(A) CB205				
(B) DMH120				
(C) DMH119				
(D) DMH136				
(E) CB208				
(F) CB213				
(G) WQ5501				
(H) CB217				

BWSC INSPECTION SIGN-OFF	INSPECTOR	DATE	COMMENT	DYE TEST
(A) CB214				
(B) DMH116				
(C) DMH135				
(D) DMH130				
(E) AD308				
(F) DMH132				
(G) AD306				
(H) AD304				
(I) DMH134				
(J) DMH144				
(K) DMH133				
(L) DMH138				
(M) TD#2				
(N) TD#3				
(O) WQ5500				
(P) AD300				
(Q) TD#4				
(R) DMH142				
(S) TD#1				
(T) DMH117				
(U) DMH131				
(V) DMH126				
(W) DMH140				
(X) AD301				
(Y) AD305				
(Z) OCS600				
(A) AD302				
(B) DMH147				
(C) AD303				
(D) AD307				
(E) CB204				
(F) SMH103				

DEMOLITION NOTES:

- SITE PREPARATION AND DEMOLITION SHALL INCLUDE THOSE AREAS WITHIN THE LIMIT OF WORK LINE AS SHOWN ON THE CONTRACT DOCUMENTS.
- ANY AREA OUTSIDE THE LIMIT OF WORK THAT IS DISTURBED SHALL BE RESTORED TO ITS ORIGINAL CONDITION AT NO ADDITIONAL COST TO THE OWNER.
- CONSULT ALL OF THE DRAWINGS AND SPECIFICATIONS FOR COORDINATION REQUIREMENTS BEFORE COMMENCING DEMOLITION.
- THE CONTRACTOR SHALL COORDINATE SITE DEMOLITION EFFORTS WITH ALL TRADES THAT MAY BE AFFECTED BY THE WORK.
- ALL ITEMS REQUIRING REMOVAL SHALL BE REMOVED TO FULL DEPTH TO INCLUDE BASE MATERIAL AND FOOTINGS OR FOUNDATIONS AS REQUIRED TO FACILITATE CONSTRUCTION, AND LEGALLY DISPOSED OF OFFSITE BY CONTRACTOR.
- UTILITY PIPES DESIGNATED TO BE ABANDONED IN PLACE SHALL BE PLUGGED AT THEIR ENDS WITH WATERIGHT BRICK MASONRY OR CEMENT MORTAR WITH A MINIMUM THICKNESS OF 8 INCHES.
- UTILITY PIPES DESIGNATED TO BE REMOVED SHALL CONSIST OF THE COMPLETE REMOVAL AND DISPOSAL OF THE ENTIRE LENGTH OF PIPE AND BACKFILL AND 95% COMPACTION OF THE VOID WITH ORDINARY BORROW. WHEN THE VOID IS WITHIN THE FOOTPRINT OF THE NEW BUILDING, GRAVEL BORROW SHALL BE USED TO BACKFILL THE VOID.
- UTILITY STRUCTURES DESIGNATED TO BE ABANDONED IN PLACE SHALL HAVE THEIR CAST IRON CASTINGS REMOVED AND DISPOSED, INLET AND OUTLET PIPES PLUGGED, THE BOTTOM OF THE STRUCTURES SHALL BE BROKEN, THE VOID OF THE STRUCTURES SHALL BE BACKFILLED AND COMPACTED TO 95% WITH ORDINARY BORROW OR FLOWABLE FILL, AND THE TOP OF THE STRUCTURE SHALL BE REMOVED SO THAT IT IS AT LEAST 36 INCHES BELOW FINISH GRADE.
- UTILITY STRUCTURES DESIGNATED TO BE REMOVED SHALL CONSIST OF THE REMOVAL AND DISPOSAL OF CAST IRON CASTINGS, PLUGGING OF INLET AND OUTLET PIPES, REMOVAL OF THE STRUCTURE, AND BACKFILL AND 95% COMPACTION OF THE VOID WITH ORDINARY BORROW. WHEN HE VOID IS WITHIN THE FOOTPRINT OF THE NEW BUILDING, GRAVEL BORROW SHALL BE USED TO BACKFILL THE VOID.
- ALL DEBRIS GENERATED DURING SITE PREPARATION ACTIVITIES SHALL BE LEGALLY DISPOSED OF OFFSITE.
- AT ALL LOCATIONS WHERE EXISTING CURBING, CONCRETE PAVEMENT OR BITUMINOUS CONCRETE ROADWAY ABUTS NEW CONSTRUCTION, THE EDGE OF THE EXISTING CURB OR PAVEMENT SHALL BE SAW CUT TO A CLEAN, SMOOTH EDGE.
- EXTEND DESIGNATED LIMIT OF WORK AS NECESSARY TO ACCOMPLISH ROUGH GRADING, EROSION CONTROL, TREE PROTECTION, AND SITE WORK AS REQUIRED BY THESE DRAWINGS AND SPECIFICATIONS.
- THE CONTRACTOR SHALL REMOVE FROM THE SITE ALL RUBBISH AND DEBRIS FOUND THEREON. STORAGE OF SUCH MATERIALS ON THE PROJECT SITE WILL NOT BE PERMITTED. THE CONTRACTOR SHALL LEAVE THE SITE IN SAFE, CLEAN, AND LEVEL CONDITION UPON COMPLETION OF THE SITE DEMOLITION WORK.
- REMOVE AND STOCKPILE ALL EXISTING SITE LIGHTS, BENCHES, TRASH RECEPTACLES, TRAFFIC SIGNS, GRANITE CURB, AND OTHER SITE IMPROVEMENTS WITHIN LIMIT OF WORK LINE UNLESS OTHERWISE NOTED.
- ALL EXISTING TREES AND SHRUBS TO REMAIN SHALL BE PROTECTED AND MAINTAINED THROUGHOUT THE TIME OF CONSTRUCTION, AS SPECIFIED AND DIRECTED BY THE LANDSCAPE ARCHITECT.
- BEFORE ANY TREES OR SHRUBS ARE REMOVED, THE CONTRACTOR SHALL ARRANGE A CONFERENCE ON THE SITE WITH THE OWNER OR OWNER'S REPRESENTATIVE TO IDENTIFY TREES AND SHRUBS THAT ARE TO BE REMOVED, AS WELL AS THOSE WHICH ARE TO BE PROTECTED. DO NOT COMMENCE CLEARING OPERATIONS WITHOUT A CLEAR UNDERSTANDING OF EXISTING CONDITIONS TO BE PRESERVED.
- THE CONTRACTOR SHALL REMOVE FROM THE AREA OF CONSTRUCTION PAVEMENT, CONCRETE, CURBING, POLES AND FOUNDATIONS, ISLANDS, TREE BERMS AND OTHER FEATURES WITHIN THE LIMITS OF CONSTRUCTION AS REQUIRED TO ACCOMMODATE NEW CONSTRUCTION WHETHER SPECIFIED ON THE DRAWINGS OR NOT.

UTILITY NOTES:

- ALL UTILITY CONNECTIONS ARE SUBJECT TO THE APPROVAL OF, AND GRANTING OF PERMITS BY, THE LOCAL MUNICIPALITY. IT SHALL BE THE SOLE RESPONSIBILITY OF THE CONTRACTOR TO OBTAIN ALL PERMITS AND APPROVALS RELATED TO UTILITY WORK PRIOR TO COMMENCEMENT OF CONSTRUCTION.
- THE CONTRACTOR SHALL BE SOLELY RESPONSIBLE FOR OBTAINING ALL PERMISSIONS FOR, AND FOR CONDUCTING ALL PREPARATIONS RELATED TO, WORK AFFECTING ANY UTILITIES WITHIN THE JURISDICTION OF ANY NON-MUNICIPAL UTILITY COMPANY, INCLUDING BUT NOT LIMITED TO ELECTRIC, TELEPHONE, AND/OR GAS. THE CONTRACTOR SHALL NOTIFY ALL APPROPRIATE AGENCIES, DEPARTMENTS, AND UTILITY COMPANIES, IN WRITING, AT LEAST 7 DAYS (OR PER UTILITY COMPANY REQUIREMENT) AND NOT MORE THAN 30 DAYS PRIOR TO ANY CONSTRUCTION.
- THE CONTRACTOR SHALL MAINTAIN UTILITIES SERVICING BUILDINGS AND FACILITIES WITHIN OR OUTSIDE THE PROJECT LIMIT UNLESS THE INTERRUPTION OF SERVICE IS COORDINATED WITH THE OWNER.
- ALL WATER, SEWER, AND DRAIN WORK SHALL BE PERFORMED ACCORDING TO THE REQUIREMENTS AND STANDARD SPECIFICATIONS OF THE LOCAL MUNICIPALITY.
- GAS, TELECOMMUNICATIONS AND ELECTRIC SERVICES ARE TO BE DESIGNED BY EACH UTILITY COMPANY IN COORDINATION WITH THE MECHANICAL, ELECTRIC, AND PLUMBING CONSULTANTS.
- THE CONTRACTOR SHALL COORDINATE CONSTRUCTION ACTIVITIES OF NEW UTILITIES WITH GAS, TELECOMMUNICATION AND ELECTRICAL SERVICES.
- INSTALL WATER LINES WITH A MINIMUM OF FIVE FEET OF COVER AND A MAXIMUM OF SEVEN FEET COVER FROM THE FINAL DESIGN GRADES.
- MAINTAIN 10 FEET HORIZONTAL SEPARATION AND 18 INCHES VERTICAL SEPARATION (WATER OVER SEWER) BETWEEN SEWER AND WATER LINES. WHEREVER THERE IS LESS THAN 10 FEET OF HORIZONTAL SEPARATION AND 18 INCHES OF VERTICAL SEPARATION BETWEEN A PROPOSED OR EXISTING SEWER LINE TO REMAIN AND A PROPOSED OR EXISTING WATER LINE TO REMAIN, BOTH WATER MAIN AND SEWER MAIN SHALL BE CONSTRUCTED OF MECHANICAL JOINT CEMENT LINED DUCTILE IRON PIPE FOR A DISTANCE OF 10-FEET ON EITHER SIDE OF THE CROSSING. ONE (1) FULL LENGTH OF WATER PIPE SHALL BE CENTERED OVER THE SEWER AT THE CROSSING.
- THE CONTRACTOR SHALL MAINTAIN ALL EXISTING UTILITIES EXCEPT THOSE NOTED TO BE ABANDONED AND/OR REMOVED & DISPOSED.
- THE GENERAL CONTRACTOR IS RESPONSIBLE FOR TRENCHING, BACKFILLING, AND SURFACE RESTORATION FOR GAS UTILITY SYSTEMS.
- ALL ON-SITE UTILITIES SHALL BE INSTALLED UNDERGROUND UNLESS OTHERWISE NOTED.
- ALL EXISTING AND PROPOSED MANHOLE FRAMES, COVERS, VALVES, CLEANOUTS, CASTINGS, ETC. SHALL BE RAISED TO FINISHED GRADE PRIOR TO FINAL GRADING AND PAVING CONSTRUCTION.
- ALL GRATES IN WALKWAYS SHALL BE ADA COMPLIANT.

PROPOSED LEGEND

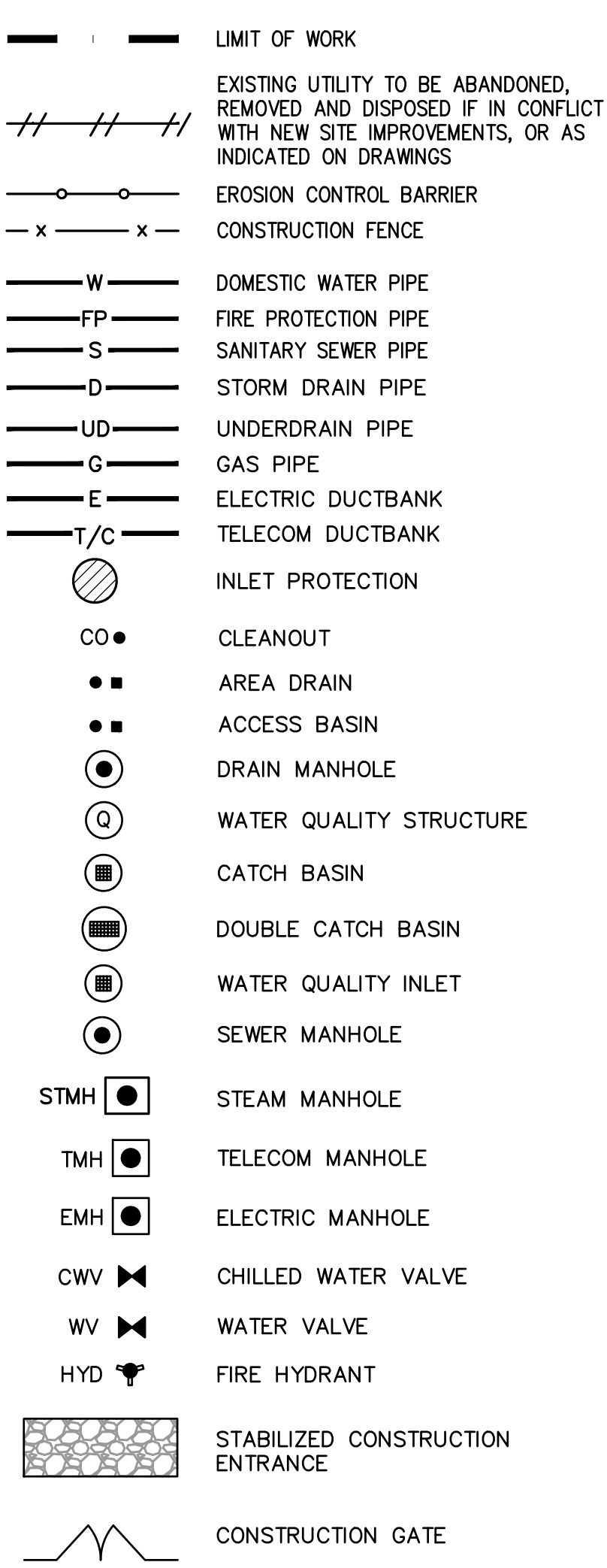

ABBREVIATIONS

AB	ACCESS BASIN
AD	AREA DRAIN
BC	BOTTOM OF CURB ELEVATION
BW	BOTTOM OF WALL ELEVATION
CB	CATCH BASIN
CI	CAST IRON
CO	CLEANOUT
CPP	CORRUGATED POLYETHYLENE PIPE
DI	DUCTILE IRON PIPE CEMENT LINER
DMH	DRAIN MANHOLE
EHH	ELECTRIC HANDHOLE
EMH	ELECTRIC MANHOLE
FD	FOUNDATION DRAIN
FFE	FINISHED FLOOR ELEVATION
HP	HIGH POINT
HYD	FIRE HYDRANT
INV	INVERT ELEVATION
LF	LINEAR FEET
LOW	LIMIT OF WORK
LP	LOW POINT
LW	LAB WASTE
M&P	MAINTAIN AND PROTECT
NIC	NOT IN CONTRACT
OCS	OUTLET CONTROL STRUCTURE
PD	PERIMETER DRAIN
PERF	PERFORATED
PVC	POLYVINYL CHLORIDE PIPE
R&D	REMOVE AND DISPOSE
R&S	REMOVE AND STOCKPILE
RD	ROOF DRAIN
RIM	RIM ELEVATION
SMH	SEWER MANHOLE
SS	SEWER SERVICE
TC	TOP OF CURB ELEVATION
TD	TRENCH DRAIN
TW	TOP OF WALL ELEVATION
THH	TELECOM HANDHOLE
TMH	TELECOM MANHOLE
TOP	TOP OF PIPE
TYP	TYPICAL
UD	UNDERDRAIN
USD	UNDERSLAB DRAIN
VGC	VERTICAL GRANITE CURB
WQI	WATER QUALITY INLET
WQS	WATER QUALITY STRUCTURE
WV	WATER VALVE

2 HARBOR
329 NORTHERN AVE
BOSTON, MA 02210

OWNER
BCP-CG HARBOR PROPERTY LLC
C/O BEACON CAPITAL PARTNERS, LLC
200 STATE STREET, FIFTH FLOOR
BOSTON, MA 02109

ARCHITECT
HANDEL ARCHITECTS, LLP
69 CANAL ST, 2ND FLOOR
BOSTON, MA 02114
T: 617.651.4790

CONSULTING ARCHITECT
STUDIO ENEE
460 HILLSIDE AVE
NEEDHAM, MA 02494
T: 781.858.3011

CONSULTING ARCHITECT
TRIA
21 DRYDOCK AVE, SUITE 330W
BOSTON, MA 02210
T: 617.530.1620

CIVIL ENGINEER
NITSCH ENGINEERING, INC.
2 CENTER PLAZA #430
BOSTON, MA 02108
T: 617.338.0063

MEP ENGINEER & CODE CONSULTANT
COSENTINI ASSOCIATES
101 FEDERAL ST #600
BOSTON, MA 02110
T: 617.748.7800

STRUCTURAL ENGINEER
DESIMONE CONSULTING ENGINEERS
31 MILK ST., SUITE 1016
BOSTON, MA 02109
T: 617.836.4492

LANDSCAPE ARCHITECT
KLOPPER MARTIN DESIGN GROUP
69 CANAL ST, 2ND FLOOR
BOSTON, MA 02114
T: 617.227.2560

ENVELOPE CONSULTANT
CBI CONSULTING, LLC
250 DORCHESTER AVE
BOSTON, MA 02127
T: 617.268.8977

GEOTECHNICAL
HALEY & ALDRICH, INC.
465 MEDFORD ST, SUITE 2200
BOSTON, MA 02129
T: 617.886.7400

NOT FOR CONSTRUCTION

NO.	DATE	ISSUANCE
1	12/20/2019	CONCEPT PRICING
2	12/15/2020	50% SCHEMATIC DESIGN
3	2/18/2021	100% SCHEMATIC DESIGN
4	4/16/2021	EARLY SITE PACKAGE

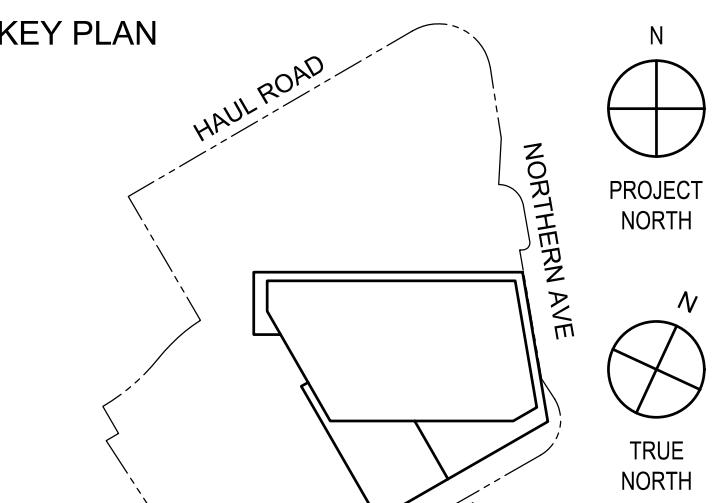

PROJECT DATUM: PROJ. 0'-0" = +16'-6" BCB
SCALE: AS NOTED
PROJECT NO: 1550
SEAL & SIGNATURE

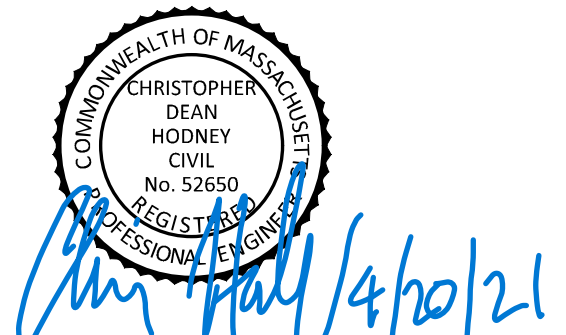

DRAWING TITLE:
**CIVIL NOTES,
LEGEND AND
ABBREVIATIONS**

DRAWING NO:
C-000

REQUIRED RETENTION VOLUME
Total Property Area = 189,987 sf
Existing Impervious Area = 186,830 sf
Proposed Impervious Area = 157,279 sf
1.25% of runoff over the total area = 157,279 sf * 1.25 in * 1ft/12in = 16,383 cubic feet of storage (BWSC requirement)
PROVIDED INFILTRATION VOLUME
Interior Stormwater Tank: 14,500 cf Vt = 14,500 cf
Infiltration System #1: MC-3500 Chambers (Refer to Stormwater Report I for infiltration calculations) Vt = 4,000 cf
Total Infiltration Volume: 14,500+4,000 = 18,500 cf
18,500 cf provided storage > 16,383 cf required storage

BWSC SITE PLAN #21
BWSC USE ONLY

SITE ADDRESS:
2 HARBOR STREET
BOSTON, MA 02210

NEW BWSC ACCOUNT/METER NUMBER:
XXXXXXXXXX/XXXXXXXXXX

WARD / PARCEL NUMBER:
06/02674115

SITE USE:
COMMERCIAL (C)

OWNER CONTACT INFORMATION:
ERIC EWER
BEACON CAPITAL PARTNERS
200 STATE ST
BOSTON, MA 02109

2 HARBOR

329 NORTHERN AVE
BOSTON, MA 02210

OWNER
BCP-CG HARBOR PROPERTY LLC
C/O BEACON CAPITAL PARTNERS, LLC
200 STATE STREET, FIFTH FLOOR
BOSTON, MA 02109

ARCHITECT
HANDEL ARCHITECTS, LLP
69 CANAL ST., 2ND FLOOR
BOSTON, MA 02114
T: 617.651.4790

CONSULTING ARCHITECT
STUDIO ENEE
460 HILLSIDE AVE
NEEDHAM, MA 02494
T: 781.858.3011

CONSULTING ARCHITECT
TRIA
21 DRYDOCK AVE, SUITE 330W
BOSTON, MA 02110
T: 617.530.1620

CIVIL ENGINEER
NITSCH ENGINEERING, INC.
2 CENTER PLAZA #430
BOSTON, MA 02108
T: 617.338.0063

MEP ENGINEER & CODE CONSULTANT
COSENTINI ASSOCIATES
101 FEDERAL ST #600
BOSTON, MA 02110
T: 617.748.7800

STRUCTURAL ENGINEER
DESIMONE CONSULTING ENGINEERS
31 MILK ST., SUITE 1016
BOSTON, MA 02109
T: 617.936.4492

LANDSCAPE ARCHITECT
KLOPFER MARTIN DESIGN GROUP
69 CANAL ST., 2ND FLOOR
BOSTON, MA 02114
T: 617.227.2560

ENVELOPE CONSULTANT
CBI CONSULTING, LLC
250 DORCHESTER AVE
BOSTON, MA 02127
T: 617.268.8977

GEOTECHNICAL
HALEY & ALDRICH, INC.
465 MEDFORD ST., SUITE 2200
BOSTON, MA 02129
T: 617.886.7400

NOT FOR CONSTRUCTION

NO.	DATE	ISSUANCE
1	12/20/2019	CONCEPT PRICING
2	12/15/2020	50% SCHEMATIC DESIGN
3	2/18/2021	100% SCHEMATIC DESIGN
4	4/16/2021	EARLY SITE PACKAGE

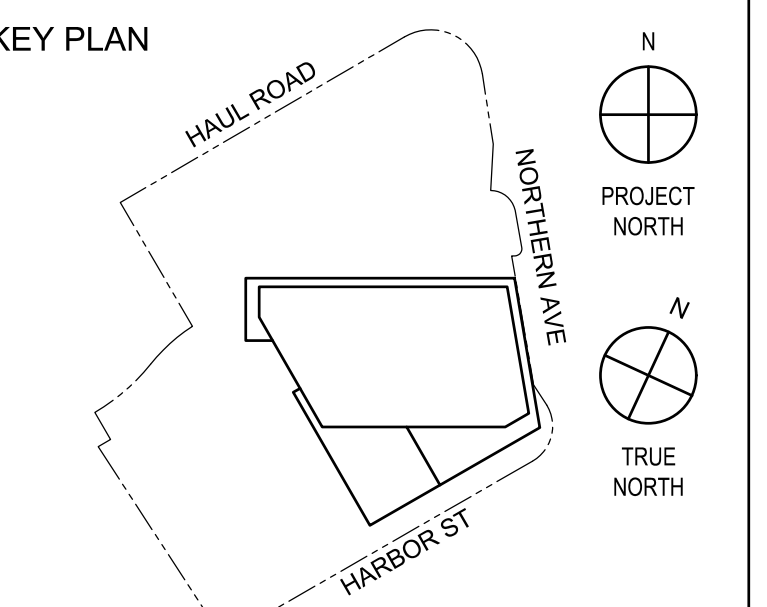

PROJECT DATUM: PROJ. 0'-0" = +16'-6" BCB
SCALE: 1" = 20'
PROJECT NO: 1550
SEAL & SIGNATURE

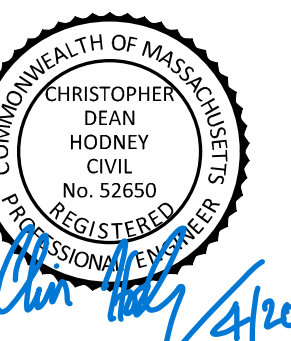

DRAWING TITLE:
**SITE SEDIMENTATION
& EROSION CONTROL
PLAN**

DRAWING NO:
C-200

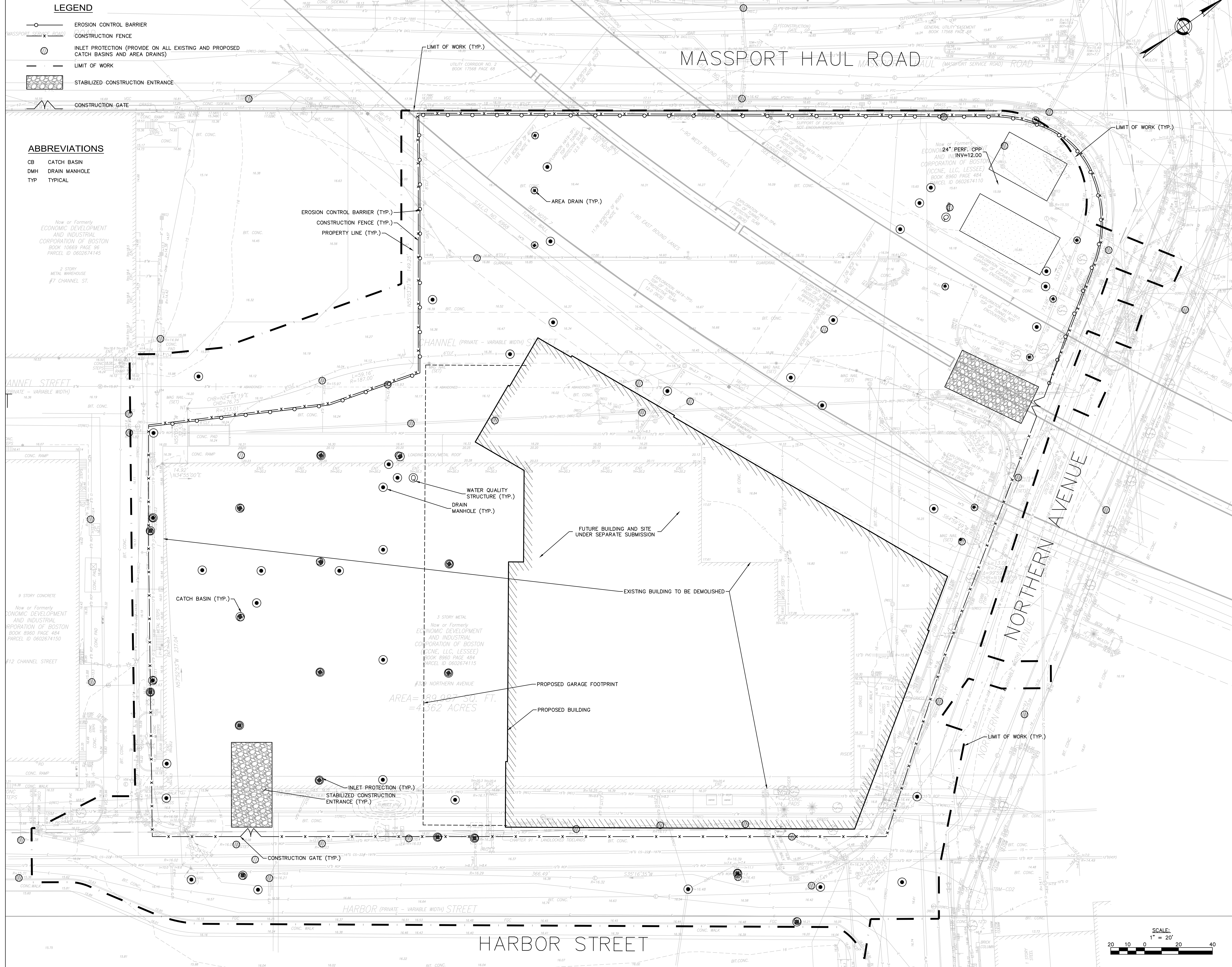

2 HARBOR

329 NORTHERN AVE
BOSTON, MA 02210

OWNER
BCP-CG HARBOR PROPERTY LLC
C/O BEACON CAPITAL PARTNERS, LLC
200 STATE STREET, FIFTH FLOOR
BOSTON, MA 02109

ARCHITECT
HANDEL ARCHITECTS, LLP
89 CANAL ST., 2ND FLOOR
BOSTON, MA 02114
T: 617.651.4790

CONSULTING ARCHITECT
STUDIO ENÉE
460 HILLSIDE AVE
NEEDHAM, MA 02494
T: 781.858.3011

CONSULTING ARCHITECT
TRIA
21 DRYDOCK AVE, SUITE 330W
BOSTON, MA 02210
T: 617.530.1620

CIVIL ENGINEER
NITSCH ENGINEERING, INC.
2 CENTER PLAZA #430
BOSTON, MA 02108
T: 617.338.0063

MEP ENGINEER & CODE CONSULTANT
COSENTINI ASSOCIATES
101 FEDERAL ST #600
BOSTON, MA 02110
T: 617.748.7800

STRUCTURAL ENGINEER
DESIMONE CONSULTING ENGINEERS
31 MILK ST., SUITE 1016
BOSTON, MA 02109
T: 617.936.4492

LANDSCAPE ARCHITECT
KLOPFER MARTIN DESIGN GROUP
89 CANAL ST., 2ND FLOOR
BOSTON, MA 02114
T: 617.227.2560

ENVELOPE CONSULTANT
CBI CONSULTING, LLC
250 DORCHESTER AVE
BOSTON, MA 02127
T: 617.268.8977

GEOTECHNICAL
HALEY & ALDRICH, INC.
465 MEDFORD ST., SUITE 2200
BOSTON, MA 02129
T: 617.886.7400

NOT FOR CONSTRUCTION

NO.	DATE	ISSUANCE
1	12/20/2019	CONCEPT PRICING
2	12/15/2020	50% SCHEMATIC DESIGN
3	2/18/2021	100% SCHEMATIC DESIGN
4	4/16/2021	EARLY SITE PACKAGE

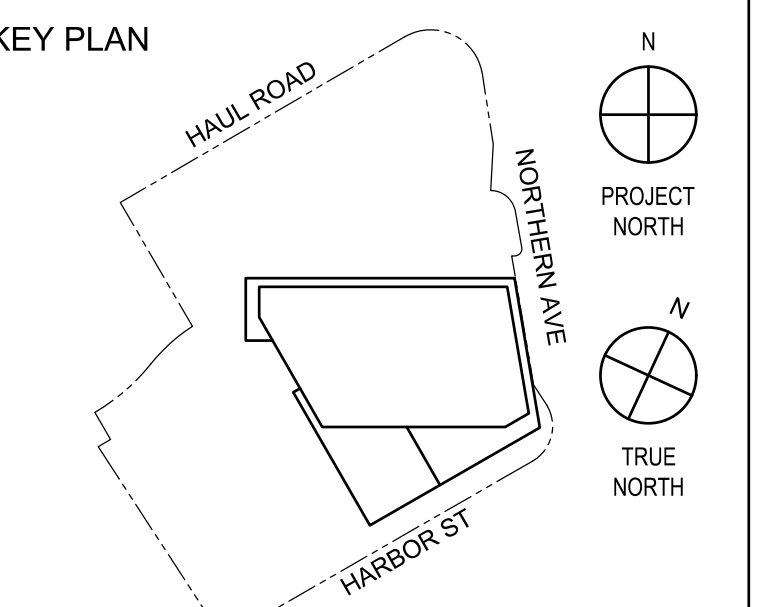

PROJECT DATUM: PROJ. 0'-0" = +16'-8" BCB
SCALE: AS NOTED
PROJECT NO: 1550
SEAL & SIGNATURE

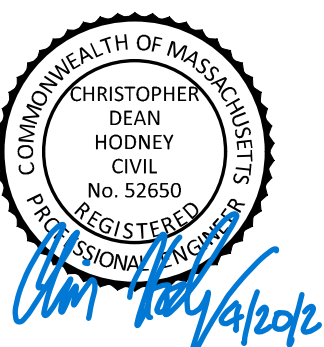

DRAWING TITLE: SEDIMENTATION & EROSION CONTROL DETAILS

DRAWING NO:

C-201

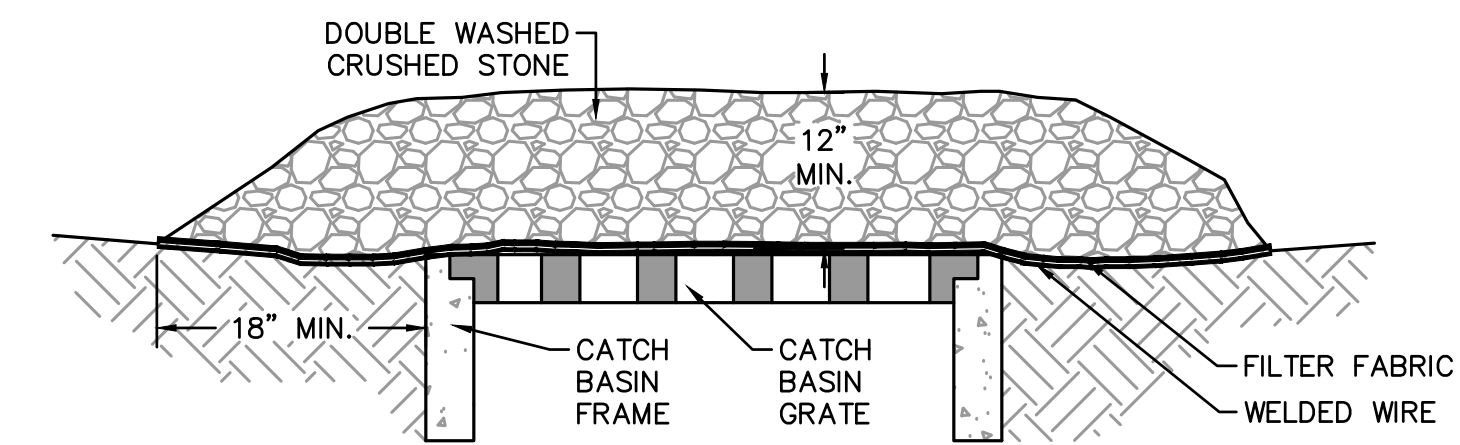

THIS METHOD OF INLET PROTECTION IS APPLICABLE WHERE HEAVY FLOWS ARE EXPECTED, BUT NOT WHERE PONDING AROUND THE STRUCTURE MIGHT CAUSE EXCESSIVE INCONVENIENCE OR DAMAGE TO ADJACENT STRUCTURES AND UNPROTECTED AREAS. THIS METHOD NOT ACCEPTABLE IN ACTIVE TRAFFIC AREAS.

INLET PROTECTION ① CATCH BASIN W/ GRAVEL NOT TO SCALE

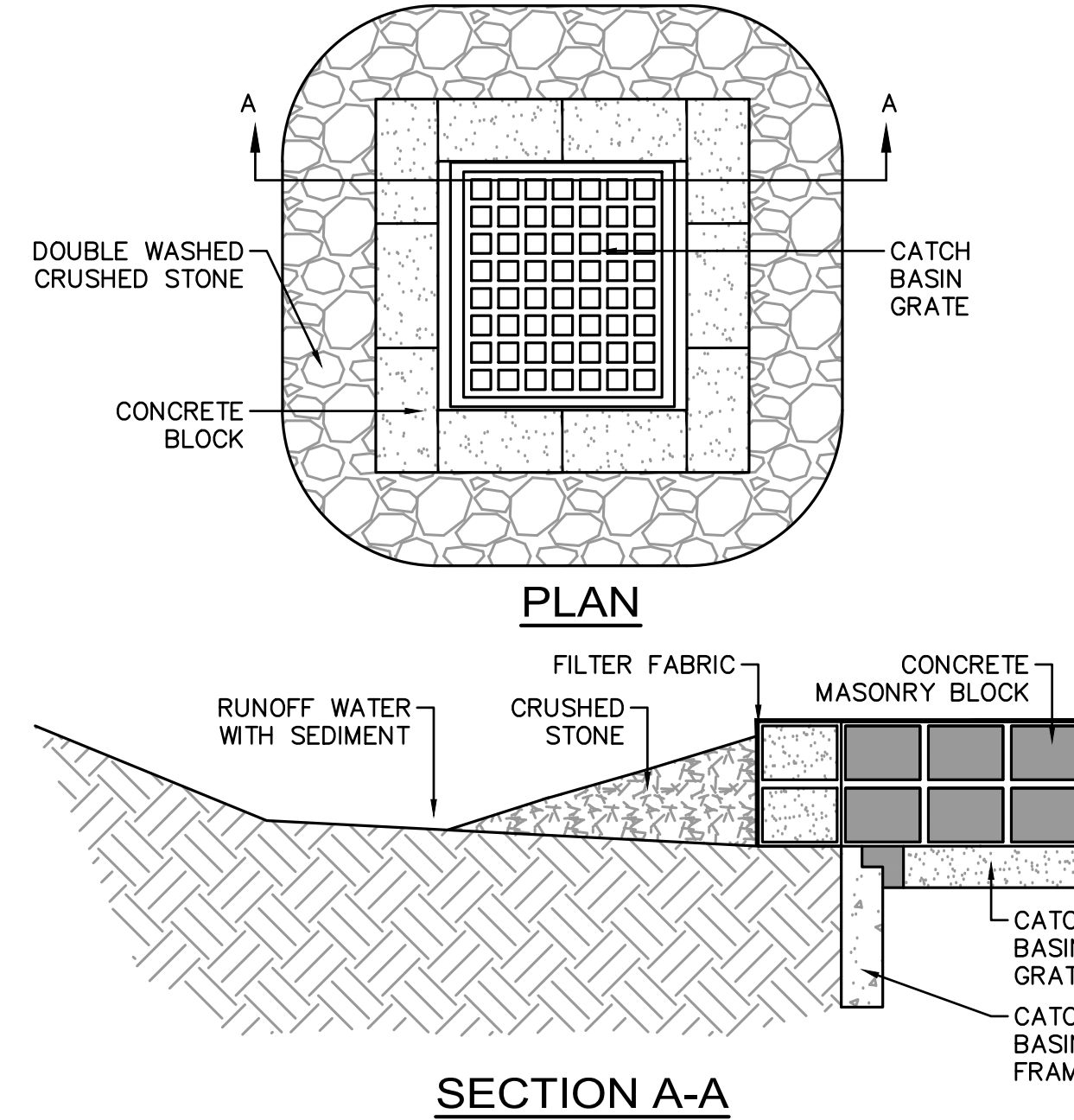

THIS METHOD OF INLET PROTECTION IS APPLICABLE WHERE HEAVY FLOWS ARE EXPECTED AND WHERE AN OVERFLOW CAPACITY IS NECESSARY TO PREVENT EXCESSIVE PONDING AROUND STRUCTURE.

INLET PROTECTION ③ CATCH BASIN W/ BLOCK AND GRAVEL

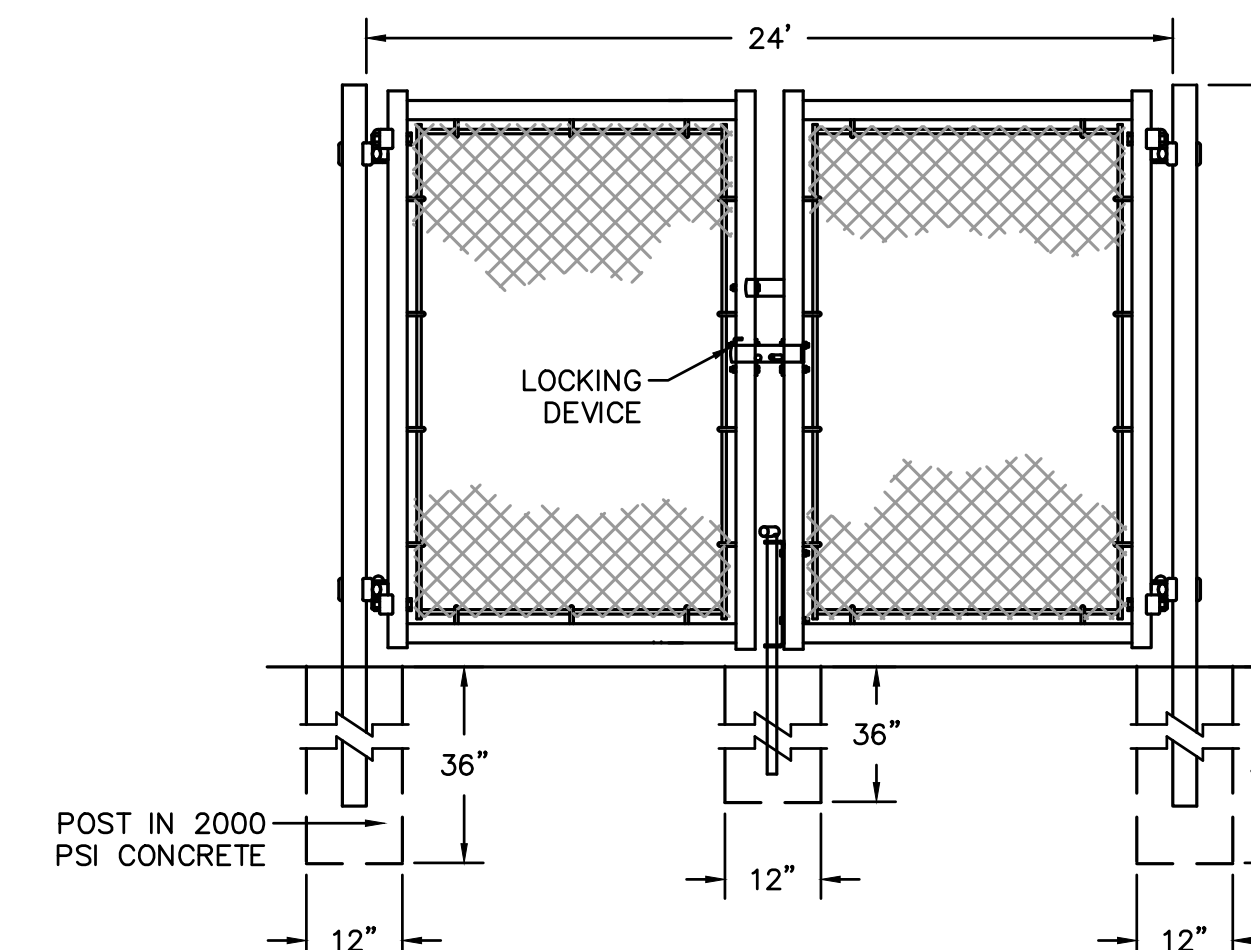
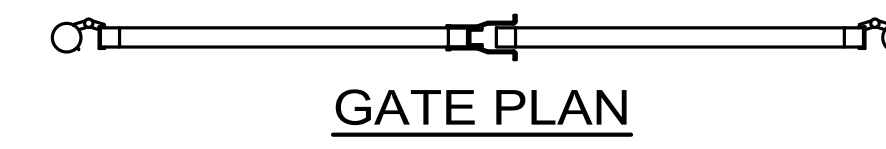

DOUBLE GATE ELEVATION NOT TO SCALE

24' WIDE CONSTRUCTION GATE (DOUBLE GATE) NOT TO SCALE

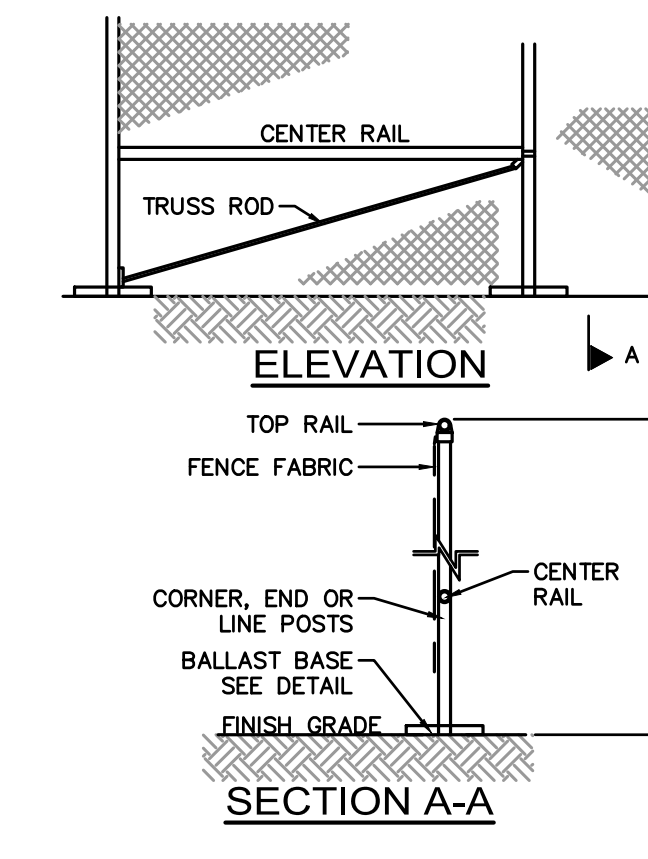

- NOTES
1. END, GATE AND CORNER POSTS SHALL BE BRACED TO ADJACENT LINE POSTS. (MORE THAN 30' CHANGE IN DIRECTION CONSTITUTES A CORNER)
 2. FABRIC SHALL BE 0.148" GAUGE MIN. WIRE, WOVEN INTO APPROXIMATELY 2" DIAMOND MESH.
 3. ZINC-COATED STEEL FABRIC BASE METAL SHALL BE COATED WITH PRIME WESTERN SPELTER OR EQUAL.
 4. ALUMINUM COATED STEEL FABRIC BASE METAL SHALL BE COATED WITH ALUMINUM ALLOY.
 5. LINE POSTS SHALL BE 2 1/2" O.D. END OR CORNER POSTS SHALL BE 3" O.D.
 6. THE CONTRACTOR IS RESPONSIBLE FOR SURFACE RESTORATION ONCE THE FENCE IS REMOVED.
 7. THE CONTRACTOR SHALL REMOVE AND DISPOSE OF THE TEMPORARY CONSTRUCTION FENCE AT THE CONCLUSION OF THE PROJECT.

TEMPORARY CONSTRUCTION CHAIN LINK FENCE WITH BALLAST BASE NOT TO SCALE

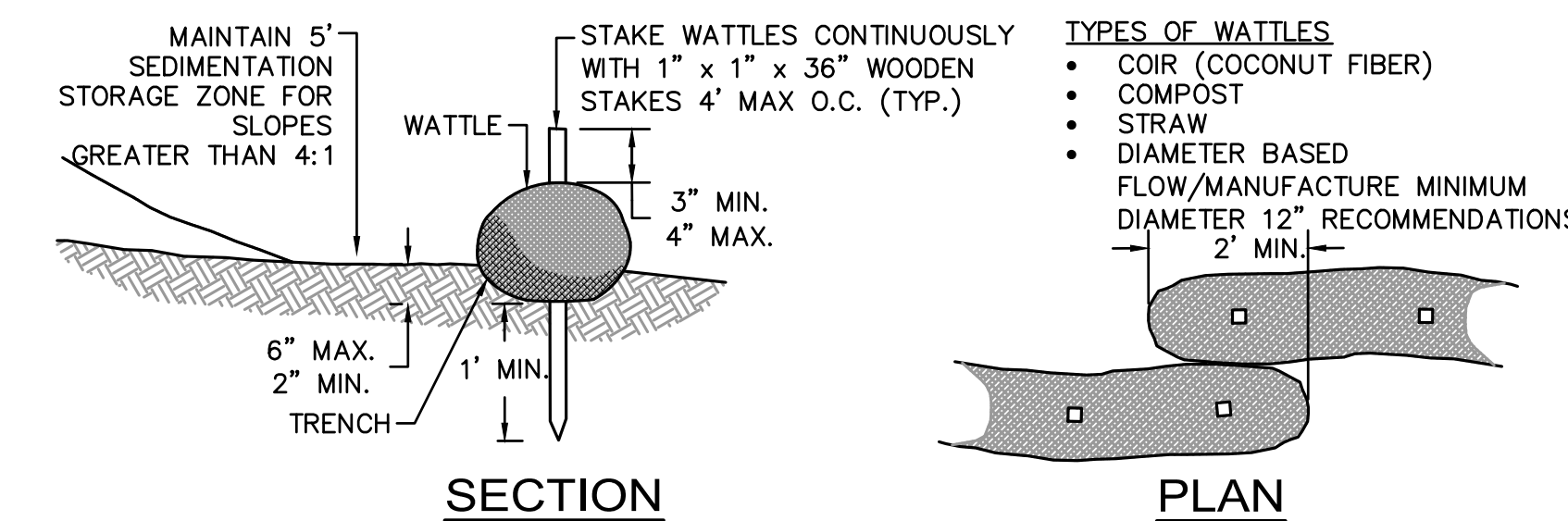

WATTLES - SLOPE PROTECTION FOR SLOPES NOT TO SCALE

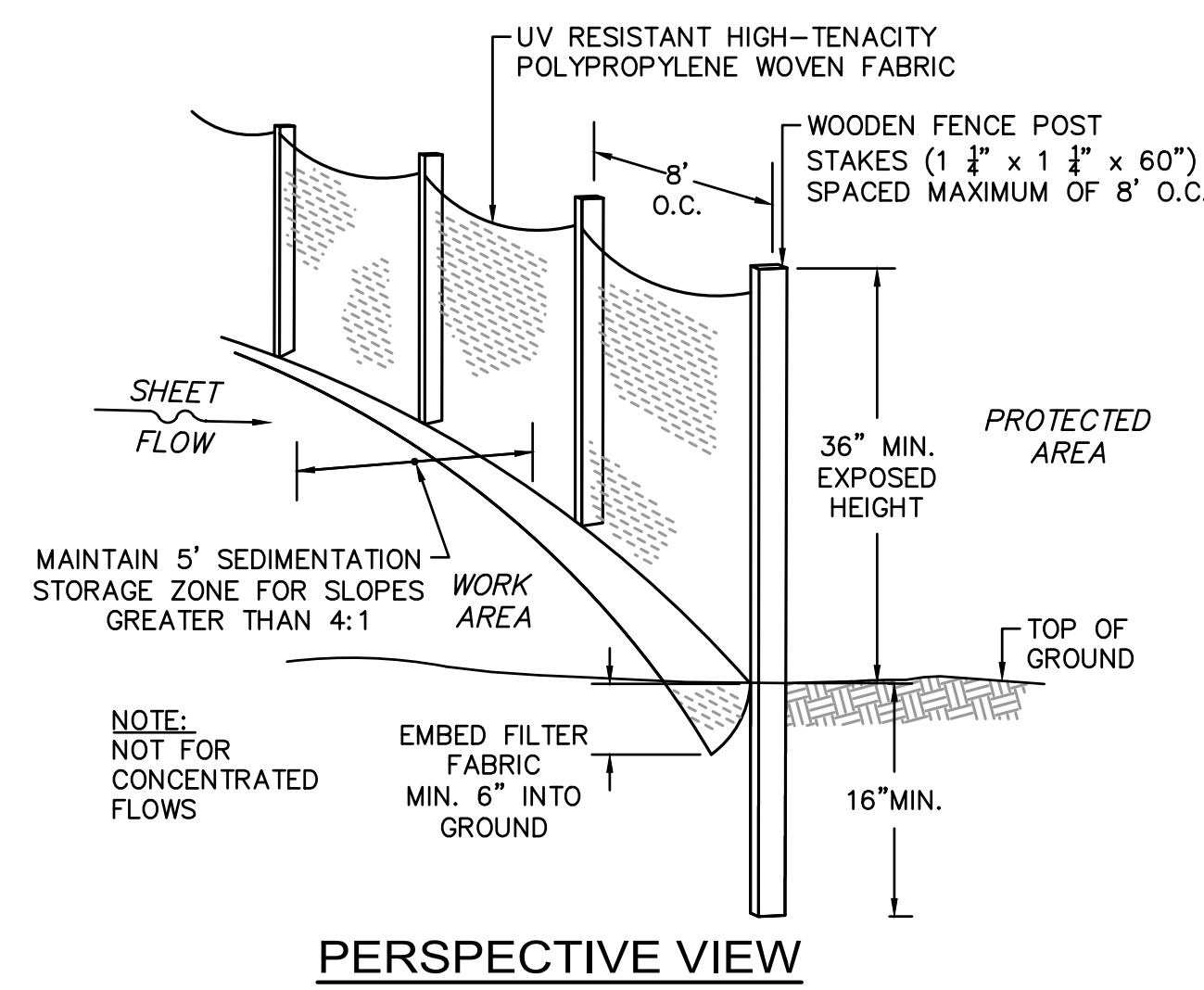

PERSPECTIVE VIEW

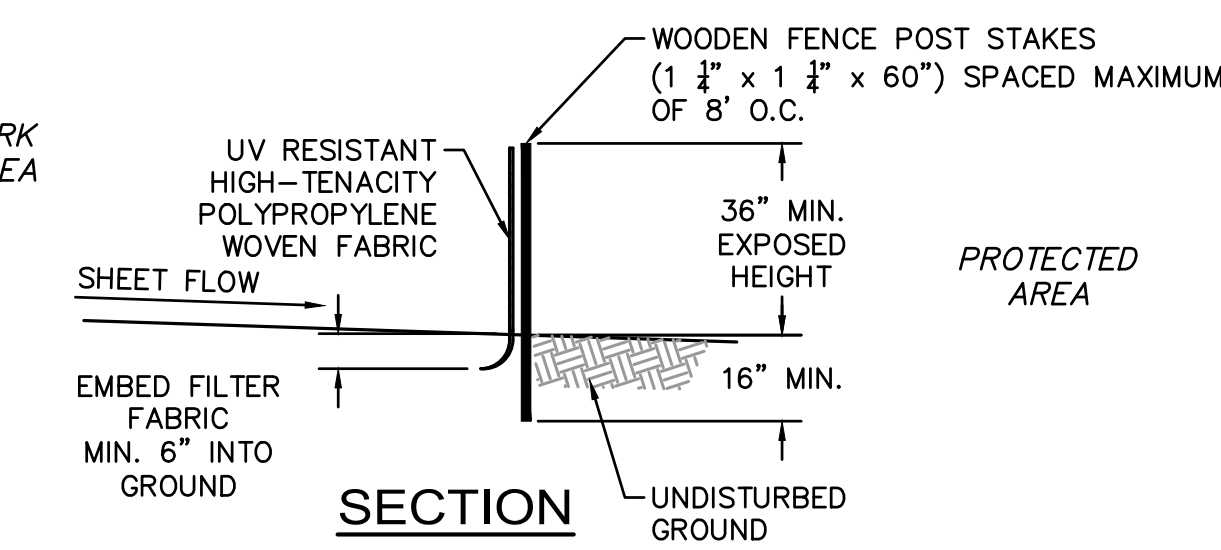

PERIMETER PROTECTION BARRIER (A)

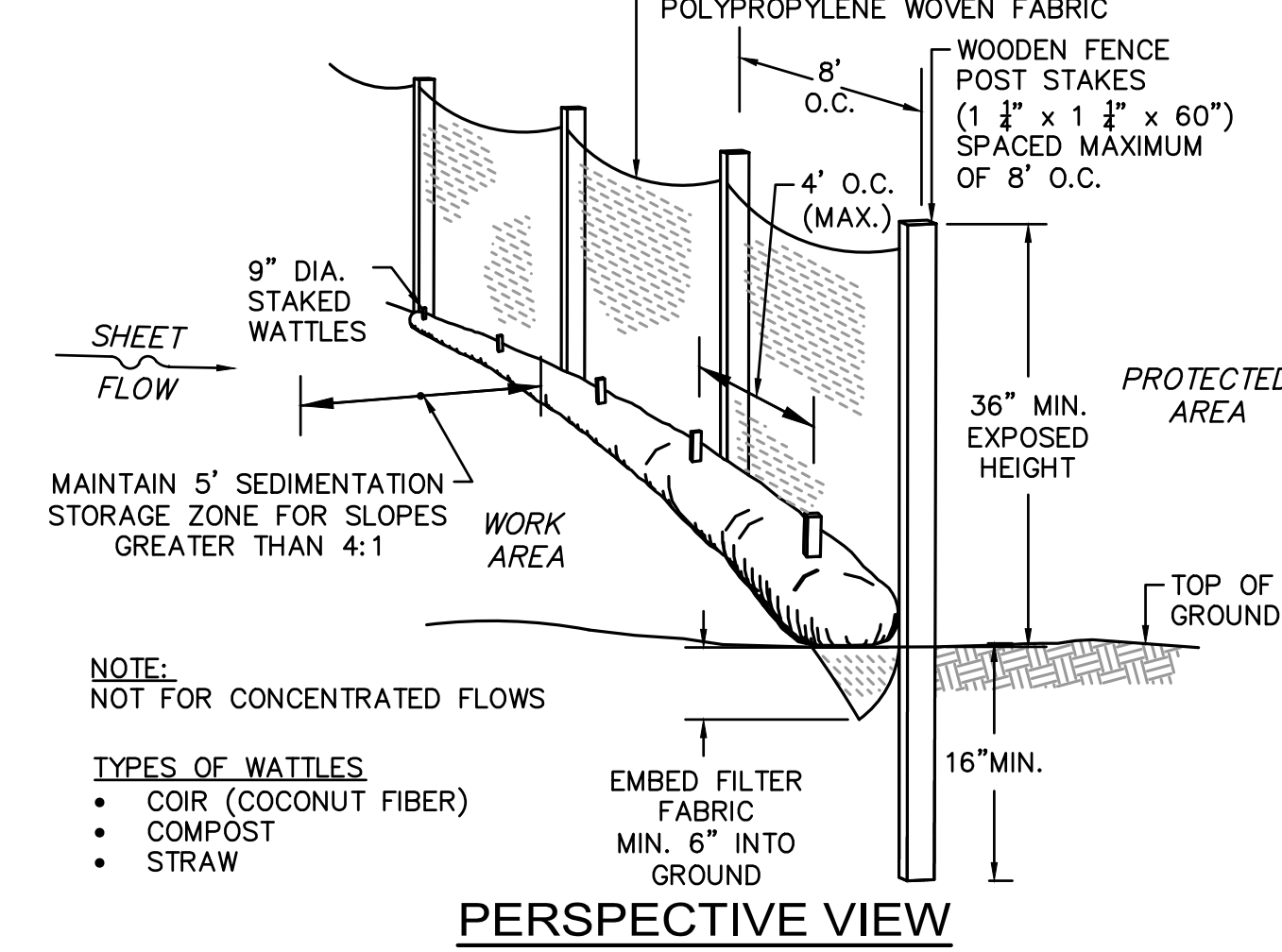

PERSPECTIVE VIEW

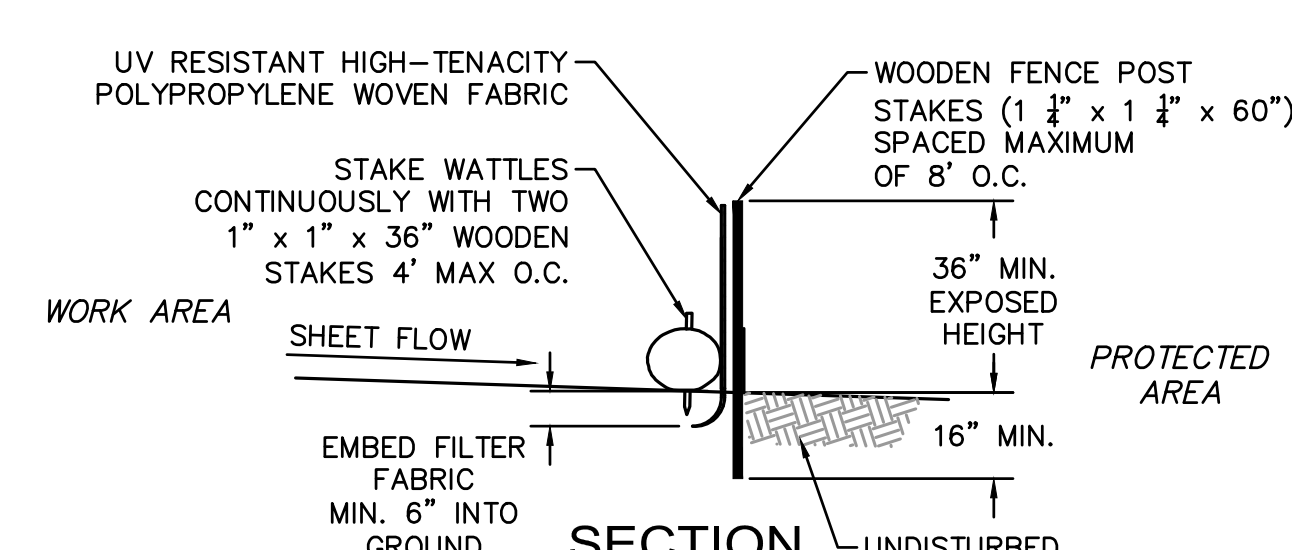

PERIMETER PROTECTION BARRIER (B) SILT FENCE DETAIL WITH WATTLES NOT TO SCALE

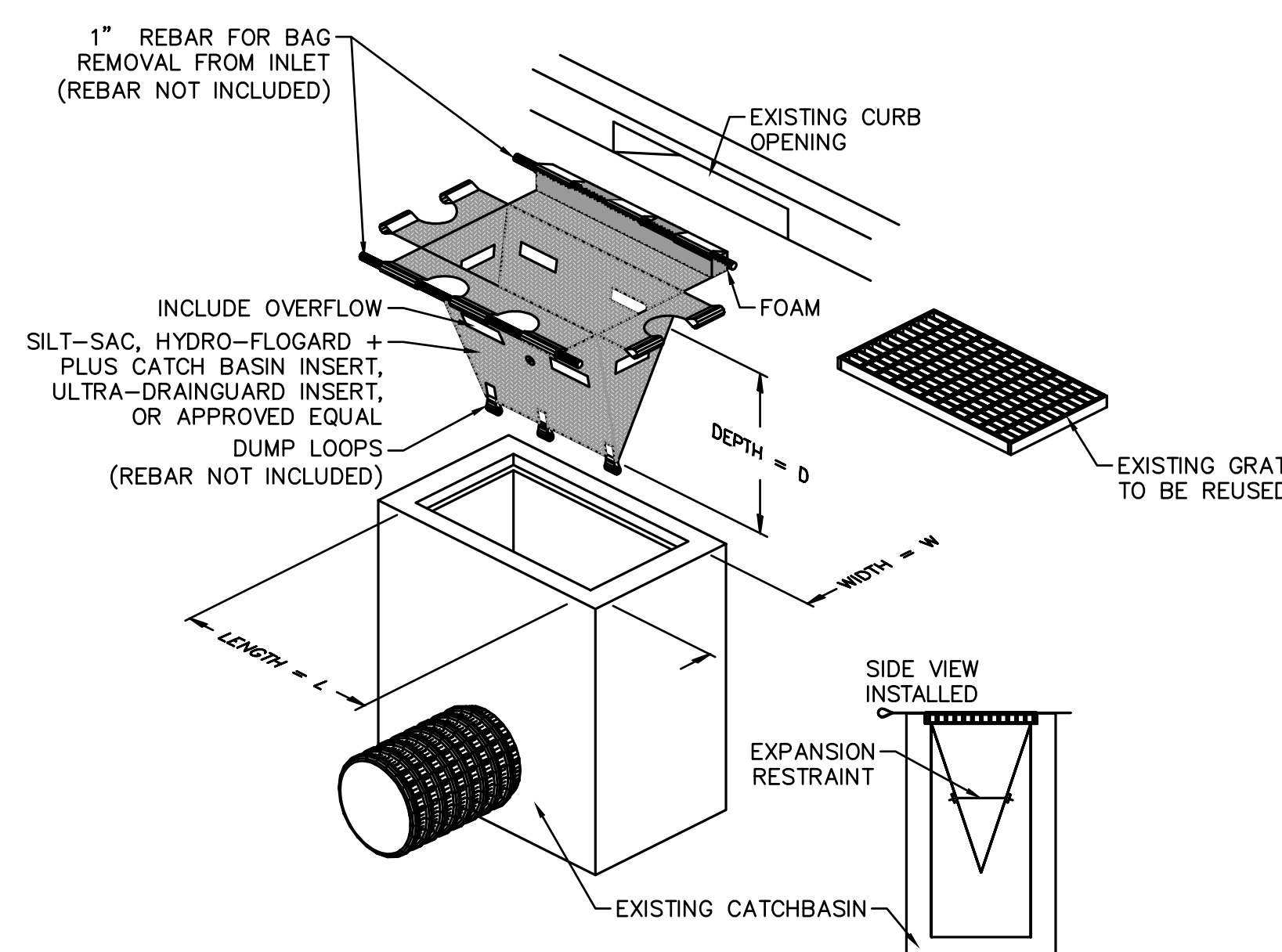

THIS METHOD OF INLET PROTECTION IS APPLICABLE WHERE THE INLET DRAINS SHEET, OVERLAND OR CONCENTRATED FLOWS (NOT GREATER THAN 1 CFS). THE METHOD CAN DRAIN FLAT AREA TO STEEP SLOPES. INLET CAPACITY WILL BE DECREASED WITH THIS METHOD AND THE CONTRACTOR SHALL EXPECT PONDING DURING HIGH FLOW EVENTS.

INLET PROTECTION ② CATCH BASIN W/ SILTING SACK NOT TO SCALE

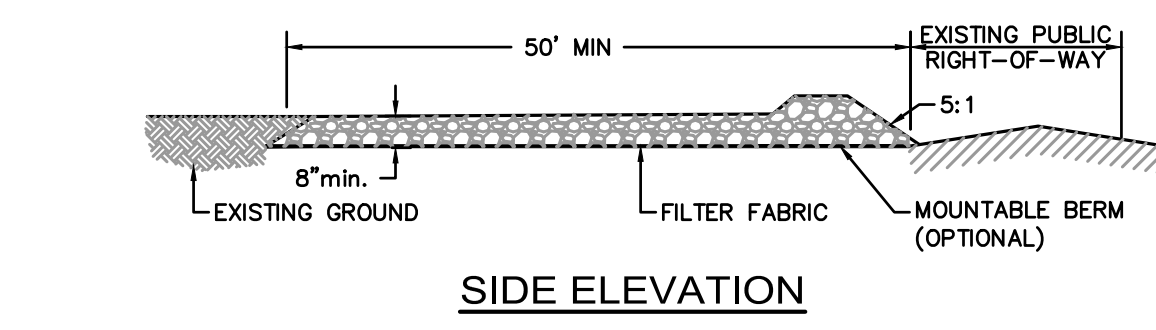

SIDE ELEVATION

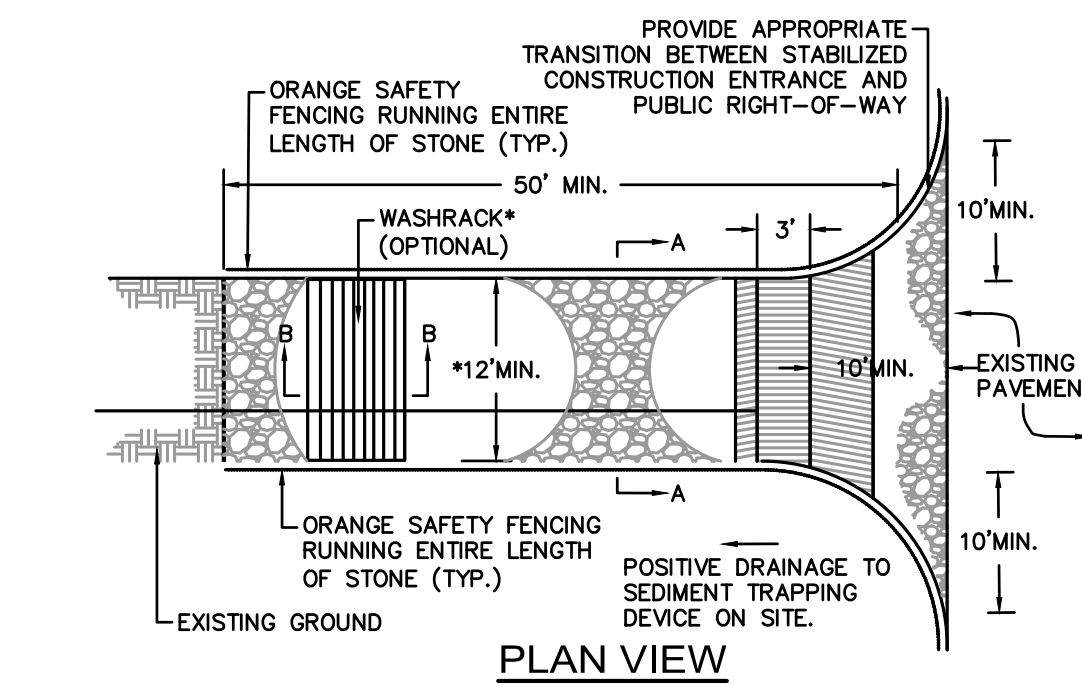

PLAN VIEW

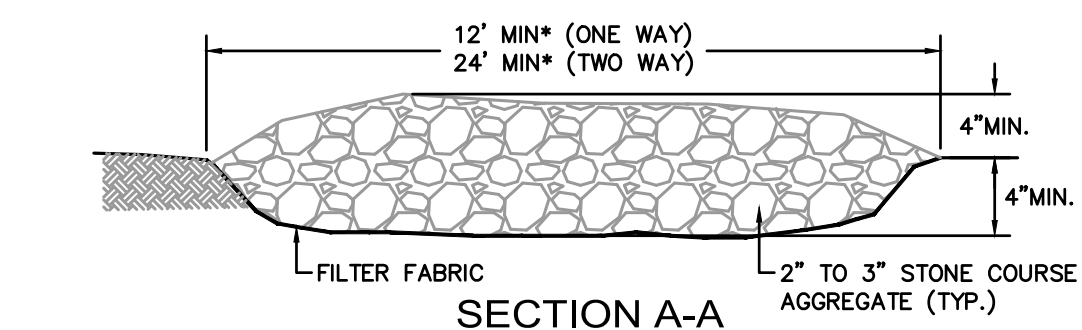

SECTION A-A

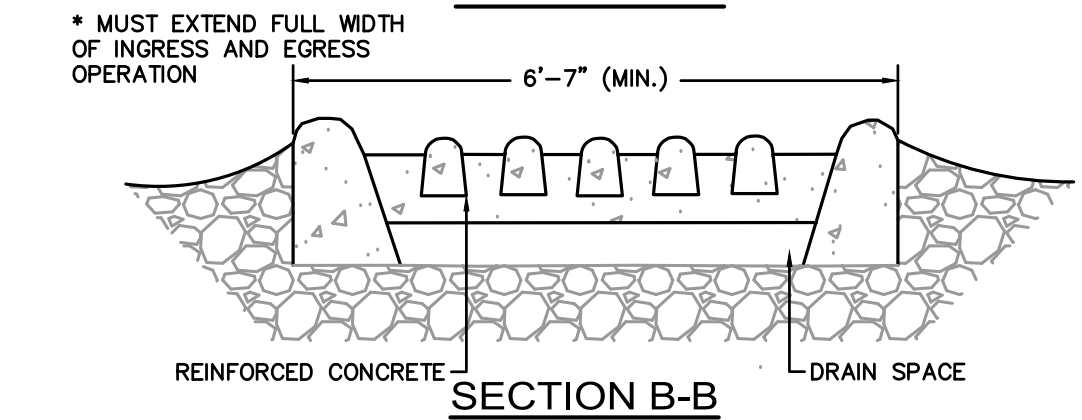

SECTION B-B

- CONSTRUCTION SPECIFICATIONS
- CONSTRUCTION SPECIFICATIONS
- LENGTH - GREATER THAN OR EQUAL TO 50 FEET
- WIDTH - TWELVE FOOT MINIMUM (ONE WAY), TWENTY FOUR FOOT MINIMUM (TWO WAY), BUT NOT LESS THAN THE FULL WIDTH AT POINTS WHERE INGRESS OR EGRESS OCCURS.
- SURFACE WATER - ALL SURFACE WATER FLOWING OR DIVERTED TOWARD CONSTRUCTION ENTRANCES SHALL BE PIPED ACROSS THE ENTRANCE. IF PIPING IS IMPRACTICAL, A MOUNTABLE BERM SHALL BE PERMITTED.
- THICKNESS - 8"
- MAINTENANCE - THE ENTRANCE SHALL BE MAINTAINED IN A CONDITION WHICH SHALL PREVENT TRACKING OR FLOWING OF SEDIMENT ONTO PUBLIC RIGHTS-OF-WAY. THIS MAY REQUIRE PERIODIC TOP DRESSING WITH ADDITIONAL STONE AS CONDITIONS DEMAND AND REPAIR OR CLEANOUT OF ANY MEASURES USED TO TRAP SEDIMENT. ALL SEDIMENT SPILLED, DROPPED, WASHED OR TRACKED ONTO PUBLIC RIGHTS-OF-WAY MUST BE REMOVED IMMEDIATELY.
- PERIODIC INSPECTION AND NEEDED MAINTENANCE SHALL BE PROVIDED.

STABILIZED CONSTRUCTION ENTRANCE

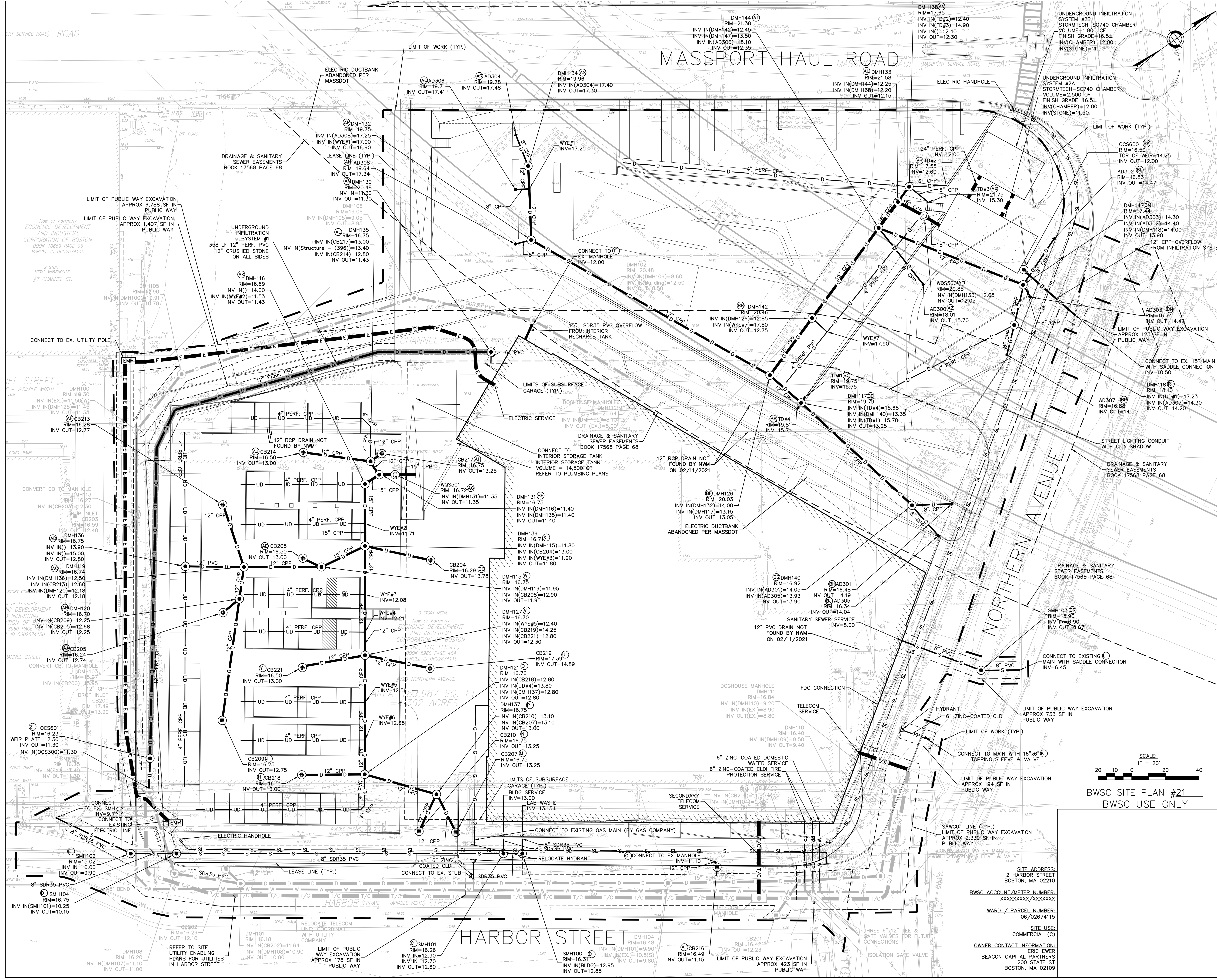

2 HARBOR

329 NORTHERN AVE
BOSTON, MA 02210

OWNER
BCP-CG HARBOR PROPERTY LLC
C/O BEACON CAPITAL PARTNERS, LLC
200 STATE STREET, FIFTH FLOOR
BOSTON, MA 02109

ARCHITECT
HANDEL ARCHITECTS, LLP
69 CANAL ST., 2ND FLOOR
BOSTON, MA 02214
T: 617.651.4790

CONSULTING ARCHITECT
STUDIO ENEE
460 HILLSIDE AVE
NEEDHAM, MA 02494
T: 781.858.3011

CONSULTING ARCHITECT
TRIA
21 DRYDOCK AVE, SUITE 330W
BOSTON, MA 02210
T: 617.530.1620

CIVIL ENGINEER
NITSCH ENGINEERING, INC.
2 CENTER PLAZA #430
BOSTON, MA 02108
T: 617.338.0063

MEP ENGINEER & CODE CONSULTANT
COSENTINI ASSOCIATES
101 FEDERAL ST #600
BOSTON, MA 02110
T: 617.748.7800

STRUCTURAL ENGINEER
DESIMONE CONSULTING ENGINEERS
31 MILK ST., SUITE 1016
BOSTON, MA 02109
T: 617.936.4492

LANDSCAPE ARCHITECT
KLOPPER MARTIN DESIGN GROUP
69 CANAL ST., 2ND FLOOR
BOSTON, MA 02214
T: 617.227.2560

ENVELOPE CONSULTANT
CBI CONSULTING, LLC
250 DORCHESTER AVE
BOSTON, MA 02127
T: 617.268.8977

GEOTECHNICAL
HALEY & ALDRICH, INC.
465 MEDFORD ST., SUITE 2200
BOSTON, MA 02129
T: 617.886.7400

NOT FOR CONSTRUCTION

NO.	DATE	ISSUANCE
1	12/20/2019	CONCEPT PRICING
2	12/15/2020	50% SCHEMATIC DESIGN
3	2/18/2021	100% SCHEMATIC DESIGN
4	4/16/2021	EARLY SITE PACKAGE

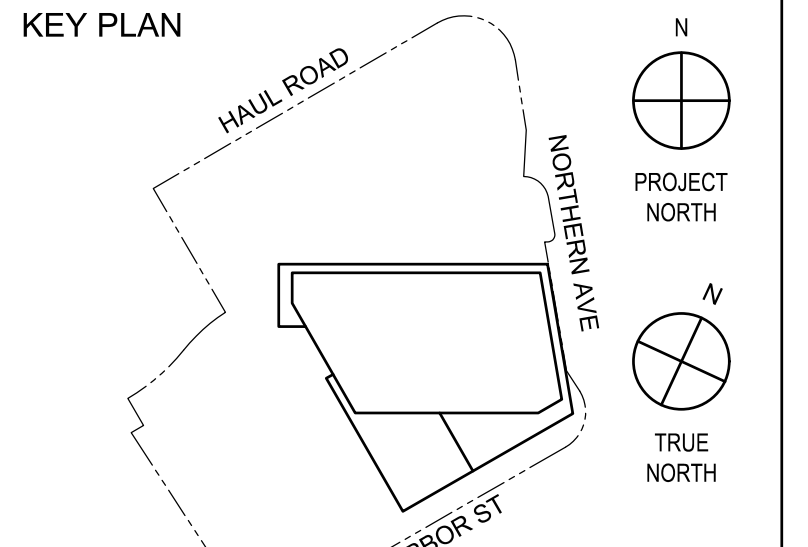

PROJECT DATUM: PROJ. 0'-0" = +16'-6" BCB

SCALE: 1" = 20'

PROJECT NO: 1550

SEAL & SIGNATURE

DRAWING TITLE: SITE UTILITY PLAN

DRAWING NO: C-300

DRAWING TITLE: SITE UTILITY PLAN

DRAWING NO: C-300

2 HARBOR

329 NORTHERN AVE
BOSTON, MA 02210

OWNER
BCP-CG HARBOR PROPERTY LLC
C/O BEACON CAPITAL PARTNERS, LLC
200 STATE STREET, FIFTH FLOOR
BOSTON, MA 02109

ARCHITECT
HANDEL ARCHITECTS, LLP
69 CANAL ST, 2ND FLOOR
BOSTON, MA 02114
T: 617.651.4790

CONSULTING ARCHITECT
STUDIO ENEE
460 HILLSIDE AVE
NEEDHAM, MA 02494
T: 781.858.3011

CONSULTING ARCHITECT
TRIA
21 DRYDOCK AVE, SUITE 330W
BOSTON, MA 02210
T: 617.530.1620

CIVIL ENGINEER
NITSCH ENGINEERING, INC.
2 CENTER PLAZA #430
BOSTON, MA 02108
T: 617.338.0063

MEP ENGINEER & CODE CONSULTANT
COSENTINI ASSOCIATES
101 FEDERAL ST #610
BOSTON, MA 02110
T: 617.748.7800

STRUCTURAL ENGINEER
DESIMONE CONSULTING ENGINEERS
31 MILK ST, SUITE 1016
BOSTON, MA 02109
T: 617.936.4492

LANDSCAPE ARCHITECT
KLOPPER MARTIN DESIGN GROUP
69 CANAL ST, 2ND FLOOR
BOSTON, MA 02114
T: 617.227.2560

ENVELOPE CONSULTANT
CBI CONSULTING, LLC
250 DORCHESTER AVE
BOSTON, MA 02127
T: 617.268.8977

GEOTECHNICAL
HALEY & ALDRICH, INC.
465 MEDFORD ST, SUITE 2200
BOSTON, MA 02129
T: 617.886.7400

NOT FOR CONSTRUCTION

NO.	DATE	ISSUANCE
1	12/20/2019	CONCEPT PRICING
2	12/15/2020	50% SCHEMATIC DESIGN
3	2/18/2021	100% SCHEMATIC DESIGN
4	4/16/2021	EARLY SITE PACKAGE

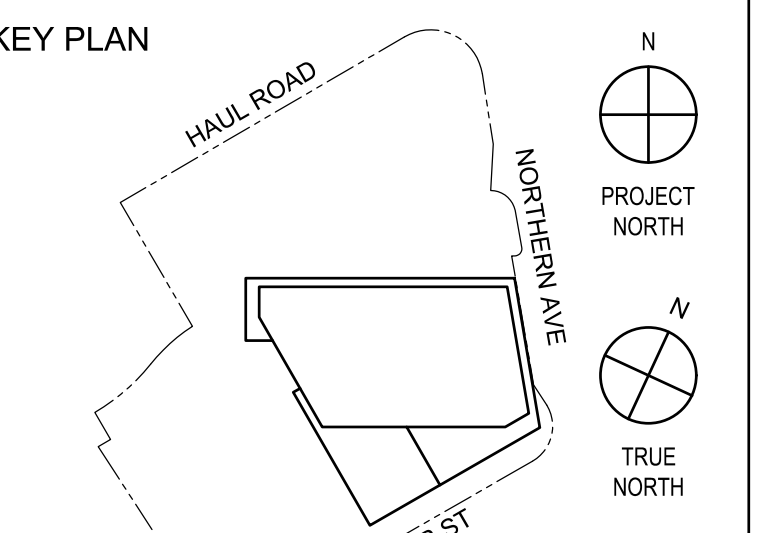

PROJECT DATUM: PROJ. 0'-0" = +16'-6" BCB
SCALE: 1" = 20'
PROJECT NO: 1550
SEAL & SIGNATURE



DRAWING TITLE:
**EARLY SITE PACKAGE
UTILITY PLAN**

DRAWING NO:
C-300A

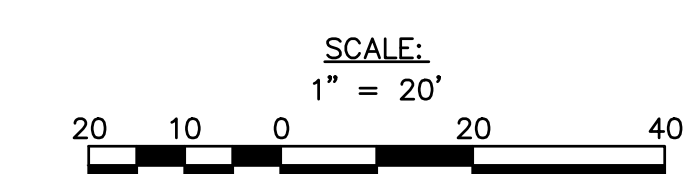
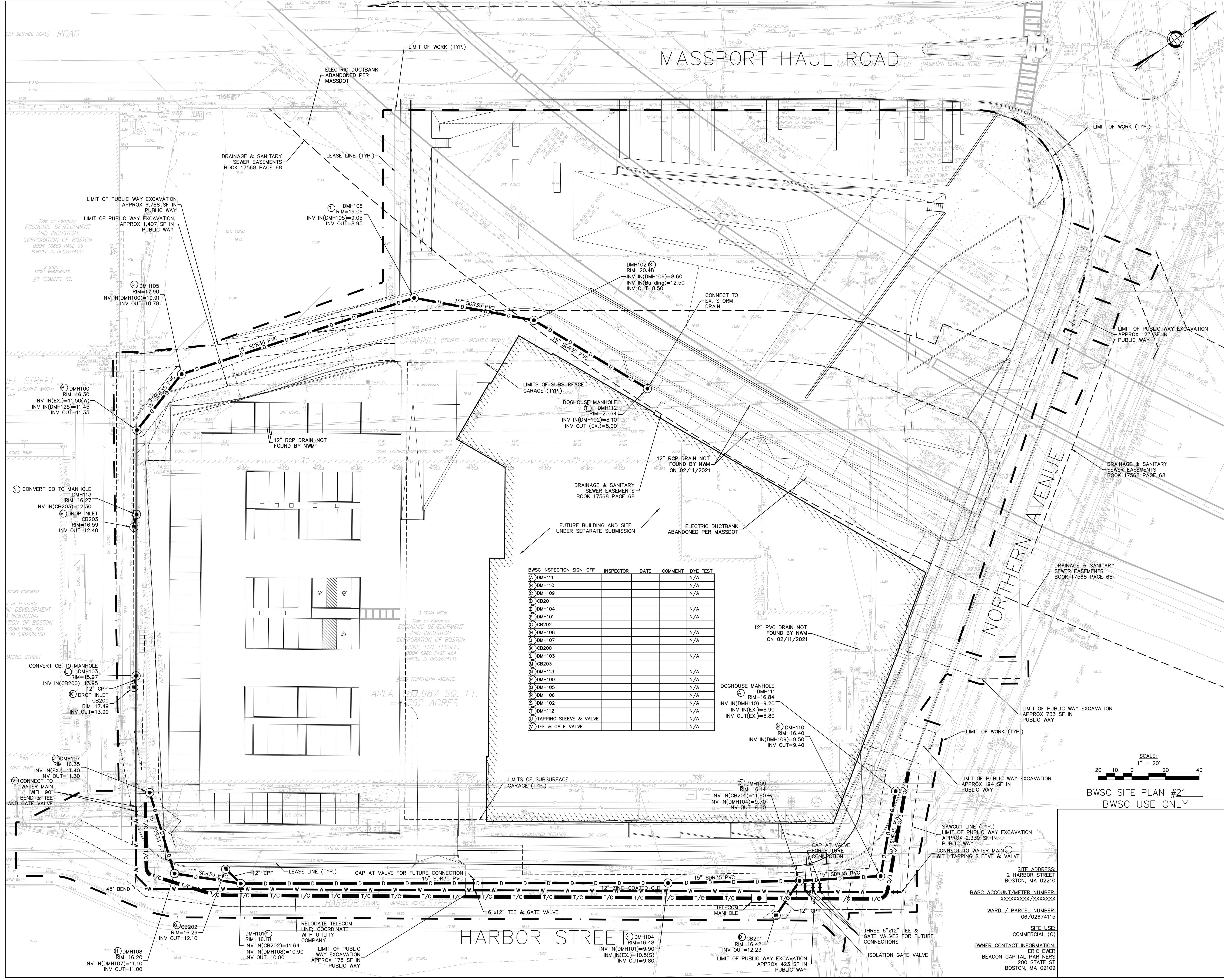

BWSC SITE PLAN #21
BWSC USE ONLY

SITE ADDRESS:
2 HARBOR STREET
BOSTON, MA 02210
BWSC ACCOUNT/METER NUMBER:
XXXXXXXX/XXXXXX
WARD / PARCEL NUMBER:
06/02674115
SITE USE:
COMMERCIAL (C)
OWNER CONTACT INFORMATION:
ERIC EWER
BEACON CAPITAL PARTNERS
200 STATE ST
BOSTON, MA 02109

2 HARBOR

329 NORTHERN AVE
BOSTON, MA 02210

OWNER
BCP-CG HARBOR PROPERTY LLC
C/O BEACON CAPITAL PARTNERS, LLC
200 STATE STREET, FIFTH FLOOR
BOSTON, MA 02109

ARCHITECT
HANDEL ARCHITECTS, LLP
69 CANAL ST, 2ND FLOOR
BOSTON, MA 02114
T: 617.651.4790

CONSULTING ARCHITECT
STUDIO ENEE
460 HILLSIDE AVE
NEEDHAM, MA 02494
T: 781.858.3011

CONSULTING ARCHITECT
TRIA
21 DRYDOCK AVE, SUITE 330W
BOSTON, MA 02210
T: 617.530.1620

CIVIL ENGINEER
NITSCH ENGINEERING, INC.
2 CENTER PLAZA #430
BOSTON, MA 02108
T: 617.338.0063

MEP ENGINEER & CODE CONSULTANT
COSENTINI ASSOCIATES
101 FEDERAL ST #600
BOSTON, MA 02110
T: 617.748.7800

STRUCTURAL ENGINEER
DESIMONE CONSULTING ENGINEERS
31 MILK ST, SUITE 1016
BOSTON, MA 02109
T: 617.936.4492

LANDSCAPE ARCHITECT
KLOPFER MARTIN DESIGN GROUP
69 CANAL ST, 2ND FLOOR
BOSTON, MA 02114
T: 617.227.2560

ENVELOPE CONSULTANT
CBI CONSULTING, LLC
250 DORCHESTER AVE
BOSTON, MA 02127
T: 617.268.8977

GEOTECHNICAL
HALEY & ALDRICH, INC.
465 MEDFORD ST, SUITE 2200
BOSTON, MA 02129
T: 617.886.7400

NOT FOR CONSTRUCTION

NO.	DATE	ISSUANCE
1	12/20/2019	CONCEPT PRICING
2	12/15/2020	50% SCHEMATIC DESIGN
3	2/18/2021	100% SCHEMATIC DESIGN
4	4/16/2021	EARLY SITE PACKAGE

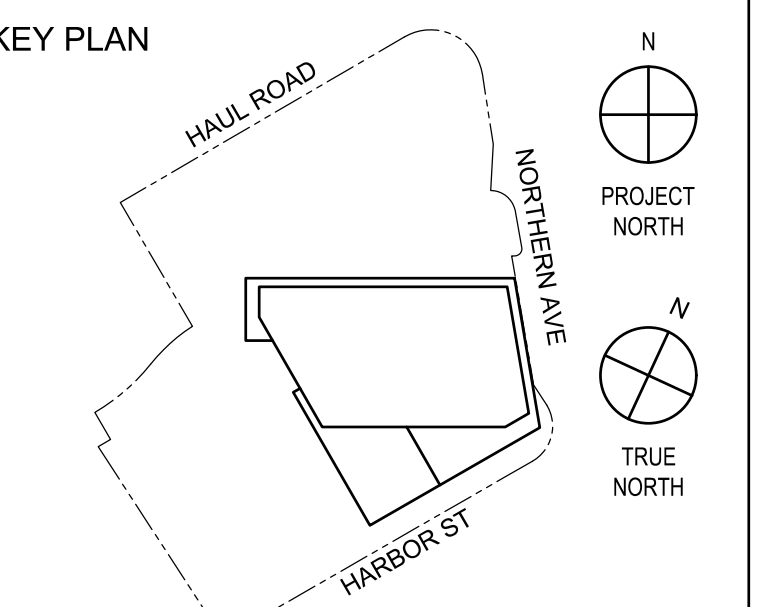

PROJECT DATUM: PROJ. 0'-0" = +16'-6" BCB
SCALE: AS SHOWN
PROJECT NO: 1550
SEAL & SIGNATURE



DRAWING TITLE:

HARBOR STREET
DRAIN PROFILE

DRAWING NO:

C-301A

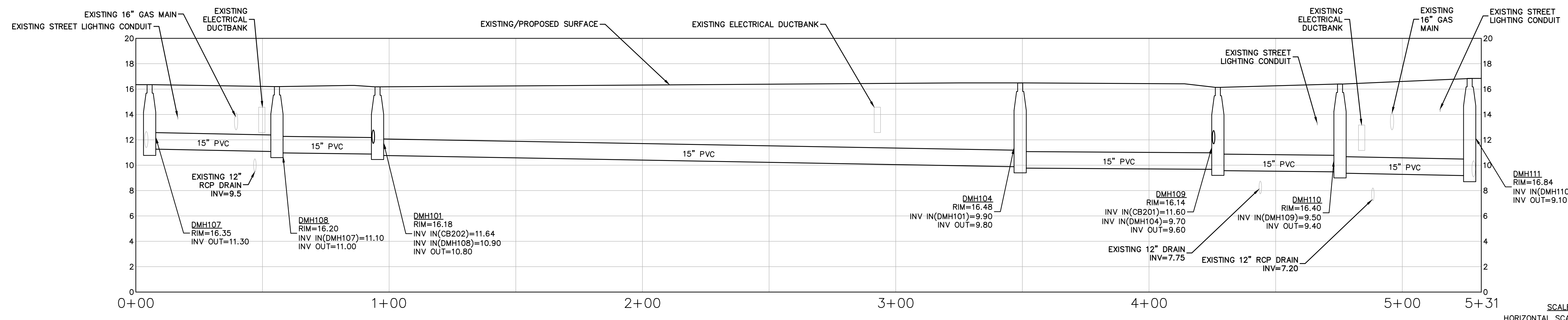
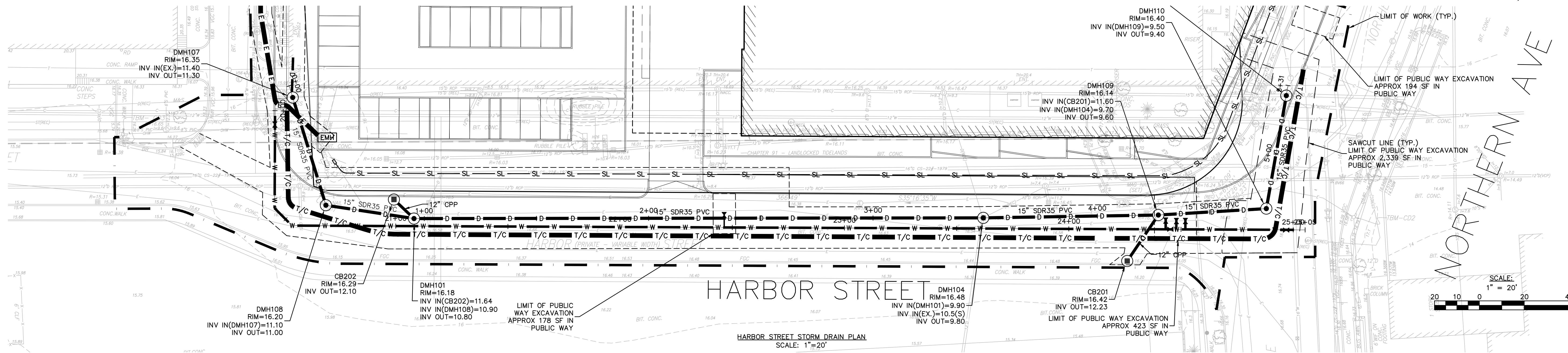

HARBOR STREET STORM DRAIN PROFILE
HORIZONTAL SCALE: 1" = 20'
VERTICAL SCALE: 1" = 4'

BWSC SITE PLAN #21
BWSC USE ONLY

SITE ADDRESS:
2 HARBOR STREET
BOSTON, MA 02210
BWSC ACCOUNT/METER NUMBER:
XXXXXXXX/XXXXXX
WARD / PARCEL NUMBER:
06/02674115
SITE USE:
COMMERCIAL (C)
OWNER CONTACT INFORMATION:
ERIC EWER
BEACON CAPITAL PARTNERS
200 STATE ST
BOSTON, MA 02109

2 HARBOR

329 NORTHERN AVE
BOSTON, MA 02210

OWNER
BCP-CG HARBOR PROPERTY LLC
C/O BEACON CAPITAL PARTNERS, LLC
200 STATE STREET, FIFTH FLOOR
BOSTON, MA 02109

ARCHITECT
HANDEL ARCHITECTS, LLP
69 CANAL ST, 2ND FLOOR
BOSTON, MA 02114
T: 617.651.4790

CONSULTING ARCHITECT
STUDIO ENÉE
460 HILLSIDE AVE
NEEDHAM, MA 02494
T: 781.858.3011

CONSULTING ARCHITECT
TRIA
21 DRYDOCK AVE, SUITE 330W
BOSTON, MA 02210
T: 617.530.1620

CIVIL ENGINEER
NITSCH ENGINEERING, INC.
2 CENTER PLAZA #430
BOSTON, MA 02108
T: 617.338.0063

MEP ENGINEER & CODE CONSULTANT
COSENTINI ASSOCIATES
101 FEDERAL ST #600
BOSTON, MA 02110
T: 617.748.7800

STRUCTURAL ENGINEER
DESIMONE CONSULTING ENGINEERS
31 MILK ST, SUITE 1016
BOSTON, MA 02109
T: 617.836.4492

LANDSCAPE ARCHITECT
KLOPFER MARTIN DESIGN GROUP
69 CANAL ST, 2ND FLOOR
BOSTON, MA 02114
T: 617.227.2560

ENVELOPE CONSULTANT
CBI CONSULTING, LLC
250 DORCHESTER AVE
BOSTON, MA 02127
T: 617.268.8977

GEOTECHNICAL
HALEY & ALDRICH, INC.
465 MEDFORD ST, SUITE 2200
BOSTON, MA 02129
T: 617.886.7400

NOT FOR CONSTRUCTION

NO.	DATE	ISSUANCE
1	12/20/2019	CONCEPT PRICING
2	12/15/2020	50% SCHEMATIC DESIGN
3	2/18/2021	100% SCHEMATIC DESIGN
4	4/16/2021	EARLY SITE PACKAGE

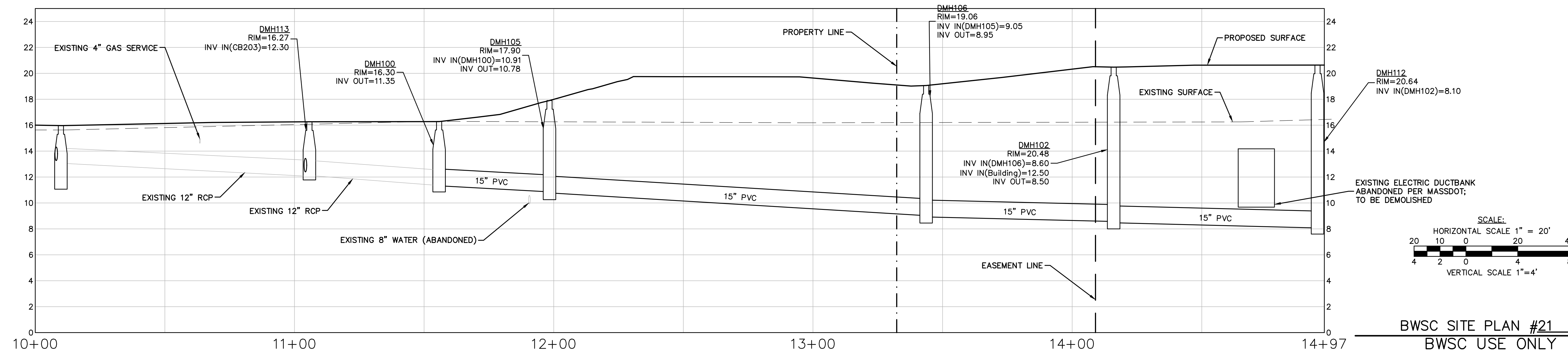
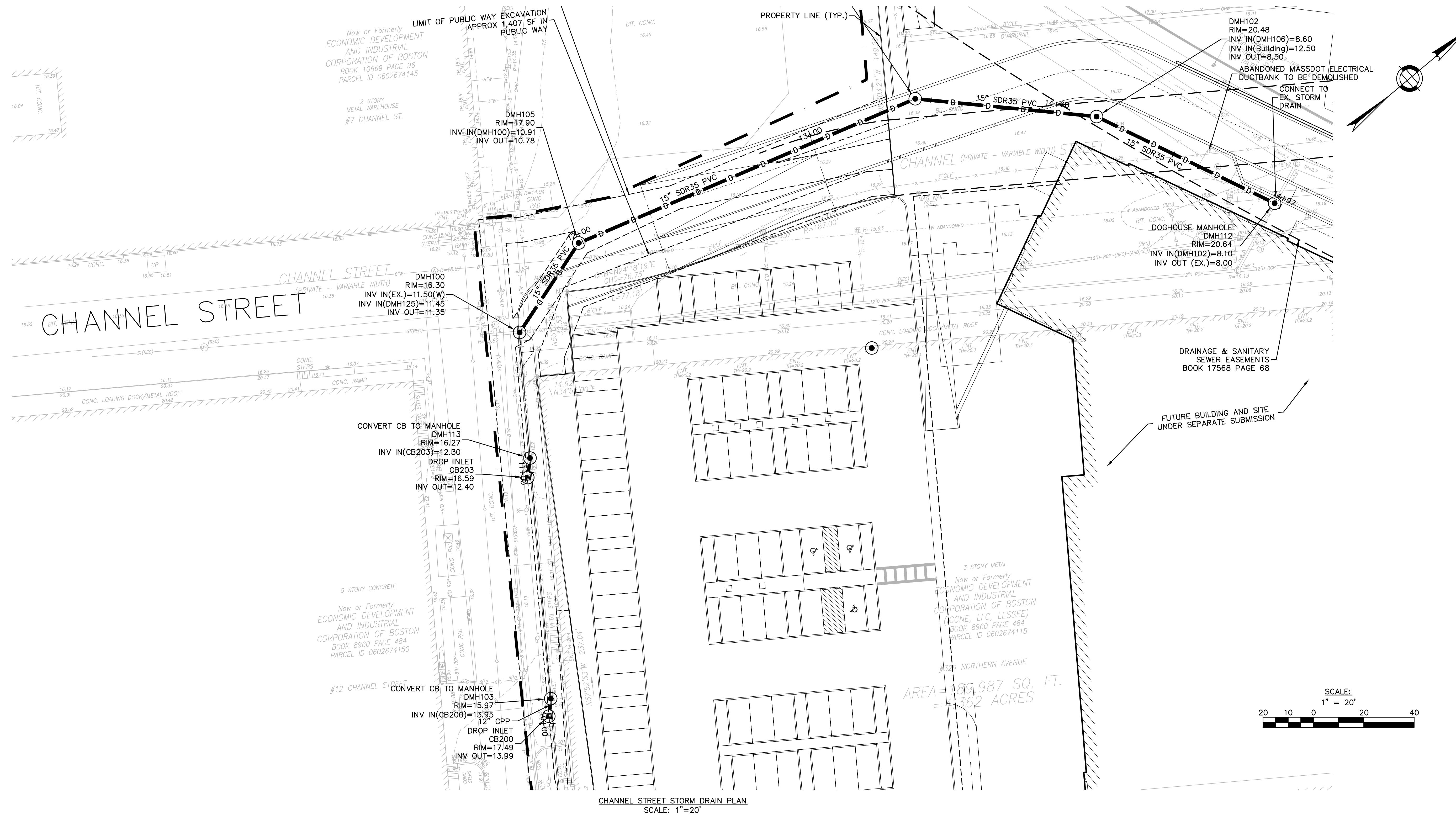

CHANNEL STREET STORM DRAIN PROFILE
HORIZONTAL SCALE: 1"=20'
VERTICAL SCALE: 1"=4'

BWSC SITE PLAN #21
BWSC USE ONLY

SITE ADDRESS:
2 HARBOR STREET
BOSTON, MA 02210

BWSC ACCOUNT/METER NUMBER:
XXXXXXXXXX/XXXXXXXX

WARD / PARCEL NUMBER:
06/02674115

SITE USE:
COMMERCIAL (C)

OWNER CONTACT INFORMATION:
ERIC EWER
BEACON CAPITAL PARTNERS
200 STATE ST
BOSTON, MA 02109

KEY PLAN

PROJECT DATUM: PROJ. 0'-0" = +16'-6" BCB
SCALE: AS SHOWN
PROJECT NO: 1550
SEAL & SIGNATURE

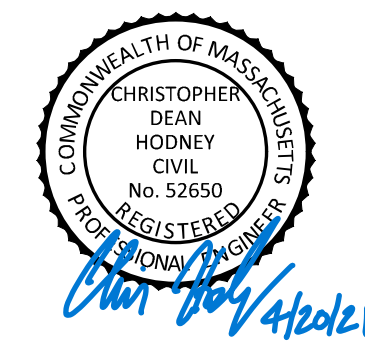

DRAWING TITLE:
**CHANNEL STREET
DRAIN PROFILE**

DRAWING NO:
C-302A

2 HARBOR

329 NORTHERN AVE
BOSTON, MA 02210

OWNER
BCP-CG HARBOR PROPERTY LLC
C/O BEACON CAPITAL PARTNERS, LLC
200 STATE STREET, FIFTH FLOOR
BOSTON, MA 02109

ARCHITECT
HANDEL ARCHITECTS, LLP
69 CANAL ST, 2ND FLOOR
BOSTON, MA 02114
T: 617.651.4790

CONSULTING ARCHITECT
STUDIO ENEE
460 HILLSIDE AVE
NEEDHAM, MA 02494
T: 781.858.3011

CONSULTING ARCHITECT
TRIA
21 DRYDOCK AVE, SUITE 330W
BOSTON, MA 02210
T: 617.530.1620

CIVIL ENGINEER
NITSCH ENGINEERING, INC.
2 CENTER PLAZA #430
BOSTON, MA 02108
T: 617.338.0063

MEP ENGINEER & CODE CONSULTANT
COSENTINI ASSOCIATES
101 FEDERAL ST #600
BOSTON, MA 02110
T: 617.748.7800

STRUCTURAL ENGINEER
DESIMONE CONSULTING ENGINEERS
31 MILK ST, SUITE 1016
BOSTON, MA 02109
T: 617.836.4492

LANDSCAPE ARCHITECT
KLOPFER MARTIN DESIGN GROUP
69 CANAL ST, 2ND FLOOR
BOSTON, MA 02114
T: 617.227.2560

ENVELOPE CONSULTANT
CBI CONSULTING, LLC
250 DORCHESTER AVE
BOSTON, MA 02127
T: 617.268.8977

GEOTECHNICAL
HALEY & ALDRICH, INC.
465 MEDFORD ST, SUITE 2200
BOSTON, MA 02129
T: 617.886.7400

NOT FOR CONSTRUCTION

NO.	DATE	ISSUANCE
1	12/20/2019	CONCEPT PRICING
2	12/15/2020	50% SCHEMATIC DESIGN
3	2/18/2021	100% SCHEMATIC DESIGN
4	4/16/2021	EARLY SITE PACKAGE

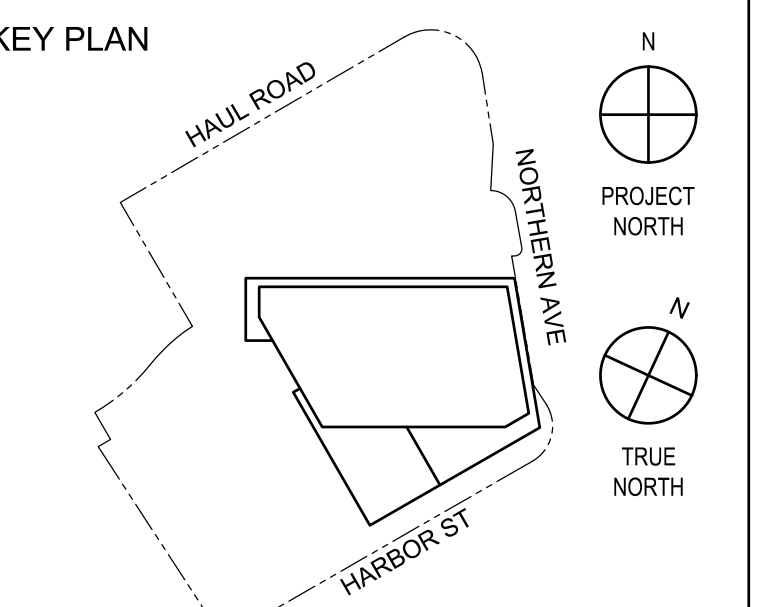

PROJECT DATUM: PROJ. 0'-0" = +16'-6" BCB
SCALE: AS SHOWN
PROJECT NO: 1550
SEAL & SIGNATURE



DRAWING TITLE:

HARBOR STREET
WATER PROFILE

DRAWING NO:

C-303A

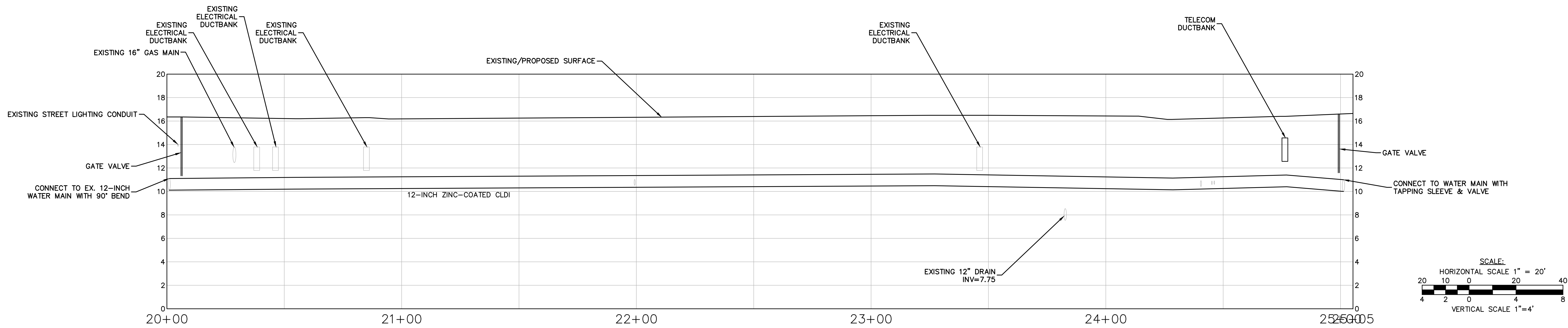
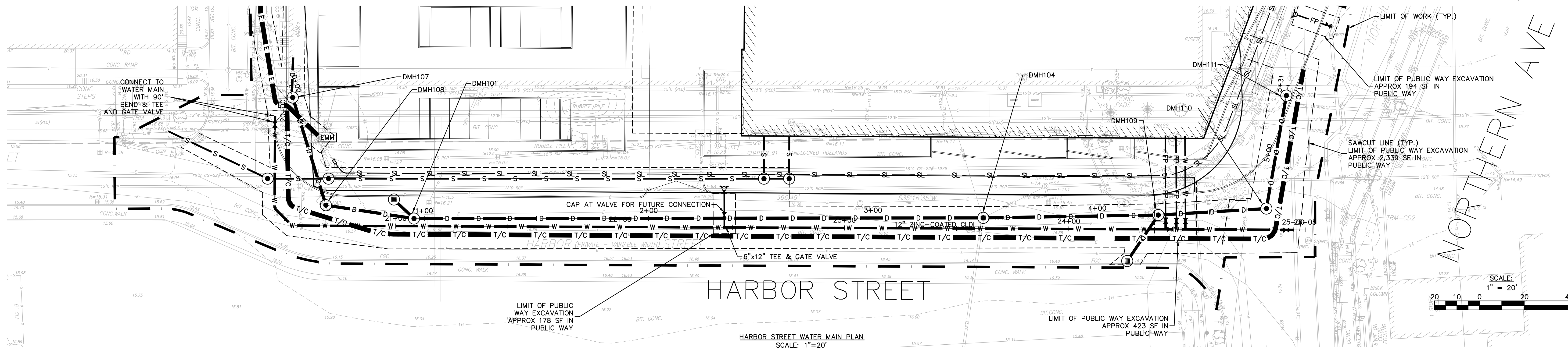

HARBOR STREET WATER MAIN PROFILE
HORIZONTAL SCALE: 1"=20'
VERTICAL SCALE: 1"=4'

BWSC SITE PLAN #21
BWSC USE ONLY

SITE ADDRESS:
2 HARBOR STREET
BOSTON, MA 02210
BWSC ACCOUNT/METER NUMBER:
XXXXXXXX/XXXXXX
WARD / PARCEL NUMBER:
06/02674115
SITE USE:
COMMERCIAL (C)
OWNER CONTACT INFORMATION:
ERIC EWER
BEACON CAPITAL PARTNERS
200 STATE ST
BOSTON, MA 02109

2 HARBOR

329 NORTHERN AVE
BOSTON, MA 02210

OWNER
BCP-CG HARBOR PROPERTY LLC
C/O BEACON CAPITAL PARTNERS, LLC
200 STATE STREET, FIFTH FLOOR
BOSTON, MA 02109

ARCHITECT
HANDEL ARCHITECTS, LLP
69 CANAL ST., 2ND FLOOR
BOSTON, MA 02114
T: 617.651.4790

CONSULTING ARCHITECT
STUDIO ENÉE
460 HILLSIDE AVE
NEEDHAM, MA 02494
T: 781.858.3011

CONSULTING ARCHITECT
TRIA
21 DRYDOCK AVE, SUITE 330W
BOSTON, MA 02110
T: 617.530.1620

CIVIL ENGINEER
NITSCH ENGINEERING, INC.
2 CENTER PLAZA #430
BOSTON, MA 02108
T: 617.338.0063

MEP ENGINEER & CODE CONSULTANT
COSENTINI ASSOCIATES
101 FEDERAL ST #600
BOSTON, MA 02110
T: 617.748.7800

STRUCTURAL ENGINEER
DESIMONE CONSULTING ENGINEERS
31 MILK ST., SUITE 1016
BOSTON, MA 02109
T: 617.936.4492

LANDSCAPE ARCHITECT
KLOPPER MARTIN DESIGN GROUP
69 CANAL ST., 2ND FLOOR
BOSTON, MA 02114
T: 617.227.2560

ENVELOPE CONSULTANT
CBI CONSULTING, LLC
250 DORCHESTER AVE
BOSTON, MA 02127
T: 617.268.8977

GEOTECHNICAL
HALEY & ALDRICH, INC.
465 MEDFORD ST., SUITE 2200
BOSTON, MA 02129
T: 617.886.7400

NOT FOR CONSTRUCTION

NO.	DATE	ISSUANCE
1	12/20/2019	CONCEPT PRICING
2	12/15/2020	50% SCHEMATIC DESIGN
3	2/18/2021	100% SCHEMATIC DESIGN
4	4/16/2021	EARLY SITE PACKAGE

KEY PLAN

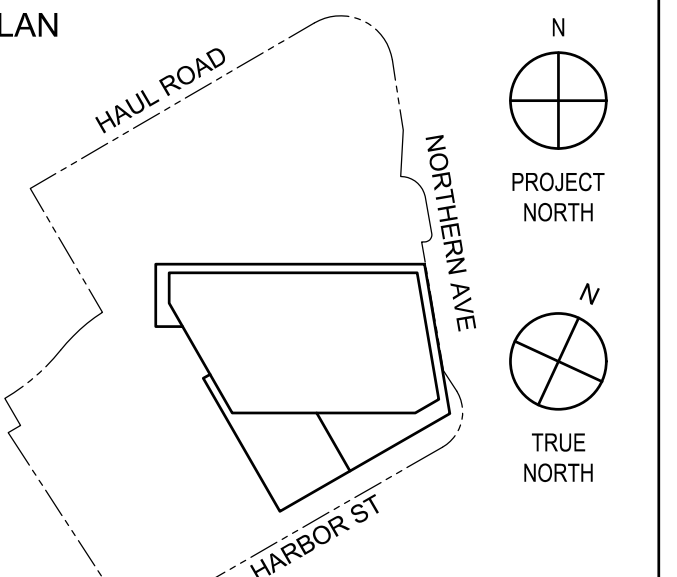

PROJECT DATUM: PROJ. 0'-0" = +16'-6" BCB
SCALE: 1" = 20'
PROJECT NO: 1550
SEAL & SIGNATURE



DRAWING TITLE:

SITE LAYOUT PLAN

DRAWING NO:

C-400

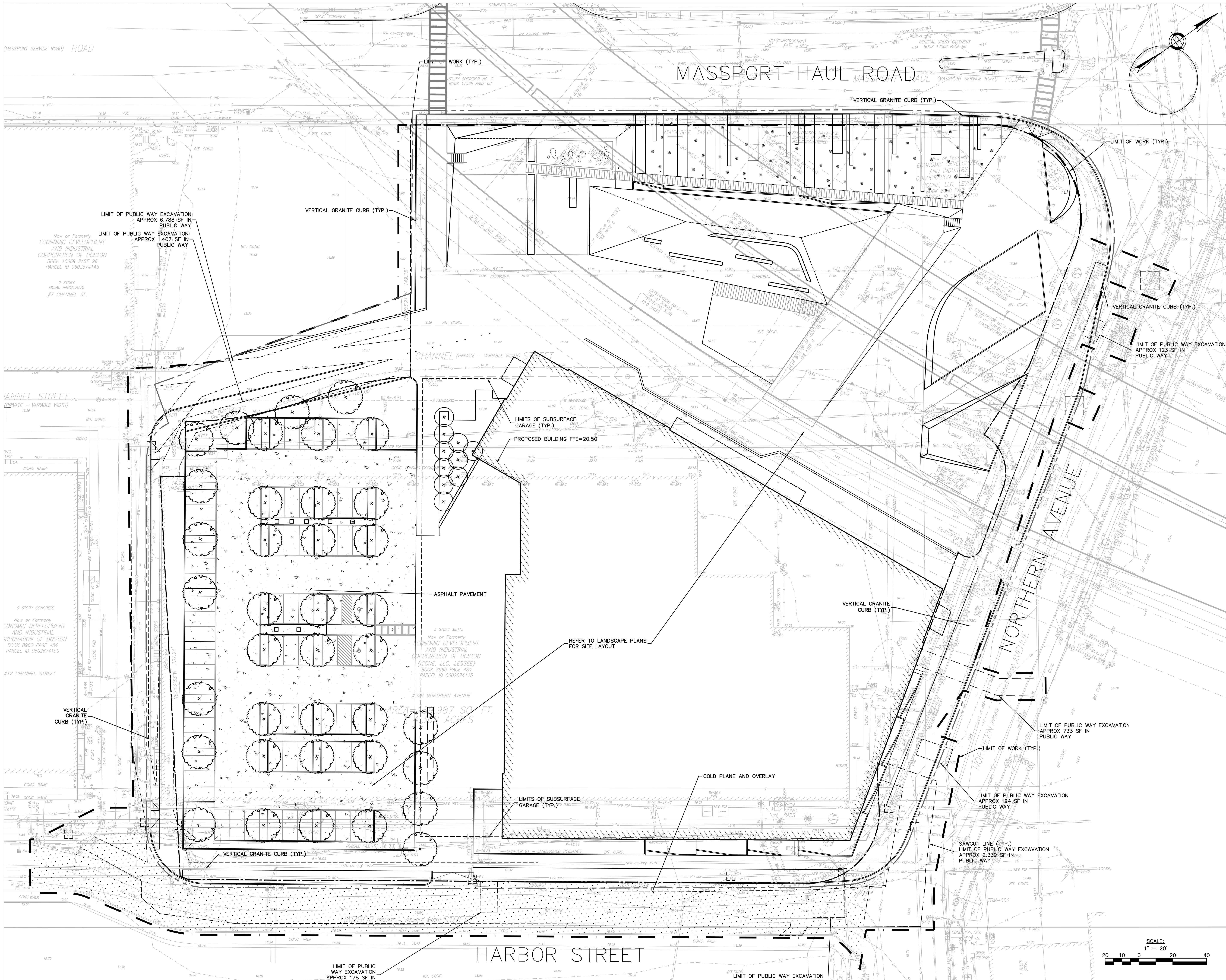

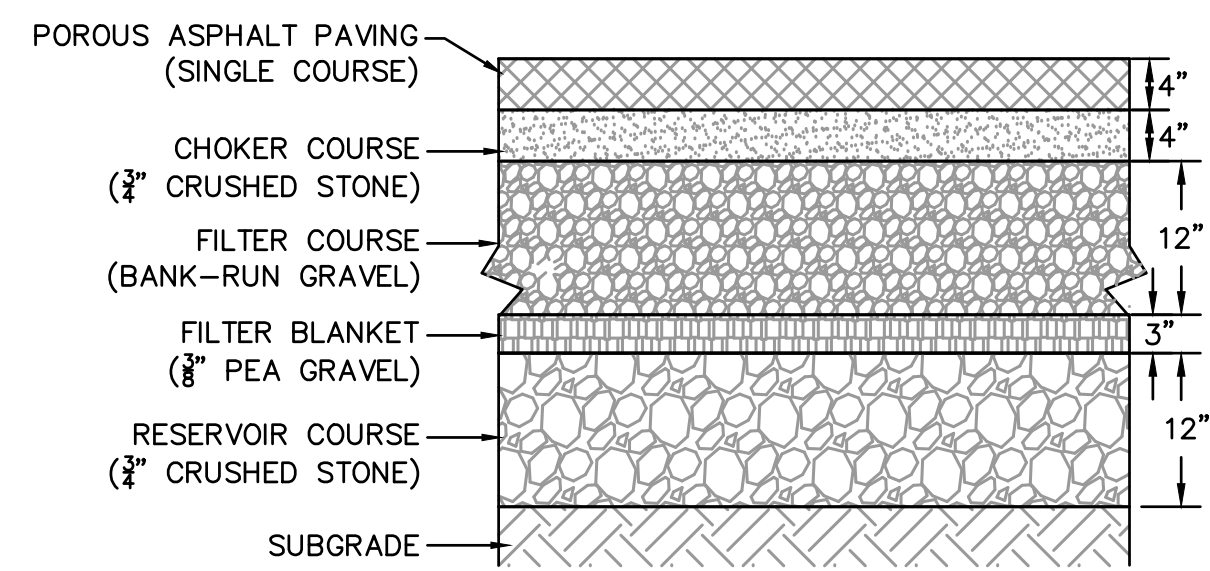

TYPICAL POROUS ASPHALT SECTION DETAIL
NOT TO SCALE

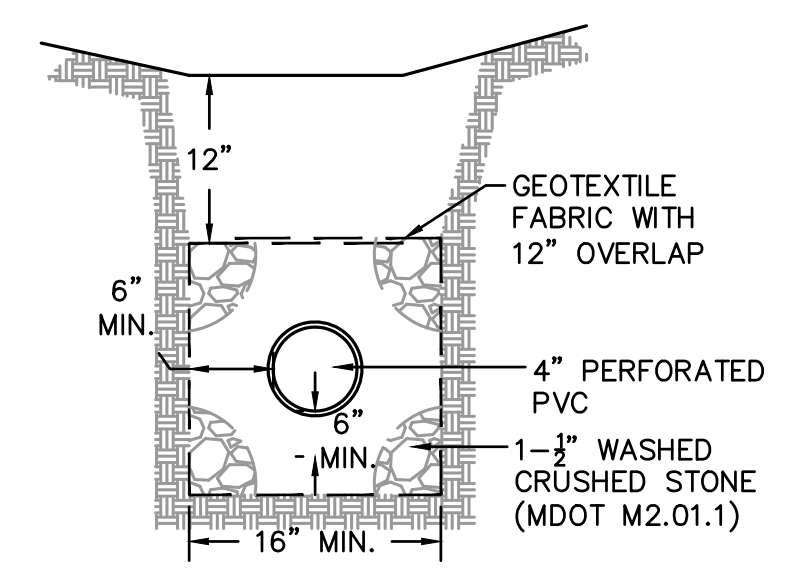

UNDERDRAIN DETAIL
NOT TO SCALE

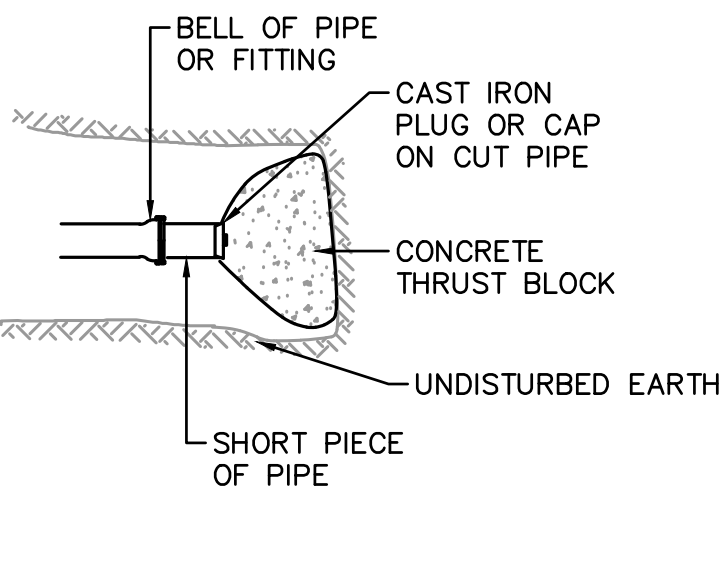

PLUG OR CAP DETAIL
NOT TO SCALE

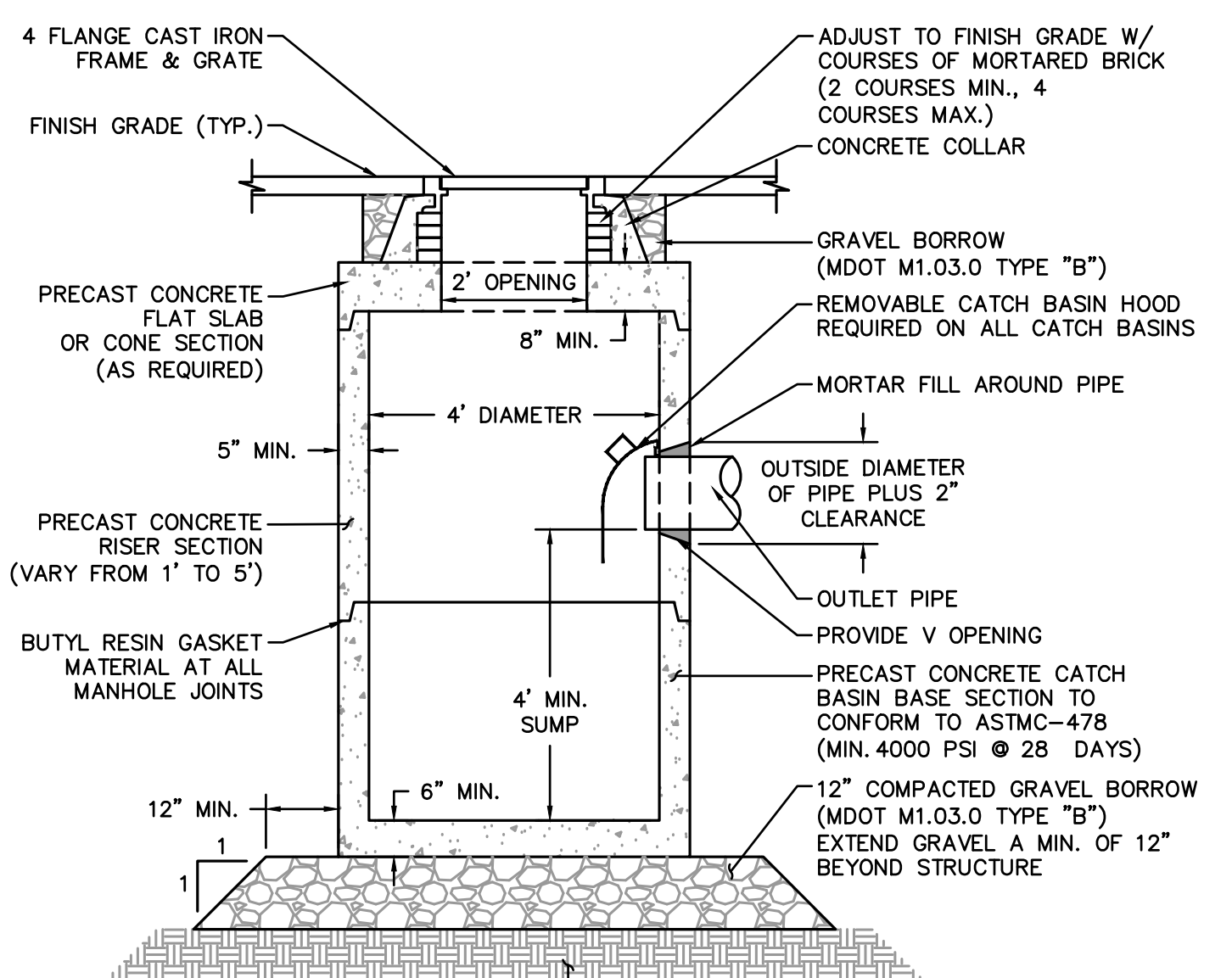

TYPICAL CATCH BASIN DETAIL
NOT TO SCALE

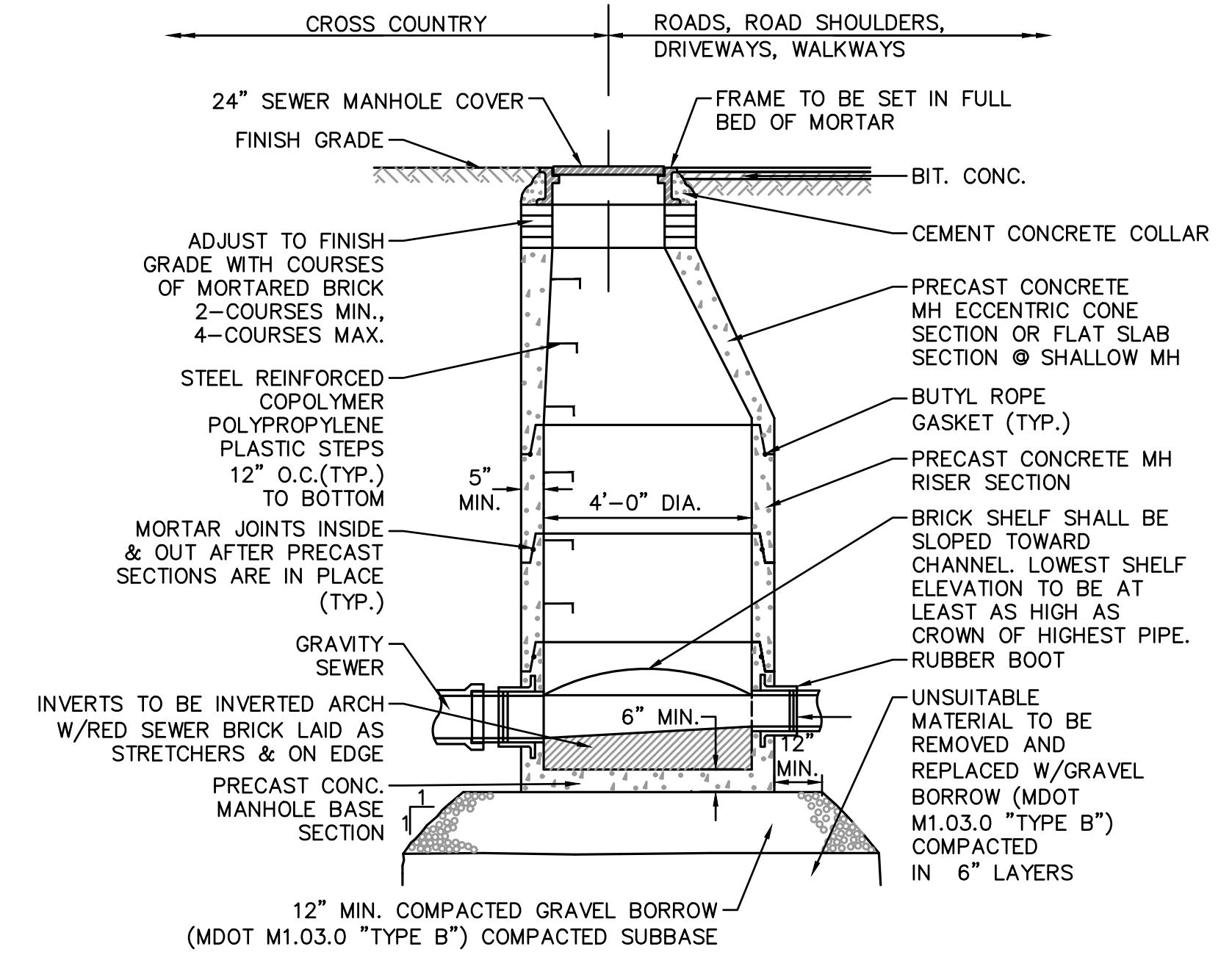

TYPICAL SEWER MANHOLE DETAIL
NOT TO SCALE

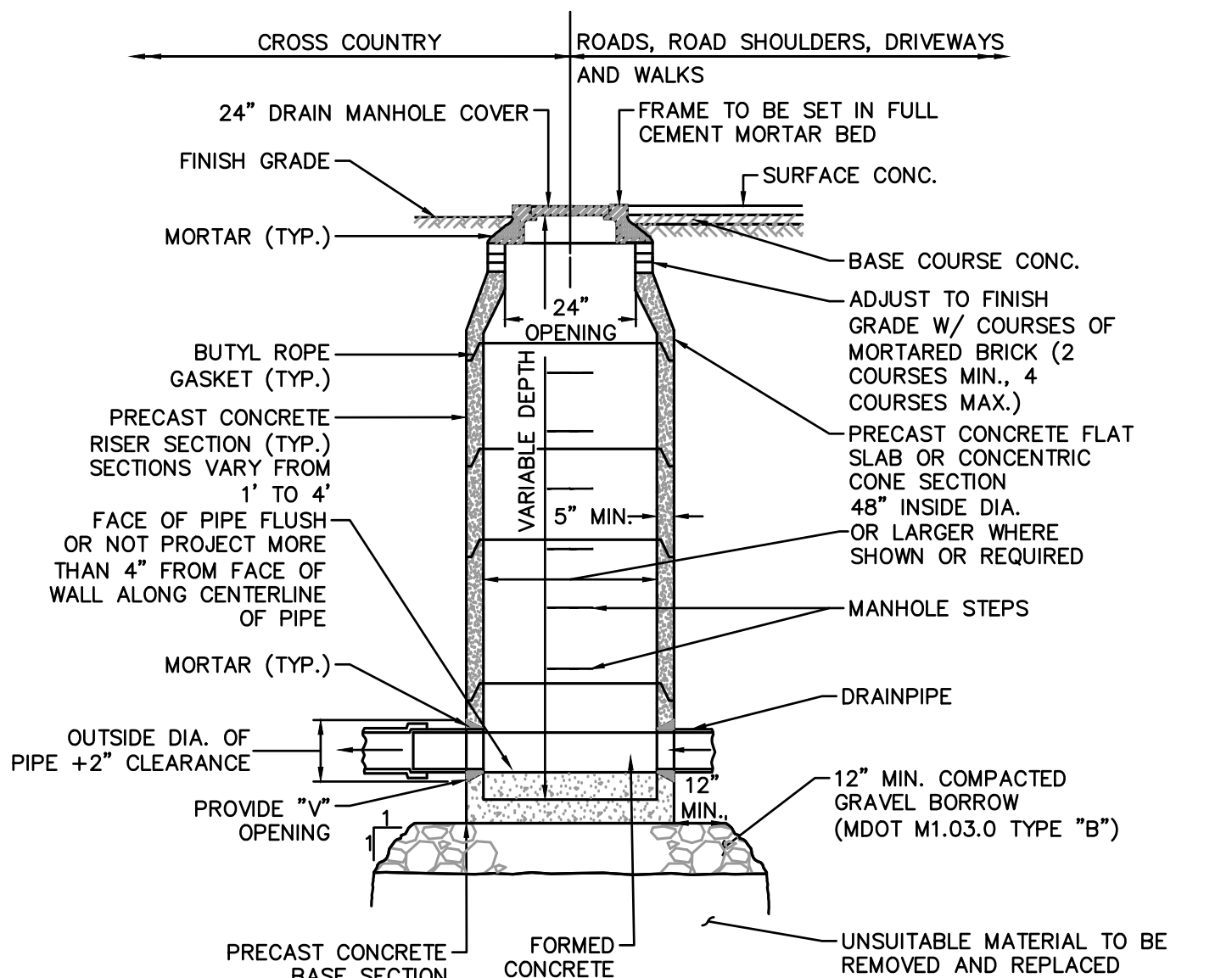

TYPICAL DRAIN MANHOLE DETAIL
NOT TO SCALE

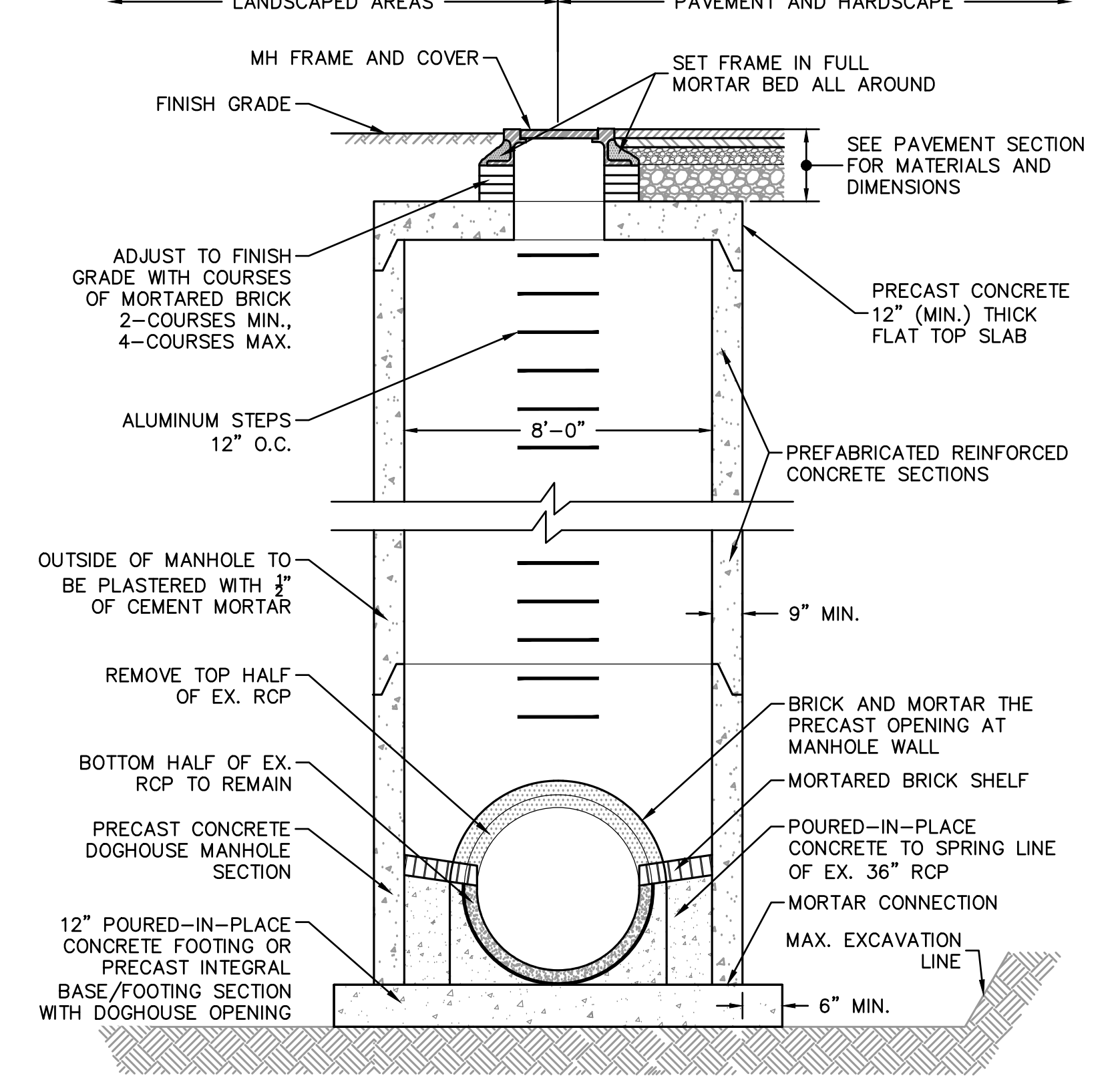

8' DOGHOUSE MANHOLE DETAIL
NOT TO SCALE

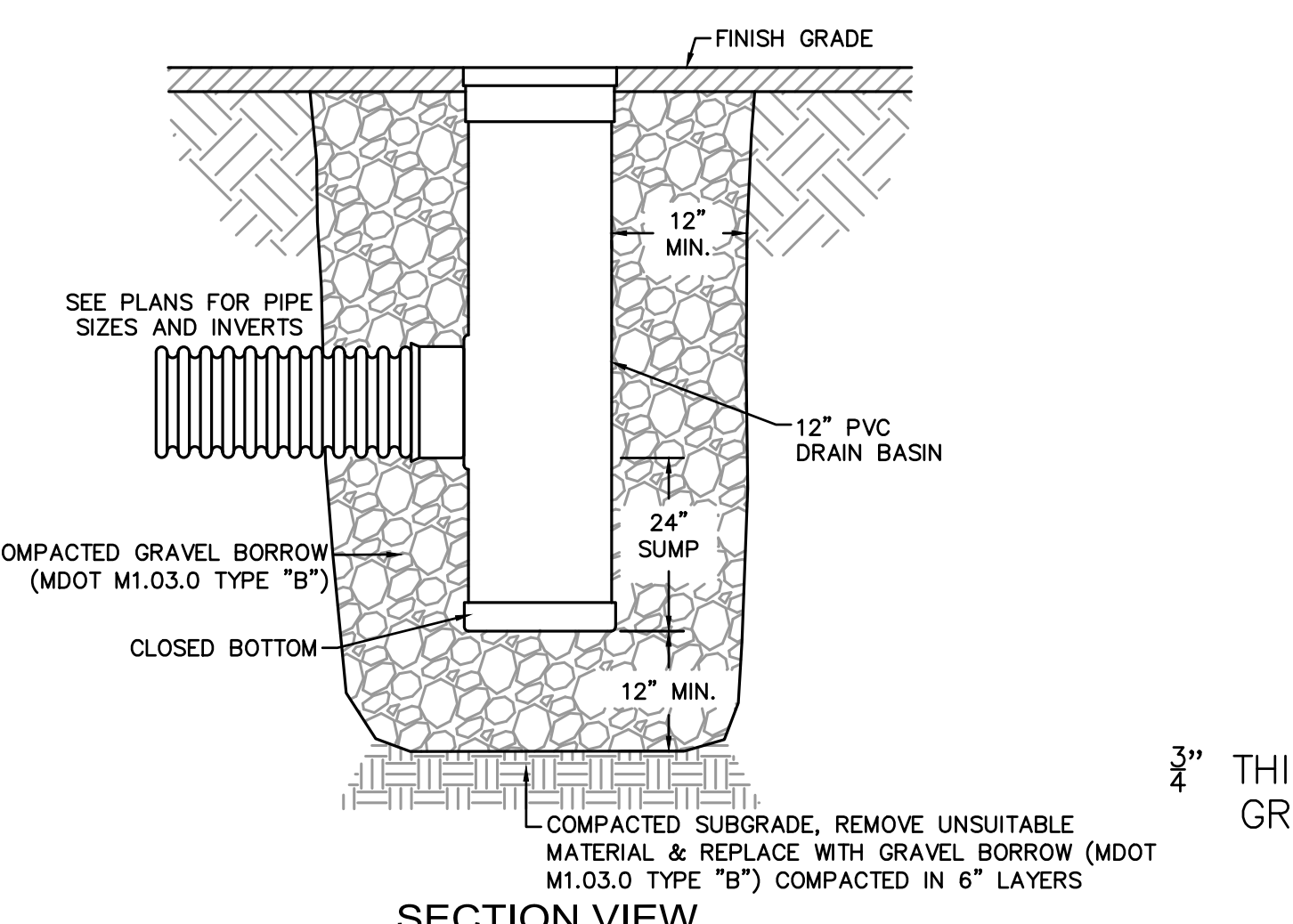

12\"/>

NOTES:
1. FRAME AND GRATE SHALL BE DUCTILE IRON CONFORMING TO ASTM A536 GRADE 70-50-05.
2. 12\"/>

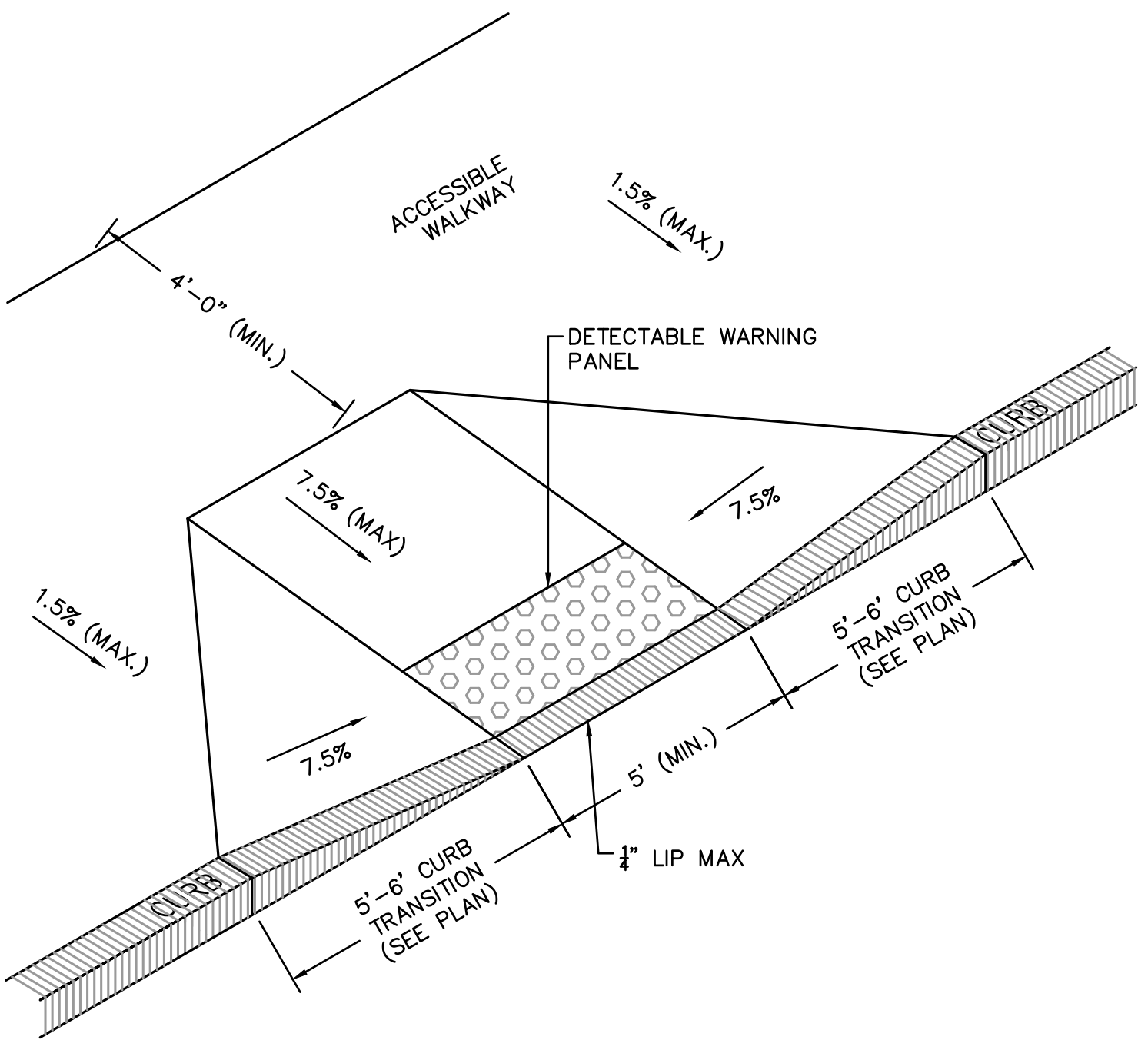

ACCESSIBLE RAMPS WITH GREATER THAN 12'-6\"/>

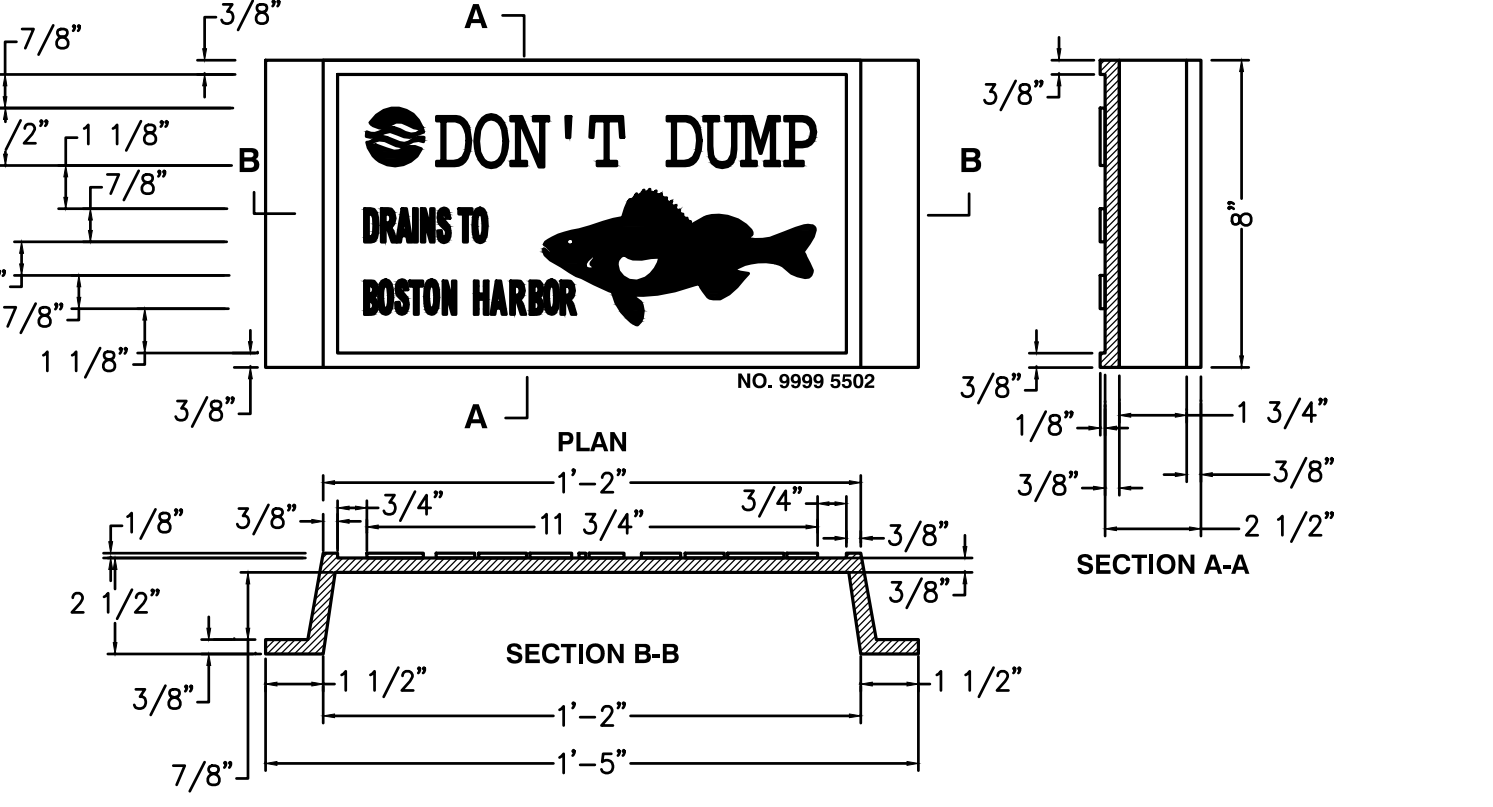

BWSC \"DON'T DUMP\" PLAQUE DETAIL
NOT TO SCALE

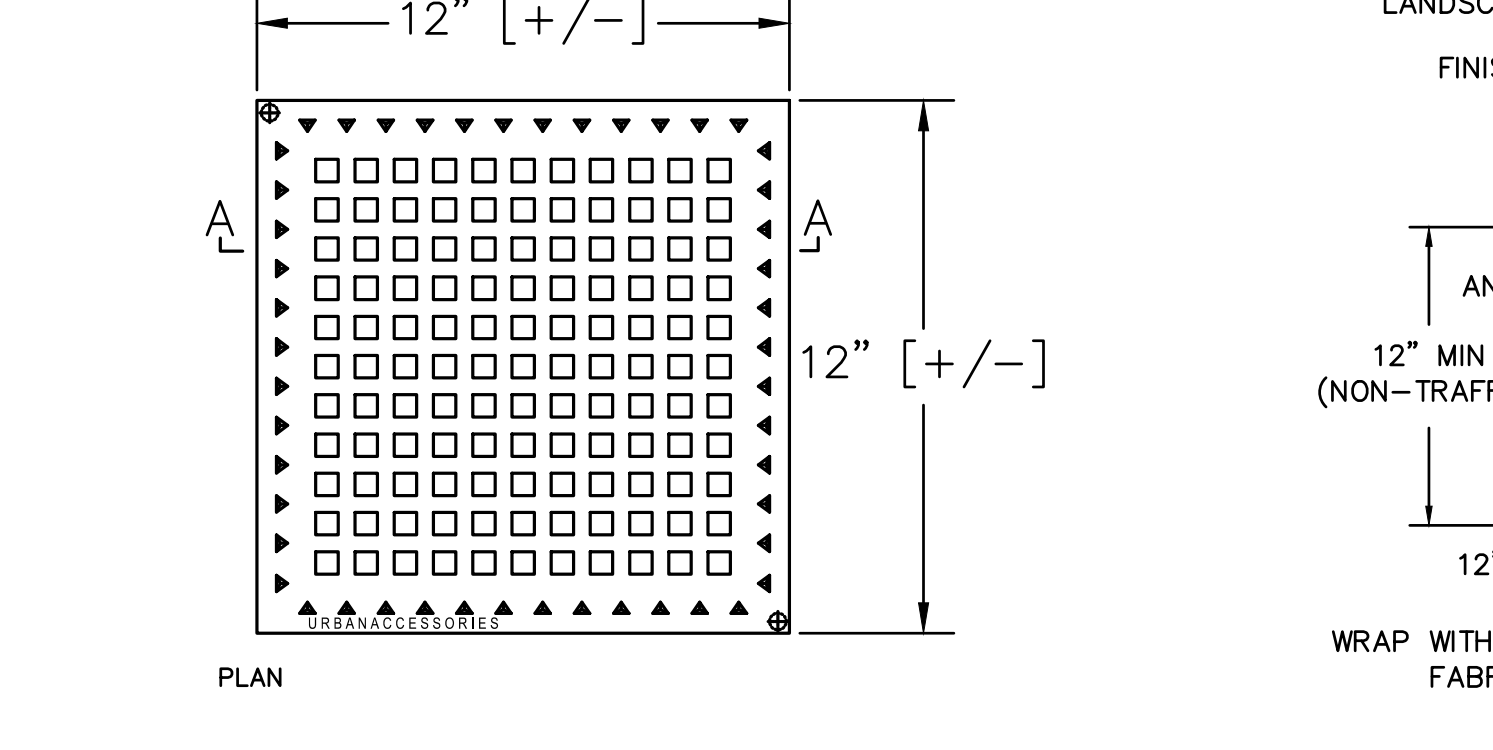

PEDESTRIAN GRATE (ADA COMPLIANT)
NOT TO SCALE

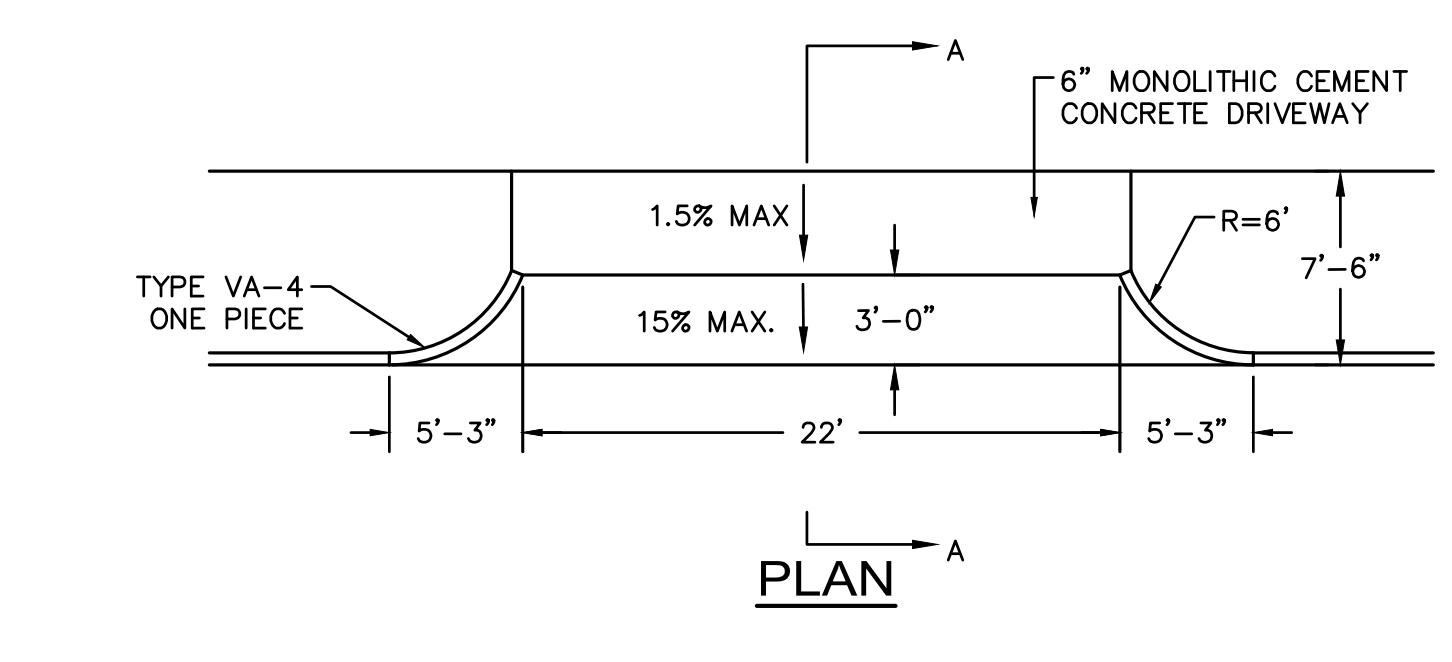

SECTION A-A CONCRETE DRIVEWAY
TYPICAL DRIVEWAY-BOSTON STANDARD DETAIL
NOT TO SCALE

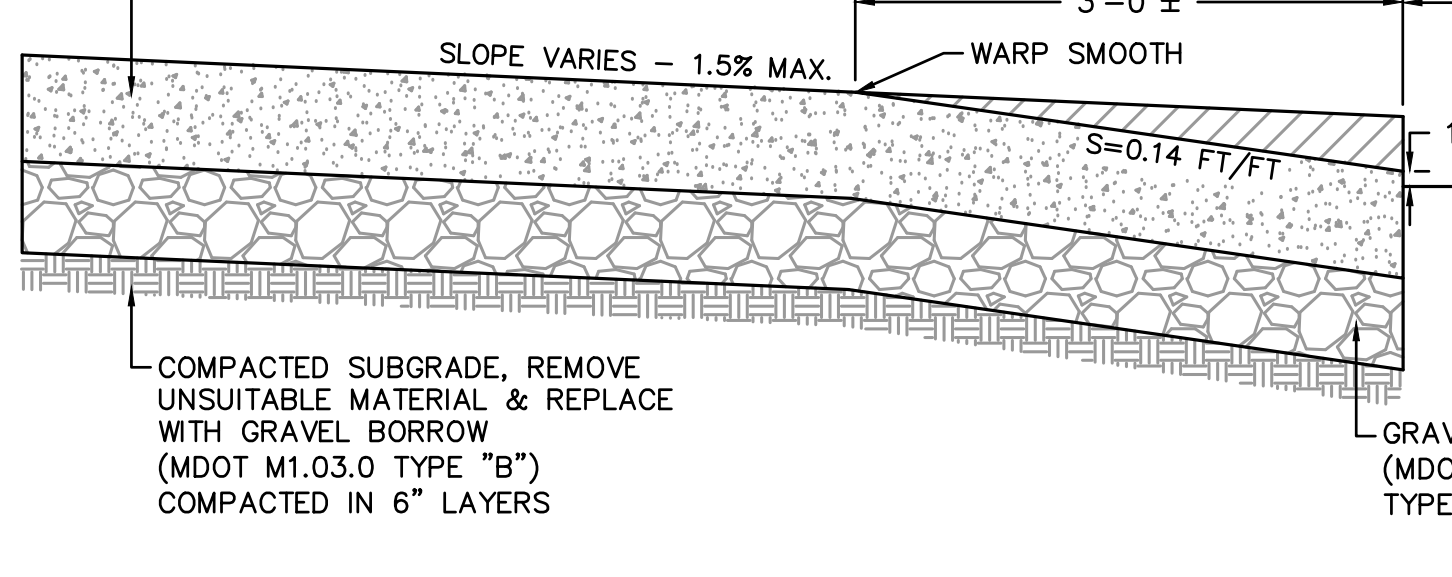

TYPICAL DRIVEWAY-BOSTON STANDARD DETAIL
NOT TO SCALE

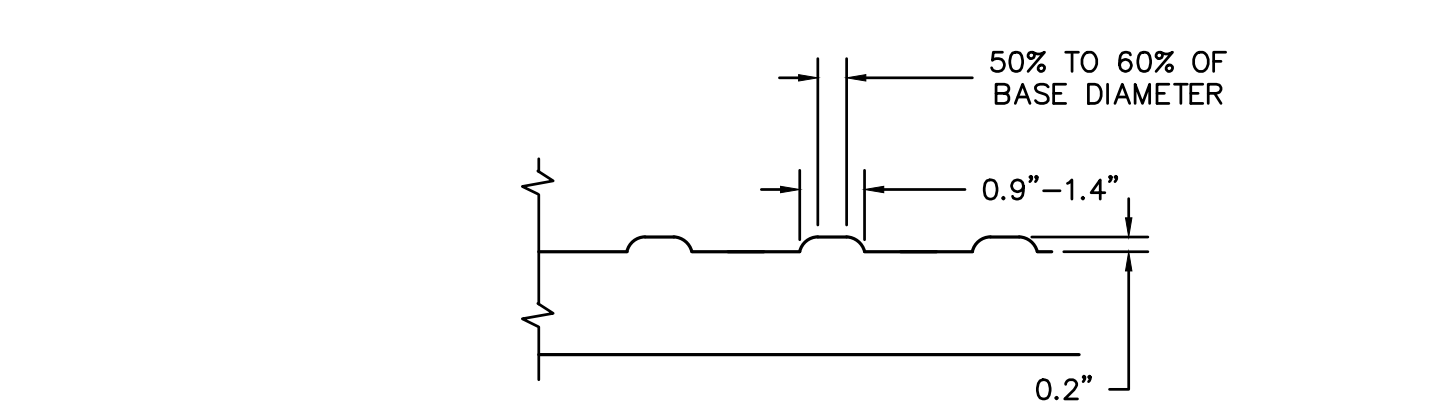

SECTION A-A

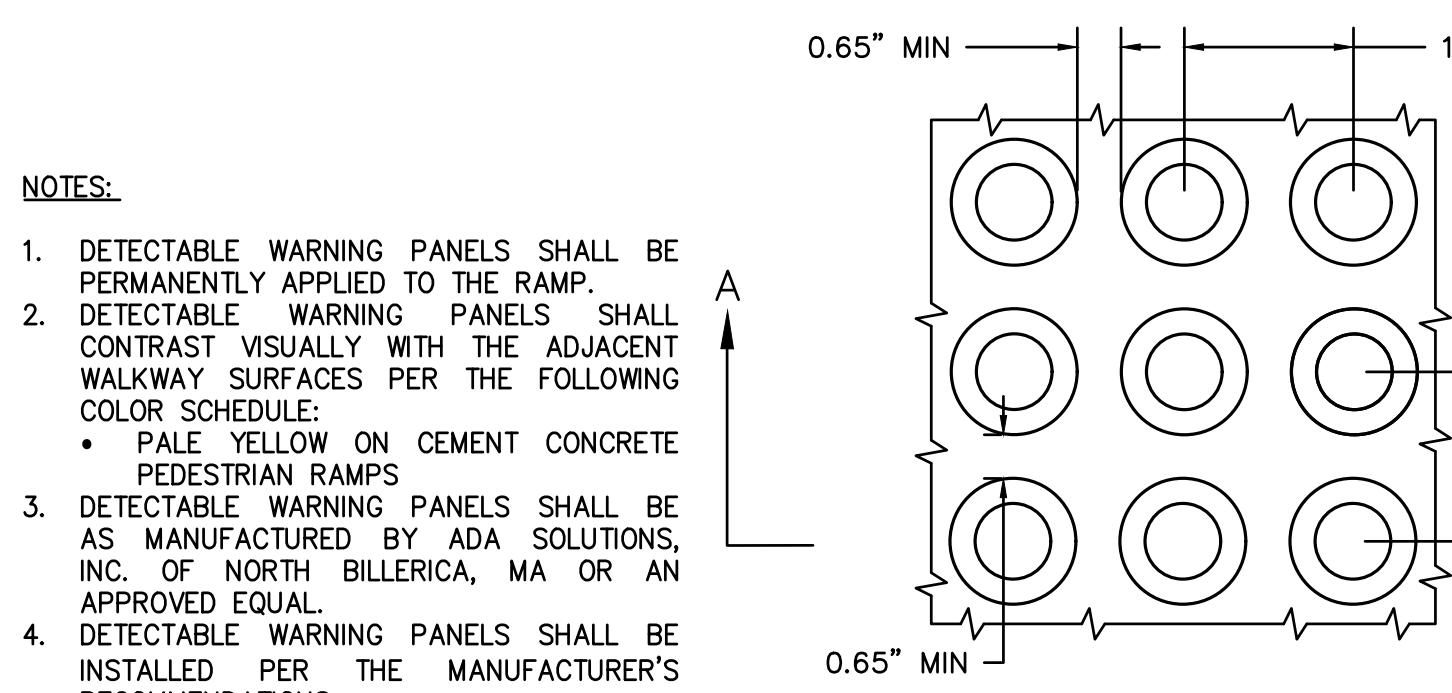

DETECTABLE WARNING PANEL

DETECTABLE WARNING PANEL FOR PEDESTRIAN RAMPS DETAIL
NOT TO SCALE

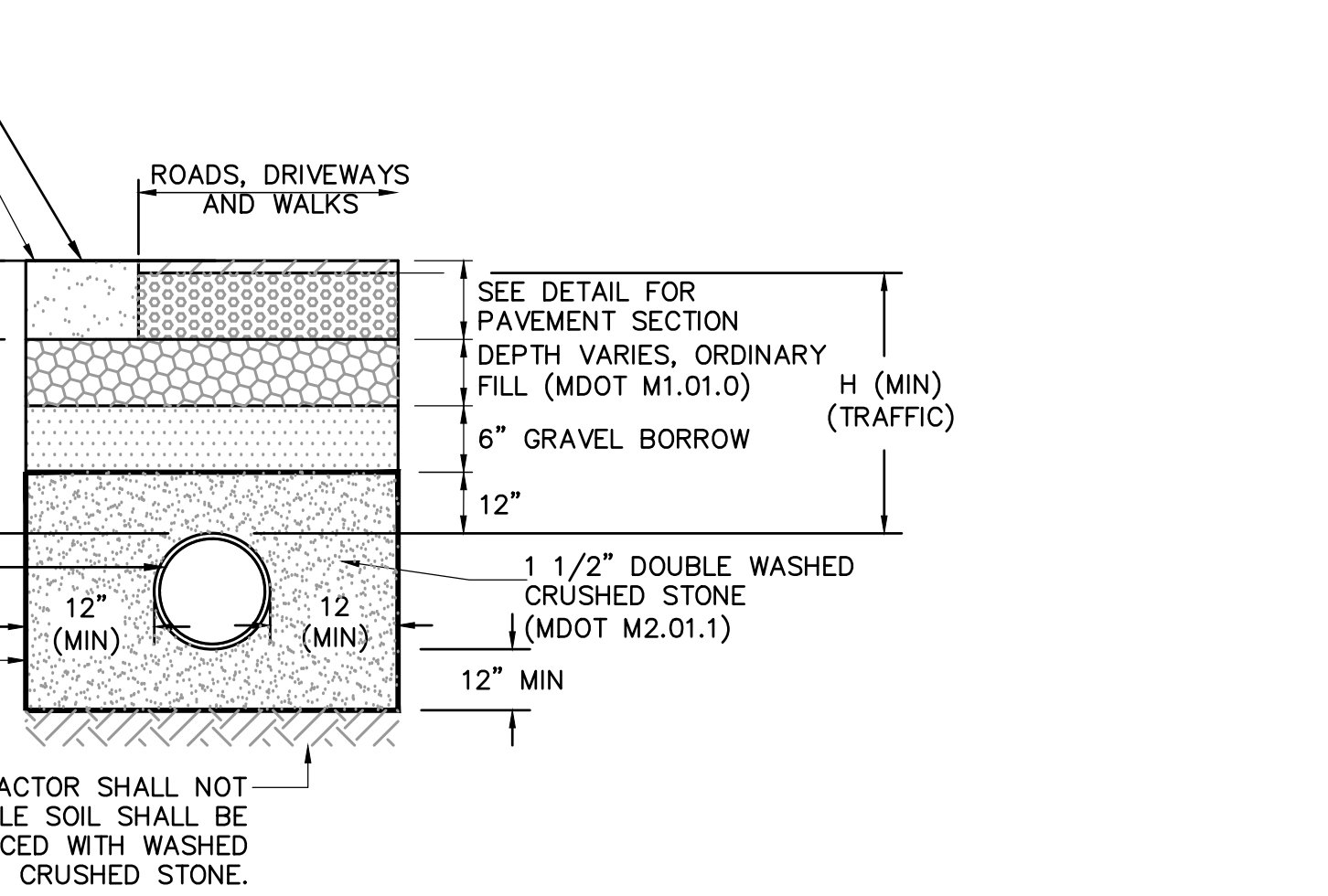

SUBSURFACE SYSTEM 1 INFILTRATION SYSTEM DETAIL
NOT TO SCALE



KEY PLAN

2 HARBOR

329 NORTHERN AVE
BOSTON, MA 02210

OWNER
BCP-CG HARBOR PROPERTY LLC
C/O BEACON CAPITAL PARTNERS, LLC
200 STATE STREET, FIFTH FLOOR
BOSTON, MA 02119

ARCHITECT
HANDEL ARCHITECTS, LLP
69 CANAL ST., 2ND FLOOR
BOSTON, MA 02114
T: 617.651.4790

CONSULTING ARCHITECT
STUDIO ENÉE
460 HILLSIDE AVE
NEEDHAM, MA 02494
T: 781.858.3011

CONSULTING ARCHITECT
TRIA
21 DRYDOCK AVE, SUITE 330W
BOSTON, MA 02114
T: 617.530.1620

CIVIL ENGINEER
NITSCH ENGINEERING, INC.
2 CENTER PLAZA #430
BOSTON, MA 02108
T: 617.338.0063

MEP ENGINEER & CODE CONSULTANT
COSENTINI ASSOCIATES
101 FEDERAL ST #600
BOSTON, MA 02110
T: 617.748.7800

STRUCTURAL ENGINEER
DESIMONE CONSULTING ENGINEERS
31 MILK ST., SUITE 1016
BOSTON, MA 02109
T: 617.836.4492

LANDSCAPE ARCHITECT
KLOPFER MARTIN DESIGN GROUP
69 CANAL ST., 2ND FLOOR
BOSTON, MA 02114
T: 617.227.2560

ENVELOPE CONSULTANT
CBI CONSULTING, LLC
250 DORCHESTER AVE
BOSTON, MA 02127
T: 617.268.8977

GEOTECHNICAL
HALEY & ALDRICH, INC.
465 MEDFORD ST., SUITE 2200
BOSTON, MA 02129
T: 617.886.7400

NOT FOR CONSTRUCTION

NO.	DATE	ISSUANCE
1	12/20/2019	CONCEPT PRICING
2	12/15/2020	50% SCHEMATIC DESIGN
3	2/18/2021	100% SCHEMATIC DESIGN
4	4/16/2021	EARLY SITE PACKAGE

PROJECT DATUM: PROJ. 0'-0" = +16'-6" BCB
SCALE: AS NOTED
PROJECT NO: 1550
SEAL & SIGNATURE

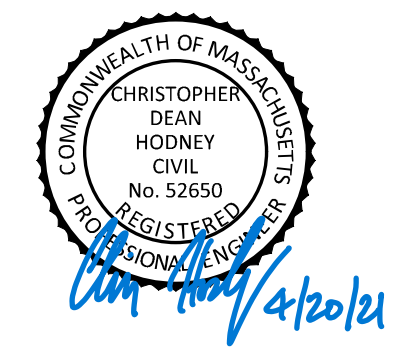

DRAWING TITLE:

DETAILS I

DRAWING NO:

C-500

OWNER
 BCP-CG HARBOR PROPERTY LLC
 C/O BEACON CAPITAL PARTNERS, LLC
 200 STATE STREET, FIFTH FLOOR
 BOSTON, MA 02109

ARCHITECT
 HANDEL ARCHITECTS, LLP
 89 CANAL ST, 2ND FLOOR
 BOSTON, MA 02114
 T: 617.651.4790

CONSULTING ARCHITECT
 STUDIO ENÉE
 460 HILLSIDE AVE
 NEEDHAM, MA 02494
 T: 781.858.3011

CONSULTING ARCHITECT
 TRIA
 21 DRYDOCK AVE, SUITE 330W
 BOSTON, MA 02210
 T: 617.530.1620

CIVIL ENGINEER
 NITSCH ENGINEERING, INC.
 2 CENTER PLAZA #430
 BOSTON, MA 02108
 T: 617.338.0063

MEP ENGINEER & CODE CONSULTANT
 COSENTINI ASSOCIATES
 101 FEDERAL ST #600
 BOSTON, MA 02110
 T: 617.748.7800

STRUCTURAL ENGINEER
 DESIMONE CONSULTING ENGINEERS
 31 MILK ST, SUITE 1016
 BOSTON, MA 02109
 T: 617.836.4492

LANDSCAPE ARCHITECT
 KLOPFER MARTIN DESIGN GROUP
 69 CANAL ST, 2ND FLOOR
 BOSTON, MA 02114
 T: 617.227.2560

ENVELOPE CONSULTANT
 CBI CONSULTING, LLC
 250 DORCHESTER AVE
 BOSTON, MA 02127
 T: 617.268.8977

GEOTECHNICAL
 HALEY & ALDRICH, INC.
 485 MEDFORD ST, SUITE 2200
 BOSTON, MA 02129
 T: 617.886.7400

NOT FOR CONSTRUCTION

NO.	DATE	ISSUANCE
1	12/20/2019	CONCEPT PRICING
2	12/15/2020	50% SCHEMATIC DESIGN
3	2/18/2021	100% SCHEMATIC DESIGN
4	4/16/2021	EARLY SITE PACKAGE

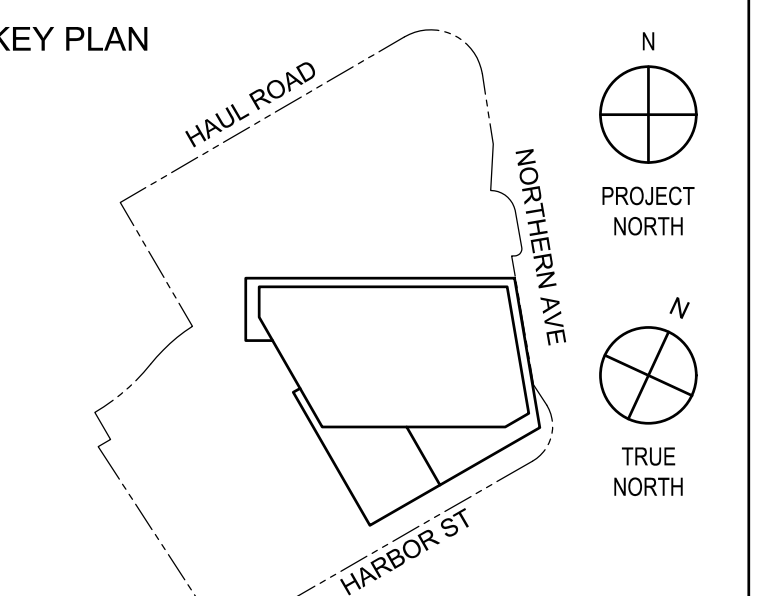

PROJECT DATUM: PROJ. 0'-0" = +16'-6" BCB
 SCALE: AS NOTED
 PROJECT NO: 1550
 SEAL & SIGNATURE

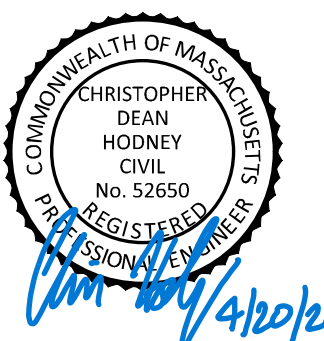

DRAWING TITLE:

DETAILS II

DRAWING NO:

C-501

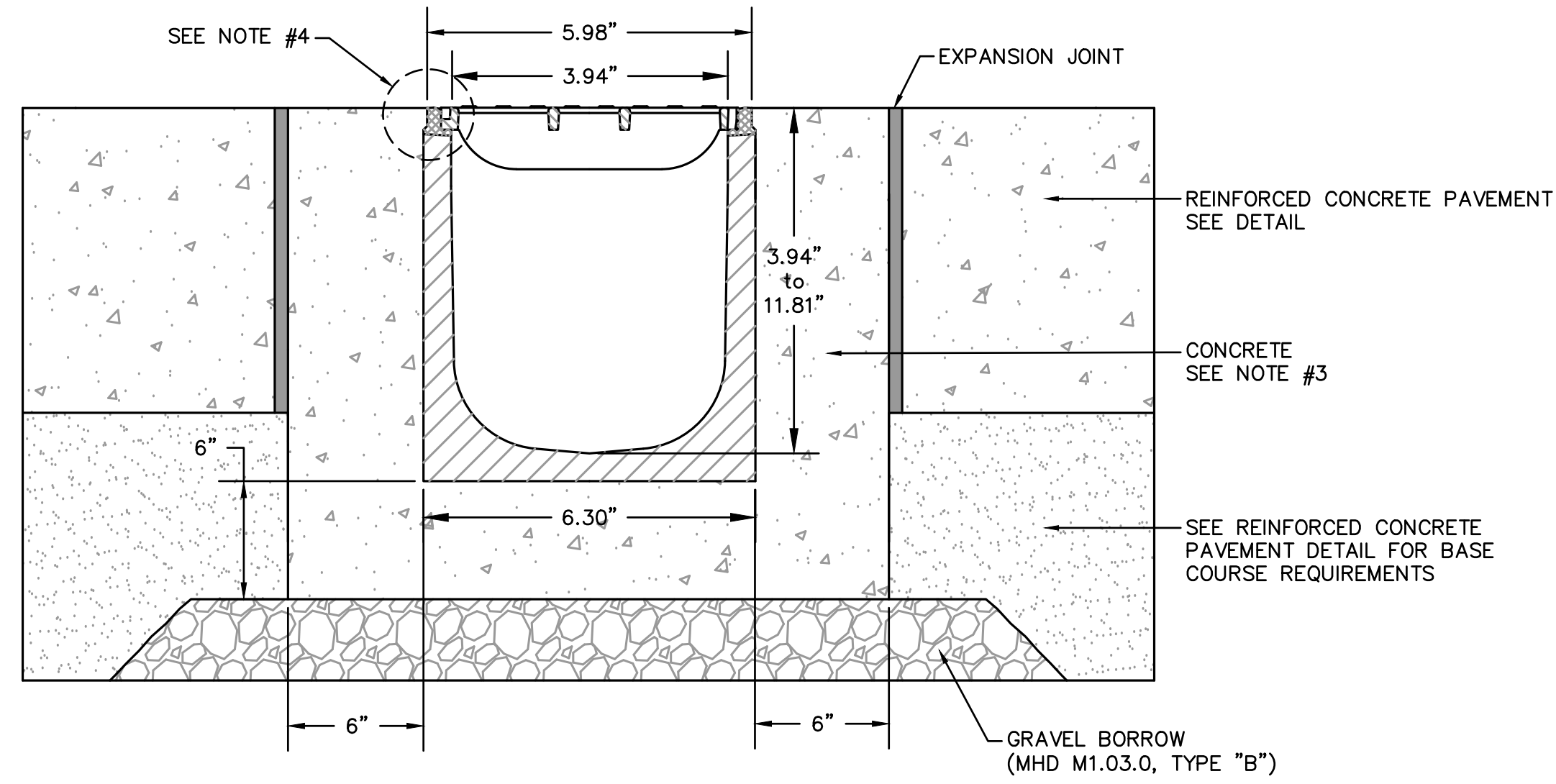

- NOTES:
- TRENCH DRAIN SHALL BE A POLYMER CONCRETE CHANNEL SYSTEM WITH A DUCTILE IRON RAIL AND GRATE.
 - TRENCH DRAIN SYSTEM AND GRATES SHALL BE H-20 LOADING.
 - CONCRETE CRADLE FOR TRENCH DRAIN SHALL BE MINIMUM 4,000 PSI. CONCRETE SHALL BE VIBRATED TO ELIMINATE AIR POCKETS.
 - THE FINISHED LEVEL OF THE SURROUNDING CONCRETE SHALL BE SET 1/8" ABOVE THE TOP OF THE CHANNEL EDGE.
 - TRENCH DRAIN GRATE SHALL BE ADA COMPLIANT.
 - TRENCH DRAIN SYSTEM SHALL BE INSTALLED PER MANUFACTURER'S RECOMMENDATIONS.
 - ALL TRENCH DRAINS SHALL BE PROVIDED WITH AN INLINE CATCH BASIN AT THE LOW POINT OF THE SYSTEM. WIDTH OF INLINE CATCH BASIN TO MATCH WIDTH OF TRENCH DRAIN.

4" TRENCH DRAIN IN CONCRETE PAVEMENT DETAIL
 NOT TO SCALE

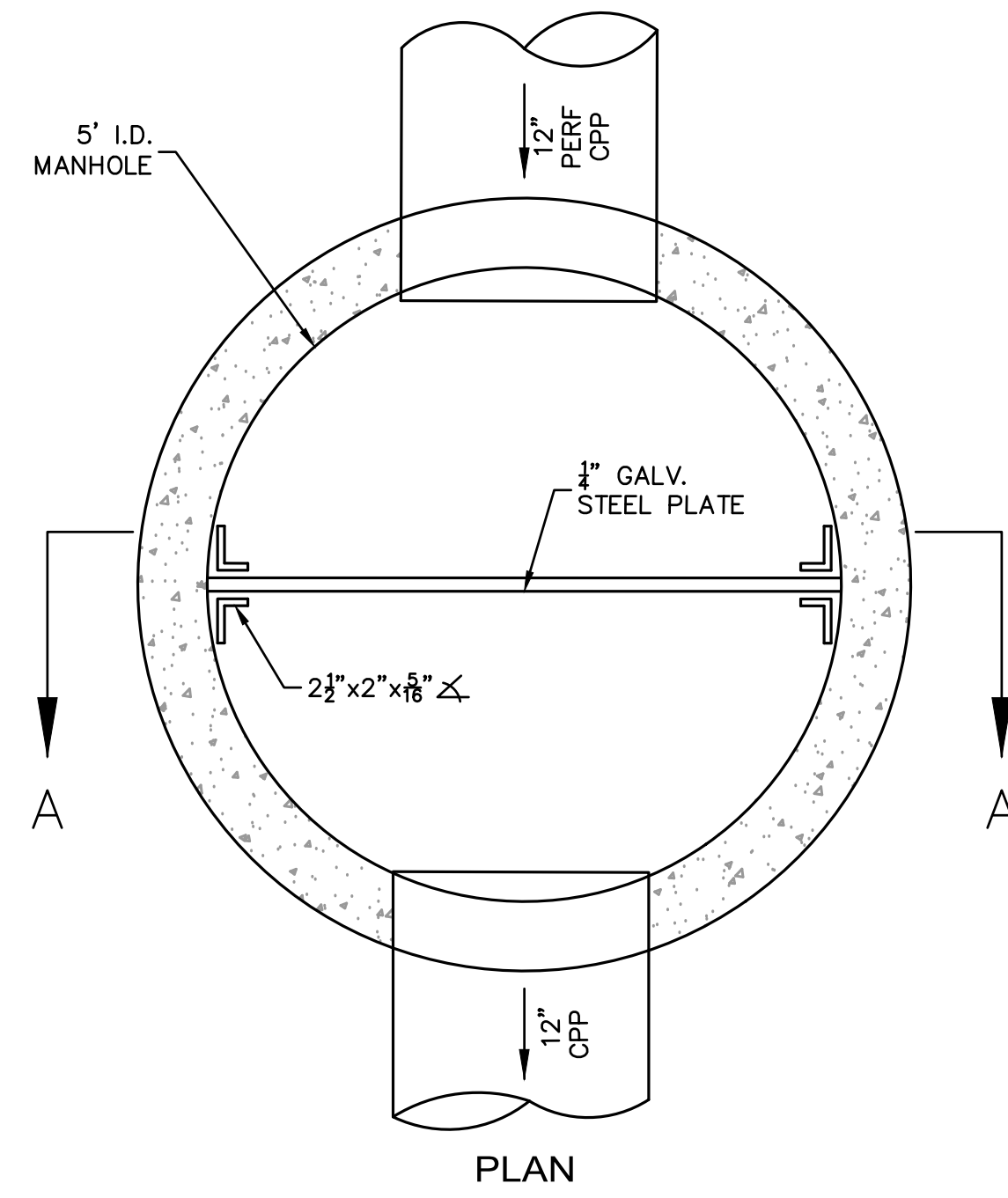

OUTLET CONTROL STRUCTURE (OCS601)
 NOT TO SCALE

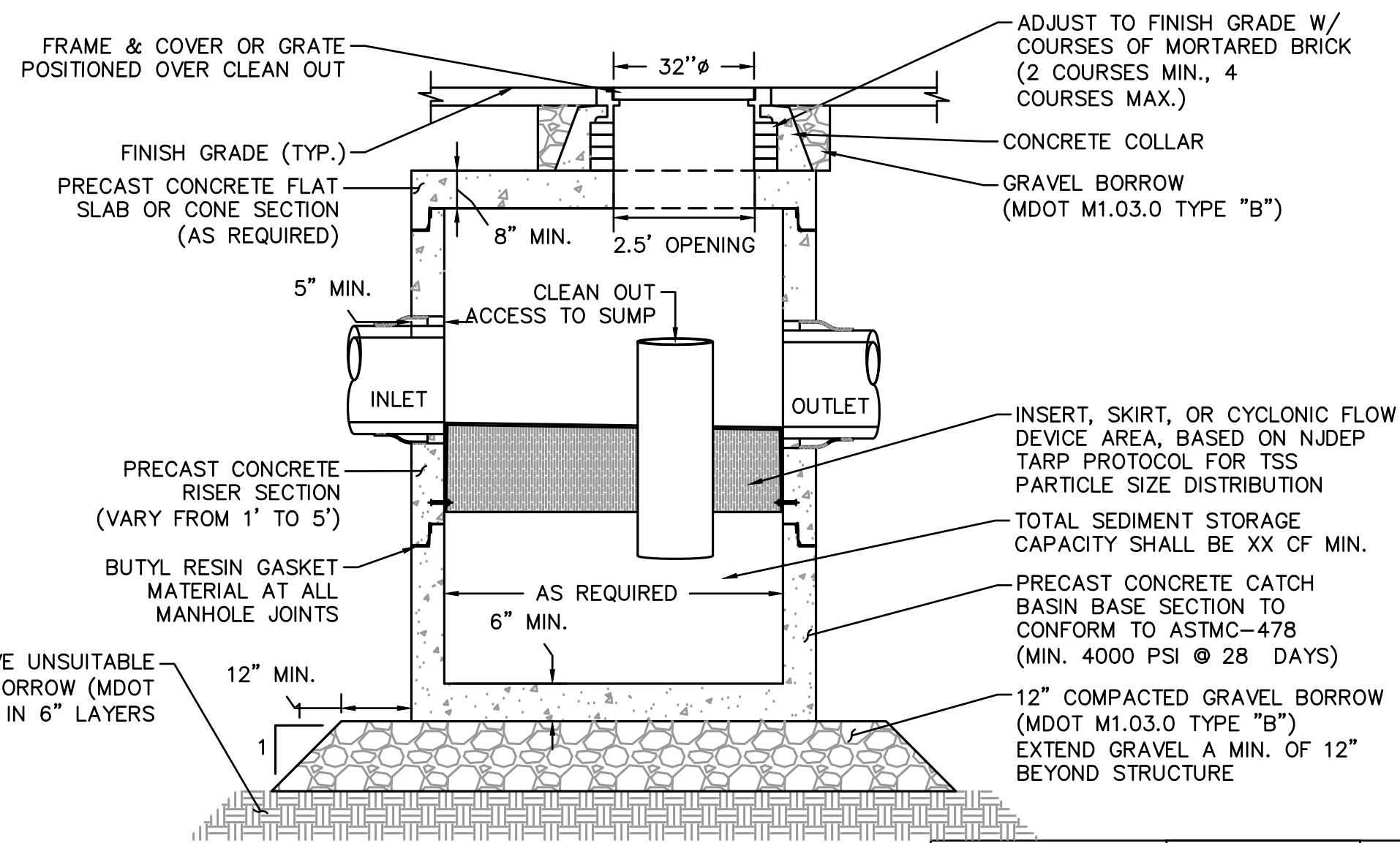
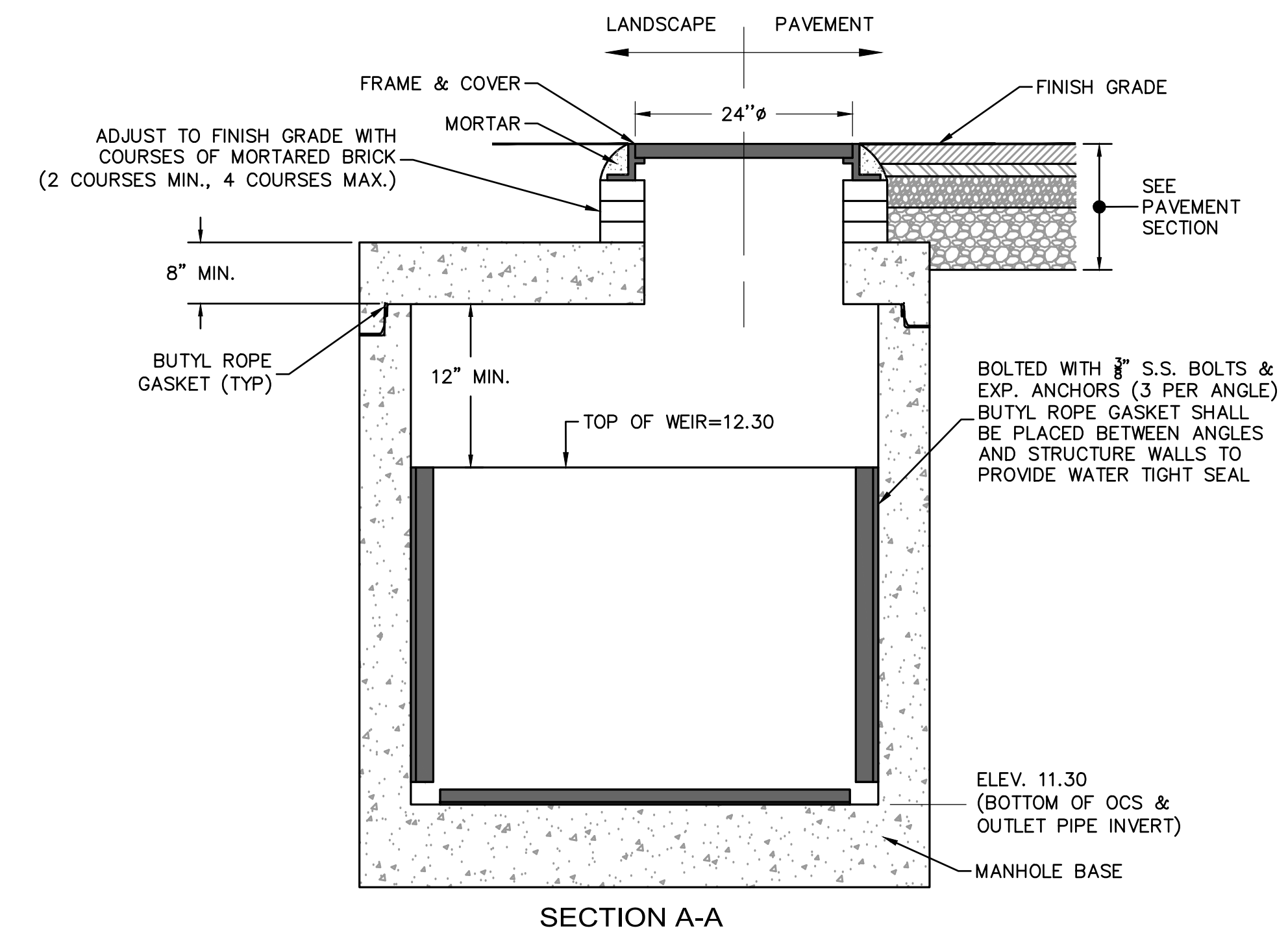

- NOTE:
- THE USE OF FLEXIBLE CONNECTIONS IS RECOMMENDED AT THE INLET AND OUTLET WHERE APPLICABLE.
 - THE COVER SHOULD BE POSITIONED OVER THE OUTLET DROP PIPE AND THE OIL CLEANOUT PIPE.
 - STRUCTURE DESIGNED FOR H2O LOADING

STRUCTURE NAME	MINIMUM WQF	PEAK FLOW RATE*	MINIMUM SEDIMENT STORAGE CAPACITY
WQ500	0.70 CFS	6.57 CFS	15 CF
WQ501	1.91 CFS	4.11 CFS	33 CF

* PEAK FLOW RATE BASED ON RATIONAL ANALYSIS FOR A 25-YEAR STORM EVENT. STRUCTURE SHALL BE ABLE TO PASS PEAK FLOW RATE WITHOUT CAUSING A BACKWATER CONDITION.

WATER QUALITY STRUCTURE DETAIL
 NOT TO SCALE

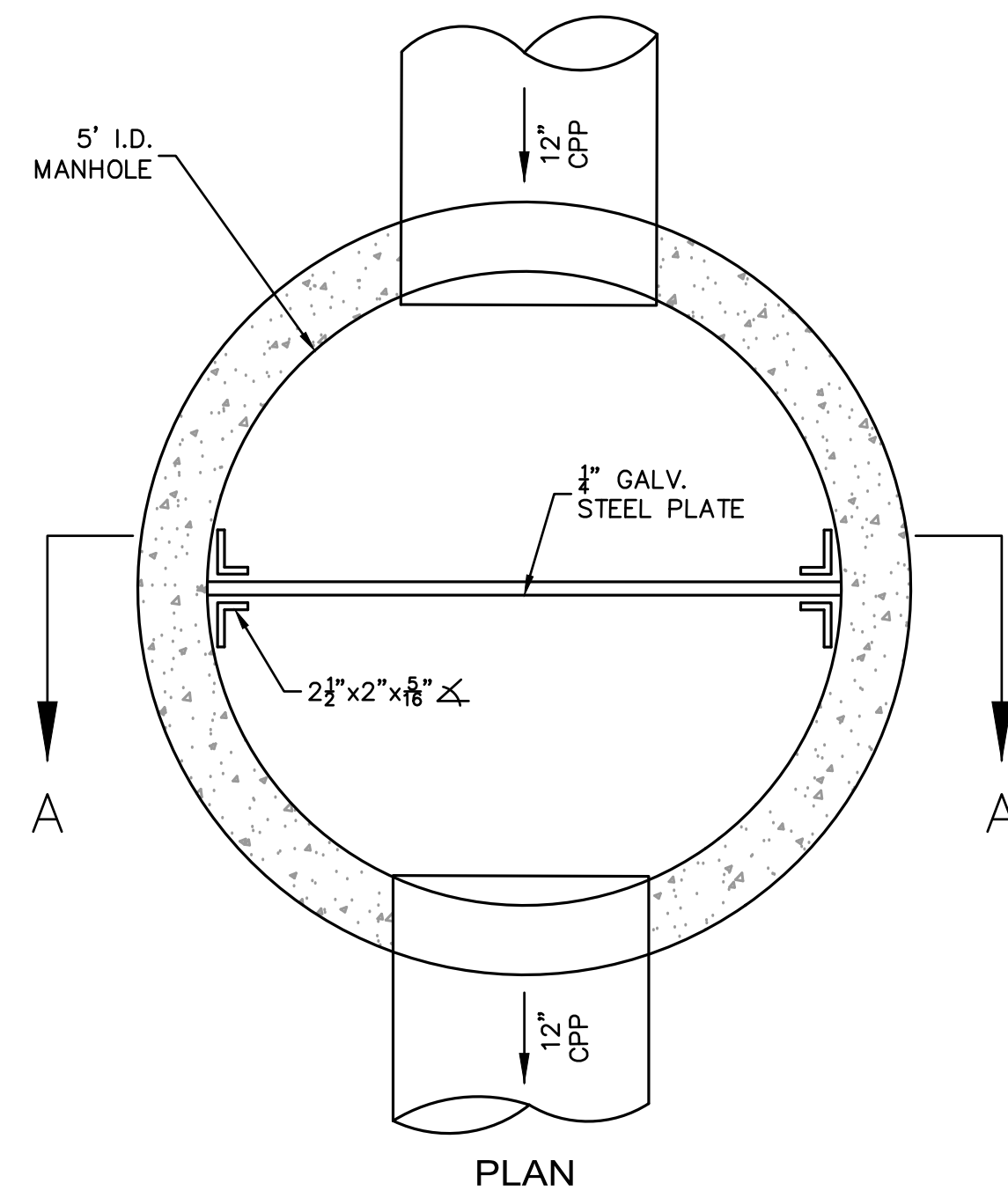

OUTLET CONTROL STRUCTURE (OCS600)
 NOT TO SCALE

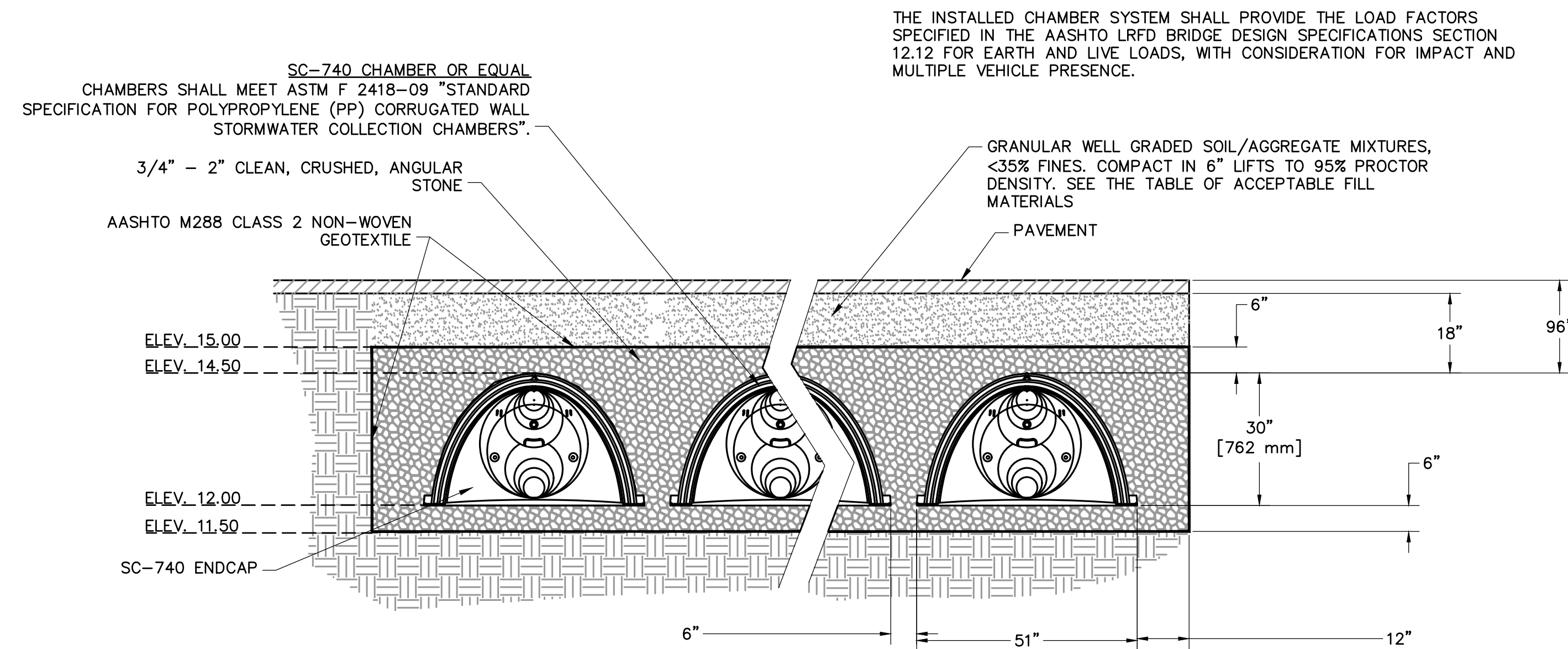
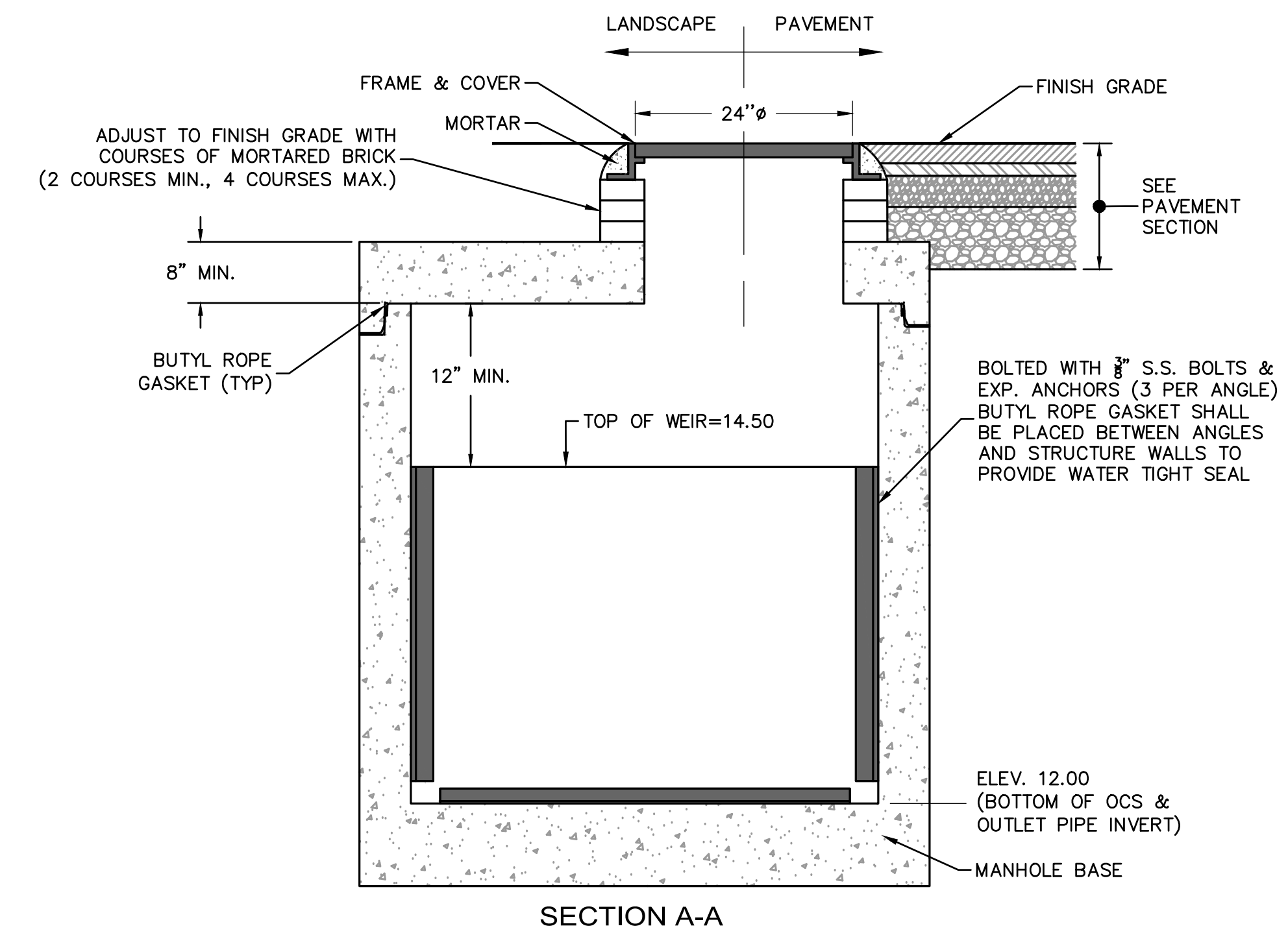

SUBSURFACE SYSTEM 2A AND 2B INFILTRATION SYSTEM DETAIL
 NOT TO SCALE

2 HARBOR

329 NORTHERN AVE
BOSTON, MA 02210

OWNER
BCP-CG HARBOR PROPERTY LLC
C/O BEACON CAPITAL PARTNERS, LLC
200 STATE STREET, FIFTH FLOOR
BOSTON, MA 02109

ARCHITECT

HANDEL ARCHITECTS, LLP
69 CANAL ST., 2ND FLOOR
BOSTON, MA 02114
T: 617.651.4790

CONSULTING ARCHITECT

STUDIO ENÉE
460 HILLSIDE AVE
NEEDHAM, MA 02494
T: 781.858.3011

CONSULTING ARCHITECT

TRIA
21 DRYDOCK AVE, SUITE 330W
BOSTON, MA 02210
T: 617.530.1620

CIVIL ENGINEER

NITSCH ENGINEERING, INC.
2 CENTER PLAZA #430
BOSTON, MA 02108
T: 617.338.0063

MEP ENGINEER & CODE CONSULTANT

COSENTINI ASSOCIATES
101 FEDERAL ST #600
BOSTON, MA 02110
T: 617.748.7800

STRUCTURAL ENGINEER

DESIMONE CONSULTING ENGINEERS
31 MILK ST., SUITE 1016
BOSTON, MA 02109
T: 617.836.4492

LANDSCAPE ARCHITECT

KLOPFER MARTIN DESIGN GROUP
69 CANAL ST., 2ND FLOOR
BOSTON, MA 02114
T: 617.227.2560

ENVELOPE CONSULTANT

CBI CONSULTING, LLC
250 DORCHESTER AVE
BOSTON, MA 02127
T: 617.268.8977

GEOTECHNICAL

HALEY & ALDRICH, INC.
485 MEDFORD ST., SUITE 2200
BOSTON, MA 02129
T: 617.886.7400

NOT FOR CONSTRUCTION

NO.	DATE	ISSUANCE
1	12/20/2019	CONCEPT PRICING
2	12/15/2020	50% SCHEMATIC DESIGN
3	2/18/2021	100% SCHEMATIC DESIGN
4	4/16/2021	EARLY SITE PACKAGE

KEY PLAN

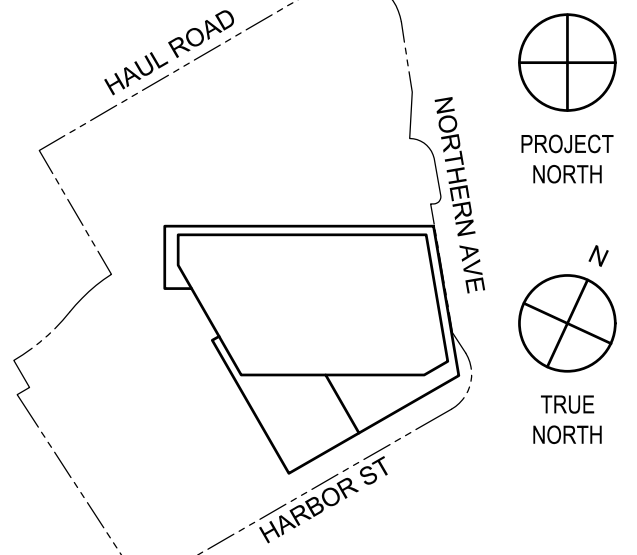

PROJECT DATUM: PROJ. 0'-0" = +16'-6" BCB
SCALE: AS NOTED
PROJECT NO.: 1550
SEAL & SIGNATURE



DRAWING TITLE:

DETAILS III

DRAWING NO.:

C-502

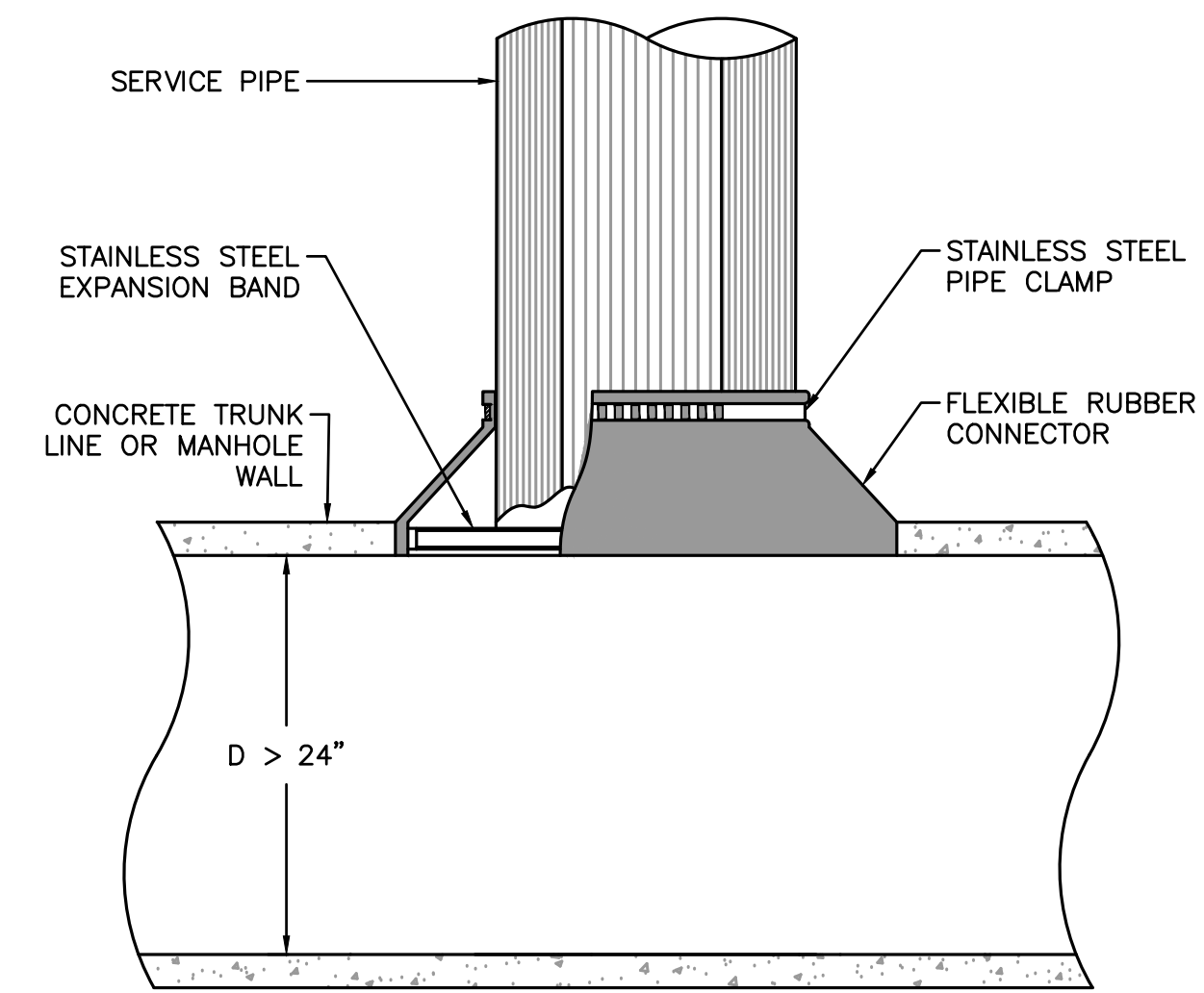

NOTES:

1. OPENING IN CONCRETE WALL SHALL BE CORED USING HIGH SPEED DIAMOND DRILL.
2. ALL METAL FIXTURES SHALL BE OF STAINLESS STEEL.
3. SERVICE LINE SHALL BE FLUSH WITH THE INSIDE OF THE CONCRETE PIPE OR WALL.
4. IF TRUNK LINE DIAMETER IS LESS THAN 24" THEN A SADDLE TYPE CONNECTION WILL BE USED.

TYPICAL FIELD CONNECTION TO LARGE CONCRETE PIPE OR CONCRETE MANHOLE DETAIL
NOT TO SCALE

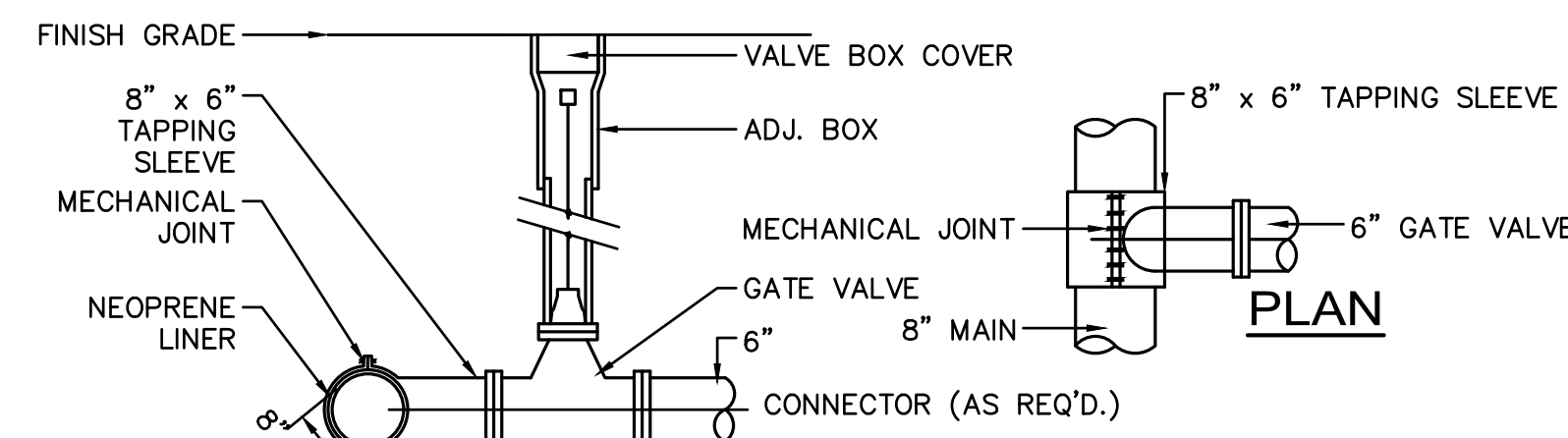

SECTION

TAPPING SLEEVE, VALVE & BOX DETAIL
NOT TO SCALE

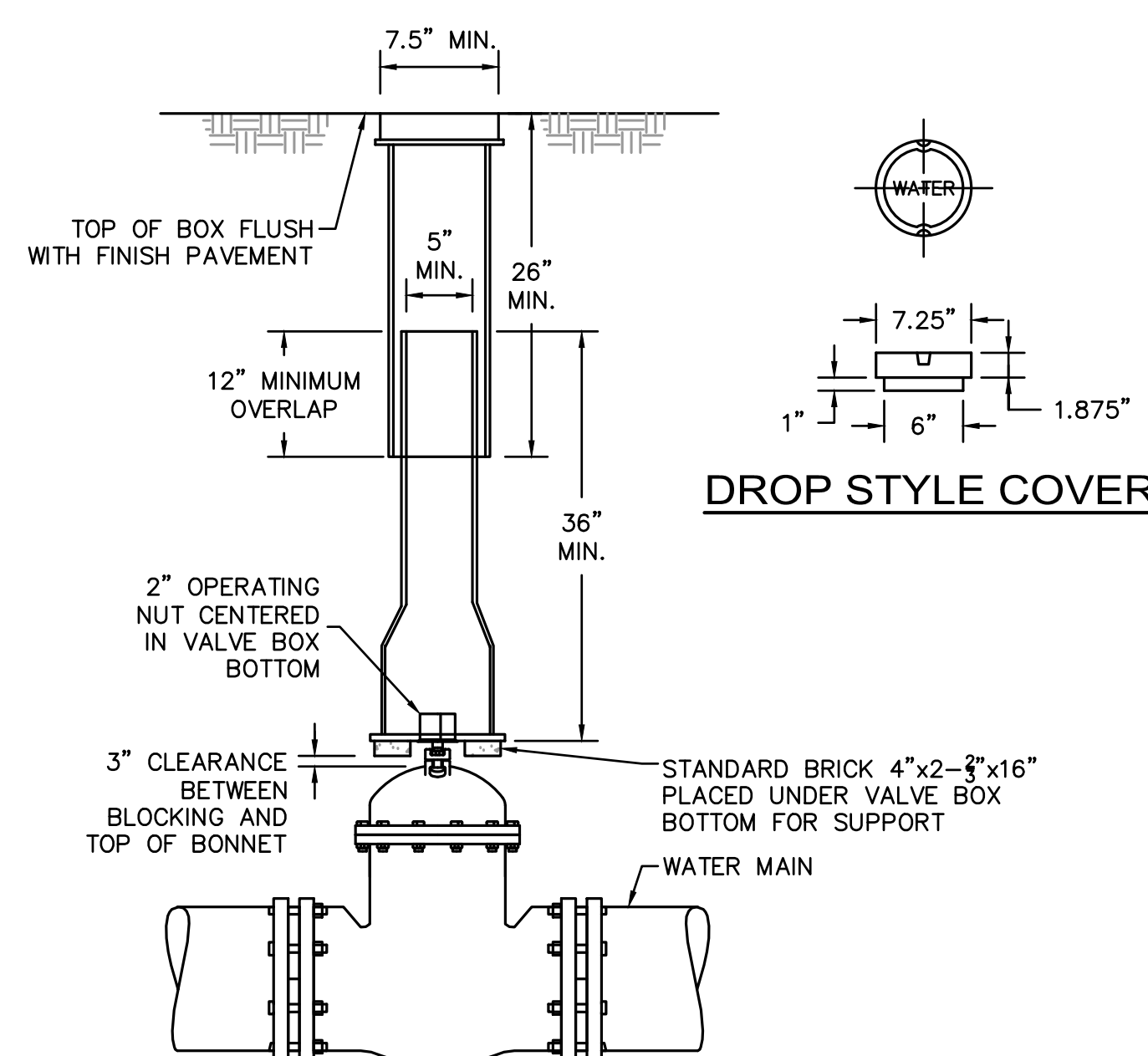

BOTTOM DETAIL

NOTES:

1. ALL WATER MAINS SHOULD HAVE A MINIMUM DEPTH OF 5' FROM TOP OF PIPE TO FINISH GRADE.
2. COVER MUST BE MARKED "WATER".

GATE VALVE BOX DETAIL
NOT TO SCALE

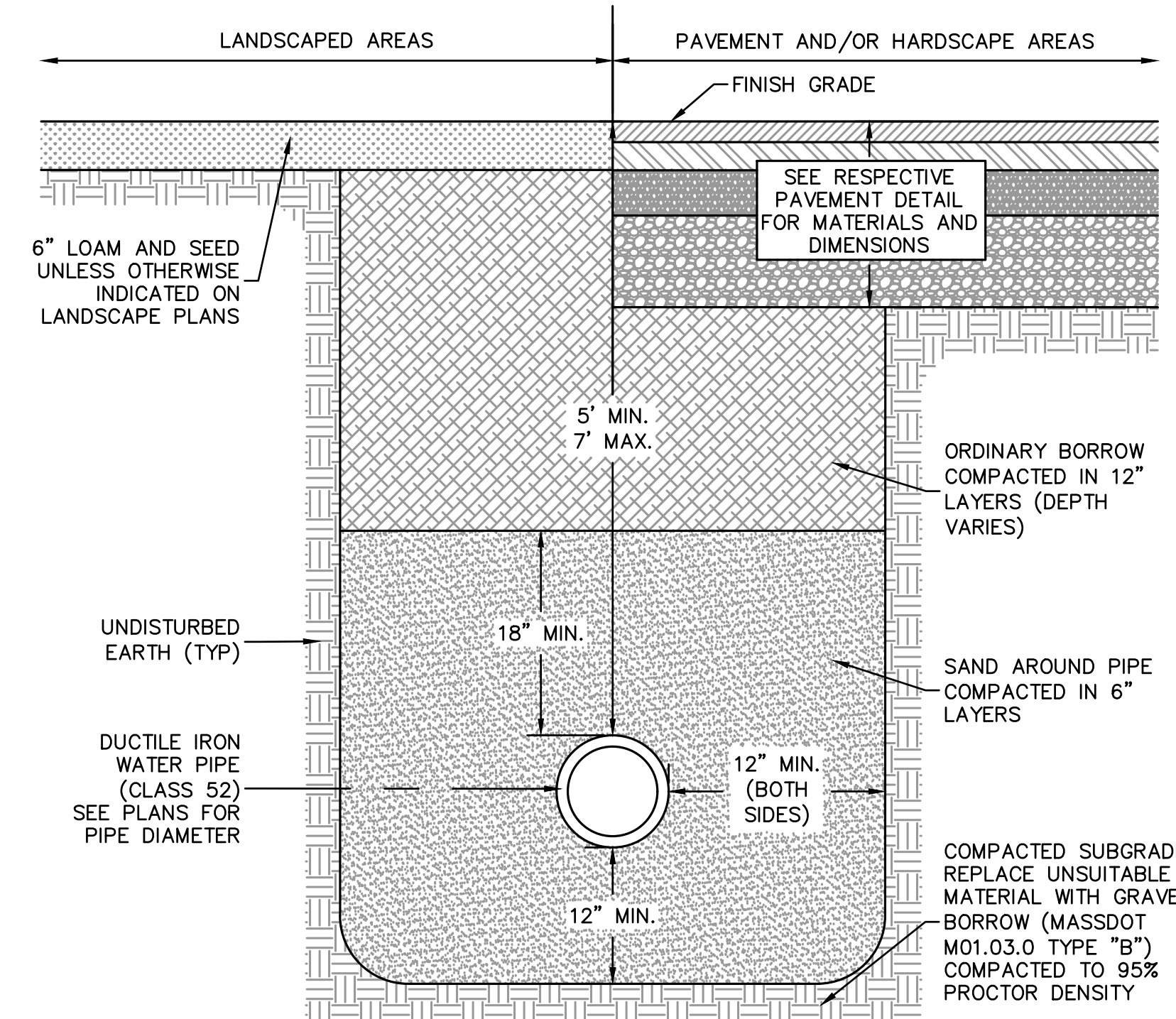

WATER TRENCH DETAIL

NOT TO SCALE

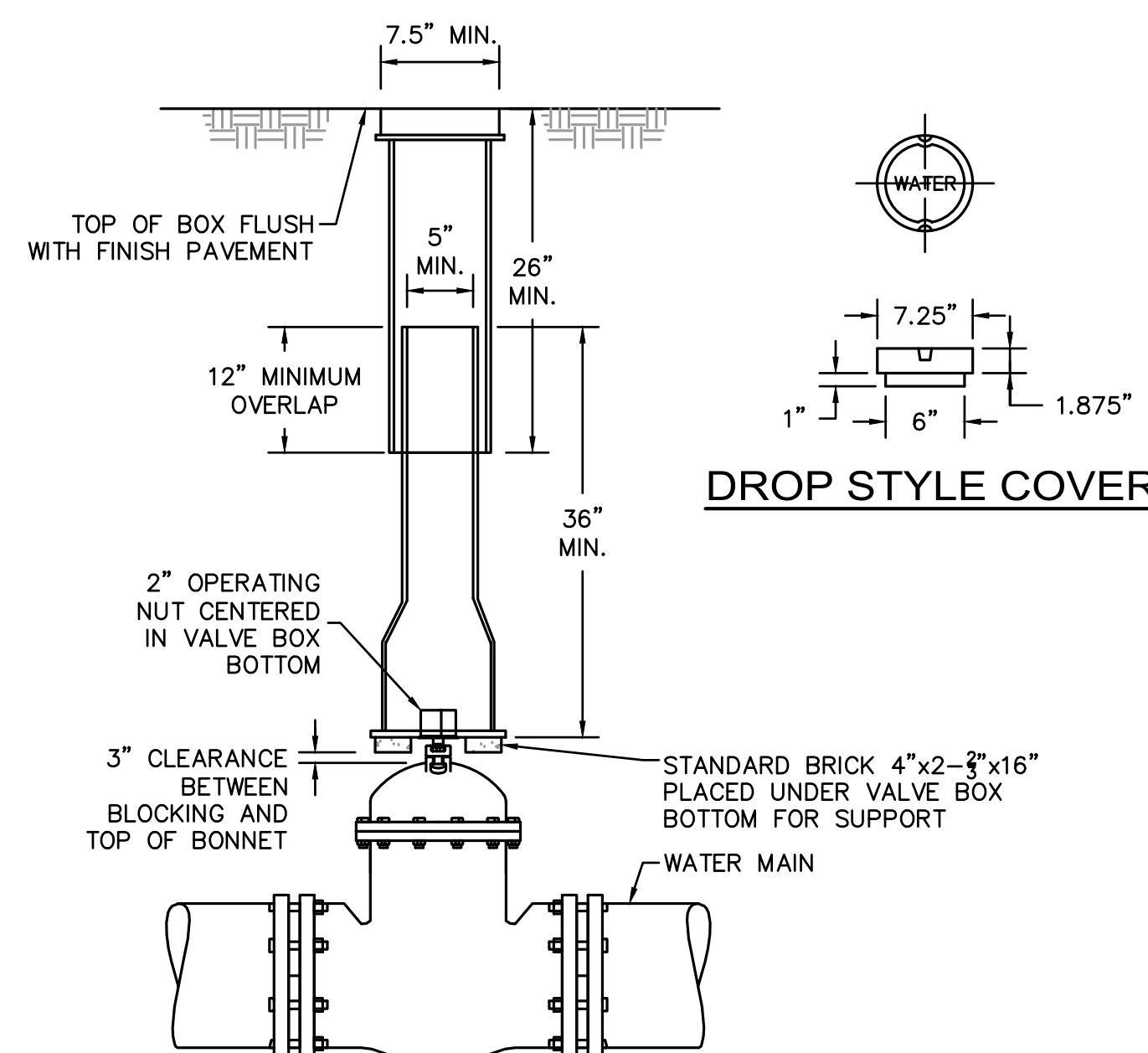

BOTTOM DETAIL

GATE VALVE BOX DETAIL
NOT TO SCALE

NOTES:

1. ALL WATER MAINS SHOULD HAVE A MINIMUM DEPTH OF 5' FROM TOP OF PIPE TO FINISH GRADE.
2. COVER MUST BE MARKED "WATER".

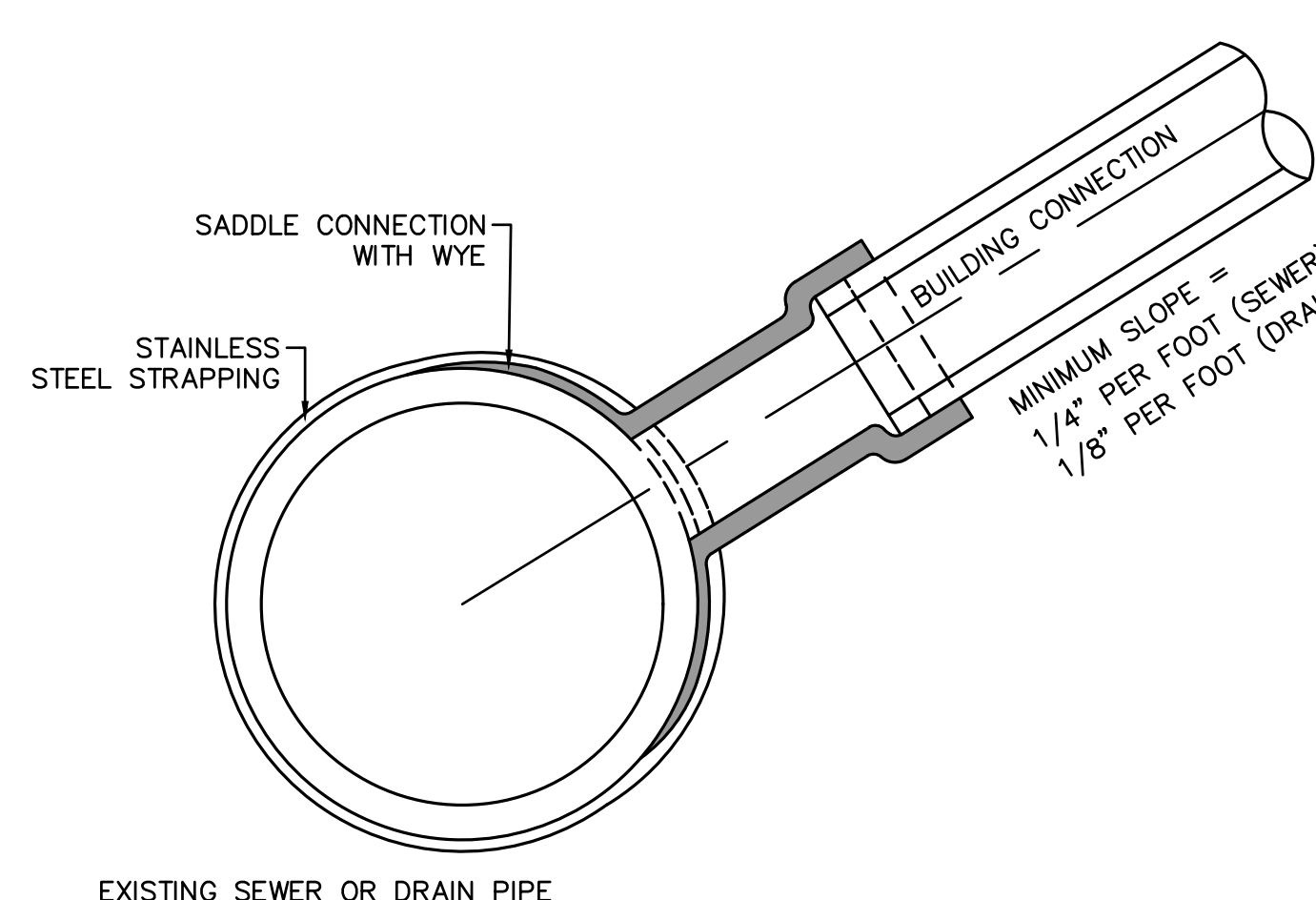

EXISTING SEWER OR DRAIN PIPE

NOTES:

1. FULL PVC OR IRON SADDLE MAY BE USED TO CONNECT TO EXISTING PVC, CLAY, CONCRETE OR IRON PIPE.
2. SADDLES MUST HAVE RUBBER GASKETS AND SHALL BE TIGHTENED WITH STRAPS. SADDLES WILL NOT BE CEMENTED ONTO THE PIPE.
3. FULL WYE CONNECTION FITTINGS MAY BE USED.
4. PIPE SHALL BE CUT TO CONFORM TO THE OPENING IN THE SADDLE.
5. CONNECTIONS DIRECTLY INTO THE EXISTING PIPE WITHOUT A SADDLE OR A FULL WYE FITTING ARE NOT ALLOWED.

TYPICAL SADDLE CONNECTION DETAIL TO EXISTING DRAIN OR SEWER (6" TO 15")
NOT TO SCALE

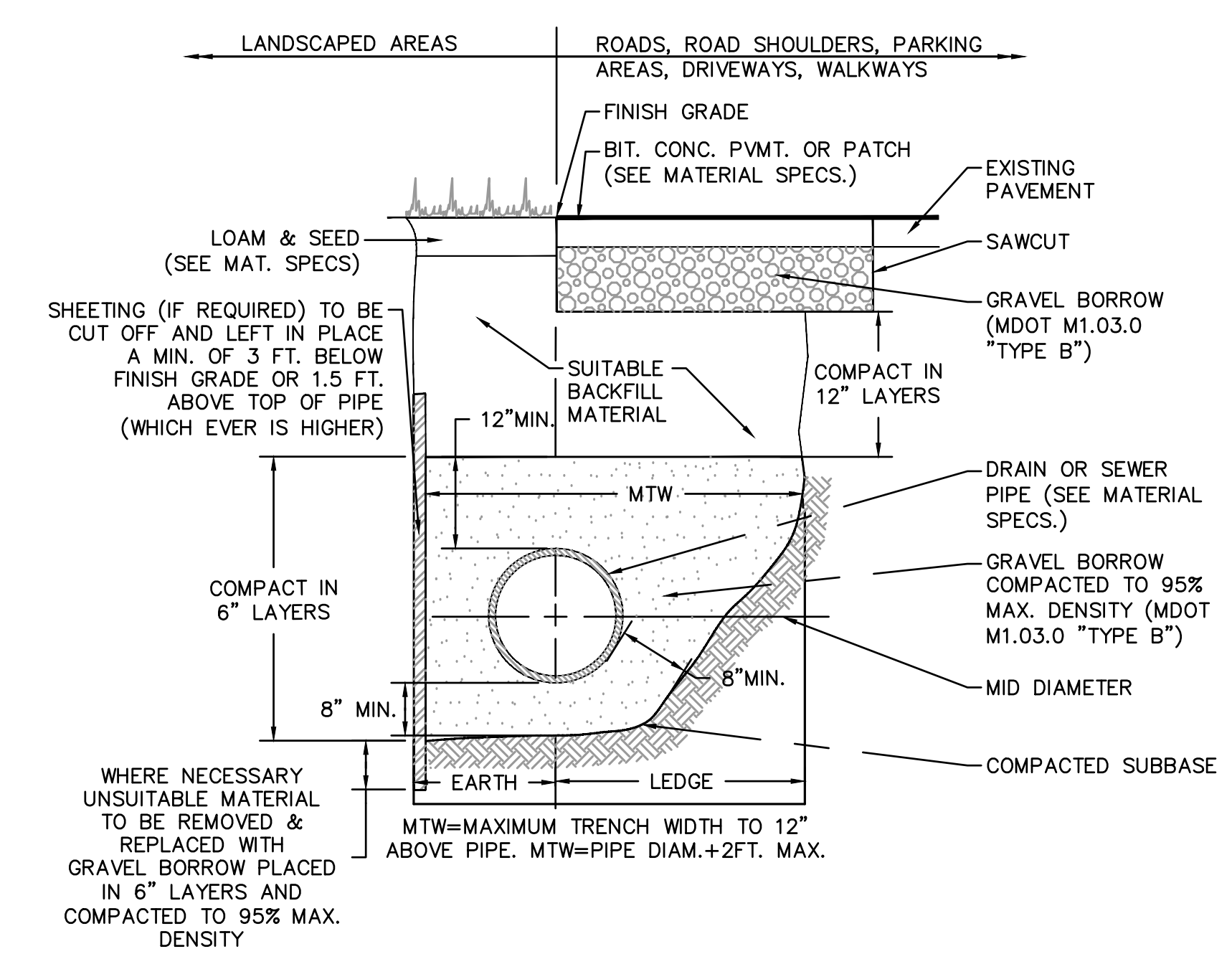

STANDARD TRENCH DETAIL FOR UTILITY PIPE

NOT TO SCALE

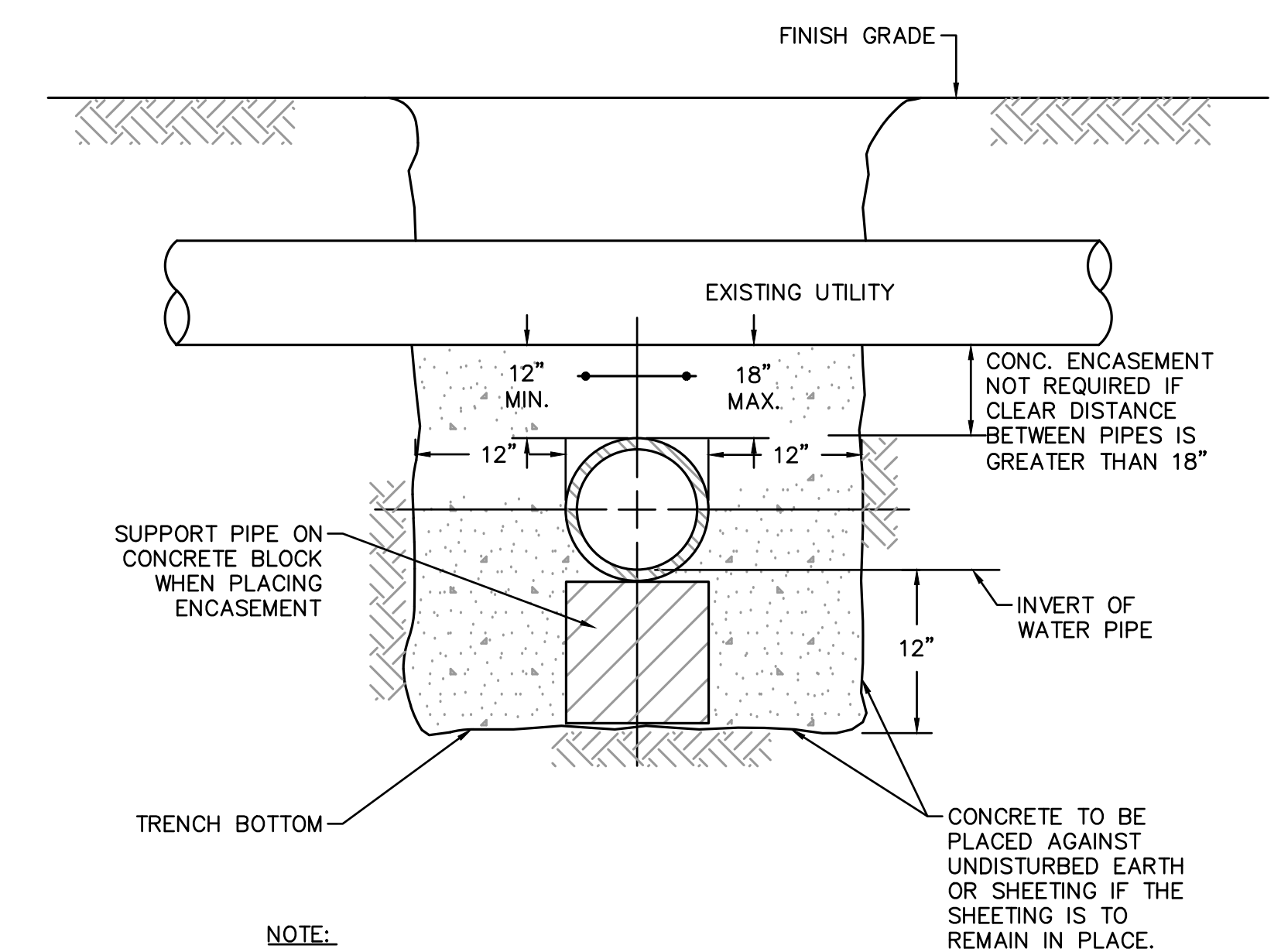

NOTE:

- PIPE MUST BE BRACED VERTICALLY & HORIZONTALLY TO PREVENT FLOATATION DURING PLACEMENT OF CONCRETE

CONCRETE ENCASEMENT DETAIL AT UTILITY CROSSINGS
NOT TO SCALE

2 HARBOR

329 NORTHERN AVE
BOSTON, MA 02210

OWNER
BCP-CG HARBOR PROPERTY LLC
C/O BEACON CAPITAL PARTNERS, LLC
200 STATE STREET, FIFTH FLOOR
BOSTON, MA 02109

ARCHITECT
HANDEL ARCHITECTS, LLP
69 CANAL ST, 2ND FLOOR
BOSTON, MA 02114
T: 617.851.4790

CONSULTING ARCHITECT
STUDIO ENÉE
460 HILLSIDE AVE
NEEDHAM, MA 02494
T: 781.858.3011

CONSULTING ARCHITECT
TRIA
21 DRYDOCK AVE, SUITE 330W
BOSTON, MA 02210
T: 617.530.1620

CIVIL ENGINEER
NITSCH ENGINEERING, INC.
2 CENTER PLAZA #430
BOSTON, MA 02108
T: 617.338.0063

MEP ENGINEER & CODE CONSULTANT
COSENTINI ASSOCIATES
101 FEDERAL ST #600
BOSTON, MA 02110
T: 617.748.7800

STRUCTURAL ENGINEER
DESMONE CONSULTING ENGINEERS
31 MILK ST, SUITE 1016
BOSTON, MA 02109
T: 617.936.4492

LANDSCAPE ARCHITECT
KLOPFER MARTIN DESIGN GROUP
69 CANAL ST, 2ND FLOOR
BOSTON, MA 02114
T: 617.227.2560

ENVELOPE CONSULTANT
CBI CONSULTING, LLC
250 DORCHESTER AVE
BOSTON, MA 02127
T: 617.268.8977

GEOTECHNICAL
HALEY & ALDRICH, INC.
465 MEDFORD ST, SUITE 2200
BOSTON, MA 02129
T: 617.866.7400

NOT FOR CONSTRUCTION

NO.	DATE	ISSUANCE
1	12/20/2019	CONCEPT PRICING
2	12/15/2020	50% SCHEMATIC DESIGN
3	2/18/2021	100% SCHEMATIC DESIGN
4	4/21/2021	EARLY SITE PACKAGE

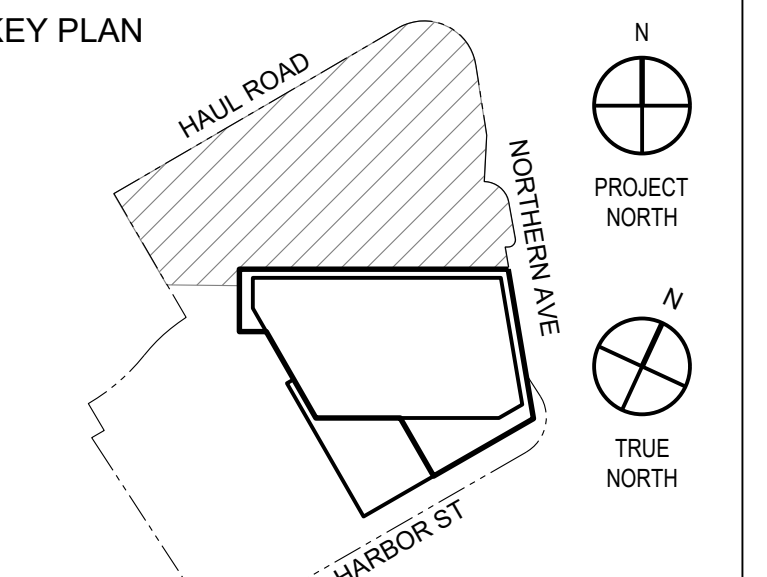

PROJECT DATUM: PROJ. 0'-0" = +16'-6" BCB
SCALE:
PROJECT NO: 1550
SEAL & SIGNATURE



DRAWING TITLE:
MATERIALS PLAN - 1

DRAWING NO:

L201

LEGEND

PROPERTY LINE - - - - -

1.0 PROPOSED SITE CONDITIONS BY OTHERS

- 1.1 PROPOSED STREET CURB
- 1.2 PROPOSED BUILDING. SEE ARCH DRAWINGS

2.0 PAVING

- 2.1 PRECAST CONCRETE UNIT PAVING - PEDESTRIAN
- 2.2 PRECAST CONCRETE UNIT PAVING - VEHICULAR
- 2.3 PERMEABLE PRECAST CONC. UNIT PAVING
- 2.4 C.I.P. CONCRETE PAVING
- 2.5 BITUMINOUS CONCRETE PAVING
- 2.6 DECOMPOSED GRANITE PAVING
- 2.7 GRANITE PAVING

3.0 STAIRS, RAMPS AND RAILS

- 3.1 C.I.P. CONCRETE STAIR
- 3.2 C.I.P. CONCRETE SLOPED WALK
- 3.3 NATURAL STONE LANDSCAPE STEPS
- 3.4 STAINLESS STEEL HANDRAIL
- 3.5 STAINLESS STEEL GUARDRAIL

4.0 WALLS AND CURBS

- 4.1 NATURAL STONE WALL
- 4.2 BLACKENED STEEL
- 4.3 NATURAL STONE BLOCKS
- 4.4 C.I.P. CONCRETE WALL
- 4.5 RAISED GRANITE CURB
- 4.6 FLUSH GRANITE CURB
- 4.7 BLACKENED STEEL AND NATURAL STONE PLANTER WALLS
- 4.8 SHEET PILE RETAINING WALL

5.0 SIGNAGE

- 5.1 CUSTOM MONUMENTAL SIGN

6.0 SITE LIGHTING, ELECTRICAL

- 6.1 ARCHITECTURAL DOWNLIGHT GATENERY SYSTEM WITH POLES
- 6.2 ROADWAY LIGHTING
- 6.3 RECESSED INGRADE TREE UPLIGHTS
- 6.4 50' HIGH MAST POLE LIGHTS
- 6.5 LOW LEVEL BOLLARD LIGHTS
- 6.6 16' PEDESTRIAN ARCHITECTURAL POLE
- 6.7 INGRADE LOW LEVEL MARKER LIGHTS
- 6.8 ELECTRIC VEHICLE CHARGING STATION (TOTAL OF 7 STATIONS FOR 18 VEHICLES)

7.0 FENCING

- 7.1 PERFORATED METAL PANEL ART WALL - - - - -
- 7.2 CHAIN LINK FENCE

8.0 SITE FURNISHING

- 8.1 BOLLARD
- 8.2 BIKE RACK (TOTAL OF 10)
- 8.3 FIXED BENCH, LINEAR SEATING
- 8.4 BENCHES, TABLES, CHAIRS
- 8.5 PAVILION / SHADE STRUCTURE
- 8.6 BIKE SHARE DOCKING STATION (19 DOCKS)

9.0 PLANTING - SEE PLANTING PLAN

- 9.1 PERENNIAL / GRASS PLANTING
- 9.2 SHRUB PLANTING
- 9.3 TREE PLANTING IN SAND BASED STRUCTURAL SOIL (TOTAL OF 55)
- 9.4 TREE PLANTING IN PLANTING BED (TOTAL OF 137)



1 MATERIALS PLAN - 1
1" = 20'

MATCHLINE. SEE L202

2 HARBOR

329 NORTHERN AVE
BOSTON, MA 02210

OWNER
BCP-CG HARBOR PROPERTY LLC
C/O BEACON CAPITAL PARTNERS, LLC
200 STATE STREET, FIFTH FLOOR
BOSTON, MA 02109

ARCHITECT
HANDEL ARCHITECTS, LLP
69 CANAL ST, 2ND FLOOR
BOSTON, MA 02114
T: 617.651.4790

CONSULTING ARCHITECT
STUDIO ENÉE
460 HILLSIDE AVE
NEEDHAM, MA 02494
T: 781.858.3011

CONSULTING ARCHITECT
TRIA
21 DRYDOCK AVE, SUITE 330W
BOSTON, MA 02210
T: 617.530.1620

CIVIL ENGINEER
NITSCH ENGINEERING, INC.
2 CENTER PLAZA #430
BOSTON, MA 02108
T: 617.338.0063

MEP ENGINEER & CODE CONSULTANT
COSENTINI ASSOCIATES
101 FEDERAL ST #600
BOSTON, MA 02110
T: 617.748.7800

STRUCTURAL ENGINEER
DESIMONE CONSULTING ENGINEERS
31 MILK ST, SUITE 1016
BOSTON, MA 02109
T: 617.936.4492

LANDSCAPE ARCHITECT
KLOPFER MARTIN DESIGN GROUP
69 CANAL ST, 2ND FLOOR
BOSTON, MA 02114
T: 617.227.2560

ENVELOPE CONSULTANT
CBI CONSULTING, LLC
250 DORCHESTER AVE
BOSTON, MA 02127
T: 617.268.8977

GEOTECHNICAL
HALEY & ALDRICH, INC.
465 MEDFORD ST, SUITE 2200
BOSTON, MA 02129
T: 617.866.7400

NOT FOR CONSTRUCTION

NO.	DATE	ISSUANCE
1	12/20/2019	CONCEPT PRICING
2	12/15/2020	50% SCHEMATIC DESIGN
3	2/18/2021	100% SCHEMATIC DESIGN
4	4/21/2021	EARLY SITE PACKAGE

KEY PLAN

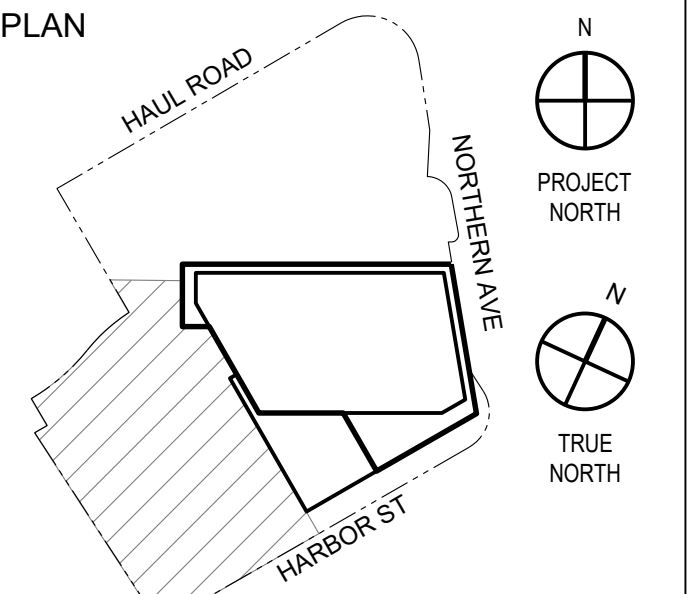

PROJECT DATUM: PROJ. 0'-0" = +16'-6" BCB
SCALE:
PROJECT NO: 1550
SEAL & SIGNATURE



DRAWING TITLE:
MATERIALS PLAN - 2

DRAWING NO:

L202

LEGEND

PROPERTY LINE

1.0 PROPOSED SITE CONDITIONS BY OTHERS

- 1.1 PROPOSED STREET CURB
- 1.2 PROPOSED BUILDING. SEE ARCH DRAWINGS

2.0 PAVING

- 2.1 PRECAST CONCRETE UNIT PAVING - PEDESTRIAN
- 2.2 PRECAST CONCRETE UNIT PAVING - VEHICULAR
- 2.3 PERMEABLE PRECAST CONC. UNIT PAVING
- 2.4 C.I.P. CONCRETE PAVING
- 2.5 BITUMINOUS CONCRETE PAVING
- 2.6 DECOMPOSED GRANITE PAVING
- 2.7 GRANITE PAVING

3.0 STAIRS, RAMPS AND RAILS

- 3.1 C.I.P. CONCRETE STAIR
- 3.2 C.I.P. CONCRETE SLOPED WALK
- 3.3 NATURAL STONE LANDSCAPE STEPS
- 3.4 STAINLESS STEEL HANDRAIL
- 3.5 STAINLESS STEEL GUARDRAIL

4.0 WALLS AND CURBS

- 4.1 NATURAL STONE WALL
- 4.2 BLACKENED STEEL
- 4.3 NATURAL STONE BLOCKS
- 4.4 C.I.P. CONCRETE WALL
- 4.5 RAISED GRANITE CURB
- 4.6 FLUSH GRANITE CURB
- 4.7 BLACKENED STEEL AND NATURAL STONE PLANTER WALLS
- 4.8 SHEET PILE RETAINING WALL

5.0 SIGNAGE

- 5.1 CUSTOM MONUMENTAL SIGN

6.0 SITE LIGHTING, ELECTRICAL

- 6.1 ARCHITECTURAL DOWNLIGHT GATENERY SYSTEM WITH POLES
- 6.2 ROADWAY LIGHTING
- 6.3 RECESSED INGRADE TREE UPLIGHTS
- 6.4 50' HIGH MAST POLE LIGHTS
- 6.5 LOW LEVEL BOLLARD LIGHTS
- 6.6 16' PEDESTRIAN ARCHITECTURAL POLE
- 6.7 INGRADE LOW LEVEL MARKER LIGHTS
- 6.8 ELECTRIC VEHICLE CHARGING STATION (TOTAL OF 7 STATIONS FOR 18 VEHICLES)

7.0 FENCING

- 7.1 PERFORATED METAL PANEL ART WALL
- 7.2 CHAIN LINK FENCE

8.0 SITE FURNISHING

- 8.1 BOLLARD
- 8.2 BIKE RACK (TOTAL OF 10)
- 8.3 FIXED BENCH, LINEAR SEATING
- 8.4 BENCHES, TABLES, CHAIRS
- 8.5 PAVILION / SHADE STRUCTURE
- 8.6 BIKE SHARE DOCKING STATION (19 DOCKS)

9.0 PLANTING - SEE PLANTING PLAN

- 9.1 PERENNIAL / GRASS PLANTING
- 9.2 SHRUB PLANTING
- 9.3 TREE PLANTING IN SAND BASED STRUCTURAL SOIL (TOTAL OF 55)
- 9.4 TREE PLANTING IN PLANTING BED (TOTAL OF 137)

MATCHLINE. SEE L201

INTEGRATED LIGHTING WITH CANOPY

1 MATERIALS PLAN - 2
1" = 20'

9 STORY CONCRETE
New or Formerly
ECONOMIC DEVELOPMENT
AND INDUSTRIAL
CORPORATION OF BOSTON
BOOK 8960 PAGE 4184
PARCEL ID 060221150

#12 CHANNEL STREET

HARBOR STREET

NORTHERN AVENUE

HAUL ROAD

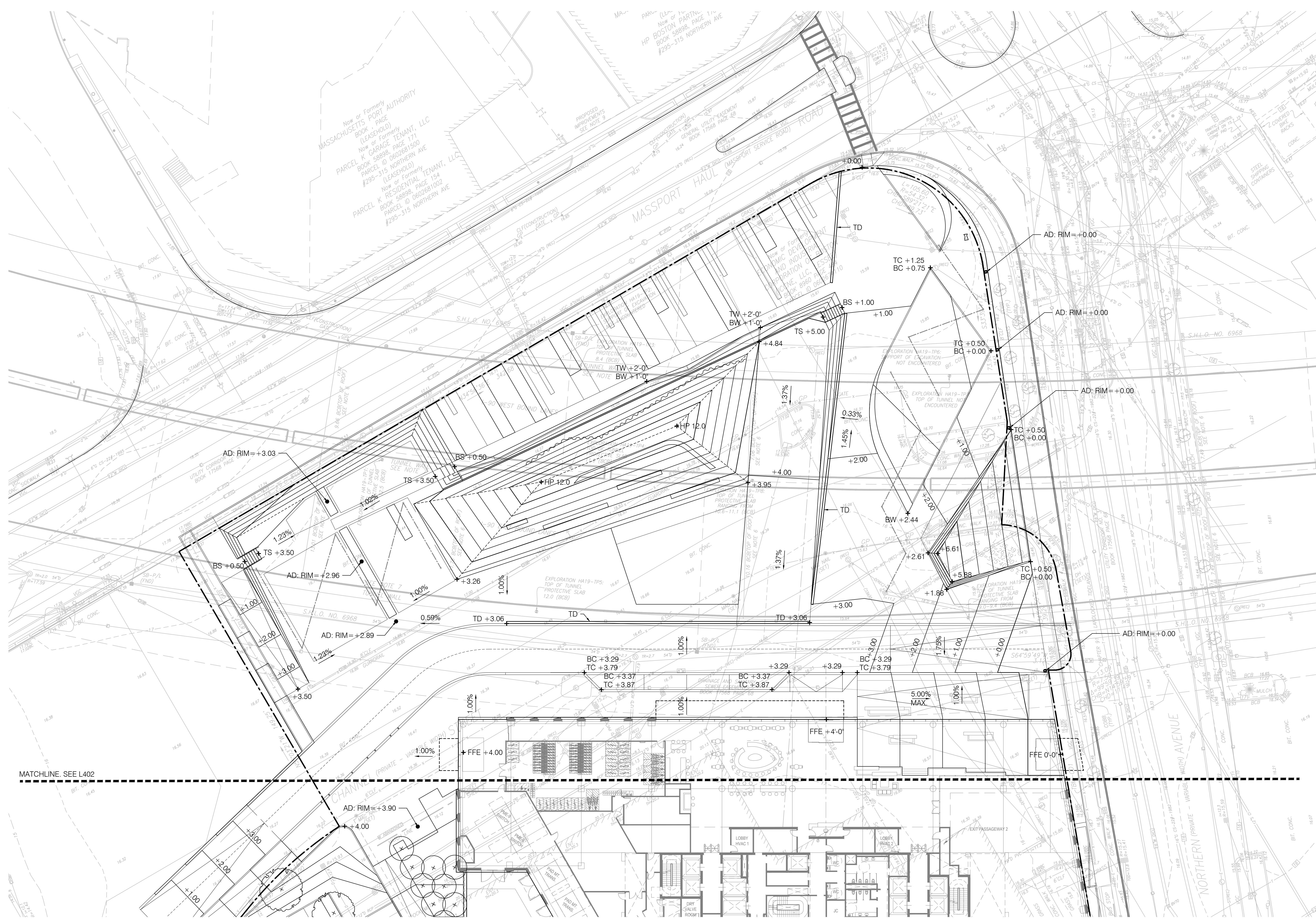

1 GRADING PLAN - 1
SCALE: 1"=20'

LEGEND

PROPERTY LINE

2 HARBOR

329 NORTHERN AVE
BOSTON, MA 02210

OWNER
BCP-CG HARBOR PROPERTY LLC
C/O BEACON CAPITAL PARTNERS, LLC
200 STATE STREET, FIFTH FLOOR
BOSTON, MA 02109

ARCHITECT
HANDEL ARCHITECTS, LLP
69 CANAL ST., 2ND FLOOR
BOSTON, MA 02114
T: 617.651.4790

CONSULTING ARCHITECT
STUDIO ENÉE
460 HILLSIDE AVE
NEEDHAM, MA 02494
T: 781.858.3011

CONSULTING ARCHITECT
TRIA
21 DRYDOCK AVE, SUITE 330W
BOSTON, MA 02210
T: 617.530.1620

CIVIL ENGINEER
NITSCH ENGINEERING, INC.
2 CENTER PLAZA #430
BOSTON, MA 02108
T: 617.338.0063

MEP ENGINEER & CODE CONSULTANT
COSENTINI ASSOCIATES
101 FEDERAL ST #600
BOSTON, MA 02110
T: 617.748.7800

STRUCTURAL ENGINEER
DESIMONE CONSULTING ENGINEERS
31 MILK ST., SUITE 1016
BOSTON, MA 02109
T: 617.936.4492

LANDSCAPE ARCHITECT
KLOPFER MARTIN DESIGN GROUP
69 CANAL ST., 2ND FLOOR
BOSTON, MA 02114
T: 617.227.2560

ENVELOPE CONSULTANT
CBI CONSULTING, LLC
250 DORCHESTER AVE
BOSTON, MA 02127
T: 617.268.8977

GEOTECHNICAL
HALEY & ALDRICH, INC.
465 MEDFORD ST., SUITE 2200
BOSTON, MA 02129
T: 617.866.7400

NOT FOR CONSTRUCTION

NO.	DATE	ISSUANCE
1	12/20/2019	CONCEPT PRICING
2	12/15/2020	50% SCHEMATIC DESIGN
3	2/18/2021	100% SCHEMATIC DESIGN
4	4/21/2021	EARLY SITE PACKAGE

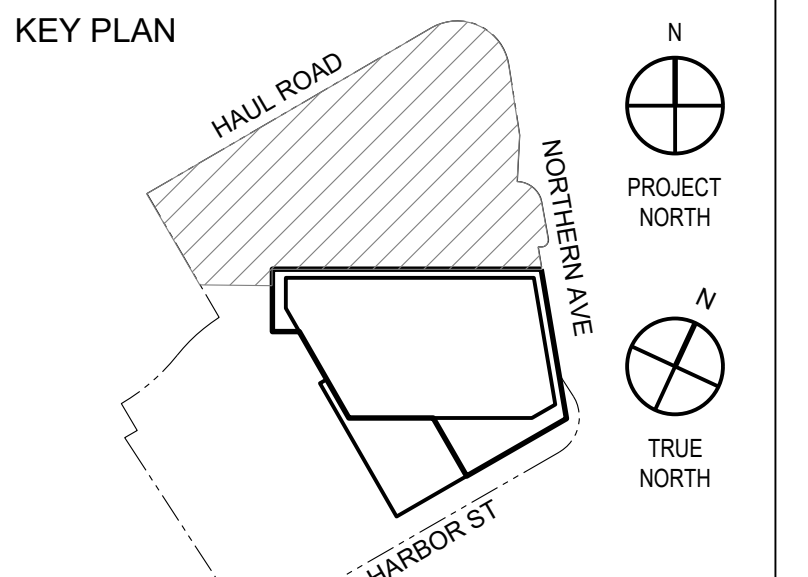

PROJECT DATUM: PROJ. 0'-0" = +16'-6" BCB
SCALE: AS NOTED
PROJECT NO: 1550
SEAL & SIGNATURE

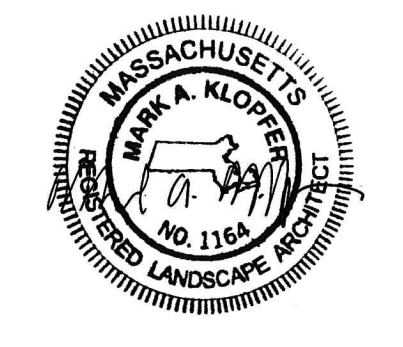

DRAWING TITLE:
GRADING PLAN - 1

DRAWING NO:
L401

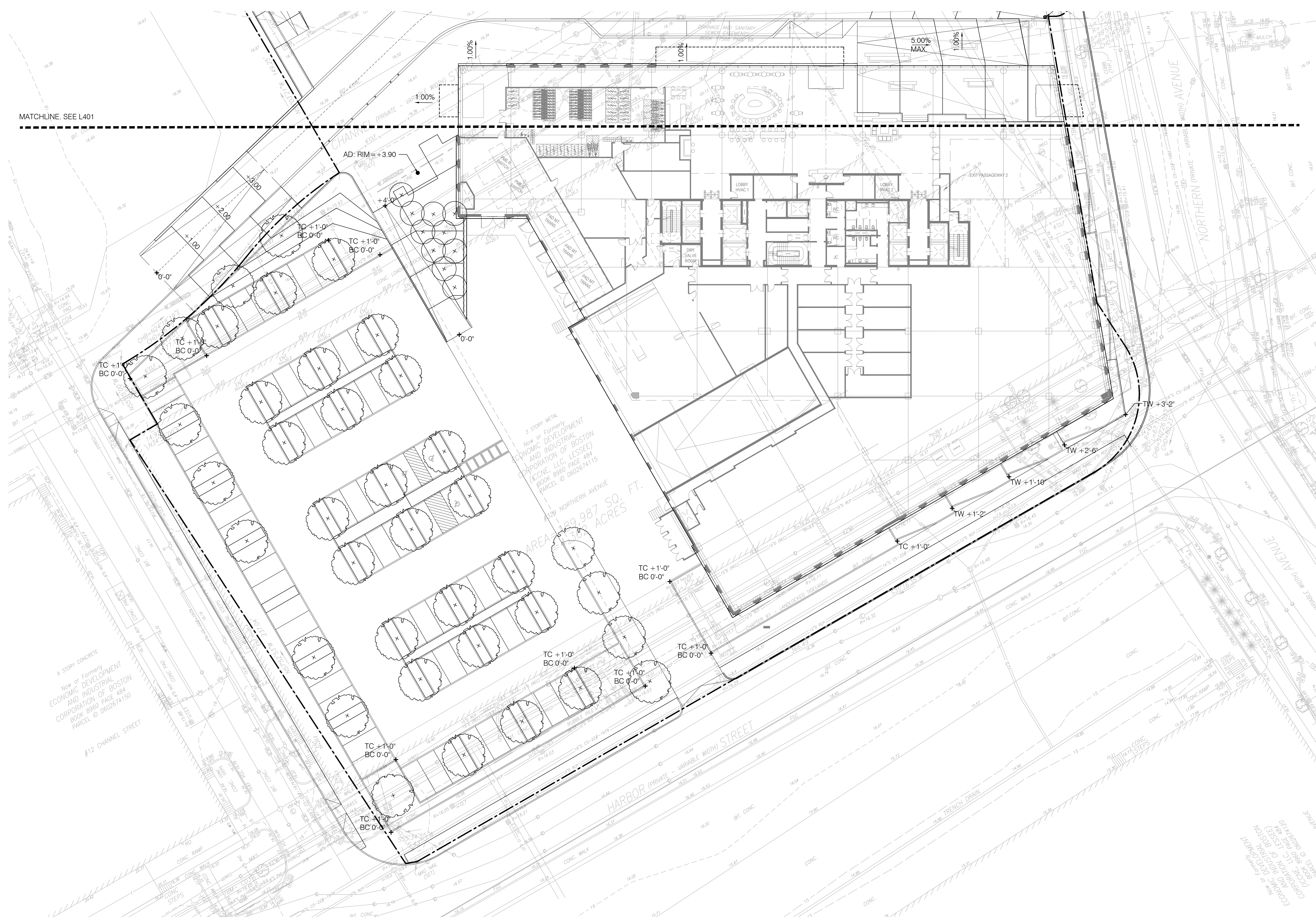

LEGEND
PROPERTY LINE

2 HARBOR

329 NORTHERN AVE
BOSTON, MA 02210

OWNER
BCP-CG HARBOR PROPERTY LLC
C/O BEACON CAPITAL PARTNERS, LLC
200 STATE STREET, FIFTH FLOOR
BOSTON, MA 02109

ARCHITECT
HANDEL ARCHITECTS, LLP
69 CANAL ST., 2ND FLOOR
BOSTON, MA 02114
T: 617.651.4790

CONSULTING ARCHITECT
STUDIO ENÉE
460 HILLSIDE AVE
NEEDHAM, MA 02494
T: 781.858.3011

CONSULTING ARCHITECT
TRIA
21 DRYDOCK AVE, SUITE 330W
BOSTON, MA 02210
T: 617.530.1620

CIVIL ENGINEER
NITSCH ENGINEERING, INC.
2 CENTER PLAZA #430
BOSTON, MA 02108
T: 617.338.0063

MEP ENGINEER & CODE CONSULTANT
COSENTINI ASSOCIATES
101 FEDERAL ST #600
BOSTON, MA 02110
T: 617.748.7600

STRUCTURAL ENGINEER
DESIMONE CONSULTING ENGINEERS
31 MILK ST, SUITE 1016
BOSTON, MA 02109
T: 617.936.4492

LANDSCAPE ARCHITECT
KLOPFER MARTIN DESIGN GROUP
69 CANAL ST., 2ND FLOOR
BOSTON, MA 02114
T: 617.227.2560

ENVELOPE CONSULTANT
CBI CONSULTING, LLC
250 DORCHESTER AVE
BOSTON, MA 02127
T: 617.268.8977

GEOTECHNICAL
HALEY & ALDRICH, INC.
465 MEDFORD ST, SUITE 2200
BOSTON, MA 02129
T: 617.866.7400

NOT FOR CONSTRUCTION

NO.	DATE	ISSUANCE
1	12/20/2019	CONCEPT PRICING
2	12/15/2020	50% SCHEMATIC DESIGN
3	2/18/2021	100% SCHEMATIC DESIGN
4	4/21/2021	EARLY SITE PACKAGE

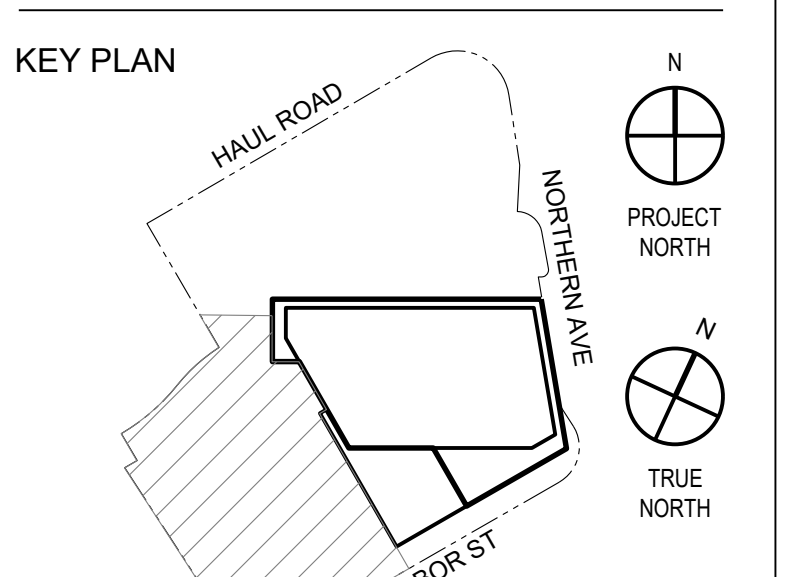

PROJECT DATUM: PROJ. 0'-0" = +16'-6" BCB
SCALE: AS NOTED
PROJECT NO: 1550
SEAL & SIGNATURE



DRAWING TITLE:
GRADING PLAN - 2

DRAWING NO:
L402

1 GRADING PLAN - 2
SCALE: 1" = 20'

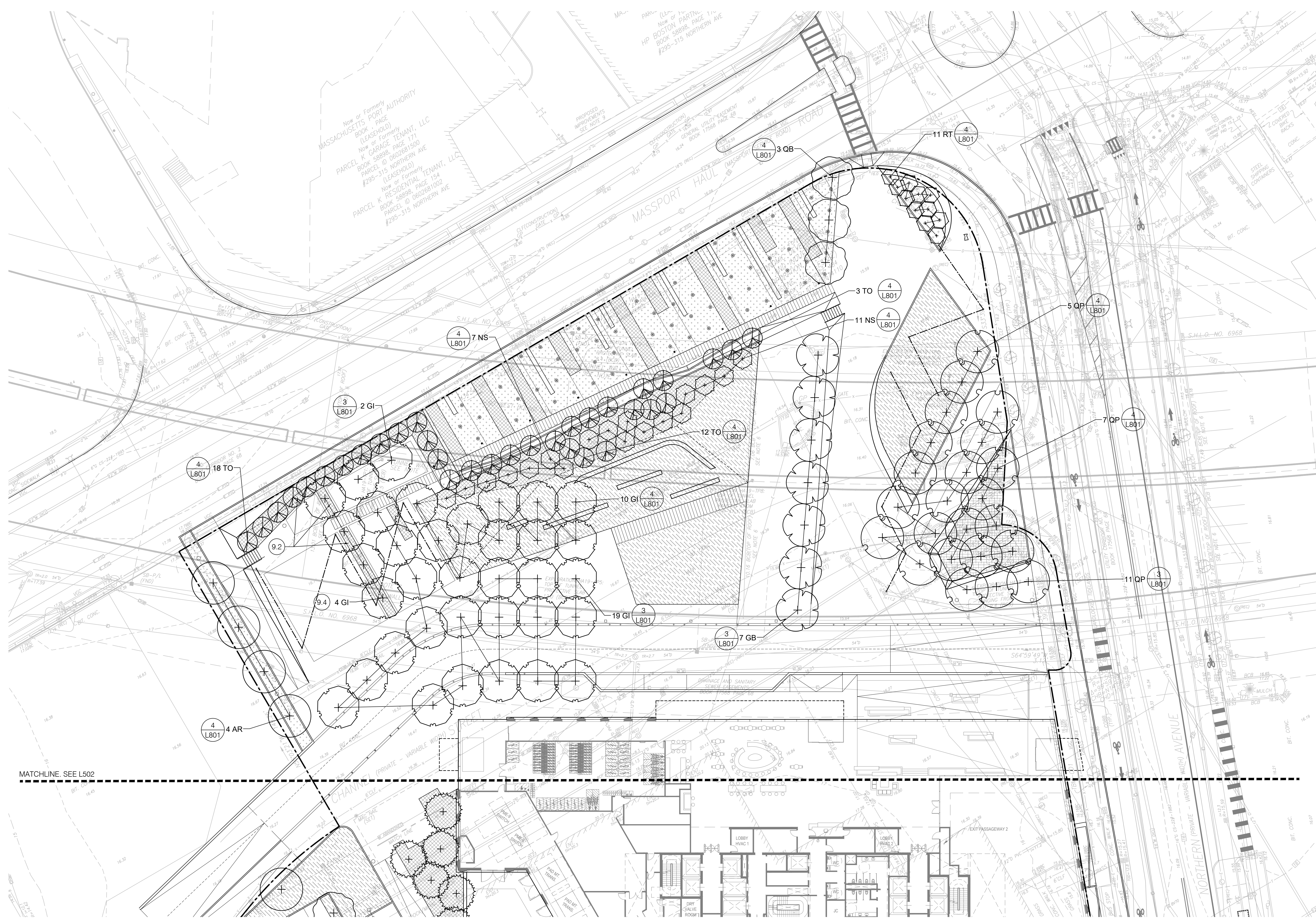

LEGEND

PROPERTY LINE

2 HARBOR

329 NORTHERN AVE
BOSTON, MA 02210

OWNER
BCP-CG HARBOR PROPERTY LLC
C/O BEACON CAPITAL PARTNERS, LLC
200 STATE STREET, FIFTH FLOOR
BOSTON, MA 02109

ARCHITECT
HANDEL ARCHITECTS, LLP
69 CANAL ST., 2ND FLOOR
BOSTON, MA 02214
T: 617.651.4790

CONSULTING ARCHITECT
STUDIO ENÉE
460 HILLSIDE AVE
NEEDHAM, MA 02494
T: 781.858.3011

CONSULTING ARCHITECT
TRIA
21 DRYDOCK AVE, SUITE 330W
BOSTON, MA 02210
T: 617.530.1620

CIVIL ENGINEER
NITSCH ENGINEERING, INC.
2 CENTER PLAZA #430
BOSTON, MA 02108
T: 617.338.0063

MEP ENGINEER & CODE CONSULTANT
COSENTINI ASSOCIATES
101 FEDERAL ST #600
BOSTON, MA 02110
T: 617.748.7800

STRUCTURAL ENGINEER
DESIMONE CONSULTING ENGINEERS
31 MILK ST., SUITE 1016
BOSTON, MA 02109
T: 617.936.4492

LANDSCAPE ARCHITECT
KLOPFER MARTIN DESIGN GROUP
69 CANAL ST., 2ND FLOOR
BOSTON, MA 02114
T: 617.227.2560

ENVELOPE CONSULTANT
CBI CONSULTING, LLC
250 DORCHESTER AVE
BOSTON, MA 02127
T: 617.268.8977

GEOTECHNICAL
HALEY & ALDRICH, INC.
465 MEDFORD ST., SUITE 2200
BOSTON, MA 02129
T: 617.866.7400

NOT FOR CONSTRUCTION

NO.	DATE	ISSUANCE
1	12/20/2019	CONCEPT PRICING
2	12/15/2020	50% SCHEMATIC DESIGN
3	2/18/2021	100% SCHEMATIC DESIGN
4	4/21/2021	EARLY SITE PACKAGE

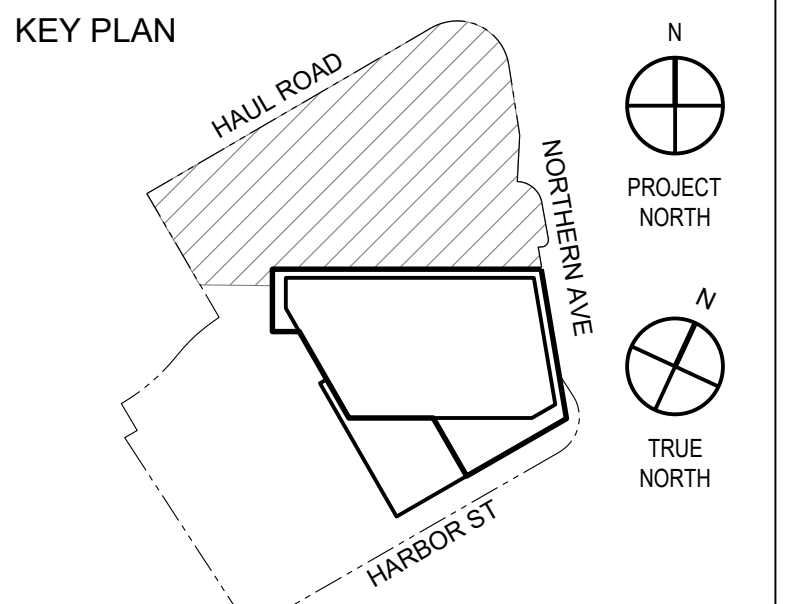

PROJECT DATUM: PROJ. 0'-0" = +16'-6" BCB
SCALE:
PROJECT NO: 1550
SEAL & SIGNATURE

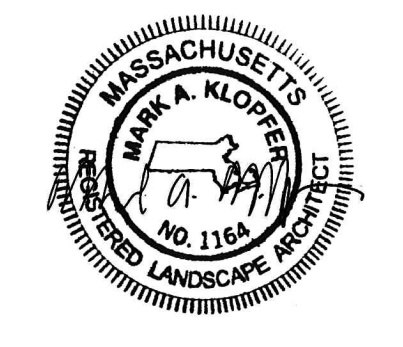

DRAWING TITLE:
PLANTING PLAN - 1

DRAWING NO:
L601

PLANT SCHEDULE

TREES	QTY	BOTANICAL NAME	COMMON NAME
AR	13	Acer rubrum	Red Maple
GB	7	Ginkgo biloba	Maidenhair Tree
GI	53	Gleditsia triacanthos inermis 'Suncole'	Sunburst Honey Locust
NS	18	Nyssa sylvatica	Tupelo
PB	6	Picea mariana	Black Spruce
QB	21	Quercus bicolor	Swamp White Oak
QP	23	Quercus palustris	Pin Oak
RT	11	Rhus typhina	Staghorn Sumac
TO	33	Thuja occidentalis	American Arborvitae
UA	7	Ulmus americana	American Elm

SCHEDULE NOTES:

- ULMUS CULTIVARS SHALL BE A COMBINATION OF VALLEY FORGE, PRINCETON, AND ACCOLADE.
- ACER CULTIVAR SHALL BE A MIX OF NORTHWIND, OCTOBER GLORY, AND AUTUMN SPIRE.

- 1 L801 NO-MOW GRASS MIX:
WINDWARD CHEWINGS FESCUE - FESTUCA COMMUTATA
SHEEP FESCUE - FESTUCA OVINA
ALURIRA HARD FESCUE - FESTUCA BREVIPILA (F. LONGIFOLIA)
RHINO HARD FESCUE - FESTUCA BREVIPILA (F. LONGIFOLIA)
SEABREEZE SLENDER CREEPING RED FESCUE - FESTUCA RUBRA
LUSTROUS CREEPING RED FESCUE - FESTUCA RUBRA, SUBSP. RUBRA

- 1 L801 SHADE PERENNIAL MIX:
HAY-SCENTED FERN - DENNSTAEDTIA PUNCTILOBULA
CINNAMON FERN - OSMUNDA CINNAMOMEA
OSTRICH FERN - MATTEUCCIA STRUTHIOPTERIS
LADY FERN - ATHYRIUM FILIX-FEMINA
BLACK COHOSH - ACTAEA RACEMOSA

- 3 L801 TREE PLANTING IN SAND-BASED STRUCTURAL SOIL
- 4 L801 TREE PLANTING IN PLANTING BED

- 2 L801 SHRUB MIX:
RED CHOKEBERRY - ARONIA ARUBUTIFOLIA
DWARF FOTHERGILLA - FOTHERGILLA GARDENII
INKBERRY - ILEX GLABRA
WINTERBERRY - ILEX VERTICILLATA
AMERICAN WITCH-HAZEL - HAMAMELIS VIRGINIANA
FRAGRANT SUMAC - RHUS AROMATICA 'GRO-LOW'
HYDRANGEA ARBORESCENS 'ANNABELLE' - 'ANNABELLE' HYDRANGEA

- 1 L801 TALL GRASS MIX:
SWITCHGRASS - PANICUM VIRGATUM
TUFTED HAIR GRASS - DESCHAMPSIA CESPITOSA
CANADA BLUEJOINT - CALAMAGROSTIS CANADENSIS
BUNCHED BROOM-SEDGE - ANDROPOGON VIRGINICUS

1 PLANTING PLAN - 1
1" = 20'

2 HARBOR

329 NORTHERN AVE
BOSTON, MA 02210

OWNER
BCP-CG HARBOR PROPERTY LLC
C/O BEACON CAPITAL PARTNERS, LLC
200 STATE STREET, FIFTH FLOOR
BOSTON, MA 02109

ARCHITECT
HANDEL ARCHITECTS, LLP
69 CANAL ST., 2ND FLOOR
BOSTON, MA 02114
T: 617.651.4790

CONSULTING ARCHITECT
STUDIO ENÉE
460 HILLSIDE AVE
NEEDHAM, MA 02494
T: 781.858.3011

CONSULTING ARCHITECT
TRIA
21 DRYDOCK AVE, SUITE 330W
BOSTON, MA 02210
T: 617.530.1620

CIVIL ENGINEER
NITSCH ENGINEERING, INC.
2 CENTER PLAZA #430
BOSTON, MA 02108
T: 617.338.0063

MEP ENGINEER & CODE CONSULTANT
COSENTINI ASSOCIATES
101 FEDERAL ST #600
BOSTON, MA 02110
T: 617.748.7800

STRUCTURAL ENGINEER
DESIMONE CONSULTING ENGINEERS
31 MILK ST., SUITE 1016
BOSTON, MA 02109
T: 617.936.4492

LANDSCAPE ARCHITECT
KLOPFER MARTIN DESIGN GROUP
69 CANAL ST., 2ND FLOOR
BOSTON, MA 02114
T: 617.227.2560

ENVELOPE CONSULTANT
CBI CONSULTING, LLC
250 DORCHESTER AVE
BOSTON, MA 02127
T: 617.268.8977

GEOTECHNICAL
HALEY & ALDRICH, INC.
465 MEDFORD ST., SUITE 2200
BOSTON, MA 02129
T: 617.866.7400

NOT FOR CONSTRUCTION

NO.	DATE	ISSUANCE
1	12/20/2019	CONCEPT PRICING
2	12/15/2020	50% SCHEMATIC DESIGN
3	2/18/2021	100% SCHEMATIC DESIGN
4	4/21/2021	EARLY SITE PACKAGE

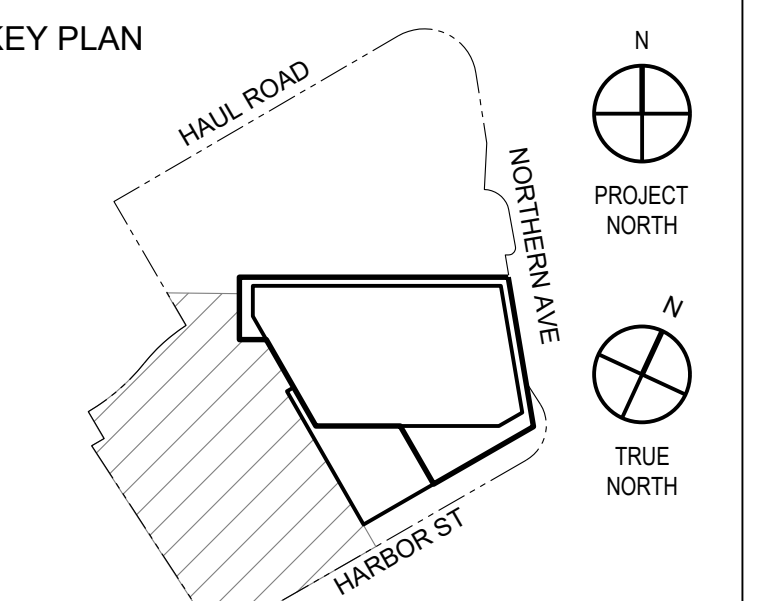

PROJECT DATUM: PROJ. 0'-0" = +16'-6" BCB
SCALE:
PROJECT NO: 1550
SEAL & SIGNATURE



DRAWING TITLE:
PLANTING PLAN - 2

DRAWING NO:

L602

LEGEND

PROPERTY LINE

PLANT SCHEDULE

TREES	QTY	BOTANICAL NAME	COMMON NAME
AR	13	Acer rubrum	Red Maple
GB	7	Ginkgo biloba	Maidenhair Tree
GI	53	Gleditsia triacanthos inermis 'Suncole'	Sunburst Honey Locust
NS	18	Nyssa sylvatica	Tupelo
PB	6	Picea mariana	Black Spruce
QB	21	Quercus bicolor	Swamp White Oak
QP	23	Quercus palustris	Pin Oak
RT	11	Rhus typhina	Staghorn Sumac
TO	33	Thuja occidentalis	American Arborvitae
UA	7	Ulmus americana	American Elm

SCHEDULE NOTES:

- ULMUS CULTIVARS SHALL BE A COMBINATION OF 'VALLEY FORGE', 'PRINCETON', AND 'ACCOLADE'.
- ACER CULTIVAR SHALL BE A MIX OF 'NORTHWIND', 'OCTOBER GLORY', AND 'AUTUMN SPIRE'.

1 L801 NO-MOW GRASS MIX:

WINDWARD CHEWINGS FESCUE - FESTUCA COMMUTATA
SHEEP FESCUE - FESTUCA OVINA
ALURRA HARD FESCUE - FESTUCA BREVIPILA (F. LONGIFOLIA)
RHINO HARD FESCUE - FESTUCA BREVIPILA (F. LONGIFOLIA)
SEABREEZE SLENDER CREEPING RED FESCUE - FESTUCA RUBRA
LUSTROUS CREEPING RED FESCUE - FESTUCA RUBRA, SUBSP. RUBRA

1 L801 SHADE PERENNIAL MIX:

HAY-SCENTED FERN - DENNSTAEDTIA PUNCTILOBULA
CINNAMON FERN - OSMUNDA CINNAMOMEA
OSTRICH FERN - MATTEUCCIA STRUTHIOPTERIS
LADY FERN - ATHYRIUM FILIX-FEMINA
BLACK COHOSH - ACTAEA RACEMOSA

3 L801 TREE PLANTING IN SAND-BASED STRUCTURAL SOIL

4 L801 TREE PLANTING IN PLANTING BED

2 L801 SHRUB MIX:

RED CHOKEBERRY - ARONIA ARUBUTIFOLIA
DWARF FOTHERGILLA - FOTHERGILLA GARDENII
INKBERRY - ILEX GLABRA
WINTERBERRY - ILEX VERTICILLATA
AMERICAN WITCH-HAZEL - HAMAMELIS VIRGINIANA
FRAGRANT SUMAC - RHUS AROMATICA 'GRO-LOW'
HYDRANGEA ARBORESCENS 'ANNABELLE' - 'ANNABELLE' HYDRANGEA

1 L801 TALL GRASS MIX:

SWITCHGRASS - PANICUM VIRGATUM
TUFTED HAIR GRASS - DESCHAMPSIA CESPITOSA
CANADA BLUEJOINT - CALAMAGROSTIS CANADENSIS
BUNCHED BROOM-SEDGE - ANDROPOGON VIRGINICUS

MATCHLINE SEE ####

1 PLANTING PLAN - 2
1" = 20'

2 HARBOR

329 NORTHERN AVE
BOSTON, MA 02210

OWNER
BCP-CG HARBOR PROPERTY LLC
C/O BEACON CAPITAL PARTNERS, LLC
200 STATE STREET, FIFTH FLOOR
BOSTON, MA 02109

ARCHITECT
HANDEL ARCHITECTS, LLP
69 CANAL ST. 2ND FLOOR
BOSTON, MA 02114
T: 617.651.4790

CONSULTING ARCHITECT
STUDIO ENÉE
460 HILLSIDE AVE
NEEDHAM, MA 02494
T: 781.858.3011

CONSULTING ARCHITECT
TRIA
21 DRYDOCK AVE. SUITE 330W
BOSTON, MA 02210
T: 617.530.1620

CIVIL ENGINEER
NITSCH ENGINEERING, INC.
2 CENTER PLAZA #430
BOSTON, MA 02108
T: 617.338.0063

MEP ENGINEER & CODE CONSULTANT
COSENTINI ASSOCIATES
101 FEDERAL ST #600
BOSTON, MA 02110
T: 617.748.7800

STRUCTURAL ENGINEER
DESIMONE CONSULTING ENGINEERS
31 MILK ST. SUITE 1016
BOSTON, MA 02109
T: 617.936.4492

LANDSCAPE ARCHITECT
KLOPFER MARTIN DESIGN GROUP
69 CANAL ST. 2ND FLOOR
BOSTON, MA 02114
T: 617.227.2560

ENVELOPE CONSULTANT
CBI CONSULTING, LLC
250 DORCHESTER AVE
BOSTON, MA 02127
T: 617.268.8977

GEOTECHNICAL
HALEY & ALDRICH, INC.
465 MEDFORD ST. SUITE 2200
BOSTON, MA 02129
T: 617.886.7400

NOT FOR CONSTRUCTION

NO.	DATE	ISSUANCE
1	12/20/2019	CONCEPT PRICING
2	12/15/2020	50% SCHEMATIC DESIGN
3	2/18/2021	100% SCHEMATIC DESIGN
4	4/21/2021	EARLY SITE PACKAGE

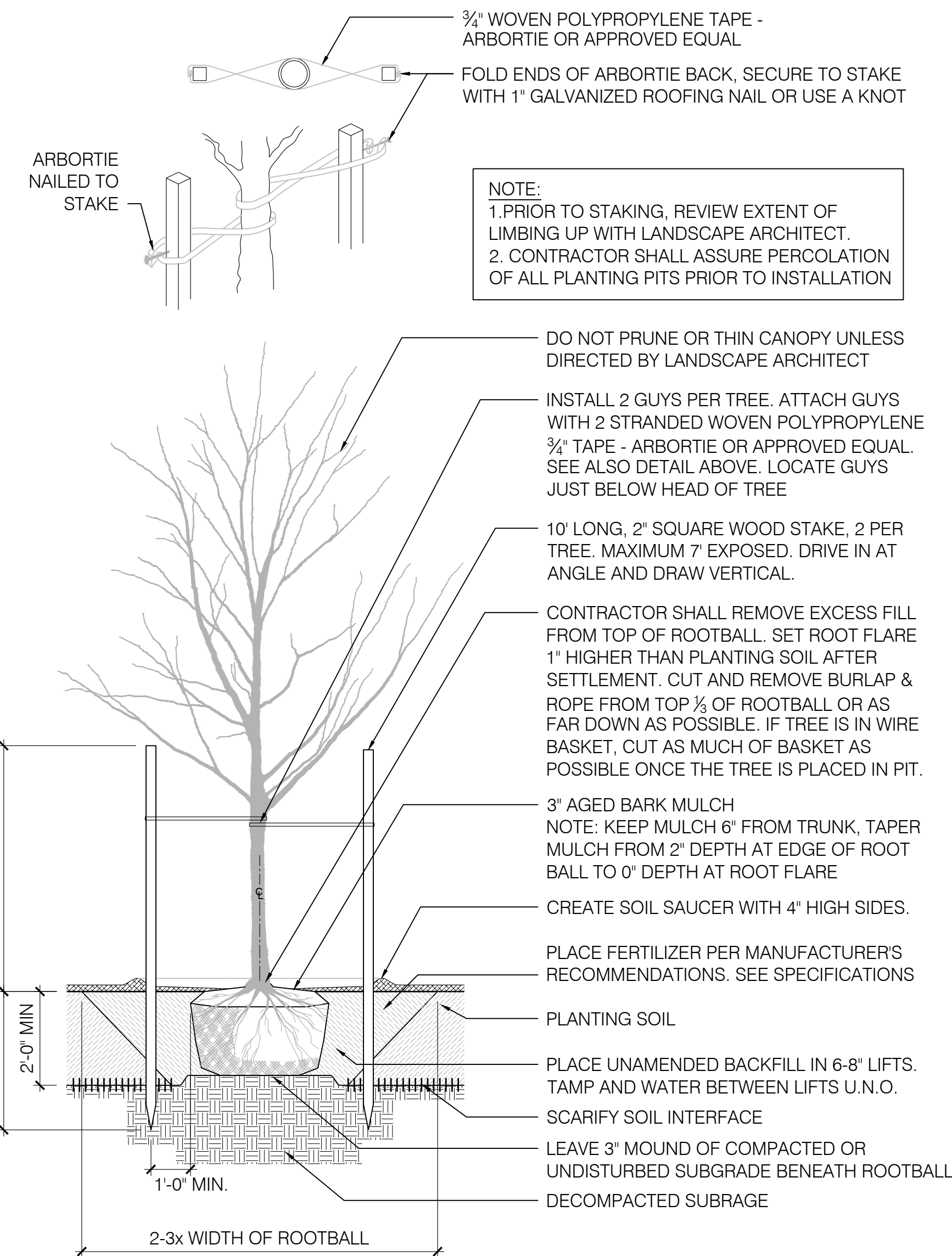

4 TREE PLANTING

SCALE: 3/8" = 1'-0"

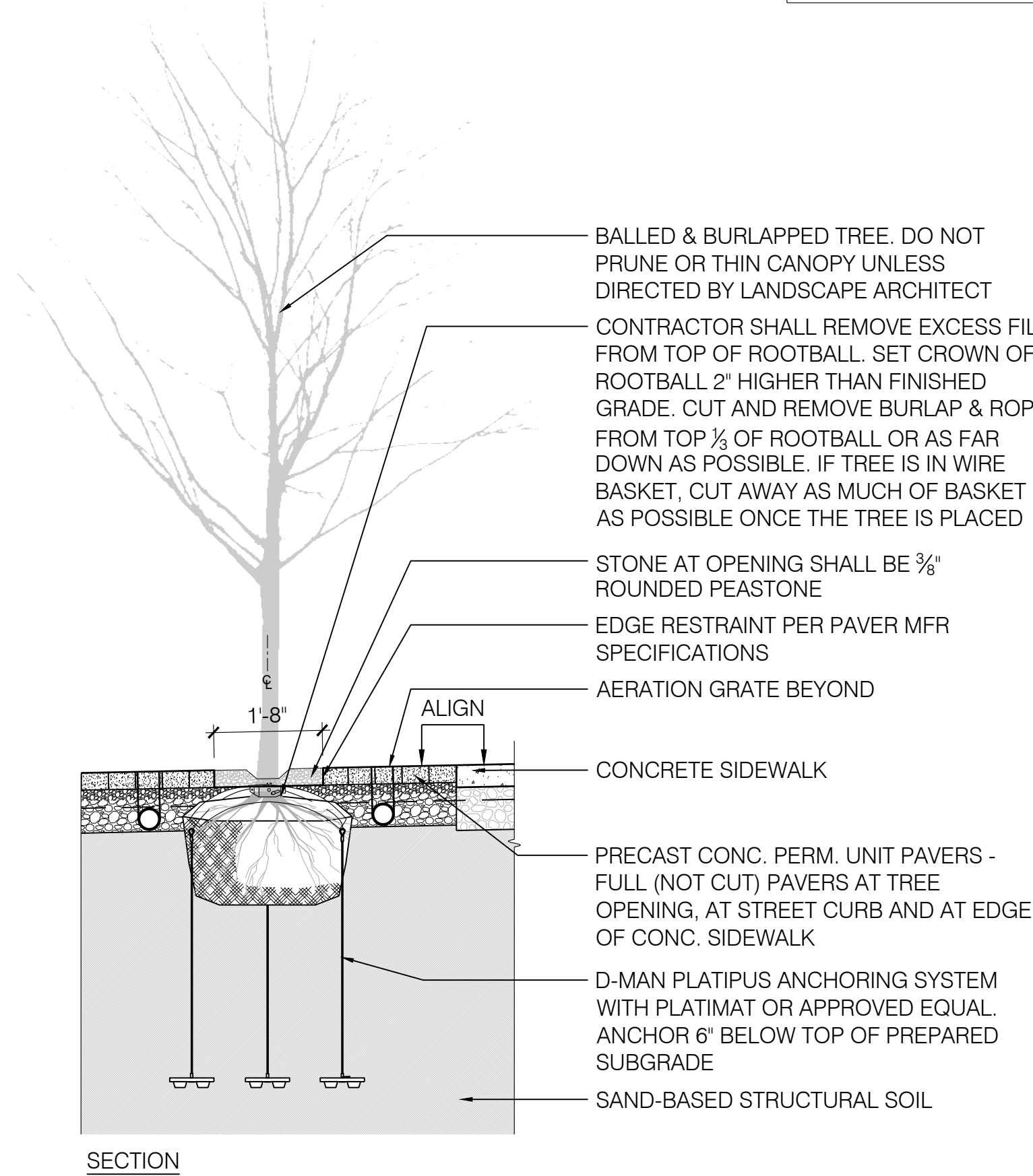
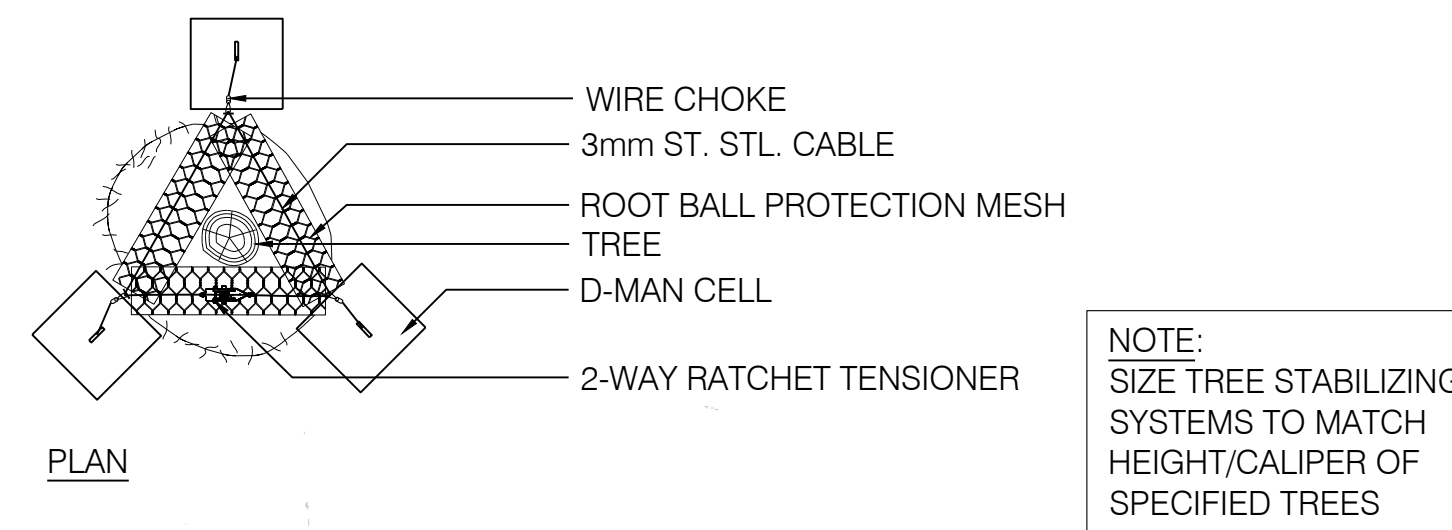

3 TREE PLANTING IN PAVEMENT

SCALE: 1/2" = 1'-0"

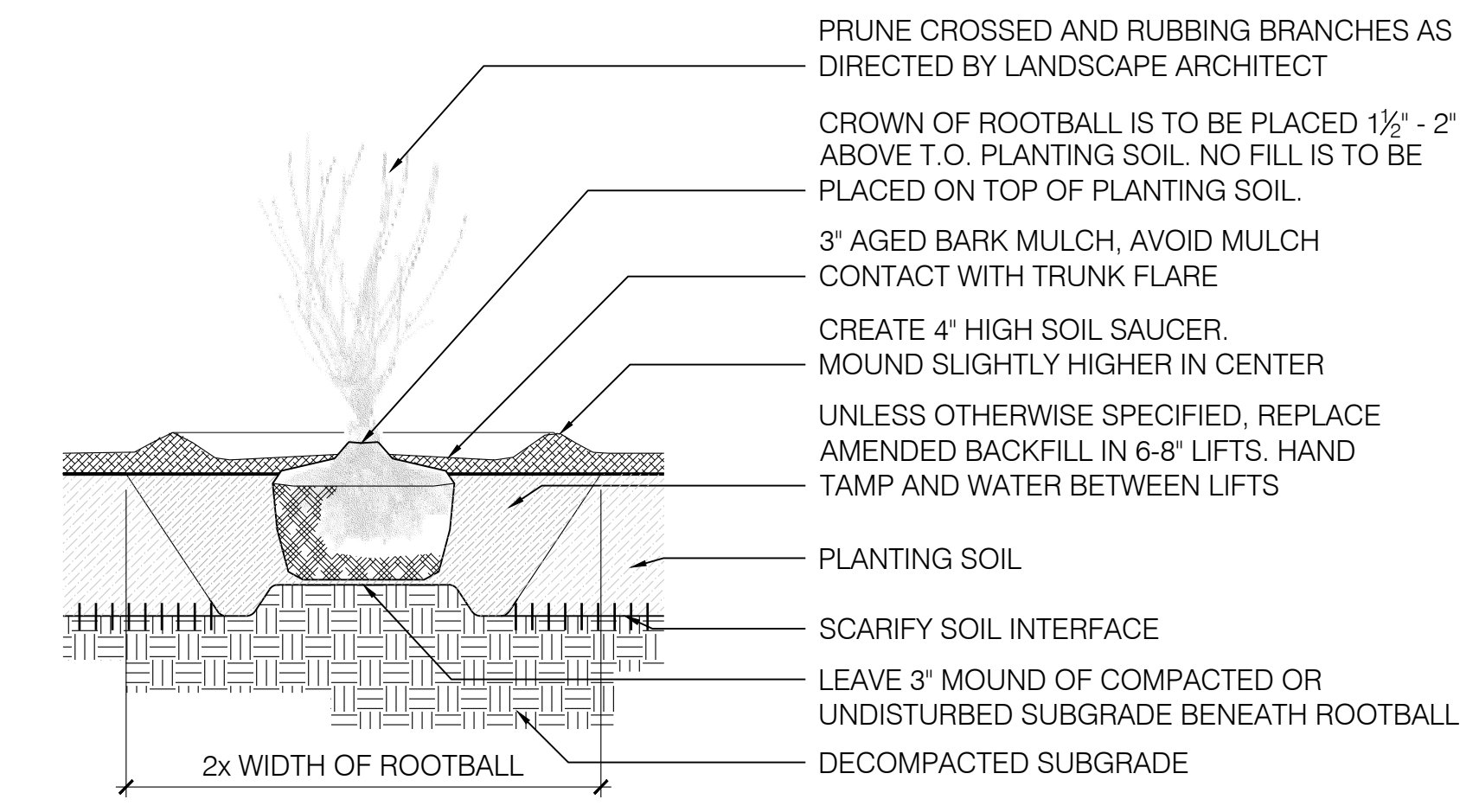

2 SHRUB PLANTING

SCALE: 3/4" = 1'-0"

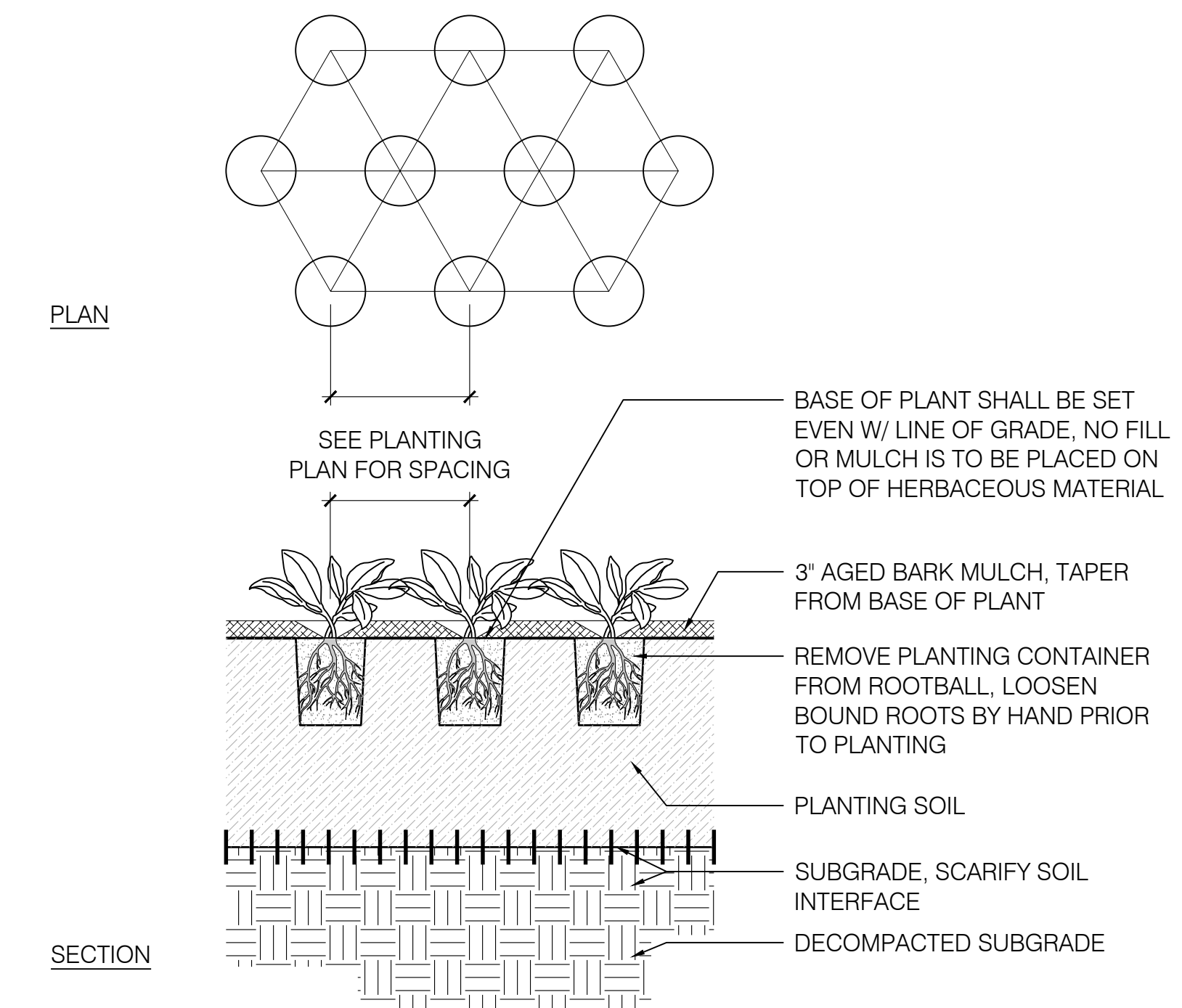

1 CONTAINER PLANTING

SCALE: 1 1/2" = 1'-0"

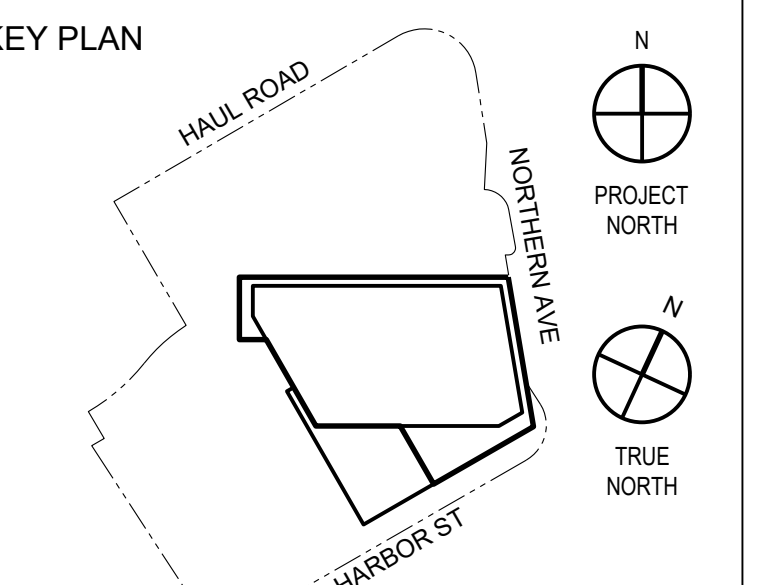

PROJECT DATUM: PROJ. 0'-0" = +16'-6" BCB
SCALE:
PROJECT NO: 1550
SEAL & SIGNATURE



DRAWING TITLE:
LANDSCAPE DETAILS - 1

DRAWING NO:

L801