

WELCOME!

Improvements to Copley Square Community Meeting 2

We will get started soon.

*This meeting is being
recorded.*

*To promote a community
feel, we'd like to see you if
you are comfortable putting
your video on! Please keep
your microphone on mute
if you are not speaking to
minimize background noise.*

Have A Question?

JOINING BY WEB (Computer, Tablet, etc):



Raise Hand

Click to raise
your hand



Q+A

Click to type
your questions



Microphone

Click to mute
or unmute

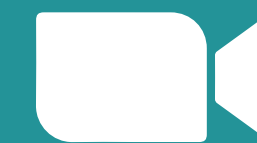

Video

Click to show
or hide your
video

JOINING BY PHONE (Dial):

Press *9 to raise your hand

Press *6 to unmute/mute yourself

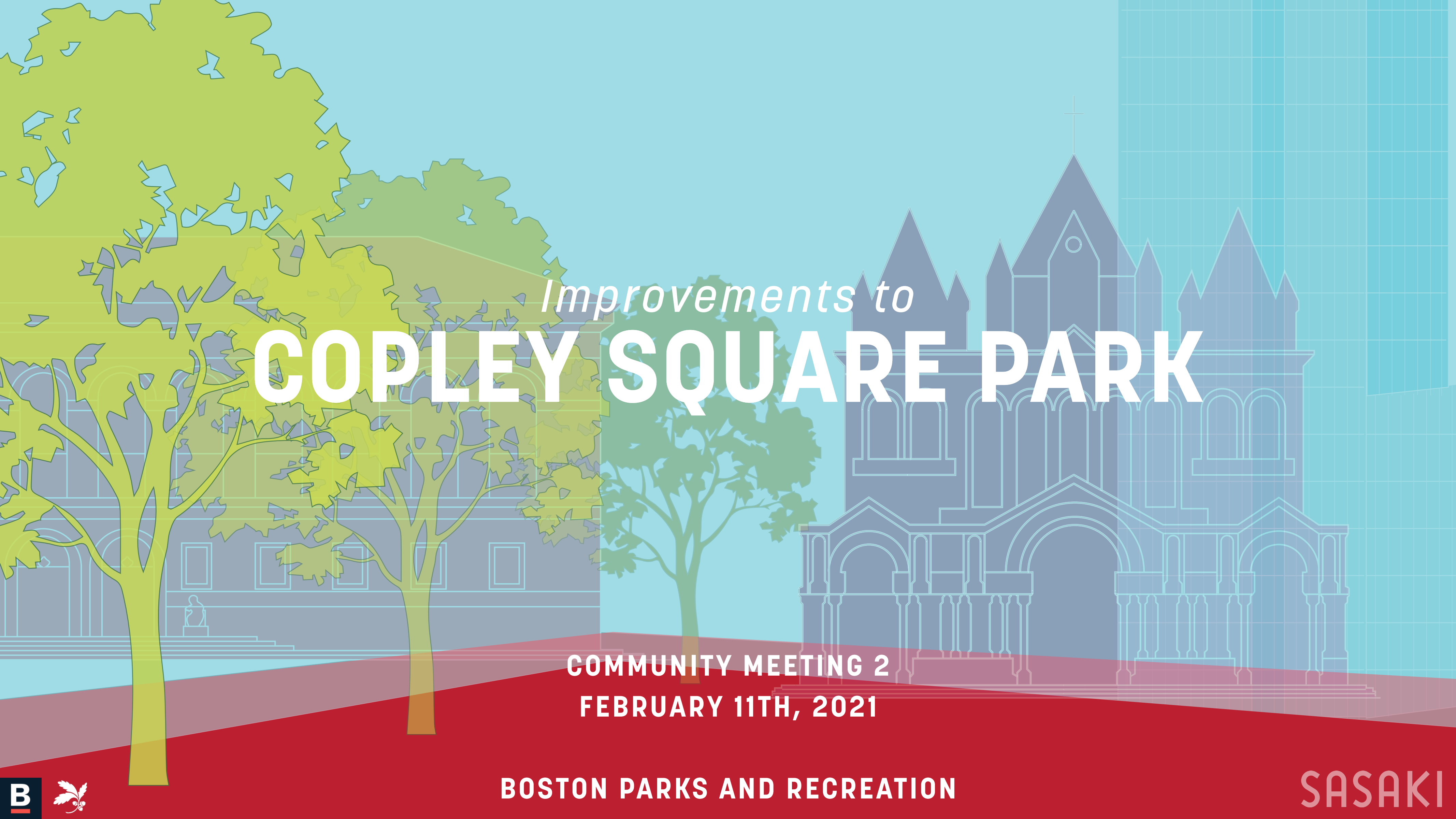

Improvements to
COPLEY SQUARE PARK

COMMUNITY MEETING 2
FEBRUARY 11TH, 2021

BOSTON PARKS AND RECREATION

SASAKI



AGENDA

Part 1: Presentation (30 minutes)

- Introduction and Process
- What We've Heard
- Opportunities and Constraints
- Conceptual Options

Part 2: Small Group Discussion (30 minutes)

Guided discussion questions with a facilitator in a zoom breakout room

Part 3: Report Out and Next Steps (20 minutes)

Introduction



Copley Square Revitalization



Project Team

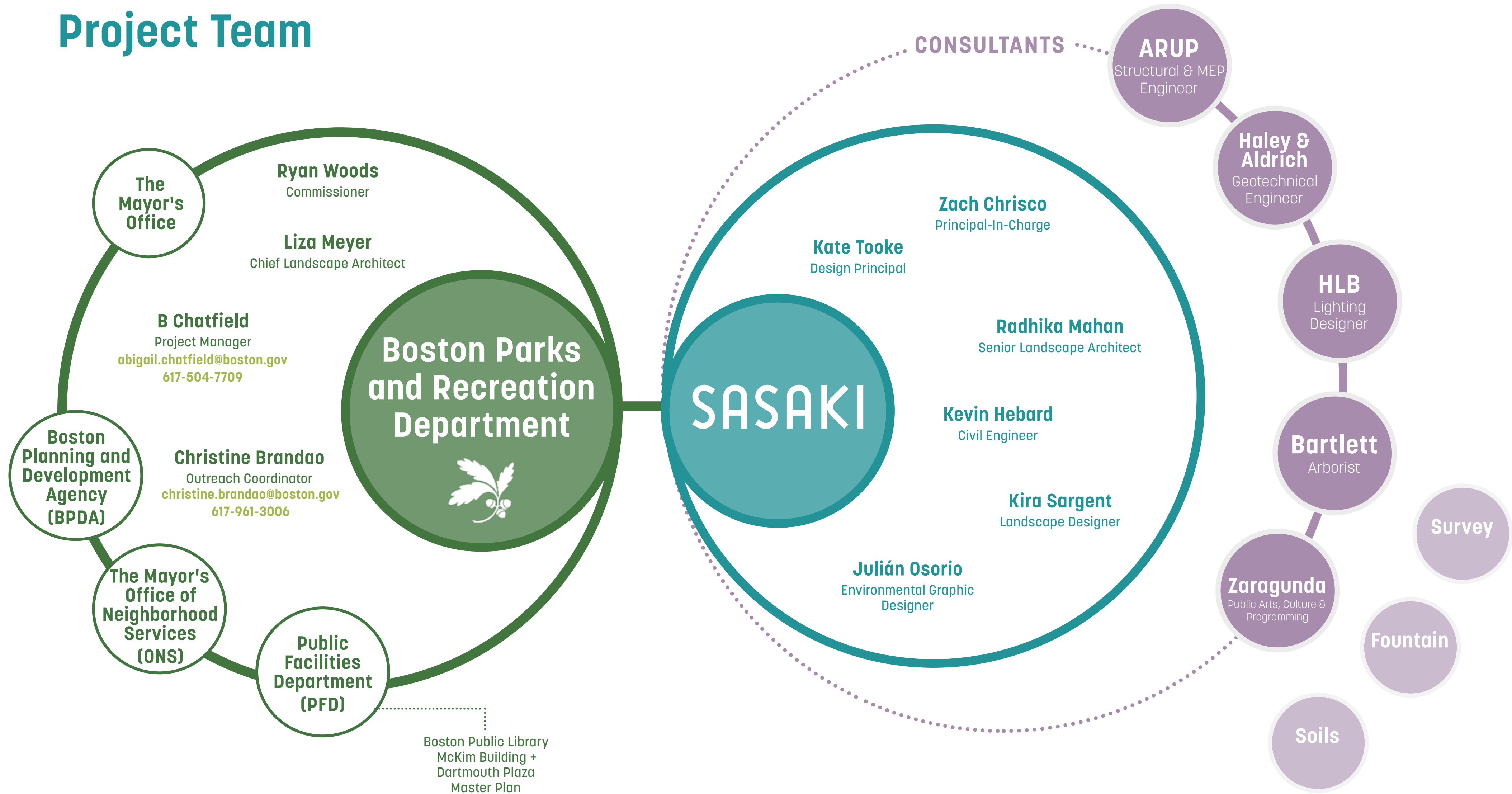

Project Schedule | The Design Process

Fall 2020 Winter 2020 Spring 2021 Summer 2021 Fall 2021

SITE ANALYSIS

- Understand the Square's past and present
- Understand community perspective and vision for the future

PROGRAM + SCHEMATIC DESIGN

Concept Options

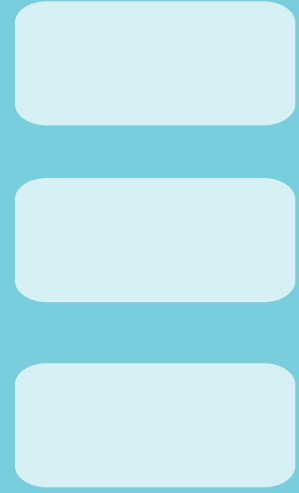

Refined Conceptual Plan

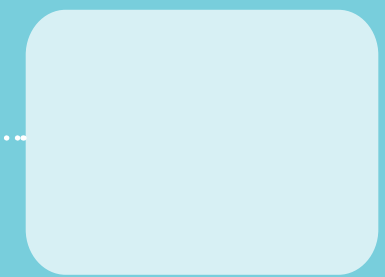

DEFINITIVE DESIGN

Design Development

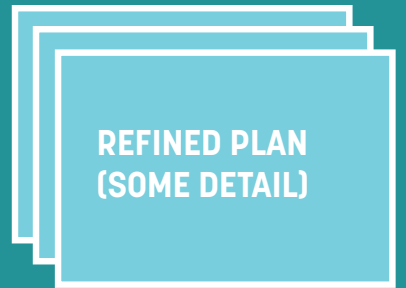

Construction Documentation



CONSTRUCTION

Estimated Budget: \$7.5M

We are here!

Public + Stakeholder Meetings

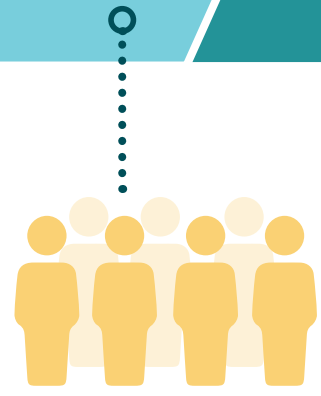
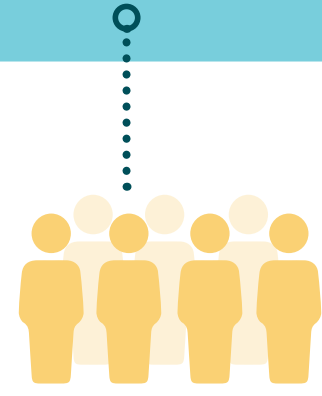
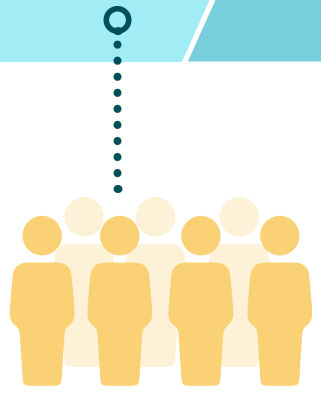

GOAL:

LISTEN

TEST CONCEPTUAL IDEAS

CONFIRM REFINED CONCEPT



WORKSHOP GOALS

The city and the design team want to hear from you.

We'll share what we've heard so far and some conceptual design ideas for the future.

We hope that you:

- ▶ Learn more about what the community values about the Square
- ▶ Express your thoughts on what works in each design scheme, and what would need improvement
- ▶ Share your excitement about the future of Copley Square with others who might want to express their opinions

What we heard



Many Community Touchpoints...



1,244

Online Survey Responses

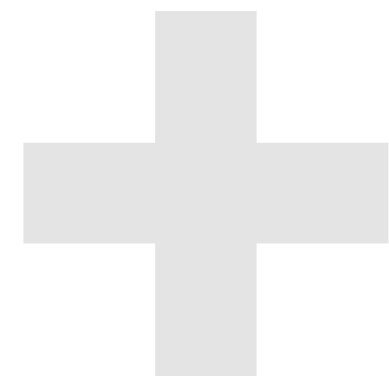

16

Steering Committee Members

12

Meetings with Parks Staff

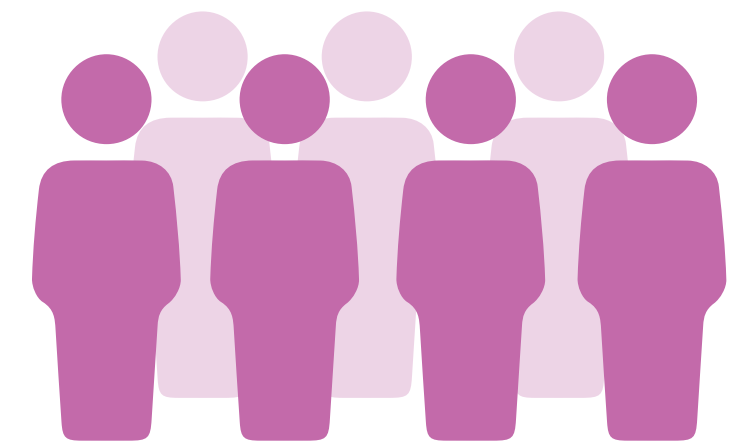

85

Attendance at Public Forum

A Diversity of Contributing Voices...

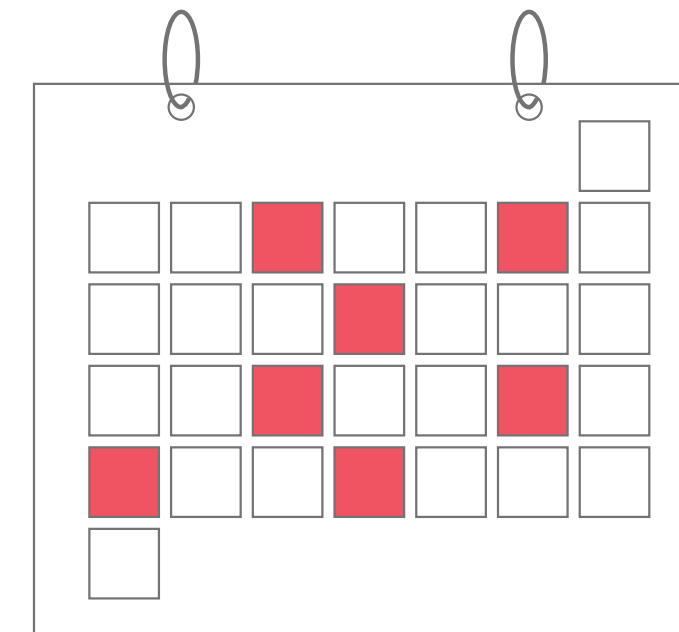
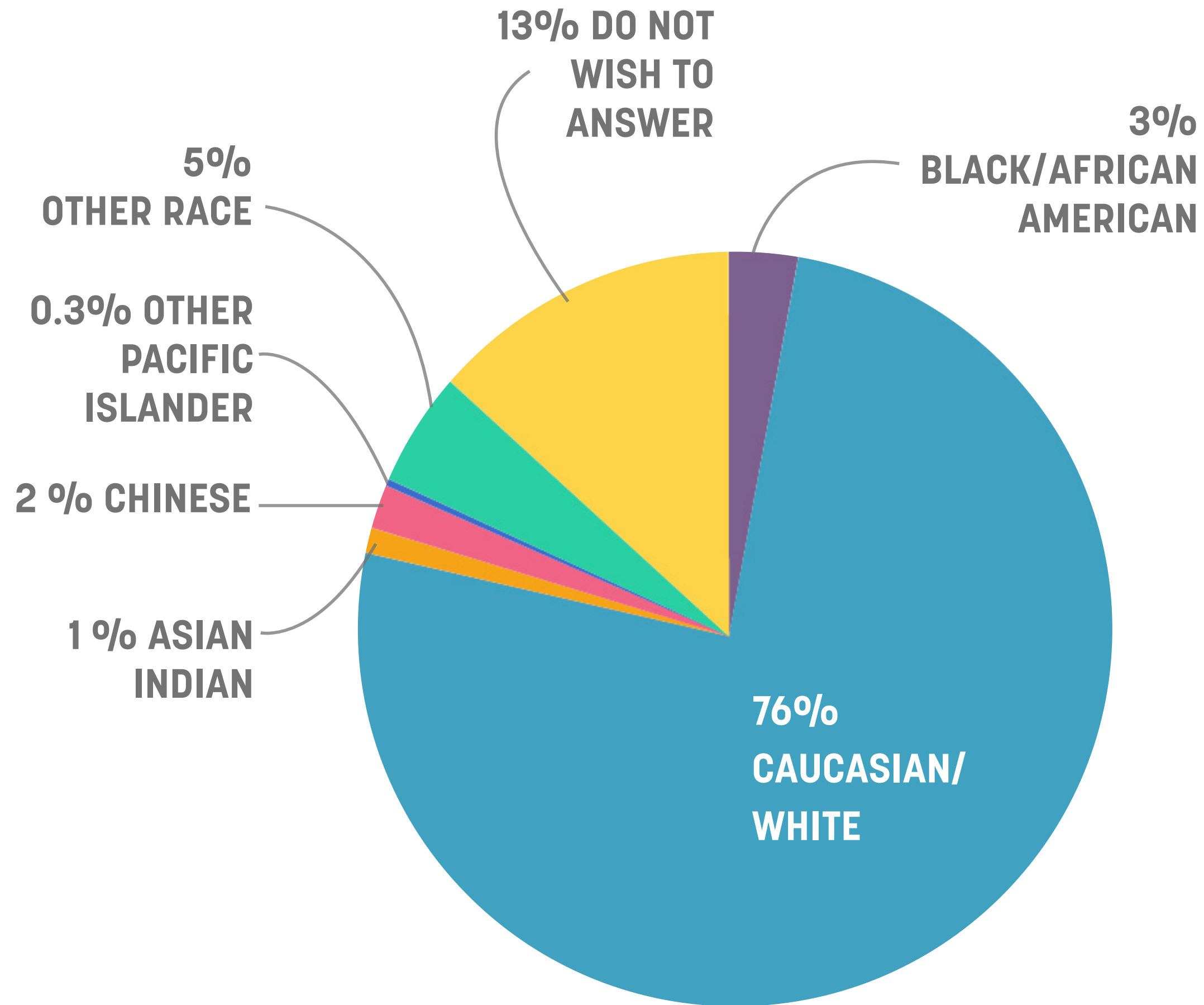

54%
**VISIT DAILY
OR WEEKLY**

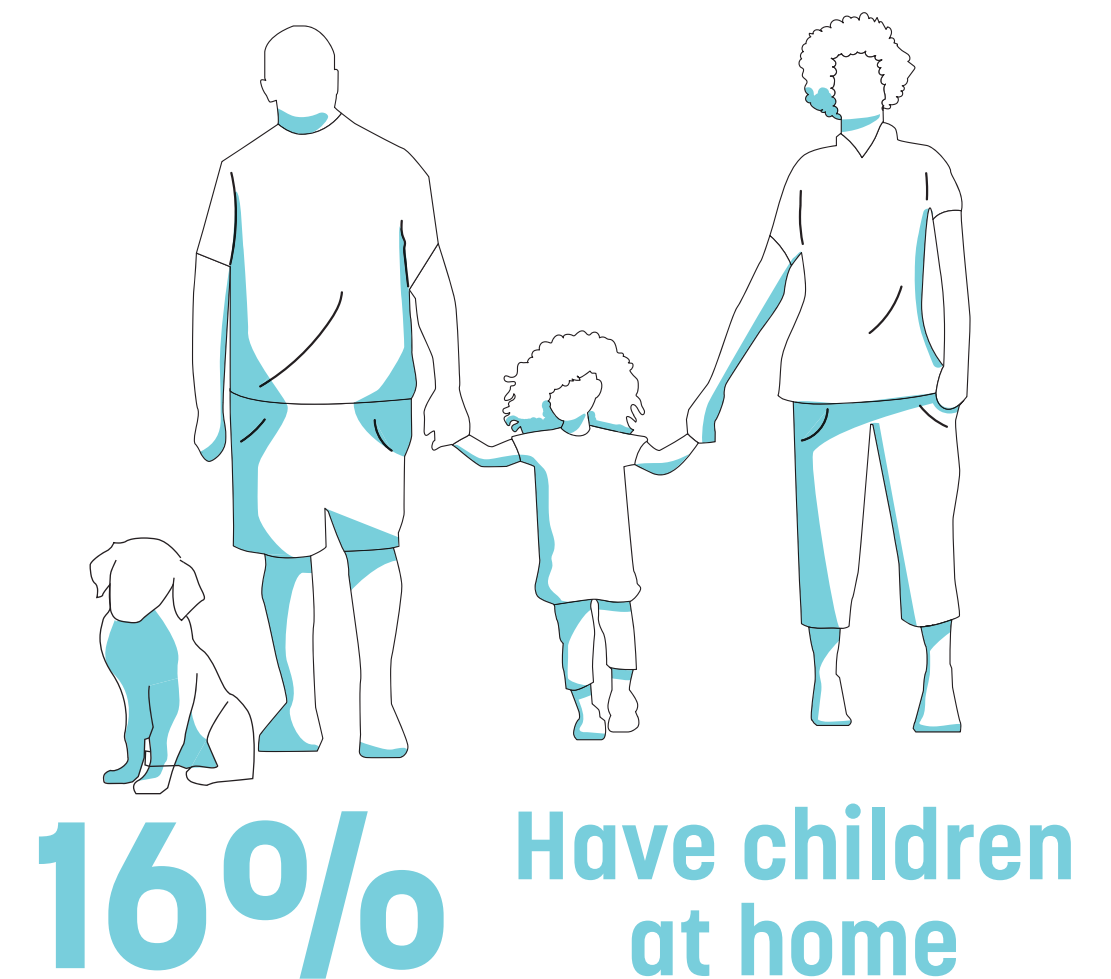

Identifying with Many User Groups...

*Respondents could choose up to 3 user groups

Top four groups users identified with...

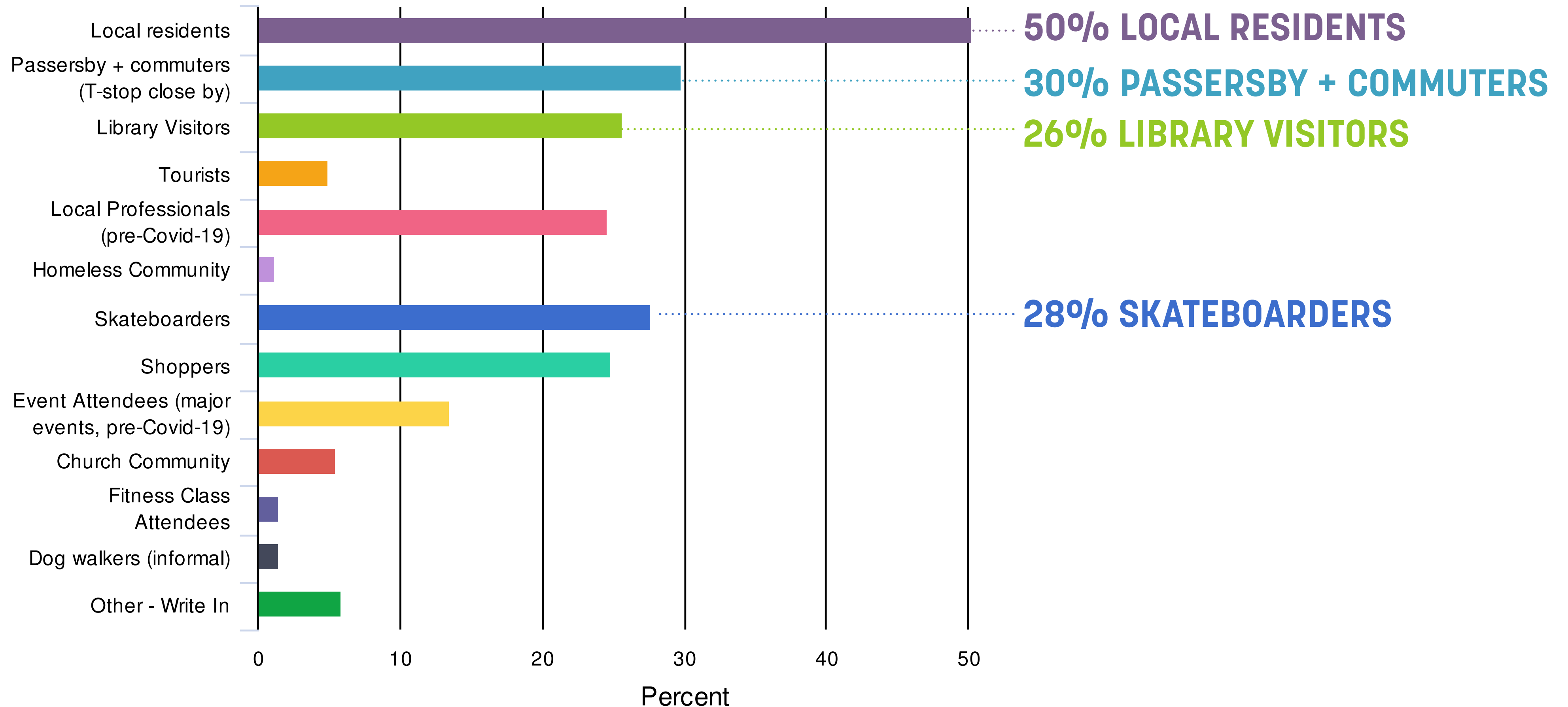

Representing the City and Beyond...

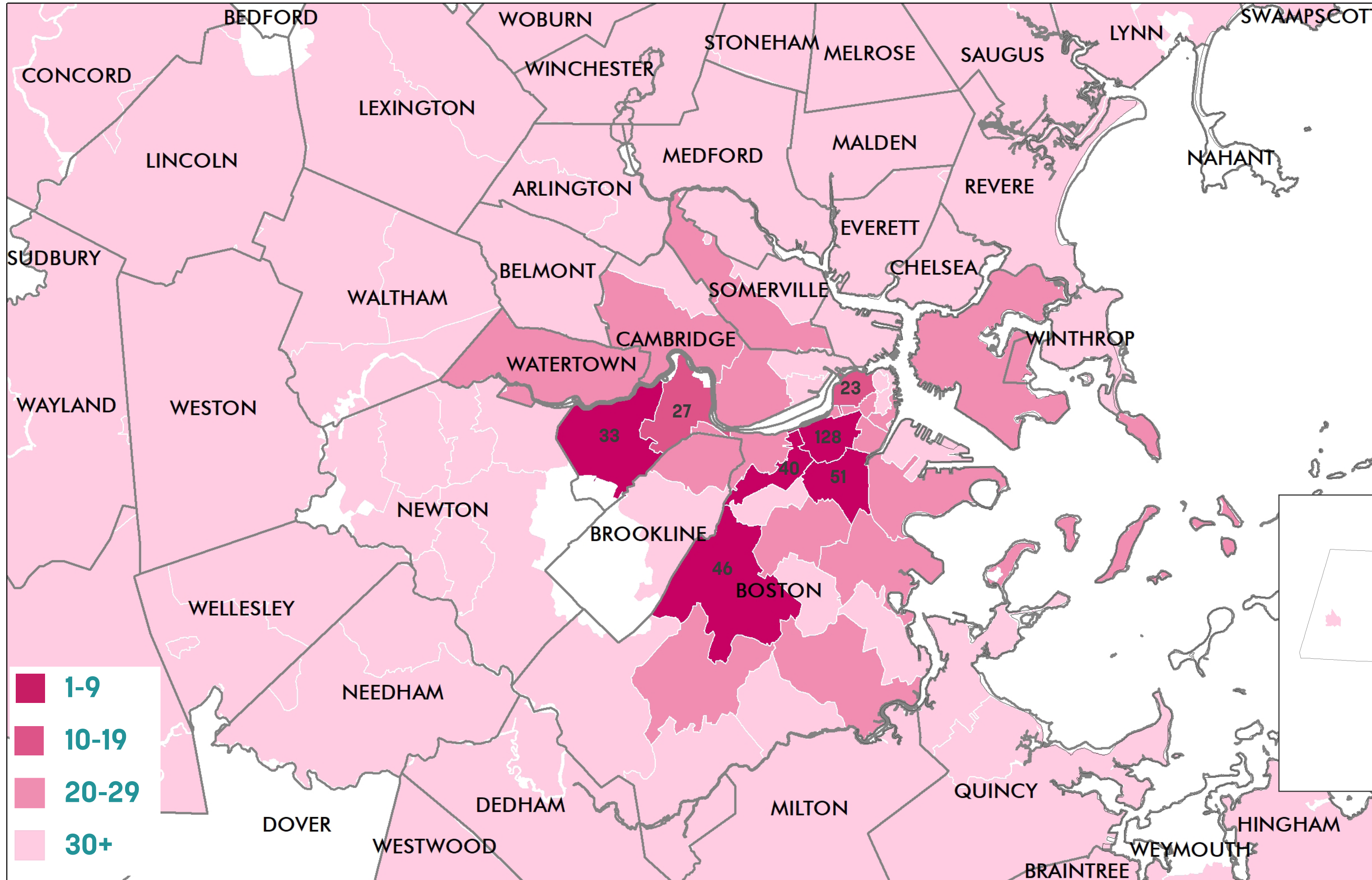

BASED ON ZIP
CODES PROVIDED BY
RESPONDENTS

59%

BOSTON RESIDENTS

97%

MASS RESIDENTS

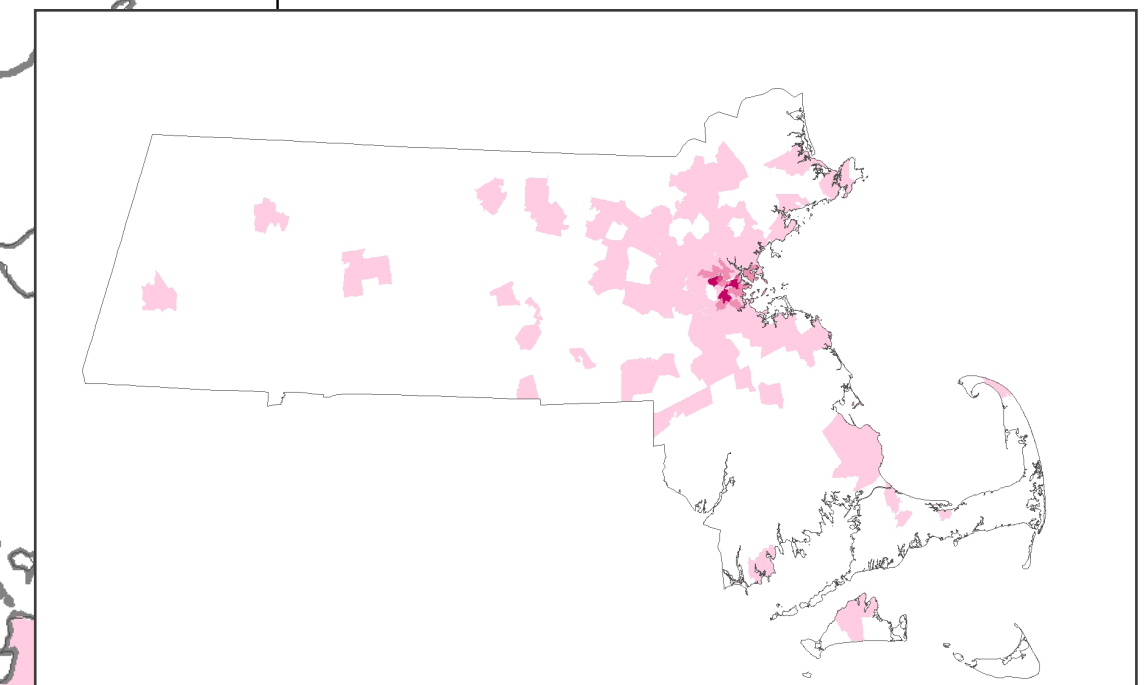

Many Things to Many Respondents

OPEN AIR MARKET

"I love the farmer's market and think it would be great to have a rotation of vendors on a weekly basis."

SKATEBOARDING SPOT

"Copley Square has been a beacon for skateboarding in Boston for decades."

LUNCH HANGOUT

"Great place to bring your lunch and relax and be entertained by skateboarders"

RELAXING PARK

"It is wonderful to have a place where one can go to relax (walk, sit) amid the hustle and bustle of the city"

HISTORIC ICON

"The beauty of the Square is in the harmony of historic architecture"



CHARACTER

Keep the existing balance of paved space to green space

Balance modern amenities and styles with historic charm of Back Bay

Celebrate the surrounding historic and iconic architecture

Key Takeaways

Be flexible for future event and activation types and styles

Improve accommodations for large annual or weekly events like the Marathon, First Night and the Farmer's Market

Provide comfortable and social spaces for daily activation

PROGRAM

PEOPLE

Balance needs of diverse constituent groups

Universal access

A landscape that feels welcoming to all

Showcase sustainability through materials and strategies

Sustain + enhance the existing tree canopy

Prioritize ease of maintenance, inspiring stewardship

ENVIRONMENT

**An Iconic Landmark at
the Heart of Back Bay**

**An Inclusive Bostonian
Gathering Place**

CHARACTER

PEOPLE

**CORNERSTONES OF
A SUCCESSFUL
COPLEY SQUARE**

Project Guiding Principles

PROGRAM

ENVIRONMENT

**A Vibrant Destination
within the Hub**

**A Durable and
Sustainable New
England Landscape**

NOTE: More detail on the project guiding principles, including detailed goals, can be found on the project website.

Opportunities & Constraints



Copley Square Today

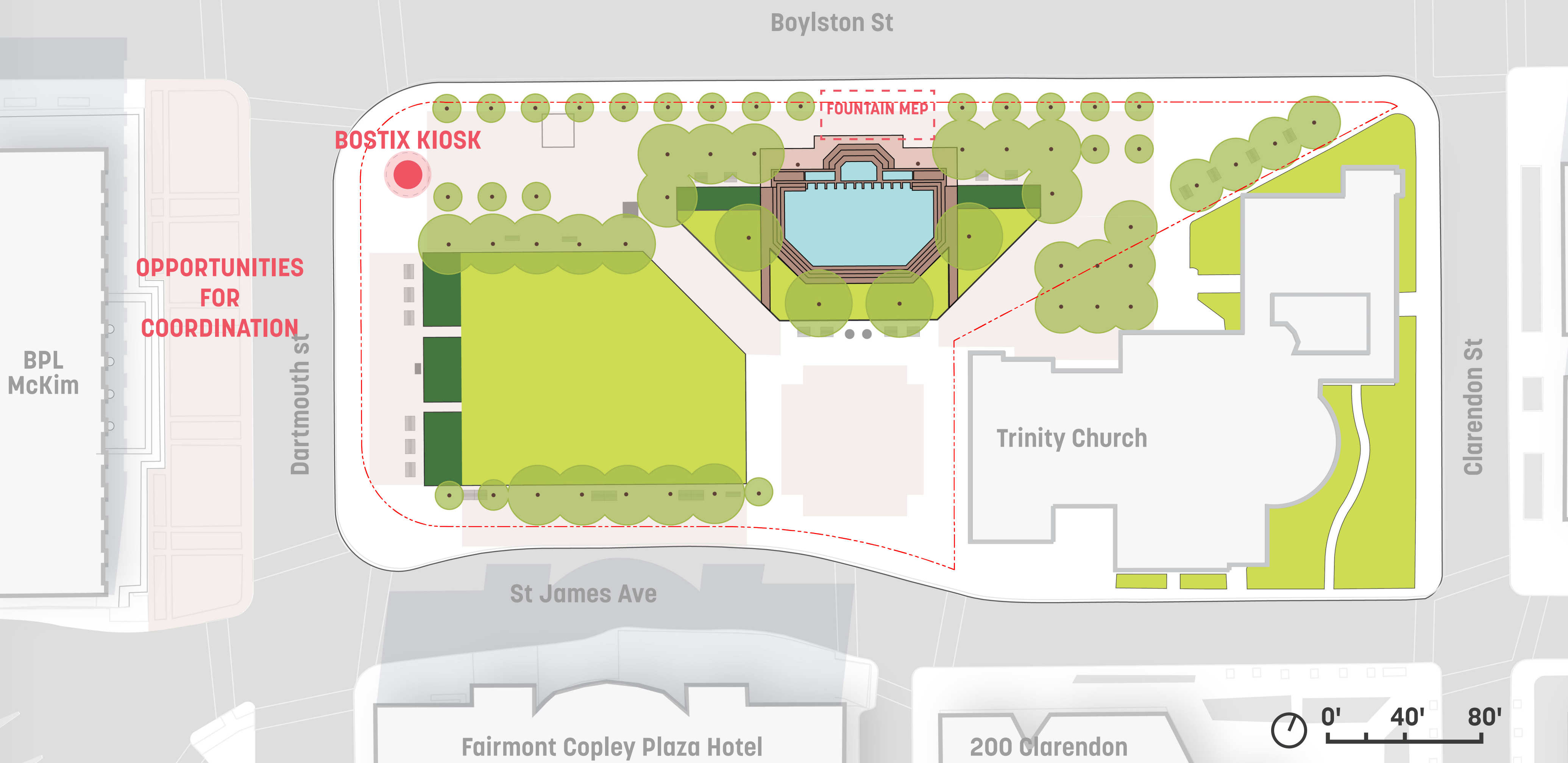

Tree Suitability for Preservation

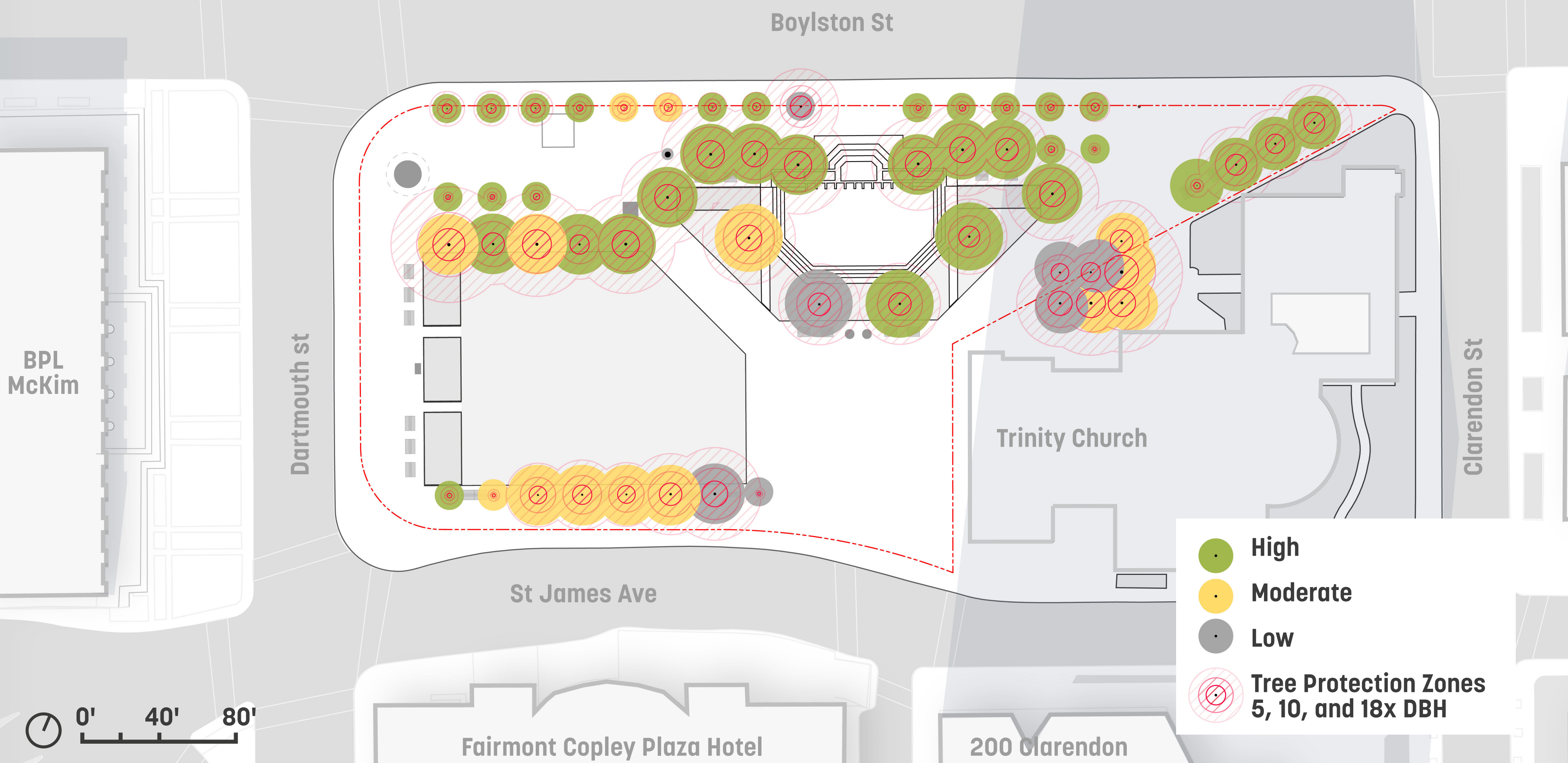

Boylston St

BPL
McKim

Dartmouth st





Clarendon St

Trinity Church

St James Ave

Fairmont Copley Plaza Hotel

200 Clarendon

-  High
-  Moderate
-  Low
-  Tree Protection Zones
5, 10, and 18x DBH

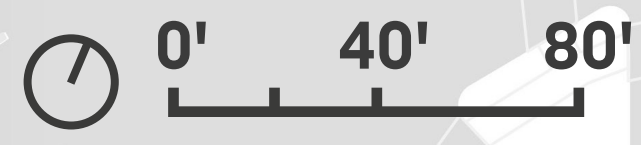

Tree Stewardship Strategies

EXISTING CONDITIONS

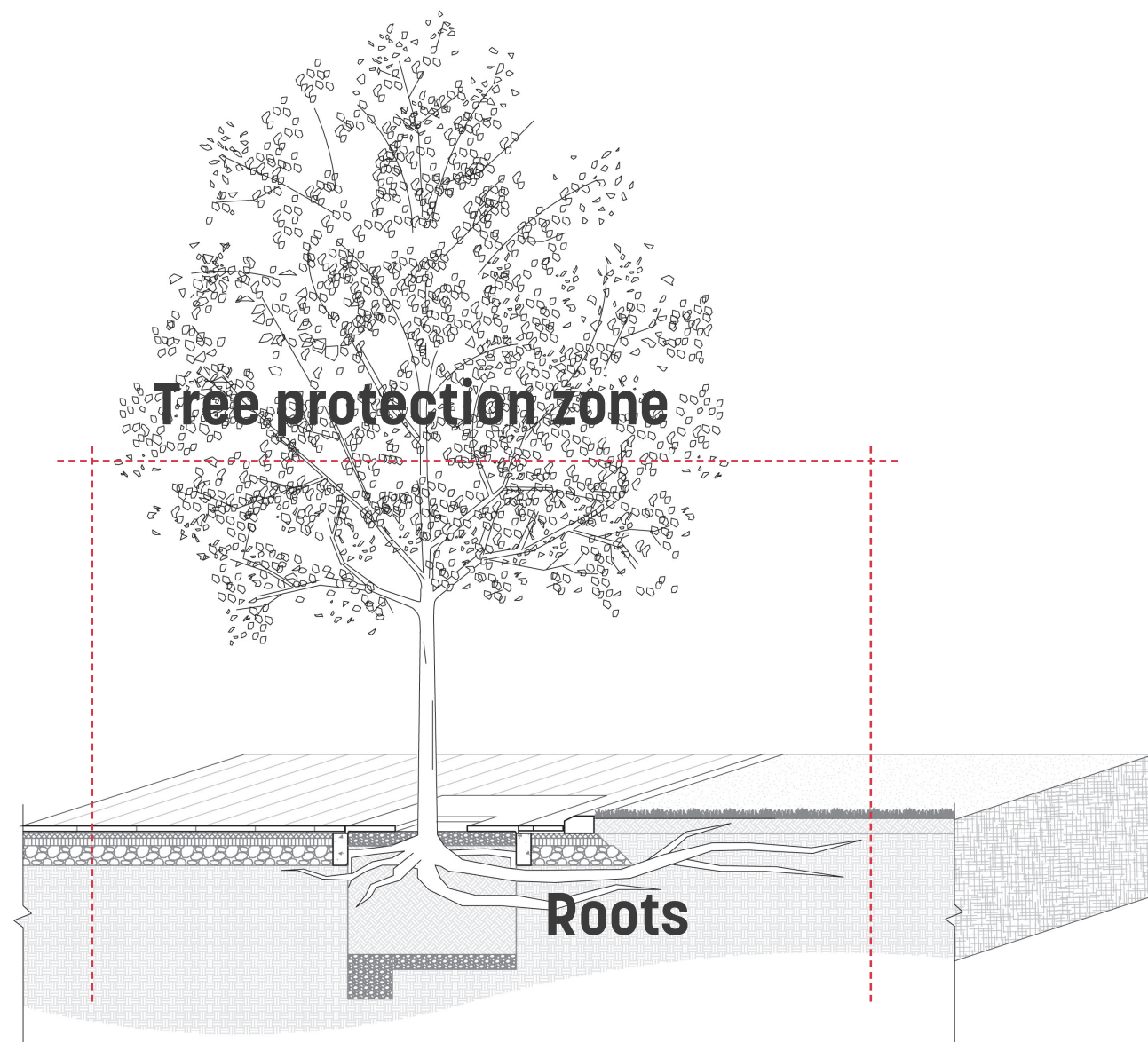

PLANTING BED

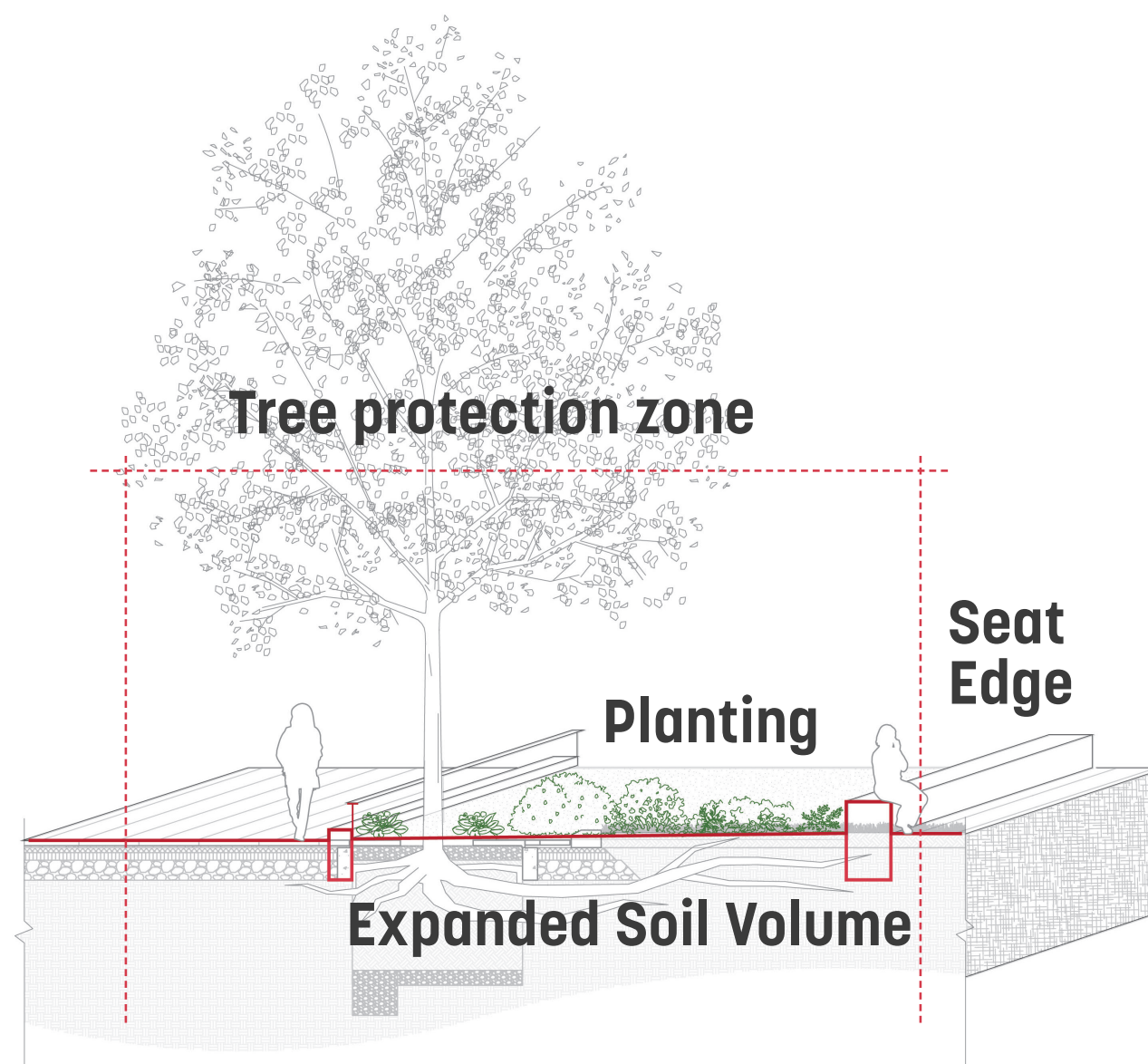

ELEVATED WALK

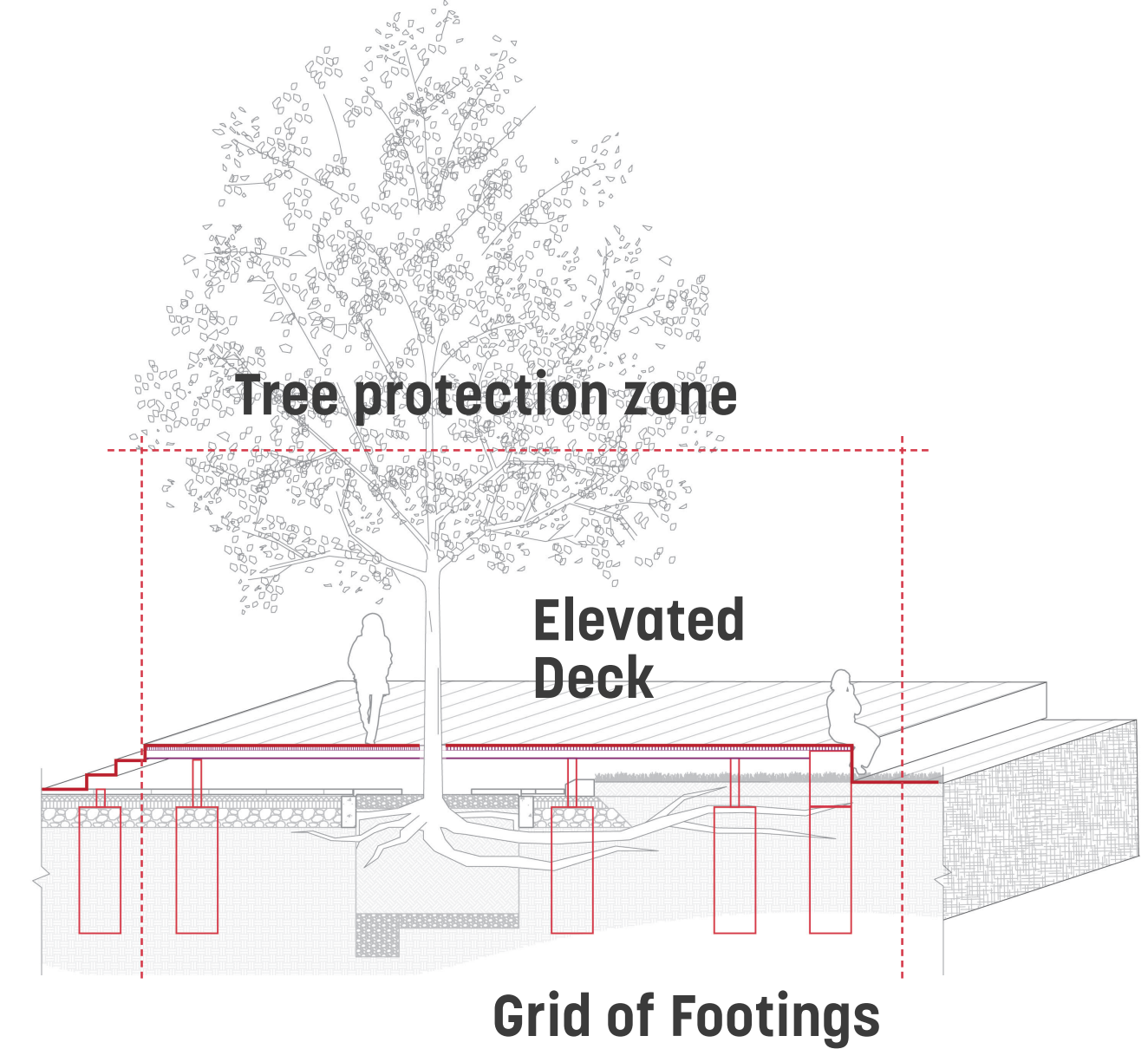

Stormwater Strategies

Existing Conditions

Hard surfaces prevent groundwater recharge, negatively impacting existing wood piles.

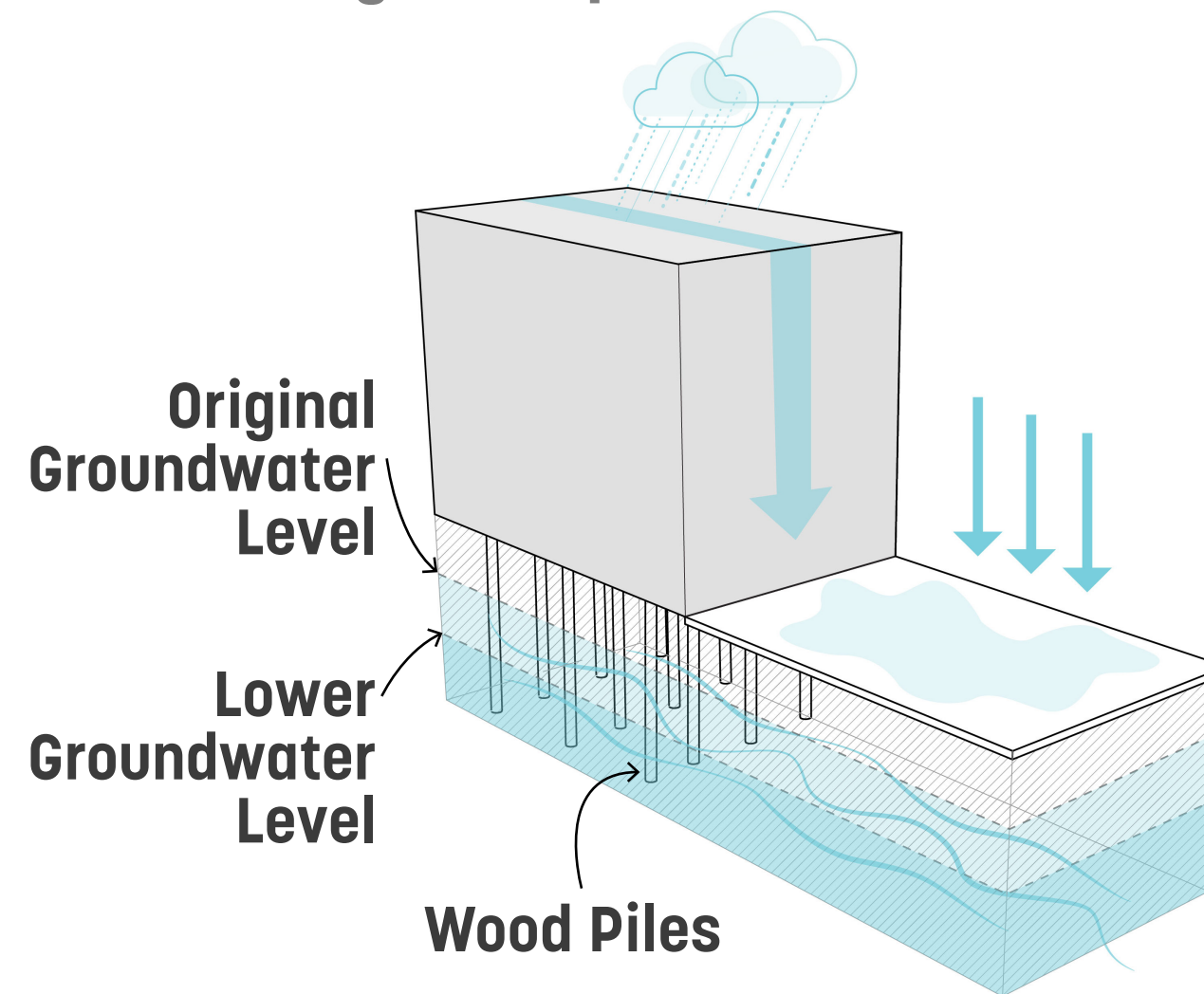

Groundwater Recharge Options

UNDERGROUND STORAGE

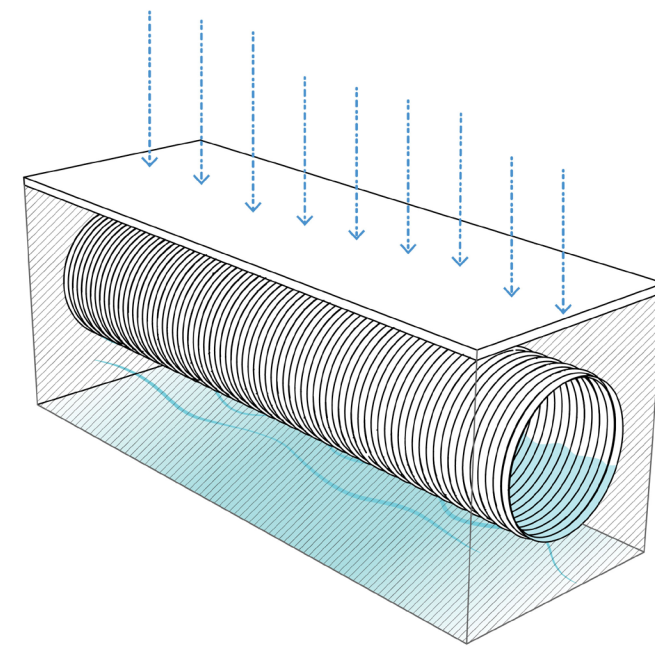

PERMEABLE PAVEMENT

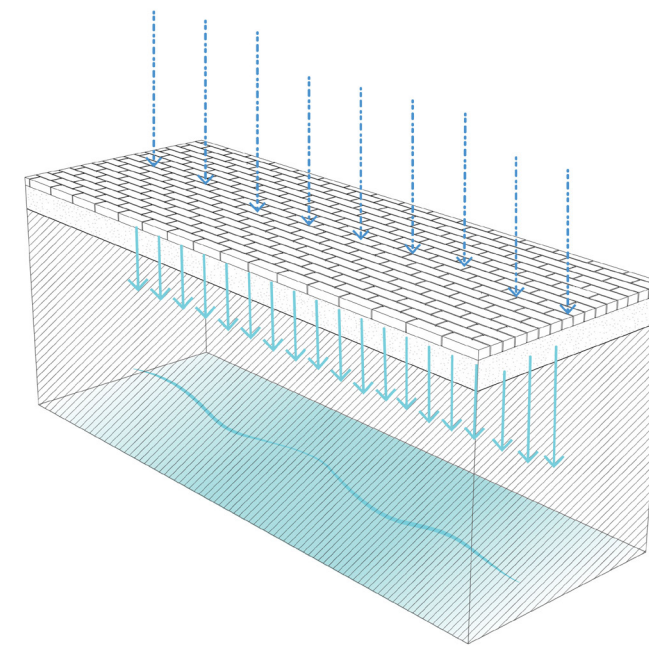

PLANTING AREAS

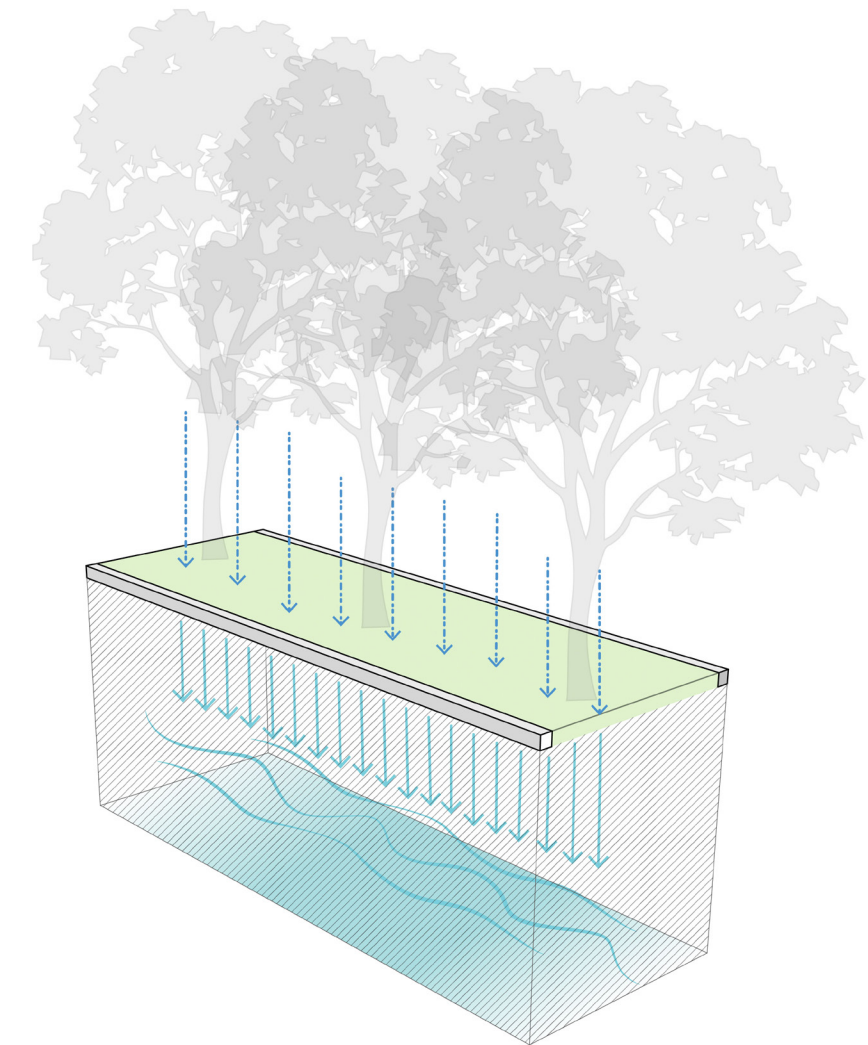

Conceptual Options





City Platform



**Raised
Crossings**



**Framed
Ellipse**



City Platform

A signature stage for civic life extends under Copley's legacy tree canopy, connecting lawn, plaza and fountain.

City Platform Plan



Boylston St

Dartmouth st

Clarendon St

St James Ave

BPL
McKim

CITY PLATFORM

FOUNTAIN

BOSQUE

PLAZA

LAWN

Trinity Church

Fairmont Copley Plaza Hotel

200 Clarendon





COMFORTABLE EDGES



+

PROSPECT AND
REFUGE



+

METAL GRATING

City Platform Character

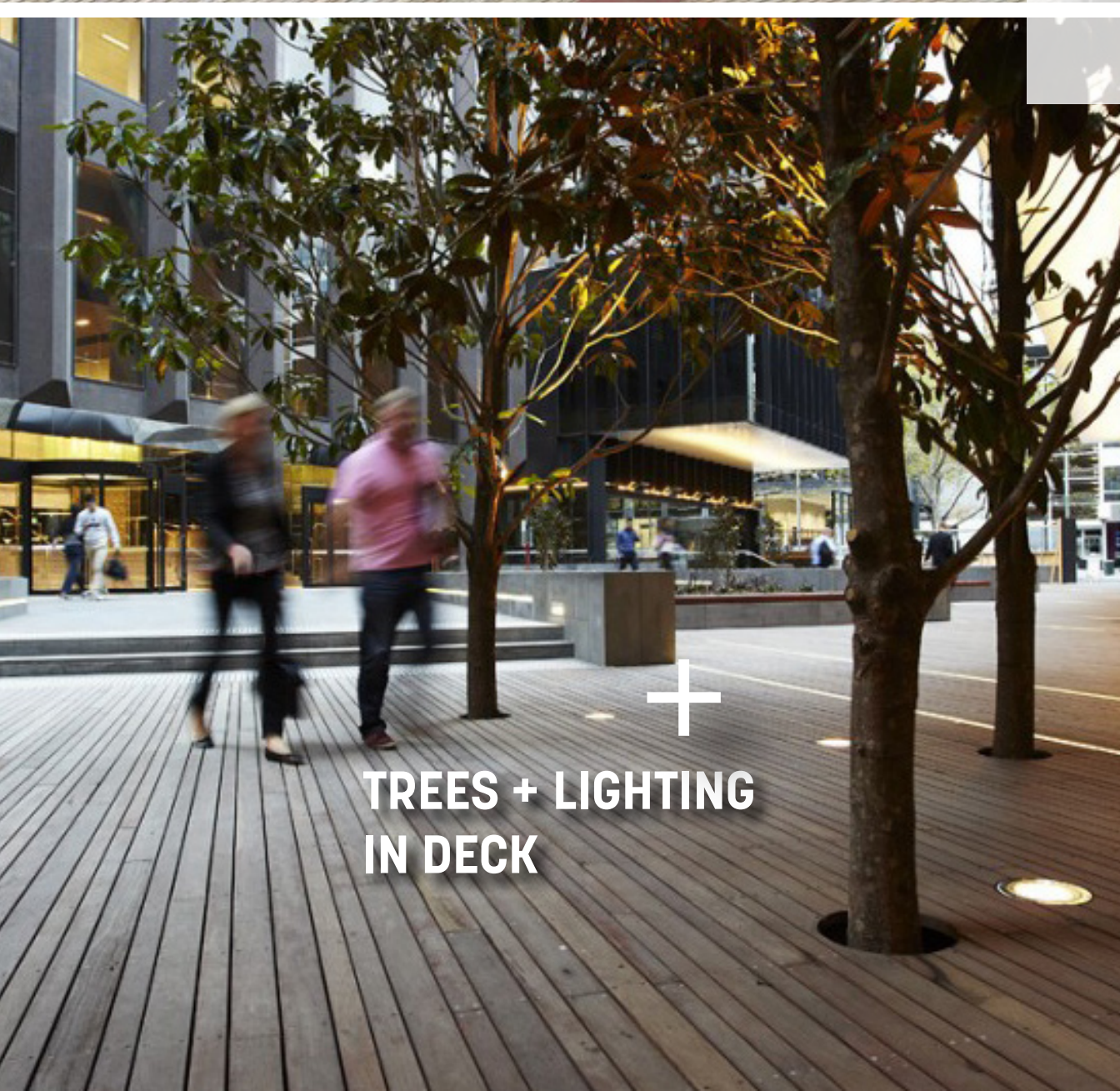

+

TREES + LIGHTING
IN DECK

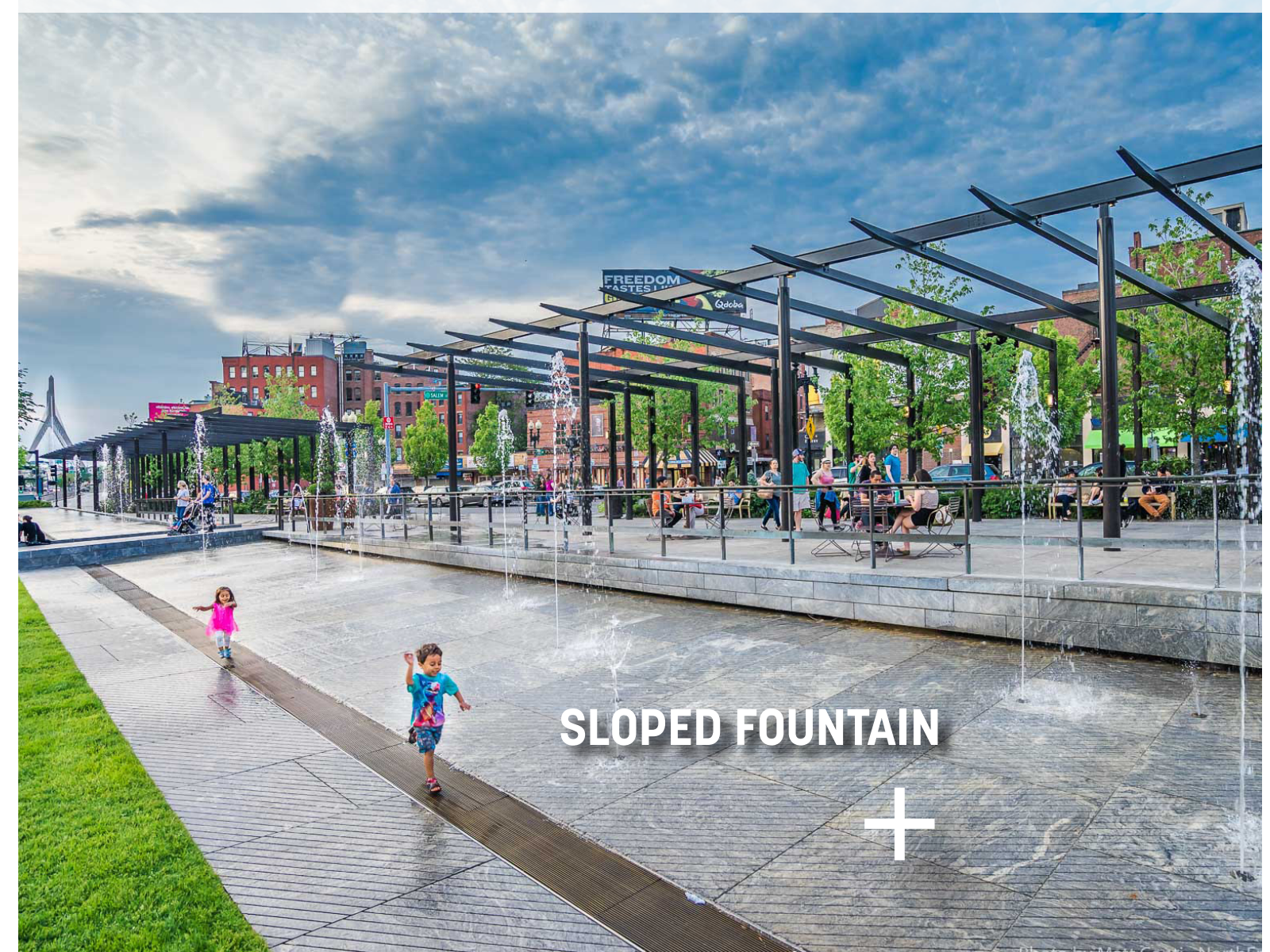

SLOPED FOUNTAIN



FLEXIBLE
FURNISHINGS



City Platform - A Flexible Edge

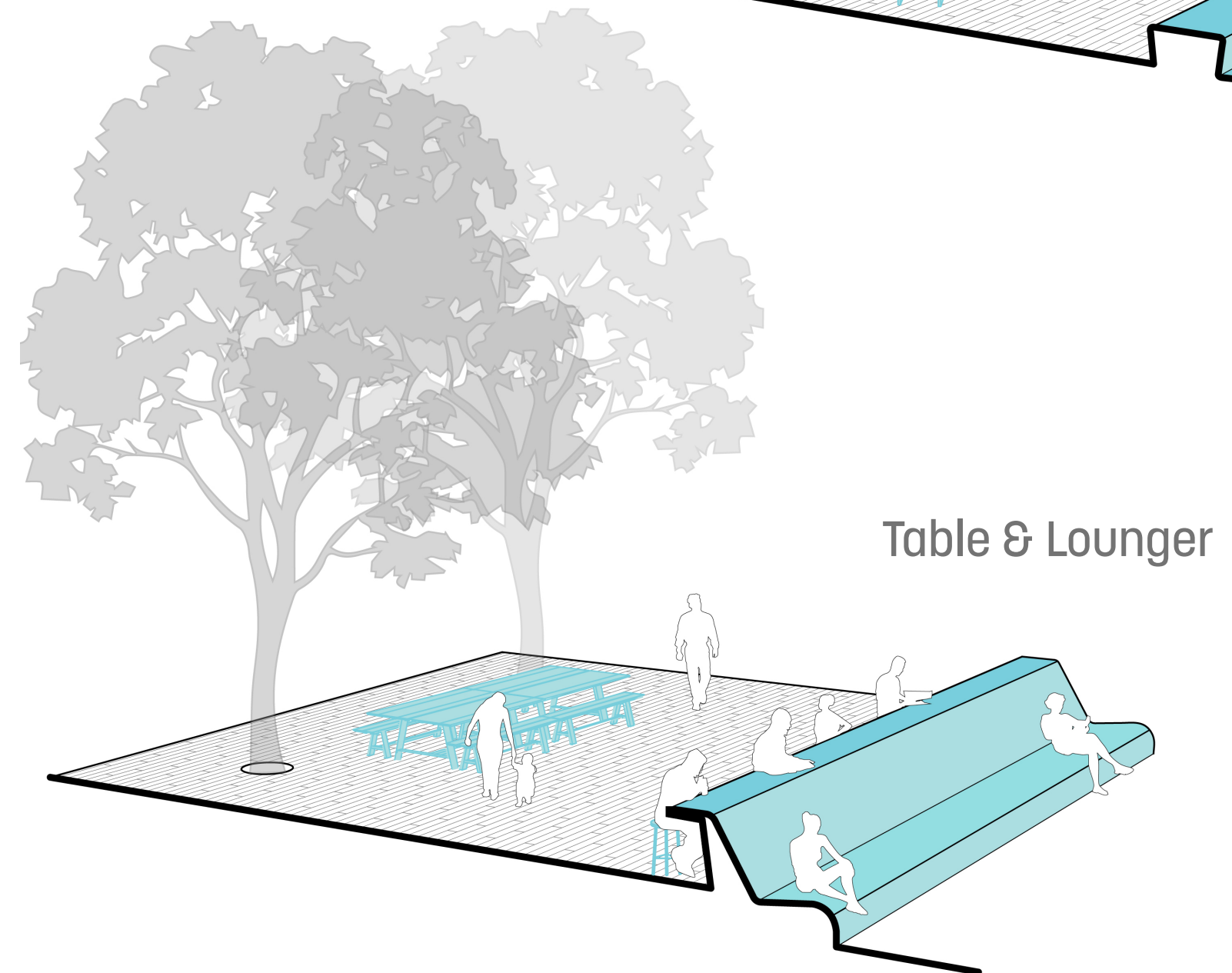
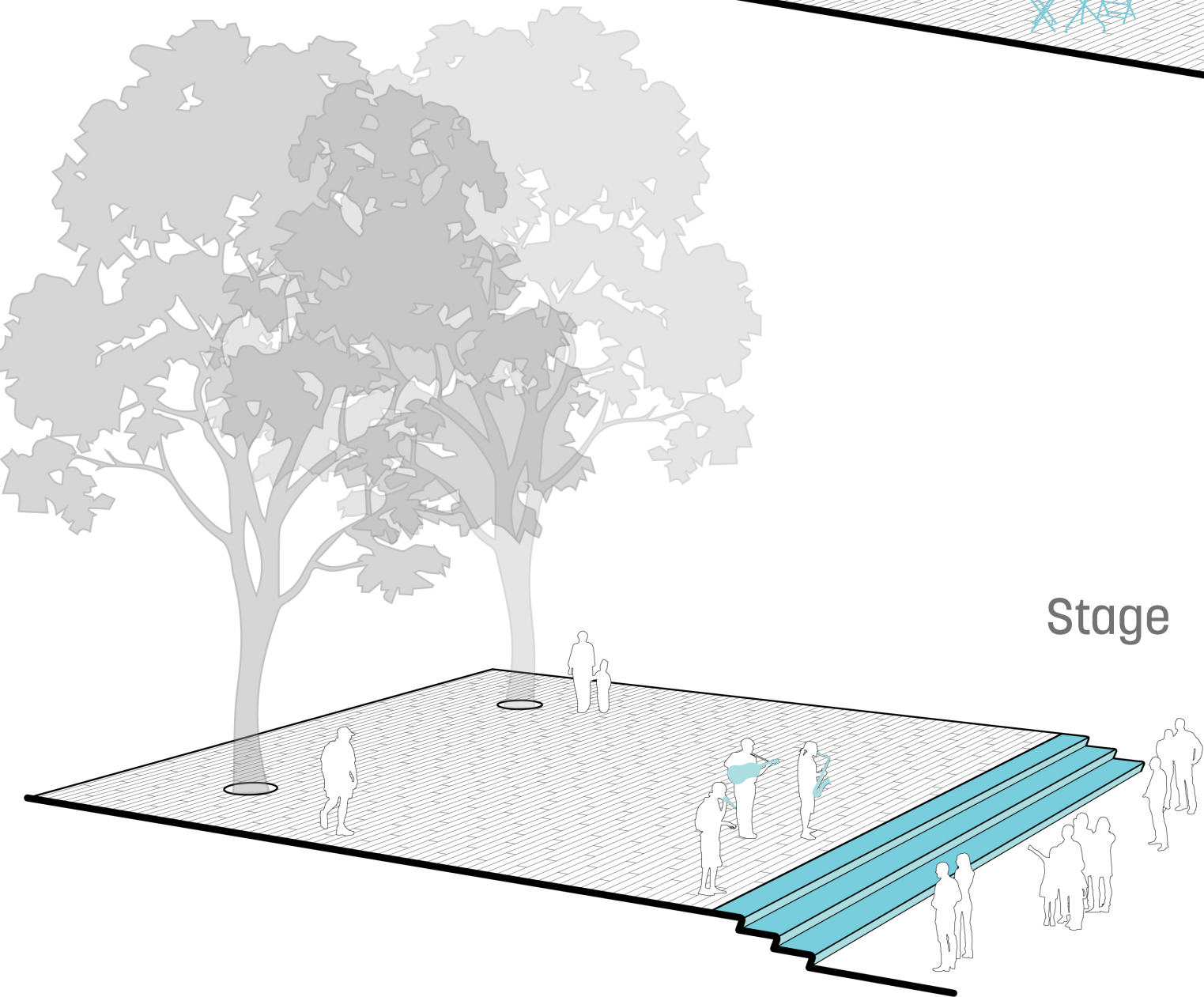
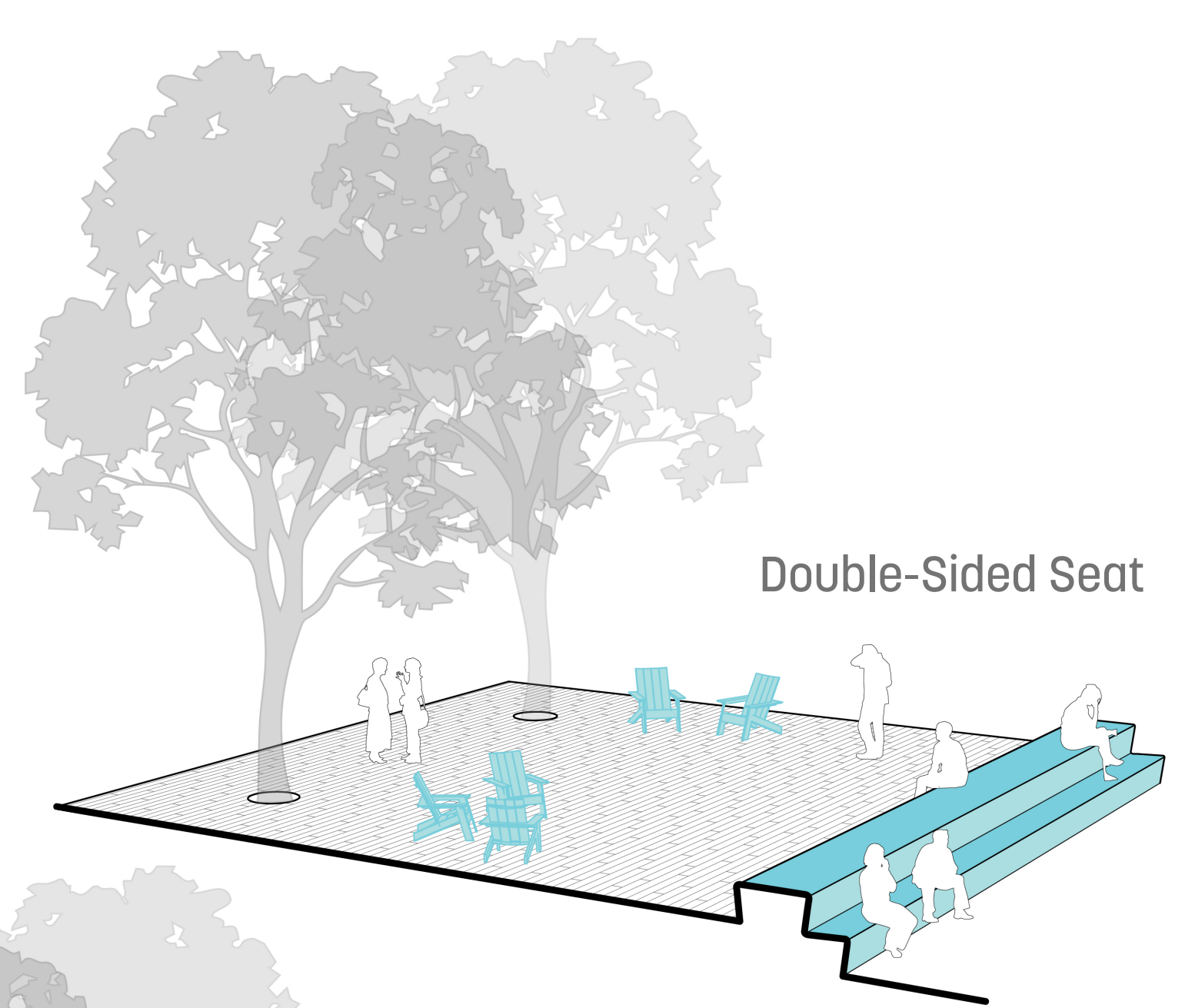
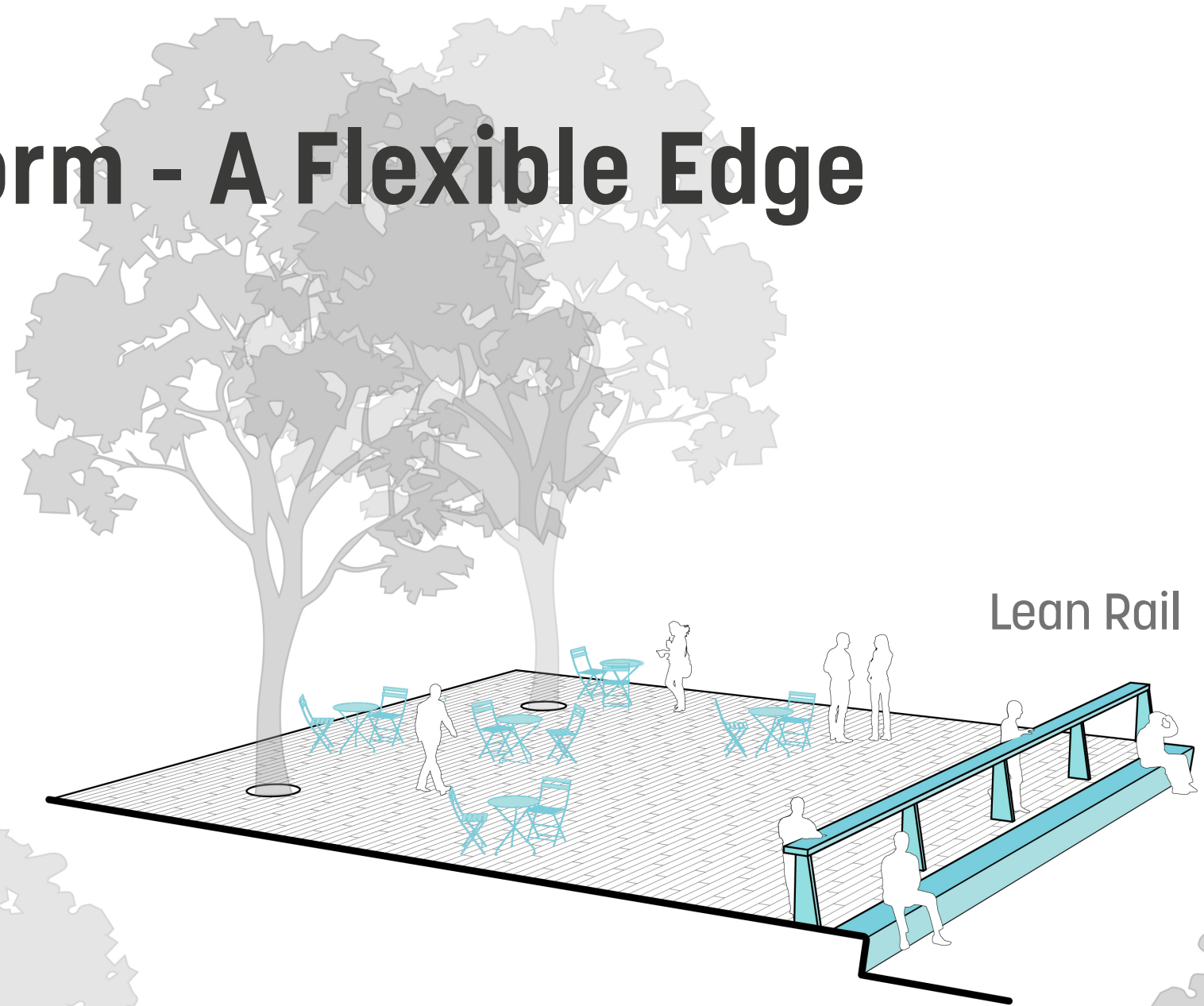

City Platform - Weekly Use

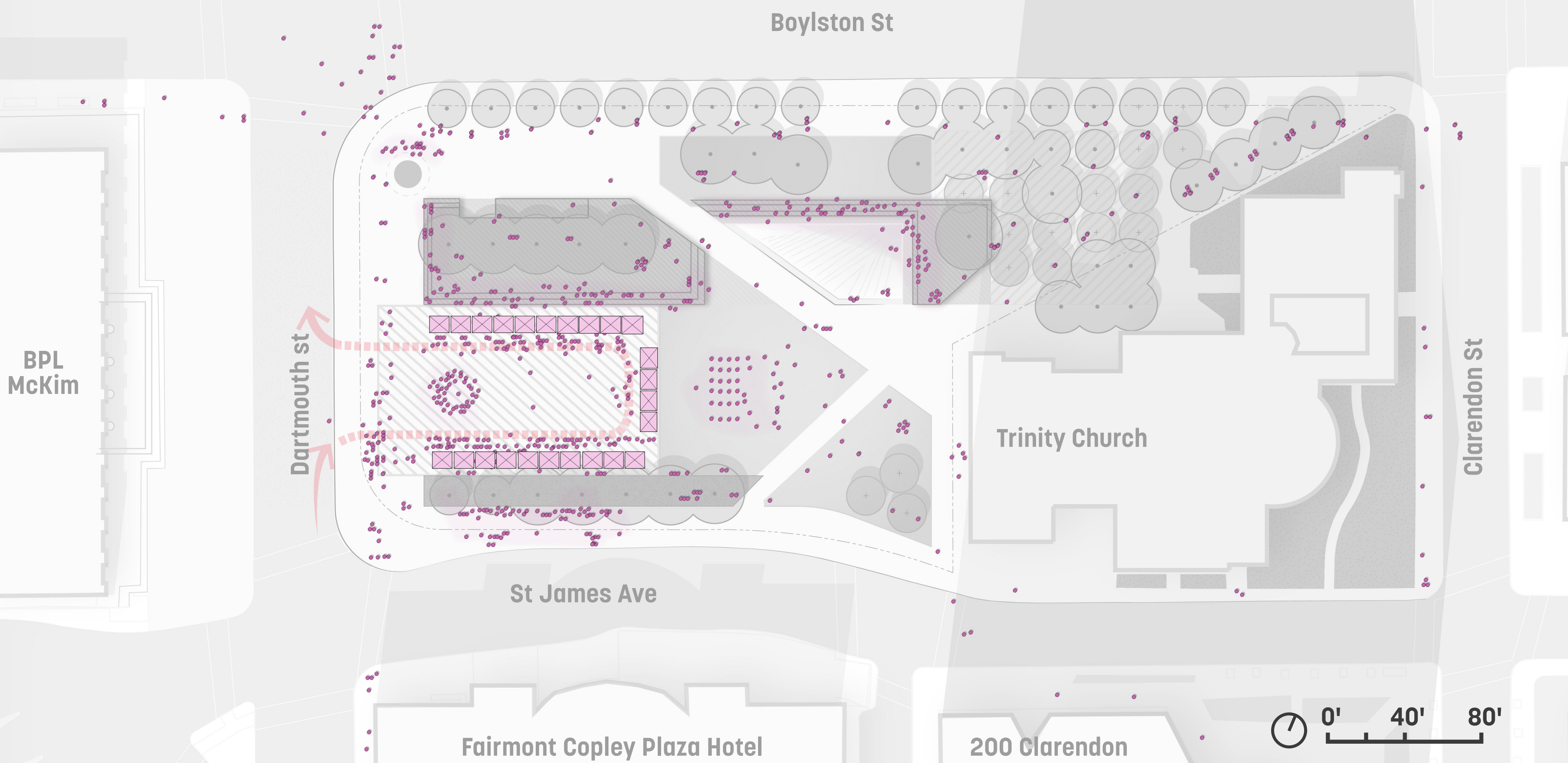

City Platform - Events

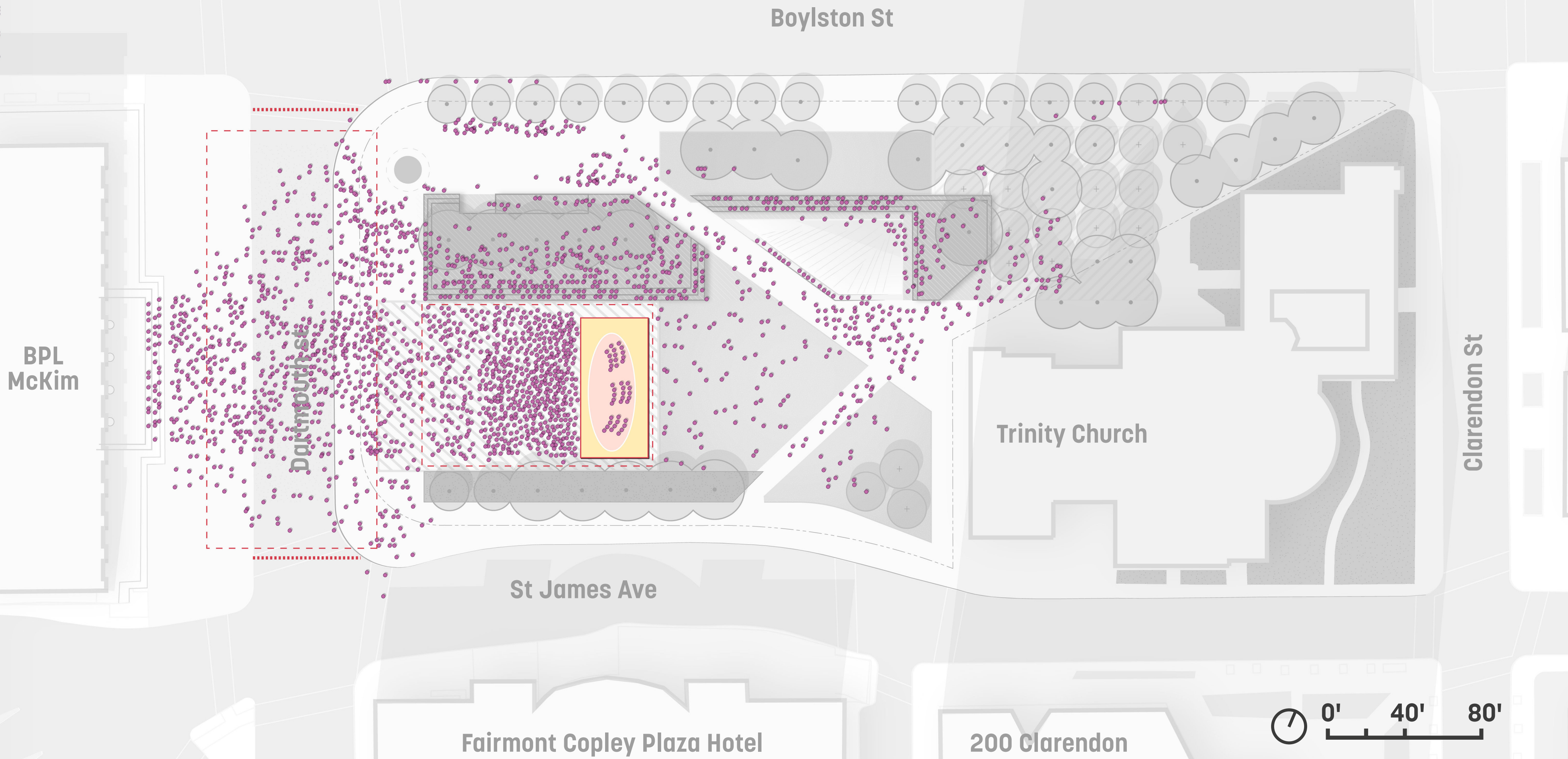

Boylston St

BPL
McKim

Dartmouth St

St James Ave

Clarendon St

Trinity Church

Fairmont Copley Plaza Hotel

200 Clarendon



City Platform
2022



Trees frame
the view

Flexible Edge

A front lawn for
Trinity



Raised Crossings

Connective pathways criss-cross a square defined by a linear plaza and planted gathering areas

Raised Crossings Plan

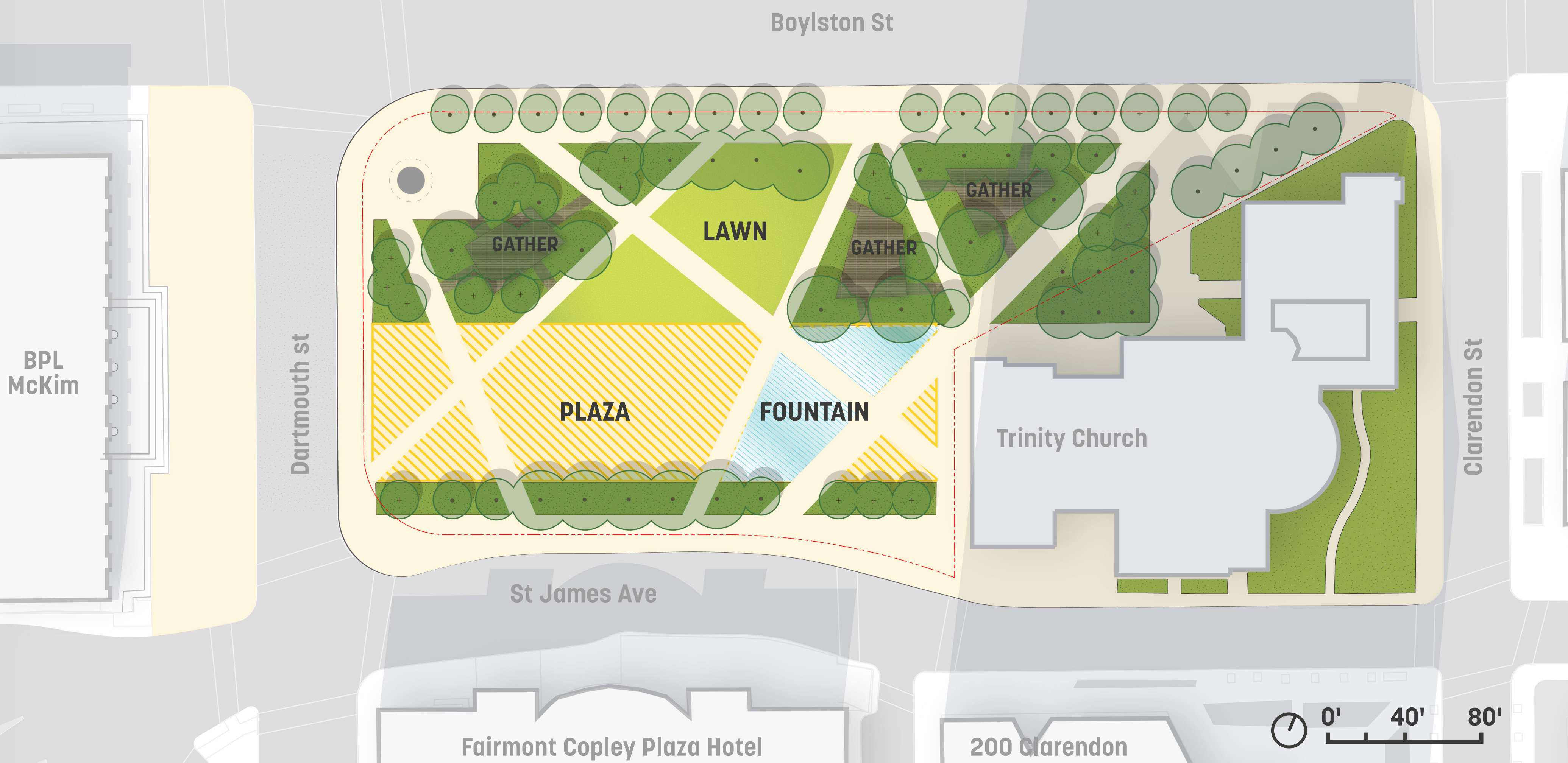

Boylston St

BPL
McKim

Dartmouth st

GATHER

LAWN

GATHER

GATHER

PLAZA

FOUNTAIN

Trinity Church

Clarendon St

St James Ave

Fairmont Copley Plaza Hotel

200 Clarendon

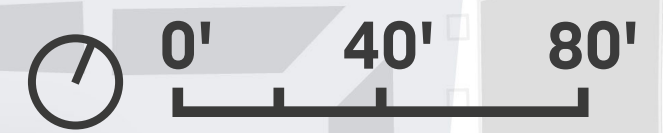



**PAVEMENT
PATTERN AND
TEXTURE**



**RAISED DECK AREAS
WITHIN PLANTING**

Raised Crossings Character



**FLEXIBLE FOUNTAIN
TRANSFORMS TO
PLAZA**



**PATHS CROSS
LAWN AREA**

Raised Crossings - Many Experiences Throughout the Seasons

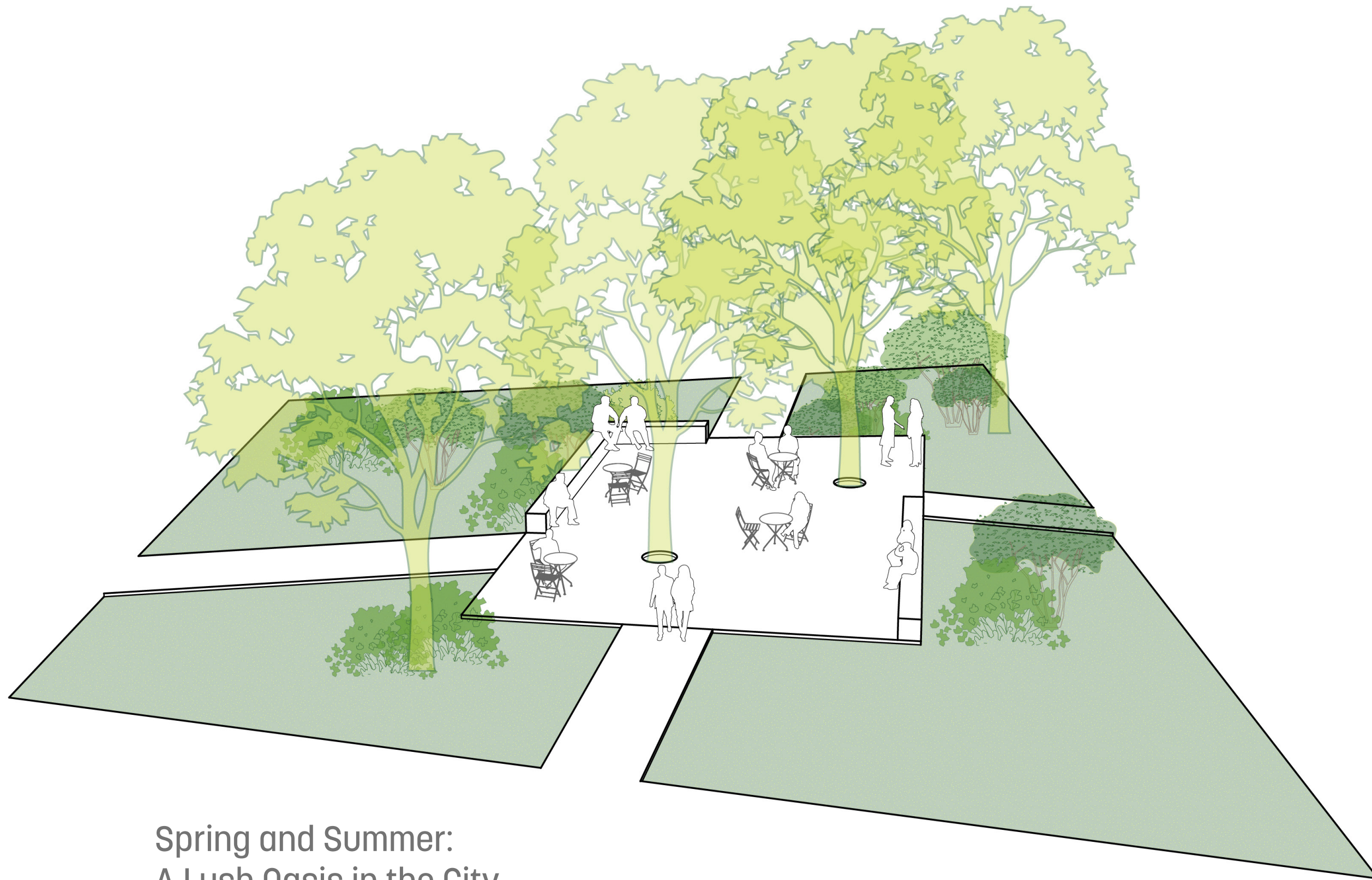

Spring and Summer:
A Lush Oasis in the City



Fall:
Flashes of Color

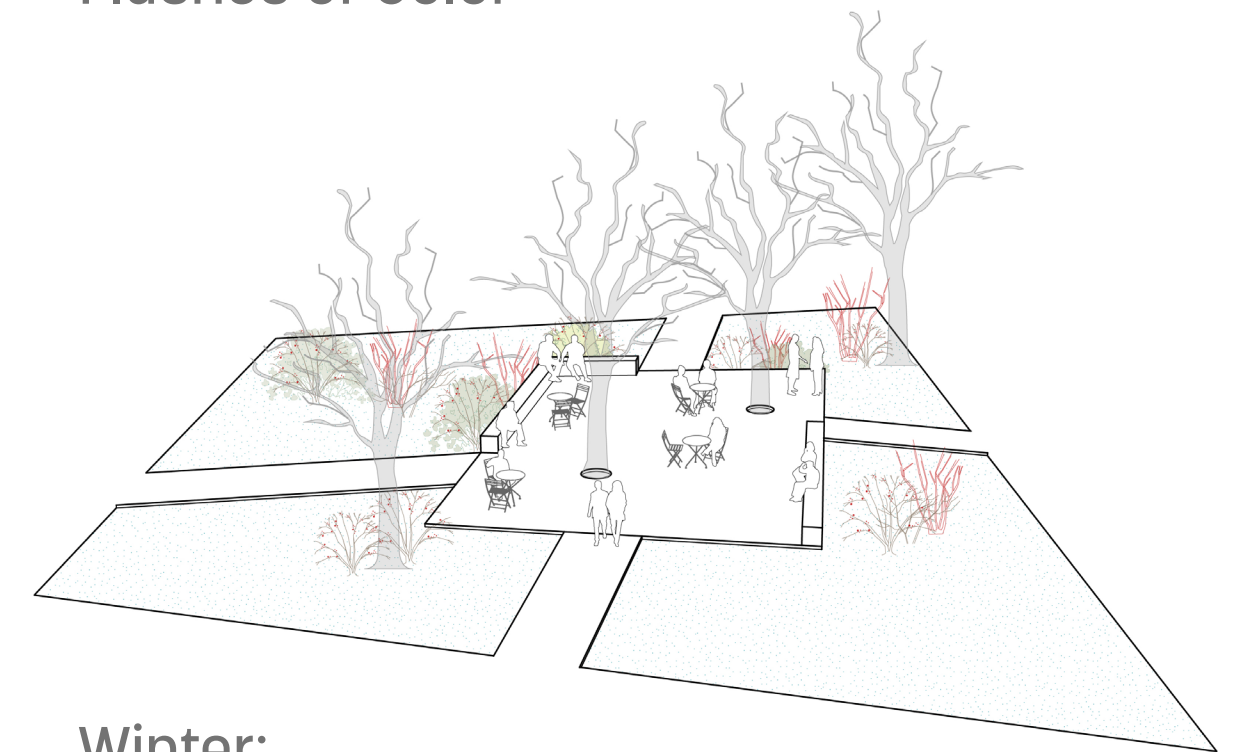

Winter:
Branching Habit and Structure

Raised Crossings - Weekly Use



BPL
McKim

Raised Crossings - Events

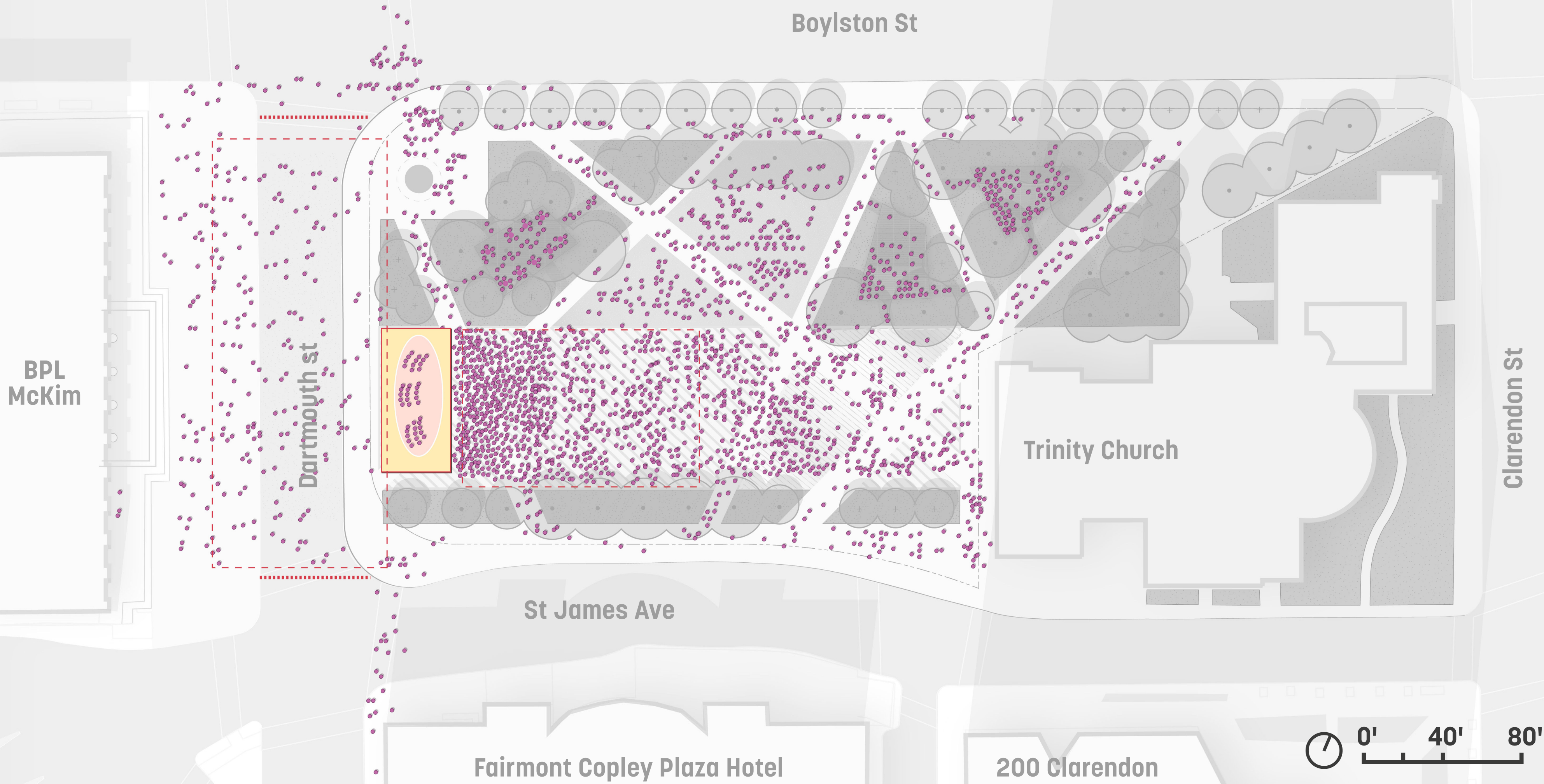

BPL
McKim

Dartmouth st

Boylston St

St James Ave

Clarendon St

Trinity Church

Fairmont Copley Plaza Hotel

200 Clarendon





Legacy trees

A fountain at Trinity's front steps

A comfortable space to gather

Open plaza

Raised Crossings, 2022



Framed Ellipse

Lush gardens with ample seating opportunities surround a cozy plaza at the heart of the square

Framed Ellipse Plan

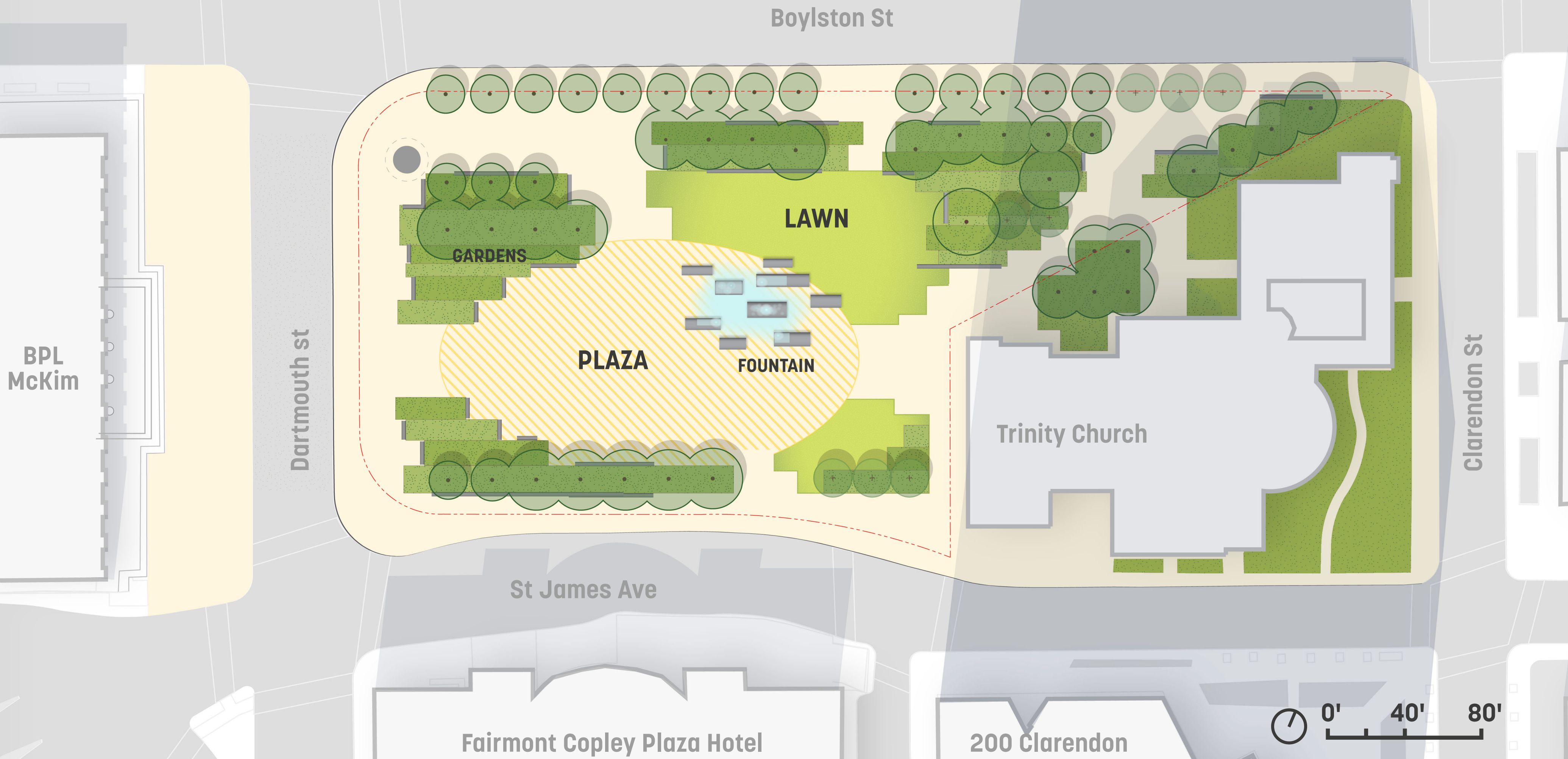

Boylston St

Dartmouth st

Clarendon St

St James Ave

BPL
McKim

Fairmont Copley Plaza Hotel

200 Clarendon

Trinity Church

LAWN

GARDENS

PLAZA

FOUNTAIN



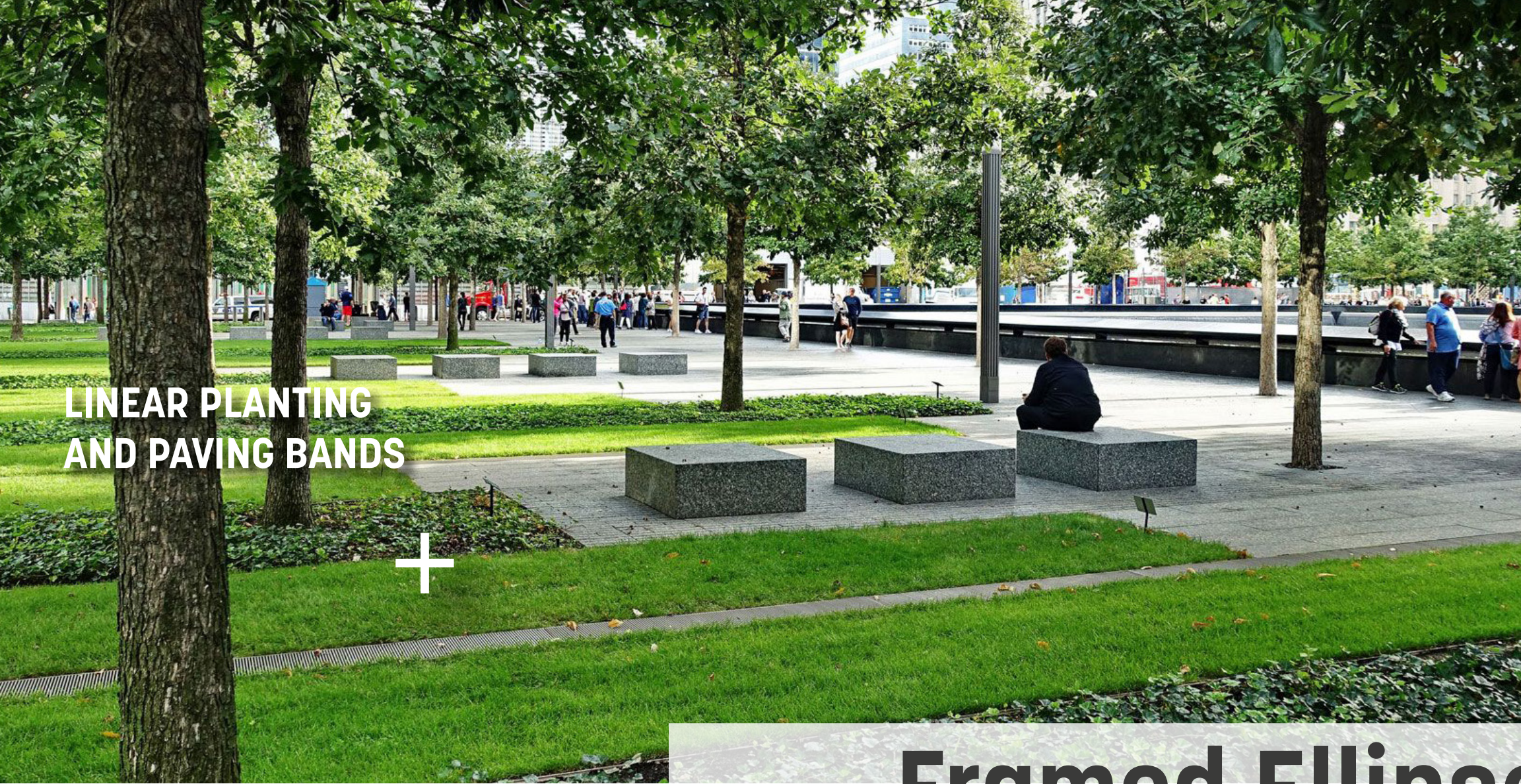

**LINEAR PLANTING
AND PAVING BANDS**



**SEATING AT THE EDGE
OF PLANTING**

Framed Ellipse Character

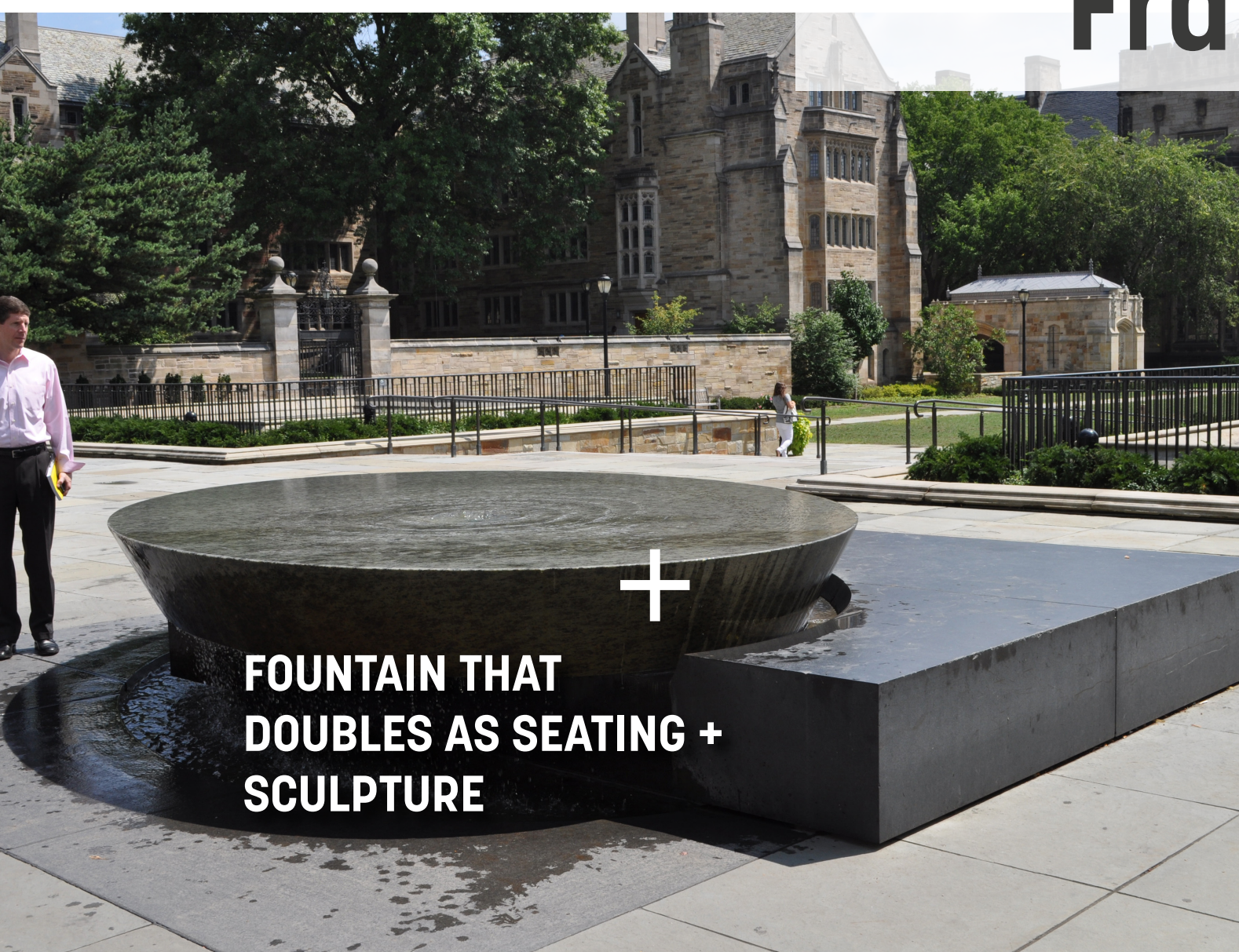

**FOUNTAIN THAT
DOUBLES AS SEATING +
SCULPTURE**

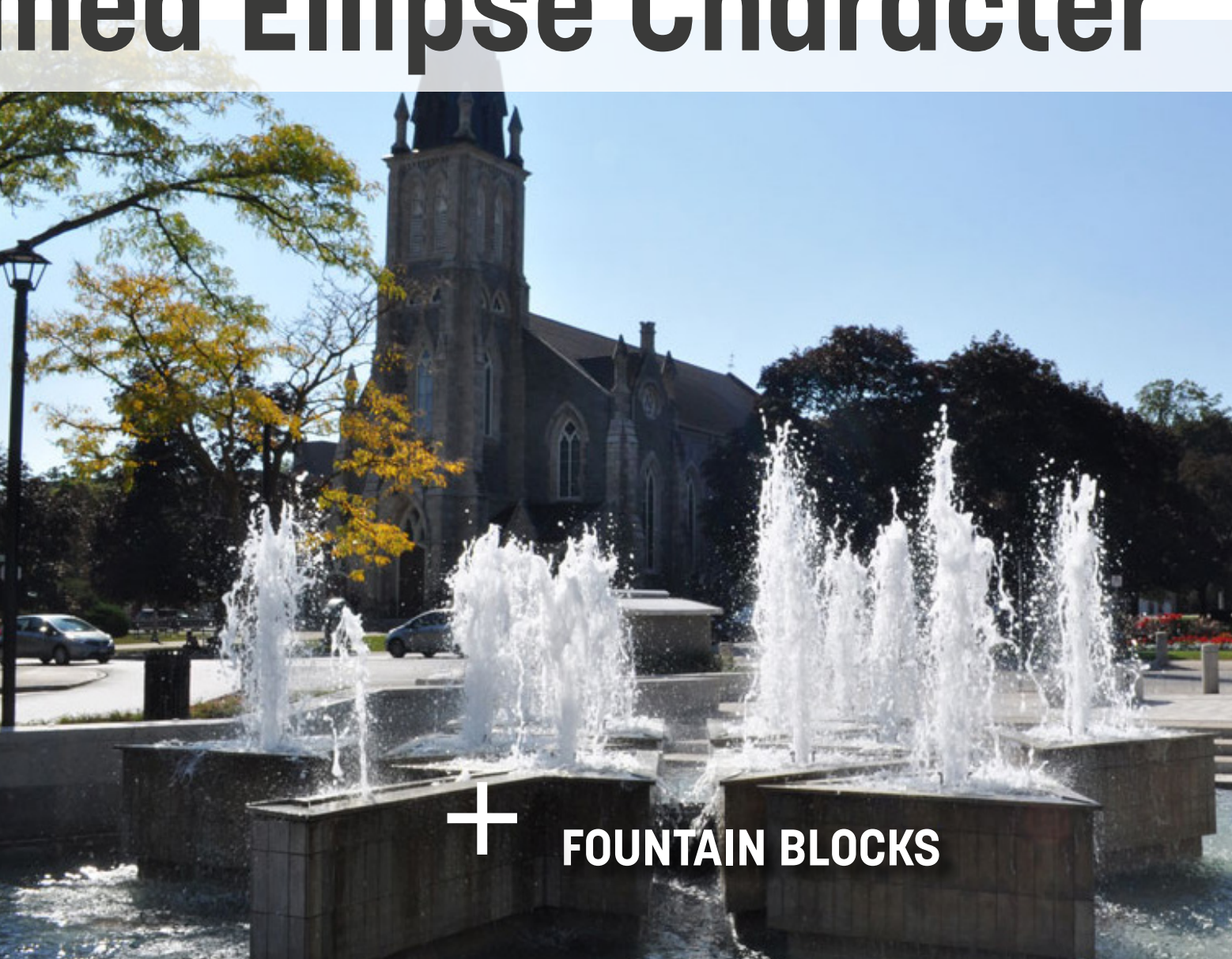

FOUNTAIN BLOCKS



SEATING BLOCKS

Framed Ellipse Plan - Option to Renovate Existing Fountain



Framed Ellipse - Bands Adapt to Create Spaces

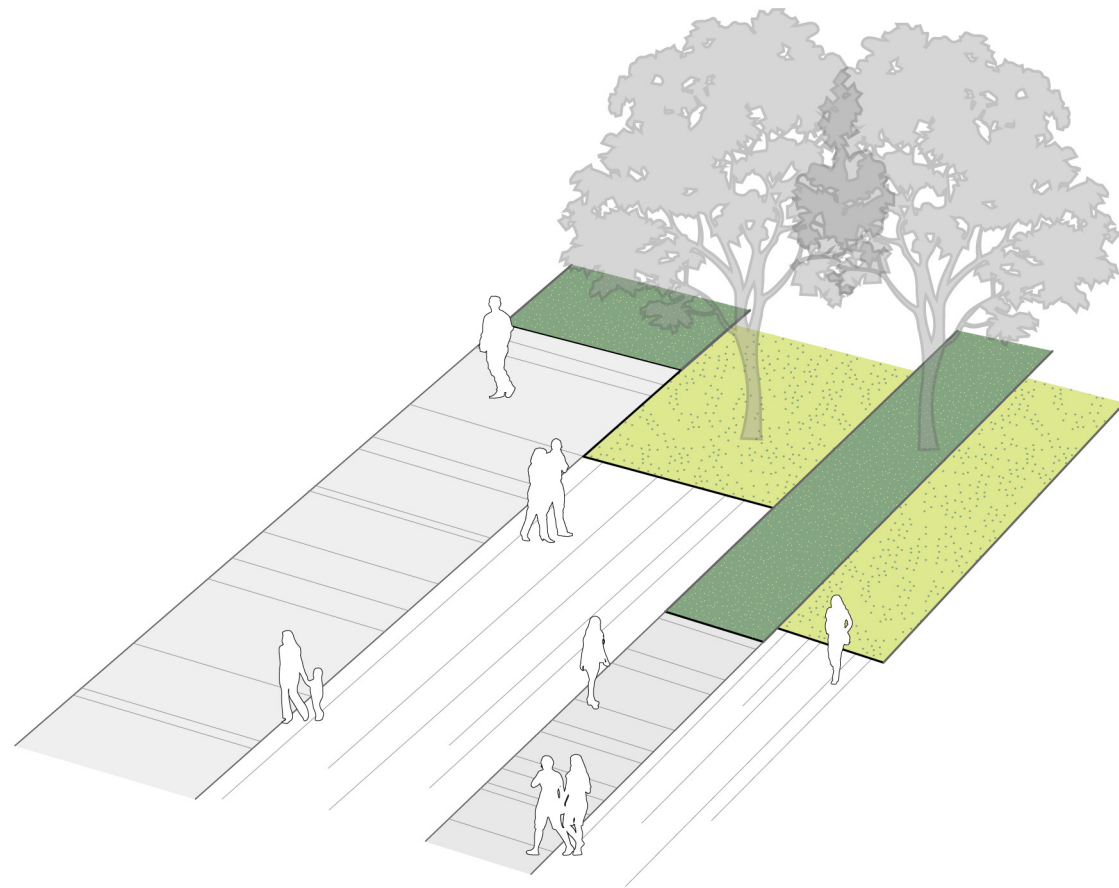

Pavement and Planting -
Bands of Texture

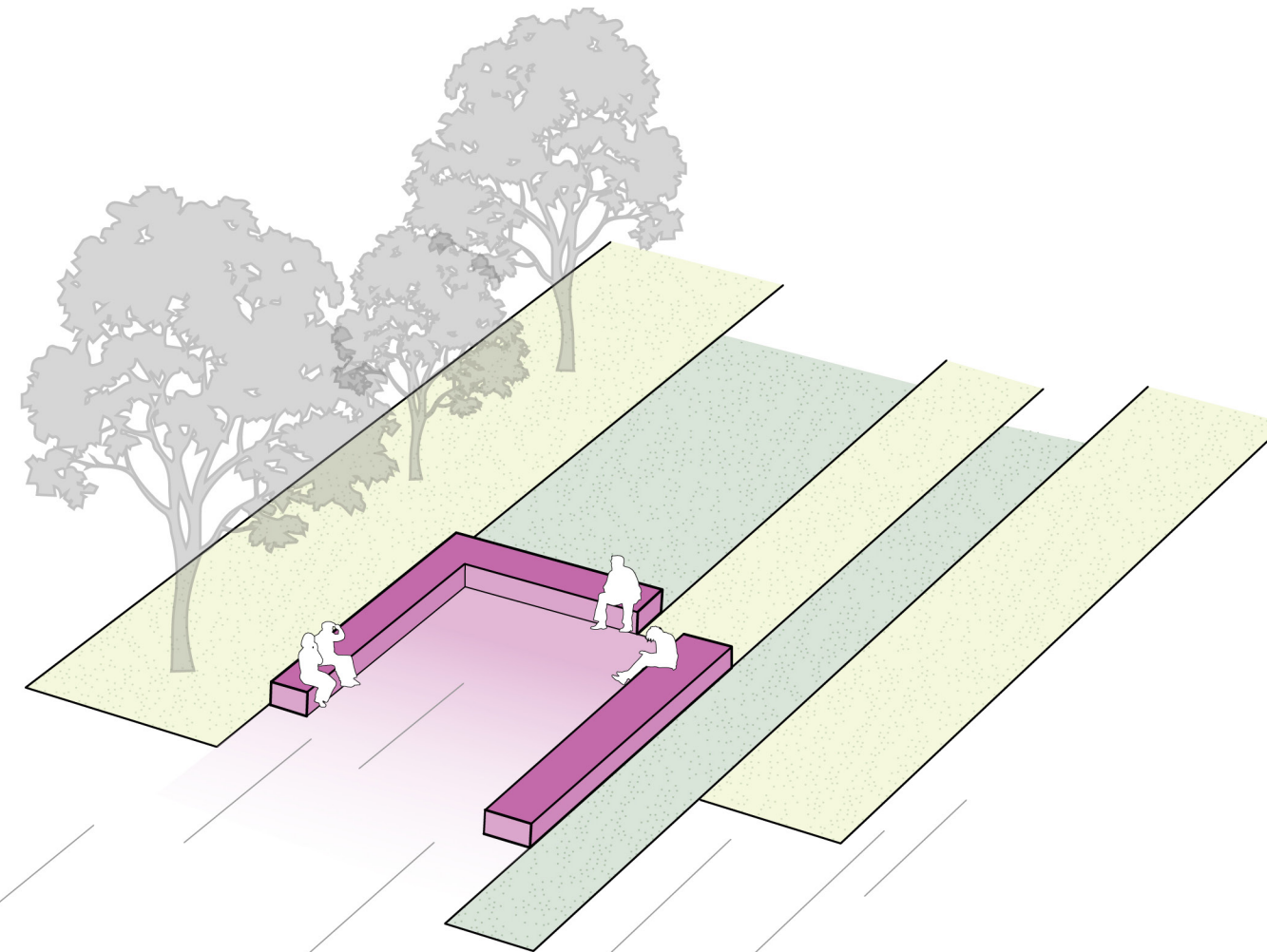

Seating Nodes at the Edge
between Paving and Planting

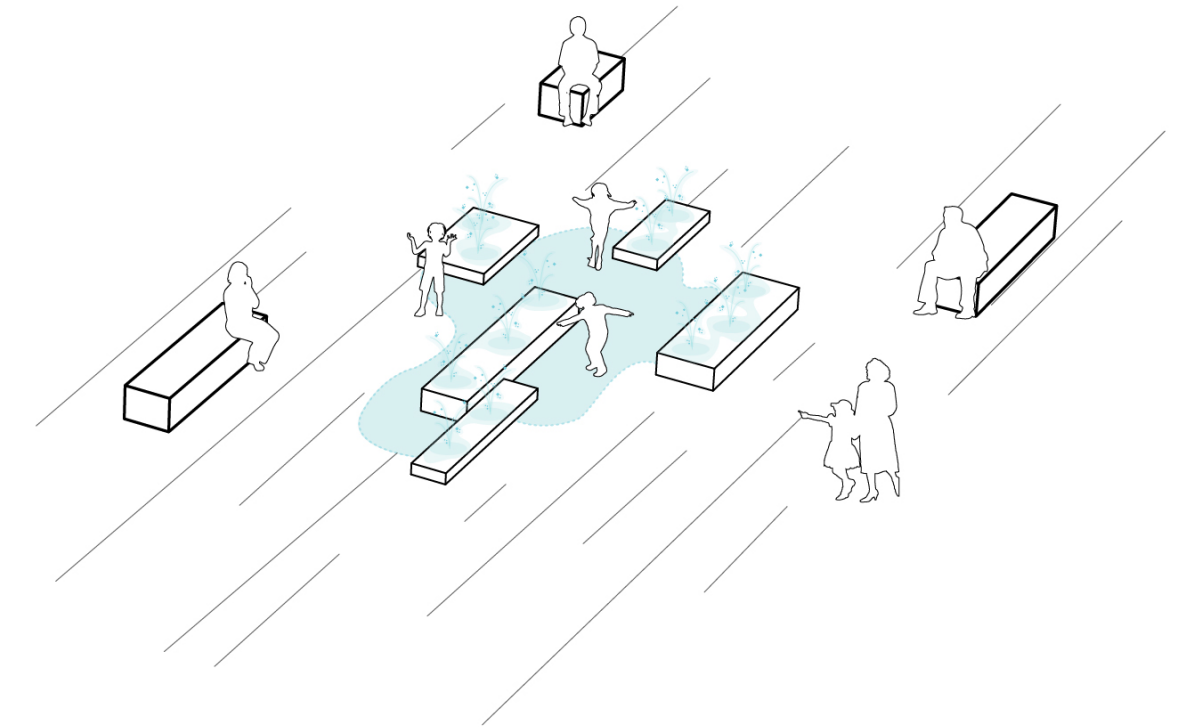

Fountain - Seating and
Sculptural Forms

Framed Ellipse - Weekly Use

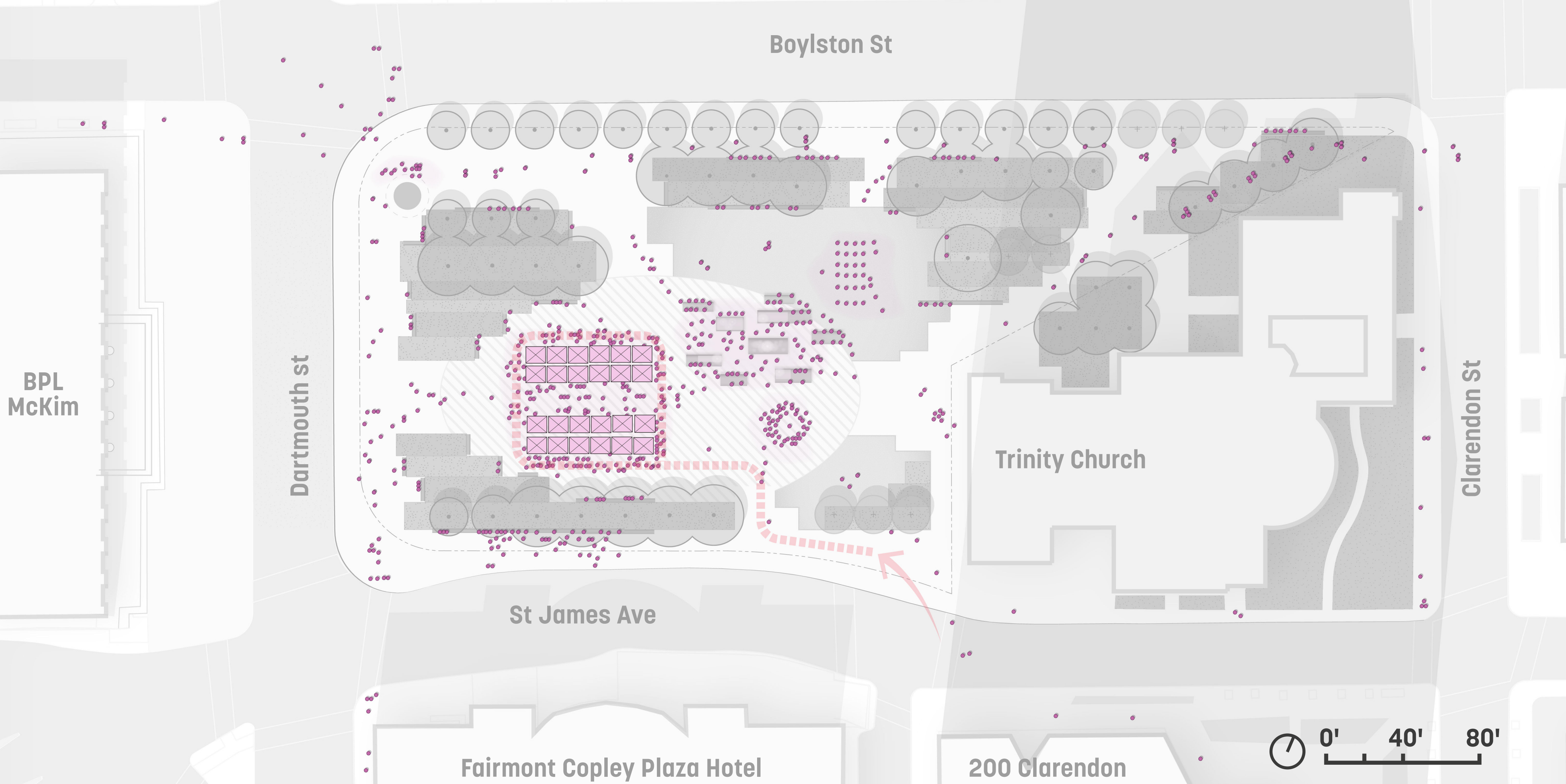

Boylston St

BPL
McKim

Dartmouth st

Clarendon St

Trinity Church

St James Ave

Fairmont Copley Plaza Hotel

200 Clarendon



Framed Ellipse - Events

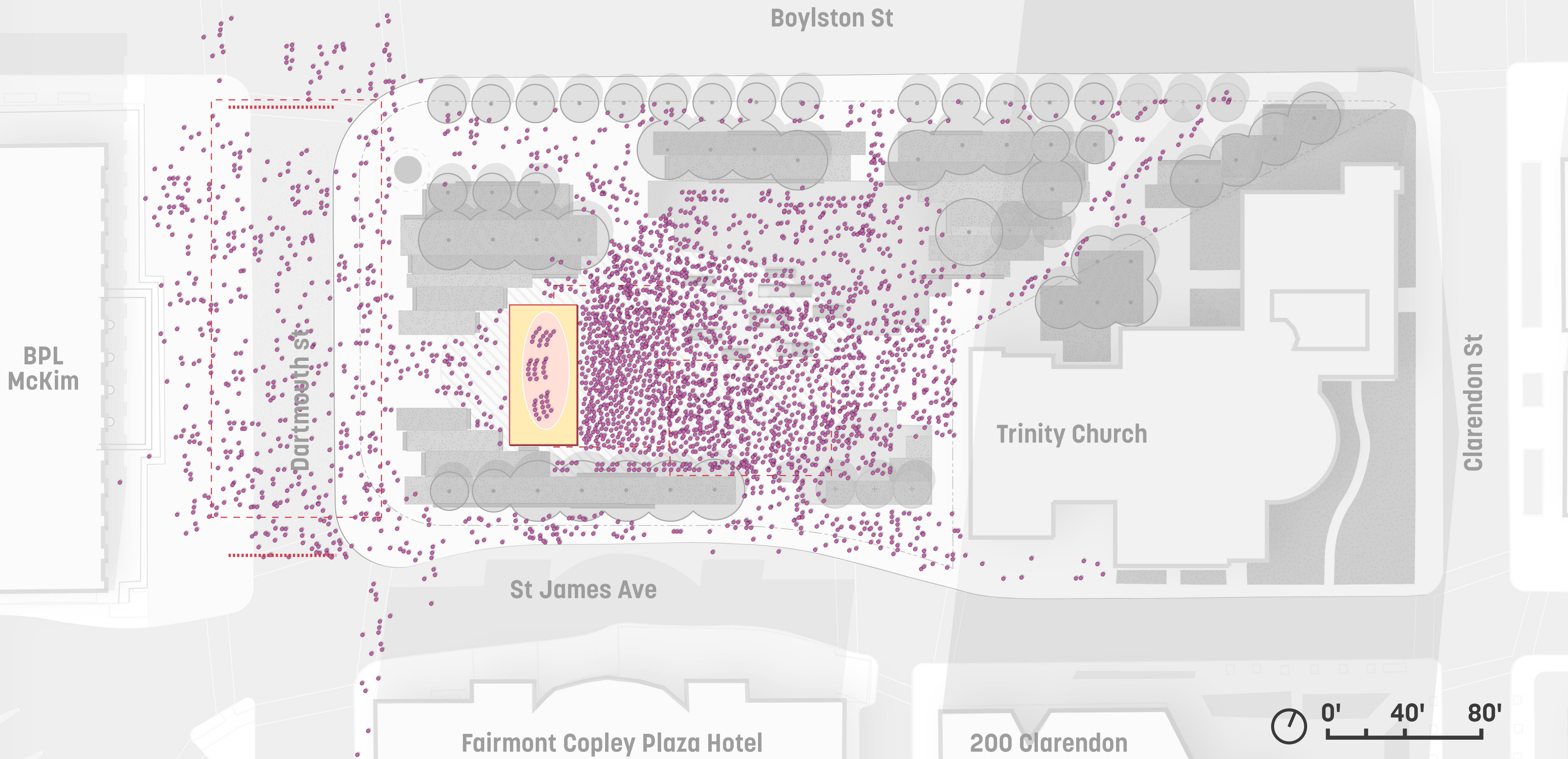



Seating

Fountain

Framed Ellipse, 2022

City Platform

A signature stage for civic life extends under Copley's legacy tree canopy, connecting lawn, plaza and fountain.



Raised Crossings

Connective pathways criss-cross a square defined by a linear plaza and planted gathering areas

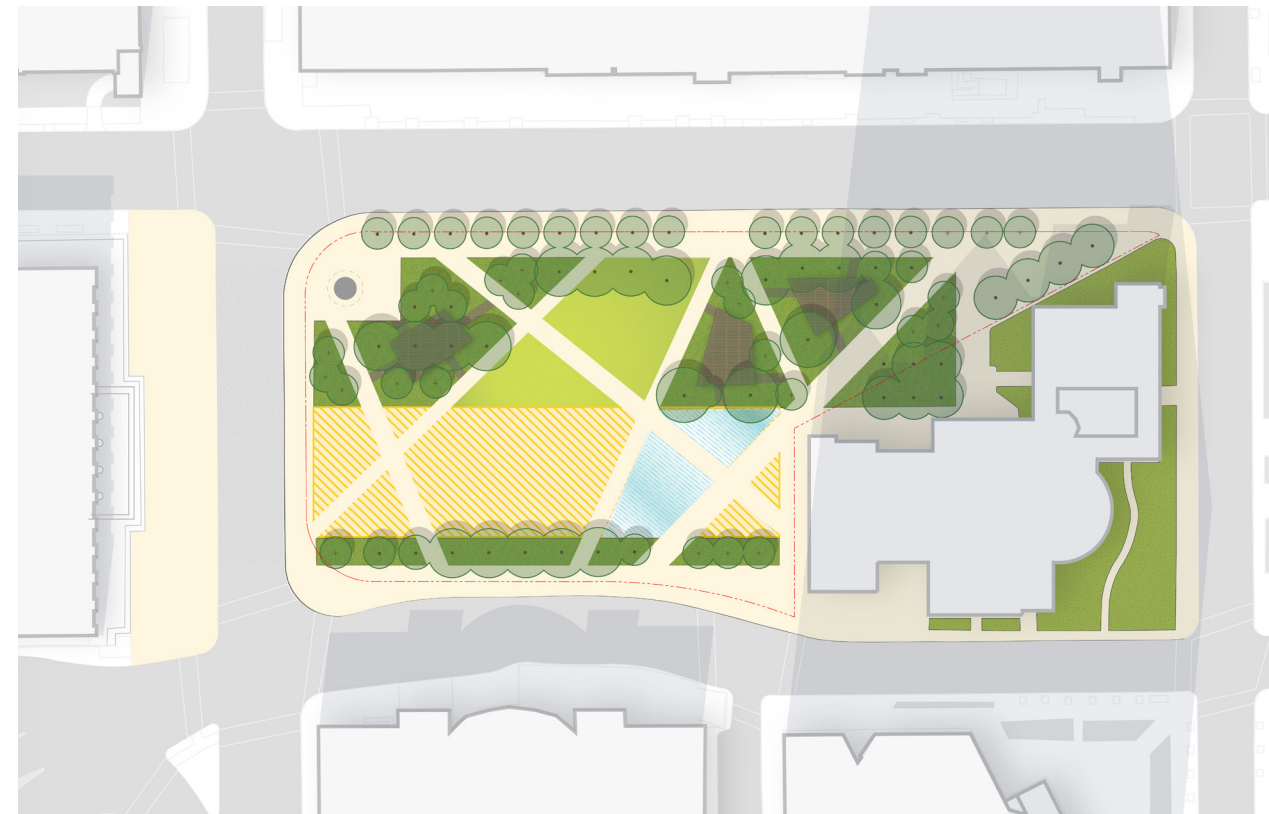

Framed Ellipse

Lush gardens with ample seating opportunities surround a cozy plaza at the heart of the square



Small Group Discussions



Small Groups

You will be placed into a zoom breakout room with a facilitator from the Design Team or Boston Parks

Timeframe: 30 minutes

Discussion Topics:
Which scheme has the best approach to:

- Legacy Trees
- The Fountain
- Architecture and Context
- Events and Programming

Summarize three big takeaways for a report back to the larger group

- **Listen actively to hear, not to respond**
- **We can disagree, respectfully**
- **Make space, take space**
- **Speak from your own experience, use “I” instead of “We”**
- **Goal is understanding, not agreement**
- **Be Present**

Next Steps



Zoom Controls



Q+A

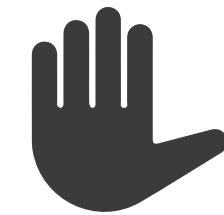

Raise Hand



Microphone

Click to mute
or unmute



Video

Click to show
or hide your
video

Join by Phone (Dial)

Press *9 to raise your hand

Press *6 to unmute/mute yourself

Take the Survey &
Share with Others



bit.ly/copley-survey-2

Updates & Info on
Project Website



bit.ly/copley-boston



What Comes Next

Fall 2020 Winter 2020 Spring 2021 Summer 2021 Fall 2021

SITE ANALYSIS

- Understand the Square's past and present
- Understand community perspective and vision for the future

PROGRAM + SCHEMATIC DESIGN

Concept Options



Refined Conceptual Plan

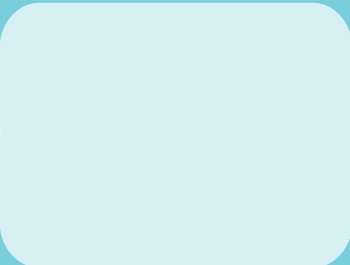

Next Meeting

DEFINITIVE DESIGN

Design Development



REFINED PLAN (SOME DETAIL)

Construction Documentation



ENOUGH DETAIL TO BUILD THE PROJECT

CONSTRUCTION

12 MONTHS

Estimated Budget: \$7.5m

Public + Stakeholder Meetings

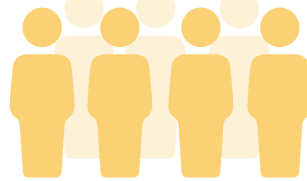
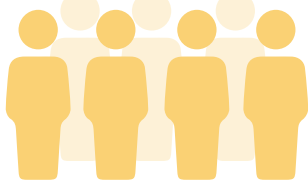

GOAL:

LISTEN

TEST CONCEPTUAL IDEAS

CONFIRM REFINED CONCEPT



ONGOING COORDINATION WITH BPL

Questions?

B Chatfield

Project Manager

abigail.chatfield@boston.gov

617-504-7709

Survey → bit.ly/copley-survey-2

Project Website → bit.ly/copley-boston

