

**1954 Commonwealth Avenue**

**November 2018 Design Review**

**Designs, Drawings and Specifications**



**DAVIS**  
**SQUARE**  
ARCHITECTS

240A Elm St., Somerville, MA 02144  
617.628.5700  
www.davisquarearchitects.com

Project  
**GATEWAY BRIGHTON**

Title  
**RENDERING**

Scale

Project No.  
**15012.00**

Date  
**10/15/2018**

Sheet No.

**A02**



**DAVIS  
SQUARE  
ARCHITECTS**

240A Elm St., Somerville, MA 02144  
617.628.5700  
www.davisquarearchitects.com

Project  
**GATEWAY BRIGHTON**

Title  
**RENDERING**

Scale

Project No.  
**15012.00**

Date  
**08/17/18**

Sheet No.

**A03**

© Copyright 2018 Davis Square Architects, Inc.



**DAVIS**  
**SQUARE**  
ARCHITECTS

240A Elm St., Somerville, MA 02144  
617-628-5700  
www.davisquarearchitects.com

Project  
**GATEWAY BRIGHTON**

Title  
**RENDERING**

Scale

Project No.

15012.00

Date

08/17/18

Sheet No.

**A04**

© Copyright 2018 Davis Square Architects, Inc.



Project: GATEWAY BRIGHTON

Sheet No.

Title: SITE PLAN

A01

240A Elm St., Somerville, MA 02144

617 628 5700

www.davisqsquarearchitects.com

Project No. 15012.00

Date 09/10/18

Scale 1/16" = 1'-0"

© Copyright 2016 Davis Square Architects, Inc.

**DAVIS**  
**SQUARE**  
**ARCHITECTS**







TOW ZONE  
Handicap  
Permit  
Parking  
←

Allston  
Original  
Resident  
Permit  
Parking  
Only

Handicap  
Permit  
Parking

25Z L81

**GATEWAY  
BRIGHTON**

1954  
COMMONWEALTH AVE.  
BOSTON, MA

**PLANTING NOTES**

- EXISTING CONDITIONS INFORMATION IS REPRODUCED FROM THE SURVEY PREPARED BY FELDMAN, OF BOSTON, MA, DATED 15 SEPTEMBER 2014.
- THE LOCATIONS OF UNDERGROUND UTILITIES SHOWN ARE BASED ON THE SURVEY REFERENCED ABOVE. THE CONTRACTOR SHALL CONTACT DIGSAFE AND THE PROPER LOCAL AUTHORITIES OR RESPECTIVE UTILITY COMPANIES TO CONFIRM THE LOCATION OF ALL EXISTING UTILITIES BEFORE COMMENCING WORK. ANY DAMAGE DUE TO FAILURE OF THE CONTRACTOR TO CONTACT THE PROPER AUTHORITIES SHALL BE BORNE BY THE CONTRACTOR.
- CONTRACTOR SHALL BEGIN MAINTENANCE IMMEDIATELY AFTER PLANTING AND WILL CONTINUE UNTIL FINAL WRITTEN ACCEPTANCE OF PLANT MATERIAL.
- LANDSCAPE ARCHITECT TO FLAG ALL TREES TO BE TRANSPLANTED PRIOR TO CONSTRUCTION START.
- CONTRACTOR SHALL VERIFY ALL TREE REMOVALS AND/OR TRANSPLANTS WITH OWNER'S REPRESENTATIVE PRIOR TO CONSTRUCTION START.
- CONTRACTOR SHALL MAINTAIN POSITIVE DRAINAGE AWAY FROM ALL BUILDING FOUNDATIONS, STRUCTURES, AND PLANTING BEDS.
- MAXIMUM SLOPE WITHIN DISTURBED AREAS SHALL NOT EXCEED 3:1, UNLESS OTHERWISE NOTED.
- THE LANDSCAPE CONTRACTOR SHALL SUPPLY ALL PLANT MATERIALS IN QUANTITIES SUFFICIENT TO COMPLETE ALL PLANTINGS SHOWN ON THIS DRAWING.
- ALL MATERIALS SHALL CONFORM TO THE GUIDELINES ESTABLISHED BY THE AMERICAN NURSERY AND LANDSCAPE ASSOCIATION.
- ALL PLANTS SHALL BEAR THE SAME RELATIONSHIP TO FINISH GRADE AS TO ORIGINAL GRADES BEFORE DIGGING.
- ALL PLANTS TO BE BALLED IN BURLAP OR CONTAINERIZED.
- MULCH FOR PLANTED AREAS TO BE ACED PINE BARK, PARTIALLY DECOMPOSED, DARK BROWN IN COLOR AND FREE OF WOOD CHIPS THICKER THAN 1/4 INCH.
- PLANTING SOIL MIX: LOAM THOROUGHLY INCORPORATED WITH ROTTED MANURE PROPORTIONED 5 C.Y. TO 1 C.Y. OR EQUIVALENT. FERTILIZER ADDED PER RECOMMENDED RATES OF SOILS ANALYSIS.
- THE LANDSCAPE CONTRACTOR SHALL GUARANTEE ALL PLANT MATERIALS FOR ONE (1) FULL YEAR FROM DATE OF ACCEPTANCE.
- ALL PLANT MATERIALS ARE SUBJECT TO THE APPROVAL OF THE LANDSCAPE ARCHITECT, AT THE NURSERY, AND AT THE SITE.
- ALL AREAS OF THE SITE WHICH HAVE BEEN DISTURBED AND NOT OTHERWISE DEVELOPED SHALL BE LOAMED AND SEEDING WITH A MINIMUM DEPTH OF 6" DEPTH TOPSOIL.
- PLANT SPECIES AS INDICATED IN THE PLANT LIST ARE SUGGESTIONS ONLY. FINAL SELECTION OF SPECIES SHALL OCCUR AT THE TIME OF PLANT PURCHASE, DEPENDING ON AVAILABILITY. PLANT SIZE AND QUANTITY SHALL NOT CHANGE WITHOUT APPROVAL OF OWNER'S REPRESENTATIVE.

**PLANTING LEGEND**

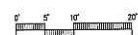
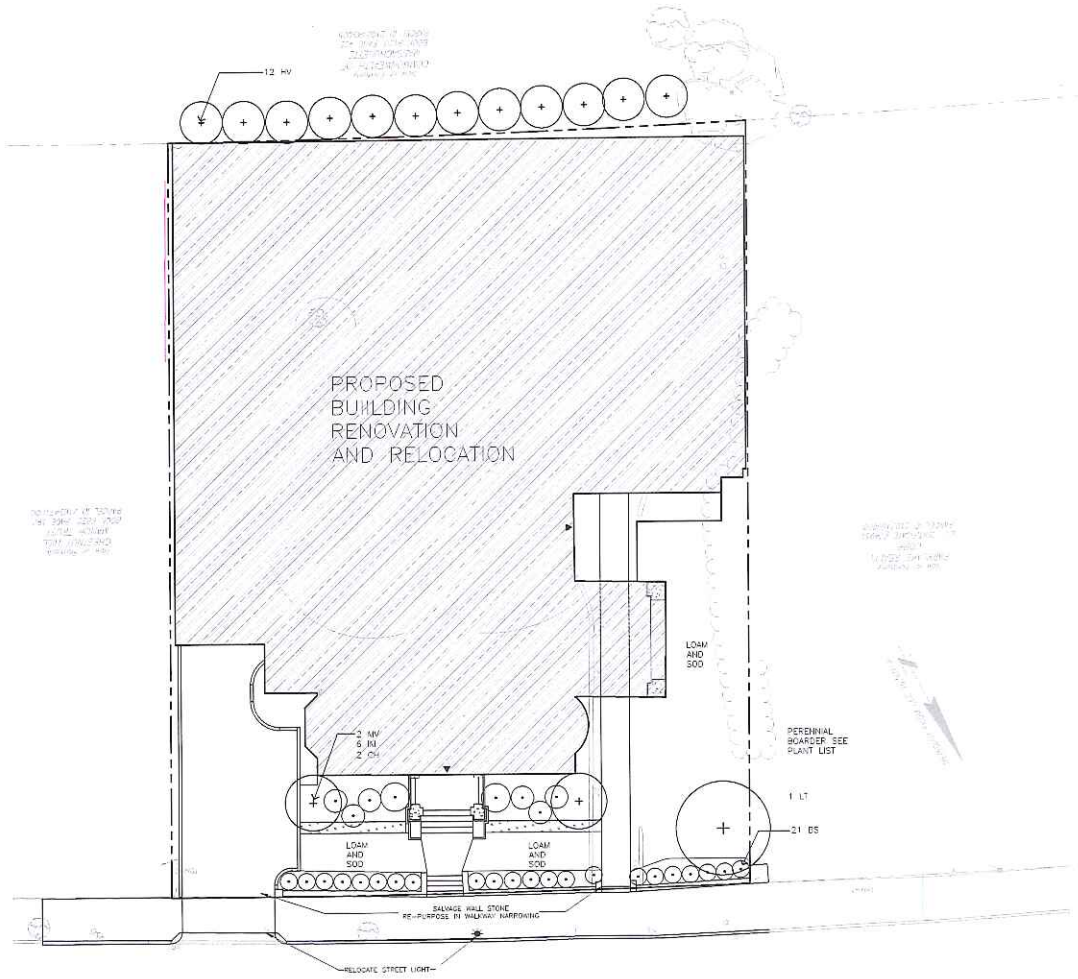
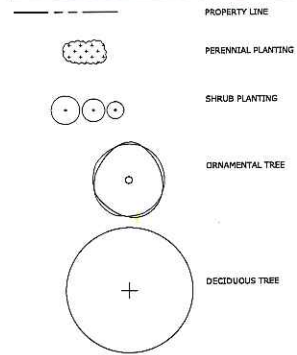

**PLANT SCHEDULE**

SYMBOL	BOTANICAL NAME	COMMON NAME	QTY	SIZE	COMMENT
<b>TREES</b>					
LT	LIRIODENDRON TULIPIFERA	TULIP TREE	1	2.5"-3" CAL	
MV	MAGNOLIA VIRGINIANA	SHRETBAY MAGNOLIA	2	5'-6' HT.	
SV	SYRINGA VULGARIS	COMMON LILAC	1	5'-6' HT.	
<b>TREES</b>					
BS	BUXUS SEMPERVIRENS	COMMON BOXWOOD	21	24"-30" HT.	
CH	CEPHALOTAXUS HARRINGTONI 'FASTIGIATA'	JAPANESE PLUM YEW	2	3'-4' HT. BAB	
HV	HAMAMELIS VIRGINIANA	WITCH HAZEL	12	3'-4' HT. BAB	
<b>PERENNIALS</b>					
	ALSEA RUSSICA	HOLLYHOCK	7	1 GAL	
	DIANTHUS SP.	SWEET WILLIAM	7	1 GAL	
	DIGITALIS SP.	FOXGLOVE	7	1 GAL	
	HELCERRA SP.	CORAL BELLS	7	1 GAL	

Land Planning, Civil Engineers  
Landscape Architecture  
P.O. Box 307  
Framingham, MA  
www.dzlandscape.com  
tel. 508.473.4114

**DeVellis Zrein  
Inc.**

**PLANTING  
PLAN**

SCALE: 1"=10'  
JOB: 2015-272  
FILE: 2015-272  
DRAWN: CRM  
CHECKED: CRM  
DATE: 8.16.18

**L-1**



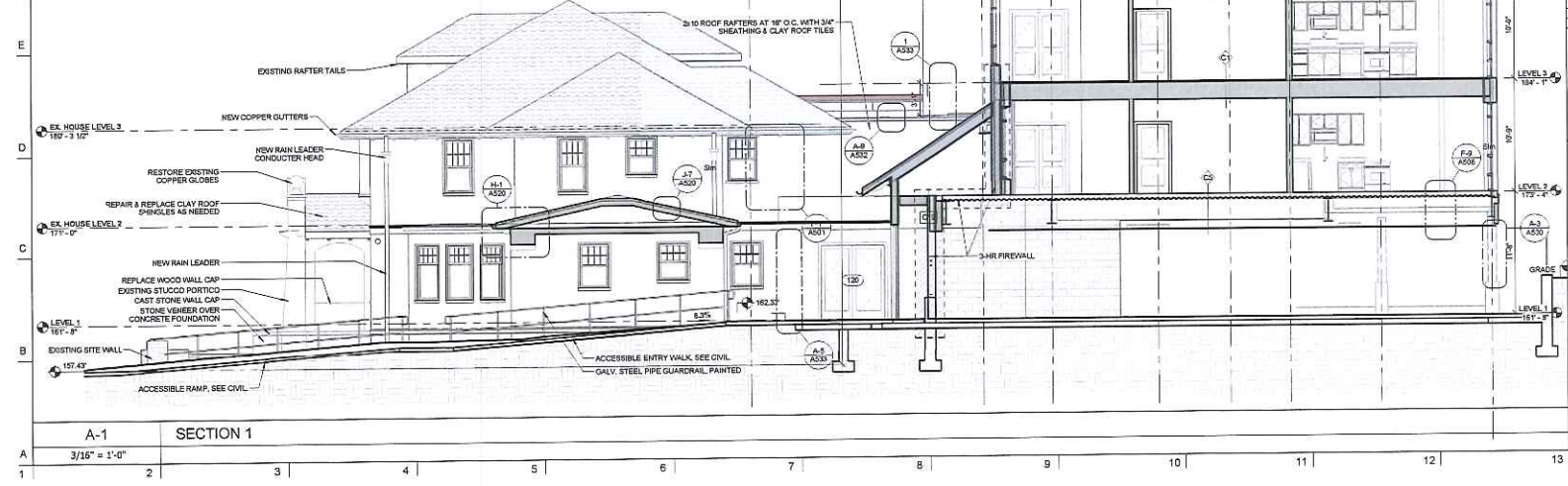
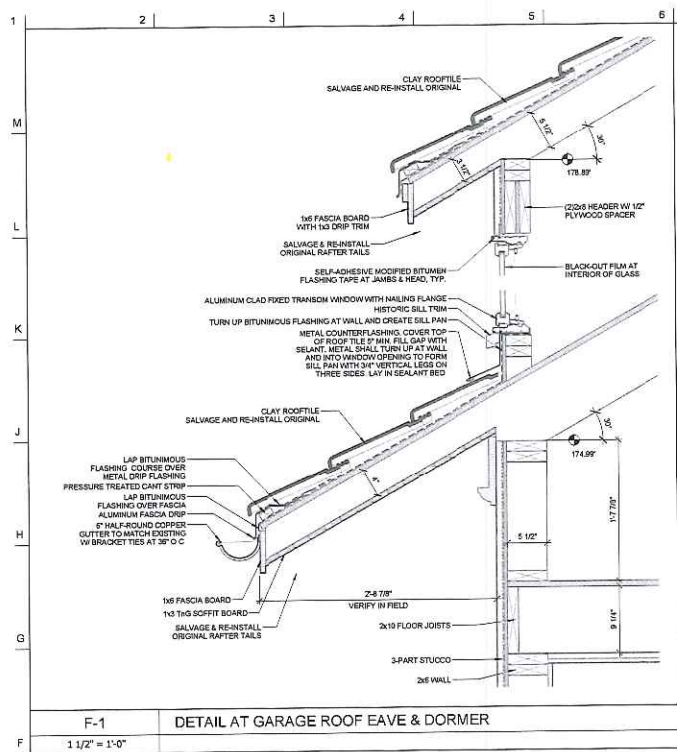

**NOTES**  
 DO NOT SCALE DRAWINGS.

NO.	REVISIONS/SUBMISSIONS	DATE

**DAVIS SQUARE ARCHITECTS**  
 242A Elm St.  
 Somerville, MA 02144  
 617.628.5700  
 www.davisquarearchitects.com

Project: HISTORIC PRESERVATION & ADDITION  
**GATEWAY BRIGHTON**  
 1854 COMMONWEALTH AVE., BOSTON, MA 02115  
 Title: **BUILDING SECTIONS**

Design: SW	Drawn: [ ]
Checker: [ ]	
Plot: [ ]	
Scale: As Indicated	
Date: 2016-12-16	

A501

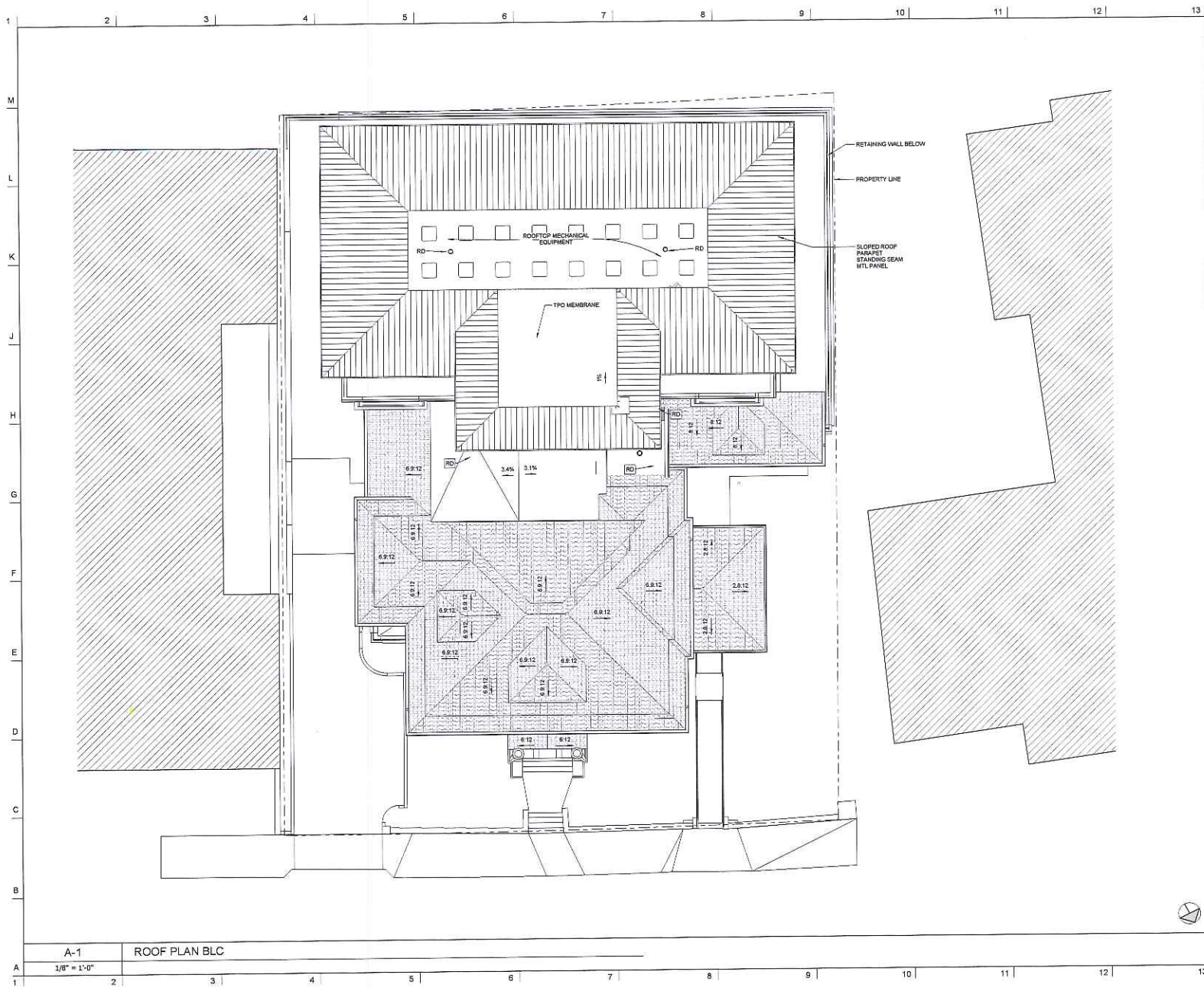

**NOTES**

DO NOT SCALE DRAWINGS

**GENERAL NOTES**

- THE FLAT ROOFS SHALL HAVE A FULLY ADHERED, SINGLE-PLY WHITE TPO MEMBRANE WITH A 1/2" COVER BOARD ABOVE THE FURRED INSULATION.
- THE PITCHED ROOFS AT THE HISTORIC STRUCTURE SHALL MATCH THE EXISTING STYLE & COLOR. THE BASIS-OF-DESIGN IN THE ARCHITECTURAL DRAWINGS IS A PRINCIPAL INTERLOCKING CLAY TILE SLATE RED BLEND.
- SLOPES AT THE "FLAT" ROOFS ARE SHOWN AS A PERCENTAGE.
- SLOPES AT THE "PITCHED" ROOFS ARE SHOWN AS AN ESTIMATED PISE-OVER-RUN.
- THE GC SHALL FIELD MEASURE THE SLOPES OF ALL PITCHED ROOFS OF THE EXISTING HISTORIC STRUCTURE BEFORE DEMOLITION/RELOCATION, AND INFORM THE ARCHITECT OF ALL FINDINGS.
- "PITCHED" ROOF SLOPES SHOWN IN THE ARCHITECTURAL DRAWINGS ARE ESTIMATED BY THE ARCHITECT FOR THE PURPOSES OF DESIGN.

**NUMBERED NOTES**

1. ROOF OVERHANGS SEE DETAILS

**KEY:**

- FLOOR LEVEL
- GRID HEAD AND GRID CENTERLINE
- 1/ATF DETAIL DRAWING CALL-OUT
- 1/AS1 SECTION DRAWING CALL-OUT
- ↑ NORTH ARROW
- RD ROOF DRAIN SEE PLUMBING
- RA FALL PROTECTION ROOF ANCHOR

HEAVY RED LINES INDICATE THE EXISTING STRUCTURES THAT ARE TO BE RELOCATED TO THE FRONT YARD. THE EXTERIOR WALL FRAMING SHALL REMAIN INTACT.

ALL INTERIOR AND EXTERIOR FINISHES SHALL BE NEW AS SHOWN ON THESE PLANS. GENERAL CONTRACTOR SHALL PROVIDE AN ALLOWANCE FOR ANY INTERIOR ROUGH FRAMING AS NOTED ON THE STRUCTURAL PLANS.

No.	REVISIONS/SUBMISSIONS	Date

**DAVIS SQUARE ARCHITECTS**  
 240A Elm St.  
 Somerville, MA 02144  
 617.628.5700  
 www.davisqsquarearchitects.com

Project: HISTORIC PRESERVATION & ADDITION  
 GATEWAY BRIGHTON  
 1954 COMMONWEALTH AVE., BOSTON, MA 02115

Title: ROOF PLAN

Drawn: SW  
 Checked: [Signature]  
 Date: 10/12/20  
 Scale: As Indicated  
 Date: 10/10/2014

**A180**

A-1 ROOF PLAN BLC  
 1/8" = 1'-0"

© Copyright 2015 Davis Square Architectural, Inc.

New or Formerly  
COMMONWEALTH OF  
MASSACHUSETTS  
BOOK 9120, PAGE 405  
PARCEL ID 2102470005

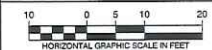
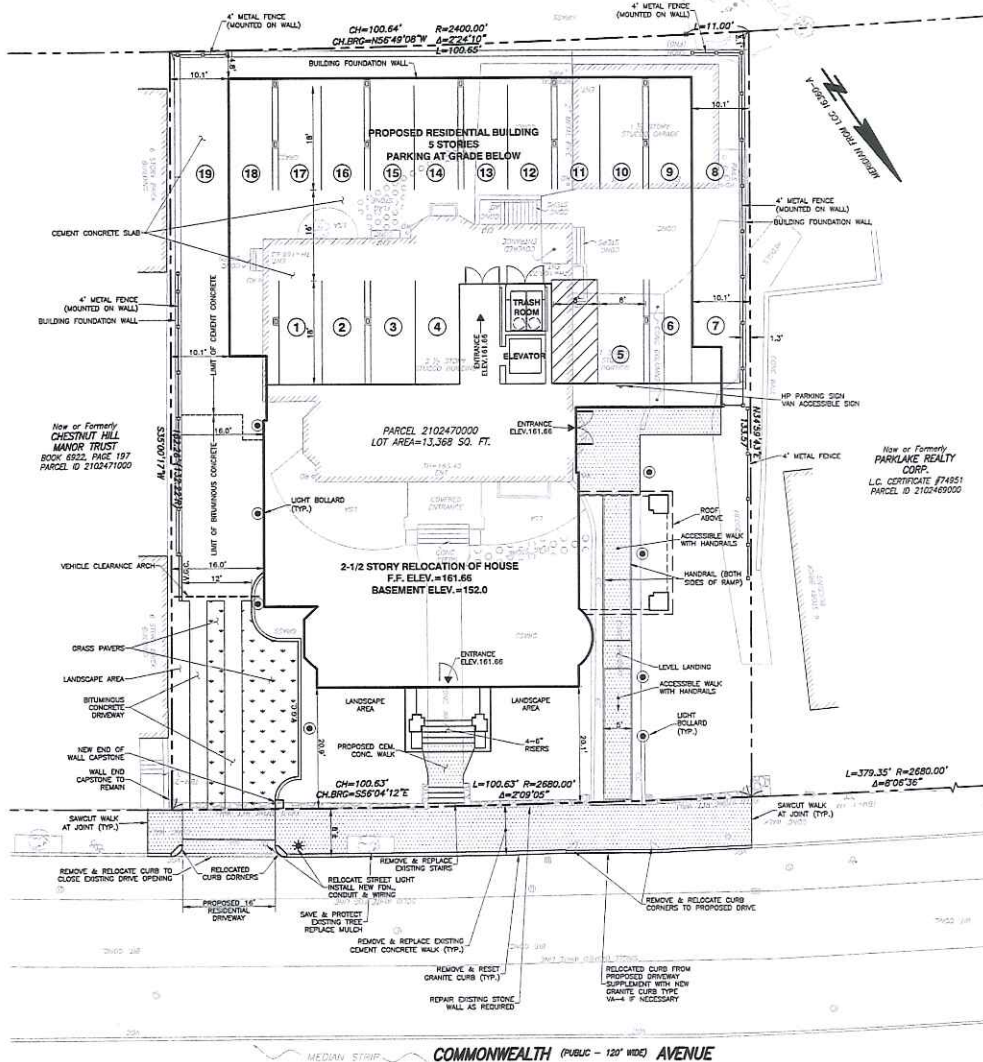

REVISIONS	

ISSUE	DATE	DESCRIPTION

DATE: OCT. 18, 2018  
SCALE: 1" = 10'  
SHEET C-1

GATEWAY BRIGHTON  
1954 COMMONWEALTH AVENUE  
BOSTON, MASSACHUSETTS

SITE PLAN  
AND  
EXTERIOR LIGHTING PLAN

hwmoore ASSOCIATES, INC. CIVIL ENGINEERING LAND PLANNING

112 Shawmut Avenue, Boston, MA 02118-2227  
TEL: 617-357-8145 FAX: 617-357-8485 WEB: hwmoore.com

REFERENCE:  
EXISTING PROPERTY LINE, TOPOGRAPHIC AND UTILITY INFORMATION IS TAKEN FROM A DIGITAL FILE RECEIVED ON FEBRUARY 17, 2018 AND NAMED "ASBES 3090411.DWG" OF A PLAN TITLED "EXISTING CONDITIONS PLAN, 1954 COMMONWEALTH AVE, BOSTON, MASS" DATED SEPTEMBER 16, 2014. PLAN PREPARED BY FELDMAN LAND SURVEYORS OF BOSTON, MA.  
PROPOSED BUILDING TAKEN FROM A DIGITAL FILE RECEIVED ON OCTOBER 18, 2018 NAMED "181018-01-PLAN" PLAN FILE PREPARED BY DAVIS SQUARE ARCHITECTS, INC. OF SOMERVILLE, MA.

ENGINEER  
H.W. MOORE ASSOCIATES, INC.  
112 SHAWMUT AVENUE  
BOSTON, MA 02118  
TEL: 617-357-8145

OWNER / APPLICANT  
YU INVESTMENT TRUST  
675 VPW PARKWAY, #120  
CHESTNUT HILL, MA 02167  
TEL: 617-760-7605  
CONTACT: DAN YU

PROJECT ADDRESS  
1954 COMMONWEALTH AVE  
BOSTON, MA 02135-8002

File Name: C:\Projects\181018-01\181018-01-11.dwg, Saved: 06/13/2018 11:59 AM, Plotted: 05/14/2018 11:59 AM, No. of Sheets: 10, Plot Style: hwsoc.dwt, Plotter: AutoCAD

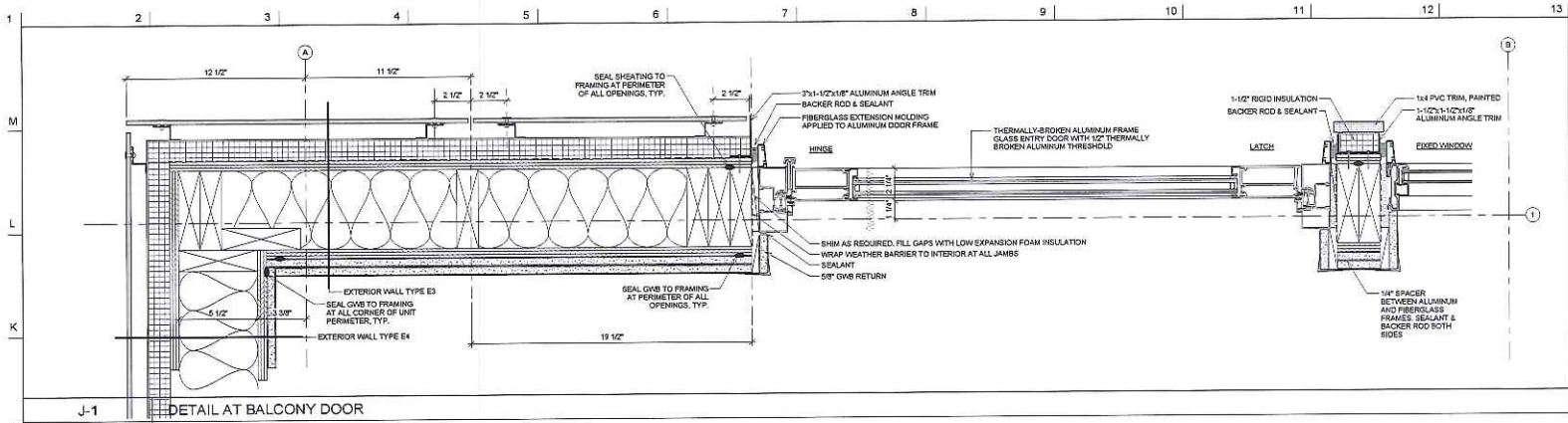

**NOTES**

DO NOT SCALE DRAWINGS.

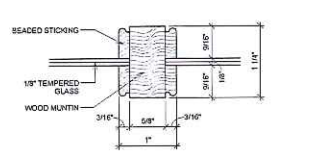
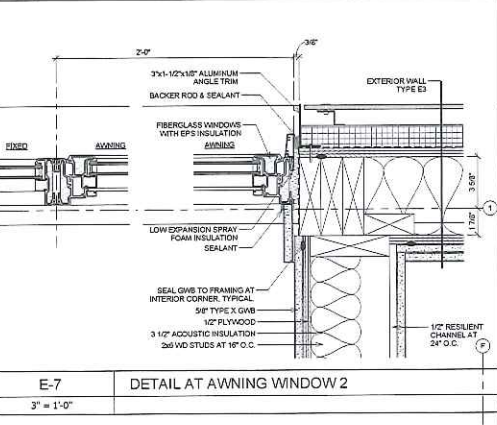
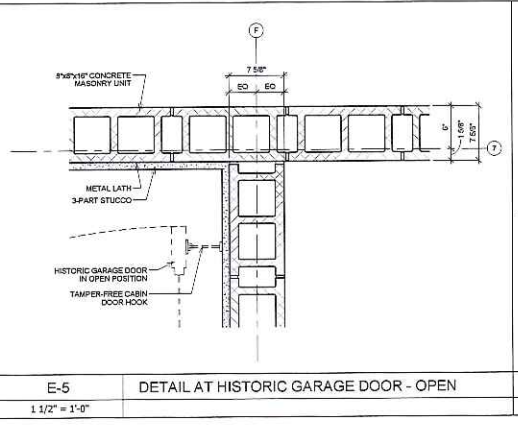
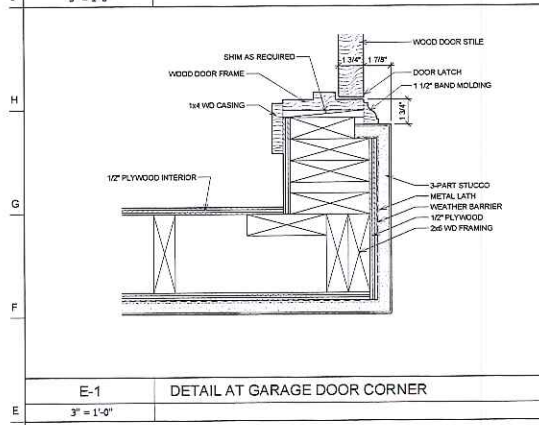

**6** DETAIL GARAGE MUNTIN  
12" = 1'-0"

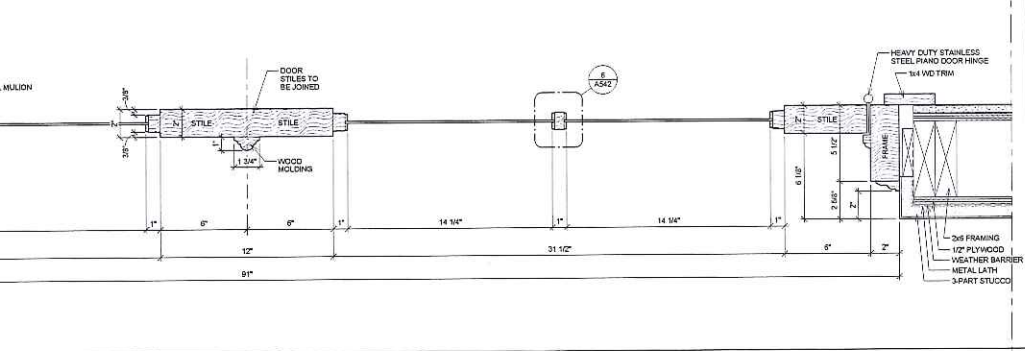
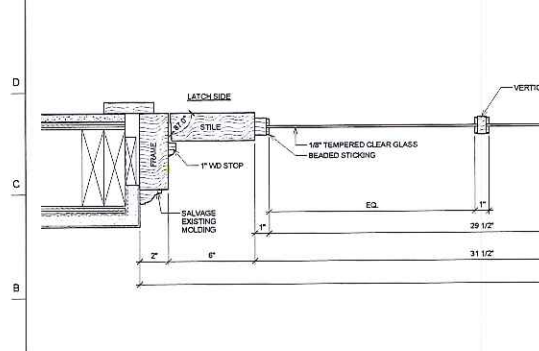

**DAVIS SQUARE ARCHITECTS**  
 242A Elm St.  
 Somerville, MA 02144  
 617.628.5700  
 www.davis-square-architects.com

Project: HISTORIC PRESERVATION & ADDITION  
**GATEWAY BRIGHTON**  
 1954 COMMONWEALTH AVE., BOSTON, MA 02115

Drawn: BW  
 Checked: [Signature]  
 Date: 12/12/20  
 Scale: As Indicated  
 Date: 2016-12-16

**A542**

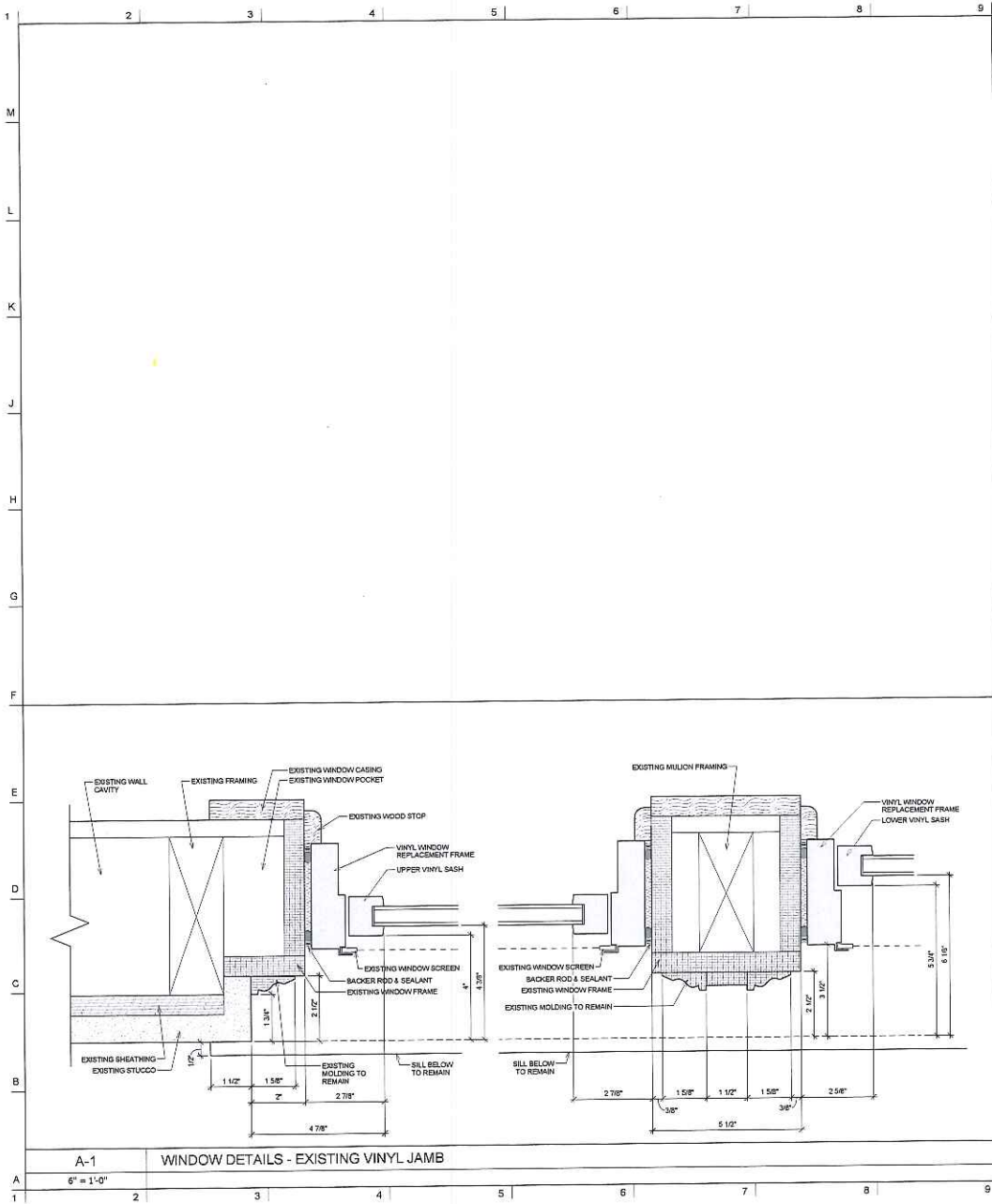

A-1 WINDOW DETAILS - EXISTING VINYL JAMB

6" = 1'-0"

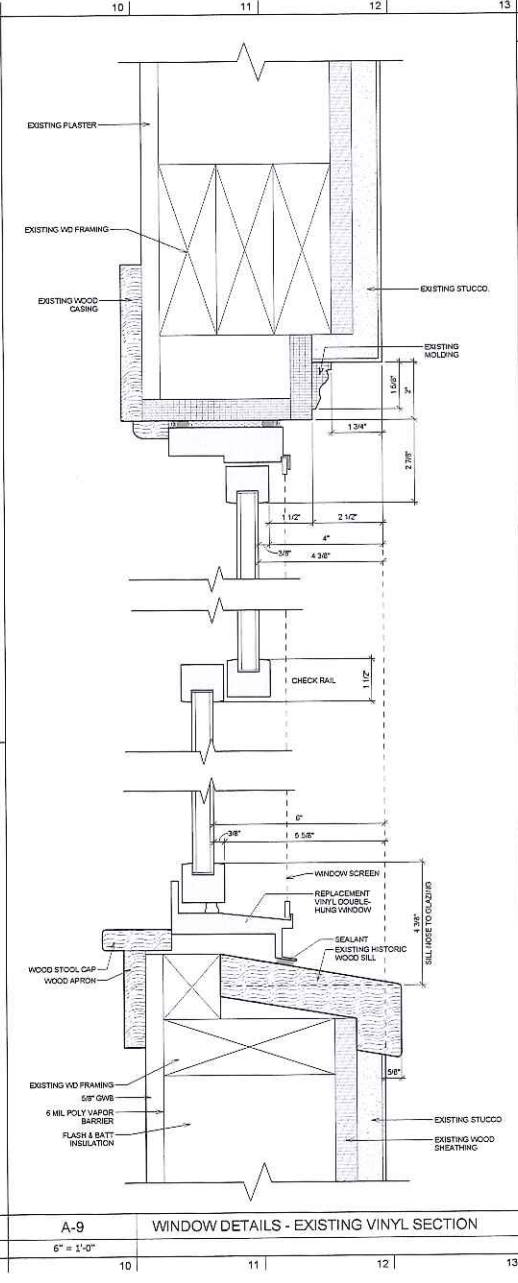

A-9 WINDOW DETAILS - EXISTING VINYL SECTION

6" = 1'-0"

NOTES

DO NOT SCALE DRAWINGS

No.	REVISIONS/SUBMISSIONS	Date
-----	-----------------------	------



240 N. Elm St.  
Somerville, MA 02144  
617.628.3700  
www.davis-square-architects.com

Consultant

Project: HISTORIC PRESERVATION & ADDITION  
GATEWAY BRIGHTON  
1954 COMMONWEALTH AVE., BOSTON, MA 02125

Title: EXISTING VINYL WINDOW DETAILS

Design: BVY  
Checked:  
Date: 1/31/12  
Scale: 6" = 1'-0"  
Date: 2015-12-16

A550

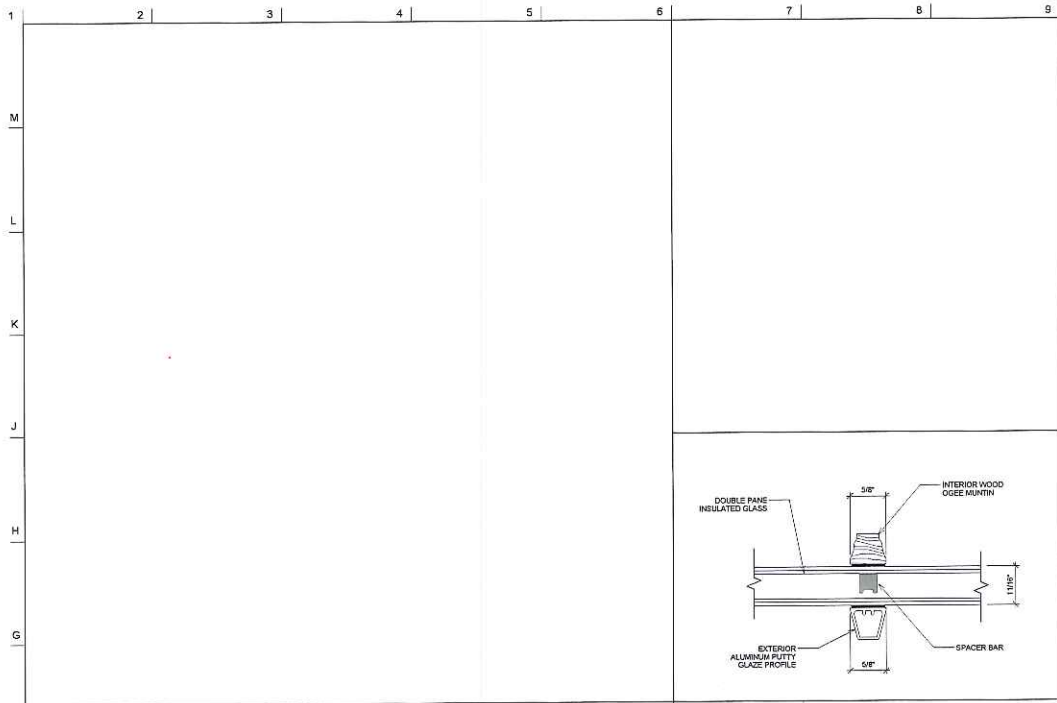

F-6 MUNTIN DETAIL  
12" = 1'-0"

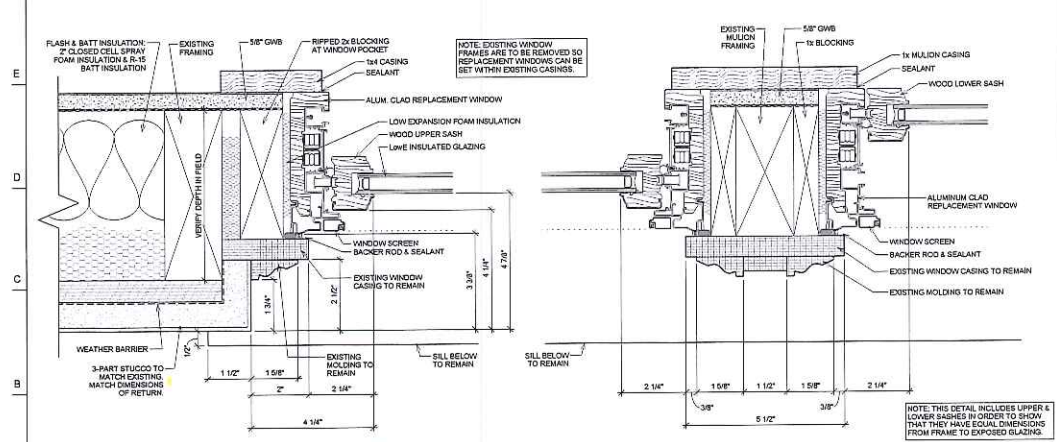

A-1 WINDOW DETAILS - ALUMINUM CLAD JAMB  
6" = 1'-0"

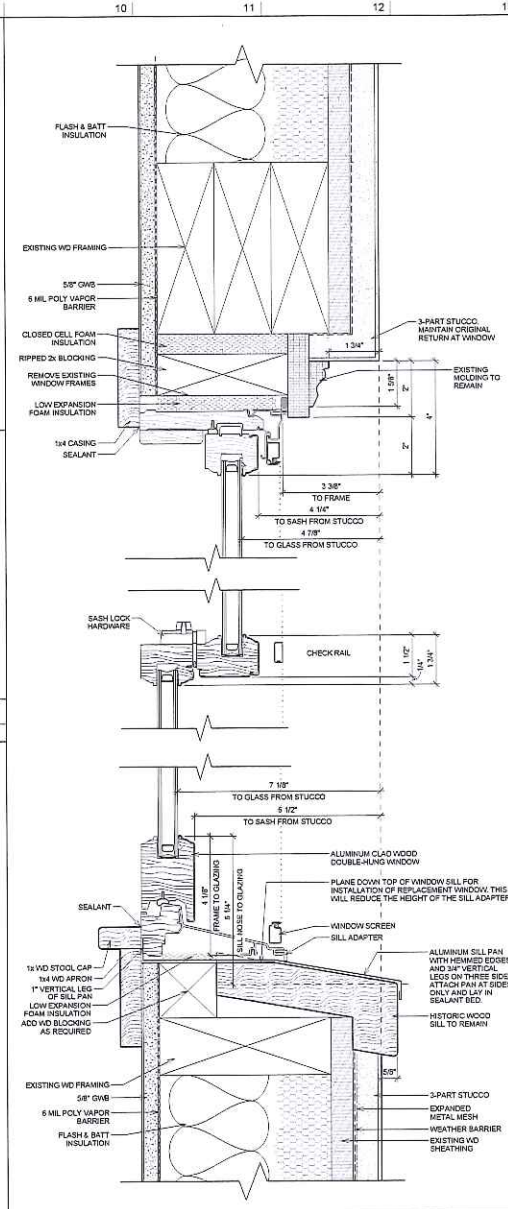

A-9 WINDOW DETAILS - ALUMINUM CLAD SECTION  
6" = 1'-0"

**NOTES**  
DO NOT SCALE DRAWINGS.

No.	REVISIONS/SUBMISSIONS	Date

245A Elm St.  
Somerville, MA 02154  
617.628.5700  
www.davis-square.com

**Consultant**

**Project** HISTORIC PRESERVATION & ADDITION  
**GATEWAY BRIGHTON**  
1954 COMMONWEALTH AVE. BOSTON, MA 02115

**Title** ALUMINUM CLAD WOOD WINDOW DETAILS

Design: BW  
Checked:  
Date: 1/19/12  
Scale: As Indicated  
Date: 2016-12-16

Drawn By: [Signature]  
Date: 1/19/12

A551

© Copyright 2016 Davis Square Architects, Inc.

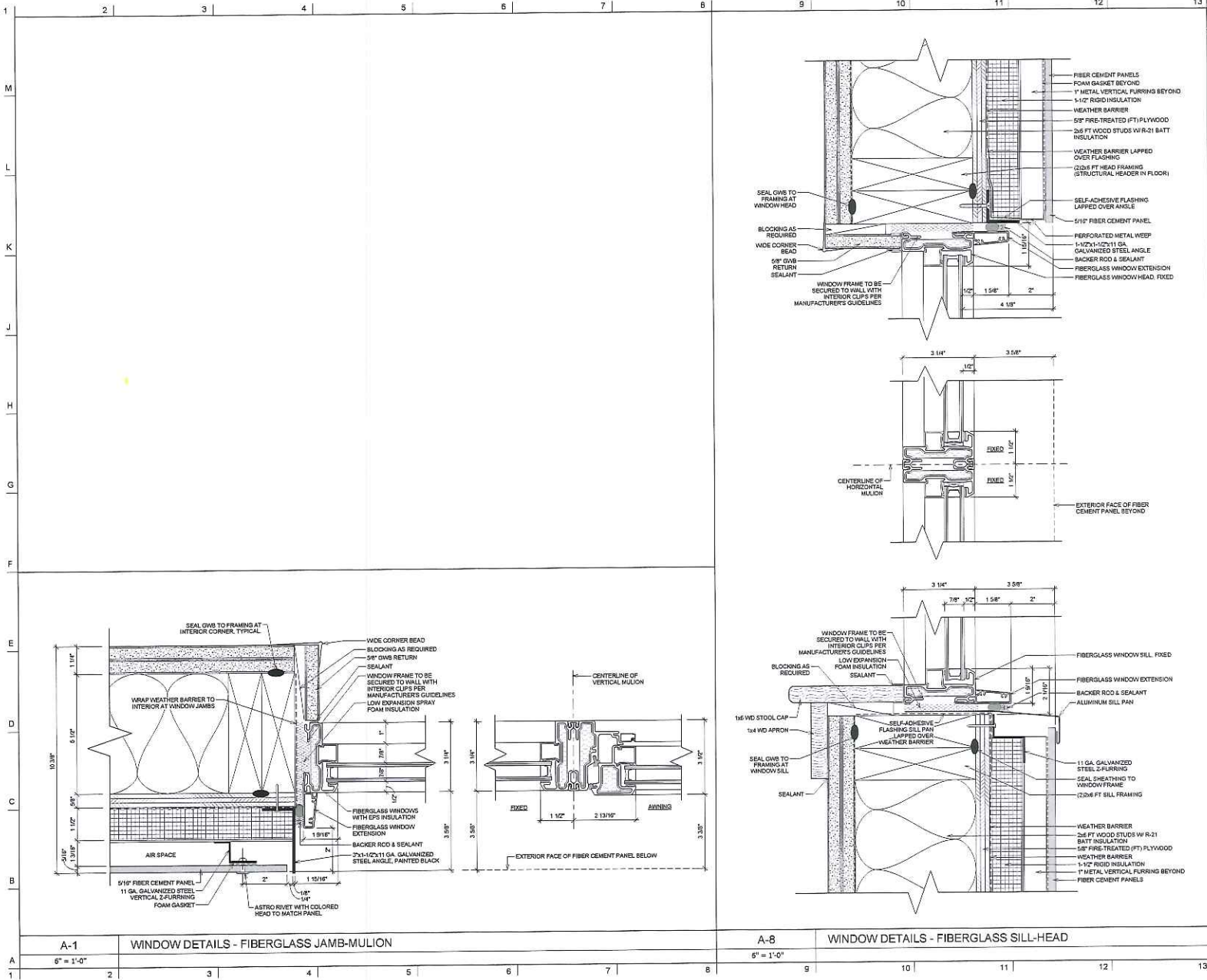

NOTES

DO NOT SCALE DRAWINGS.

No.	REVISIONS/SUBMISSIONS	Date

**DAVIS SQUARE**  
ARCHITECTS

240A Elm St.  
Somerville, MA 02144  
617.628.5700  
www.davisquarsrchitect.com

Consultant

Project: HISTORIC PRESERVATION & ADDITION  
**GATEWAY BRIGHTON**  
 1854 COMMONWEALTH AVE., BOSTON, MA 02115

Title: **FIBERGLASS WINDOW DETAILS AT FC RAINSCREEN**

Design:	BY	Drawn by:
Checked:		
Reviewed:		
Scale:	6" = 1'-0"	
Date:	2016.12.16	

A552

1 2 3 4 5 6 7 8 9 10 11 12 13

M  
L  
K  
J  
H  
G  
F  
E  
D  
C  
B

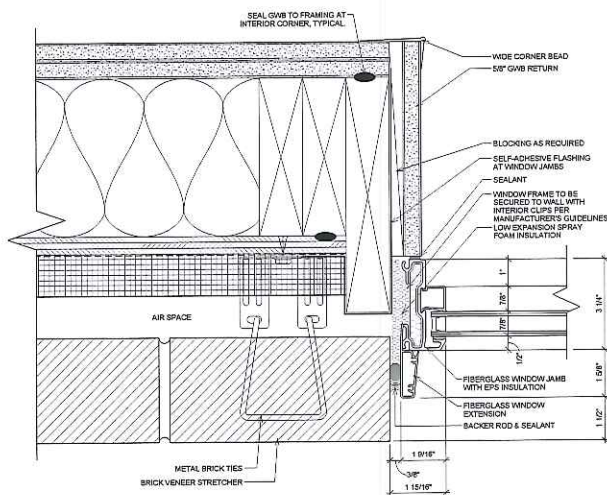

A-1 WINDOW DETAILS - BRICK JAMB  
6" = 1'-0"

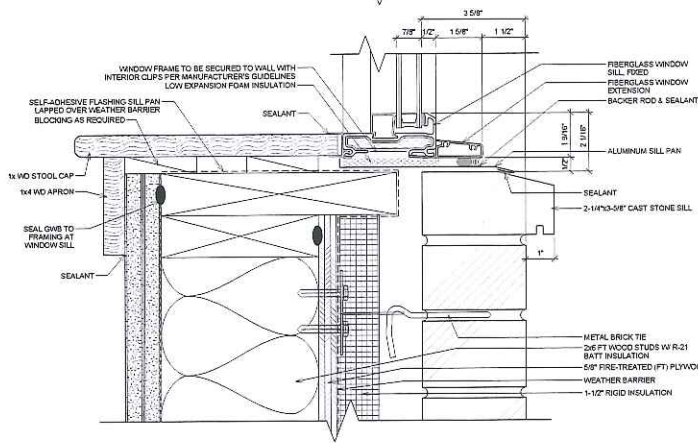
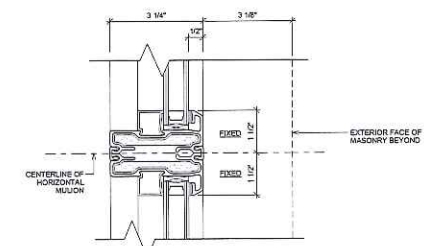
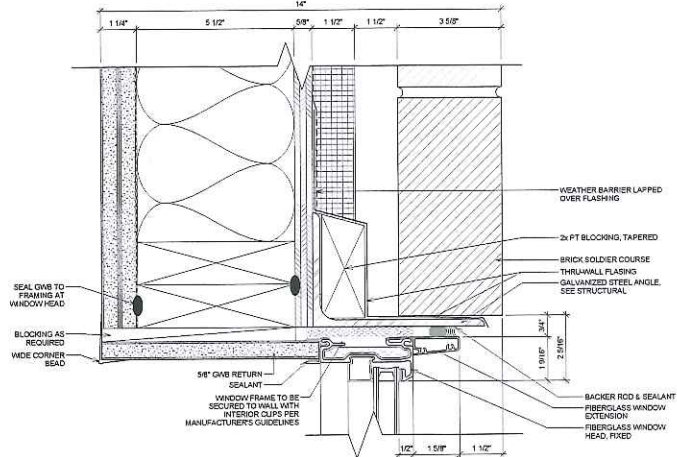

A-7 WINDOW DETAILS - BRICK SILL-HEAD  
6" = 1'-0"

**NOTES**

DO NOT SCALE DRAWINGS.

NO.	REVISIONS/SUBMISSIONS	DATE



240A Elm St.  
Somerville, MA 02144  
617.628.3700  
www.davis-square-architects.com

Consultant

Project: HISTORIC PRESERVATION & ADDITION  
GATEWAY BRIGHTON  
1554 COMMONWEALTH AVE. BOSTON, MA 02115  
Title: FIBERGLASS WINDOW DETAIL AT BRICK VENEER

Design: BW	Drawn by:
Checked: [Signature]	
Scale: 1" = 1'-0"	
Date: 2016-12-16	

**A553**

1 2 3 4 5 6 7 8 9 10 11 12 13



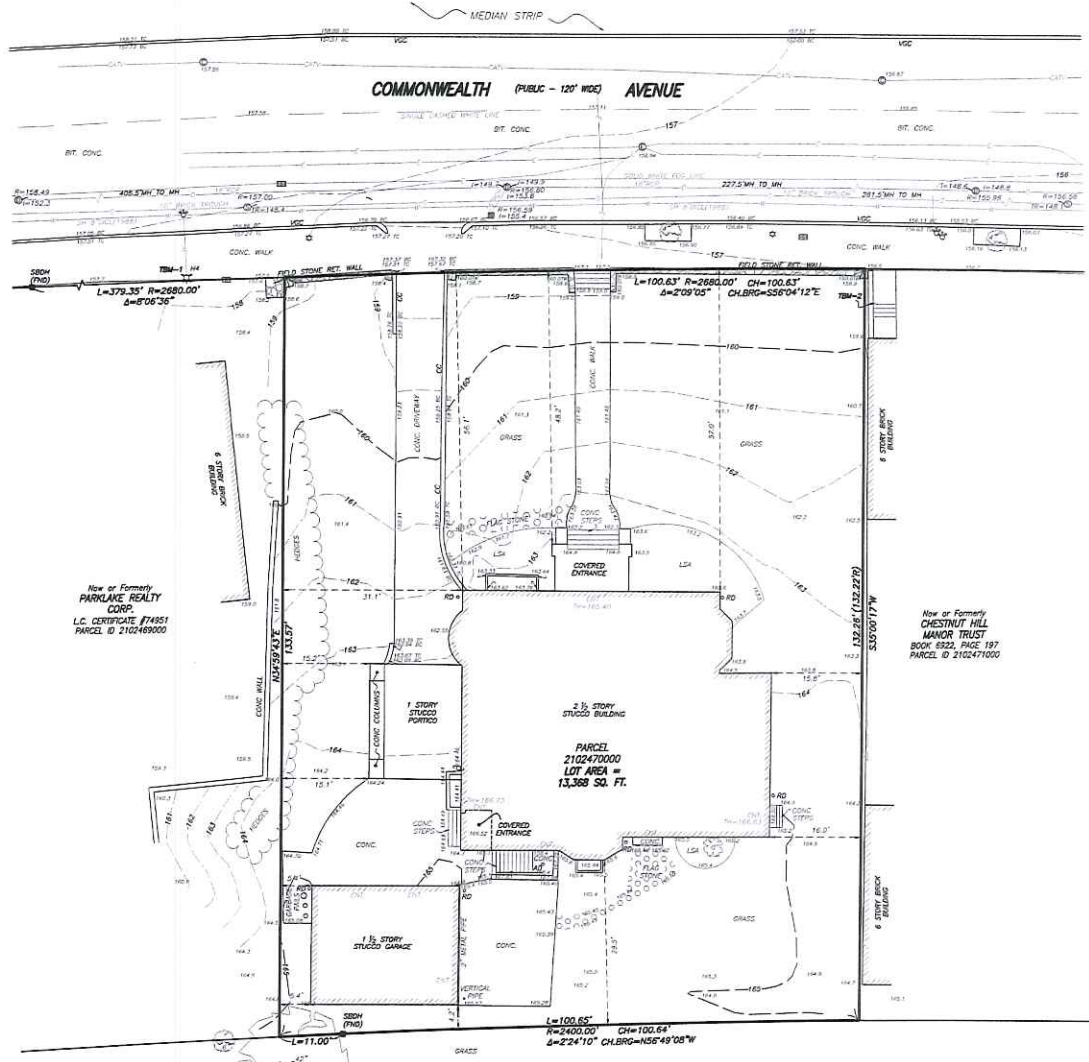

**LEGEND**

- ⊙ SEWER MANHOLE
- ⊙ DRAIN MANHOLE
- ⊙ ELECTRIC MANHOLE
- ⊙ TELEPHONE MANHOLE
- ⊙ CABLE TV MANHOLE
- ⊙ HYDRANT
- ⊙ WATER SHUT OFF
- ⊙ GAS SHUT OFF
- ⊙ BOSTON WATER VALVE
- ⊙ CATCH BASIN
- ⊙ TRAFFIC SIGNAL
- ⊙ LIGHT POLE
- ⊙ ELECTRIC HANDHOLE
- ⊙ BOLLARD
- ⊙ SIGN
- ROOF DRAIN
- CC CONCRETE CURB
- REC RECORD
- CALC CALCULATED
- VCC VERTICAL GRANITE CURB
- BIF BITUMINOUS
- CONC CONCRETE
- TC TOP OF CURB
- BC BOTTOM OF CURB
- IN INVERT ELEVATION
- TH TOP OF TRAP
- TR CENTERLINE OF TROUGH
- LSA LANDSCAPED AREA
- RET RETAINING
- WAD WOOD DRAIN
- INACC INACCESSIBLE
- SO. FT. SQUARE FEET
- RADIUS OR R/W ELEVATION
- L LENGTH
- CH.BRG+ CHORD BEARING
- CH.LEN CHORD LENGTH
- TH THRESHOLD
- TR TOP OF WALL
- S SEWER
- D DRAIN
- W WATER
- G GAS
- E ELECTRIC
- L STREET LIGHTING
- T TELEPHONE
- CTV CABLE TELEVISION

Now or Formerly  
PARKLAKE REALTY  
CORP.  
L.C. CERTIFICATE #74851  
PARCEL ID 2102469000

Now or Formerly  
CHESTNUT HILL  
MANOR TRUST  
BOOK 692, PAGE 197  
PARCEL ID 2102471000

I CERTIFY THAT THIS PLAN IS BASED ON AN ACTUAL FIELD SURVEY AND THE LATEST PLANS AND DEEDS OF RECORD.

*Karl A. McCarthy*  
KARL A. MCCARTHY, PLS (MAP 38714)  
kmm@feldmansurveyors.com

09-19-2014  
DATE



Now or Formerly  
COMMONWEALTH OF  
MASSACHUSETTS  
BOOK 5120, PAGE 425  
PARCEL ID 2102420005

**REFERENCES**

- COUNTY REGISTRY OF DEEDS  
BOOK 34320, PAGE 235
- PLAN IN BOOK 3454, PAGE 181
- PLAN IN BOOK 3360, PAGE 521
- PLAN IN BOOK 3120, PAGE 425
- MASSACHUSETTS LAND COURT  
LOC. 16350-14
- CITY OF BOSTON ENGINEERING DEPARTMENT  
FIELD BOOK 705, PAGE 47
- FIELD BOOK 741, PAGE 104
- FIELD BOOK 841, PAGE 156
- PLAN NO. L-2550

**NOTES:**

- 1) BENCH MARK INFORMATION:  
BENCH MARK USED:  
INVERT ON SEWER MANHOLE #88, ELEVATION = 148.45  
  
TEMPORARY BENCH MARKS SET:  
TBM-1, HYDRANT - LEFT FRONT CURB,  
ELEVATION = 159.61  
TBM-2, RIGHT OUTER CORNER OF TOP CONCRETE STEP,  
ELEVATION = 157.07
- 2) ELEVATIONS REFER TO BOSTON CITY BASE.
- 3) CONTOUR INTERVAL EQUALS ONE (1) FOOT.
- 4) BY GRAPHIC PLOTTING ONLY, THE PARCEL SHOWN HEREIN LIES WITHIN A ZONE "X" (UNSHADED), AN AREA OUTSIDE OF THE 0.2% ANNUAL CHANCE FLOOD, AS SHOWN ON THE FEDERAL EMERGENCY MANAGEMENT AGENCY (FEMA) FLOOD INSURANCE RATE MAP (FIRM.) FOR SUFFOLK COUNTY, MASSACHUSETTS, MAP NUMBER 250200009C, CITY OF BOSTON COMMUNITY NUMBER 250286, PANEL NUMBER 02090, HAVING AN EFFECTIVE DATE OF SEPTEMBER 25, 2009.
- 5) UTILITY INFORMATION SHOWN IS BASED ON BOTH A FIELD SURVEY AND PLANS OF RECORD. THE LOCATIONS OF UNDERGROUND PIPES AND CONDUITS HAVE BEEN DETERMINED FROM THE AFORESAID RECORD PLANS AND ARE APPROXIMATE ONLY. WE CANNOT ASSUME RESPONSIBILITY FOR DAMAGES INCURRED AS A RESULT OF UTILITIES THAT ARE OMITTED OR INACCURATELY SHOWN ON SAID RECORD PLANS, SINCE SUB-SURFACE UTILITIES CANNOT BE VISUALLY VERIFIED. BEFORE PLANNING FUTURE CONNECTIONS, THE PROPER UTILITY ENGINEERING DEPARTMENT SHOULD BE CONSULTED AND THE ACTUAL LOCATION OF SUB-SURFACE STRUCTURES SHOULD BE DETERMINED IN THE FIELD. CALL TOLL FREE, THE DIG SAFE CALL CENTER AT 1-888-344-7233 SEVENTY-TWO HOURS PRIOR TO EXCAVATION.
- 6) AT THE TIME THIS PLAN WAS PUBLISHED NO RECORD GAS INFORMATION HAD BEEN RECEIVED.
- 7) THIS DOCUMENT IS AN INSTRUMENT OF SERVICE OF FELDMAN LAND SURVEYORS ISSUED TO OUR CLIENT FOR PURPOSES RELATED DIRECTLY AND SOLELY TO FELDMAN LAND SURVEYORS' SCOPE OF SERVICES UNDER CONTRACT TO OUR CLIENT FOR THIS PROJECT. ANY USE OR REUSE OF THIS DOCUMENT FOR ANY REASON BY ANY PARTY FOR PURPOSES UNRELATED DIRECTLY AND SOLELY TO SAID CONTRACT SHALL BE AT THE USER'S SOLE AND EXCLUSIVE RISK AND LIABILITY, INCLUDING LIABILITY FOR VIOLATION OF COPYRIGHT LAWS, UNLESS WRITTEN CONSENT IS PROVIDED BY FELDMAN LAND SURVEYORS.

**EXISTING CONDITIONS PLAN**  
**1954 COMMONWEALTH AVENUE**  
**BOSTON, MASS.**

FELDMAN LAND SURVEYORS      SEPTEMBER 15, 2014  
112 SHAWMUT AVENUE      PHONE: (617)357-9740  
BOSTON, MASS. 02118      www.feldmansurveyors.com

**FELDMAN**  
LAND SURVEYORS

10 0 10 20 40  
SCALE: 1"=10'

RESEARCH	FIELD CHIEF CD	PROJ. MGR. KAM	APPROVED	SHEET NO. 1 OF 1
DATE MOD	DATE MOD	FIELD CHECKED	DRG FILE 14357	JOB NO. 14357
FILENAME: S:\PROJECTS\143506\14357\DWG\14357-02.dwg				

FIGURE 2

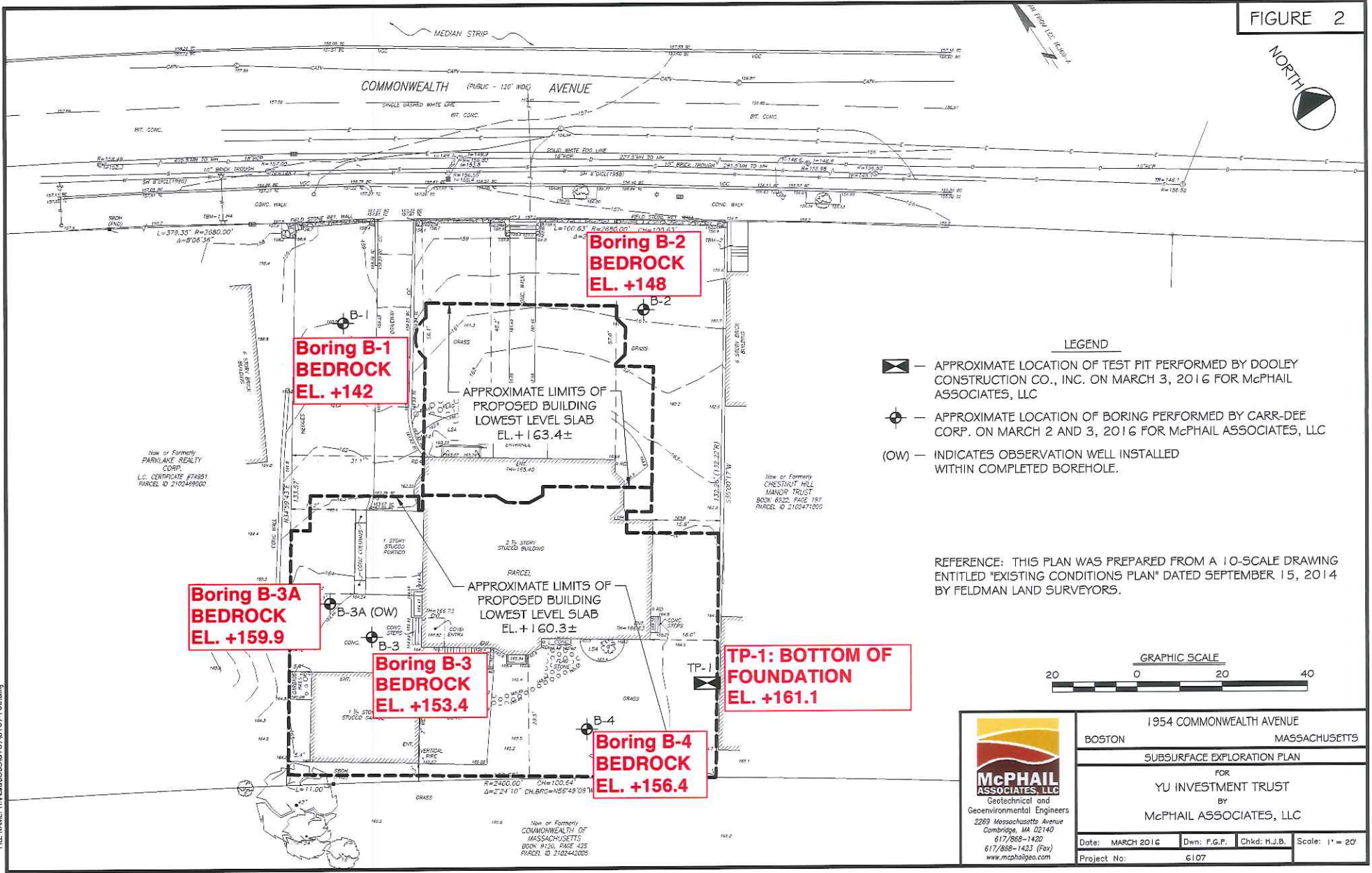

FILE NAME: H:\vca\405556 (0716) (07-F02).dwg



**DAVIS  
SQUARE**  
ARCHITECTS

240A Elm St., Somerville, MA 02144  
617.628.5700  
www.davisquarearchitects.com

Project: GATEWAY BRIGHTON

Title: Unnamed

Scale: 3/32" = 1'-0"

Project No.: 15012.00

Date: 10/15/18

Sheet No.

**A06**

© Copyright 2018 Davis Square Architects, Inc.



**DAVIS  
SQUARE**  
ARCHITECTS

240A Elm St., Somerville, MA 02144  
617.428.5700  
www.davisquarearchitects.com

Project: GATEWAY BRIGHTON

Title: WEST ELEVATION

Scale: 3/32" = 1'-0"

Project No.  
15012.00

Date  
10/15/18

Sheet No.

**A07**



**DAVIS  
SQUARE  
ARCHITECTS**

240A Elm St., Somerville, MA 02144  
617.628.5700  
www.davisquarearchitects.com

Project: GATEWAY BRIGHTON

Title: EAST ELEVATION

Scale: 3/32" = 1'-0"  
Project No: 15012.00

Date: 10/15/18

Sheet No.

**A08**

© Copyright 2018 Davis Square Architects, Inc.



**DAVIS  
SQUARE**  
ARCHITECTS

240A Elm St., Somerville, MA 02144  
617 628 5700  
www.davisquarearchitects.com

Project: GATEWAY BRIGHTON

Title: SOUTH ELEVATION

Scale: 3/32" = 1'-0"

Project No: 15012.00

Date: 10/15/18

Sheet No.

**A09**

© Copyright 2018 Davis Square Architects, Inc.



② EAST ELEVATION - EXISTING  
3/16" = 1'-0"



③ WEST ELEVATION - EXISTING  
3/16" = 1'-0"

**EXISTING ELEVATION LEGEND:**

HATCHED AREA INDICATES STUCCO THAT IS STAINED, MILDEWED OR CRACKED, AND REQUIRES REPAIR.



① NORTH ELEVATION - EXISTING  
3/16" = 1'-0"

BOSTON LANDMARK COMMISSION MEETING  
OCTOBER 20, 2016

**GATEWAY BRIGHTON**  
1954 COMMONWEALTH AVE, BOSTON, MA



**DAVIS  
SQUARE**  
ARCHITECTS

**GATEWAY BRIGHTON  
1954 COMMONWEALTH AVENUE**

---

**BOSTON, MA  
DSA PROJECT No. 15012.00**

**OUTLINE SPECIFICATION**

**DESIGN DEVELOPMENT  
October 17th, 2018**





Yu Investment Trust  
675 VFW Parkway #128  
Chestnut Hill, MA 02467

## **PROJECT SUMMARY**

The Gateway Brighton project is located at 1954 Commonwealth Avenue. The north-facing building with detached garage is located within the Arberdeen Architectural Conservation District. The rear of the property faces the Chestnut Hill Reservoir located approximately 350 feet to the south. The property is abutted by six-story masonry apartment buildings to the east and west, and across Commonwealth Avenue to the north are six-story or taller masonry apartment buildings. The proposed project is an R-2 residential apartment building with an S-2 structured parking garage at the rear of the site. There are two distinct sections of the project. The existing 2-1/2 story historic structure will be re-located to the north, moving the building toward the property's front yard, and a six-story addition will be constructed in the rear yard. The two sections will be connected through the central lobby.

Constructed in 1905, the structure is Spanish Mission-Style with stucco facades, exposed rafter tails, and a clay tile sloped roof. The historic structure is a unique element in a neighborhood surrounded by predominantly six-story masonry buildings. The addition has been designed to read as differentiated from, but complementing, the historic structure, respecting the existing building in material, form and siting, as well as the existing landscape and streetscape of which it is a part, and being sensitive to the height, scale, massing, rhythm and materials of the adjacent apartment buildings. The addition complements the existing character of the District and will be clad in materials complimenting and serving as a background to the existing building. The side-yard facades face the neighboring buildings and they have a moderate amount of fenestration. The rear yard facing the public land and reservoir has a significant amount of glass to capture the great views through the public land. The rear of the addition aligns with the rear face of the neighboring apartment buildings. The composition of the addition is influenced by the form and details of the surrounding structures. This southern façade will have Low-E coated glazing to maximize daylighting and minimize solar heat gain. The exterior walls will be insulated in the wall cavity and on the outside with continuous rigid insulation. The perimeter of exterior and demising walls will be air-sealed to provide a very energy efficient building.

## **Code Summary – Building Overview:**

Six-story residential apartment building with a basement. The building has a parking garage in a portion of the first floor, and the remainder of the space is occupied by the lobby and apartments. The building is divided into two buildings; the existing historic building is Type VB 3-story with basement, and the second building is Type IIIB with IA podium, 6-story building. The two buildings are separated by a 3-hour fire wall. The two different construction types in the second building have a horizontal 3-hour fire separation.

### **Universal Design – Massachusetts Architectural Access Board 521 CMR**

The project will provide a total of 16 apartments in the existing building and addition, so there is no requirement to provide fully accessible Group 2A units. The 13 units in the addition are served by an elevator, and therefore must comply with the Group 1 requirements. The three units in the historic section of the building are two-level townhouses so they are exempt from the Group 1 requirements.

There are 19 parking spaces, of which one space needs to be van accessible. The accessible parking space is at least eight-feet wide with a clear eight-foot side access aisle. A clear minimum ceiling height of 8 feet 2 inches is maintained from the parking garage entry to the van accessible space.

The site presents unique accessibility challenges because the grade has an approximate 6 percent slope up from the sidewalk to the rear-yard, which is an eight-foot elevation differential from front to back. There will be an accessible route from the sidewalk up to the main entry and parking level.

### **Historic Structure: Relocation/Phasing**

- Phase 1            Prep house for move and construct foundations for final location.  
                         2 to 3 months
- Phase 2            Move house onto new foundation.  
                         2 to three months
- Phase 3            Construction of addition.  
                         13 months

### **Existing Conditions Assessment:**

The existing house and detached garage are 100+ year-old structures located in the Arberdeen Architectural Conservation District on Commonwealth Avenue. The main structure is a 2-1/2 story mission style residence with stucco façade, exposed rafter tails, copper gutters and clay roof tiles. There is a detached two-car garage located to the southwest of the house that is accessed through a porte cochère that matches the style of the main house. The site is 13,368 square feet. It has a low 18-inch high stone retaining wall in the front yard adjacent to the public sidewalk at Commonwealth Avenue. The site has a gradual 6 percent slope from the front lot line to the rear lot line. The rear lot line abuts public land managed by the Department of Conservation and Recreation. The side lot lines abut adjacent apartment buildings.

The main house has a 12-inch stone masonry foundation. According to the building permit issued on May 26<sup>th</sup>, 1909, the house is a braced frame construction with 5 inch by 8 inch posts and girts. The floor timbers are 2 inch by 10 inch at 14 to 16 inches on center. The bracing is mortised, tenoned and pinned. The roof is hip framed, and the roof timbers are 2 inch by 8 inch at 16 to 19 inches on center, which are visible in the attic. The floor structure is visible in some areas of the basement, but the building is mostly finished and the structure is concealed. A building permit dated February 2, 1941 was for converting the house from a single-family to a three-family apartment building.

The exterior walls transition from the foundation to the stucco façade with a wood water table with sloped wood drip cap. The original stucco is assumed to have had a scratch coat, brown coat, and finish coat of cementitious material. The stucco is stained, mildewed and cracked, and there is evidence of multiple repairs over time that were not properly executed. These areas are indicated in the photos and drawings in the presentation. There is another horizontal water table near the second floor rimboard. Both water tables are in good shape and will be retained.

The original windows have been replaced with vinyl windows, but older photographs show that they were wood windows with divided lights. The first floor windows were 8 over 1 light, cottage style. The second floor windows were 8 over 1 light, equal sash style. The windows in the attic dormers were 6 light casement style windows. The vinyl windows, located in approximately the same location as the original, are recessed into the wall by 2.5 inches and there is a 1.75 inch brick mold at the jambs and head. The sloped wood will has a 2.75 inch exposed vertical face. The main wood and glazing entry door is 38 inches by 84 inches, with two 28 inch wide side lights. The wood door sill is deteriorated, but the remainder of the door assembly is in good condition.

The front entry portico has a masonry stone foundation, concrete steps and a concrete slab that lies 7 inches below the main entry sill. The masonry exhibits water damage and is in poor condition and needs repointing. The concrete slab and steps has cracked in some areas. The columns of the portico are tapered and finished with stucco. The roof and ceiling are wood framed with exposed rafter tails and clay roof tiles. The front gable of the portico has a curved profile with copper coping and flanking decorative globes. The copper is in poor condition and needs to be replaced.

The porte cochère has the same type of construction, wood framing with stucco on a stone foundation, as the front portico. It has similar levels of deterioration and water damage. The stucco has areas of discoloration, the roof tiles are cracked and/or missing, and the copper gutters need complete replacement. The threshold of the porte cochère is defined by a stucco arch and leads towards the detached two-car garage.

The detached two-car garage has the same construction wood framing with stucco on a stone foundation, as the main house. The stucco and clay roof tiles are in very poor condition. The garage features two arched double wood panel and six-light glazed doors. Both doors are in poor condition and are inoperable.

The roofs of the house, portico, porte cochère and garage are hip style with hipped roof dormers on the house and garage. The clay roof tiles are French low-profile interlocking tiles. Some sections of the roof have broken tiles repaired with mastic, and other areas are missing tiles that have fallen off the roof, resulting in significant water infiltration. The copper gutters and downspouts are badly damaged and require full replacement. All roofs have exposed rafter tails, and they vary in size between the main roofs, dormer roofs and the roofs of the front portico and porte cochère. These elements, as well as the wood soffit boards, will remain.

### **Relocation Feasibility Assessment:**

The General Contractor has met with the moving sub-contractor and they have determined that they will be able to re-locate the main building on the site. Wood frame buildings are light and generally not difficult for experienced building moving subcontractors. Prior to relocation the general contractor and moving subcontractor will inspect the existing structures and determine the specific requirements for the relocation and permanent details. The architect and structural engineer will also be involved in this process to determine the final construction details after relocation. Given the existing condition of the roof and stucco, the buildings may have rot associated with evident water damage that needs to be understood prior to finalizing a relocation plan.

The front portico and porte cochère will be separated from the main house, stored on site, and re-installed in the new location. The essential architectural features of the garage that are visible from the public way will be preserved in the new location. The garage doors, roof tiles and rafter tails will be salvaged and re-installed per the drawings. Elements that are deteriorated beyond repair or cannot be feasibly reinstalled, such as the stucco, will be replicated in kind.

While the main building is structurally sound, it has suffered from decades of deferred maintenance and the exterior envelope is in poor condition. The site has adequate space for the moving sub-contractor to pick the main house up and move it to the rear of the site. The new foundation will be built in the front yard, and then the existing house, front portico and porte cochère will be set on the new foundation.

The roof tiles will be removed and saved for reinstallation so the contractor can repair damaged sheathing and install a new roof underlayment. The roof tiles will be re-installed and broken/missing tiles will be replaced with tiles saved from the garage or, if there are not enough, with new tiles to match existing shape. The stucco will remain on the house during relocation, but given the existing condition there will be full replacement of the stucco finish.

## **1. GENERAL**

- 1.01 The General Contractor (GC) shall provide all labor, materials, and incidentals necessary to provide the Owner with a 100% complete project.
- 1.04 The GC shall coordinate work of all trades.
- 1.05 The GC shall provide temporary facilities and utilities.
- 1.07 The GC is responsible for supplying submittals and shop drawings for all applicable items for approval.
- 1.08 The GC is responsible for obtaining approval from the architect for substitutions of approved equal products and/or deviations from drawings.
- 1.09 The GC is responsible for verifying all dimensions in the field before ordering any materials or fabricating items.
- 1.10 The GC is responsible for salvaging all specified historic building components that are scheduled to be re-installed in the new building.
- 1.11 The GC is responsible for field measuring specific elements of the historic structure prior to demolition for the purposes of accurate replication.
- 1.12 The GC is responsible for obtaining approval from the architect for substitutions of approved equal products and/or deviations from drawings.
- 1.13 The GC shall submit a blower door test at randomly selected units at completion of construction. (10% of total units minimum).
- 1.15 The GC shall ventilate the interior spaces after substantial completion and before occupancy to dry construction and remove any accumulated VOC's.

## **2. SITEWORK**

- 2.01 SITE PREPARATION: See civil drawings and Relocation Feasibility Assessment.
- 2.02 TEMPORARY CONTROLS: Provide protection for all adjacent infrastructure.
- 2.03 SITEWORK: Excavation and backfill for foundations and utility structures. Provide all necessary shoring, bracing, and dewatering. Compacted structural fill: clean bank run gravel. Refer to site plan.
- 2.04 STORM WATER SYSTEM: Provide storm water drainage and irrigation storage system per civil engineering requirements. Work shall include segmented storage tank, drainage piping from building elements, overflow to City sewer, gravel and filter drainage areas. Includes submersible pumps as required to pump irrigation water. All roof rain leaders to be connected to on-site retainage system.

- 2.06 GRADING: Grade and clear lot to provide correct grades as determined by civil engineer.
- 2.07 PAVING OF WALKS AND STEPS: Provide new concrete walkways around edge of site leading to units. Provide new City sidewalks. Refer to site plan.
- 2.08 RETAINING WALLS: Poured in place concrete, sealed. Refer to civil, structural and architectural drawings.
- 2.09 CURBING: Provide new curbing, typical at all edges of paving. Provide 6" granite curb edging around planters.
- 2.10 BITUMINOUS PAVING: Bituminous paving with rolled-in aggregate at on-grade driveway. See civil drawings.
- 2.11 UTILITIES: Utility trenching and all new connections to tie into City utilities (water, sewer) and fuel utilities (gas, electricity) along Commonwealth Avenue. Provide all required pads, mounting and site appurtenances.
- 2.12 PLANTINGS: See landscape plan.
- 2.13 BOLLARDS: Fixed stainless steel bollard. Refer to architectural and/or civil drawings.
- 2.14 INDOOR BICYCLE STORAGE: See Specialties.
- 2.15 SITE FENCE: Gemstone Ornamental Aluminum Fencing. Opal style. See civil drawings.
- 2.16 PERMEABLE PAVERS: Paving units manufacturing from concrete that are laid in a pattern that creates large enough openings to provide infiltration laid on base course of draining aggregate material and bedding course two-inch thick layer of washed open graded free draining aggregate material, complete with edge restraint curbs and geotextile underlayment.

### **3. CONCRETE**

- 3.01 CONCRETE & FOOTINGS: See structural drawings.
- 3.02 CONCRETE PAVING AND STRIPING: 4000 psi normal weight concrete. Provide paint stripping at all parking spaces.
- 3.02 ACCESSIBLE RAMPS AND SITE STAIRS: 4000 psi normal weight concrete.
- 3.03 BUILDING SLABS: See structural drawings.
- 3.04 FOUNDATION FOOTING DRAINS AT RETAINING WALLS: See Geotechnical Drawing.

### **4. MASONRY**

- 4.01 MASONRY VENEER TYPE 1: Modular brick masonry veneer. 3 5/8" depth x 2 1/4" high x 7 5/8" length. Configuration per elevation drawings. Manufacturer to be Taylor Clay Products, Inc. Texture to be wire cut.
- 4.02 CAST STONE: Portland cement based cast masonry unit for sills, water tables and parapets per architectural drawings. Color and finishes to be selected from manufacturer's full range. Refer to architectural drawings for unit shapes and dimensions.
- 4.03 REINFORCED MASONRY: Structural shaft walls shall be constructed of reinforced masonry comprised of concrete masonry units (CMU) with vertical and horizontal reinforcing steel. Grout all block cells solid. See architectural and structural drawings.
- 4.04 INSULATED REINFORCED MASONRY: Exterior Insulated Concrete Masonry Unit walls to be Omni-Block, System 8 and 12 with an architectural finish on 1 side. See architectural and structural drawings for details.

- 4.05 STONE MASONRY: Stone veneer adhered to concrete backup. Salvage stones at new driveway opening and reinstall on wall bordering the entrance walkway. Arrange stones with color and size variations uniformly dispersed for an evenly blended appearance and concrete cap matching existing wall.

## **5. METALS**

- 5.01 EGRESS STAIR GUARDRAILS AND HANDRAILS: Guards to be 42" high 2x4 stud wall with abuse-resistant GWB. Handrails to be 1-1/2" dia. steel tube with solid brass brackets at 36" o.c., horizontally. Prime and paint.
- 5.02 UNIT STAIR GUARDRAILS AND HANDRAILS: Guards to be 42" high 2x4 stud wall with abuse-resistant GWB. Handrails to be 1-1/2" dia. oak with solid brass brackets at 36" o.c., horizontally. Stain and seal wood handrails.
- 5.03 EXTERIOR GUARDRAILS AT BALCONIES: 2"x2" steel tube guardrails, 1-1/4"x1-1/4" steel tube top rails, 3/4"x1-1/4" steel tube bottom rail, 3/4"x3/4" steel tube balusters at 4 inches on center, and 2"x2" steel tube posts. Steel to be hot-dipped galvanized.
- 5.04 EXTERIOR METAL FURRING: At the fiber cement rainscreen provide 11 gauge galvanized metal Z-girts. Horizontal Z-girts to be 1-1/2 inches deep at the continuous insulation. Vertical Z-girts to be 1 inch deep for the rainscreen air space.
- 5.05 STRUCTURAL STEEL: Provide structural steel beams, columns and other elements for building framing, including galvanized relieving angles. Refer to structural drawings.
- 5.06 STRUCTURAL STEEL: Provide structural steel hoist beam at elevators.
- 5.07 NON-STRUCTURAL METAL FRAMING: Cold-formed dimensional framing per architectural drawings at 1<sup>st</sup> floor walls.
- 5.08 METAL DECKING: 2" x 18 gauge composite galvanized steel deck structural floors per structural drawings.
- 5.09 MASONRY TIES: Provide stainless steel masonry ties per architectural drawings.
- 5.10 ROOF GUTTERS AND DOWNSPOUTS: Match the existing gutters at the historic house. Provide 6" 16oz. copper half round roof gutters at all eaves excluding dormers and port cochere. At port cochere provide 5" 16 oz. copper K-style gutter to match existing. All downspouts to be 3-1/4"x4-1/4" copper. Provide copper conductor head to match existing. Preserve copper globes at entrance.
- 5.12 GARAGE METAL SCREEN 1: Galvanized steel bar grates, painted. See architectural drawings.
- 5.14 KITCHEN BAR BRACKETS: 1/2" thick x 2-1/2" wide milled steel bracket notched into top plate of 2x4 knee-wall with four #12 wood screws. Install 24" o.c. maximum. Black powder-coat finish. Manufacturer to be centerline brackets or architect approved equal.
- 5.15 METAL PANEL CLADDING: Provide factory-finished composite metal rain screen systems with concealed fasteners and a minimum 25-year warranty. Finish to be selected by architect from manufacturer's full range. Scope and patterns as shown on architectural drawings.

## **6. WOOD AND PLASTICS**

- GENERAL: Provide wood from certified sustainably grown/harvested suppliers. Local suppliers to greatest extent practicable. **No tropical woods unless FSC certified.**

- 6.01 PRESSURE-TREATED WOOD: PT Water-Borne salt preservatives per AWPB Standards, .040 #/CF ACQ.
- 6.02 FIRE RETARDANT TREATED WOOD: To be used in exterior load bearing walls as indicated in the structural drawings.
- 6.03 WOOD STUD WALL: Spruce-Pine-Fir (SPF) No.1/No.2 wood studs at all interior walls and partitions. Provide double sills and double or triple top plate. Sills on concrete shall be pressure treated. See structural drawings.
- 6.04 EGRESS STAIRS: 2x10 landing joists, 2x12 stringers, 3/4" plywood treads/risers/landings. Integral rubber treads and risers with grit strip, and sheet rubber at landings.
- 6.05 UNIT STAIRS: 2x10 landing joists, 2x12 stringers, 3/4" plywood treads/risers/landings, and 3/4" stained red oak treads and risers. Handrails shall be 1-3/4" dia. stained red oak. See metals for brackets.
- 6.06 UNIT STAIR GUARDRAILS AND HANDRAILS: Guards to be 42" high 2x4 stud wall with abuse-resistant GWB. Handrails to be 1-1/2" dia. oak with solid brass brackets at 36" o.c., horizontally. Stain and seal wood handrails.
- 6.07 WOOD TRIM, CASINGS AND SILL AT UNIT WINDOWS: Nominal 1" poplar. Stool cap to be 1" nominal with full bullnose and cut to fit wall depth. Apron to be 1x4 nominal with 1/8" chamfer at all exposed edges. Painted. Jambs and heads to be gypsum wall board returns.
- 6.07 WOOD TRIM AT UNIT DOORS: Integral trim at split-jamb doors.
- 6.08 WALL BASE TRIM: Johnsonite Millwork Base, 1/4" x 4 1/4".
- 6.09 OPEN-WEB TRUSSES: Pre-fabricated wood floor and roof trusses as shown on the structural drawings.
- 6.10 STRUCTURAL WALL SHEATHING: Plywood wall, floor and roof sheathing as shown on the structural drawings. Sheathing at exterior walls to be fire treated 5/8" plywood.
- 6.11 BEAMS AND POSTS: Spruce-Pine-Fir (SPF) No.1/No.2, Laminated Veneer Lumber or Parallel Strand Lumber as shown on the structural drawings. (Use Fire-treated posts within exterior walls)
- 6.12 ENGINEERED JOISTS: "I" Joists shall be performance rated I joists (PRI) in accordance with APA/EWS standard. See structural drawings for sizes.
- 6.13 WOOD BLOCKING: Blocking shall be provided in all unit bathrooms for the future installation of grab bars (Group 1 MAAB). Provide blocking at kitchen walls for cabinet installation, at closets for bracket installation, and at all other location indicated in the drawing set.
- 6.14 PARKING BLOCK STANDARD: 6' parking block made from recycled rubber, solid throughout. Provide lag bolts to anchor to concrete. Provide at every interior parking space.

## **7. THERMAL AND MOISTURE PROTECTION**

- 7.01 GENERAL: To the greatest extent possible, use no- or low-VOC adhesives and sealants.
- 7.02 ROOFING, FLAT: high albedo (white) single ply adhered TPO membrane roof.
- 7.03 FLASHING, ROOF: painted .032 and .040 aluminum, misc. shapes.
- 7.04 WEATHER BARRIER 1: Parex USA WeatherSeal Spray & Roll-On water resistive air barrier with vapor permeable membrane. Provide Parex USA Sheathing joint tape. Install at historic house.

- 7.05 WEATHER BARRIER 2: Tyvek Commercial Wrap, Typar MetroWrap, Benjamin Obdyke HydroGap, or approved equal at addition.
- 7.06 BELOW-GRADE FOUNDATION WATERPROOFING: Fluid-applied, single-component, elastomertid, modified polymer waterproofing membrane to be installed at all below grade concrete walls. This is applied to concrete walls of the finished basement.
- 7.07 WINDOW HEAD/SILL/JAMB FLASHING: Parex USA Sheathing joint tape for stucco system at historic house.
- 7.07 WALL INSULATION, CONTINUOUS 1: 1-1/2" rigid insulation, typical at new construction.
- 7.08 WALL INSULATION, CONTINUOUS 2: 3" rigid insulation at CMU wall with metal Z-girts for rainscreen installation at new construction.
- 7.09 WALL INSULATION, STUD CAVITIES: Fiberglass insulation, R-21 at new construction.
- 7.10 BAND JOIST INSULATION: Fiberglass insulation, R-21.
- 7.11 FLOOR INSULATION 1: Insulate below the steel beams at second floor above parking garage with R-38 batt insulation, 24" wide rolls.
- 7.12 ROOF INSULATION 1: Polyisocyanurate insulation boards entirely above deck. R-40 minimum continuous insulation, tapered for drainage. See architectural drawings.
- 7.13 ROOF INSULATION 2: Closed Cell spray foam high performance insulation, R-40 minimum. See architectural drawings.
- 7.14 UNDER-SLAB INSULATION: 2-inch rigid insulation under basement and lobby floor slabs with 1" isolation layer between slab and exterior strip footings.
- 7.15 FOUNDATION WALL INSULATION: 2" R-10 Rigid insulation & drainage board
- 7.16 ACOUSTIC INSULATION: at party walls and party ceiling/floors, common stairway walls and ceilings/floor – mineral wool insulation.
- 7.17 INTERIOR PARTITION WALL INSULATION: R-13 fiberglass batt insulation.
- 7.18 VAPOR BARRIER: 6 mil poly vapor barrier. Completed exterior envelope to be tested for air infiltration (Energy Star standards, min).
- 7.19 FIBER CEMENT RAINSCREEN: American Fiber Cement Corporation – Through color high density fiber cement panels. Cembonit – Color 1, 922 Graphite – Color 2, 911 Sand. Panels to be 5/16 inch thick. Panels to be cut to size from nominal 4 foot x 8 foot and 4 foot x 10 foot sizes. Fasteners to be exposed rivets. See Metals for furring details.
- 7.20 PVC TRIM: Dimension trim profiles indicated in drawings.
- 7.21 FIREPROOFING: At the first floor steel structure (parking garage) provide CAFCO Fendolite M-11 spray fireproofing. Provide 3 hour fire protection at all columns, girders, beams and bracing. All columns in the parking garage shall be wrapped with 3.4 lbs. galvanized expanded diamond lath to support spray fireproofing. The composite concrete deck separating the 2<sup>nd</sup> floor from the parking garage has a 2-hour rating, but a 3-hour rating is required so additional spray fireproofing is required for a 3-hour floor assembly.
- 7.22 FIRE-STOPPING: Provide UL approved fire-stopping sealants at all penetrations though rated walls, ceilings and floors.
- 7.23 GWB SEALANTS: At unit demising walls, seal GWB to framing at all sill plates, top plates, interior corners and window/door openings. Seal around all mechanical, plumbing and electrical penetrations.
- 7.24 BATHROOM SEALANTS: Provide marine grade silicone sealants.



- 7.25 EXTERIOR WINDOW/DOOR INSULATION: Low-pressure expanding foam insulation at all gaps between window/door and rough opening. At unit entry doors seal gap at strike plate.
- 7.26 UNIT COMPARTMENTALIZATION: Each unit shall be air-sealed at the exterior walls, demising walls, and corridor walls for energy efficiency. Sealant/chalking shall be used to seal gwb and plywood to framing and for gaps less than 1/4". Expanding foam shall be used to seal gaps larger than 1/4". See architectural details.
- 7.27 FIBER-CEMENT SIDING: Provide ASTM C 1186, Type A, Grade II, fiber-cement board, noncombustible when tested according to ASTM E 136; with a flame-spread index of 25 or less when tested according to ASTM E 84.
- 7.28 EIFS: The exterior insulation and finish system (EIFS) must be a job-fabricated, drainable, exterior wall covering consisting of sheathing, air and moisture barrier, insulation board, reinforcing fabric, base coat, finish coat, adhesive and mechanical fasteners as applicable. The system components must be compatible with each other and with the substrate as recommended or approved by, and the products of, a single manufacturer regularly engaged in furnishing Exterior Insulation and Finish Systems. All materials must be installed by an applicator approved by the system manufacturer. EIFS must be Class PB color and finish to be selected by Architect from the full range of manufacturer.

## **8. DOORS AND WINDOWS**

- 8.01 ALUMINUM CLAD WOOD WINDOWS: Installed at the historic structure - custom sizing to match existing. Standard double-hung, cottage style double-hung, and casement windows to match the original configuration based on historic photographs. Windows to have insulated, argon filled, low-E glazing. 0.3 max U-value. 0.4 max SHGC. Low VOC sealants. Finishes to be selected by architect from manufacturer's full range. Standard insect screens at all operable windows. Basis-of-Design is Pella Architect Series, Deep Olive color. All operable windows shall have vinyl coated fiberglass screens, 18/16 mesh. Screen frame shall be baked enamel to match window frame color. See architectural drawings and details.
- 8.02 ADDITION WINDOWS: Installed at the addition - High efficiency picture and awning combination windows. Windows to have insulated, argon filled, low-E glazing. 0.3 max U-value. 0.4 max SHGC. Low VOC sealants. Finishes to be selected by architect from manufacturer's full range. Standard insect screens at all operable windows. Operable windows shall be limited to 4" maximum opening. Color to be Commercial Brown. Basis-of-Design is Inline fiberglass series 325, though actual will be as permitted by Commission at 1650 Commonwealth Ave or otherwise.
- 8.03 LOBBY ENTRANCE DOOR: 2-1/4" insulated aluminum full-lite door with tempered low-E glazing. Kawneer AA-425 or architect approved equal.
- 8.04 UNIT ENTRY DOORS AND FRAMES: 1-3/4", 16 gauge welded steel raised 2-panel fire rated doors in prehung frames. Painted. Manufacturer to be Delatontaine.
- 8.05 FIRE RATED DOORS/FRAMES: 16 gauge hot dipped galvanized flush doors in heavy gauge, hot dipped galv. hollow metal frame. Provide 90 min. rated doors per schedule. Typical at all stairway doors (including unit entries at common stairs), boiler room, and electrical room doors. Painted. Manufacturer to be Delatontaine.
- 8.06 INTERIOR UNIT DOORS: 1-3/8" raised 2-panel, solid-core MDF veneer, painted. Split jamb, pre-hung doors, painted. Reeb Millwork.

- 8.07 DOOR HARDWARE – GENERAL: All common doors will have key card access panels and electric strikes.
- 8.08 DOOR HARDWARE: Common Stairwell Entry Doors - lever handle lockset - Schlage mortise 'L' series 'Neptune' or approved equal with electric strike activated by card or from living unit intercom. Ball bearing hinges, accessible brass thresholds, weather-stripping, kickplate, floor door stop, ADA closer, 3" cast aluminum numbers (Ribbon font). ADA signage as required.
- 8.09 DOOR HARDWARE: Unit Entry Doors - lever handle passage latchset - Schlage mortise 'L' series 'Neptune' or approved equal, deadbolt with thumbturn, accessible aluminum thresholds, peephole, 3" cast aluminum numbers (Ribbon font), spring hinges (interior unit entry doors only).
- 8.10 DOOR HARDWARE: Interior Unit Doors - lever handle locksets (function varies) - Schlage cylinder 'D' series 'Neptune' or approved equal, standard hinges, floor door stops.
- 8.11 HISTORIC GARAGE DOORS: Shall be preserved.

## **9. FINISHES**

- 9.01 **GWB:** 5/8", Type X or Firecode C at all rated conditions, taped with three coats compound. Provide paperless, mold and moisture resistant GWB at bathrooms and laundry rooms. Refer to wall and floor/ceiling type details.
- 9.02 **FLOOR UNDERLAYMENT:** Maxxon Gycrete flooring underlayment over a parallel chord open web floor truss assembly and composite concrete decks, or approved equal at addition.
- 9.03 **ACOUSTIC UNDERLAYMENT:** Maxxon Acousti-Mat I, 1/8" sound control mat, or approved equal at historic house and addition.
- 9.04 **VINYL PLANK:** Unit living, dining, entries, hallways and kitchens. Manufacturer to be Patcraft, style Click Refresh. 7" wide by 48" long. Color to be selected by architect from manufacturer's full range.
- 9.05 **CARPET:** At unit bedrooms and bedroom closets. Masland Mesh
- 9.06 **CARPET TILE:** Mannington Social Infinity Modular. Carpet shall be urea formaldehyde free, ANSI/NSF 140 standard. Located in common hallways.
- 9.07 **WALK-OFF MAT:** At residential vestibules. Refer to architectural drawings.
- 9.08 **COMMON AREA TILE:** Residential lobby. Set on thin set with crack suppression membrane. Adko, Wood-Look Porcelain Plank Tile.
- 9.09 **UNIT TILE:** At all bathrooms, 2x4 straight-joint mosaic tile flooring and base. 3 colors selected by architect from manufacturer's full range. Daltile Modern Dimensions.
- 9.10 **STONE THRESHOLD:** Single-sloped, Carrara Marble.
- 9.11 **KITCHEN & BATH COUNTERTOP:** Dupont Zodiaq Quartz, 3 cm Course Carrara.
- 9.12 **KITCHEN BACKSPLASH:** Daltile, Reflections in Glass Tile. Install to underside of upper cabinets.
- 9.13 **RESILIENT RUBBER STAIR TREADS/RISERS:** Common area stairways. Integral rubber stair treads and riser covers with raised pattern and nosing grit strip.
- 9.14 **LOBBY WALL COVERINGS:** Decorative high-impact wall coverings at GWB walls.
- 9.15 **ACOUSTIC TILE CEILINGS AT GARAGE:** National Gypsum Gridstone Ceiling Panels. 2'x2'x1/2", gypsum core with a 2-mil white, stipple-textured vinyl laminate face. 15/16" T-bar grid.

- 9.16 PAINT: All wall and ceiling locations. Paint to be low or no- VOC latex primers and coatings. Sheen varies. Provide mildicide additives at all kitchens and bathrooms. Refer to finish schedule for paint sheen.
- 9.17 PAINT: All metals. Paint to be alkyd based, semi gloss. Galvanized metal elements to be shop primed.
- 9.18 PAINT: At exposed concrete masonry wall surfaces provide Spec-Finish, Level 1 Standard Block Finish. Color to be selected by architect from manufacturer's full range.
- 9.19 BATH SURROUNDS: Porcelain Tile. Manufacturer and style to be determined.
- 9.20 PORTLAND CEMENT STUCCO: See attached 3-part specification.

## **10. SPECIALTIES**

### **10.01 SIGNAGE:**

- Provide interior signage package including signage for all unit numbers, common areas, stairs, emergency egress directional signage, maintenance and management spaces. All interior signs to have raised letters and Braille translations.
- Contractor to provide all required construction signs and any temporary signs.

10.02 MAILBOXES: Provide USPS approved recessed ganged mailboxes with master-lock system.

10.03 INTERCOM SYSTEM: Provide wall-mounted intercom system in all units. The code required video monitoring system will be a security camera monitoring the building entry, and each tenant will be able to view through a specific channel on their television.

10.04 BUILDING NUMBERING: At exterior provide 4" high cast brass numbers. Ribbon font.

10.05 PROXIMITY CARD ACCESS SYSTEM: Key fob system at main entries.

10.06 FIRE-PROTECTION SPECIALTIES: Provide portable fire extinguishers, semi-recessed fire-protection cabinets, and mounting brackets; provide seven (7) total. Locations to be indicated on drawings. Provide one wall hung fire extinguisher near kitchen in every unit.

10.07 TOILET AND BATH ACCESSORIES: Manufacturer to be AJW. Provide mirrored medicine cabinet, 8" towel ring, 24" towel bar, toilet paper holder, robe hook, curved shower curtain rod, and 12" vertical grab bars in shower, at all unit bathrooms.

10.09 UNIT CLOSETS: Typical closet to have one fixed wire shelf and chrome finished oval rod on metal brackets at no more than 36" on center. Linen closets shall have 4 wire shelves with adjustable standards/brackets.

10.10 INDOOR BICYCLE STORAGE: Bicycle storage racks for 6 bikes in designated interior areas. Racks shall be wall mounted Bike File manufactured by Dero Bike Rack Co., or approved equal.

## **11. EQUIPMENT**

GENERAL: All appliances and equipment to be Energy Star certified.

11.01 FALL RESTRAINT EQUIPMENT: Manufacturer to be American Anchors, Guardian Fall Protection, JP Obelisk, or architect approved equal. Fixed anchor point system at flat roof. See Roof Plan.

11.02 RANGE: New 30" slide-in electric range at each kitchen except for accessible units. Smooth-top, stainless steel finish. GE Appliances.

- 11.03 MICROWAVE-OVER-THE-RANGE: 1.7 cu. ft. microwave with top vent 3-1/4"x10" exhaust. Provide transition adapter to 8" dia. Duct – see mechanical. Stainless steel finish. GE Appliances.
- 11.04 DISHWASHER – 24" wide, stainless steel finish. GE Appliances.
- 11.05 REFRIGERATOR – 18 cu. ft. frost-free refrigerators. French-door model with freezer at the bottom and integral ice makers. GE Appliances.
- 11.06 WASHER/DRYER UNIT - Stackable washer-dryer at all units. GE Appliances.
- 11.07 TRASH CHUTE: 24" dia. 16 gauge aluminized steel. Stainless steel intake doors with electrical interlocks. Chute shall be vented 4 ft. above roof level. Provide 1/2" sprinkler head at highest intake, disinfecting equipment, sound dampers and odor control. Manufacturer to be Century Chutes or architect approved equal.

## **12. FURNISHINGS**

GENERAL: To the maximum extent possible provide cabinets, countertops, and other furnishings that are constructed using formaldehyde free adhesives and materials. **No tropical woods unless FSC certified.**

- 12.01 KITCHEN CABINETS: Metropolitan Cabinets "Elegante" slab Thermofoil Northern Contours Group D "Black Truffle" with dovetail drawers, soft-close drawers and Hafele soft close hinges at doors.
- 12.02 WINDOW TREATMENT: Mecho 5 Roller Shades. Typical at all residential unit windows.

## **13. SPECIAL CONSTRUCTION**

N/A

## **14. CONVEYING SYSTEMS**

- 14.01 ELEVATOR: Provide (1) six stop, two-door gearless traction elevators and all associated systems by Kone or approved equal. GEN2 model. Solid state controls. Elevator cab finishes to be patterned stainless steel with hang pad hooks. Elevator shall have a minimum speed of 200 ft/min with 3500 lbs. capacity. Provide control room and devices per manufacturer's specifications.

## **15.1 FIRE PROTECTION**

- 15.05 AUTOMATIC FIRE SUPPRESSION SYSTEMS: See FP Drawings.

## **15.2 PLUMBING**

- 15.21 PLUMBING – See plumbing drawings.

## **15.3 MECHANICAL**

- 15.31 BASE BID SYSTEM: See Mechanical Drawings.

## **16. ELECTRICAL**

- 16.01 ELECTRICAL SYSTEM: See Electrical Drawings.
- 16.02 EXTERIOR LIGHTING: See Site Plan Civil Drawing.

END OF SPECIFICATION

**1954 Commonwealth Avenue**

**November 2018 Design Review**

**Contractor Statements and Zoning Opinion**



2310 Washington Street  
Newton Lower Falls, MA 02462  
617.965.7300 | Cranshaw.com

August 27, 2018

Dan Yu  
Lineage Ventures LLC  
675 VFW Parkway  
Chestnut Hill, MA 02467

Re: 1954 Commonwealth Ave.  
Brighton, Ma

Dear Dan,

As requested, we reviewed the request to provide an opinion on relocating the existing residential structure at 1954 Commonwealth Ave. in Brighton.

The existing building, in our opinion, is a good project for relocation. The building is founded on a basement foundation which, with some additional perimeter excavation to provide access, will allow for the installation of the main structural support beams and hydraulic moving equipment.

Please do not hesitate to contact me with questions or if you require additional information.

Sincerely,

*Christopher J. Iannelli*

Christopher J. Iannelli  
Senior Vice President



2310 Washington Street  
Newton Lower Falls, MA 02462  
617.965.7300 | Cranshaw.com

August 21, 2018

Dan Yu  
Lineage Ventures LLC  
675 VFW Parkway  
Chestnut Hill, MA 02467

Re: 1954 Commonwealth Ave.  
Brighton, Ma

Dear Dan,

As requested, we reviewed the request to provide an opinion on relocating the detached garage at 1954 Commonwealth Ave. in Brighton.

Based on our experience moving structures, most recently at 1465 Commonwealth Ave. in Brighton, the garage is not a candidate for relocation. The shallow foundations and slab on grade will not allow for the installation of the main structural support beams and hydraulic moving equipment. The building movers require a minimum of a 4'-0" crawl space and structural wood floor framing to support, stabilize and relocate.

Please do not hesitate to contact me with questions or if you require additional information.

Sincerely,

*Christopher J. Iannelli*

Christopher J. Iannelli  
Senior Vice President

# SMITH DUGGAN

SMITH DUGGAN BUELL & RUFO LLP

101 Federal Street, Suite 1405  
Boston MA 02110-1817  
Tel 617.228.4400  
Fax 617.342.8250

Paul Alan Rufo

PRufo@SmithDuggan.com  
617.228.4401 Direct

October 17, 2018

Aberdeen Architectural Conservation  
District Commission  
c/o Boston Landmarks Commission  
Environment Department  
Boston City Hall, Room 709  
Boston, Massachusetts 02201

Re: 1954 Commonwealth Avenue, Brighton

Dear Commissioners:

This law firm represents the Yu Investment Trust through its trustees ("Trust"), which is the owner and developer of the property located at 1954 Commonwealth Avenue in Brighton ("Property"). The Trust is seeking a Certificate of Design Approval with respect to the development of the Property and has requested that this office submit a written statement to the Commission concerning the present legal status of certain zoning relief obtained by our client with respect to the property.

The City of Boston Board of Appeal approved zoning relief necessary to complete the work described in the building permit application and depicted on the plans in the case numbered BZC-29846 ("Variance"). The Massachusetts Legislature enacted the Permit Extension Act, Section 173 of Chapter 240 of the Acts of 2010, which was extended by Sections 74 and 75 of Chapter 238 of the Acts of 2012 (the "Act"). The Act automatically extended the Variance beyond its otherwise applicable expiration date. The Trust, acting through its legal counsel, also secured extensions from the Board of Appeal of its Variance and timely appealed to the Suffolk Superior Court a determination of the Commission concerning its application for a Certificate of Design Approval, which appeal remains pending.

In light of the combined effect of the application of the Act, the extensions granted by the Board of Appeal, the tolling effect of the appeal and/or the Trust's request, the Board of Appeal by decision dated February 13, 2018 (copy attached) extended the Variance to March 31, 2019. Consequently, the Variance will remain valid and in effect at least until March 31, 2019.

Very truly yours,

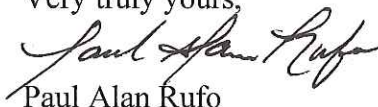

Paul Alan Rufo

Enclosure

cc: Mr. Dan Yu



# SMITH DUGGAN

SMITH DUGGAN BUELL & RUFO LLP

99 Summer Street  
Boston MA 02110-1248  
Tel 617.228.4400  
Fax 617.342.8250

Paul Alan Rufo

PRufo@SmithDuggan.com  
617.228.4401 Direct

February 7, 2018

*By Hand Delivery*

Christine Araujo, Chair  
City of Boston  
Zoning Board of Appeal  
1010 Massachusetts Avenue  
Boston, MA 02118

Re: 1954 Commonwealth Avenue, BZC-29846  
Extension of Board Decision

Dear Madam Chair:

This law firm represents Yu Investment Trust ("Trust"), the owner of the property located at 1954 Commonwealth Avenue in Brighton. We request that the Board of Appeal ("Board") place the above-captioned matter on its next available agenda in order to consider a request to extend the decision of the Board in this matter past the March 31, 2018, expiration date that currently appears on the Board's records.

By way of background, the Trust's appeal in the case numbered BZC-29846 was approved by the Board on February 9, 2010, with an entry date of the decision of March 23, 2010. The zoning relief would have expired of its own terms on March 23, 2012, but for the enactment of the Permit Extension Act, Section 173 of Chapter 240 of the Acts of 2010, as extended by Sections 74 and 75 of Chapter 238 of the Acts of 2012, as well as formal extensions granted by the Board.

The Permit Extension Act (the "Act") established an automatic four-year extension of certain permits and approvals concerning the use or development of real property, including zoning relief. With limited exceptions, the Act automatically extends, for four years beyond the otherwise applicable expiration date, any permit or approval, including zoning relief, that was in effect or existence during the qualifying period beginning on August 15, 2008, and extending through August 15, 2012.

The zoning relief granted to 1954 Commonwealth Avenue was in effect and existence during that qualifying period. Subsequently, the Trust, acting through its legal counsel at the time, by action of the Board at its hearing held on February 28, 2012, secured an extension of the zoning relief to March 31, 2013.

As a result of the application of the Act to the zoning relief granted in 2010, and the Board's action in February of 2012 (i.e., during the "qualifying period" under the Act), the zoning relief was valid and in effect through at least March 31, 2017. While the zoning relief

# SMITH-DUGGAN

Christine Araujo, Chair  
City of Boston Zoning Board of Appeal  
Re: 1954 Commonwealth Avenue  
February 7, 2018  
Page 2

was valid and in effect, the Trust sought a Certificate of Design Approval from the Boston Landmarks Commission's delegate, the Aberdeen Architectural Conservation District Commission ("Commission"), because 1954 Commonwealth Avenue is located within the Aberdeen Architectural Conservation District. By decision dated December 11, 2015, the Commission issued a Certificate of Design Approval, Conceptual Approval with Proviso. Thereafter, the Trust, acting through its legal counsel at the time, by action of the Board of Appeal at the Board's hearing held on February 28, 2017, secured an extension of the zoning relief to March 31, 2018.

After further proceedings before the Commission in late 2016 and early 2017 to satisfy the proviso, the Commission reversed its position and determined on March 9, 2017 to deny the Trust's application for a Certificate of Design Approval. The Trust timely appealed that determination to the Suffolk Superior Court pursuant to St. 1975, c. 772, §9, as amended, on April 7, 2017. Although the Trust takes the position that its appeal tolls the running of the Board's zoning relief, the Trust requests that the Board consider extending the expiration date listed on its records at its next available hearing.

Thank you for your attention to this matter.

Very truly yours,



Paul Alan Rufo

cc: Joshua L. Speicher, Esq.  
Matthew Fitzgerald, Esq.

SIGNED FEB 13 2018

  
CHRISTINE ARAUJO CHAIR

  
MARK FORTUNE SECRETARY

  
MARIE ST. FLEUR.



BRUCE BICKERSTAFF

MARK ERLICH

ANTHONY PISANI-AIA

  
CRAIG GALVIN

At its regularly scheduled hearing date of February 13, 2018 the Board of Appeal members sitting for this appeal voted to approve the extension ending March 31, 2019

  
REUSON 

## 1954 Commonwealth Avenue

### November 2018 Design Review

#### Dimensions

##### *Set Backs*

Front 20'6" to 21'4" [existing ~57']

Side East-Addition 10' 1<sup>3</sup>/<sub>8</sub>"

Side West-Addition 10' 1<sup>5</sup>/<sub>8</sub>"

Side-Garage Existing 5' 4"

Back 6' <sup>7</sup>/<sub>8</sub>" (mid.) [existing garage is 4' 8<sup>1</sup>/<sub>2</sub>"

##### *Addition Height*

66'8" (above sidewalk, excl. sloped roof and elevator overrides)

##### *Neighboring Buildings*

1950 Commonwealth 66'0" (to top of parapet above sidewalk)

1980 Commonwealth 64'0" (to top of parapet above sidewalk)

##### *Addition Height of Floors*

Typical height: 10'0" (parking level 11'8"; level two 10'9")

**1954 Commonwealth Avenue**  
**November 2018 Design Review**  
**Superior Court Legal Standard**

examination of the policy, the owner is not satisfied with it for any reason. If the owner, pursuant to such notice, surrenders the policy to the insurer by delivering it to the home office or branch office of said insurer, or to the agent through whom it was purchased, any premium paid shall be refunded and the policy shall upon such delivery be deemed void from the beginning.

SECTION 3. The provisions of sections one hundred and nineteen B and one hundred eighty-seven H of chapter one hundred and seventy-five of the General Laws, inserted by sections one and two of this act, shall apply to policies delivered or issued for delivery on or after July first, nineteen hundred and seventy-six.

*Approved December 16, 1975.*

---

**Chap. 772. AN ACT ESTABLISHING THE BOSTON LANDMARKS COMMISSION.**

*Be it enacted, etc., as follows:*

**SECTION 1. Purposes.** The purposes of this act are: (a) to protect the beauty of the city of Boston and improve the quality of its environment through identification, recognition, conservation, maintenance and enhancement of areas, sites, structures and fixtures which constitute or reflect distinctive features of the political, economic, social, cultural or architectural history of the city; (b) to foster appropriate use and wider public knowledge and appreciation of such features, areas, sites, structures, and fixtures; (c) to resist and restrain environmental influences adverse to such purposes; and (d) to encourage private efforts in support of such purposes; and (e) by furthering such purposes, to promote the public welfare, to strengthen the cultural and educational life of the city and the commonwealth and to make the city a more attractive and desirable place in which to live and work.

**SECTION 2. Definitions.** As used in this act, the following words shall have the following meanings: —

“Architectural conservation district”, any area designated by the commission in accordance with section four as an area containing any physical features or improvements or both which are of historical, social, cultural, architectural or aesthetic significance to the city and cause such area to constitute a distinctive section of the city.

“Back Bay Residential District”, the district created by section two of chapter six hundred and twenty-five of the acts of nineteen hundred and sixty-six, as it now is or hereafter may be constituted.

“Boston Redevelopment Authority”, a public body, politic and

property which is the subject of the application is not capable of earning a reasonable return. The commission shall review such evidence and make a finding as to whether substantial hardship would result from failure to issue a certificate of exemption. Notwithstanding any other provisions hereunder, the commission may postpone a final determination on the application for up to ninety days from the date of the hearing held pursuant to section six, during which time it shall endeavor to devise, in consultation with the applicant, a plan whereby, through such actions as are necessary or appropriate, the landmark or improvement may be preserved.

**SECTION 9. Appeals.** Any person aggrieved by a designation of the commission or any applicant for a certificate aggrieved by a determination pertaining to that certificate of the commission may, within thirty days next following date of such designation or determination, appeal the designation or determination to the superior court for Suffolk county.

Upon every such appeal, the court shall hear all pertinent evidence and, on the basis thereof, shall affirm the designation or determination of the commission or, if it finds the decision of the commission to be unwarranted by the evidence or to exceed the authority of the commission, or to damage the owner of the property unreasonably in comparison to the benefit conferred on the public, shall annul the designation or determination of the commission in whole or in part or remand the case for further action by the commission or make such other decree as justice and equity may require, including requiring that notice of such decision be recorded. The remedy provided by this section shall be exclusive, but the parties shall have all rights of exception and appeal as in other cases. Costs shall not be allowed against the commission or any appellant unless the court shall find that the commission's determination shall have been made, or the appellant's appeal shall have been taken in bad faith.

**SECTION 10. Enforcement.** Whoever, without the certificate required by and effective in accordance with this act, shall undertake any (i) reconstruction, restoration, exterior erection, exterior or interior replacement or alteration or demolition of any landmark or any (ii) construction, reconstruction, exterior erection, replacement or alteration or demolition with respect to any exterior architectural feature in any landmark district, architectural conservation district or protection area shall be punished by a fine of not less than fifty dollars nor more than five hundred dollars; and whoever, after having received from the commission appropriate notice to desist, shall, in violation of this act, permit any exterior architectural feature of any landmark or in any such district or area to continue to exist shall be punished by a fine of not less than fifty dollars nor more than five hundred dollars. A separate offense shall occur every day during any portion of which any such violation shall transpire.

**1954 Commonwealth Avenue**

**November 2018 Design Review**

**Existing Conditions Photos**













































**1954 Commonwealth Avenue**

**September 2018 Advisory Review Design**



**DAVIS  
SQUARE**  
ARCHITECTS

240A Elm St., Greenville, MA 02144  
617-628-5700  
www.davisquarearchitects.com

Project  
**GATEWAY BRIGHTON**

Title  
**RENDERING**

Scale  
**15012.00**

Date  
**08/17/18**

Sheet No.

**A02**

© Copyright 2018 Davis Square Architects, Inc.

**1954 Commonwealth Avenue**

**November 2018 Design Review**

**Certificate of Design Approval  
Conceptual Approval with Proviso**



# CITY OF BOSTON

## THE ENVIRONMENT DEPARTMENT

Boston City Hall, Room 709 • Boston, MA 02201 • 617/635-3850 • FAX: 617/635-3435

December 11, 2015

### ABERDEEN ARCHITECTURAL CONSERVATION DISTRICT COMMISSION

Cliff Boehmer  
Davis Square Architects  
240A Elm Street  
Somerville, MA 02144

### CERTIFICATE OF DESIGN APPROVAL CONCEPTUAL APPROVAL WITH PROVISIO

NOTICE OF DECISION  
Application 16.692 AB  
1954 Commonwealth Avenue

Dear Mr. Boehmer:

At a public hearing held at Boston City Hall on November 12, 2015 the Aberdeen Architectural Conservation District Commission reviewed your application for a Certificate of Appropriateness to move and restore the house and part of the garage at 1954 Commonwealth Avenue and to construct a six-story, 13 unit building at the rear of the property. The subject property comprises a two-story three-unit building and garage in the Mission or Craftsman style.

The Commission was receptive to the plan to relocate the house forward on the lot and build an addition behind it. They generally appreciate the massing relationship of the proposed addition, but are interested in seeing the development of the design of the addition in terms of materials and fenestration patterns. The Commission had a discussion about the plans for the garage. There were concerns that it is going to be truncated, that the roof angle will be changed and that the intention is to build a new structure that resembles the existing rather than moving the existing, and that it could be awkward in appearance. The Commissioners understood the technical difficulties involved in moving the building but agreed that keeping the front of it and some return is important, as this is a building type that is disappearing from the District and that the two buildings form a small complex that is important to retain.

*On November 12, 2015, the Aberdeen Architectural Conservation District Commission approved in concept the design presented that day, with the following proviso: (1) the applicant shall continue to work with Commission staff on retaining as much as possible of the elements of the garage.*

Additionally, with a conceptual approval, continued review by the Commission of both the proposed addition and the restoration work to the existing buildings will be required to achieve a Certificate of Design Approval.

This determination is based on documentation presented at the hearing. Statutory reviews by other agencies in conflict with this decision may affect the status of this certificate, which is valid for two years from its date of issue. The applicant is required to inform the commission of any project changes; failure to do so may affect the status of this certificate. The application is further required to consult commission staff regarding those items deferred to its further review and approval, as summarized above.

Thanking you for your anticipated cooperation,



Elizabeth A. Stifel, AIA, LEED AP BD+C  
Staff Architect, Boston Landmarks Commission

November 12, 2015 vote to approve in concept with provisos Application #16.692 AB

MOTION by Parcell; SECOND by Pillsbury  
AFFIRMATIVE: Cayley, Hoffman, Parcell, Pillsbury  
NEGATIVE: (None)

# 1954 COMMONWEALTH AVE



APPROVED IN CONCEPT W/ PROVISIONS - @ 12 NOVEMBER 2015 PH 1 of 7



Views from Commonwealth Avenue



Existing Photos

Contributing historical elements include:

- House
- Porte-cochère
- Stone Wall

# PROPOSED DESIGN Site Plan

The costly relocation of the existing house would preserve it in its entirety.

The other contributing elements of the property are also entirely preserved (portecochere and stone wall)



COB000086

APPROVED IN CONCEPT BY PRINISOS @ 12 NOVEMBER 2015 PH 3 of 7

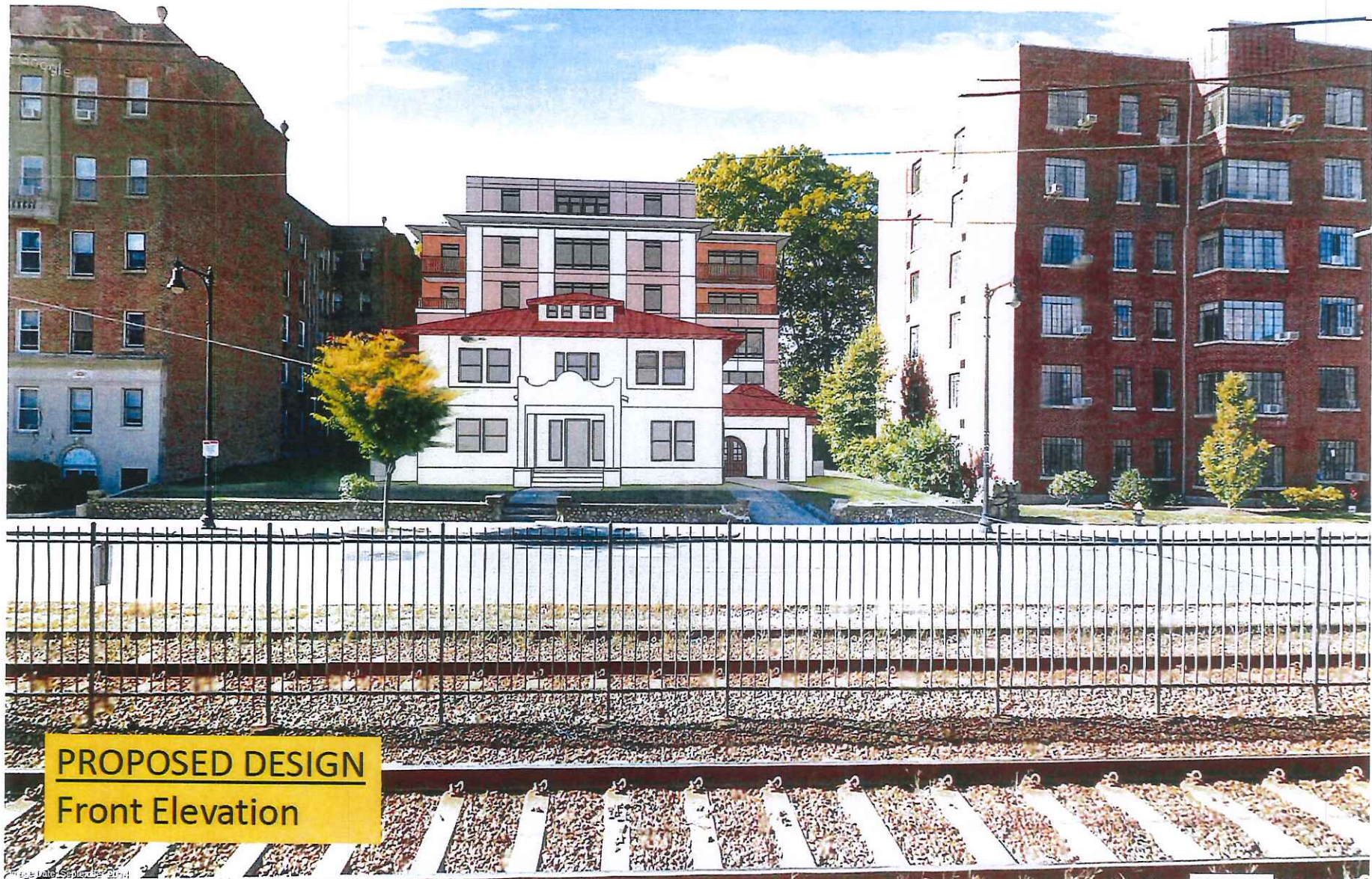

**PROPOSED DESIGN**  
**Front Elevation**

APPROVED IN CONCEPT w/ PROVISOS - @ 12 NOVEMBER 2015 P.M. 4 of 7



**PROPOSED DESIGN**  
View from Comm Ave

APPROVED IN CONCEPT BY THE BOARD OF SUPERVISORS ON 12 NOVEMBER 2015



APPROVED IN CONCEPT W/ PROVISOS @ 12 NOVEMBER 2015 PM. 6 of 7



**PROPOSED DESIGN**  
Rear Elevation

PHOTOGRAPH BY PHOTOS & FILM NOVEMBER 2015 PH 7017