



Hazen and Sawyer
498 Seventh Avenue, 11th Floor
New York, NY 10018 • 212.539.7000

July 10, 2020

Boston Conservation Commission
1 City Hall Square
Room 709
Boston, MA 02201

Re: Wetlands Notice of Intent

To Whom It May Concern:

The Massachusetts Water Resources Authority (MWRA) is proposing modifications to an existing parking lot servicing the Deer Island Public Access Area in Boston, Massachusetts (the proposed project). The proposed project includes the reconfiguration of an existing parking lot to add 11 new parking spaces to provide visitor parking to support public waterfront use at the Deer Island Public Access Area. Approximately 2,008 square feet of existing stone, gravel, and landscaped areas adjacent to the existing parking lot will be converted to public parking spaces to improve public access to waterfront areas within the Boston Harbor. One existing parking space would be removed to allow for the relocation of an existing sidewalk providing access from the parking lot to the public walkway. A leaching catch basin would be installed onsite to control stormwater runoff from the parking lot. In addition, the full 16,000 square feet of parking lot will be milled and repaved with asphalt as part of the proposed project. The modifications proposed within the parking lot would enhance the public benefits provided by the parking lot by increasing public access to the waterfront through the provision of additional parking spaces.

Hazen and Sawyer is writing on behalf of the MWRA to request an Order of Conditions for the proposed project for work within Lands Subject to Coastal Storm Flowage and work within the buffer zone for Coastal Dunes and Coastal Banks. A completed Wetlands Protection Act Form 3 is enclosed along with the required supporting information. This submission includes the following documents:

- Attachment 1 – Wetlands Protection Act Form 3
- Attachment 2 – Project Description
- Attachment 3 – Site Photographs
- Attachment 4 – Project Drawings
- Attachment 5 – Wetland Resource Area Analysis
- Attachment 6 – Stormwater Report
- Attachment 7 – List of Abutters

As always, MWRA appreciates the continued cooperation of the Boston Conservation Commission in providing an expeditious review of the enclosed documents. Should you have any questions or require additional information, please contact me at (215) 630-2513.

Job no

Very truly yours,



Joseph Buckley, PWS
Associate, Hazen and Sawyer

Enclosures.

cc: Massachusetts Department of Environmental Protection Northeast Regional Office
MWRA: R. Adams
Hazen: A. Angles, B. Levin

**ATTACHMENT 1
WETLANDS PROTECTION ACT FORM 3 AND CITY OF BOSTON
NOTICE OF INTENT APPLICATION FORM**

**Massachusetts Water Resources Authority
Deer Island Treatment Plant
Parking Lot Modifications
Boston, MA**

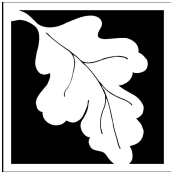

Massachusetts Department of Environmental Protection
 Bureau of Resource Protection - Wetlands
WPA Form 3 – Notice of Intent
 Massachusetts Wetlands Protection Act M.G.L. c. 131, §40

Provided by MassDEP:

MassDEP File Number

Document Transaction Number

City/Town

Important:
 When filling out forms on the computer, use only the tab key to move your cursor - do not use the return key.



Note:
 Before completing this form consult your local Conservation Commission regarding any municipal bylaw or ordinance.

A. General Information

1. Project Location (**Note:** electronic filers will click on button to locate project site):

<u>Deer Island</u>	<u>Boston</u>	<u>02128</u>
a. Street Address	b. City/Town	c. Zip Code
Latitude and Longitude:		
<u>1112</u>	<u>42°21'19.99"N</u>	<u>70°58'3.45"W</u>
f. Assessors Map/Plat Number	d. Latitude	e. Longitude
	<u>0107063000</u>	
	g. Parcel /Lot Number	

2. Applicant:

<u>Rick</u>	<u>Adams</u>	
a. First Name	b. Last Name	
<u>Massachusetts Water Resources Authority</u>		
c. Organization		
<u>Charlestown Navy Yard, 100 First Ave, Building 39</u>		
d. Street Address		
<u>Boston</u>	<u>MA</u>	<u>02129</u>
e. City/Town	f. State	g. Zip Code
<u>617-242-6000</u>	<u>richard.adams@mwra.com</u>	
h. Phone Number	i. Fax Number	j. Email Address

3. Property owner (required if different from applicant): Check if more than one owner

<u></u>	<u></u>	
a. First Name	b. Last Name	
<u></u>		
c. Organization		
<u></u>		
d. Street Address		
<u></u>	<u></u>	<u></u>
e. City/Town	f. State	g. Zip Code
<u></u>	<u></u>	<u></u>
h. Phone Number	i. Fax Number	j. Email address

4. Representative (if any):

<u>Joseph</u>	<u>Buckley</u>	
a. First Name	b. Last Name	
<u>Hazen and Sawyer</u>		
c. Company		
<u>498 7th Avenue, 11th Floor</u>		
d. Street Address		
<u>New York</u>	<u>NY</u>	<u>10018</u>
e. City/Town	f. State	g. Zip Code
<u>215-360-2513</u>	<u>jbuckley@hazenandsawyer.com</u>	
h. Phone Number	i. Fax Number	j. Email address

5. Total WPA Fee Paid (from NOI Wetland Fee Transmittal Form):

<u>\$500.00</u>	<u>\$237.50</u>	<u>\$262.50</u>
a. Total Fee Paid	b. State Fee Paid	c. City/Town Fee Paid

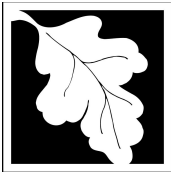

Massachusetts Department of Environmental Protection
Bureau of Resource Protection - Wetlands

WPA Form 3 – Notice of Intent

Massachusetts Wetlands Protection Act M.G.L. c. 131, §40

Provided by MassDEP:

MassDEP File Number

Document Transaction Number

City/Town

A. General Information (continued)

6. General Project Description:

The proposed project includes the reconfiguration of an existing parking lot to add 11 new parking spaces to provide visitor parking for Deer Island Public Access Area. Approximately 2,008 square feet of existing gravel and landscaped areas will be converted to public parking spaces.

7a. Project Type Checklist: (Limited Project Types see Section A. 7b.)

- 1. Single Family Home
- 2. Residential Subdivision
- 3. Commercial/Industrial
- 4. Dock/Pier
- 5. Utilities
- 6. Coastal engineering Structure
- 7. Agriculture (e.g., cranberries, forestry)
- 8. Transportation
- 9. Other

7b. Is any portion of the proposed activity eligible to be treated as a limited project (including Ecological Restoration Limited Project) subject to 310 CMR 10.24 (coastal) or 310 CMR 10.53 (inland)?

- 1. Yes No If yes, describe which limited project applies to this project. (See 310 CMR 10.24 and 10.53 for a complete list and description of limited project types)

2. Limited Project Type

If the proposed activity is eligible to be treated as an Ecological Restoration Limited Project (310 CMR10.24(8), 310 CMR 10.53(4)), complete and attach Appendix A: Ecological Restoration Limited Project Checklist and Signed Certification.

8. Property recorded at the Registry of Deeds for:

Suffolk	
a. County	b. Certificate # (if registered land)
13857	3
c. Book	d. Page Number

B. Buffer Zone & Resource Area Impacts (temporary & permanent)

- 1. Buffer Zone Only – Check if the project is located only in the Buffer Zone of a Bordering Vegetated Wetland, Inland Bank, or Coastal Resource Area.
- 2. Inland Resource Areas (see 310 CMR 10.54-10.58; if not applicable, go to Section B.3, Coastal Resource Areas).

Check all that apply below. Attach narrative and any supporting documentation describing how the project will meet all performance standards for each of the resource areas altered, including standards requiring consideration of alternative project design or location.

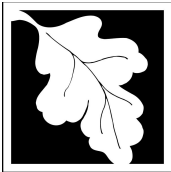

Massachusetts Department of Environmental Protection
Bureau of Resource Protection - Wetlands

WPA Form 3 – Notice of Intent

Massachusetts Wetlands Protection Act M.G.L. c. 131, §40

Provided by MassDEP:

MassDEP File Number

Document Transaction Number

City/Town

B. Buffer Zone & Resource Area Impacts (temporary & permanent) (cont'd)

For all projects affecting other Resource Areas, please attach a narrative explaining how the resource area was delineated.

<u>Resource Area</u>	<u>Size of Proposed Alteration</u>	<u>Proposed Replacement (if any)</u>
a. <input type="checkbox"/> Bank	1. linear feet _____	2. linear feet _____
b. <input type="checkbox"/> Bordering Vegetated Wetland	1. square feet _____	2. square feet _____
c. <input type="checkbox"/> Land Under Waterbodies and Waterways	1. square feet _____	2. square feet _____
	3. cubic yards dredged _____	

<u>Resource Area</u>	<u>Size of Proposed Alteration</u>	<u>Proposed Replacement (if any)</u>
d. <input type="checkbox"/> Bordering Land Subject to Flooding	1. square feet _____	2. square feet _____
	3. cubic feet of flood storage lost _____	4. cubic feet replaced _____
e. <input type="checkbox"/> Isolated Land Subject to Flooding	1. square feet _____	
	2. cubic feet of flood storage lost _____	3. cubic feet replaced _____
f. <input type="checkbox"/> Riverfront Area	1. Name of Waterway (if available) - specify coastal or inland _____	

2. Width of Riverfront Area (check one):

- 25 ft. - Designated Densely Developed Areas only
- 100 ft. - New agricultural projects only
- 200 ft. - All other projects

3. Total area of Riverfront Area on the site of the proposed project: _____ square feet

4. Proposed alteration of the Riverfront Area:

a. total square feet _____	b. square feet within 100 ft. _____	c. square feet between 100 ft. and 200 ft. _____
----------------------------	-------------------------------------	--

5. Has an alternatives analysis been done and is it attached to this NOI? Yes No

6. Was the lot where the activity is proposed created prior to August 1, 1996? Yes No

3. Coastal Resource Areas: (See 310 CMR 10.25-10.35)

Note: for coastal riverfront areas, please complete **Section B.2.f.** above.

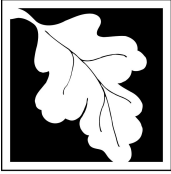

Massachusetts Department of Environmental Protection
Bureau of Resource Protection - Wetlands

WPA Form 3 – Notice of Intent

Massachusetts Wetlands Protection Act M.G.L. c. 131, §40

Provided by MassDEP:

MassDEP File Number

Document Transaction Number

City/Town

B. Buffer Zone & Resource Area Impacts (temporary & permanent) (cont'd)

Check all that apply below. Attach narrative and supporting documentation describing how the project will meet all performance standards for each of the resource areas altered, including standards requiring consideration of alternative project design or location.

Online Users:
Include your document transaction number (provided on your receipt page) with all supplementary information you submit to the Department.

<u>Resource Area</u>	<u>Size of Proposed Alteration</u>	<u>Proposed Replacement (if any)</u>
a. <input type="checkbox"/> Designated Port Areas	Indicate size under Land Under the Ocean, below	
b. <input type="checkbox"/> Land Under the Ocean	0 _____ 1. square feet	
	0 _____ 2. cubic yards dredged	
c. <input type="checkbox"/> Barrier Beach	Indicate size under Coastal Beaches and/or Coastal Dunes below	
d. <input type="checkbox"/> Coastal Beaches	0 _____ 1. square feet	0 _____ 2. cubic yards beach nourishment
e. <input type="checkbox"/> Coastal Dunes	0 _____ 1. square feet	0 _____ 2. cubic yards dune nourishment
	<u>Size of Proposed Alteration</u>	<u>Proposed Replacement (if any)</u>
f. <input type="checkbox"/> Coastal Banks	0 _____ 1. linear feet	
g. <input type="checkbox"/> Rocky Intertidal Shores	0 _____ 1. square feet	
h. <input type="checkbox"/> Salt Marshes	0 _____ 1. square feet	0 _____ 2. sq ft restoration, rehab., creation
i. <input type="checkbox"/> Land Under Salt Ponds	0 _____ 1. square feet	
	0 _____ 2. cubic yards dredged	
j. <input type="checkbox"/> Land Containing Shellfish	0 _____ 1. square feet	
k. <input type="checkbox"/> Fish Runs	Indicate size under Coastal Banks, inland Bank, Land Under the Ocean, and/or inland Land Under Waterbodies and Waterways, above	
	0 _____ 1. cubic yards dredged	
l. <input checked="" type="checkbox"/> Land Subject to Coastal Storm Flowage	2,008 _____ 1. square feet	
4. <input type="checkbox"/> Restoration/Enhancement	If the project is for the purpose of restoring or enhancing a wetland resource area in addition to the square footage that has been entered in Section B.2.b or B.3.h above, please enter the additional amount here.	
	_____	_____
	a. square feet of BVW	b. square feet of Salt Marsh
5. <input type="checkbox"/> Project Involves Stream Crossings		
	_____	_____
	a. number of new stream crossings	b. number of replacement stream crossings

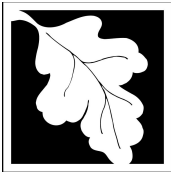

Massachusetts Department of Environmental Protection
Bureau of Resource Protection - Wetlands

WPA Form 3 – Notice of Intent

Massachusetts Wetlands Protection Act M.G.L. c. 131, §40

Provided by MassDEP:

MassDEP File Number

Document Transaction Number

City/Town

C. Other Applicable Standards and Requirements

- This is a proposal for an Ecological Restoration Limited Project. Skip Section C and complete Appendix A: Ecological Restoration Limited Project Checklists – Required Actions (310 CMR 10.11).

Streamlined Massachusetts Endangered Species Act/Wetlands Protection Act Review

1. Is any portion of the proposed project located in **Estimated Habitat of Rare Wildlife** as indicated on the most recent Estimated Habitat Map of State-Listed Rare Wetland Wildlife published by the Natural Heritage and Endangered Species Program (NHESP)? To view habitat maps, see the *Massachusetts Natural Heritage Atlas* or go to http://maps.massgis.state.ma.us/PRI_EST_HAB/viewer.htm.

- a. Yes No **If yes, include proof of mailing or hand delivery of NOI to:**

**Natural Heritage and Endangered Species Program
Division of Fisheries and Wildlife
1 Rabbit Hill Road
Westborough, MA 01581**

b. Date of map _____

If yes, the project is also subject to Massachusetts Endangered Species Act (MESA) review (321 CMR 10.18). To qualify for a streamlined, 30-day, MESA/Wetlands Protection Act review, please complete Section C.1.c, and include requested materials with this Notice of Intent (NOI); *OR* complete Section C.2.f, if applicable. *If MESA supplemental information is not included with the NOI, by completing Section 1 of this form, the NHESP will require a separate MESA filing which may take up to 90 days to review (unless noted exceptions in Section 2 apply, see below).*

- c. Submit Supplemental Information for Endangered Species Review*

1. Percentage/acreage of property to be altered:
 - (a) within wetland Resource Area _____ percentage/acreage
 - (b) outside Resource Area _____ percentage/acreage
2. Assessor's Map or right-of-way plan of site

2. Project plans for entire project site, including wetland resource areas and areas outside of wetlands jurisdiction, showing existing and proposed conditions, existing and proposed tree/vegetation clearing line, and clearly demarcated limits of work **
 - (a) Project description (including description of impacts outside of wetland resource area & buffer zone)
 - (b) Photographs representative of the site

* Some projects **not** in Estimated Habitat may be located in Priority Habitat, and require NHESP review (see <http://www.mass.gov/eea/agencies/dfg/dfw/natural-heritage/regulatory-review/>). Priority Habitat includes habitat for state-listed plants and strictly upland species not protected by the Wetlands Protection Act.

** MESA projects may not be segmented (321 CMR 10.16). The applicant must disclose full development plans even if such plans are not required as part of the Notice of Intent process.



Massachusetts Department of Environmental Protection
Bureau of Resource Protection - Wetlands

WPA Form 3 – Notice of Intent

Massachusetts Wetlands Protection Act M.G.L. c. 131, §40

Provided by MassDEP:

MassDEP File Number

Document Transaction Number

City/Town

C. Other Applicable Standards and Requirements (cont'd)

- (c) MESA filing fee (fee information available at http://www.mass.gov/dfwele/dfw/nhosp/regulatory_review/mesa/mesa_fee_schedule.htm). Make check payable to “Commonwealth of Massachusetts - NHESP” and **mail to NHESP** at above address

Projects altering 10 or more acres of land, also submit:

- (d) Vegetation cover type map of site
- (e) Project plans showing Priority & Estimated Habitat boundaries
- (f) OR Check One of the Following
1. Project is exempt from MESA review.
Attach applicant letter indicating which MESA exemption applies. (See 321 CMR 10.14, http://www.mass.gov/dfwele/dfw/nhosp/regulatory_review/mesa/mesa_exemptions.htm; the NOI must still be sent to NHESP if the project is within estimated habitat pursuant to 310 CMR 10.37 and 10.59.)
 2. Separate MESA review ongoing. a. NHESP Tracking # _____ b. Date submitted to NHESP _____
 3. Separate MESA review completed.
Include copy of NHESP “no Take” determination or valid Conservation & Management Permit with approved plan.
3. For coastal projects only, is any portion of the proposed project located below the mean high water line or in a fish run?
- a. Not applicable – project is in inland resource area only b. Yes No

If yes, include proof of mailing, hand delivery, or electronic delivery of NOI to either:

South Shore - Cohasset to Rhode Island border, and the Cape & Islands:

Division of Marine Fisheries -
Southeast Marine Fisheries Station
Attn: Environmental Reviewer
836 South Rodney French Blvd.
New Bedford, MA 02744
Email: DMF.EnvReview-South@state.ma.us

North Shore - Hull to New Hampshire border:

Division of Marine Fisheries -
North Shore Office
Attn: Environmental Reviewer
30 Emerson Avenue
Gloucester, MA 01930
Email: DMF.EnvReview-North@state.ma.us

Also if yes, the project may require a Chapter 91 license. For coastal towns in the Northeast Region, please contact MassDEP’s Boston Office. For coastal towns in the Southeast Region, please contact MassDEP’s Southeast Regional Office.

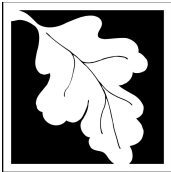

Massachusetts Department of Environmental Protection
Bureau of Resource Protection - Wetlands

WPA Form 3 – Notice of Intent

Massachusetts Wetlands Protection Act M.G.L. c. 131, §40

Provided by MassDEP:

MassDEP File Number

Document Transaction Number

City/Town

Online Users:
Include your document transaction number (provided on your receipt page) with all supplementary information you submit to the Department.

C. Other Applicable Standards and Requirements (cont'd)

- 4. Is any portion of the proposed project within an Area of Critical Environmental Concern (ACEC)?
 a. Yes No If yes, provide name of ACEC (see instructions to WPA Form 3 or MassDEP Website for ACEC locations). **Note:** electronic filers click on Website.
 b. ACEC

- 5. Is any portion of the proposed project within an area designated as an Outstanding Resource Water (ORW) as designated in the Massachusetts Surface Water Quality Standards, 314 CMR 4.00?
 a. Yes No
- 6. Is any portion of the site subject to a Wetlands Restriction Order under the Inland Wetlands Restriction Act (M.G.L. c. 131, § 40A) or the Coastal Wetlands Restriction Act (M.G.L. c. 130, § 105)?
 a. Yes No
- 7. Is this project subject to provisions of the MassDEP Stormwater Management Standards?
 a. Yes. Attach a copy of the Stormwater Report as required by the Stormwater Management Standards per 310 CMR 10.05(6)(k)-(q) and check if:
 - 1. Applying for Low Impact Development (LID) site design credits (as described in Stormwater Management Handbook Vol. 2, Chapter 3)
 - 2. A portion of the site constitutes redevelopment
 - 3. Proprietary BMPs are included in the Stormwater Management System.
 b. No. Check why the project is exempt:
 - 1. Single-family house
 - 2. Emergency road repair
 - 3. Small Residential Subdivision (less than or equal to 4 single-family houses or less than or equal to 4 units in multi-family housing project) with no discharge to Critical Areas.

D. Additional Information

- This is a proposal for an Ecological Restoration Limited Project. Skip Section D and complete Appendix A: Ecological Restoration Notice of Intent – Minimum Required Documents (310 CMR 10.12).

Applicants must include the following with this Notice of Intent (NOI). See instructions for details.

Online Users: Attach the document transaction number (provided on your receipt page) for any of the following information you submit to the Department.

- 1. USGS or other map of the area (along with a narrative description, if necessary) containing sufficient information for the Conservation Commission and the Department to locate the site. (Electronic filers may omit this item.)
- 2. Plans identifying the location of proposed activities (including activities proposed to serve as a Bordering Vegetated Wetland [BVW] replication area or other mitigating measure) relative to the boundaries of each affected resource area.

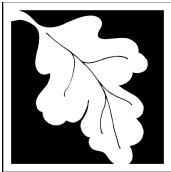

Massachusetts Department of Environmental Protection
Bureau of Resource Protection - Wetlands

WPA Form 3 – Notice of Intent

Massachusetts Wetlands Protection Act M.G.L. c. 131, §40

Provided by MassDEP:

MassDEP File Number

Document Transaction Number

City/Town

D. Additional Information (cont'd)

3. Identify the method for BVW and other resource area boundary delineations (MassDEP BVW Field Data Form(s), Determination of Applicability, Order of Resource Area Delineation, etc.), and attach documentation of the methodology.

4. List the titles and dates for all plans and other materials submitted with this NOI.

Deer Island Treatment Plant Parking Lot Modifications

a. Plan Title

Hazen and Sawyer

b. Prepared By

May 2020

d. Final Revision Date

Alberto Angles, PE

c. Signed and Stamped by

1" = 20'-0"

e. Scale

f. Additional Plan or Document Title

g. Date

5. If there is more than one property owner, please attach a list of these property owners not listed on this form.

6. Attach proof of mailing for Natural Heritage and Endangered Species Program, if needed.

7. Attach proof of mailing for Massachusetts Division of Marine Fisheries, if needed.

8. Attach NOI Wetland Fee Transmittal Form

9. Attach Stormwater Report, if needed.

E. Fees

1. Fee Exempt: No filing fee shall be assessed for projects of any city, town, county, or district of the Commonwealth, federally recognized Indian tribe housing authority, municipal housing authority, or the Massachusetts Bay Transportation Authority.

Applicants must submit the following information (in addition to pages 1 and 2 of the NOI Wetland Fee Transmittal Form) to confirm fee payment:

2. Municipal Check Number

3. Check date

4. State Check Number

5. Check date

6. Payor name on check: First Name

7. Payor name on check: Last Name



Massachusetts Department of Environmental Protection
Bureau of Resource Protection - Wetlands

WPA Form 3 – Notice of Intent

Massachusetts Wetlands Protection Act M.G.L. c. 131, §40

Provided by MassDEP:
MassDEP File Number
Document Transaction Number
City/Town

F. Signatures and Submittal Requirements

I hereby certify under the penalties of perjury that the foregoing Notice of Intent and accompanying plans, documents, and supporting data are true and complete to the best of my knowledge. I understand that the Conservation Commission will place notification of this Notice in a local newspaper at the expense of the applicant in accordance with the wetlands regulations, 310 CMR 10 05(5)(a).

I further certify under penalties of perjury that all abutters were notified of this application, pursuant to the requirements of M.G.L. c. 131, § 40. Notice must be made by Certificate of Mailing or in writing by hand delivery or certified mail (return receipt requested) to all abutters within 100 feet of the property line of the project location.

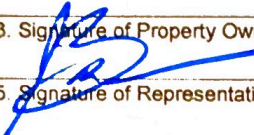
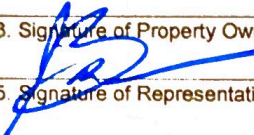
 _____ 1. Signature of Applicant	<u>7/10/20</u> _____ 2. Date
 _____ 3. Signature of Property Owner (if different)	_____ 4. Date
 _____ 5. Signature of Representative (if any)	<u>7/10/2020</u> _____ 6. Date

For Conservation Commission:

Two copies of the completed Notice of Intent (Form 3), including supporting plans and documents, two copies of the NOI Wetland Fee Transmittal Form, and the city/town fee payment, to the Conservation Commission by certified mail or hand delivery.

For MassDEP:

One copy of the completed Notice of Intent (Form 3), including supporting plans and documents, one copy of the NOI Wetland Fee Transmittal Form, and a **copy** of the state fee payment to the MassDEP Regional Office (see Instructions) by certified mail or hand delivery.

Other:

If the applicant has checked the "yes" box in any part of Section C, Item 3, above, refer to that section and the Instructions for additional submittal requirements.

The original and copies must be sent simultaneously. Failure by the applicant to send copies in a timely manner may result in dismissal of the Notice of Intent.



A. GENERAL INFORMATION

1. Project Location

<u>Deer Island</u>	<u>Boston</u>	<u>02128</u>
a. Street Address	b. City/Town	c. Zip Code
<u>1112</u>	<u>0107063000</u>	
f. Assessors Map/Plat Number	g. Parcel /Lot Number	

2. Applicant

<u>Rick</u>	<u>Adams</u>	<u>Massachusetts Water Resources Authority</u>
a. First Name	b. Last Name	c. Company
<u>Charlestown Navy Yard, 100 First Ave, Building 39</u>		
d. Mailing Address		
<u>Boston</u>	<u>MA</u>	<u>02129</u>
e. City/Town	f. State	g. Zip Code
<u>617-242-6000</u>	<u>richard.adams@mwra.com</u>	
h. Phone Number	i. Fax Number	j. Email address

3. Property Owner

<u>Rick</u>	<u>Adams</u>	<u>Massachusetts Water Resources Authority</u>
a. First Name	b. Last Name	c. Company
<u>Charlestown Navy Yard, 100 First Ave, Building 39</u>		
d. Mailing Address		
<u>Boston</u>	<u>MA</u>	<u>02129</u>
e. City/Town	f. State	g. Zip Code
<u>617-242-6000</u>	<u>richard.adams@mwra.com</u>	
h. Phone Number	i. Fax Number	j. Email address

Check if more than one owner

(If there is more than one property owner, please attach a list of these property owners to this form.)

4. Representative (if any)

<u>Joseph</u>	<u>Buckley</u>	<u>Hazen and Sawyer</u>
a. First Name	b. Last Name	c. Company
<u>498 7th Avenue, 11th Floor</u>		
d. Mailing Address		
<u>New York</u>	<u>NY</u>	<u>10018</u>
e. City/Town	f. State	g. Zip Code
<u>215-630-2513</u>	<u>jbuckley@hazenandsawyer.com</u>	
h. Phone Number	i. Fax Number	j. Email address



5. Is any portion of the proposed project jurisdictional under the Massachusetts Wetlands Protection Act M.G.L. c. 131 §40?

- Yes No

If yes, please file the WPA Form 3 - Notice of Intent with this form

6. General Information

The proposed project includes the reconfiguration of an existing parking lot to add 11 new parking spaces to provide visitor parking for Deer Island Public Access Area. Approximately 2,008 square feet of existing gravel and landscaped areas will be converted to public parking spaces.

7. Project Type Checklist

- a. Single Family Home
- b. Residential Subdivision
- c. Limited Project Driveway Crossing
- d. Commercial/Industrial
- e. Dock/Pier
- f. Utilities
- g. Coastal Engineering Structure
- h. Agriculture – cranberries, forestry
- i. Transportation
- j. Other

8. Property recorded at the Registry of Deeds

Suffolk

a. County

3

b. Page Number

13857

c. Book

d. Certificate # (if registered land)

B. BUFFER ZONE & RESOURCE AREA IMPACTS

Buffer Zone Only - Is the project located only in the Buffer Zone of a resource area protected by the Boston Wetlands Ordinance?

- Yes No

1. Coastal Resource Areas

Resource Area

- Coastal Flood Resilience Zone

Resource Area Size

Square feet

Proposed Alteration*

Square feet

Proposed Mitigation

Square feet



25-foot Waterfront Area 3,800
Square feet 44
Square feet 0
Square feet

2. Inland Resource Areas

<u>Resource Area</u>	<u>Resource Area Size</u>	<u>Proposed Alteration*</u>	<u>Proposed Mitigation</u>
<input type="checkbox"/> Inland Flood Resilience Zone	_____ Square feet	_____ Square feet	_____ Square feet
<input type="checkbox"/> Isolated Wetlands	_____ Square feet	_____ Square feet	_____ Square feet
<input type="checkbox"/> Vernal Pool	_____ Square feet	_____ Square feet	_____ Square feet
<input type="checkbox"/> Vernal Pool Habitat (vernal pool + 100 ft. upland area)	_____ Square feet	_____ Square feet	_____ Square feet
<input type="checkbox"/> 25-foot Waterfront Area	_____ Square feet	_____ Square feet	_____ Square feet

C. OTHER APPLICABLE STANDARDS & REQUIREMENTS

1. Is any portion of the proposed project located in Estimated Habitat of Rare Wildlife as indicated on the most recent Estimated Habitat Map of State-Listed Rare Wetland Wildlife published by the Natural Heritage and Endangered Species Program (NHESP)? To view habitat maps, see the Massachusetts Natural Heritage Atlas or go to <http://www.mass.gov/dfwele/dfw/nhsp/nhregmap.htm>.

Yes No

If yes, the project is subject to Massachusetts Endangered Species Act (MESA) review (321 CMR 10.18).

A. Submit Supplemental Information for Endangered Species Review

- Percentage/acreage of property to be altered:
 - (1) within wetland Resource Area _____
percentage/acreage
 - (2) outside Resource Area _____
percentage/acreage
- Assessor's Map or right-of-way plan of site

2. Is the proposed project subject to provisions of the Massachusetts Stormwater Management Yes

3. Is any portion of the proposed project within an Area of Critical Environmental Concern?

Yes No

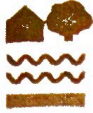

4. Is the proposed project subject to provisions of the Massachusetts Stormwater Management Standards?

- Yes. Attach a copy of the Stormwater Checklist & Stormwater Report as required.
 - Applying for a Low Impact Development (LID) site design credits
 - A portion of the site constitutes redevelopment
 - Proprietary BMPs are included in the Stormwater Management System
- No. Check below & include a narrative as to why the project is exempt
 - Single-family house
 - Emergency road repair
 - Small Residential Subdivision (less than or equal to 4 single family houses or less than or equal to 4 units in a multifamily housing projects) with no discharge to Critical Areas

5. Is the proposed project subject to Boston Water and Sewer Commission Review?

- Yes No

D. SIGNATURES AND SUBMITTAL REQUIREMENTS

I hereby certify under the penalties of perjury that the foregoing Notice of Intent and accompanying plans, documents, and supporting data are true and complete to the best of my knowledge. I understand that the Conservation Commission will place notification of this Notice in a local newspaper at the expense of the applicant in accordance with the Wetlands Protection Ordinance.



Signature of Applicant

7/10/20

Date

Signature of Property Owner (if different)

Date



Signature of Representative (if any)

7/10/2020

Date

**ATTACHMENT 2
PROJECT DESCRIPTION**

**Massachusetts Water Resources Authority
Deer Island Treatment Plant
Parking Lot Modifications
Boston, MA**

**Massachusetts Water Resources Authority
Deer Island Parking Lot Modification
Boston, MA**

PROJECT DESCRIPTION

The Massachusetts Water Resources Authority (MWRA) is proposing modifications to an existing public parking lot servicing the Deer Island Public Access Area (**Figure 1**). The proposed project includes the reconfiguration of an existing parking lot to add 11 new parking spaces to provide visitor parking for Deer Island Public Access Area. Approximately 2,008 square feet of existing stone, gravel and landscaped areas adjacent to the existing parking lot will be converted to public parking spaces to improve public access (**Attachment 3 – Photographs 1, 2, 3, and 4**). One existing parking space would be removed to allow for the relocation of an existing sidewalk providing access from the parking lot to the public walkway (**Attachment 3 – Photograph 5**). A leaching catch basin would be installed onsite to control stormwater runoff from the parking lot. In addition, the full 16,000 square feet of parking lot will be milled and repaved with asphalt as part of the proposed project.

EXISTING CONDITIONS AT THE PROPOSED PROJECT SITE

The proposed project area (the parking lot) is located on the north side of Tafts Avenue on Deer Island in Boston, Massachusetts (**Figure 1**). The parking lot currently contains 26 public parking spaces servicing the Deer Island Public Access Area which features five miles of trails for passive and active recreation. The parkland area is generally located to the southeast of the parking lot along with the Deer Island Waste Water Treatment Plant operated by the MWRA. To the northwest of the parking lot there is a privately owned property with herbaceous grasses and vegetation separated from the parking lot by a four-foot-tall metal fence (**Figure 2**).

Floodplain Designations

According to the March 16, 2016 Federal Emergency Management Agency (FEMA) Flood Insurance Rate Map (FEMA FIRM) for the Town of Boston (Community Panel 25025 C 0102J), the majority of the parking lot is within mapped flood Zone AE (el. 13, NAVD88, el. 19.46, BCB) and immediately adjacent to a VE Zone (el. 12, NAVD88, el. 18.46 BCB). Flood Zone AE (el. 13, NAVD88, el. 19.46, BCB) represents Special Flood Hazard Areas subject to inundation by the 1% annual chance flood and includes base flood elevations. Flood Zone VE (el. 12, NAVD88, el. 18.46 BCB) as mapped by FEMA, extends along the northwesterly limits of the parking lot and then turns south across the paved entrance from Tafts Avenue (**Figure 3**). Flood Zone VE is known as the coastal high hazard area, is subject to high velocity water including waves; they are defined by the 1% annual chance (base) flood limits (also known as the 100-year flood) and wave effects 3 feet or greater. The flood areas are depicted on the Existing Conditions, Demolition and Erosion and Sediment Control Plan (**Attachment 4 – Sheet C-002**) as mapped by FEMA and include labels indicating the base flood elevations in the NAVD88 datum as well as Boston City Base

datum. In addition, these plans depict the contour lines along the base flood elevations for Zones VE and AE as surveyed in Boston City Base (BCB) datum.

Wetland Protection Areas

LEC Environmental Consultants, Inc., (LEC) conducted a site evaluation and wetland resource area analysis and characterized Wetland Protection Area (WPA) boundaries in the vicinity of the parking lot. This site evaluation, a summary of which is included as **Attachment 5**, indicated the presence of Coastal Beach, Coastal Dune, Coastal Bank, and the potential presence of Barrier Beach in areas in the vicinity of the parking lot. The limits of the Coastal Dune and Coastal Banks, along with their associated 100-foot buffer areas, are depicted on the Existing Conditions, Demolition and Erosion and Sediment Control Plan (**Attachment 4 – Sheet C-002**).

In addition to the wetland resource areas mentioned above, the majority of the parking lot is within Land Subject to Coastal Storm Flowage (LSCSF) which is defined at 310 CMR 10.04 as “land subject to any inundation caused by coastal storms up to and including that caused by the 100-year storm, surge of record or storm of record, whichever is greater”. The portions of the parking lot within LSCSF are coincident with FEMA Flood Zones VE and AE and include all areas below the 19.46 foot elevation contour (BCB datum) depicted on the Existing Conditions, Demolition and Erosion and Sediment Control Plan (**Attachment 4 – Sheet C-002**).

Natural Heritage and Endangered Species Protection Areas

According to the 14th edition (August 1, 2017) of the Massachusetts Natural Heritage Atlas published by The Natural Heritage & Endangered Species Program (NHESP), the parking lot is not located within a priority habitat of rare species or estimated habitat of rare wildlife (**Figure 4**); The privately owned property to the north/northwest of the parking lot is mapped as both priority habitat of rare species (priority habitat ID 1385) and estimated habitat of rare wildlife (estimated habitat ID 1009). The proposed project does not include any work or disturbance within the priority habitat of rare species or estimated habitat of rare wildlife.

BUFFER ZONE AND RESOURCE AREA IMPACTS FROM THE PROPOSED PROJECT

The proposed project was developed to minimize disturbance to regulated buffer zone and resource areas to the maximum extent practicable.

Land Subject to Coastal Storm Flowage

The proposed project would include the construction of 11 parking spaces within LSCSF as shown on the Parking Area Site Layout (**Attachment 4 – Sheet C-003**). Approximately 2,008 square feet of existing stone, gravel and landscaped areas within LSCSF will be converted to public parking. One existing parking space would be removed to allow relocation of the existing sidewalk providing access to the public walkway within the Deer Island Public Access Area. In order to

control stormwater runoff from the parking area a leaching catch basin would be constructed immediately south of the existing bus parking area as shown on the Stormwater Infiltration System and Grading Plan (**Attachment 3 – Sheet C-004**) and Standard Details I (**Attachment 3 – Sheet C-006**). The design criteria for the stormwater infiltration system can be found in **Attachment 6 – Stormwater Report**.

Coastal Resource Area Buffer Zone

A portion of the proposed project would be completed within the 100-foot buffer areas for the Coastal Bank and Coastal Dune as shown on the Existing Conditions, Demolition and Erosion and Sediment Control Plan (**Attachment 4 – Sheet C-002**). Within the 100-foot buffer area for the Coastal Dune approximately 1,034 square feet of existing stone would be converted to public parking. Within the 100-foot buffer area for the Coastal Bank approximately 865 square feet of stone and gravel would be converted to public parking.

City of Boston Wetlands Ordinance

The proposed project includes an alteration within the 25-foot Waterfront Area regulated under the Boston Wetlands Ordinance, City of Boston Code, Ordinances, Chapter 7-1.4. An existing stone area would be converted into two parking spaces at the northwestern portion of the site. A portion of the stone area to be converted to parking is within 25-feet of the boundary of the Coastal Dune. The area to be altered within the 25-foot Waterfront Area is approximately 44 square feet.

Coastal Resource Area Performance Standards

As a portion of the proposed project is within the 100-foot buffer areas for Coastal Dune and Coastal Bank, the proposed project has been analyzed based on the performance standards listed in 310 CMR 10.28 and 10.30.

Coastal Dune (310 CMR 10.28)

- (2) *Any alteration of, or structure on, a coastal dune or within 100 feet of a coastal dune shall not have an adverse effect on the coastal dune by:*
- (a) *affecting the ability of waves to remove sand from the dune;*

Response: The proposed project includes the conversion of existing stone and landscaped areas to asphalt within the limits of the existing parking lot and is not anticipated to influence waves or wave action.

- (b) *disturbing the vegetative cover so as to destabilize the dune;*

Response: The proposed project does not include any disturbance to vegetation on or adjacent to the Coastal Dune.

- (c) *causing any modification of the dune form that would increase the potential for storm or flood damage;*

Response: The proposed project does not include any modifications to the Coastal Dune.

- (d) *interfering with the landward or lateral movement of the dune;*

Response: The proposed project includes the conversion of existing stone and landscaped areas to asphalt within the limits of the existing parking lot and is not anticipated to affect landward or lateral movement of the Coastal Dune.

- (e) *causing removal of sand from the dune artificially; or*

Response: The proposed project does not include any work within the limits of the Coastal Dune and therefore would not cause the removal of any sand from the Coastal Dune.

- (f) *interfering with mapped or otherwise identified bird nesting habitat.*

Response: While the project is adjacent to priority habitat of rare species and estimated habitat of rare wildlife the proposed project does not include any work or disturbance within this area or any otherwise identified bird nesting habitat.

- (3) *Notwithstanding the provisions of 310 CMR 10.28(3), when a building already exists upon a coastal dune, a project accessory to the existing building may be permitted, provided that such work, using the best commercially available measures, minimizes the adverse effect on the coastal dune caused by the impacts listed in 310 CMR 10.28(3)(b) through (e). Such an accessory project may include, but is not limited to, a small shed or a small parking area for residences. It shall not include coastal engineering structures.*

Response: No structures or project accessories are proposed on the Coastal Dune. All proposed work is outside of the limits of the Coastal Dune.

- (5) *The following projects may be permitted, provided that they adhere to the provisions of 310 CMR 10.28(3):*
- (a) *pedestrian walkways, designed to minimize the disturbance to the vegetative cover and traditional bird nesting habitat;*
 - (b) *fencing and other devices designed to increase dune development; and (c) plantings compatible with the natural vegetative cover.*

Response: No new fencing or pedestrian walkways are proposed within 100 feet of the Coastal Dune.

- (6) *Notwithstanding the provisions of 310 CMR 10.28(3) through (5), no project may be permitted which will have any adverse effect on specified habitat sites of Rare Species, as identified by procedures established under 310 CMR 10.37.*

Response: While the project is adjacent to priority habitat of rare species and estimated habitat of rare wildlife the proposed project does not include any work or disturbance within this area.

Coastal Bank (310 CMR 10.30)

- (2) *No new bulkhead, revetment, seawall, groin or other coastal engineering structure shall be permitted on such a coastal bank except that such a coastal engineering structure shall be permitted when required to prevent storm damage to buildings constructed prior to the effective date of 310 CMR 10.21 through 10.37 or constructed pursuant to a Notice of Intent filed prior to the effective date of 310 CMR 10.21 through 10.37 (August 10, 1978), including reconstructions of such buildings subsequent to the effective date of 310 CMR 10.21 through 10.37, provided that the following requirements are met:*
- (a) *a coastal engineering structure or a modification thereto shall be designed and constructed so as to minimize, using best available measures, adverse effects on adjacent or nearby coastal beaches due to changes in wave action, and*
 - (b) *the applicant demonstrates that no method of protecting the building other than the proposed coastal engineering structure is feasible.*
 - (c) *protective planting designed to reduce erosion may be permitted.*

Response: The proposed project does not include the construction or modification of any coastal engineering structures and the purpose of the project does not include the protection of any structures or buildings.

- (3) *Any project on a coastal bank or within 100 feet landward of the top of a coastal bank, other than a structure permitted by 310 CMR 10.30(3), shall not have an adverse effect due to wave action on the movement of sediment from the coastal bank to coastal beaches or land subject to tidal action.*

Response: The proposed project includes the conversion of existing stone and landscaped areas to parking and is not anticipated to have any effect on wave action or the movement of sediment from or to any coastal resource areas.

- (4) *The Order of Conditions and the Certificate of Compliance for any new building within 100 feet landward of the top of a coastal bank permitted by the issuing*

authority under M.G.L. c. 131, § 40 shall contain the specific condition: 310 CMR 10.30(3), promulgated under M.G.L. c. 131, § 40, requires that no coastal engineering structure, such as a bulkhead, revetment, or seawall shall be permitted on an eroding bank at any time in the future to protect the project allowed by this Order of Conditions.

Response: The proposed project does not include the construction or modification of any coastal engineering structures or buildings.

- (6) *Any project on such a coastal bank or within 100 feet landward of the top of such coastal bank shall have no adverse effects on the stability of the coastal bank.*

Response: The proposed project includes the conversion of existing stone and landscaped areas to parking within the limits of an existing parking lot and is not anticipated to have any effect on the stability of the coastal bank.

- (7) *Bulkheads, revetments, seawalls, groins or other coastal engineering structures may be permitted on such a coastal bank except when such bank is significant to storm damage prevention or flood control because it supplies sediment to coastal beaches, coastal dunes, and barrier beaches.*

Response: The proposed project does not include the construction or modification of any coastal engineering structures.

- (8) *Notwithstanding the provisions of 310 CMR 10.30(3) through (7), no project may be permitted which will have any adverse effect on specified habitat sites of rare vertebrate or invertebrate species, as identified by procedures established under 310 CMR 10.37.*

Response: While the project is adjacent to priority habitat of rare species and estimated habitat of rare wildlife the proposed project does not include any work or disturbance within this area.

ADDITIONAL MASSACHUSETTS DEPARTMENT OF ENVIRONMENTAL PROTECTION AUTHORIZATIONS

Chapter 91: Massachusetts Public Waterfront Act

The entirety of the proposed project is located within the limits of the historic high water (HHW) line (**Figure 5**). Projects within the limits of the HHW line are regulated by the Massachusetts Department of Environmental Protection (MassDEP) under 310 CMR 9.00 and therefore the project will require a minor modification to existing MassDEP License No. 2091. A request for this minor modification will be submitted to the MassDEP Division of Wetlands and Waterways under separate cover.

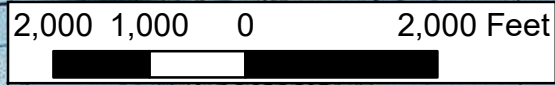
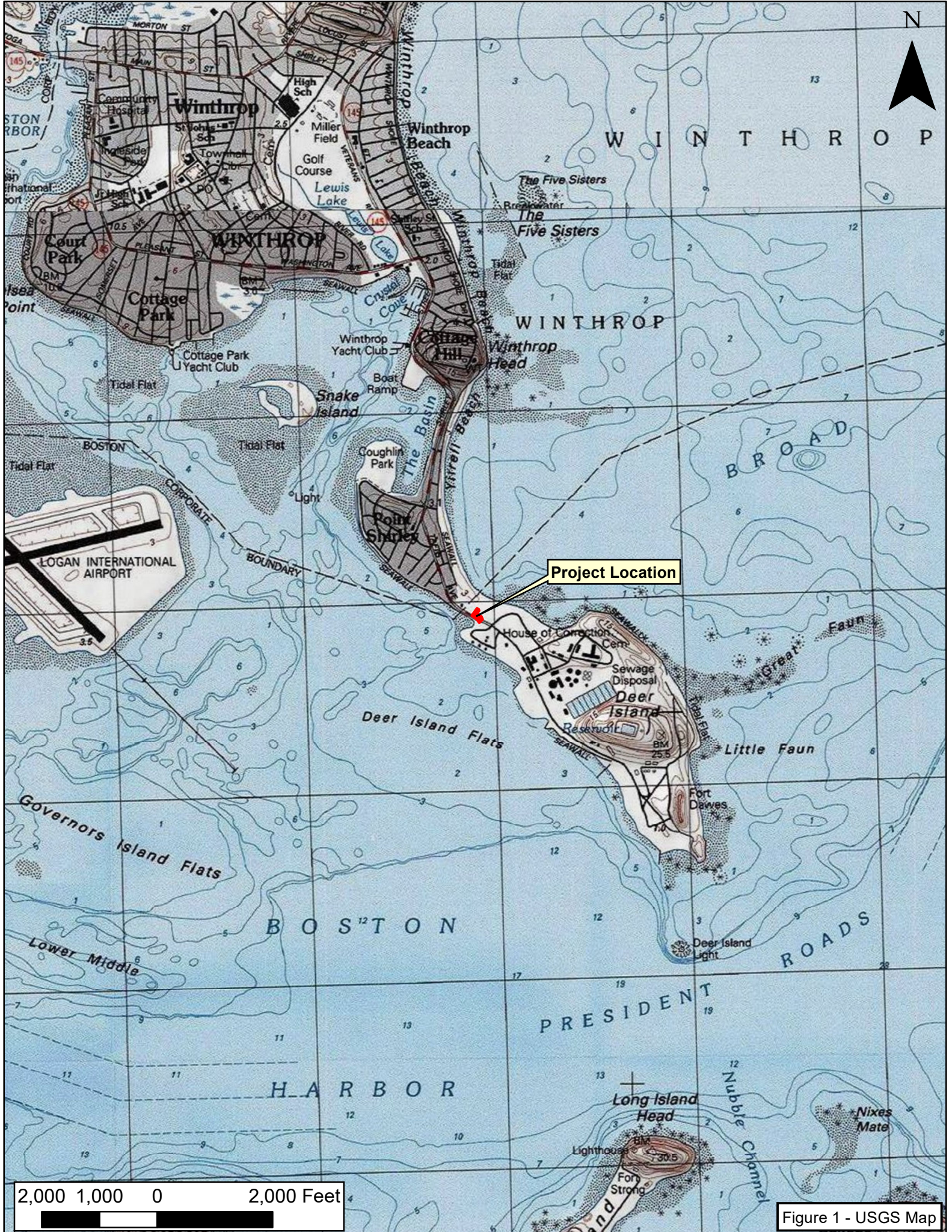

Figure 1 - USGS Map



Legend

 Site Boundary

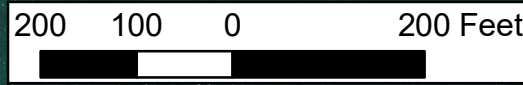

Figure 2 - Aerial Map



N

Legend

 Site Boundary

**FEMA National Flood Hazard Layer
Flood Zone Designations**

 VE: High Risk Coastal Area

 AE: 1% Annual Chance of Flooding, with BFE

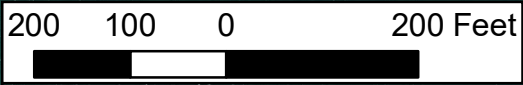

Figure 3 - FEMA Flood Hazard Area Map





EH 1009

PH 1385

N

Legend

-  Site Boundary
-  NHESP Priority Habitats of Rare Species
-  NHESP Estimated Habitats of Rare Wildlife

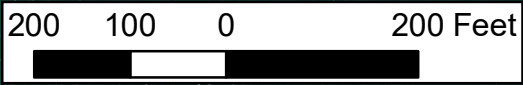



Figure 4 - NHESP Habitat Map



Legend

-  Site Boundary
-  Historic High Water Line

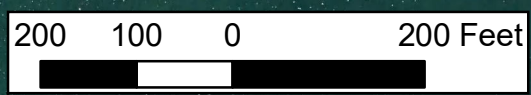

Figure 5 - Historic High Water Map

**ATTACHMENT 3
SITE PHOTOGRAPHS**

**Massachusetts Water Resources Authority
Deer Island Treatment Plant
Parking Lot Modifications
Boston, MA**



Legend
① Photograph Location and Direction

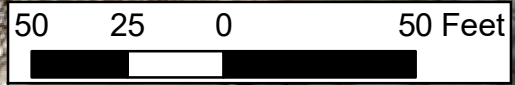

Photograph Location Map



Photograph 1. View of the entrance to the parking lot, facing northwest.



Photograph 2. View of the entrance to the parking lot and bus parking location showing the stone area, a portion of which will be converted to parking, facing southeast.



Photograph 3. View of one of the stone areas to be converted to parking, facing south.



Photograph 4. View of the landscaped area to be converted to parking and walkway to be relocated, facing northeast.



Photograph 5. View of one of the stone areas to be converted to parking and kiosk sign to be relocated, facing north.



Photograph 6. View of the existing parking spot to be removed for the relocation of the existing sidewalk, facing southeast.

**ATTACHMENT 4
PROJECT DRAWINGS**

**Massachusetts Water Resources Authority
Deer Island Treatment Plant
Parking Lot Modifications
Boston, MA**

MASSACHUSETTS WATER RESOURCES AUTHORITY

DEER ISLAND TREATMENT PLANT

PARKING LOT MODIFICATIONS
BOSTON, MA

MWRA CONTRACT NO. 7645

MAY 2020



100% SUBMISSION

Hazen

HAZEN AND SAWYER
24 FEDERAL STREET, 5TH FLOOR
BOSTON, MASSACHUSETTS 02110

FOR PERMITTING USE ONLY - NOT FOR CONSTRUCTION

PROJECT NO.	
CONTRACT NO.	7645
CAD FILE NO.	7645_T04_G-001
SHEET NO.	7645_T04_G-001

INDEX OF DRAWINGS

SHEET NO. TITLE

- GENERAL**
 7645_TO4_G-001 COVER SHEET
 7645_TO4_G-002 LOCATION PLAN AND INDEX OF DRAWINGS

- CIVIL**
 7645_TO4_C-001 CIVIL LEGEND, ABBREVIATIONS AND NOTES
 7645_TO4_C-002 EXISTING CONDITIONS, DEMOLITION AND EROSION AND SEDIMENT CONTROL PLAN
 7645_TO4_C-003 PARKING AREA SITE LAYOUT
 7645_TO4_C-004 STORMWATER INFILTRATION SYSTEM AND GRADING PLAN
 7645_TO4_C-005 FINAL SITE PLAN
 7645_TO4_C-006 STANDARD DETAILS I
 7645_TO4_C-007 STANDARD DETAILS II

- ELECTRICAL**
 7645_TO4_E-001 ELECTRICAL LEGEND, ABBREVIATIONS, NOTES, AND DETAILS
 7645_TO4_E-002 ELECTRICAL DEMOLITION
 7645_TO4_E-003 ELECTRICAL NEW WORK

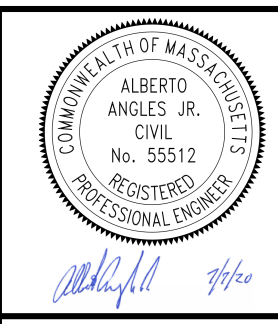
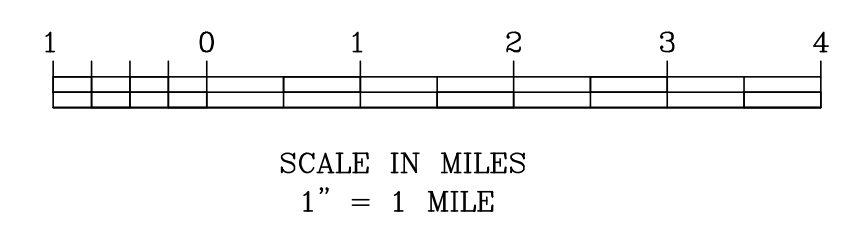
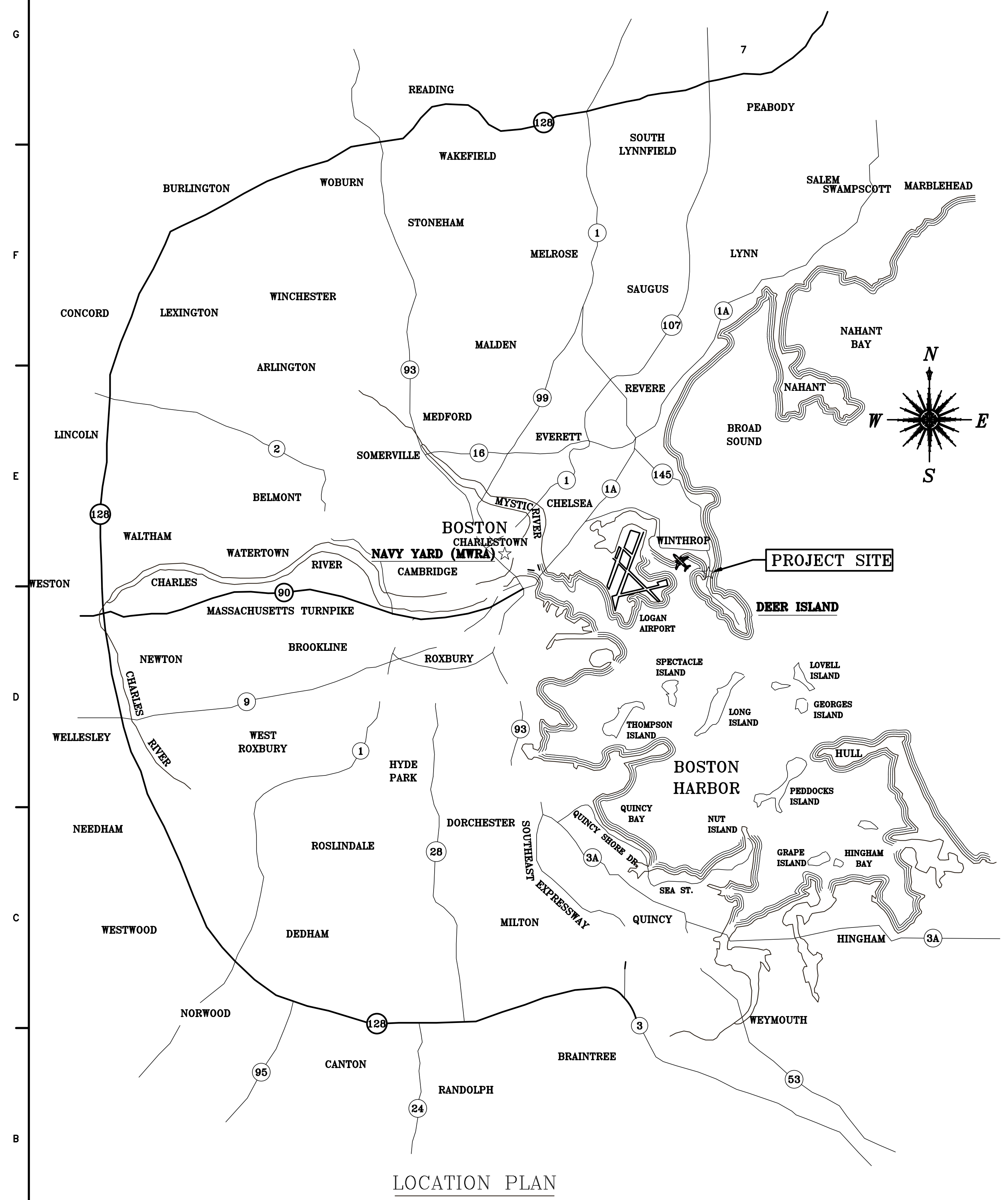
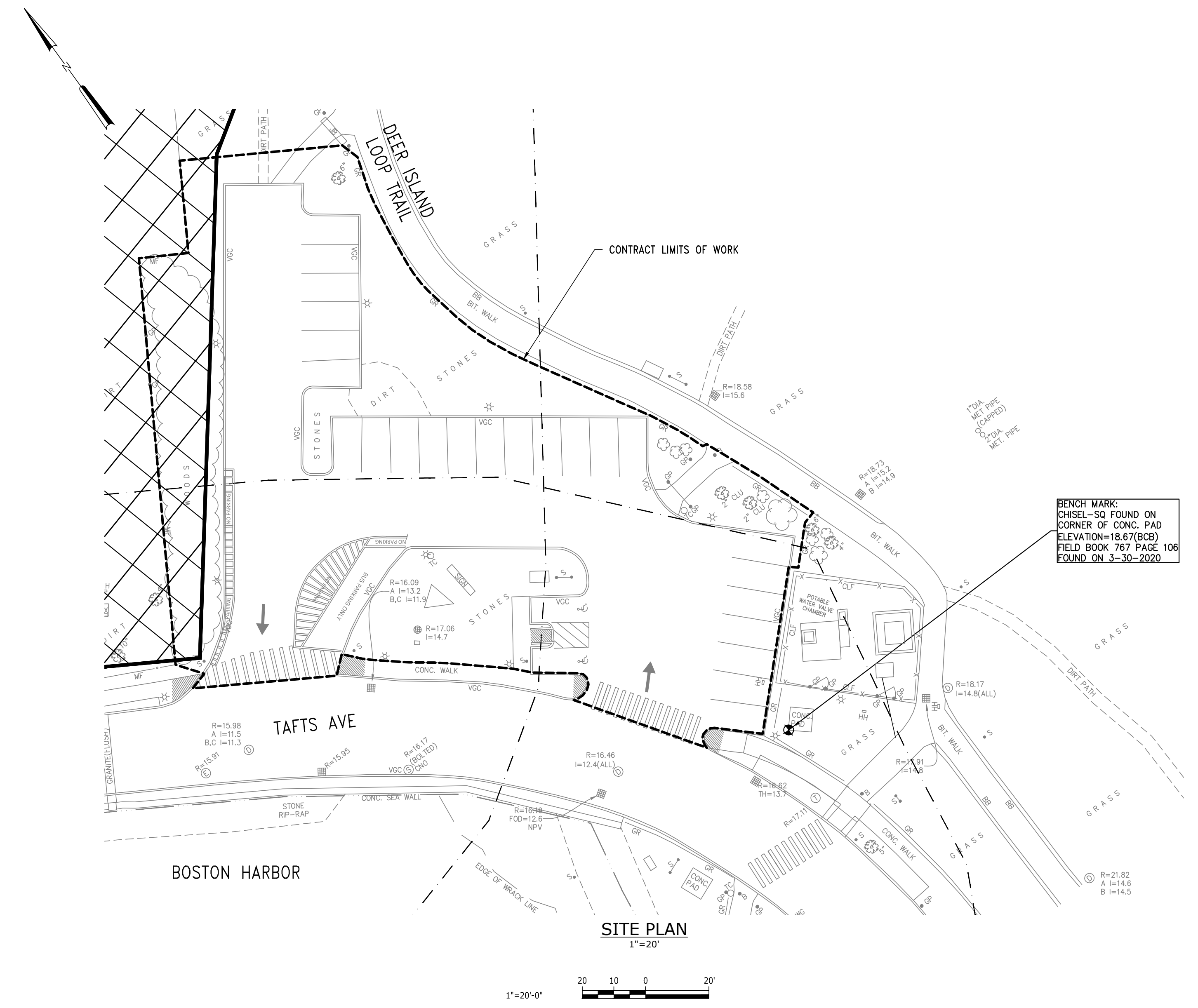

Hazen
 HAZEN AND SAWYER
 24 FEDERAL STREET, 5TH FLOOR
 BOSTON, MASSACHUSETTS 02110

SCALE: AS SHOWN
 DESIGNED BY: KTR
 DRAWN BY: KTR
 CHECKED BY: AA
 APPROVED BY: AA

NUMBER	DATE	MADE BY	CHECKED BY	DESCRIPTION

MASSACHUSETTS WATER RESOURCES AUTHORITY
 DEER ISLAND TREATMENT PLANT
PARKING LOT MODIFICATIONS
 LOCATION PLAN AND
 INDEX OF DRAWINGS

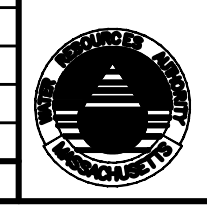

PROJECT NO. _____
 CONTRACT NO. 7645
 CAD FILE NO. 7645_TO4_G-002
 SHEET NO. 7645_TO4_G-002

CIVIL ABBREVIATIONS

ADDL	ADDITIONAL	IRR	IRRIGATION PIPE
ADJ	ADJUSTABLE	L	LENGTH/ANGLE
AGGR	AGGREGATE	LP	LIGHT POLE
AL	ALUMINUM	LF	LINEAR FEET
ALLOW	ALLOWANCE/ALLOWABLE		
ALT	ALTERNATE	MAINT	MAINTENANCE
APPROX	APPROXIMATE	MNS	MAG NAIL SET
ARCH	ARCHITECTURAL	MH	MANHOLE
ASPH	ASPHALT	MAX	MAXIMUM
		MECH	MECHANICAL
BY	BALL VALVE	MJ	MECHANICAL JOINT
BFE	BASE FLOOD ELEVATION	MDC	METROPOLITAN DISTRICT COMMISSION
BM	BENCHMARK	MIN	MINIMUM
BIT.	BITUMINOUS	MISC.	MISCELLANEOUS
BLK	BLOCK	MON	MONUMENT
BD	BOARD		
BT	BOLT	N	NORTH
B	BORING	N/A	NOT APPLICABLE
BCB	BOSTON CITY BASE	NIS	NOT TO SCALE
BC	BOTTOM OF CURB	NO.	NUMBER
BOT	BOTTOM		
BW	BOTTOM WALL ELEVATION	O.C.	ON CENTER
BLDG	BUILDING	OD	OUTSIDE DIAMETER
BL	BUILDING LINE	OF	OVERFLOW
BFV	BUTTERFLY VALVE	OHE	OVERHEAD ELECTRIC
BYP	BYPASS		
		PAR	PARALLEL
CCB	CAPE COD BERM	PVMT	PAVEMENT
C.I.	CAST IRON PIPE	PE	POLYETHYLENE/PLAIN END
CB	CATCH BASIN	PVC	POLYVINYL CHLORIDE
CEM	CEMENT	P	PROPERTY LINE
CL	CENTERLINE	PS	PUMP STATION
C/C	CENTER TO CENTER		
CLF	CHAIN LINK FENCE	QTY	QUANTITY
CLR	CLEAR		
COMB	COMBINATION	RW	RAW WATER
CONC.	CONCRETE	REF	REFERENCE
CONST	CONSTRUCTION	RC	REINFORCED CONCRETE
CONT	CONSTRUCTION EASEMENT	RCP	REINFORCED CONCRETE PIPE
CONTR	CONTRACTOR	RET.	RETAINING WALL
CF	CUBIC FEET	REQD	REQUIRED
CFS	CUBIC FEET PER SECOND	REST	RESTRAINED
CY	CUBIC YARD	RJ	RESTRAINED JOINT
		RI	RIGHT
		ROW	RIGHT OF WAY
DET	DETAIL	SAN	SANITARY
DW	DEWATERING	SS	SANITARY SEWER
DIA	DIAMETER	SCH	SCHEDULE
DBH	DIAMETER AT BREST HEIGHT	SECT	SECTION
DIM	DIMENSION	SERV	SERVICE
D	DRAIN	SEW	SEWER
DMH	DRAIN MANHOLE	SMH	SEWER MANHOLE
DWG	DRAWING	SHT	SHEET
DH	DRILL HOLE	SYL	SINGLE WHITE LINE
DYL	DOUBLE YELLOW LINE	SGC	SLOPED GRANITE CURB
DICL	DUCTILE IRON CEMENT LINED	SPEC	SPECIFICATION
DIP	DUCTILE IRON PIPE	SST	STAINLESS STEEL
		STD	STANDARD
E	EAST/EASEMENT	STA.	STATION
EA	EACH	ST	STREET
EFF	EFFLUENT	SD	STORM DRAINAGE
ELEC	ELECTRIC/ELECTRICAL	SD	STORM/SITE DRAIN
EB	ELECTRIC BARRIER	S	SOUTH/SLOPE
EMH	ELECTRIC MANHOLE	SQ	SQUARE
EL/ELEV.	ELEVATION	SF	SQUARE FEET
EOG	EDGE OF GRAVEL	SI	SQUARE INCH
EOP	EDGE OF PAVEMENT	SBL	SURVEY BASELINE
ENGR	ENGINEER		
ENT	ENTRANCE	TEL	TELEPHONE
EQ	EQUAL	TEMP	TEMPERATURE
EQPT	EQUIPMENT	TOC	TOP CURB
EXC	EXCAVATE		
EXIST.	EXISTING	TC	TOP OF CURB
EXT	EXTERIOR	TS	TRAFFIC SIGNAL MAST ARM/SPAN
		TYP.	TYPICAL
FT	FEET		
FL	FLANGE	UG	UNDERGROUND ELECTRIC
FIN	FINISH	UST	UNDERGROUND STORAGE TANK
FFE	FINISH FLOOR ELEVATION	UTIL	UTILITY
FP	FIRE PROTECTION		
FTG	FOOTING/FITTING	V	VENT
FM	FORCE MAIN	VERT	VERTICAL
FDN	FOUNDATION		
		WG	WATER GATE
G	GAS/GAS LINE	WP	WATERPROOF
GV	GATE VALVE	WV	WATER VALVE
		W	WEST/WIDTH
HDWL	HEADWALL	WCR	WHEEL CHAIR RAMP
H	HEIGHT	W	WITH
HP	HIGH POINT	W/O	WITHOUT
HORIZ	HORIZONTAL		
HYD	HYDRANT		
		YD	YARD
IN	INCH	YI	YARD INLET
INF	INFLUENT	YR	YEAR
INV	INVERT ELEVATION		

CIVIL LEGEND

PROPOSED	EXISTING	DESCRIPTION
		CATCH BASIN
		DRAIN MANHOLE
		SEWER MANHOLE
		WATER MANHOLE
		GAS GATE
		WATER GATE
		FIRE HYDRANT
		UTILITY POLE
		LIGHT POLE
		HAND HOLE
		ELECTRIC BOX
		BOLLARD
		BUSH/SHRUB
		TREE WITH TRUNK DIAMETER
		CHAIN LINK FENCE
		WROUGHT IRON FENCE
		VERTICAL GRANITE CURB
		UNDERGROUND DRAIN LINE
		UNDERGROUND ELECTRIC LINE
		UNDERGROUND GAS LINE
		UNDERGROUND WATER LINE
		OVERHEAD WIRES
		MONITORING WELL
		BENCHMARK/CONTROL POINT
		MAJOR CONTOUR
		MINOR CONTOUR
		RIM ELEVATION
		TREE LINE
		TRANSFORMER
		PEDESTRIAN SIGNAL
		TRAFFIC POLE
		SIGN
		APPROX. PROPERTY LINE
		SUBGRADE
		INLET PROTECTION
		SILT FENCE
		LIMITS OF DEMOLITION
		TREE PROTECTION FENCE
		LIMITS OF COASTAL BANK
		LIMITS OF COASTAL DUNE
		100-FT WETLAND BUFFER
		FEMA FLOOD LINE
		BFE = 19.46 BCB = 13 NAVD88
		BFE = 18.46 BCB = 12 NAVD88
		MEAN HIGH WATER
		PAVEMENT PAINT (COLOR INDICATED)
		MILLED AND OVERLAID PAVEMENT
		BITUMINOUS CONCRETE SIDEWALK
		LANDSCAPING
		STONE
		PARKING STALL COUNT
		GATE
		SPOT ELEVATION
		CURB SPOT ELEVATION
		CONTRACT LIMITS OF WORK
		CONSTRUCTION ZONE FENCE
		LEACHING CATCH BASIN
		CONCRETE APRON
		CURB CUT

CIVIL NOTES:

- HORIZONTAL INFORMATION BASED ON MASSACHUSETTS STATE PLANE COORDINATE SYSTEM (NAD1983). VERTICAL INFORMATION BASED ON BOSTON CITY BASE COORDINATE SYSTEM (BCB).
- EXISTING GROUND ELEVATIONS AND LOCATIONS OF SURFACE FEATURES SHOWN ON THESE PLANS ARE BASED ON FIELD SURVEY PERFORMED BY NITSCH ENGINEERING ON APRIL 1, 2020.
- ALL UNDERGROUND UTILITIES AS SHOWN WERE COMPILED USING FIELD SURVEY INFORMATION AND AVAILABLE RECORD INFORMATION PROVIDED BY THE AUTHORITY.
- THE ACCURACY AND COMPLETENESS OF UNDERGROUND UTILITIES AS SHOWN ON THE PLANS ARE NOT GUARANTEED. THE CONTRACTOR SHALL BE RESPONSIBLE TO DETERMINE EXACT LOCATION, SIZE, TYPE, ETC. OF ALL UNDERGROUND UTILITIES WHETHER OR NOT THEY ARE SHOWN ON THE PLANS, BEFORE ANY CONSTRUCTION COMMENCES. THE CONTRACTOR SHALL TAKE THE NECESSARY PRECAUTIONS TO PROTECT ALL UTILITIES ENCOUNTERED.
- CONTRACTOR SHALL NOTIFY DIG SAFE 72 HOURS PRIOR TO CONSTRUCTION.
- EXISTING SERVICE CONNECTIONS FOR WATER, GAS, SEWER, ELECTRICITY, TELEPHONE AND CABLE TV ARE NOT SHOWN. CONTRACTOR SHALL VERIFY ALL SERVICES AS CONSTRUCTION PROCEEDS AND MAKE NECESSARY ADJUSTMENTS INCLUDING REPLACEMENT OR RELOCATION OF SERVICES. CONTRACTOR SHALL TAKE NECESSARY PRECAUTIONS TO PROTECT ALL SERVICES DURING CONSTRUCTION ACTIVITY WITHIN THE WORK AREA AT NO ADDITIONAL COST TO THE OWNER.
- THE CONTRACTOR SHALL RESTORE ALL PAVEMENT MARKINGS, PAVEMENT, SIDEWALK, CURBING, UTILITIES, FENCES, WALLS, PLANTINGS, OTHER INFRASTRUCTURE AND APPURTENANCES DISTURBED BY CONSTRUCTION ACTIVITIES TO THEIR ORIGINAL EXISTING CONDITION. AREAS AND UTILITIES OUTSIDE THE CONSTRUCTION DISTURBED BY THE CONTRACTOR SHALL BE RESTORED AT NO ADDITIONAL COST TO THE OWNER.
- WORK HOUR RESTRICTIONS SHALL BE IN ACCORDANCE WITH THE CITY OF BOSTON PUBLIC WORKS DEPARTMENT.
- ALL CATCH BASINS WITHIN AND TRIBUTARY TO THE LIMITS OF WORK SHALL BE PROTECTED FROM SEDIMENTS WITH INLET PROTECTION.
- CONTRACTOR IS RESPONSIBLE FOR THE ACQUISITION OF ALL PERMITS AS DEEMED NECESSARY BY THE CITY OF BOSTON AT NO ADDITIONAL COST TO THE AUTHORITY.
- STAGING AREAS DESIRED BY THE CONTRACTOR SHALL BE THE CONTRACTOR'S RESPONSIBILITY. THE CONTRACTOR SHALL COORDINATE ONSITE STAGING WITH THE AUTHORITY IF DESIRED AND IT SHALL BE PROVIDED AT NO ADDITIONAL COST TO THE AUTHORITY.
- ADDITIONAL BURIED UTILITIES/STRUCTURES MAY BE ENCOUNTERED. THE STATUS OF UTILITIES, WHETHER ACTIVE, ABANDONED, OR REMOVED, IS AN UNKNOWN CONDITION.
- THE ACCURACY OF MEASURED UTILITY INVERTS AND PIPE SIZES IS SUBJECT TO FIELD CONDITIONS, THE ABILITY TO MAKE VISUAL OBSERVATIONS, DIRECT ACCESS TO THE VARIOUS ELEMENTS AND OTHER MATTERS.
- RIGHT-OF-WAY LINE AND ADJUTER PROPERTY LINE INFORMATION SHOWN HEREON ARE APPROXIMATE AND ARE NOT WARRANTED TO BE EXACT.
- CONTRACTOR SHALL VERIFY FIELD CONDITIONS BEFORE COMMENCEMENT OF ANY CONSTRUCTION ACTIVITIES. CONTRACTOR SHALL VERIFY EXISTING ELEVATIONS AND DIMENSIONS WHERE NEW WORK WILL MATCH EXISTING. DISCREPANCIES SHALL BE BROUGHT TO THE ATTENTION OF THE AUTHORITY FOR RESOLUTION PRIOR TO THE COMMENCEMENT OF WORK.
- THE CONTRACTOR SHALL BE RESPONSIBLE FOR CONTACTING AND NOTIFYING THE PROPER UTILITY COMPANY AND UTILITY LOCATING SERVICES PRIOR TO CONSTRUCTION.
- CONTRACTOR SHALL TAKE CARE TO AVOID DAMAGE TO EXISTING PAVEMENT, TREES, VEGETATION, STRUCTURES, AND UTILITIES THAT ARE NOT INDICATED TO BE DEMOLISHED, REMOVED, OR RELOCATED. ANY DAMAGE TO EXISTING PAVEMENT, TREES, VEGETATION, STRUCTURES, AND UTILITIES NOT INDICATED TO BE DEMOLISHED, REMOVED OR RELOCATED SHALL BE REPAIRED AT NO ADDITIONAL COST TO THE AUTHORITY.
- WHERE PROPOSED WORK IS IN THE VICINITY OF UTILITY POLES, SUCH THAT SUPPORT OF THE POLE(S) WILL BE REQUIRED, THE CONTRACTOR SHALL BE RESPONSIBLE FOR NOTIFYING THE UTILITY, PUBLIC OR PRIVATE, OF THE WORK. IT WILL BE THE RESPONSIBILITY OF THE CONTRACTOR TO COORDINATE WITH THE UTILITY FOR SUPPORT OF THE POLE.
- WHERE OVERHEAD POWER LINES ARE PRESENT, CONTRACTOR MUST CONTACT THE UTILITY PRIOR TO CONSTRUCTION ACTIVITIES TO DETERMINE THE MINIMUM REQUIRED EQUIPMENT CLEARANCE (MEC) DISTANCE.
- THE CONTRACTOR SHALL REMOVE AND LEGALLY DISPOSE OF ALL DEBRIS GENERATED DURING THE PROJECT OFF SITE AT A PROPERLY PERMITTED DISPOSAL FACILITY.
- CONTRACTOR SHALL MAKE EVERY EFFORT TO SAVE AND MAINTAIN ALL PROPERTY IRONS, MONUMENTS, OTHER PERMANENT POINTS AND LINES OF REFERENCE AND CONSTRUCTION STAKES. A MASSACHUSETTS REGISTERED LAND SURVEYOR SHALL REPLACE PROPERTY IRONS, MONUMENTS, AND OTHER PERMANENT POINTS OF REFERENCE DESTROYED BY THE CONTRACTOR, AT NO ADDITIONAL COST TO THE AUTHORITY.

REFERENCE MONUMENT NAME/NUMBER	COORDINATES	ELEVATION
NAIL IN UTILITY POLE #125	N2955131 E799952	16.56 BCB
CHISEL-SO FOUND ON CORNER OF CONC. PAD	N2954979 E800197	18.67 BCB



Hazen
HAZEN AND SAWYER
24 FEDERAL STREET, 5TH FLOOR
BOSTON, MASSACHUSETTS 02110

REG. PROF. ENGR. _____ DATE _____
REG. PROF. ENGR. _____ DATE _____

SCALE: AS SHOWN									
DESIGNED BY: KTR									
DRAWN BY: KTR									
CHECKED BY: AA									
APPROVED BY: AA									
NUMBER	DATE	MADE BY	CHECKED BY	REVISIONS					
				DESCRIPTION					

MASSACHUSETTS WATER RESOURCES AUTHORITY
DEER ISLAND TREATMENT PLANT

**PARKING LOT MODIFICATIONS
CIVIL LEGEND, ABBREVIATIONS
AND NOTES**

CIVIL
MAY 2020

PROJECT NO.	
CONTRACT NO.	7645
CAD FILE NO.	7645_TO4_C-001
SHEET NO.	7645_TO4_C-001

- NOTES:**
1. INSTALL PERIMETER EROSION CONTROLS AND INLET PROTECTION PRIOR TO COMMENCING DEMOLITION WORK.
 2. TRUCKS OR HEAVY EQUIPMENT SHALL NOT BE ALLOWED WITHIN TREE PROTECTION LIMITS. ONLY HAND LABOR WILL BE ALLOWED. CONSTRUCTION MATERIALS, SOIL DEPOSITS, OR SOLVENTS SHALL NOT BE ALLOWED WITHIN TREE PROTECTION LIMITS.
 3. ALL TREE PROTECTION MEASURES ARE TO BE IN PLACE PRIOR TO CONSTRUCTION ACTIVITIES NEAR TREES. TREE PROTECTION IS TO REMAIN IN PLACE AND MAINTAINED UNTIL CONSTRUCTION IS COMPLETE AND ALL HEAVY EQUIPMENT IS REMOVED FROM THE AREA. DETAIL FOR TREE PROTECTION CAN BE FOUND ON DRAWING NO. C-007.
 4. LOCATION OF EXISTING TREES/SHRUBS TO BE REMOVED IS APPROXIMATE. FINAL LOCATION TO BE DETERMINED IN THE FIELD BY THE AUTHORITY.
 5. FOR ELECTRICAL DEMOLITION WORK, SEE TO DRAWING NO. E-002.
 6. LIMITS OF SAWCUTTING SHALL BE AT THE LIMITS OF DEMOLITION AS INDICATED ON THIS SHEET AND DRAWING NO. E-002, AND AT THE LIMITS OF NEW WORK AS INDICATED ON DRAWING NO. C-003 THROUGH E-003.

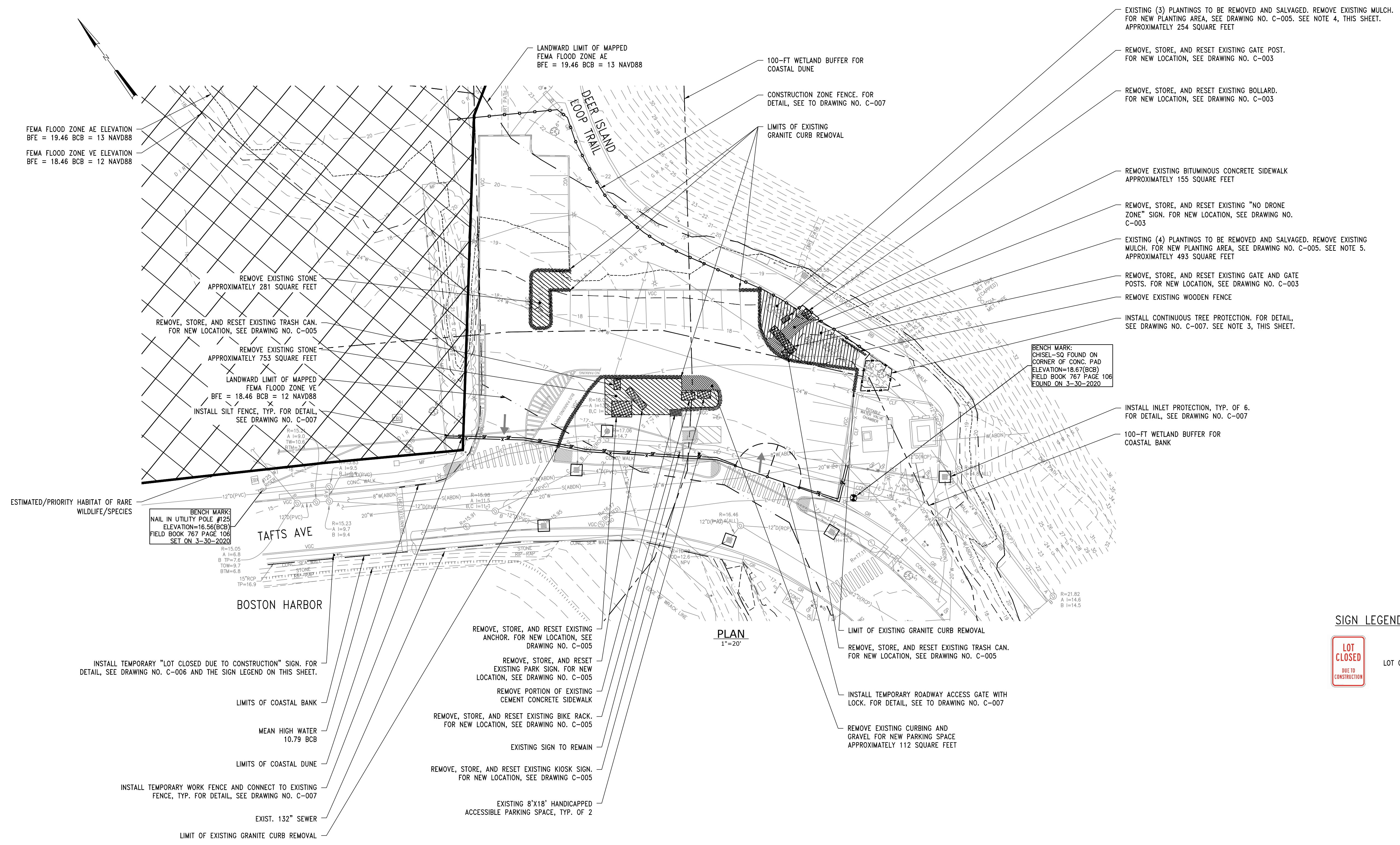

- EXISTING (3) PLANTINGS TO BE REMOVED AND SALVAGED. REMOVE EXISTING MULCH. FOR NEW PLANTING AREA, SEE DRAWING NO. C-005. SEE NOTE 4, THIS SHEET. APPROXIMATELY 254 SQUARE FEET
- REMOVE, STORE, AND RESET EXISTING GATE POST. FOR NEW LOCATION, SEE DRAWING NO. C-003
- REMOVE, STORE, AND RESET EXISTING BOLLARD. FOR NEW LOCATION, SEE DRAWING NO. C-003
- REMOVE EXISTING BITUMINOUS CONCRETE SIDEWALK APPROXIMATELY 155 SQUARE FEET
- REMOVE, STORE, AND RESET EXISTING "NO DRONE ZONE" SIGN. FOR NEW LOCATION, SEE DRAWING NO. C-003
- EXISTING (4) PLANTINGS TO BE REMOVED AND SALVAGED. REMOVE EXISTING MULCH. FOR NEW PLANTING AREA, SEE DRAWING NO. C-005. SEE NOTE 5. APPROXIMATELY 493 SQUARE FEET
- REMOVE, STORE, AND RESET EXISTING GATE AND GATE POSTS. FOR NEW LOCATION, SEE DRAWING NO. C-003
- REMOVE EXISTING WOODEN FENCE
- INSTALL CONTINUOUS TREE PROTECTION. FOR DETAIL, SEE DRAWING NO. C-007. SEE NOTE 3, THIS SHEET.
- INSTALL INLET PROTECTION, TYP. OF 6. FOR DETAIL, SEE DRAWING NO. C-007
- 100-FT WETLAND BUFFER FOR COASTAL BANK

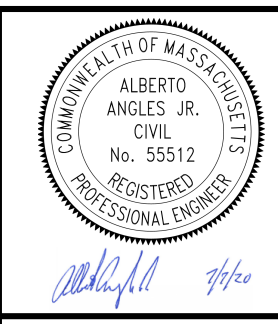
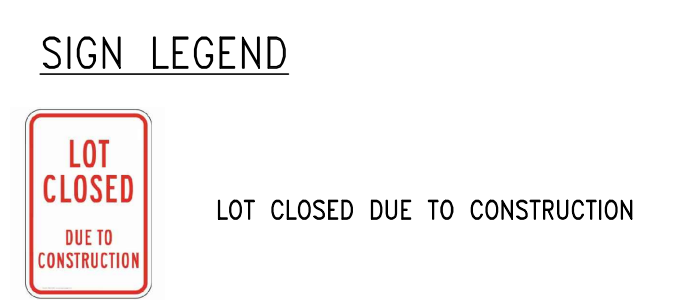

Hazen
HAZEN AND SAWYER
24 FEDERAL STREET, 5TH FLOOR
BOSTON, MASSACHUSETTS 02110

REG. PROF. ENGR. _____ DATE _____
REG. PROF. ENGR. _____ DATE _____

SCALE: AS SHOWN
UNLESS OTHERWISE NOTED OR CHANGED BY REVISION

DESIGNED BY:	KTR
DRAWN BY:	KTR
CHECKED BY:	AA
APPROVED BY:	AA

NUMBER	DATE	MADE BY	CHECKED BY	DESCRIPTION

MASSACHUSETTS WATER RESOURCES AUTHORITY
DEER ISLAND TREATMENT PLANT

**PARKING LOT MODIFICATIONS
EXISTING CONDITIONS, DEMOLITION AND
EROSION AND SEDIMENT CONTROL PLAN**

PROJECT NO. _____
CONTRACT NO. **7645**
CAD FILE NO. **7645_T04_C-002**
SHEET NO. **7645_T04_C-002**



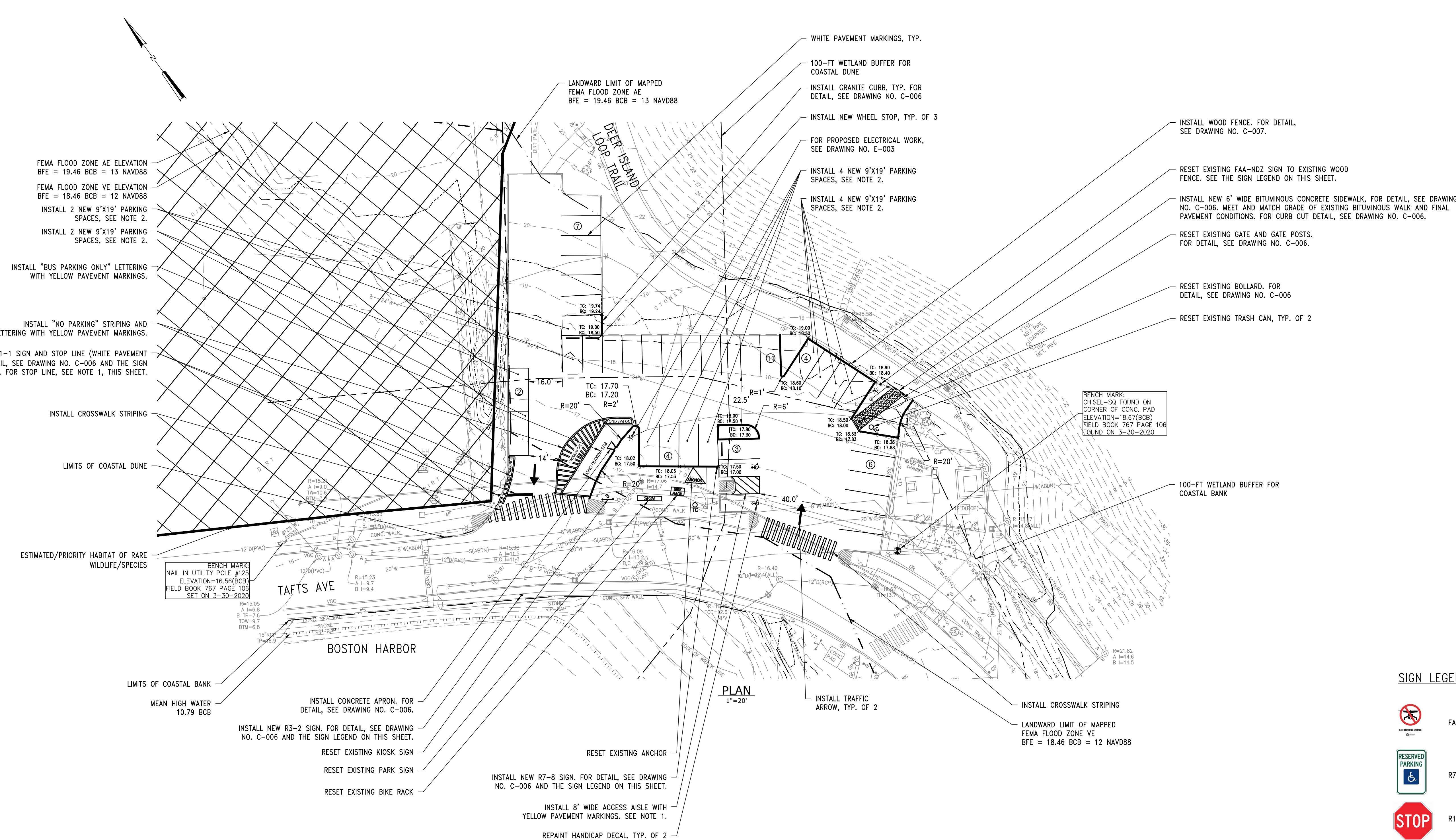

CIVIL MAY 2020

NOTES:

- ONE HANDICAPPED SPACE IS DESIGNATED FOR VAN PARKING AND REQUIRES AN EIGHT FOOT WIDE ACCESS AISLE AS INDICATED. THIS PARKING SPACE SHALL BE IDENTIFIED AS "VAN ACCESSIBLE" WITH SIGNAGE.
- THE CONTRACTOR SHALL FURNISH AND INSTALL PAVEMENT MARKINGS AND SIGNAGE AS INDICATED, COMPLIANT WITH MASS DOT STANDARDS. PAVEMENT MARKINGS SHALL CONFORM TO MASS DOT STANDARD SECTION M7.01.03 FOR WHITE MARKINGS AND M7.01.04 FOR YELLOW MARKINGS AND US DOT CHAPTER 38.18. CONVENTIONAL PARKING SPACES ARE NINE FEET IN WIDTH. HANDICAPPED PARKING SPACES ARE EIGHT FEET IN WIDTH AND SHARE A COMMON ACCESS AISLE.
- FOR NEW PARKING SPACES BEING INSTALLED OVER EXISTING PAVEMENT SURFACES, CONTRACTOR SHALL INSTALL NEW PERMANENT PAVEMENT. FOR DETAIL SEE TO DRAWING NO. C-006.



SIGN LEGEND

-  FAA-NDZ
-  R7-B
-  R1-1
-  R3-2

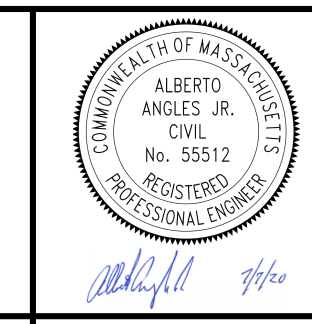
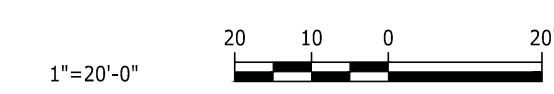

Hazen
HAZEN AND SAWYER
24 FEDERAL STREET, 5TH FLOOR
BOSTON, MASSACHUSETTS 02110

REG. PROF. ENGR. _____ DATE _____
REG. PROF. ENGR. _____ DATE _____

SCALE: AS SHOWN
ALL RIGHTS RESERVED OR
OWNED BY REPRODUCTION

DESIGNED BY: KTR	NUMBER	DATE	MADE BY	CHECKED BY	DESCRIPTION
DRAWN BY: KTR					
CHECKED BY: AA					
APPROVED BY: AA					

REVISIONS

MASSACHUSETTS WATER RESOURCES AUTHORITY
DEER ISLAND TREATMENT PLANT

**PARKING LOT MODIFICATIONS
PARKING AREA SITE LAYOUT**

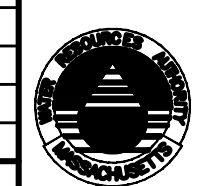

CIVIL
MAY 2020

PROJECT NO.	
CONTRACT NO.	7645
CAD FILE NO.	7645_TO4_C-003
SHEET NO.	7645_TO4_C-003

- NOTES:
- CONTRACTOR SHALL PERFORM GEOTECHNICAL INVESTIGATIONS AT THE LEACHING CATCH BASIN LOCATION CONSISTING OF ONE BORING (15 FT DEPTH) AND A FALLING-HEAD IN-SITU PERMEABILITY TEST (ASTM D5126-90 METHOD) AT 5FT AND 10FT DEPTH INTERVAL. PROVIDE SUBSURFACE INFORMATION RESULTS AND GROUNDWATER TABLE IF ENCOUNTERED TO THE AUTHORITY PRIOR TO THE INSTALLATION OF THE LEACHING CATCH BASIN. UPON REVIEW OF THE RESULTS, IT MAY BE REQUIRED TO MAKE MODIFICATIONS TO THE DEPTH AND LOCATION OF THE LEACHING CATCH BASIN.
 - THE LEACHING CATCH BASIN SHALL HAVE A MINIMUM OF 120 CF STORAGE CAPACITY.

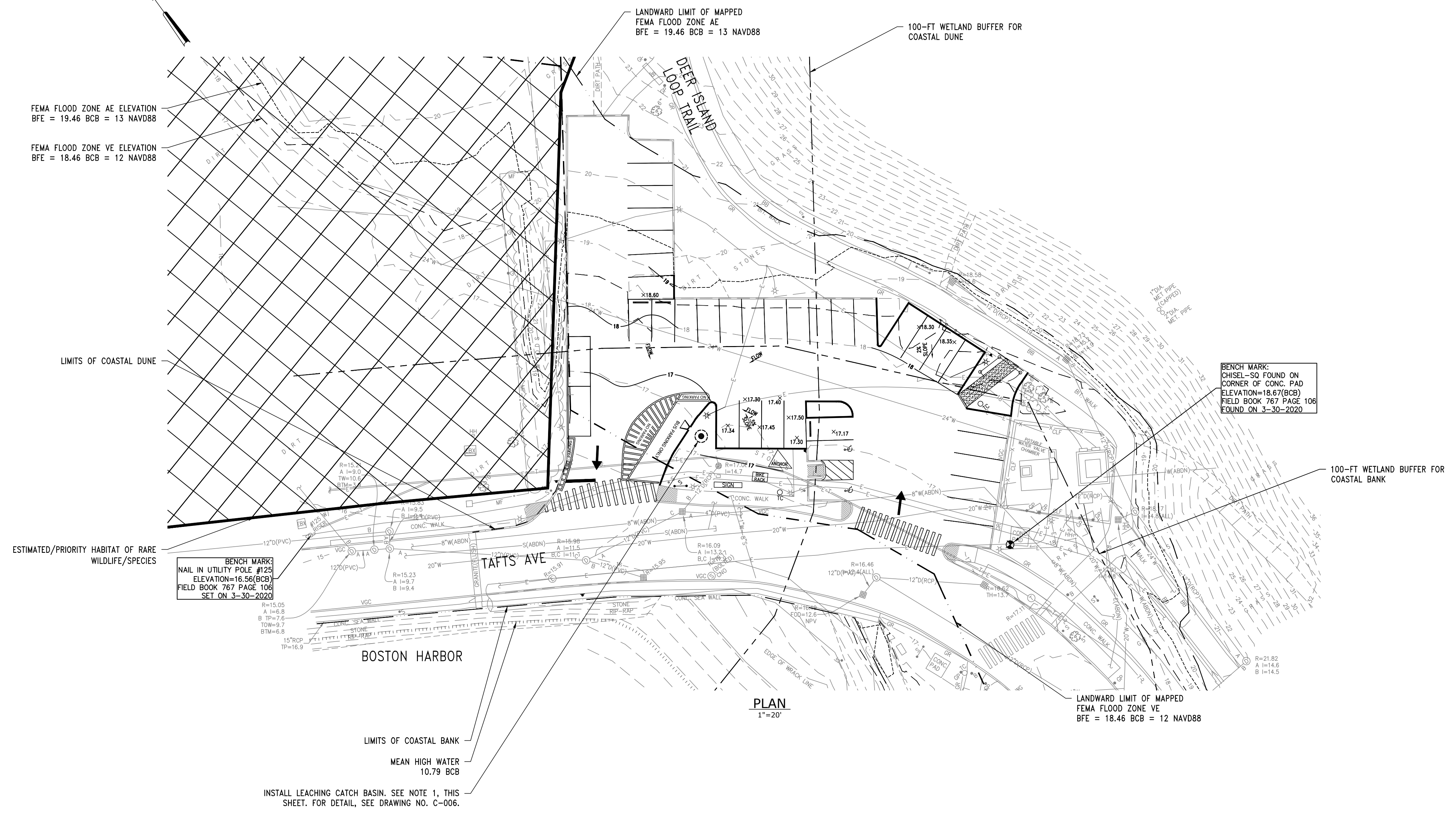

PLAN
1"=20'

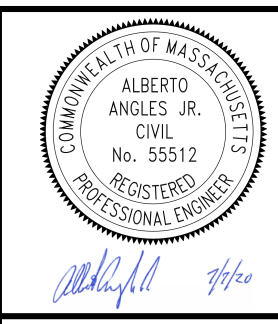
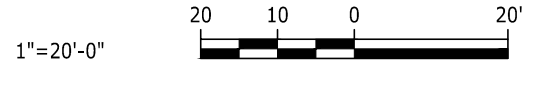

Hazen
HAZEN AND SAWYER
24 FEDERAL STREET, 5TH FLOOR
BOSTON, MASSACHUSETTS 02110

SCALE: AS SHOWN
DESIGNED BY: KTR
DRAWN BY: KTR
CHECKED BY: AA
APPROVED BY: AA

NUMBER	DATE	MADE BY	CHECKED BY	DESCRIPTION

MASSACHUSETTS WATER RESOURCES AUTHORITY
DEER ISLAND TREATMENT PLANT

**PARKING LOT MODIFICATIONS
STORMWATER INFILTRATION SYSTEM
AND GRADING PLAN**

PROJECT NO. _____
CONTRACT NO. 7645
CAD FILE NO. 7645_T04_C-004
SHEET NO. 7645_T04_C-004

CIVIL MAY 2020

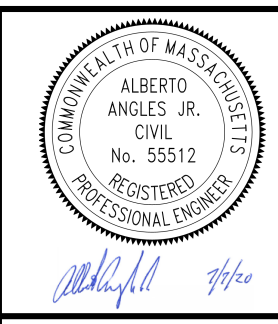
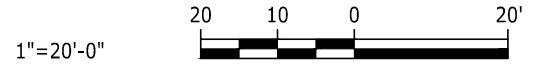
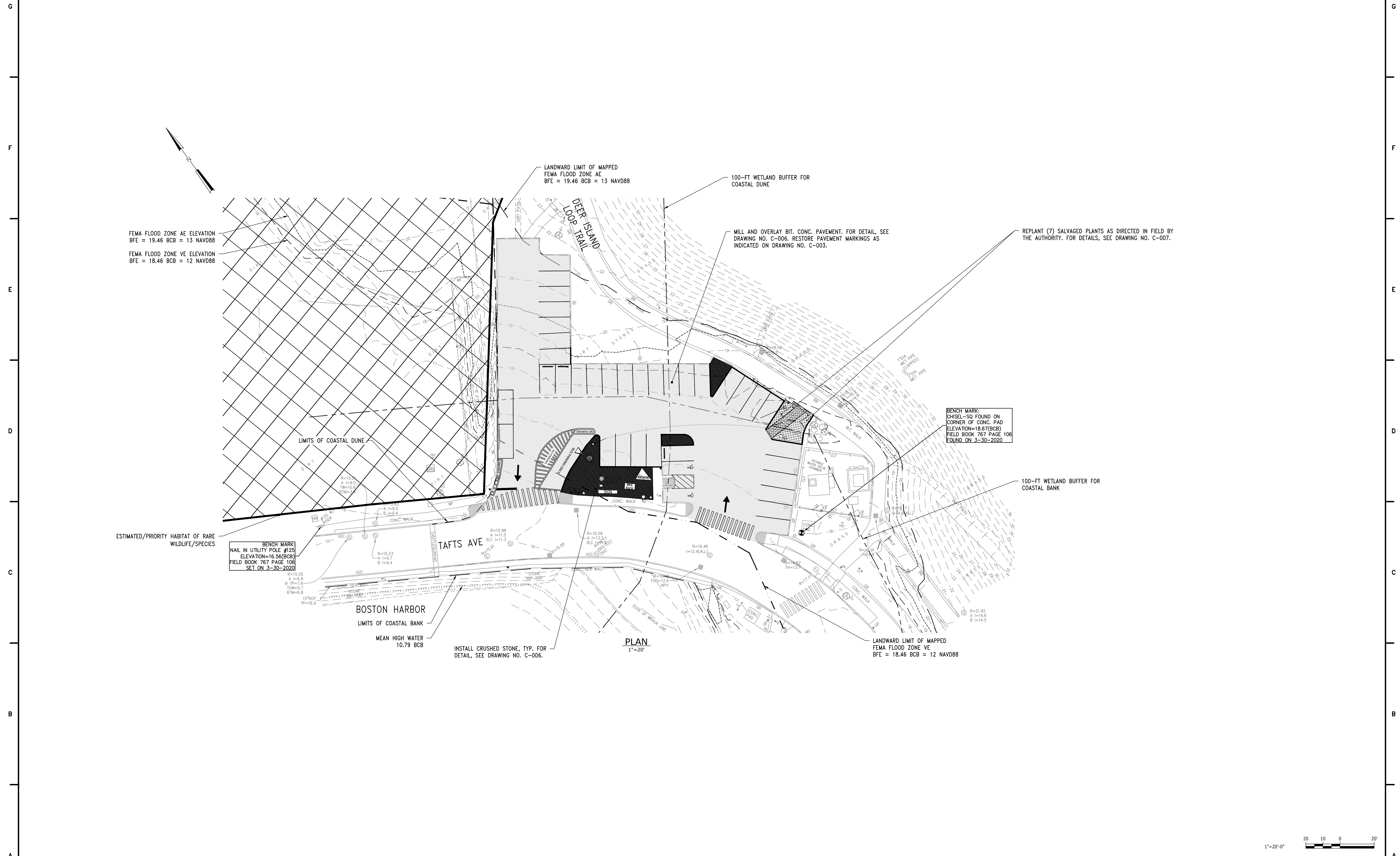

Hazen
HAZEN AND SAWYER
24 FEDERAL STREET, 5TH FLOOR
BOSTON, MASSACHUSETTS 02110

REG. PROF. ENGR. _____ DATE _____
REG. PROF. ENGR. _____ DATE _____

SCALE: AS SHOWN
ALL DIMENSIONS UNLESS OTHERWISE NOTED OR CHANGED BY REVISION

DESIGNED BY:	KTR
DRAWN BY:	KTR
CHECKED BY:	AA
APPROVED BY:	AA

NUMBER	DATE	MADE BY	CHECKED BY	REVISIONS	DESCRIPTION

MASSACHUSETTS WATER RESOURCES AUTHORITY
DEER ISLAND TREATMENT PLANT
PARKING LOT MODIFICATIONS
FINAL SITE PLAN

CIVIL
MAY 2020

PROJECT NO. _____
CONTRACT NO. 7645
CAD FILE NO. 7645_T04_C-005
SHEET NO. 7645_T04_C-005

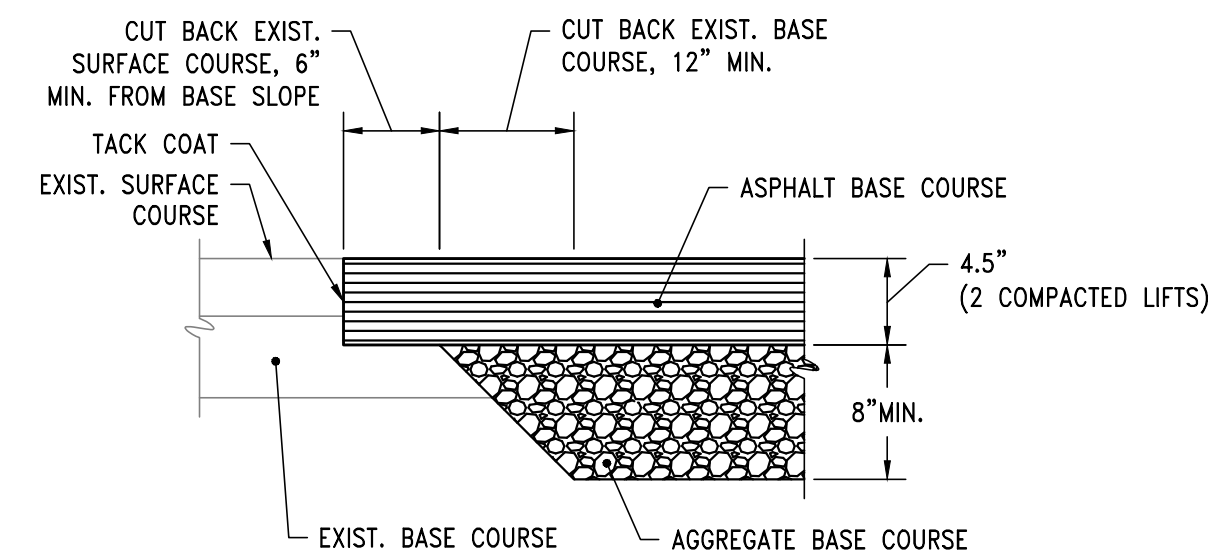

NOTES:
 1. PERMANENT PAVEMENT IS TO BE INSTALLED AT NEW PARKING LOCATIONS.
 2. SEE MILL AND OVERLAY DETAIL THIS SHEET FOR FINAL CONDITIONS.

PERMANENT PAVEMENT
 NTS

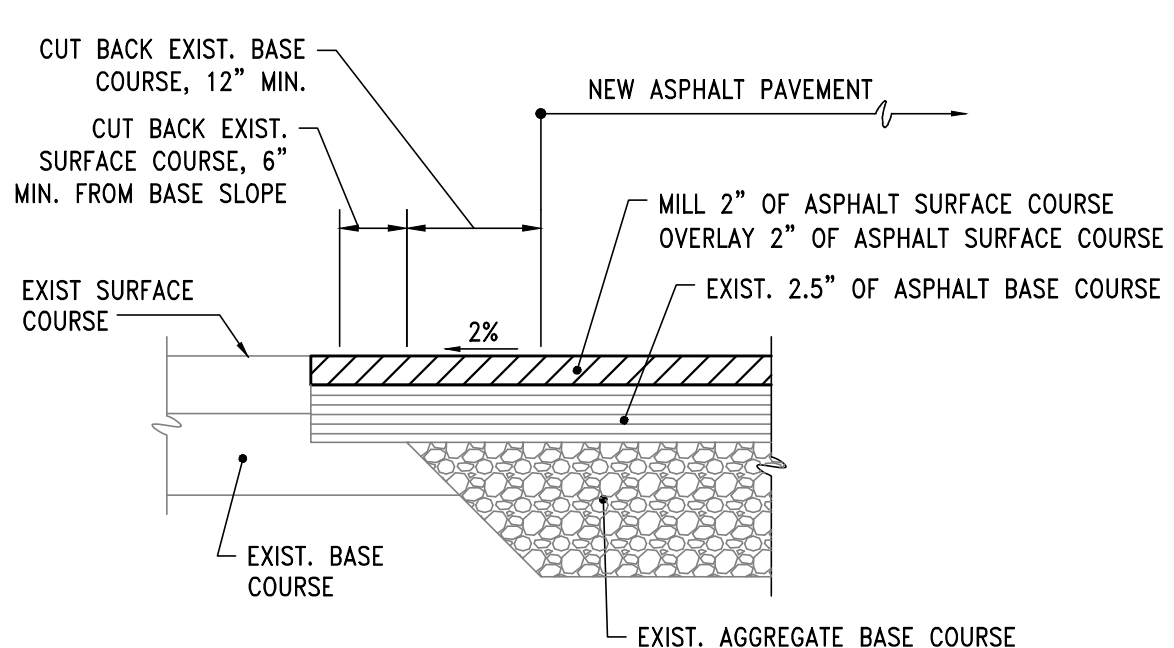

NOTES:
 1. REPAIR HOLES AND CRACKS IN EXISTING SURFACE.
 2. CONSTRUCT ASPHALT BASE COURSE TO INSURE PROPER CROWN WHEN THE FINAL SURFACE LAYER IS APPLIED. SEE SECTION 02525 - PAVING.

MILL AND OVERLAY
 NTS

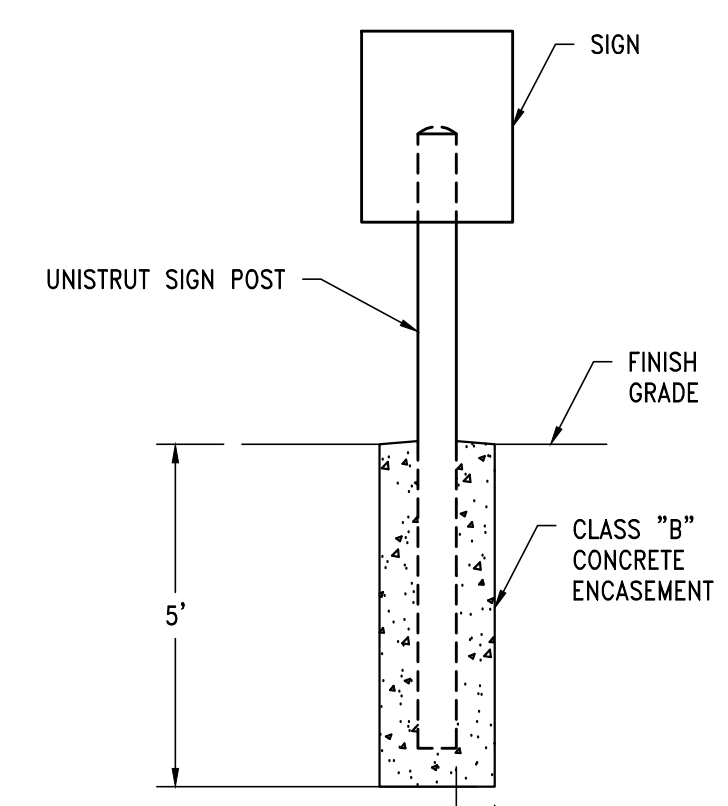

NOTES:
 1. SIGNS SHALL BE INSTALLED IN COMPLIANCE WITH LOCAL, STATE AND FEDERAL REGULATIONS.
 2. NEW SIGNS SHALL CONFORM TO THE 2009 MUTCD FOR SIZE, COLOR, TEXT DIMENSION, ETC.

SIGN INSTALLATION
 NTS

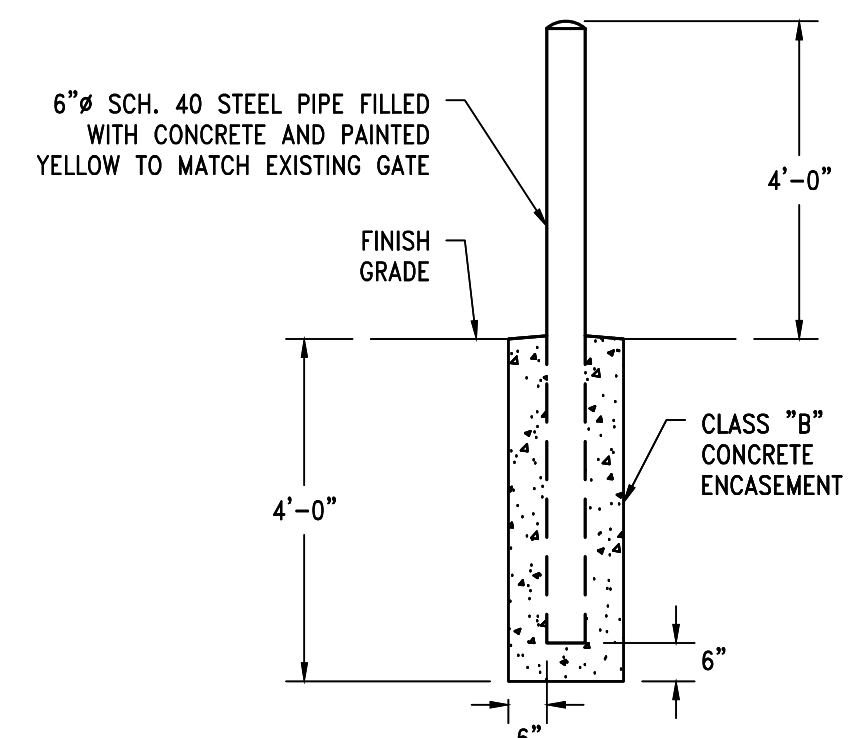

BOLLARD INSTALLATION
 NTS

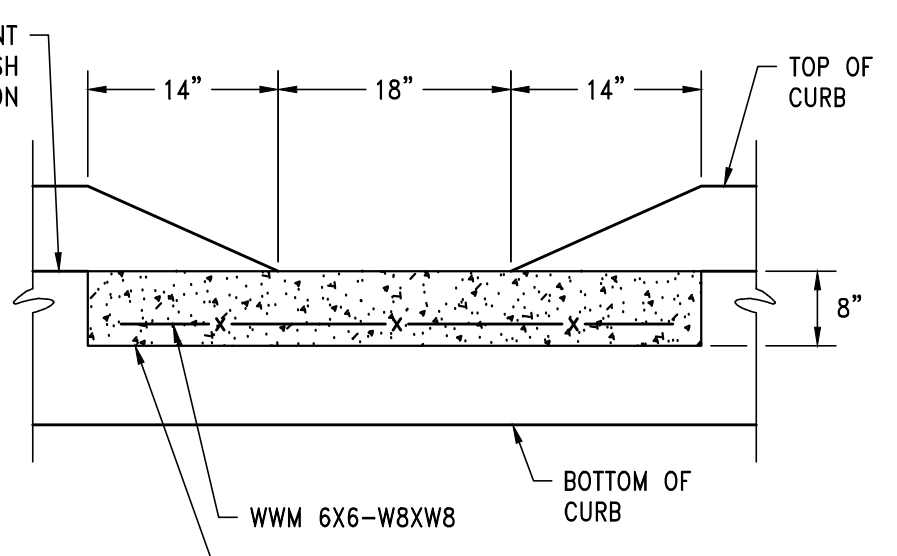
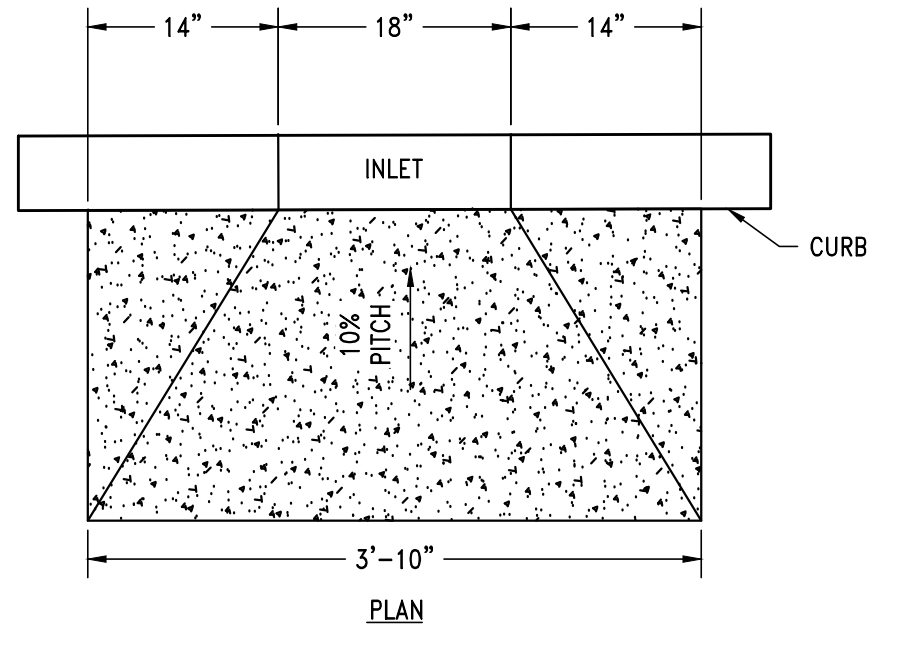

CONCRETE APRON
 NTS

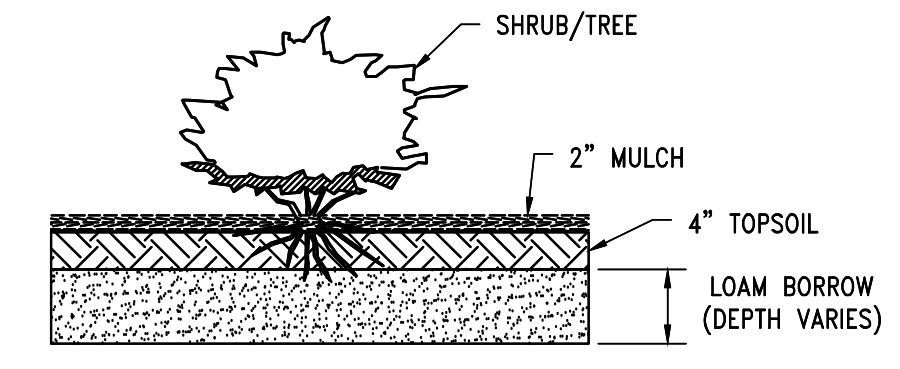

NOTES:
 1. REFER TO SECTION 02200 - EARTHWORK FOR BACKFILL MATERIALS AND DEPTHS.

LANDSCAPE RESTORATION
 NTS

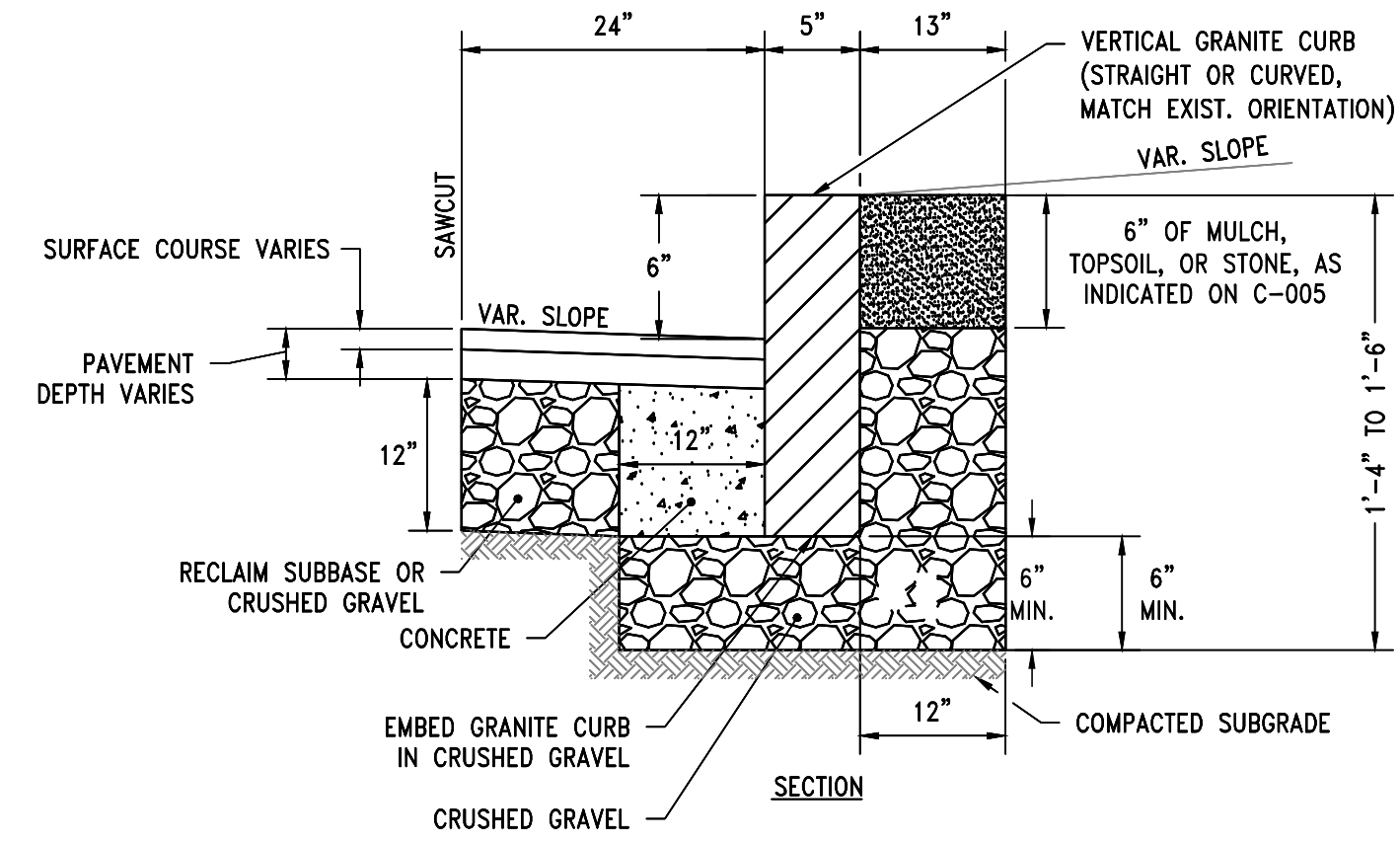

NOTES:
 1. MINIMUM LENGTH OF CURB STONES - 3'
 2. MAXIMUM LENGTH OF CURB STONES - 10'
 3. MAXIMUM LENGTH OF STRAIGHT CURB STONES LAID ON CURVES - SEE CHART. ADJOINING STONES SHALL HAVE THE SAME OR APPROXIMATELY THE SAME LENGTH.
 4. CURB ENDS TO BE TIPPED DOWN.
 5. FOR NEW CURB ADJACENT TO EXISTING CURB, TRANSITION THE NEW CURB REVEAL TO MATCH THE EXISTING CURB REVEAL. NEW CURB REVEAL SHALL NOT EXCEED 6-INCHES.
 6. FOR CURBING AT SIDEWALK AND PAVEMENT TRANSITIONS, REFER TO CURB CUT DETAIL ON THIS SHEET.

VERTICAL GRANITE CURB
 NTS

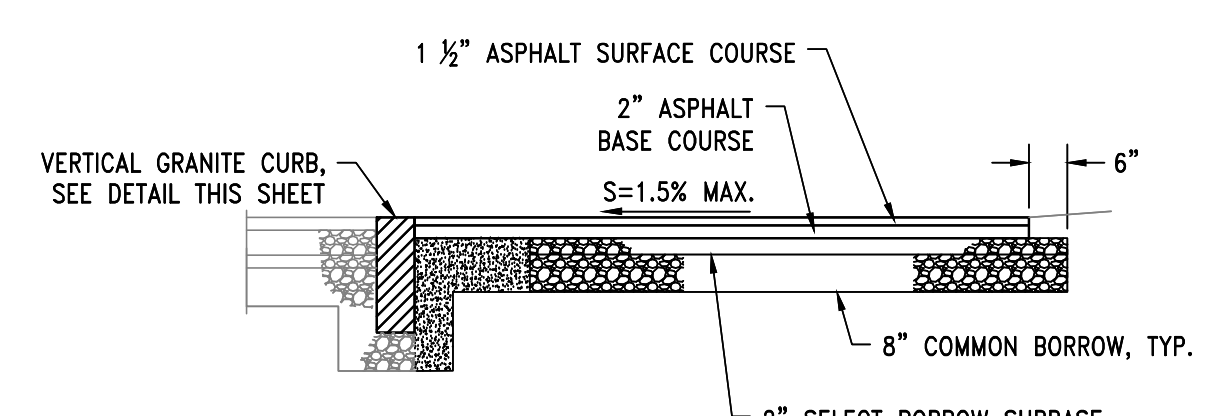

BITUMINOUS CONCRETE SIDEWALK
 NTS

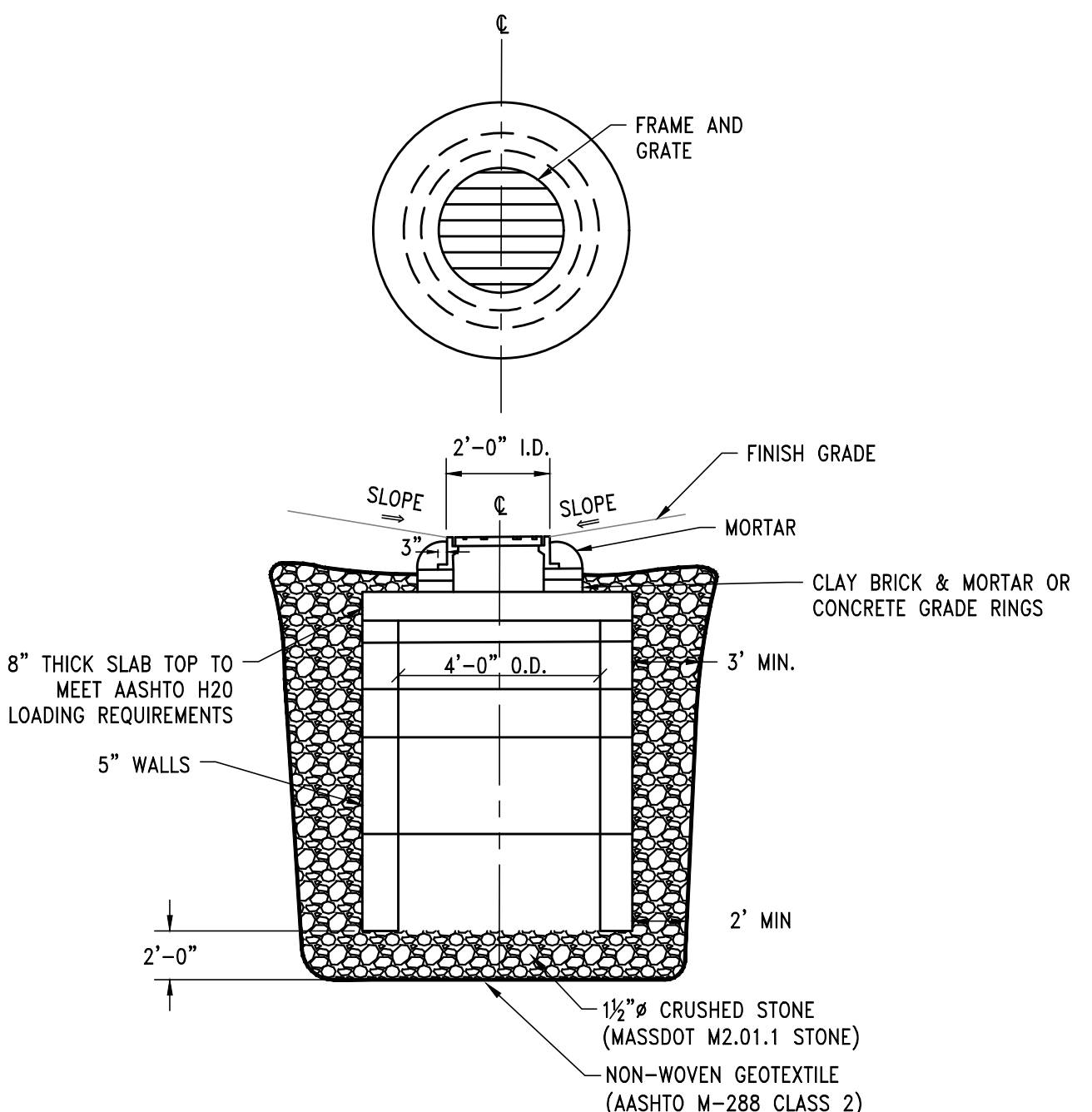

NOTES:
 1. CONCRETE 4000 PSI MIN. @ 28 DAYS; CEMENT TO BE TYPE III PER ASTM C-150.
 2. STRUCTURE TO MEET REQUIREMENTS OF ASTM C-478 AND AASHTO M199.
 3. CIRCUMFERENTIAL REINFORCING TO MEET ASTM A-185.
 4. TOP SLAB TO MEET ASTM A-615 GRADE 60; DEFORMED BARS PLACES PER ASTM C-478.

LEACHING CATCH BASIN
 NTS

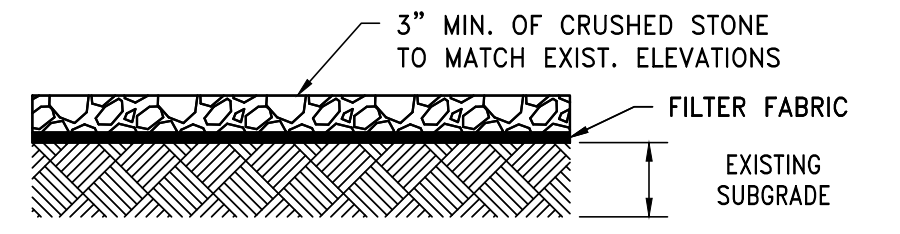

STONE RESTORATION
 NTS

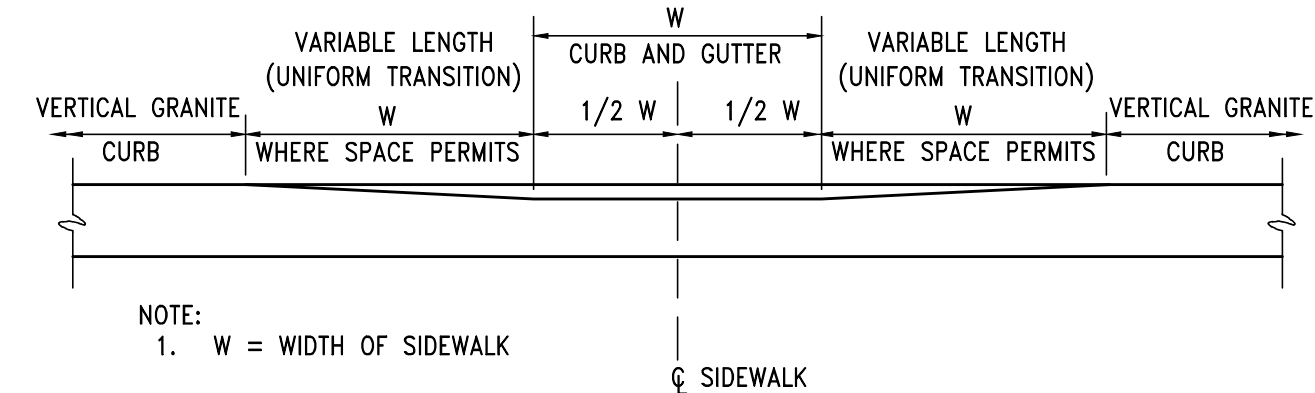

NOTE:
 1. W = WIDTH OF SIDEWALK

CURB CUT
 NTS

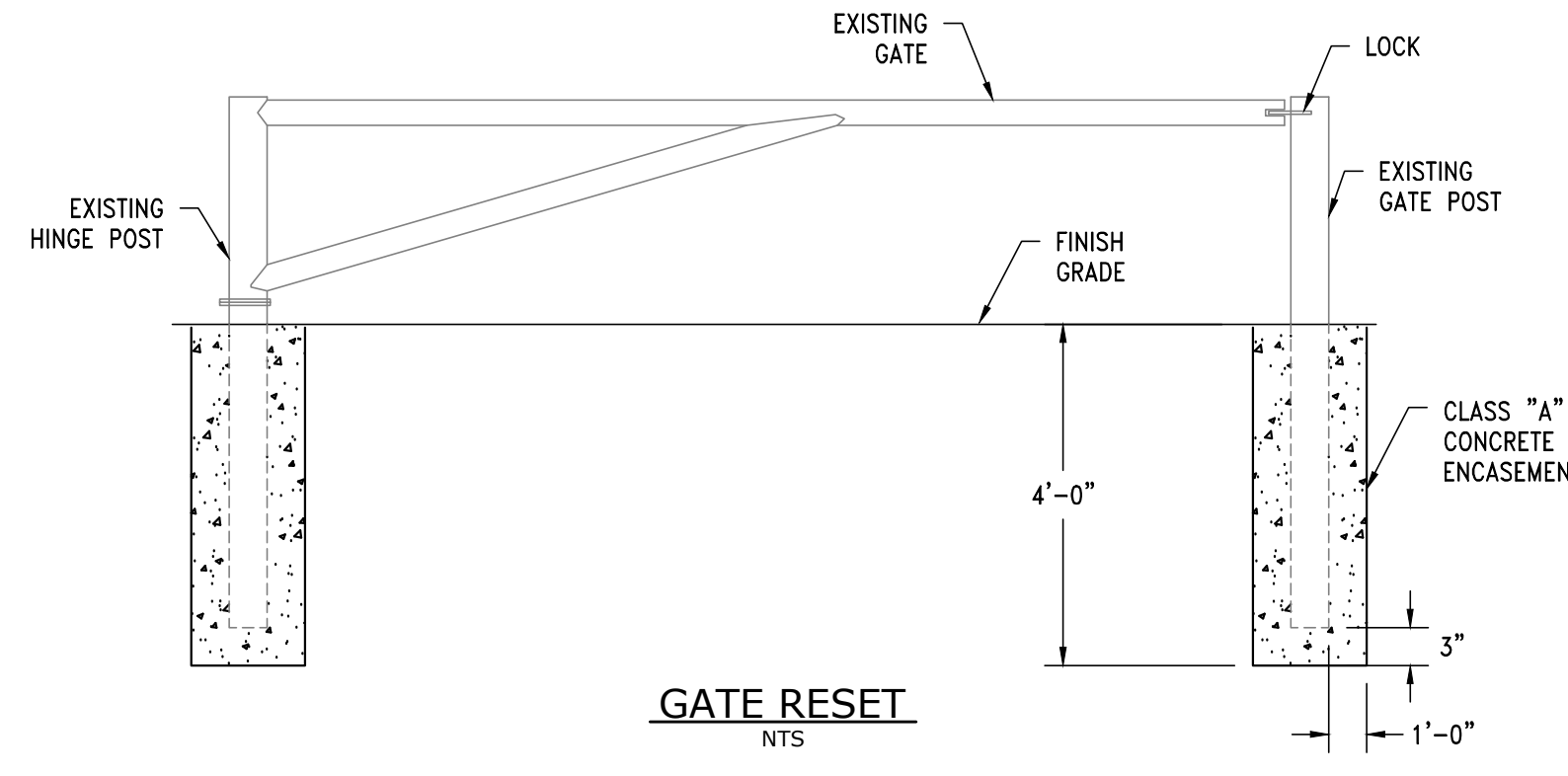

GATE RESET
 NTS

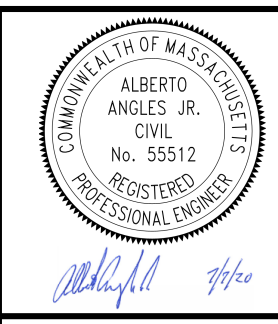

Hazen
 HAZEN AND SAWYER
 24 FEDERAL STREET, 5TH FLOOR
 BOSTON, MASSACHUSETTS 02110

SCALE: AS SHOWN	DESIGNED BY: KTR	CHECKED BY: AA	APPROVED BY: AA
DRAWN BY: KTR	CHECKED BY: AA	APPROVED BY: AA	
DATE	DATE	DATE	DATE
NUMBER	DATE	MADE BY	CHECKED BY
REVISIONS			
DESCRIPTION			

MASSACHUSETTS WATER RESOURCES AUTHORITY
 DEER ISLAND TREATMENT PLANT
PARKING LOT MODIFICATIONS
 STANDARD DETAILS I

PROJECT NO. _____
 CONTRACT NO. 7645
 CAD FILE NO. 7645_T04_C-006
 SHEET NO. 7645_T04_C-006

EROSION AND SEDIMENT CONTROL NOTES:

1. DUE TO THE NATURE OF THE WORK REQUIRED BY THIS CONTRACT, IT IS ANTICIPATED THE LOCATION AND NATURE OF EROSION AND SEDIMENT CONTROL MEASURES WILL BE ADJUSTED AS CONSTRUCTION PROGRESSES AS REQUIRED TO REFLECT THE CURRENT PHASE OF WORK. THE CONSTRUCTION SCHEDULE ADOPTED BY THE CONTRACTOR WILL IMPACT THE PLACEMENT AND NEED FOR SPECIFIC DEVICES REQUIRED FOR THE CONTROL OF EROSION. THE LOCATION AND EXTENT OF EROSION AND SEDIMENT CONTROL MEASURES SHALL BE REVISED AT EACH PHASE OF CONSTRUCTION FOR THE QUANTITY OR DIRECTION OF SURFACE RUNOFF FROM THE CONSTRUCTION AREAS AS A RESULT OF THAT CONSTRUCTION PHASE.
2. EROSION AND SEDIMENT CONTROLS SHALL BE INSTALLED AS INDICATED ON THE DRAWINGS.
3. CONTRACTOR SHALL OBTAIN PRIOR APPROVAL, IN WRITING, FROM THE AUTHORITY FOR DEVIATIONS FROM THE APPROVED EROSION AND SEDIMENT CONTROL PLAN.
4. NO LAND DISTURBANCE, DEMOLITION OR CONSTRUCTION ACTIVITIES SHALL BEGIN UNTIL ALL PERIMETER EROSION AND SEDIMENT CONTROL MEASURES, INCLUDING, BUT NOT LIMITED TO, SILT FENCING, INLET PROTECTION, TEMPORARY DIVERSIONS, AND TREE PROTECTION HAVE BEEN INSTALLED AS INDICATED ON THE CONTRACT DRAWINGS. IF CLEARING IS REQUIRED FOR INSTALLATION OF A PARTICULAR MEASURE, ALL MEASURES NOT REQUIRING CLEARING SHALL BE INSTALLED FIRST. CLEARING OF THE NECESSARY LAND FOR INSTALLATION OF THE PARTICULAR MEASURE MAY THEN PROCEED.
5. CLEARING SHALL BE LIMITED AS MUCH AS POSSIBLE TO AREAS REQUIRED FOR CURRENT CONSTRUCTION ACTIVITIES. MASS CLEARING AND GRADING SHALL BE AVOIDED.
6. ALL EROSION CONTROL MEASURES SHALL BE INSPECTED WITHIN 24 HOURS FOLLOWING EVERY RAINFALL, BUT IN NO CASE LESS THAN ONCE EVERY SEVEN CALENDAR DAYS, TO ENSURE THE EROSION CONTROL MEASURES ARE IN PROPER WORKING ORDER, AND THAT ANY REQUIRED REPAIRS ARE MADE IN A TIMELY FASHION. THE AUTHORITY MAY INSPECT EROSION CONTROL MEASURES AT ANY TIME AND REQUIRE REPAIRS OR MODIFICATIONS AS REQUIRED TO MAINTAIN THE EROSION CONTROL SYSTEM IN GOOD WORKING ORDER.
7. EROSION AND SEDIMENT CONTROL MEASURES SHALL BE REPAIRED OR REPLACED IMMEDIATELY AS REQUIRED TO MAINTAIN PERFORMANCE OF MEASURE. MEASURES SHALL BE CLEANED WHEN SEDIMENT VOLUME REACHES 1/2 OF TOTAL VOLUME OF MEASURE. REMOVED SEDIMENT SHALL BE DISPOSED OF IN SUCH A MANNER AND LOCATION AS TO INSURE FURTHER SEDIMENT TRANSPORT DOES NOT OCCUR.
8. CONTRACTOR SHALL INITIATE STABILIZATION MEASURES AS SOON AS PRACTICABLE ON STOCKPILES AND IN PORTIONS OF THE SITE WHERE CONSTRUCTION ACTIVITIES HAVE TEMPORARILY OR PERMANENTLY CEASED, BUT IN NO CASE MORE THAN 7 DAYS AFTER THE CONSTRUCTION ACTIVITY IN THAT PORTION OF THE SITE HAS TEMPORARILY OR PERMANENTLY CEASED. THIS REQUIREMENT DOES NOT APPLY IN THE FOLLOWING INSTANCES:
9. SOIL STOCKPILE AND LAYDOWN AREAS SHALL HAVE PERIMETER SEDIMENT CONTROL MEASURES AND TEMPORARY OR PERMANENT STABILIZATION MEASURES INSTALLED AS SOON AS POSSIBLE AND AT COMPLETION OF STOCKPILING AND LAYDOWN ACTIVITIES. STOCKPILE SIDE SLOPES SHALL NOT EXCEED 3H:1V UNLESS APPROVED BY THE AUTHORITY. TOP OF STOCKPILE SHALL BE GRADED WITH A MINIMUM 5% SLOPE TO INSURE PROPER DRAINAGE.
10. ALL DISTURBED AREAS, EXCEPT FOR CONCRETE AND PAVED AREAS, SHALL BE MULCHED AND/OR A STONE LAYER INSTALLED IN ACCORDANCE WITH THE SPECIFICATIONS AND THE SEEDING SCHEDULE, AND RE-SEEDED AS NECESSARY, TO ESTABLISH AND MAINTAIN A VIGOROUS, DENSE VEGETATIVE COVER.
11. ALL POINTS OF CONSTRUCTION INGRESS AND EGRESS SHALL BE PROTECTED TO PREVENT THE DEPOSITION OF MATERIALS ONTO TRAVERSED OFFSITE ROADWAYS. IF MATERIAL IS TRACKED ONTO OFFSITE ROADWAYS, IT SHALL BE REMOVED IMMEDIATELY. DO NOT UTILIZE A WATER HOSE TO CLEAN ROADS UNLESS THE RUNOFF IS DIRECTED TO A PROPERLY DESIGNED AND FUNCTIONING SEDIMENT CONTROL DEVICE. PROPER PRECAUTIONS SHALL BE TAKEN TO ENSURE THAT MATERIALS DEPOSITED ONTO OFFSITE ROADWAYS ARE REMOVED SO THAT THEY DO NOT ENTER YARD INLETS, CATCH BASINS, SEWERS, WETLANDS, SURFACE WATER BODIES, OR ROADSIDE SWALES.
12. EARTHEN-MATERIAL STOCKPILES SHALL BE LOCATED A MINIMUM OF 50' FROM STORM DRAINS AND STREAMS UNLESS NO REASONABLE ALTERNATIVES ARE AVAILABLE.
13. DEDICATED AREAS FOR DEMOLITION, CONSTRUCTION, AND OTHER WASTES SHALL BE LOCATED A MINIMUM OF 50' FROM STORM DRAINS AND STREAMS UNLESS NO REASONABLE ALTERNATIVES ARE AVAILABLE.
14. ALL WORK PERFORMED SHALL BE IN ACCORDANCE WITH THE 'MASSACHUSETTS EROSION AND SEDIMENT CONTROL GUIDELINES FOR URBAN AND SUBURBAN AREAS MANUAL', LATEST EDITION, AND IN ACCORDANCE WITH THE CONTRACT DOCUMENTS.
15. STAGING AREA, STOCKPILES, AND OTHER STORAGE LOCATIONS SHALL BE PROTECTED FROM EROSION. ANY EXCAVATED SPOILS REMOVED FROM THE SITE SHALL BE TRANSPORTED IN A SEALED/WATERTIGHT CONTAINER AND DISPOSED OF AT AN APPROVED FACILITY.
16. PAVED ROADWAYS SHALL BE KEPT CLEAN AT ALL TIMES. DO NOT UTILIZE A FIRE OR GARDEN HOSE TO CLEAN ROADS UNLESS THE RUNOFF IS DIRECTED TO A PROPERLY DESIGNED AND FUNCTIONING SEDIMENT CONTROL DEVICE. WATER PUMPED OUT OF THE EXCAVATED AREAS CONTAINS SEDIMENTS THAT SHALL BE REMOVED PRIOR TO DISCHARGING TO RECEIVING BODIES OF WATER USING REMOVABLE PUMPING STATIONS, SUMP PITS, PORTABLE SEDIMENTATION TANKS AND/OR SILT CONTROL BAGS.
17. THE CONTRACTOR SHALL BE RESPONSIBLE FOR THE DESIGN, INSTALLATION, PERMITTING, AND OPERATION OF A DEWATERING SYSTEM AS REQUIRED FOR THE COMPLETION OF THE WORK. PROCEDURES FOR DEWATERING INCLUDING ASSOCIATED EROSION AND SEDIMENT CONTROL PROPOSED BY THE CONTRACTOR SHALL BE SUBMITTED TO THE AUTHORITY FOR REVIEW PRIOR TO ANY EARTHWORK OPERATIONS. ALL WATER REMOVED BY DEWATERING OPERATIONS SHALL BE DISPOSED OF IN ACCORDANCE WITH MADEP PROCEDURES AND STANDARDS FOR URBAN SOIL EROSION AND SEDIMENT CONTROL.
18. ALL EROSION AND SEDIMENT CONTROL MEASURES SHALL REMAIN IN PLACE UNTIL CONSTRUCTION IS COMPLETE, PERMANENT VEGETATION IS ESTABLISHED ON ALL DISTURBED AREAS, AND LOCAL AUTHORITIES HAVE GIVEN PERMISSION FOR REMOVAL.
19. ALL STORM DRAINAGE INLETS SHALL BE PROTECTED BY ONE OF THE PRACTICES ACCEPTED IN THE STANDARDS, AND PROTECTION SHALL REMAIN UNTIL PERMANENT STABILIZATION HAS BEEN ESTABLISHED. STORM DRAINAGE OUTLET POINTS SHALL BE PROTECTED AS REQUIRED BEFORE THEY BECOME FUNCTIONAL.

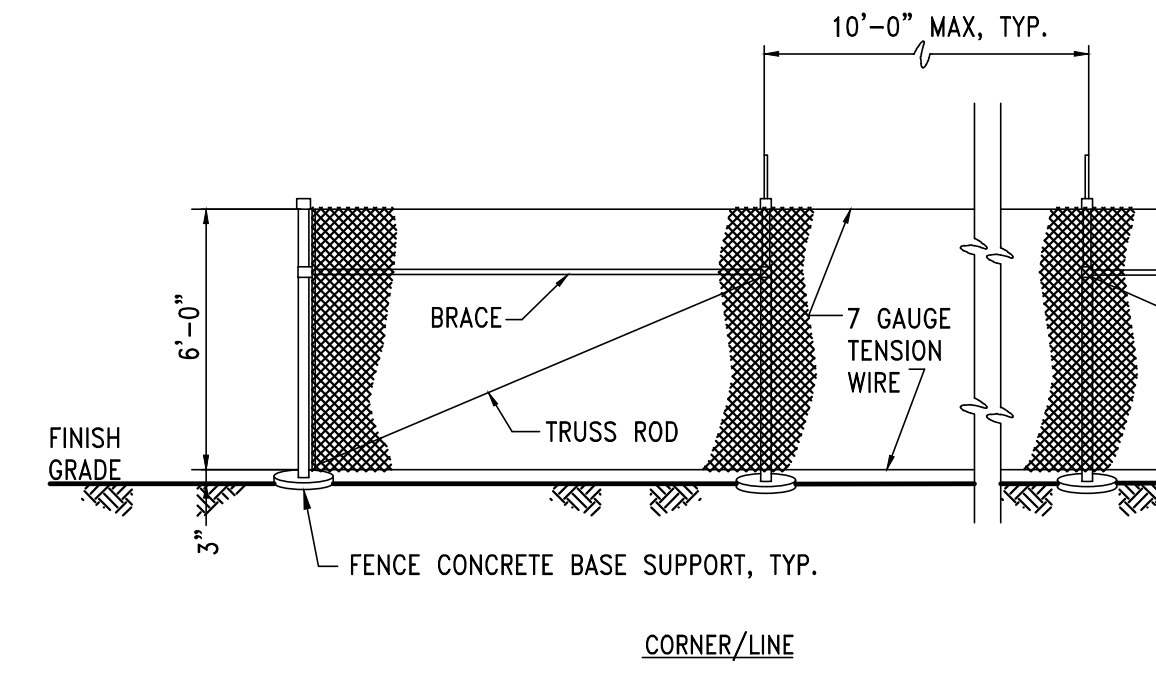

NOTE:
1. CONTRACTOR SHALL BE RESPONSIBLE FOR ENSURING TEMPORARY FENCE BASE SUPPORTS ARE SIZED APPROPRIATELY TO RESIST WIND LOADING.

TEMPORARY CHAIN LINK FENCE

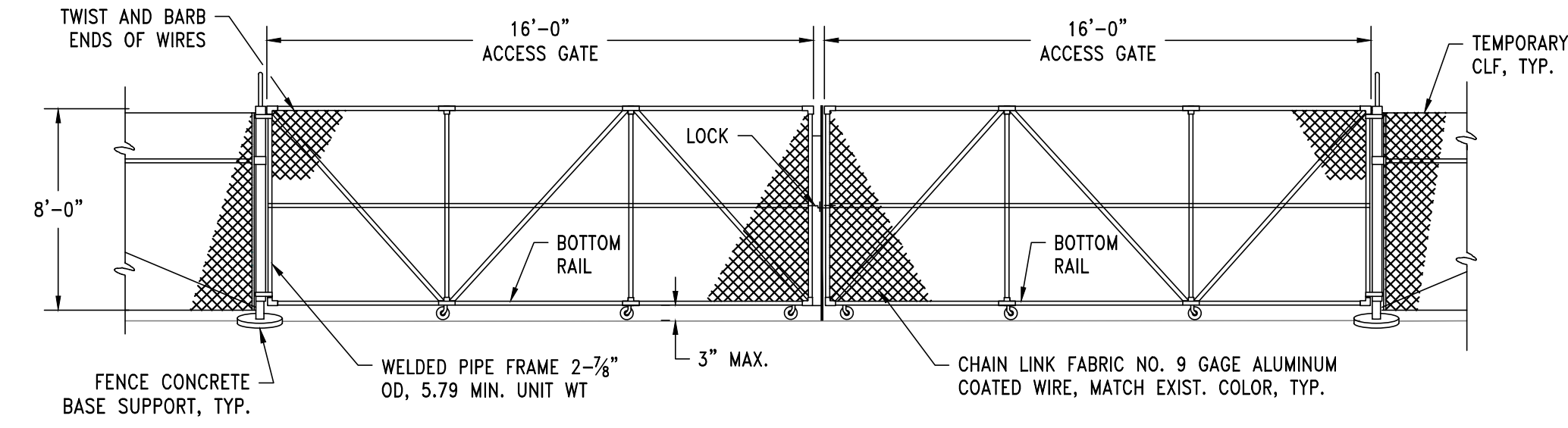

TEMPORARY ROADWAY DOUBLE ACCESS GATE

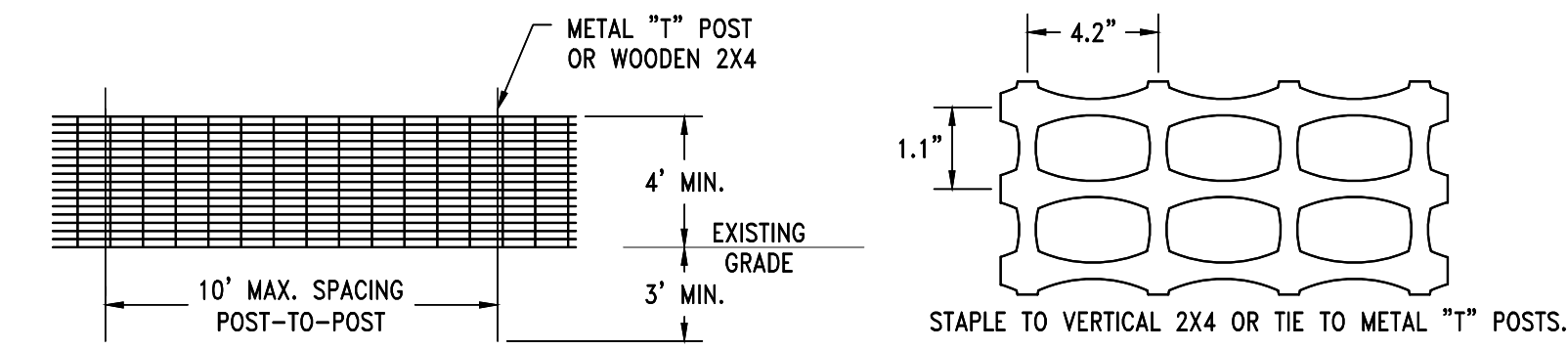

CONSTRUCTION ZONE FENCE

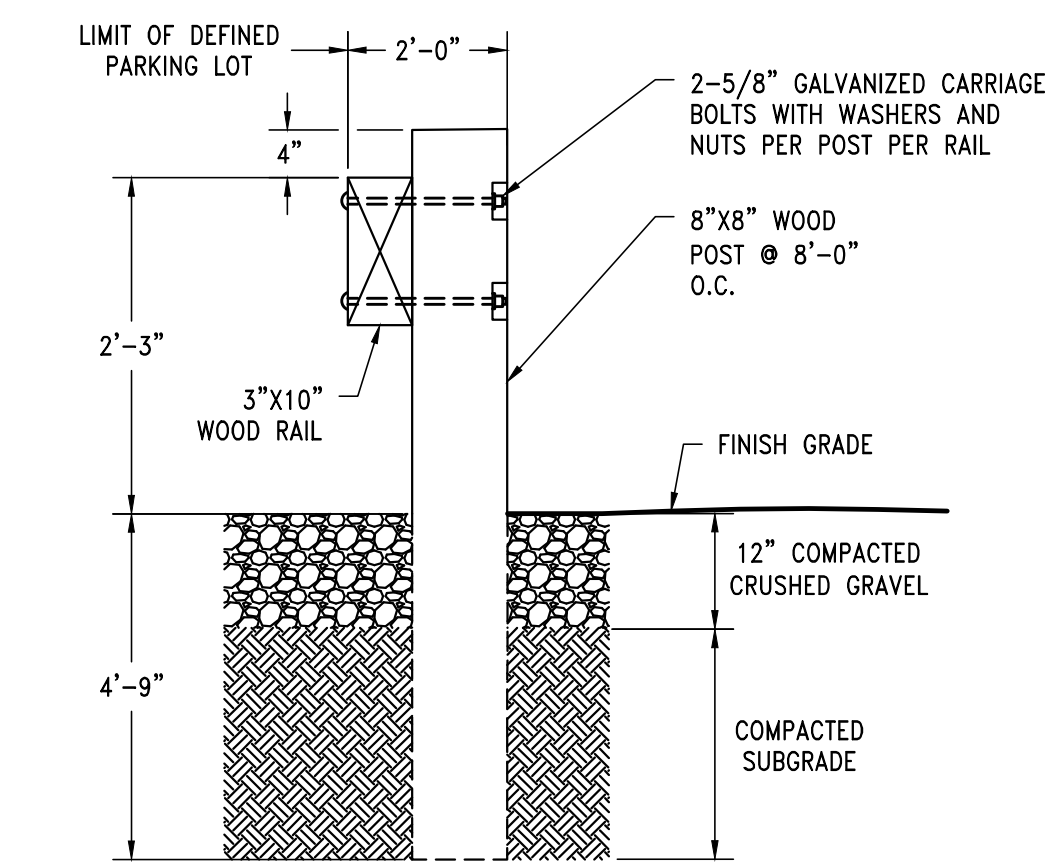
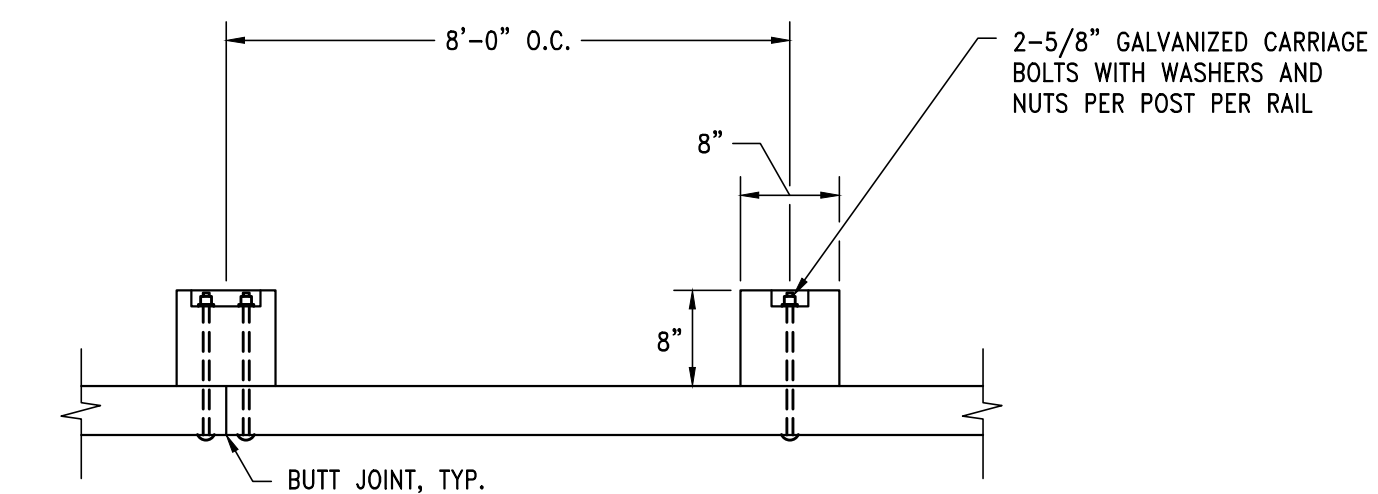

WOOD FENCE

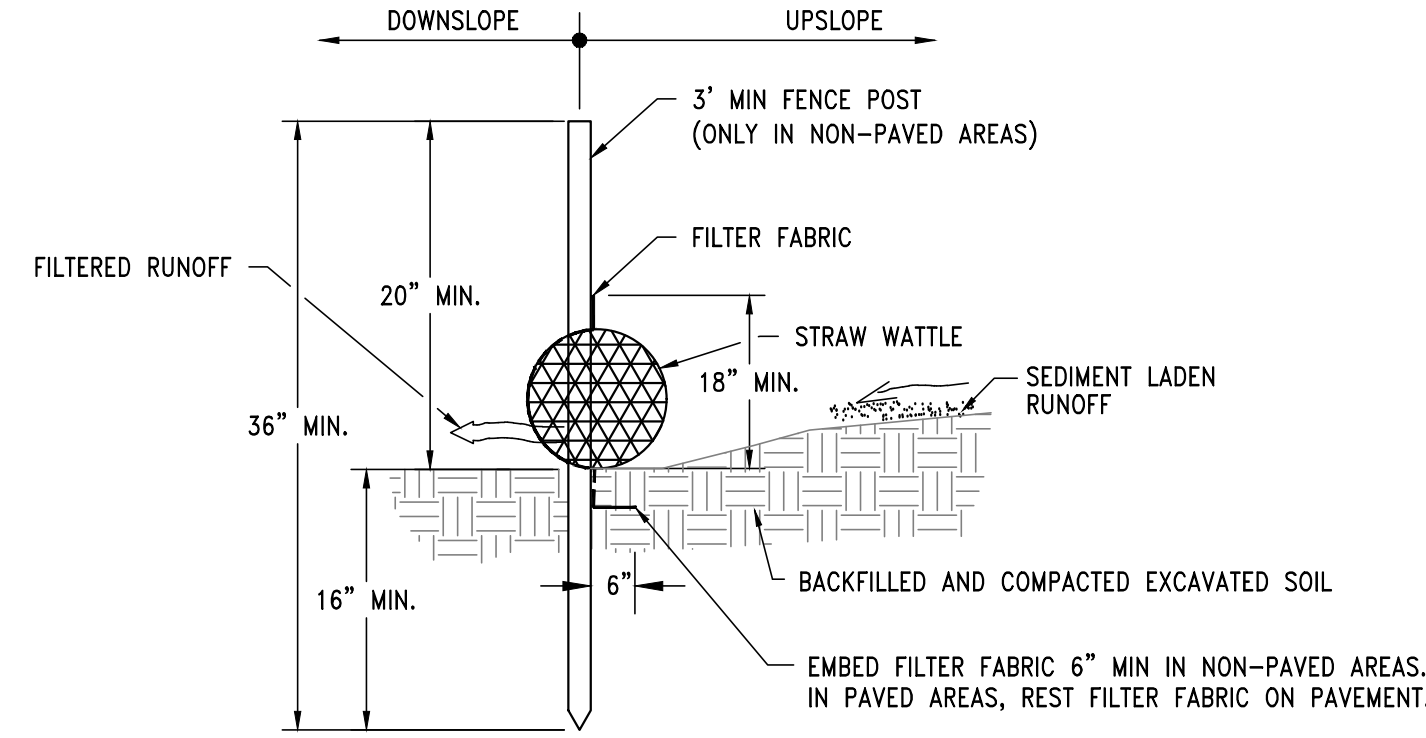
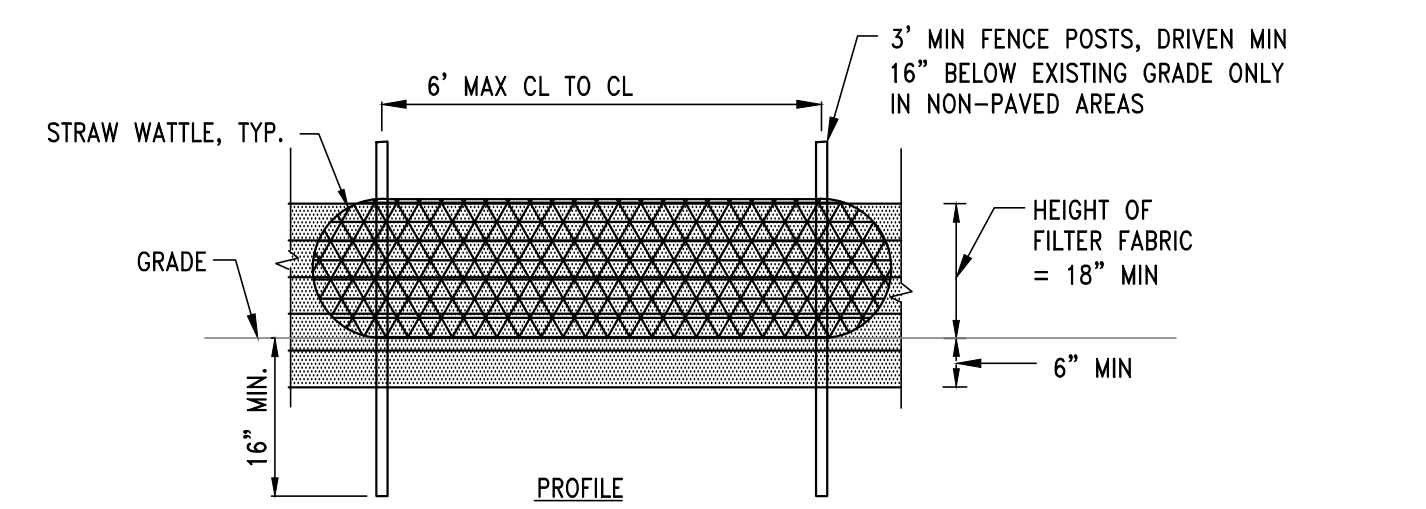

CONSTRUCTION SPECIFICATIONS

1. FILTER FABRIC TO BE FASTENED SECURELY TO TEMPORARY CHAIN LINK FENCE IN PAVED AREAS. TIES SHALL BE SPACED EVERY 12 INCHES AT TOP AND MID SECTION. FILTER FABRIC SHALL BE NO MORE THAN 18-INCHES ABOVE GRADE.
 2. WHEN TWO SECTIONS OF FILTER FABRIC ADJOIN EACH OTHER, THEY SHALL BE OVERLAPPED BY SIX INCHES AND FOLDED.
 3. MAINTENANCE SHALL BE PERFORMED REGULARLY AND MATERIAL REMOVED WHEN BULGES OR HOLES DEVELOP IN THE SILT FENCE, OR AS REQUIRED BY THE ENGINEER.
 4. MAXIMUM ALLOWABLE SLOPE LENGTHS CONTRIBUTING RUNOFF TO A SILT FENCE ARE:
- | SLOPE STEEPNESS | MAXIMUM SLOPE LENGTH (FT) |
|-----------------|---------------------------|
| 2:1 | 25 |
| 3:1 | 50 |
| 4:1 | 75 |
| 5:1 OR FLATTER | 100 |
5. MAXIMUM DRAINAGE AREA FOR OVERLAND FLOW TO A SILT FENCE SHALL NOT EXCEED 1/2 ACRE PER 100 FEET OF FENCE.

SILT FENCE DETAIL

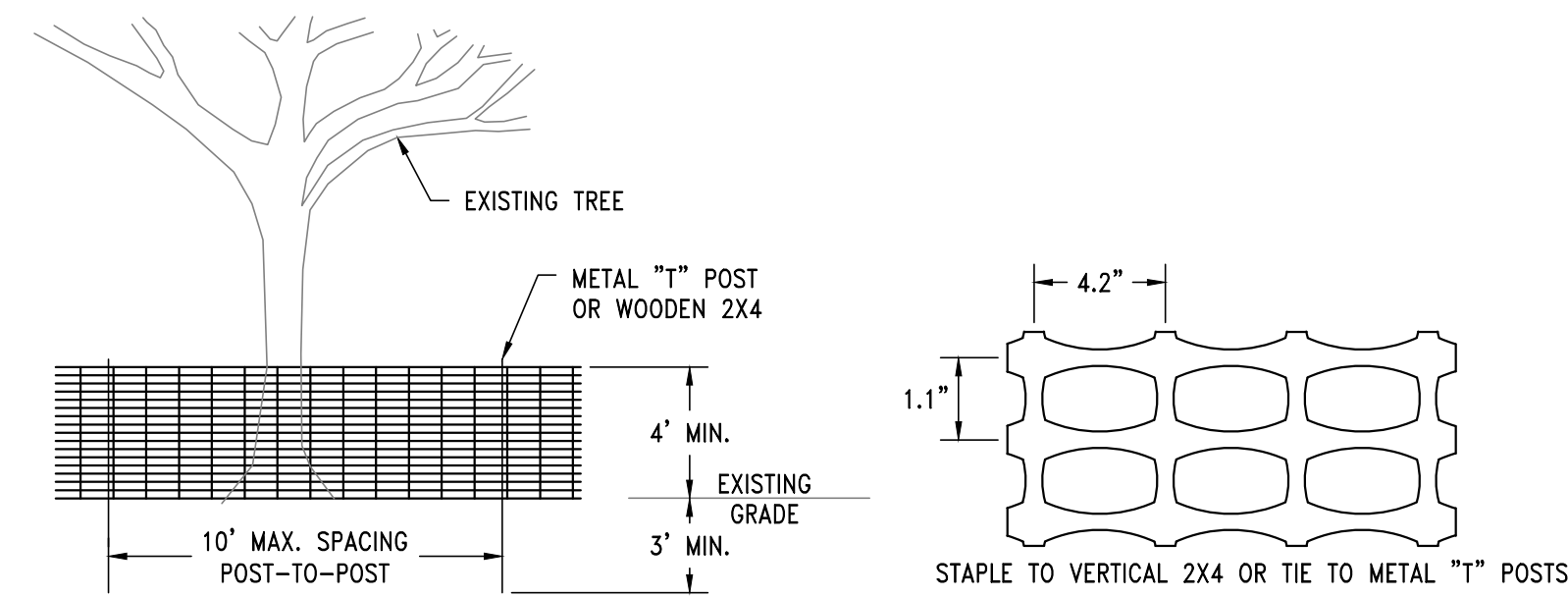

- NOTES:**
1. PLACE CONTINUOUS RUN OF FENCE MATERIAL ON BOTH SIDES OF IMMEDIATE WORK ZONE IN WOODED AREAS AS SHOWN ON THE PLANS. DO NOT ATTACH FENCE MATERIAL TO TREES.
 2. TREE PROTECTION FENCING FABRIC TO BE PLACED AT THE DRIP LINE OF THE TREES THAT ARE TO BE PROTECTED.
 3. ONE SIGN PER 300' OF TREE PROTECTION FENCING SHALL READ: "TREE PROTECTION AREA/DO NOT ENTER AREA/PARA PROTECCION DE LOS ARBOLES/PROHIBIDO ENTRAR".
- MAINTENANCE REQUIREMENTS:**
1. INSPECT WEEKLY, OR INSPECT EVERY 14 DAYS AND AFTER EACH RAINFALL PRODUCING 1/2 INCH OR MORE OF RAIN.
 2. REPAIR OR REPLACE DAMAGED FENCING IMMEDIATELY.
 3. REPLACE ANY DAMAGED SIGNAGE IMMEDIATELY AS NEEDED.
 4. IF ROOTS ARE DAMAGED, CUT OFF DAMAGED AREAS AND PAINT WITH TREE PAINT. SPREAD PEAT MOSS OR MOIST TOPSOIL OVER EXPOSED ROOTS.
 5. REPAIR DAMAGE TO BARK BY TRIMMING AROUND THE DAMAGED AREA, TAPERING CUT TO PROVIDE DRAINAGE. PAINT WITH TREE PAINT.

CONTINUOUS TREE PROTECTION

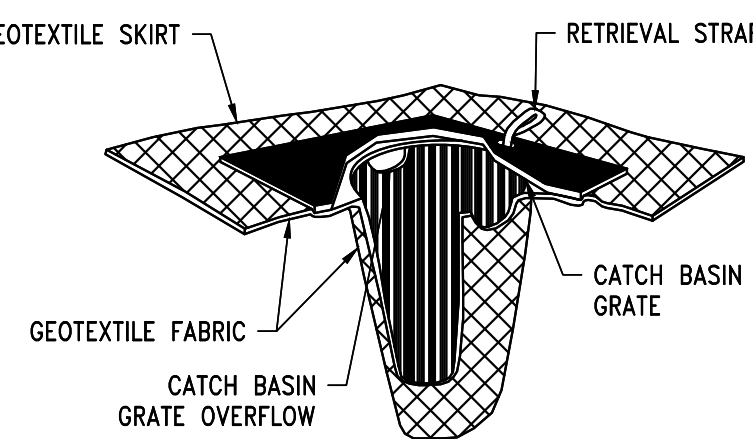

- NOTES:**
1. TO BE INSTALLED IN EXISTING CATCH BASINS WITHIN THE PROJECT LIMITS AS DIRECTED BY THE AUTHORITY.
 2. CONTRACTOR TO VERIFY INLET SIZES PRIOR TO SHOP DRAWING SUBMITTAL.

INLET PROTECTION

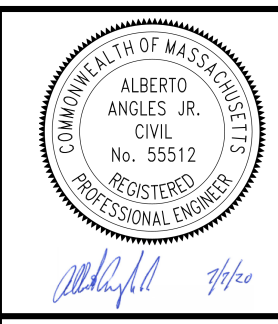

Hazen
HAZEN AND SAWYER
24 FEDERAL STREET, 5TH FLOOR
BOSTON, MASSACHUSETTS 02110

REG. PROF. ENGR. _____ DATE _____
RES. PROF. ENGR. _____ DATE _____

SCALE: AS SHOWN
DESIGNED BY: KTR
DRAWN BY: KTR
CHECKED BY: AA
APPROVED BY: AA

NUMBER	DATE	MADE BY	CHECKED BY	DESCRIPTION

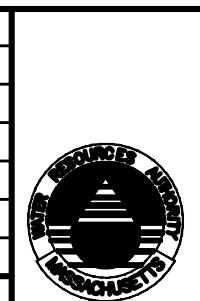

MASSACHUSETTS WATER RESOURCES AUTHORITY
DEER ISLAND TREATMENT PLANT
PARKING LOT MODIFICATIONS
STANDARD DETAILS II

PROJECT NO. _____
CONTRACT NO. 7645
CAD FILE NO. 7645_T04_C-007
SHEET NO. 7645_T04_C-007



ELECTRICAL ABBREVIATIONS

(L/V)CP (LOCAL/VENDOR) CONTROL PANEL
 GND GROUND
 IEEE INSTITUTE OF ELECTRICAL AND ELECTRONICS ENGINEERS
 LTG LIGHTING
 NEMA NATIONAL ELECTRICAL MANUFACTURERS ASSOCIATION
 NFPA NATIONAL FIRE PROTECTION ASSOCIATION
 NTS NOT TO SCALE
 SP. C. SPARE CONDUIT
 TYP TYPICAL

*DESIGNATED ABBREVIATIONS CAN HAVE THE FOLLOWING PREFIXES:
 P POWER

ELECTRICAL LEGEND

LIGHTING:
 POLE-MOUNTED FIXTURE

WIRING:
 CONCRETE ENCASED CONDUIT
 CONDUIT TAGS:
 P DENOTES POWER

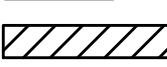
GENERAL:
 LIMITS OF DEMOLITION

ELECTRICAL NOTES:

- UNLESS SPECIFICALLY NOTED OTHERWISE, ALL UNDERGROUND CONCRETE ENCASED ELECTRICAL CONDUITS SHALL BE PER STANDARD DETAIL ON THIS SHEET.
- BOND ALL NEW CONCRETE ENCASED GROUND CONDUCTORS TO EXISTING GROUND CONDUCTORS IN ALL MANHOLES, PULL BOXES, CABLE TRAYS, AND SIMILAR LOCATIONS WHERE APPLICABLE.
- A SEPARATE EQUIPMENT GROUNDING CONDUCTOR SHALL BE PROVIDED FOR EACH CIRCUIT (SEPARATE CONDUCTOR IN THE CONDUIT). THE CONDUCTOR SHALL BE TERMINATED AT THE PROPER DEVICE, TERMINAL, OR LUG AT THE POWER SOURCE. GROUND CONDUCTOR SIZE SHALL BE PER THE LATEST EDITION OF THE NEC.
- UNLESS SPECIFICALLY NOTED OTHERWISE, EXISTING PAVEMENT SHALL BE SAW CUT AND REMOVED TO ALLOW FOR THE INSTALLATION OF NEW ELECTRICAL DUCT BANKS AFTER INSTALLATION, REPLACE PAVEMENT WITH NEW TO MATCH ORIGINAL CONDITIONS.

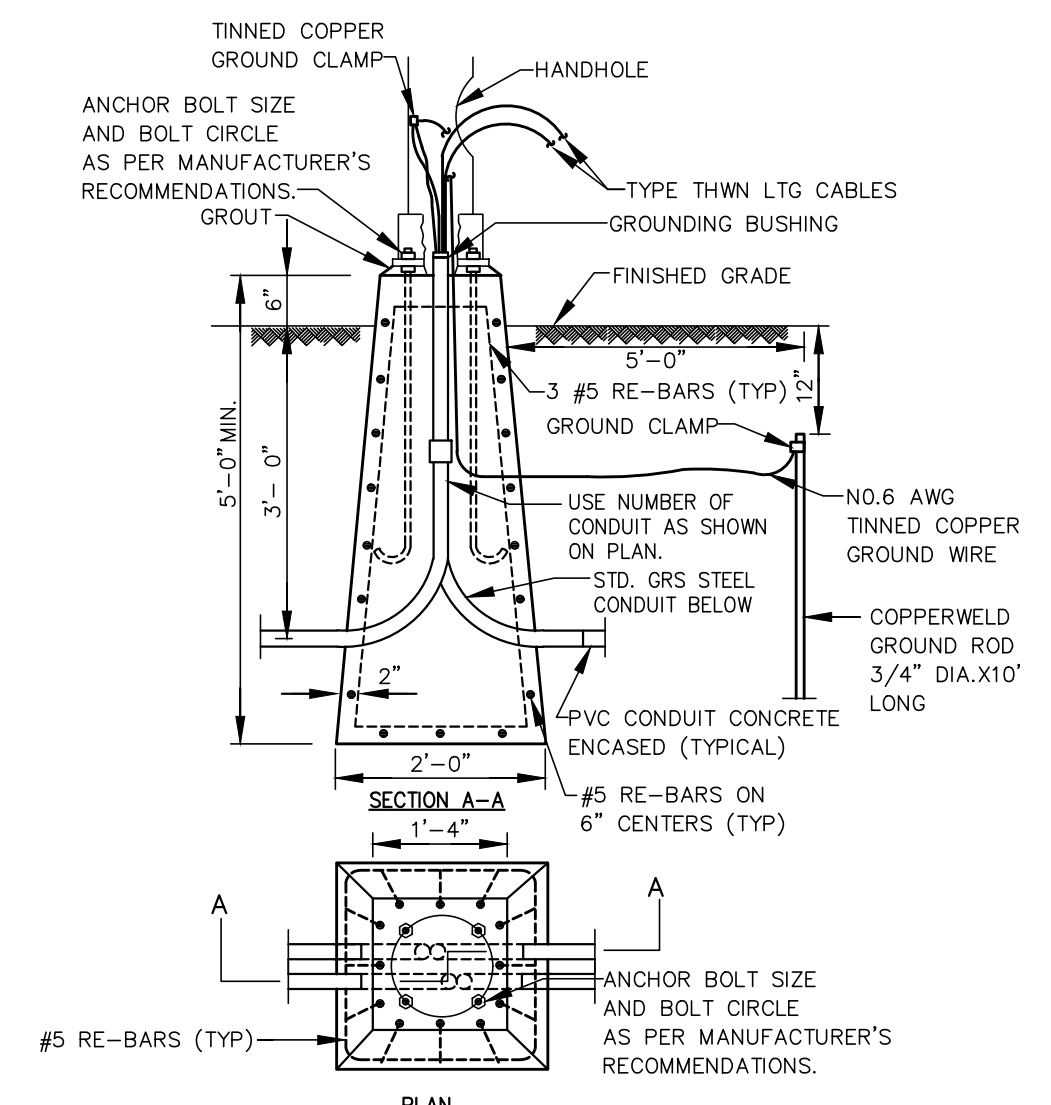

TYPICAL LIGHTING FOUNDATION FOR ROADWAY AND FLOODLIGHTING TO 30'
 N.T.S.

NOTE:
 CIRCUIT GROUND CONDUCTOR AND GROUND ROD, GROUND CONDUCTOR TO BE BONDED TOGETHER AT POLE GROUND CLAMP.

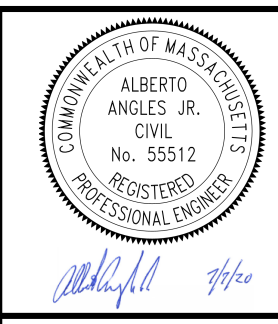

Hazen
 HAZEN AND SAWYER
 24 FEDERAL STREET, 5TH FLOOR
 BOSTON, MASSACHUSETTS 02110

REG. PROF. ENGR. _____ DATE _____
 RES. PROF. ENGR. _____ DATE _____

SCALE: AS SHOWN
UNLESS OTHERWISE NOTED OR CHANGED BY REVISION

DESIGNED BY: DAW					
DRAWN BY: KTR					
CHECKED BY: DAW					
APPROVED BY: DAW					

NUMBER	DATE	MADE BY	CHECKED BY	DESCRIPTION

MASSACHUSETTS WATER RESOURCES AUTHORITY
 DEER ISLAND TREATMENT PLANT

PARKING LOT MODIFICATIONS
 ELECTRICAL LEGEND, ABBREVIATIONS,
 NOTES, AND DETAILS



PROJECT NO.	_____
CONTRACT NO.	7645
CAD FILE NO.	7645_T04_E-001
SHEET NO.	7645_T04_E-001

NOTES:

1. REMOVE EXISTING BRANCH CIRCUIT CONDUCTORS. SAVE UNDERGROUND CONDUITS FOR REUSE.
2. DISCONNECT AND REMOVE EXISTING LIGHT POLE AND SAVE FOR REUSE. REMOVE POLE BASE. EXPOSE EXISTING CONDUIT AND SAVE FOR REUSE.

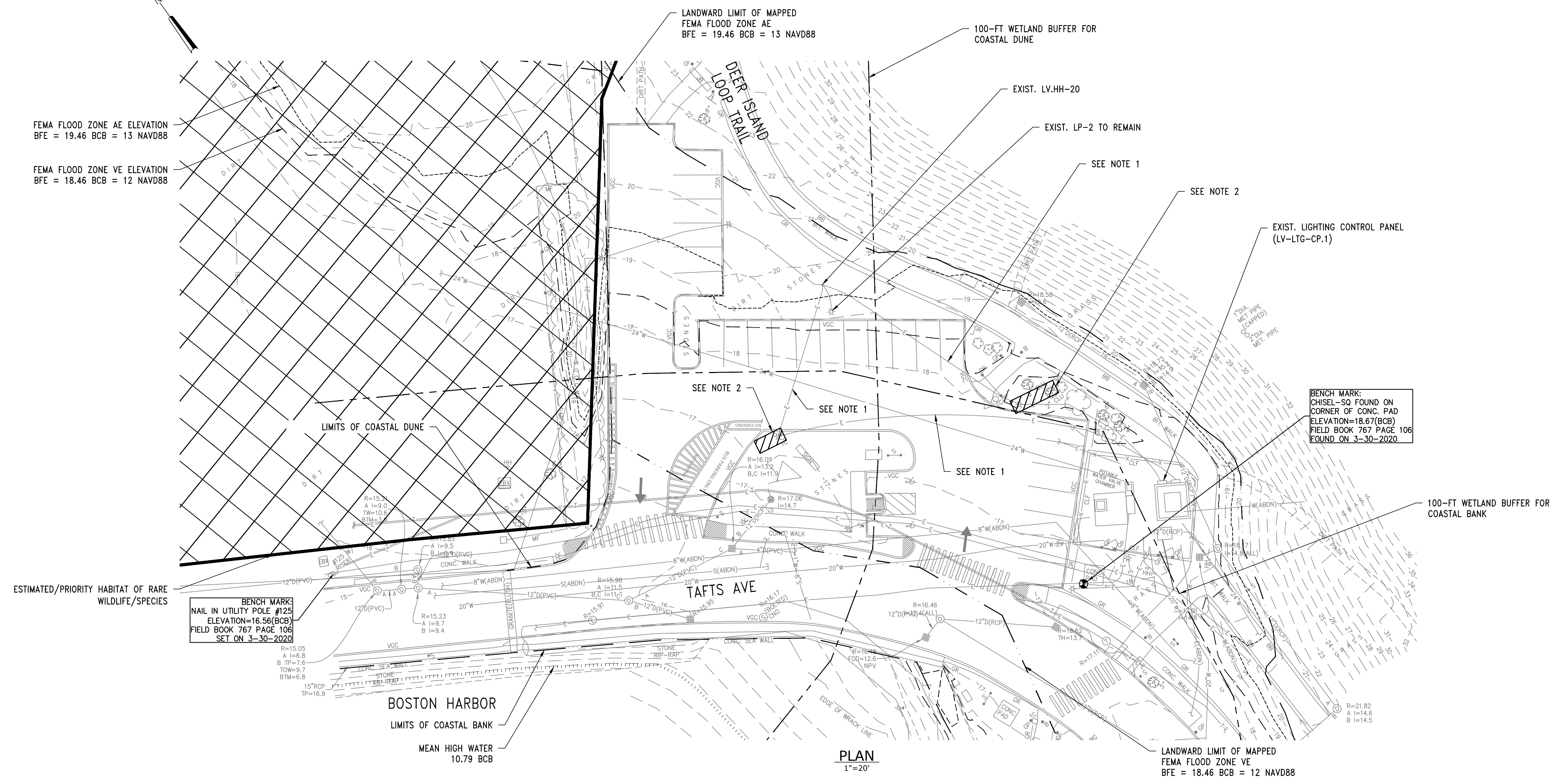

PLAN
1"=20'

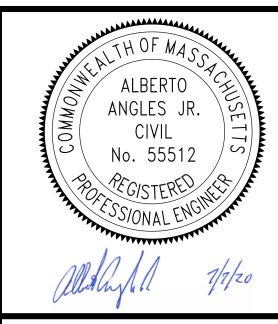
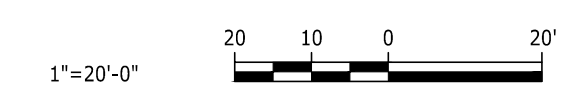

Hazen
HAZEN AND SAWYER
24 FEDERAL STREET, 5TH FLOOR
BOSTON, MASSACHUSETTS 02110

REG. PROF. ENGR. _____ DATE _____
REG. PROF. ENGR. _____ DATE _____

SCALE: AS SHOWN
ALL DIMENSIONS UNLESS NOTED OR CHANGED BY REVISION

DESIGNED BY: DAW
DRAWN BY: KTR
CHECKED BY: DAW
APPROVED BY: DAW

NUMBER	DATE	MADE BY	CHECKED BY	REVISIONS	DESCRIPTION

MASSACHUSETTS WATER RESOURCES AUTHORITY
DEER ISLAND TREATMENT PLANT
PARKING LOT MODIFICATIONS
ELECTRICAL DEMOLITION

PROJECT NO. _____
CONTRACT NO. 7645
CAD FILE NO. 7645_T04_E-002
SHEET NO. 7645_T04_E-002

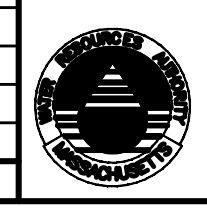

NOTES:

1. EXCAVATE AS REQUIRED TO NEW POLE BASE LOCATION. EXTEND EXISTING CONCRETE ENCASED DUCT BANK WITH 2-1" PVC CONDUITS TO NEW POLE BASE LOCATION. PROVIDE NEW POLE BASE PER DETAIL SHOWN ON SHEET E-01.
2. FURNISH AND INSTALL 4#10, #10 GND BETWEEN LIGHTING CONTROL PANEL LV-LTG-CP-1 AND LP-1.
3. FURNISH AND INSTALL 4#10, #10 GND BETWEEN LP-1 AND LP-2.
4. FURNISH AND INSTALL 4#10, #10 GND BETWEEN LP-2 AND LP-3.

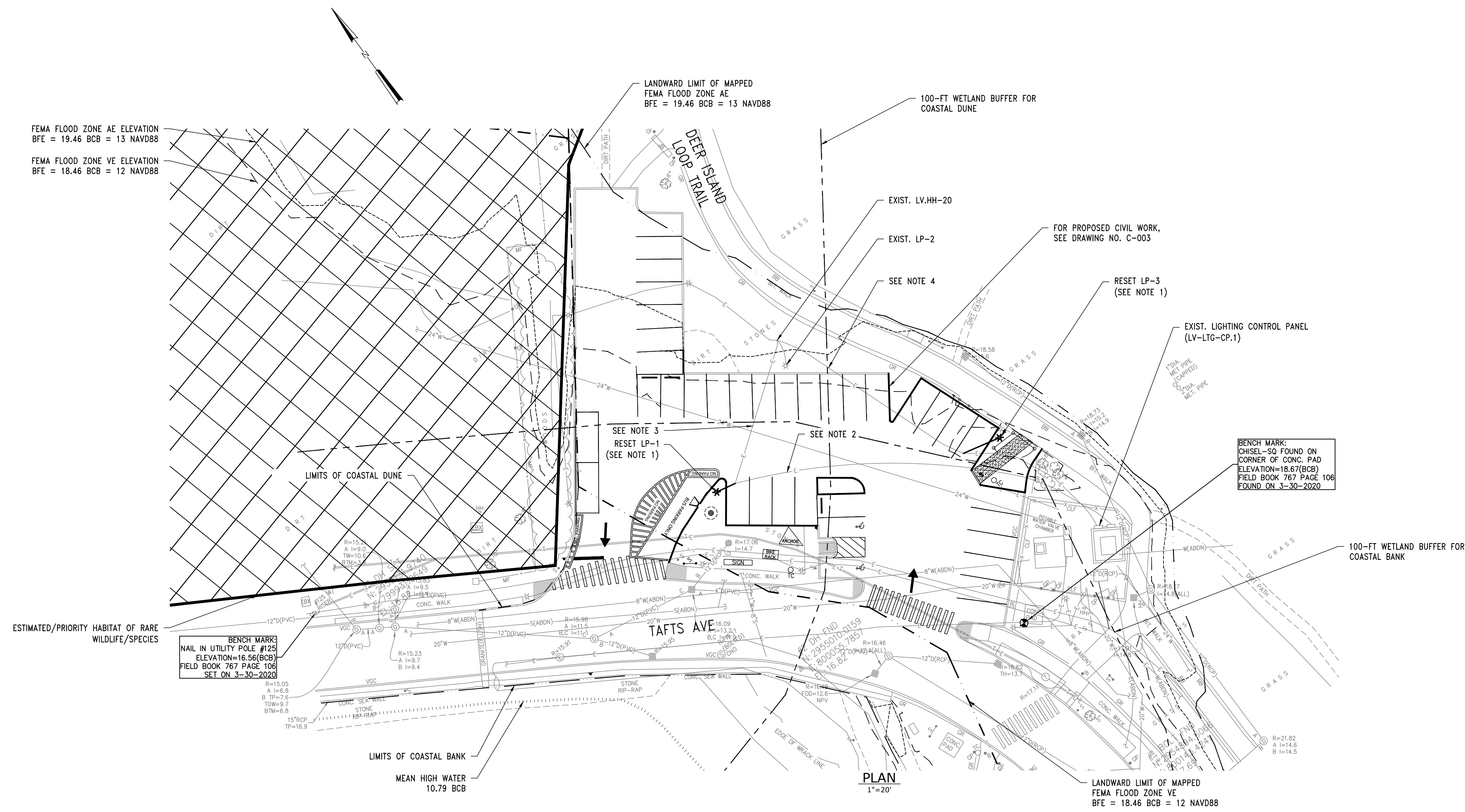

PLAN
1"=20'

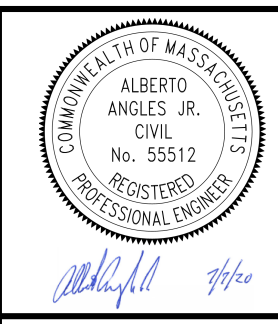
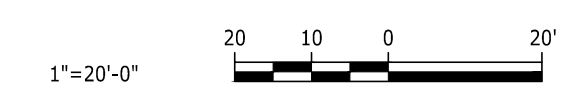

Hazen
HAZEN AND SAWYER
24 FEDERAL STREET, 5TH FLOOR
BOSTON, MASSACHUSETTS 02110

SCALE: AS SHOWN
UNLESS OTHERWISE NOTED OR
CHANGED BY REVISION

DESIGNED BY:	DAW
DRAWN BY:	KTR
CHECKED BY:	DAW
APPROVED BY:	DAW

NUMBER	DATE	MADE BY	CHECKED BY	DESCRIPTION

MASSACHUSETTS WATER RESOURCES AUTHORITY
DEER ISLAND TREATMENT PLANT
PARKING LOT MODIFICATIONS
ELECTRICAL NEW WORK

PROJECT NO. _____
CONTRACT NO. 7645
CAD FILE NO. 7645_T04_E-003
SHEET NO. 7645_T04_E-003

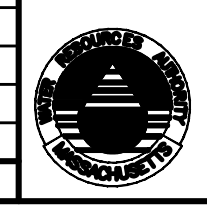

**ATTACHMENT 5
WETLAND RESOURCE AREA ANALYSIS**

**Massachusetts Water Resources Authority
Deer Island Treatment Plant
Parking Lot Modifications
Boston, MA**

April 20, 2020

Email (jcampbell@nitscheng.com)

Mr. Jeffrey Campbell, PLS
Nitsch Engineering
2 Center Plaza, Suite 430
Boston, MA 02108

**Re: Wetland Resource Area Analysis Report
MWRA Deer Island Parking Lot
Tafts Avenue
Boston, Massachusetts**

[LEC File #: NEI\20-058.01]

Dear Mr. Campbell:

As requested, LEC Environmental Consultants, Inc., (LEC) conducted a site evaluation and Wetland Resource Area Analysis associated with the *Deer Island Parking Lot* off Tafts Avenue on Deer Island in Boston, Massachusetts. LEC identified and characterized Wetland Resource Area boundaries in the vicinity of the *Parking Lot* in the context of a potential parking expansion project, and has prepared the following report summarizing our findings.

The existing conditions and wetland boundaries are depicted on the *Existing Conditions Plan*, prepared by Nitsch Engineering, dated April 20, 2020. The wetland boundary determination and findings described in this report are based on the *Massachusetts Wetlands Protection Act* (“WPA”; M.G.L. c. 131, s. 40) and its implementing Regulations (“WPA Regulations”; 310 CMR 10.00), and the *City of Boston Local Wetlands Ordinance (Ordinance)*. The City of Boston has drafted implementing Regulations but they have not been officially adopted as of this writing. Additional environmental regulations and permitting considerations are discussed in the Regulatory Implications section.

The following report provides a General Site Description, a description of the Wetland Resource Areas, and a Regulatory Implications Analysis.

General Site Description

The site evaluation and wetland boundary determination was focused on the *Deer Island Parking Lot* and surrounding areas located off Tafts Avenue on Deer Island in Boston, Massachusetts (Attachment A, Figures 1 and 2).

Deer Island is a 265-acre peninsula extending southeasterly from the town of Winthrop into Boston Harbor. Prior to the hurricane of 1938, Deer Island was separated from the mainland by a narrow waterway known as “Shirley Gut” but has been connected to the mainland since coastal erosion from the



storm filled the waterway. Deer Island is home to the Deer Island Waste Water Treatment Plant located primarily on the southeastern end of the peninsula and operated by the Massachusetts Water Resource Authority (MWRA). The northwestern end of the peninsula, including the *Parking Lot*, is recreational parkland with open fields, rolling hills, and paved paths which begin at the *Parking Lot* and extend around the island perimeter. The wastewater treatment facility occupies two thirds of the island while the parklands and intertidal areas occupy the remaining third. The parkland portions of the island are part of the Boston Harbor Islands National Recreation Area operated by the National Park Service.

The *Parking Lot* contains approximately 26 parking spaces, and is utilized by the public primarily for access to the network of walking paths on Deer Island. Privately owned property to the northwest of the parking lot contains an open field with various grasses and herbaceous vegetation that was recently mowed at the time of our evaluation on April 1, 2020. A four foot tall metal fence extends along the maintained limits of the parking lot area, which at the time of our evaluation was presumed to be coincident with the property line. Subsequent to our evaluation, it was determined that the actual property line is located within the open field area, as depicted on the *Existing Conditions Plan*. The City of Boston/Town of Winthrop municipal boundary is located just west of the property line on the private property.

Floodplain Designation

According to the March 16, 2016 FEMA Flood Insurance Rate Map (FEMA FIRM) for the Town of Boston (*Community Panel 25025 C 0102J*), the *Parking Lot* appears to be mapped within a Zone AE (el. 13) – *Special Flood Hazard Areas subject to inundation by the 1% annual chance flood; base flood elevations determined* and immediately adjacent to a VE Zone (el. 13) (Attachment A, Figure 3). The VE Zone as mapped by FEMA, extends along the northwesterly limits of the parking lot and then turns south across the paved entrance from Tafts Avenue, as depicted on the *Existing Conditions Plan*.

Natural Heritage and Endangered Species Program Designation

According to the 14th Edition (August 1, 2017) of the *Massachusetts Natural Heritage Atlas* published by the Natural Heritage & Endangered Species Program (NHESP), the existing *Parking Lot* itself is not located within a *Priority Habitat of Rare Species* or *Estimated Habitat of Rare Wildlife*; however, areas immediately adjacent to the north/northwest of the *Parking Lot* are located within these mapped habitats (Attachment A, Figure 4).

Wetland Resource Areas

Wetland Resource Areas associated with the project area include Coastal Beach, Coastal Dune, Coastal Bank, Land Subject to Coastal Storm Flowage (LSCSF) and potentially Barrier Beach. Intertidal and subtidal areas to the northeast and southwest also contain Land Under the Ocean and Land Containing Shellfish; however, these areas are not described herein since they are located beyond the survey area. A brief description of the relevant Wetland Resource Areas is provided below.

Coastal Beach

Coastal Beach is defined in 310 CMR 10.27(2) as *unconsolidated sediment subject to wave, tidal and coastal storm action which forms the gently sloping shore of a body of salt water and includes tidal flats*.



Coastal beaches extend from the mean low water line landward to the dune line, coastal bankline or the seaward edge of existing human-made structures, when these structures replace one of the above lines, whichever is closest to the ocean.

Coastal Beach is located approximately 200 feet to the northeast of *Parking Lot*. The beach is composed of coarse to medium sand with numerous cobbles and stones. Coastal Beach is also located across Tafts Avenue downgradient from the seawall. The beach in this area is dominated by pebbles, small stones and cobbles.

Coastal Dune

Coastal Dune is defined at 310 CMR 10.28(2) as *any natural hill, mound or ridge of sediment landward of a coastal beach deposited by wind action or storm overwash. Coastal dune also means sediment deposited by artificial means and serving the purpose of storm damage prevention or flood control.*

The Coastal Dune is located upgradient of the Coastal Beach to the northeast of the *Parking Lot* and to the north/northwest, extending onto the private property. Although the private property and land beyond the fence was not evaluated, it appears to meet the definition of Coastal Dune as it is dominated by artificial fill, is within the V-Zone and subject to storm overwash, and is mapped as both a Barrier Beach and Coastal Dune according to MassGIS (Attachment A, Figure 5). The seaward portion of the Coastal Dune located just upgradient of the Coastal Beach is vegetated with American beachgrass (*Ammophila breviligulata*), and other unidentified grasses, while the undeveloped property to the north/northwest has been recently mowed and vegetation identification was not possible.

Coastal Bank

Coastal Bank is defined at 310 CMR 10.30(2) as *the seaward face or side of any elevated landform, other than a coastal dune, which lies at the landward edge of a coastal beach, land subject to tidal action, or other wetland.*

Coastal Bank is associated with the vertical seawall and rip-rap slope along the southwest side of Tafts Avenue.

Land Subject to Coastal Storm Flowage (LSCSF)

Land Subject to Coastal Storm Flowage (LSCSF) is defined at 310 CMR 10.04 as *land subject to any inundation caused by coastal storms up to and including that caused by the 100-year storm, surge of record or storm of record, whichever is greater.*

According to the March 16, 2016 FEMA FIRM for the Town of Boston (*Community Panel 25025 C 0102J*), the *Parking Lot* is mapped within a Zone AE (el. 13) and immediately adjacent to a VE Zone (el. 13) (Attachment A, Figure 3). LSCSF is coincident with the extent of mapped floodplain on and adjacent to the *Parking Lot*.

In addition to LSCSF, the *Ordinance* protects the *Coastal Flood Resilience Zone* or (*CFRZ*), which is defined as *the area of land beyond the current boundary of land subject to coastal storm flowage or land subject to tidal action that the Commission determines has a reasonable probability of becoming subject to future coastal storm flowage or tidal action due to sea level rise (SLR) within approximately the next 50 years. The "coastal flood resilience zone" as delineated on maps adopted by the Commission may be*



periodically reviewed and revised by the Commission, and may be divided into sub-zones with different regulatory requirements.

As noted above, the *Ordinance Regulations* are currently drafted for public comment but have not been formally adopted. Since the site and surrounding areas are within LSCSF it

Barrier Beach

Barrier Beach is defined in 310 CMR 10.29 (2) as *a narrow low-lying strip of land generally consisting of coastal beaches and coastal dunes extending roughly parallel to the trend of the coast. It is separated from the mainland by a narrow body of fresh, brackish or saline water or a marsh system. A barrier beach may be joined to the mainland at one or both ends.*

There is some uncertainty regarding the presence of a Barrier Beach associated with the undeveloped land adjacent to the north/northwest of the *Parking Lot*. According to MassGIS datalayer (Attachment A, Figure 5) the area is mapped as a Barrier Beach. However, the area is not mapped as a Barrier Beach on the Massachusetts Barrier Beach Inventory from the Massachusetts Office of Coastal Zone Management (CZM). If the area is considered a Barrier Beach, the lateral boundary of the Barrier Beach closest to the *Parking Lot* has been delineated coincident with the limits of the V-Zone and Coastal Dune, as described below. Further consultation with CZM is recommended definitively determine the presence/absence of Barrier Beach.

Regulatory Implications

The following analysis addresses the environmental permitting considerations associated with improvements to the *Parking Lot*. While the scope of the proposed project is unclear, any project which expands or substantially reconfigures the *Parking Lot* may require environmental permitting. The following presumes that any project will involve some level of land disturbance beyond the existing footprint of pavement.

WPA Regulations and Boston Local Wetlands Ordinance

Since the entire *Parking Lot* is within LSCSF, any disturbances beyond the existing limit of pavement will require filing with the Boston Conservation Commission seeking an Order of Conditions (OOC) or Determination of Applicability (DOA). If the project extends into NHESP Mapped habitat, a copy of the NOI should be sent to NHESP and pre-filing consultation may be warranted, as noted below. The Boston Conservation Commission is in the process of adopting Regulations to accompany the Ordinance. These Regulations should be reviewed by the project team during project design.

Massachusetts Endangered Species Act (MESA)

If the project extends into NHESP mapped habitat, pre-filing consultation is recommended to determine if the project will require permitting under the *Massachusetts Endangered Species Act* (MESA, M.G.L. c. 131A) and its implementing *Regulations* (321 CMR 10.00).

Massachusetts Environmental Policy Act (MEPA)

MEPA review under the *MEPA Regulations* (301 CMR 11.00) may be triggered since MEPA jurisdiction is triggered when a project will involve state funding. In this case, the property is owned by the



Commonwealth; therefore, state funding is presumed. While state funding establishes MEPA jurisdiction, MEPA review of the project would only be triggered if the project exceeds any of the threshold at 301 CMR 11.03.

Chapter 91 Waterways Regulations

The *Parking Lot* and surrounding areas are within the Historic High Water (HHW) line (Appendix A, Figure 6). Any project activities would be located below the HHW line, and thus subject to Chapter 91 jurisdiction under the *Public Waterfront Act* (Chapter 91, Section 10) and its associated *Regulations* (310 CMR 9.00). Review of existing Licenses/Permits for the *Parking Lot* and pre-filing coordination with DEP Waterways staff is recommended.

401 Water Quality Certification

Given the characterization of resource areas and likely scope of work for the *Parking Lot* improvement project, it appears unlikely that that the work would trigger review under the *401 Water Quality Certification Regulations* (314 CMR 9.00) and specifically, under 314 CMR 9.04: *Activities Requiring an Application*.

Federal Clean Water Act

It is unlikely that project activities will occur within jurisdiction of the *Clean Water Act* (33 U.S.C. §1251 et seq.) since jurisdiction is limited to areas below the High Tide Line (HTL). The HTL is located approximately 200 feet from the *Parking Lot* to the north and across Tafts Avenue to the southwest. There are no other jurisdictional wetlands or Waters of the United States located in close proximity to the *Parking Lot*.

Summary

LEC identified and delineated the boundaries of Wetland Resource Areas associated with the *Deer Island Parking Lot*, as protected under the *Massachusetts Wetlands Protection Act* (M.G.L. c. 131, s. 40) and its implementing Regulations (310 CMR 10.00), and the *City of Boston Wetlands Ordinance*. Any projects that expand upon or substantially reconfigure the parking area will filing an NOI with the Boston Conservation Commission, and may require a Chapter 91 filing with DEP, NHESP review, and/or, a MEPA filing.

We appreciate the opportunity to work with you on this project. If you have any questions or require additional information, please do not hesitate to contact me at (508) 746-9491 or at mmanganello@lecenvironmental.com.

Sincerely,

LEC Environmental Consultants, Inc.

Mark L. Manganello

Assistant Director of Ecological Services

Attachments

Attachment A

Locus Maps

Figure 1: Aerial Orthophoto Map

Figure 2: USGS Topographic Quadrangle

Figure 3: FEMA Flood Insurance Rate Map

Figure 4: NHESP Map

Figure 5: MassGIS Map

Figure 6 Historic High Water Map



2013 Aerial Orthophoto acquired from the Office of Geographic Information (MassGIS) website.



LEC Environmental Consultants, Inc.

Plymouth, MA
508.746.9491
www.lecenvironmental.com

Figure 1: Aerial Orthophoto Map

Deer Island
Boston, Massachusetts



February 21, 2020

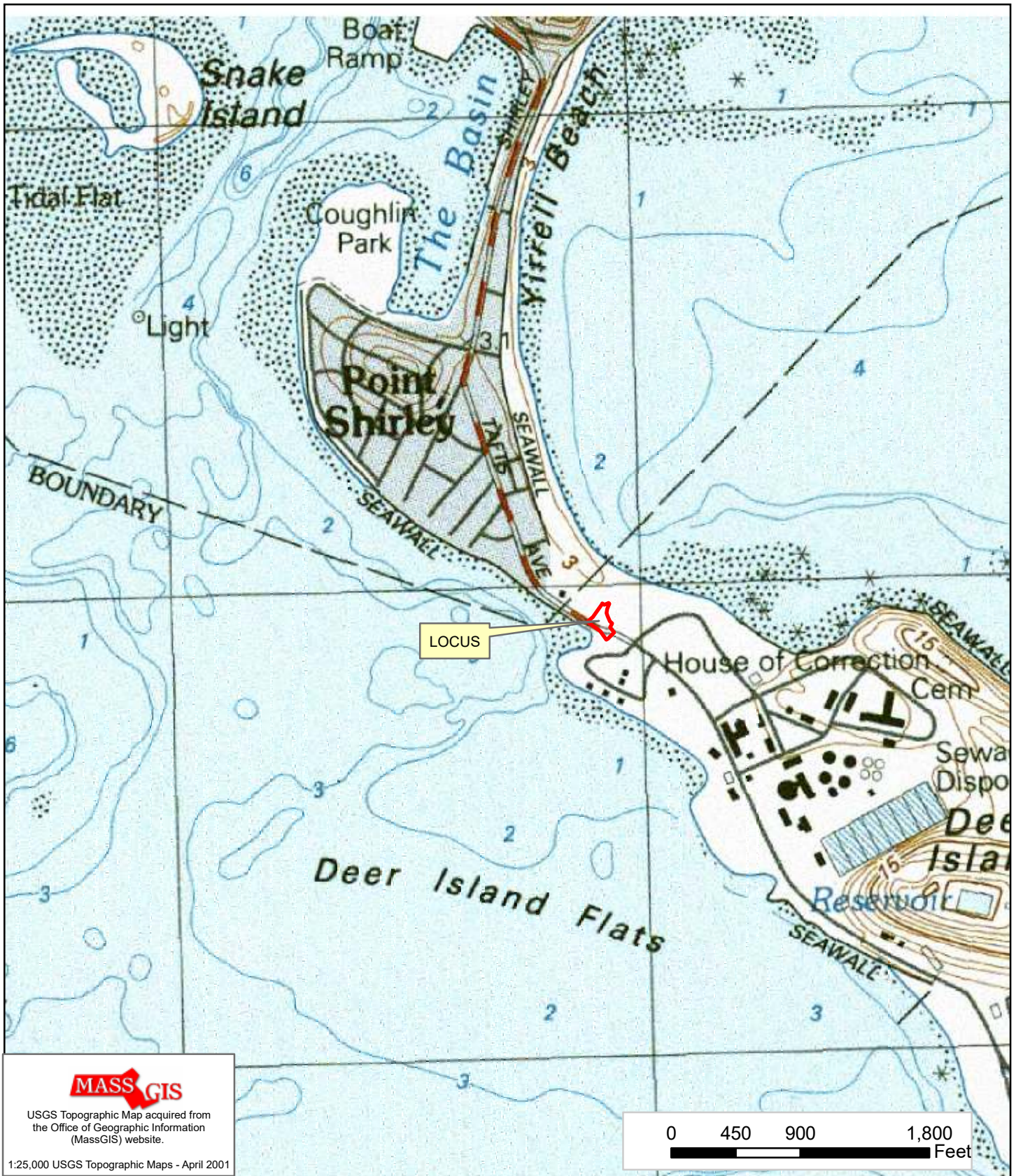

Figure 2: USGS Topographic Map
Deer Island
Boston, Massachusetts

Figure 3: National Flood Hazard Layer FIRMette



Legend

SEE FIS REPORT FOR DETAILED LEGEND AND INDEX MAP FOR FIRM PANEL LAYOUT

SPECIAL FLOOD HAZARD AREAS		Without Base Flood Elevation (BFE) Zone A, V, A99
		With BFE or Depth Zone AE, AO, AH, VE, AR
		Regulatory Floodway

OTHER AREAS OF FLOOD HAZARD		0.2% Annual Chance Flood Hazard, Areas of 1% annual chance flood with average depth less than one foot or with drainage areas of less than one square mile Zone X
		Future Conditions 1% Annual Chance Flood Hazard Zone X
		Area with Reduced Flood Risk due to Levee. See Notes. Zone X
		Area with Flood Risk due to Levee Zone D

OTHER AREAS		NO SCREEN Area of Minimal Flood Hazard Zone X
		Effective LOMRs
GENERAL STRUCTURES		Channel, Culvert, or Storm Sewer
		Levee, Dike, or Floodwall

OTHER FEATURES		20.2 Cross Sections with 1% Annual Chance
		17.5 Water Surface Elevation
		Coastal Transect
		Base Flood Elevation Line (BFE)
		Limit of Study
		Jurisdiction Boundary
OTHER FEATURES		Coastal Transect Baseline
		Profile Baseline
		Hydrographic Feature

MAP PANELS		Digital Data Available
		No Digital Data Available
		Unmapped

The pin displayed on the map is an approximate point selected by the user and does not represent an authoritative property location.

This map complies with FEMA's standards for the use of digital flood maps if it is not void as described below. The basemap shown complies with FEMA's basemap accuracy standards

The flood hazard information is derived directly from the authoritative NFHL web services provided by FEMA. This map was exported on 2/21/2020 at 10:33:11 AM and does not reflect changes or amendments subsequent to this date and time. The NFHL and effective information may change or become superseded by new data over time.

This map image is void if the one or more of the following map elements do not appear: basemap imagery, flood zone labels, legend, scale bar, map creation date, community identifiers, FIRM panel number, and FIRM effective date. Map images for unmapped and unmodernized areas cannot be used for regulatory purposes.

42°21'30.39"N

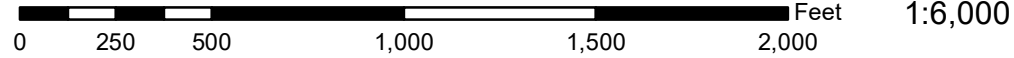

USGS The National Map: Orthoimagery, Data refreshed April, 2019.

42°21'3.80"N



0 250 500 1,000 1,500 2,000 Feet

70°58'22.74"W

70°57'45.28"W

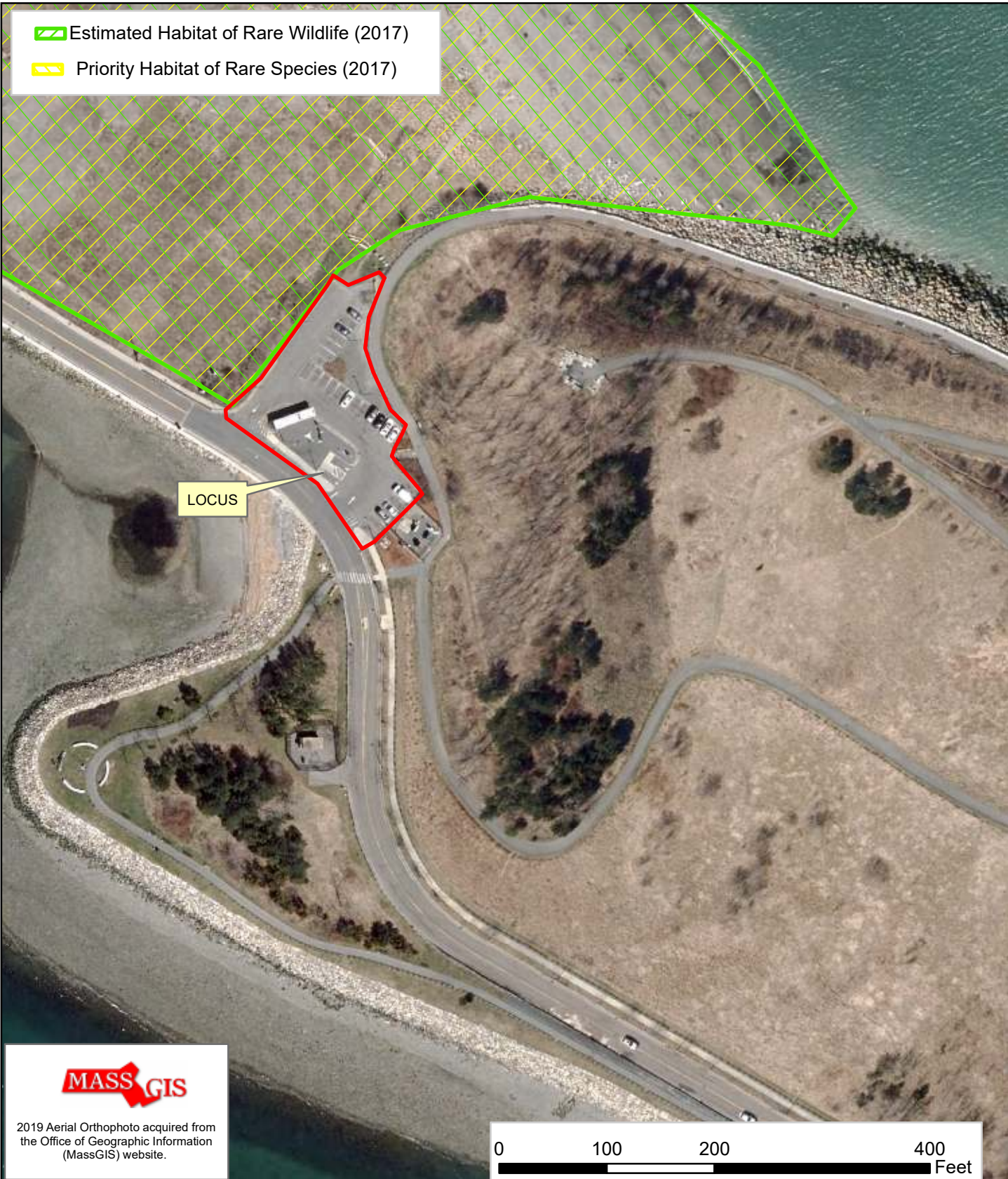



 Estimated Habitat of Rare Wildlife (2017)
 Priority Habitat of Rare Species (2017)

LOCUS

 2019 Aerial Orthophoto acquired from
 the Office of Geographic Information
 (MassGIS) website.

0 100 200 400 Feet

 LEC Environmental Consultants, Inc.
 Plymouth, MA
 508.746.9491
 www.lecenvironmental.com

Figure 4: NHESP Map
 Deer Island
 Boston, Massachusetts

 April 20, 2020

4/20/2020

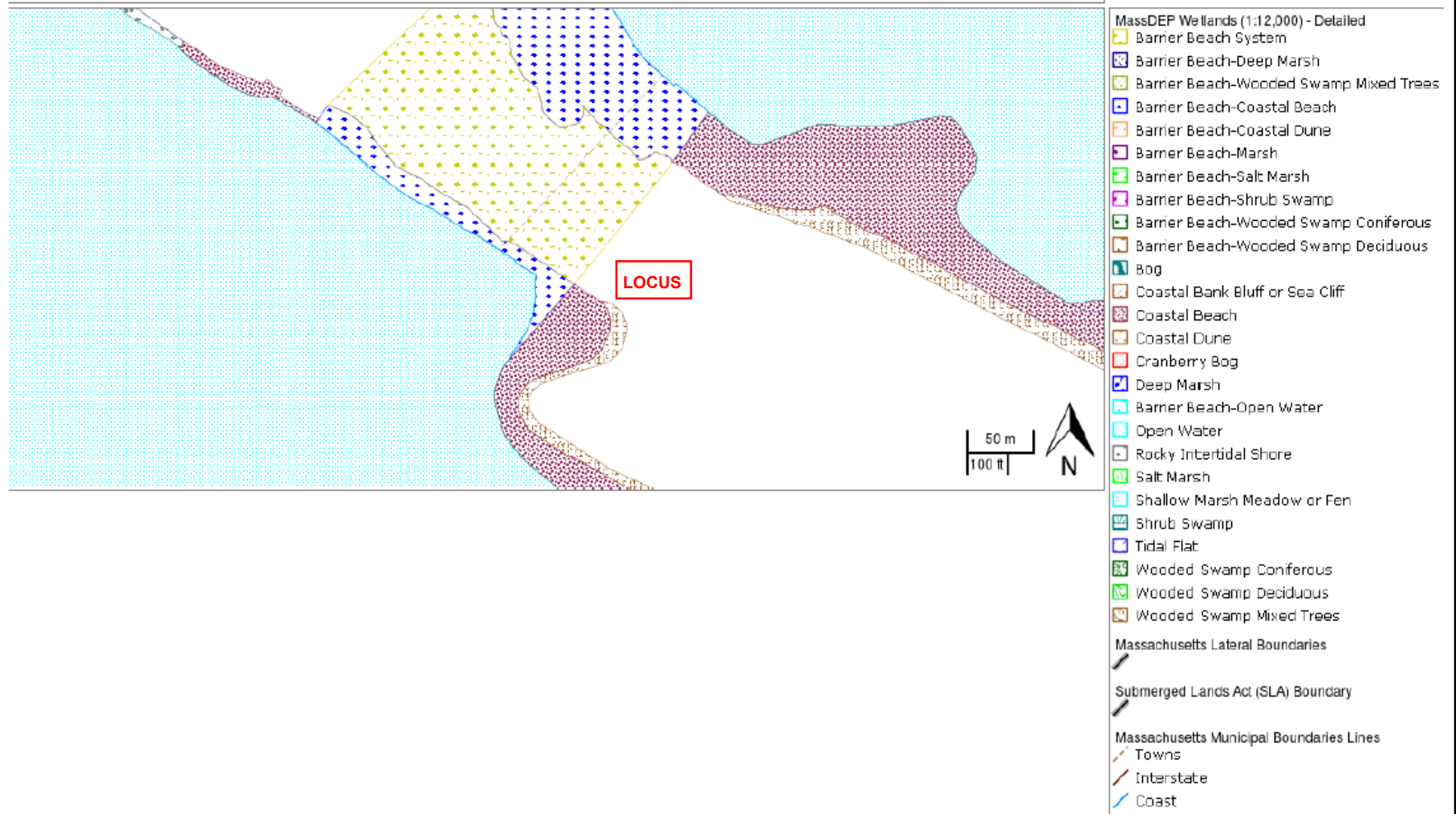

LEC Environmental Consultants, Inc.

Plymouth, MA
508.746.9491

www.lecenvironmental.com

Figure 5: MassGIS Wetlands Map

Deer Island
Boston, Massachusetts



April 20, 2020



 2019 Aerial Orthophoto acquired from
 the Office of Geographic Information
 (MassGIS) website.

 LEC Environmental Consultants, Inc.
 Plymouth, MA
 508.746.9491
 www.lecenvironmental.com

Figure 6: Aerial Historic High Water Map
 Deer Island
 Boston, Massachusetts

 April 17, 2020

**ATTACHMENT 6
STORMWATER REPORT**

**Massachusetts Water Resources Authority
Deer Island Treatment Plant
Parking Lot Modifications
Boston, MA**



Checklist for Stormwater Report

A. Introduction

Important: When filling out forms on the computer, use only the tab key to move your cursor - do not use the return key.



A Stormwater Report must be submitted with the Notice of Intent permit application to document compliance with the Stormwater Management Standards. The following checklist is NOT a substitute for the Stormwater Report (which should provide more substantive and detailed information) but is offered here as a tool to help the applicant organize their Stormwater Management documentation for their Report and for the reviewer to assess this information in a consistent format. As noted in the Checklist, the Stormwater Report must contain the engineering computations and supporting information set forth in Volume 3 of the [Massachusetts Stormwater Handbook](#). The Stormwater Report must be prepared and certified by a Registered Professional Engineer (RPE) licensed in the Commonwealth.

The Stormwater Report must include:

- The Stormwater Checklist completed and stamped by a Registered Professional Engineer (see page 2) that certifies that the Stormwater Report contains all required submittals.¹ This Checklist is to be used as the cover for the completed Stormwater Report.
- Applicant/Project Name
- Project Address
- Name of Firm and Registered Professional Engineer that prepared the Report
- Long-Term Pollution Prevention Plan required by Standards 4-6
- Construction Period Pollution Prevention and Erosion and Sedimentation Control Plan required by Standard 8²
- Operation and Maintenance Plan required by Standard 9

In addition to all plans and supporting information, the Stormwater Report must include a brief narrative describing stormwater management practices, including environmentally sensitive site design and LID techniques, along with a diagram depicting runoff through the proposed BMP treatment train. Plans are required to show existing and proposed conditions, identify all wetland resource areas, NRCS soil types, critical areas, Land Uses with Higher Potential Pollutant Loads (LUHPPL), and any areas on the site where infiltration rate is greater than 2.4 inches per hour. The Plans shall identify the drainage areas for both existing and proposed conditions at a scale that enables verification of supporting calculations.

As noted in the Checklist, the Stormwater Management Report shall document compliance with each of the Stormwater Management Standards as provided in the Massachusetts Stormwater Handbook. The soils evaluation and calculations shall be done using the methodologies set forth in Volume 3 of the Massachusetts Stormwater Handbook.

To ensure that the Stormwater Report is complete, applicants are required to fill in the Stormwater Report Checklist by checking the box to indicate that the specified information has been included in the Stormwater Report. If any of the information specified in the checklist has not been submitted, the applicant must provide an explanation. The completed Stormwater Report Checklist and Certification must be submitted with the Stormwater Report.

¹ The Stormwater Report may also include the Illicit Discharge Compliance Statement required by Standard 10. If not included in the Stormwater Report, the Illicit Discharge Compliance Statement must be submitted prior to the discharge of stormwater runoff to the post-construction best management practices.

² For some complex projects, it may not be possible to include the Construction Period Erosion and Sedimentation Control Plan in the Stormwater Report. In that event, the issuing authority has the discretion to issue an Order of Conditions that approves the project and includes a condition requiring the proponent to submit the Construction Period Erosion and Sedimentation Control Plan before commencing any land disturbance activity on the site.



Checklist for Stormwater Report

B. Stormwater Checklist and Certification

The following checklist is intended to serve as a guide for applicants as to the elements that ordinarily need to be addressed in a complete Stormwater Report. The checklist is also intended to provide conservation commissions and other reviewing authorities with a summary of the components necessary for a comprehensive Stormwater Report that addresses the ten Stormwater Standards.

Note: Because stormwater requirements vary from project to project, it is possible that a complete Stormwater Report may not include information on some of the subjects specified in the Checklist. If it is determined that a specific item does not apply to the project under review, please note that the item is not applicable (N.A.) and provide the reasons for that determination.

A complete checklist must include the Certification set forth below signed by the Registered Professional Engineer who prepared the Stormwater Report.

Registered Professional Engineer's Certification

I have reviewed the Stormwater Report, including the soil evaluation, computations, Long-term Pollution Prevention Plan, the Construction Period Erosion and Sedimentation Control Plan (if included), the Long-term Post-Construction Operation and Maintenance Plan, the Illicit Discharge Compliance Statement (if included) and the plans showing the stormwater management system, and have determined that they have been prepared in accordance with the requirements of the Stormwater Management Standards as further elaborated by the Massachusetts Stormwater Handbook. I have also determined that the information presented in the Stormwater Checklist is accurate and that the information presented in the Stormwater Report accurately reflects conditions at the site as of the date of this permit application.

Registered Professional Engineer Block and Signature

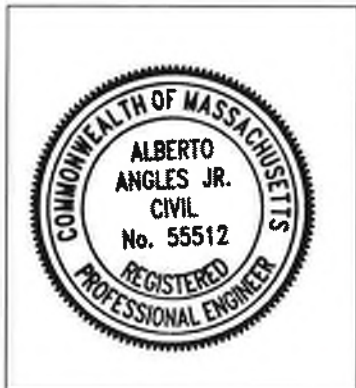

Alberto Angles Jr. 6/23/20
Signature and Date

Checklist

Project Type: Is the application for new development, redevelopment, or a mix of new and redevelopment?

- New development
- Redevelopment
- Mix of New Development and Redevelopment



Checklist for Stormwater Report

Checklist (continued)

LID Measures: Stormwater Standards require LID measures to be considered. Document what environmentally sensitive design and LID Techniques were considered during the planning and design of the project:

- No disturbance to any Wetland Resource Areas
- Site Design Practices (e.g. clustered development, reduced frontage setbacks)
- Reduced Impervious Area (Redevelopment Only)
- Minimizing disturbance to existing trees and shrubs
- LID Site Design Credit Requested:
 - Credit 1
 - Credit 2
 - Credit 3
- Use of "country drainage" versus curb and gutter conveyance and pipe
- Bioretention Cells (includes Rain Gardens)
- Constructed Stormwater Wetlands (includes Gravel Wetlands designs)
- Treebox Filter
- Water Quality Swale
- Grass Channel
- Green Roof
- Other (describe): _____

Standard 1: No New Untreated Discharges

- No new untreated discharges
- Outlets have been designed so there is no erosion or scour to wetlands and waters of the Commonwealth
- Supporting calculations specified in Volume 3 of the Massachusetts Stormwater Handbook included.



Checklist for Stormwater Report

Checklist (continued)

Standard 2: Peak Rate Attenuation

- Standard 2 waiver requested because the project is located in land subject to coastal storm flowage and stormwater discharge is to a wetland subject to coastal flooding.
- Evaluation provided to determine whether off-site flooding increases during the 100-year 24-hour storm.
- Calculations provided to show that post-development peak discharge rates do not exceed pre-development rates for the 2-year and 10-year 24-hour storms. If evaluation shows that off-site flooding increases during the 100-year 24-hour storm, calculations are also provided to show that post-development peak discharge rates do not exceed pre-development rates for the 100-year 24-hour storm.

Standard 3: Recharge

- Soil Analysis provided.
- Required Recharge Volume calculation provided.
- Required Recharge volume reduced through use of the LID site Design Credits.
- Sizing the infiltration, BMPs is based on the following method: Check the method used.
 - Static
 - Simple Dynamic
 - Dynamic Field¹
- Runoff from all impervious areas at the site discharging to the infiltration BMP.
- Runoff from all impervious areas at the site is *not* discharging to the infiltration BMP and calculations are provided showing that the drainage area contributing runoff to the infiltration BMPs is sufficient to generate the required recharge volume.
- Recharge BMPs have been sized to infiltrate the Required Recharge Volume.
- Recharge BMPs have been sized to infiltrate the Required Recharge Volume *only* to the maximum extent practicable for the following reason:
 - Site is comprised solely of C and D soils and/or bedrock at the land surface
 - M.G.L. c. 21E sites pursuant to 310 CMR 40.0000
 - Solid Waste Landfill pursuant to 310 CMR 19.000
 - Project is otherwise subject to Stormwater Management Standards only to the maximum extent practicable.
- Calculations showing that the infiltration BMPs will drain in 72 hours are provided.
- Property includes a M.G.L. c. 21E site or a solid waste landfill and a mounding analysis is included.

¹ 80% TSS removal is required prior to discharge to infiltration BMP if Dynamic Field method is used.



Checklist for Stormwater Report

Checklist (continued)

Standard 3: Recharge (continued)

- The infiltration BMP is used to attenuate peak flows during storms greater than or equal to the 10-year 24-hour storm and separation to seasonal high groundwater is less than 4 feet and a mounding analysis is provided.
- Documentation is provided showing that infiltration BMPs do not adversely impact nearby wetland resource areas.

Standard 4: Water Quality

The Long-Term Pollution Prevention Plan typically includes the following:

- Good housekeeping practices;
 - Provisions for storing materials and waste products inside or under cover;
 - Vehicle washing controls;
 - Requirements for routine inspections and maintenance of stormwater BMPs;
 - Spill prevention and response plans;
 - Provisions for maintenance of lawns, gardens, and other landscaped areas;
 - Requirements for storage and use of fertilizers, herbicides, and pesticides;
 - Pet waste management provisions;
 - Provisions for operation and management of septic systems;
 - Provisions for solid waste management;
 - Snow disposal and plowing plans relative to Wetland Resource Areas;
 - Winter Road Salt and/or Sand Use and Storage restrictions;
 - Street sweeping schedules;
 - Provisions for prevention of illicit discharges to the stormwater management system;
 - Documentation that Stormwater BMPs are designed to provide for shutdown and containment in the event of a spill or discharges to or near critical areas or from LUHPPL;
 - Training for staff or personnel involved with implementing Long-Term Pollution Prevention Plan;
 - List of Emergency contacts for implementing Long-Term Pollution Prevention Plan.
- A Long-Term Pollution Prevention Plan is attached to Stormwater Report and is included as an attachment to the Wetlands Notice of Intent.
 - Treatment BMPs subject to the 44% TSS removal pretreatment requirement and the one inch rule for calculating the water quality volume are included, and discharge:
 - is within the Zone II or Interim Wellhead Protection Area
 - is near or to other critical areas
 - is within soils with a rapid infiltration rate (greater than 2.4 inches per hour)
 - involves runoff from land uses with higher potential pollutant loads.
 - The Required Water Quality Volume is reduced through use of the LID site Design Credits.
 - Calculations documenting that the treatment train meets the 80% TSS removal requirement and, if applicable, the 44% TSS removal pretreatment requirement, are provided.



Checklist for Stormwater Report

Checklist (continued)

Standard 4: Water Quality (continued)

- The BMP is sized (and calculations provided) based on:
 - The ½" or 1" Water Quality Volume or
 - The equivalent flow rate associated with the Water Quality Volume and documentation is provided showing that the BMP treats the required water quality volume.
- The applicant proposes to use proprietary BMPs, and documentation supporting use of proprietary BMP and proposed TSS removal rate is provided. This documentation may be in the form of the propriety BMP checklist found in Volume 2, Chapter 4 of the Massachusetts Stormwater Handbook and submitting copies of the TARP Report, STEP Report, and/or other third party studies verifying performance of the proprietary BMPs.
- A TMDL exists that indicates a need to reduce pollutants other than TSS and documentation showing that the BMPs selected are consistent with the TMDL is provided.

Standard 5: Land Uses With Higher Potential Pollutant Loads (LUHPPLs)

- The NPDES Multi-Sector General Permit covers the land use and the Stormwater Pollution Prevention Plan (SWPPP) has been included with the Stormwater Report.
- The NPDES Multi-Sector General Permit covers the land use and the SWPPP will be submitted **prior to** the discharge of stormwater to the post-construction stormwater BMPs.
- The NPDES Multi-Sector General Permit does **not** cover the land use.
- LUHPPLs are located at the site and industry specific source control and pollution prevention measures have been proposed to reduce or eliminate the exposure of LUHPPLs to rain, snow, snow melt and runoff, and been included in the long term Pollution Prevention Plan.
- All exposure has been eliminated.
- All exposure has **not** been eliminated and all BMPs selected are on MassDEP LUHPPL list.
- The LUHPPL has the potential to generate runoff with moderate to higher concentrations of oil and grease (e.g. all parking lots with >1000 vehicle trips per day) and the treatment train includes an oil grit separator, a filtering bioretention area, a sand filter or equivalent.

Standard 6: Critical Areas

- The discharge is near or to a critical area and the treatment train includes only BMPs that MassDEP has approved for stormwater discharges to or near that particular class of critical area.
- Critical areas and BMPs are identified in the Stormwater Report.



Checklist for Stormwater Report

Checklist (continued)

Standard 7: Redevelopments and Other Projects Subject to the Standards only to the maximum extent practicable

- The project is subject to the Stormwater Management Standards only to the maximum Extent Practicable as a:
 - Limited Project
 - Small Residential Projects: 5-9 single family houses or 5-9 units in a multi-family development provided there is no discharge that may potentially affect a critical area.
 - Small Residential Projects: 2-4 single family houses or 2-4 units in a multi-family development with a discharge to a critical area
 - Marina and/or boatyard provided the hull painting, service and maintenance areas are protected from exposure to rain, snow, snow melt and runoff
 - Bike Path and/or Foot Path
 - Redevelopment Project
 - Redevelopment portion of mix of new and redevelopment.
- Certain standards are not fully met (Standard No. 1, 8, 9, and 10 must always be fully met) and an explanation of why these standards are not met is contained in the Stormwater Report.
- The project involves redevelopment and a description of all measures that have been taken to improve existing conditions is provided in the Stormwater Report. The redevelopment checklist found in Volume 2 Chapter 3 of the Massachusetts Stormwater Handbook may be used to document that the proposed stormwater management system (a) complies with Standards 2, 3 and the pretreatment and structural BMP requirements of Standards 4-6 to the maximum extent practicable and (b) improves existing conditions.

Standard 8: Construction Period Pollution Prevention and Erosion and Sedimentation Control

A Construction Period Pollution Prevention and Erosion and Sedimentation Control Plan must include the following information:

- Narrative;
 - Construction Period Operation and Maintenance Plan;
 - Names of Persons or Entity Responsible for Plan Compliance;
 - Construction Period Pollution Prevention Measures;
 - Erosion and Sedimentation Control Plan Drawings;
 - Detail drawings and specifications for erosion control BMPs, including sizing calculations;
 - Vegetation Planning;
 - Site Development Plan;
 - Construction Sequencing Plan;
 - Sequencing of Erosion and Sedimentation Controls;
 - Operation and Maintenance of Erosion and Sedimentation Controls;
 - Inspection Schedule;
 - Maintenance Schedule;
 - Inspection and Maintenance Log Form.
- A Construction Period Pollution Prevention and Erosion and Sedimentation Control Plan containing the information set forth above has been included in the Stormwater Report.



Checklist for Stormwater Report

Checklist (continued)

Standard 8: Construction Period Pollution Prevention and Erosion and Sedimentation Control (continued)

- The project is highly complex and information is included in the Stormwater Report that explains why it is not possible to submit the Construction Period Pollution Prevention and Erosion and Sedimentation Control Plan with the application. A Construction Period Pollution Prevention and Erosion and Sedimentation Control has **not** been included in the Stormwater Report but will be submitted **before** land disturbance begins.
- The project is **not** covered by a NPDES Construction General Permit.
- The project is covered by a NPDES Construction General Permit and a copy of the SWPPP is in the Stormwater Report.
- The project is covered by a NPDES Construction General Permit but no SWPPP been submitted. The SWPPP will be submitted BEFORE land disturbance begins.

Standard 9: Operation and Maintenance Plan

- The Post Construction Operation and Maintenance Plan is included in the Stormwater Report and includes the following information:
 - Name of the stormwater management system owners;
 - Party responsible for operation and maintenance;
 - Schedule for implementation of routine and non-routine maintenance tasks;
 - Plan showing the location of all stormwater BMPs maintenance access areas;
 - Description and delineation of public safety features;
 - Estimated operation and maintenance budget; and
 - Operation and Maintenance Log Form.
- The responsible party is **not** the owner of the parcel where the BMP is located and the Stormwater Report includes the following submissions:
 - A copy of the legal instrument (deed, homeowner's association, utility trust or other legal entity) that establishes the terms of and legal responsibility for the operation and maintenance of the project site stormwater BMPs;
 - A plan and easement deed that allows site access for the legal entity to operate and maintain BMP functions.

Standard 10: Prohibition of Illicit Discharges

- The Long-Term Pollution Prevention Plan includes measures to prevent illicit discharges;
- An Illicit Discharge Compliance Statement is attached;
- NO Illicit Discharge Compliance Statement is attached but will be submitted **prior to** the discharge of any stormwater to post-construction BMPs.

**Deer Island Treatment Plant
Parking Lot Modifications
Boston, MA**

Stormwater Report

Prepared for:

**Massachusetts Water Resources Authority
Charlestown Navy Yard, 100 First Avenue
Boston, Massachusetts 02129**

Prepared by:

**Hazen and Sawyer
24 Federal Street, 5th Floor
Boston, MA 02110**

Project Description

The proposed project includes the reconfiguration of an existing parking lot to add 11 new parking spaces to an existing public parking lot servicing the Deer Island Public Access Area. An area of approximately 2,008 square feet will be converted to public parking spaces to improve public access. This includes the conversion of approximately 1,657 square feet of existing pervious surface, consisting of stone medians and landscaped areas, to impervious asphalt pavement; the remaining 351 square feet includes the relocation of 2 existing parking spaces and an existing asphalt walkway located southeast of the parking lot. The proposed Best Management Practice (BMP) consists of a leaching catch basin to capture stormwater runoff from the new parking spaces and allow runoff to infiltrate into the ground.

Existing Conditions

The proposed project is located northwest of the Deer Island Wastewater Treatment Plan in the City of Boston, Massachusetts. The parking lot area consists of asphalt pavement, concrete sidewalks, and stone/landscaped medians. The site generally slopes from north to south of the parking lot. Stormwater is collected by catch basins located on Tafts Avenue that convey stormwater to the street sewer network.

Regulatory Criteria

In accordance with the Wetlands Protection Act Regulations, 310 Code of Massachusetts Regulations (CMR) 10.05 (6)(k), construction and redevelopment in the Buffer Zone shall be managed according to the Massachusetts Stormwater Management Standards. The project area is located within 100 feet of coastal banks and dunes, and in accordance with the Wetlands Protection Act Regulations, 310 (CMR) 10.02 (2), an area within 100 feet of any coastal banks and dunes is defined as the Buffer Zone. Therefore, since a portion of the project is in the Buffer Zone, regulation 310 (CMR) 10.05 (6)(k) is applicable to this project. In addition, the Massachusetts Stormwater Handbook defines redevelopment projects as the following:

- Maintenance and improvement of existing roadways, including widening less than a single lane, adding shoulders, correcting substandard intersections, improving existing drainage systems, and repaving;
- Development, rehabilitation, expansion and phased projects on previously developed sites, provided the redevelopment results in no net increase in impervious area; and
- Remedial projects specifically designed to provide improved stormwater management, such as projects to separate storm drains and sanitary sewers and stormwater retrofit projects.

The proposed project will increase the impervious cover for the addition of the parking spaces, improve the existing pavement by repaving it, improve the existing drainage and would also create new pervious landscaped areas in existing impervious surfaces for the relocation of an existing sidewalk. Therefore, the project qualifies as a mix of new development and redevelopment since it is creating additional impervious cover alongside development rehabilitation on a previously developed site.

The following section describes how the proposed stormwater management design addresses each of the applicable standards. Since the project qualifies as a mix of new development and redevelopment, the project is required to meet the standards to the maximum extent practicable.

Standard 1: No new Stormwater conveyances may discharge untreated stormwater directly or cause erosion in wetlands or waters of the Commonwealth – Standard has been met

The proposed redevelopment will not create new stormwater conveyances. The new impervious areas would discharge to a leaching catch basin that would infiltrate runoff into the ground.

Standard 2: Stormwater management systems shall be designed so that post-development peak discharge rates do not exceed pre-development peak discharge rates – Standard is waived

A waiver of Standard 2 is requested because the project is located in a Land Subject to Coastal Storm Flowage.

Standard 3: Loss of annual recharge to groundwater should be eliminated or minimized through the use of infiltration measures – Standard has been met

The provided leaching catch basin meets the stormwater manual's guidelines by providing sufficient recharge volume for the project site due to the increase in impervious surfaces. The total area of new impervious surfaces is 0.04 acres. In accordance with the USDA NRCS soil report and borings close to the project site, the site's soil is composed of sand and gravel; geotechnical investigations would be performed to confirm the soil prior to the installation of the leaching catch basin. Assuming Type A soil and a 0.6-inch precipitation in accordance with Table 2.3.2 of the Stormwater Manual, the required recharge volume is 83 cubic feet (cf) for the new impervious areas. The leaching catch basin provides a total of 130 cf of storage, which exceeds the required recharge volume for the site. The recharge volume calculations are included in Appendix A.

Standard 4: Stormwater management systems shall be designed to remove 80% of the average annual post-construction load of Total Suspended Solids (TSS) – Standard has been met to the maximum extent practicable

The proposed leaching catch basin is expected to provide 80% TSS removal, meeting the removal requirement of Standard 4. The TSS removal worksheet is included in Appendix B. The leaching catch basin is also located downstream of the parking lot drainage area, and since it's sized to exceed the required recharge volume for the new impervious surface, it would provide groundwater recharge for a portion of the existing impervious surface. The leaching catch basin would also provide pretreatment since it is designed to be off-line and would be located within the stone median. No permanent structural BMPs are proposed to be constructed to treat water quality volume due to lack of space, majority of the parking lot area is covered by impervious surfaces (parking spaces and sidewalks); there is only a stone median in the middle of the parking lot but this area contains various underground utilities and above grade site features (anchor, bike rack and signs) that do not provide enough space for an additional BMP.

Standard 5: For land uses with higher potential pollutant loads, source control and pollution prevention shall be implemented to eliminate or reduce the discharge of stormwater runoff from such land uses to the maximum extent practicable – Standard does not apply

No land uses with higher potential pollutant loads exist in the project area.

Standard 6: Stormwater discharges to critical areas require the use of specific source control and pollution prevention measures and specific structural stormwater best management practices determined by the Department – Standard does not apply

There would not be stormwater discharge to critical areas in this project.

Standard 7: A redevelopment project is required to meet the following Stormwater Management Standards only to the maximum extent practicable: Standard 2, Standard 3, and the pretreatment and structural best management practice requirements of Standards 4, 5, and 6 - Standard has been met

The project has been designed to meet and conform to the standards to the maximum extent practicable.

Standard 8: A plan to control construction-related impacts including erosion, sedimentation and other pollutant sources during construction and land disturbance activities shall be developed and implemented – Standard has been met



Erosion and sediment controls are shown and documented on the Contract Drawings and Contract Specifications, and these are included in Appendix C.

Standard 9: A long-term operation and maintenance plan shall be developed and implemented to ensure that stormwater management systems function as designed – Standard has been met

An Operation and Maintenance Plan is included in Appendix D.

Standard 10: All illicit discharges to the stormwater management system are prohibited – Standard has been met

The project does not propose illicit discharges to the stormwater management system.

Appendix A

Groundwater Recharge Volume Calculations

H&S Project No.:

90364-004

Project:

Deer Island Parking Lot

Client:

MWRA

Location:

Deer Island, BOS

Performed by:

J. Rivas

Date: 05/05/2020

Checked by:

D. Sheeran

Date: 05/07/2020

Source:

Massachusetts Stormwater Handbook

Parking Lot Drainage Area	
New Impervious Area (sf)	1,657
Existing Impervious Area (sf)	6,940
Total (sf)	8,597

From USDA, Site is Soil Group A; (Table 2.3.2)

0.6 in of runoff

Per Standard 3, Required Volume to Recharge (Rv):

82.85 cf

NRCS HYDROLOGIC SOIL TYPE	APPROX. SOIL TEXTURE	TARGET DEPTH FACTOR (F)
A	sand	0.6-inch
B	loam	0.35-inch
C	silty loam	0.25-inch
D	clay	0.1-inch

Table 2.3.2: Recharge Target Depth by Hydrologic Soil Group

Vol 3 Chapt 1 - Massachusetts Stormwater Handbook

Storage Volume

Width of practice (ft) -D	4.00
Height of Ring (ft)	4.00
Volume of 1 Ring Practice (CF)	50.00
Storage Capacity of Ring (CF)	50.00

Depth of Open-Graded Stone Below Footing (ft)	2.00
Area of Stone Base Including Barrel (sf)	61.28
Area of Stone Base Only (Excluding Barrel) (sf)	42.96
Volume of Open-Graded Stone Base (CF)	294.41
Porosity of Open-Graded Stone Base (%)	28%
Storage Capacity Open-Graded Stone Base (CF)	82.60

Total Volume of Storage Provided (CF) **132.60** Meets Standard

$$Time_{drawdown} = \frac{Rv}{(K)(Bottom\ Area)}$$

K (table 2.3.3 - see below) = 8.27 in/hr
 Tdrawdown (hr)= 1.96 Ok - Less than 72 hrs

Table 2.3.3. 1982 Rawls Rates¹⁸

Texture Class	NRCS Hydrologic Soil Group (HSG)	Infiltration Rate Inches/Hour
Sand	A	8.27
Loamy Sand	A	2.41
Sandy Loam	B	1.02
Loam	B	0.52
Silt Loam	C	0.27
Sandy Clay Loam	C	0.17
Clay Loam	D	0.09
Silty Clay Loam	D	0.06
Sandy Clay	D	0.05
Silty Clay	D	0.04
Clay	D	0.02

Appendix B

TSS Removal Worksheet

INSTRUCTIONS:

1. In BMP Column, click on Blue Cell to Activate Drop Down Menu
2. Select BMP from Drop Down Menu
3. After BMP is selected, TSS Removal and other Columns are automatically completed.

Version 1, Automated: Mar. 4, 2008

Location:

TSS Removal Calculation Worksheet

B BMP ¹	C TSS Removal Rate ¹	D Starting TSS Load*	E Amount Removed (C*D)	F Remaining Load (D-E)
<input type="text" value="Leaching Catch Basin"/>	0.80	1.00	0.80	0.20
<input type="text"/>	0.00	0.20	0.00	0.20
<input type="text"/>	0.00	0.20	0.00	0.20
<input type="text"/>	0.00	0.20	0.00	0.20
<input type="text"/>	0.00	0.20	0.00	0.20

Total TSS Removal =

Separate Form Needs to be Completed for Each Outlet or BMP Train

Project:
 Prepared By:
 Date:

*Equals remaining load from previous BMP (E) which enters the BMP

Appendix C

Contract Drawings and Specifications

SECTION 01560

TEMPORARY ENVIRONMENTAL CONTROLS

PART 1 - GENERAL

1.01 REQUIREMENTS

A. Dust Control

1. The CONTRACTOR shall take all necessary measures to control dust and to prevent spillage of excavated materials.
2. The CONTRACTOR shall remove all spillage of excavated materials, debris or dust by methods approved by the AUTHORITY.
3. The CONTRACTOR shall sprinkle water at locations and in such quantities and at such frequencies as may be required by the AUTHORITY to control dust and prevent it from becoming a nuisance.
4. Dust control and cleaning measures shall be provided at no additional cost to the AUTHORITY.

B. Environmental Protection

1. Furnish all labor, materials and equipment and perform all work required for the prevention of environmental pollution in conformance with applicable laws and regulations, during and as the result of construction operations under this Contract. For the purpose of this Section, environmental pollution is defined as the presence of chemical, physical, or biological elements or agents which adversely affect human health or welfare; unfavorably alter ecological balances of importance to human life; affect other species of importance to man; or degrade the utility of the environment for aesthetic and/or recreational purposes.
2. Comply with all applicable Federal, State and local laws and regulations concerning environmental pollution control and abatement.

C. Notifications

1. The AUTHORITY will notify the CONTRACTOR in writing of any non-compliance with the foregoing provisions or of any environmentally objectionable acts and corrective action to be taken. State or local agencies responsible for verification of certain aspects of the environmental protection requirements shall notify the CONTRACTOR in writing directly or through the AUTHORITY, of any non-compliance with State or local requirements. After receipt of such notice from the AUTHORITY or from the regulatory agency through the AUTHORITY, immediately take corrective action. Such notice, when delivered to the CONTRACTOR, shall be deemed sufficient for the purpose. If the CONTRACTOR fails or refuses to comply promptly, the AUTHORITY may issue an order stopping all or part of the Work until

satisfactory corrective action has been taken. No part of the time lost due to any such stop orders shall be made the subject of a claim for extension of time or for excess costs or damages by the CONTRACTOR unless it is later determined that the CONTRACTOR was in compliance.

D. Implementation

1. Prior to commencement of the Work, meet with the AUTHORITY to develop mutual understandings relative to compliance with these provisions and administration of the environmental pollution control program.
2. Remove temporary environmental control features, when approved by the AUTHORITY and incorporate permanent control features into the Project at the earliest practicable time.

PART 2 – PRODUCTS

(NOT USED)

PART 3 – EXECUTION

(NOT USED)

- END OF SECTION -

01560-2

SECTION 02276

EROSION AND SEDIMENTATION CONTROL

PART 1 – GENERAL

1.01 SUMMARY OF WORK

- A. Control soil erosion resulting from construction operations, prevent flow of sediment from construction site, and contain construction materials within protected working area to prevent damage to any catch basin, stream, wetlands, and coastal resource area, including but not limited to, river, coastal bank, beach, or flood plain.

1.02 RELATED SECTIONS

- A. Section 01300 – Submittal

1.03 REFERENCE SPECIFICATIONS, CODES, AND STANDARDS

- A. Without limiting the generality of the other requirements of the Specifications, all work herein shall conform to the applicable requirements of the following documents. All referenced Specifications, codes, and standards refer to the most current issue available at the time of Bid Opening.

- 1. American Society for Testing and Materials (ASTM):

- i. ASTM D 3776 - Standard Test Methods for Mass per Unit Area (Weight) of Fabric
- ii. ASTM D 3786 - Standard Test Method for Bursting Strength of Textile Fabrics – Diaphragm Bursting Tester Method
- iii. ASTM D 4355 - Standard Test Method for Deterioration of Geotextiles by Exposure to Light, Moisture and Heat in a Xenon Arc Type Apparatus
- iv. ASTM D 4491 - Standard Test Methods for Water Permeability of Geotextiles by Permittivity
- v. ASTM D 4632 - Standard Test Method for Grab Breaking Load and Elongation of Geotextiles
- vi. ASTM D 4751 - Standard test Method for Determining Opening Size of a Geotextile
- vii. ASTM D 4833 - Standard Test Method for Index Puncture Resistance of Geomembranes and related Products

1.04 SUBMITTALS

- A. Shop Drawings: Submit the following in accordance with Section 01300 - Submittals:

1. Inlet Protection
2. Straw Wattles; and
3. Geotextile Silt Fence;

1.05 QUALITY ASSURANCE

- A. Operations restricted to areas of work indicated on Drawings and area which must be entered for construction of temporary or permanent facilities.
- B. If construction materials are washed away during construction, remove materials from fouled areas.
- C. Limit surface area of erodible earth material exposed by clearing and grubbing, excavation, borrow and fill operations and to direct immediate permanent or temporary pollution control measures to prevent contamination of any stream or wetlands, including construction of temporary berms, dikes, dams, sediment basins, sediment traps, slope drains, and use of portable filtration system, temporary mulches, mats, or other control devices or methods as necessary to control erosion.
- D. Prior to initiating construction, CONTRACTOR to visually inspect and clean all catch basins adjacent to work areas. Any basins containing silt and debris shall be noted by the CONTRACTOR prior to construction. A written notice shall be provided to the AUTHORITY listing location of filled basins.

PART 2 – PRODUCTS

2.01 INLET EROSION CONTROL MEASURES

- A. Inlet Protection Measures shall be constructed at the locations indicated on the Drawings or as directed by the AUTHORITY.
- B. Materials for Inlet Erosion Control Measures consist of catch basin inserts.
 1. Inlet Erosion Control Measures shall be designed, installed and maintained in accordance with the Massachusetts Erosion and Sediment Control Guidelines for Urban and Suburban Areas. Measures not described in the Massachusetts Erosion and Sediment Control Guidelines for Urban and Suburban Areas shall be designed, installed, and maintained in accordance with the AUTHORITY'S and Manufacturer's instructions, with more stringent instructions superseding. The cost of inlet erosion control measures shall include all excavation, grading and materials as well as all maintenance activities required.
- C. Inlet Protection:
 1. Inlet Protection (Catch Basin inserts) shall only be utilized in areas where the use of the storm drain inlet protection can create adverse or hazardous driving conditions to the work site or roadways as determined and directed by the AUTHORITY.

2. An inlet protection insert is a woven polypropylene bag that is inserted into a catch basin or drop inlet to capture sediment. Sediment control devices are equipped with lifting loops or lugs to allow the devices to be removed, cleaned and reinserted back into catch basin or drop inlet.
3. The sediment control device shall be manufactured from woven polypropylene and sewn using high strength nylon thread.
4. The sediment control device should be sized to fit a standard catch basin or drop inlet.
5. The sediment control device should include dumping straps and a visual means to indicate when the device needs to be emptied.
6. The fabric shall be woven polypropylene fabric with the following properties:

<u>Property</u>	<u>Test Method</u>	<u>Test Result</u>
Grab Tensile	ASTM D-4632	265 lbs to 300 lbs.
Grab Elongation	ASTM D-4632	20%
Puncture	ASTM D-4833	120 lbs.
Min. Mullen Burst	ASTM D-3786	420 lbs
Min. Trapezoid Tear	ASTM D-4533	120 lbs.
Min. UV Resistance	ASTM D-4355	80%
Apparent Opening	ASTM D-4751	20 to 40 US Sieve
Min. Flow Rate	ASTM D-4491	40 Gal/Min/Ft ²
Permittivity	ASTM D-4491	0.55 sec. ⁻¹

2.02 STRAW WATTLES

- A. Wattles shall be a straw-filled tube of flexible netting material, machine-produced tube of compacted rice straw that is Certified Weed Free Forage, by a Manufacturer whose principle business is wattle manufacturing. The netting shall consist of seamless, high-density polyethylene and ethyl vinyl acetate and contain ultra violet inhibitors.
- B. Light weight rolled erosion control straw or wood fiber blankets (RECB) rolled up to create a wattle type device shall not be used.
- C. The Wattle shall meet the minimum performance requirements of Table 1. The product shall meet all numeric performance values in Table 1 under the specific conditions as stated.

TABLE 1— WATTLE PROPERTIES

Property	Test Method	Units	Min. Value
Mass per Unit Weight	Field Measured	(lbs/ft)	1.6

Property	Test Method	Units	Min. Value
Dimension	Field Measured	(Dia/Inches)	12
Net Strand Thickness	Field Measured	(Inches)	0.030
Net Knot Thickness	Field Measured	(Inches)	0.055
Netting Unit Weight	Certified	(Ounces/ft)	0.35
Sediment Retention Capacity	Rainfall Sim.	(lbs/ft)	30
Installed Free-Board Ht.	Field Measured	(Height/Inches)	6.0 — 7.0
Straw Fiber	Field Measured	Avg. Length (in)	3.0
Soil Loss'	Rainfall Sim.	% Effectiveness	58
De-Stabilizing Moisture	Rainfall Sim.	% Retained (Max.)	11
Fiber Content	Certified	% Rice Straw	100

D. Straw wattles shall be manufactured by:

1. The Wattle Guys;
2. Valencia Pipe Company, Inc.;
3. California Straw Works;
4. Or equal.

E. Straw wattles shall be utilized for additional lining of the silt fence, around material stockpiles, and/or around catch basins.

2.03 STEEL POSTS

A. 1-inch by 1- inch by 3-feet.

2.04 WOOD STAKES

A. 1-inch by 1-inch by 3-feet, unless otherwise specified in these Specifications or as indicated on the Drawings.

2.05 GEOTEXTILE SILT FENCE

A. Wood posts shall be a minimum of 3-feet in length, 2-inches by 2-inches.

B. Silt fence fabric shall be a woven, polypropylene, ultraviolet resistant material.

1. Silt fence fabric to be fastened securely to weld wire fence with ties spaced every 12-inches at the top and mid-section. The fabric shall be no more than 18-inches above grade.

02276-4

2. When two sections of fabric adjoin each other, they shall be overlapped by six-inches and folded.
3. Maintenance shall be performed regularly, and material removed when budes or holes develop in the fence fabric.
4. The maximum drainage area for overland flow to a silt fence shall not exceed ½ acre per 100 feet of fence.
5. Prefabricated commercial silt fence may be substituted for built-in-field fence.
6. Silt fences shall be manufactured by:
 - i. TenCate Geosynthetics America;
 - ii. Propex Operating Company, LLC.;
 - iii. SKAPS Industries;
 - iv. Or equal.

PART 3 – EXECUTION

3.01 INSTALLATION

- A. Install sedimentation barriers in all locations as indicated on the Drawings.
- B. The CONTRACTOR shall inspect sedimentation barriers on a weekly basis and after each rainfall event that produces ¼-inches or more of rain. The CONTRACTOR shall submit logs documenting these checks on a weekly basis to the AUTHORITY.
 1. The CONTRACTOR shall also include an example photo of before and after work for repair and/or replacement of erosion controls.
- C. Prevent damage to vegetation adjacent to or outside of construction area limits.
- D. Do not dispose of any material, including debris, paints, chemicals, asphalt products, concrete curing compounds, fuels, lubricants, insecticides, wash water from concrete trucks or hydroseeders, or any other pollutant in streams, wet-lands, surface waters, or natural or man-made channels leading thereto, or unspecified locations.
- E. Clean and dispose of debris from sedimentation barriers on a weekly basis. Sediment removed shall be disposed of at a properly permitted facility.
- F. Upon completion of work on site, remove and dispose of sedimentation barriers and return area to original or better condition at no additional cost to the AUTHORITY.

3.02 PROTECTION OF STREAMS, WETLANDS, SURFACE WATER AND COASTAL RESOURCE AREAS

- A. Care shall be taken to prevent or reduce to a minimum any damage to any stream, drainage ditch, storm drain, sewer or coastal resource area from pollution by debris, sediment, or other material, or from the manipulation of equipment and/or materials in or near such streams. Water that has been used for washing or processing, or that contains oils or sediments that will reduce the quality of the water in the stream, shall not be directly returned to the stream or ocean. Such water shall be diverted through a settling basin or filter before being directed into the streams or ocean. Water containing oils shall be directed through an oil/water separator prior to discharge.
- B. All preventative measures shall be taken to avoid spillage of petroleum products and other pollutants. In the event of any spillage, prompt remedial action shall be taken in accordance with a contingency action drawing or plan approved by the Massachusetts Department of Environmental Protection.
- C. All erosion controls shall stay in place until the AUTHORITY'S environmental compliance staff has granted approval for removal.

3.03 STREET CLEANING

- A. Provide for daily street cleaning to remove any sediment that may have been tracked out at the end of each days work. Sediment should be removed by shoveling or sweeping and carefully removed to a suitable disposal area where it will not be re-eroded. Use of water to clean street shall not be allowed.

- END OF SECTION -

MASSACHUSETTS WATER RESOURCES AUTHORITY

DEER ISLAND TREATMENT PLANT

PARKING LOT MODIFICATIONS
BOSTON, MA

MWRA CONTRACT NO. 7645

MAY 2020



100% SUBMISSION

Hazen

HAZEN AND SAWYER
24 FEDERAL STREET, 5TH FLOOR
BOSTON, MASSACHUSETTS 02110

FOR PERMITTING USE ONLY - NOT FOR CONSTRUCTION

PROJECT NO.	_____
CONTRACT NO.	7645
CAD FILE NO.	7645_T04_G-001
SHEET NO.	7645_T04_G-001

INDEX OF DRAWINGS

SHEET NO. TITLE

- GENERAL**
 7645_TO4_G-001 COVER SHEET
 7645_TO4_G-002 LOCATION PLAN AND INDEX OF DRAWINGS

- CIVIL**
 7645_TO4_C-001 CIVIL LEGEND, ABBREVIATIONS AND NOTES
 7645_TO4_C-002 EXISTING CONDITIONS, DEMOLITION AND EROSION AND SEDIMENT CONTROL PLAN
 7645_TO4_C-003 PARKING AREA SITE LAYOUT
 7645_TO4_C-004 STORMWATER INFILTRATION SYSTEM AND GRADING PLAN
 7645_TO4_C-005 FINAL SITE PLAN
 7645_TO4_C-006 STANDARD DETAILS I
 7645_TO4_C-007 STANDARD DETAILS II

- ELECTRICAL**
 7645_TO4_E-001 ELECTRICAL LEGEND, ABBREVIATIONS, NOTES, AND DETAILS
 7645_TO4_E-002 ELECTRICAL DEMOLITION
 7645_TO4_E-003 ELECTRICAL NEW WORK

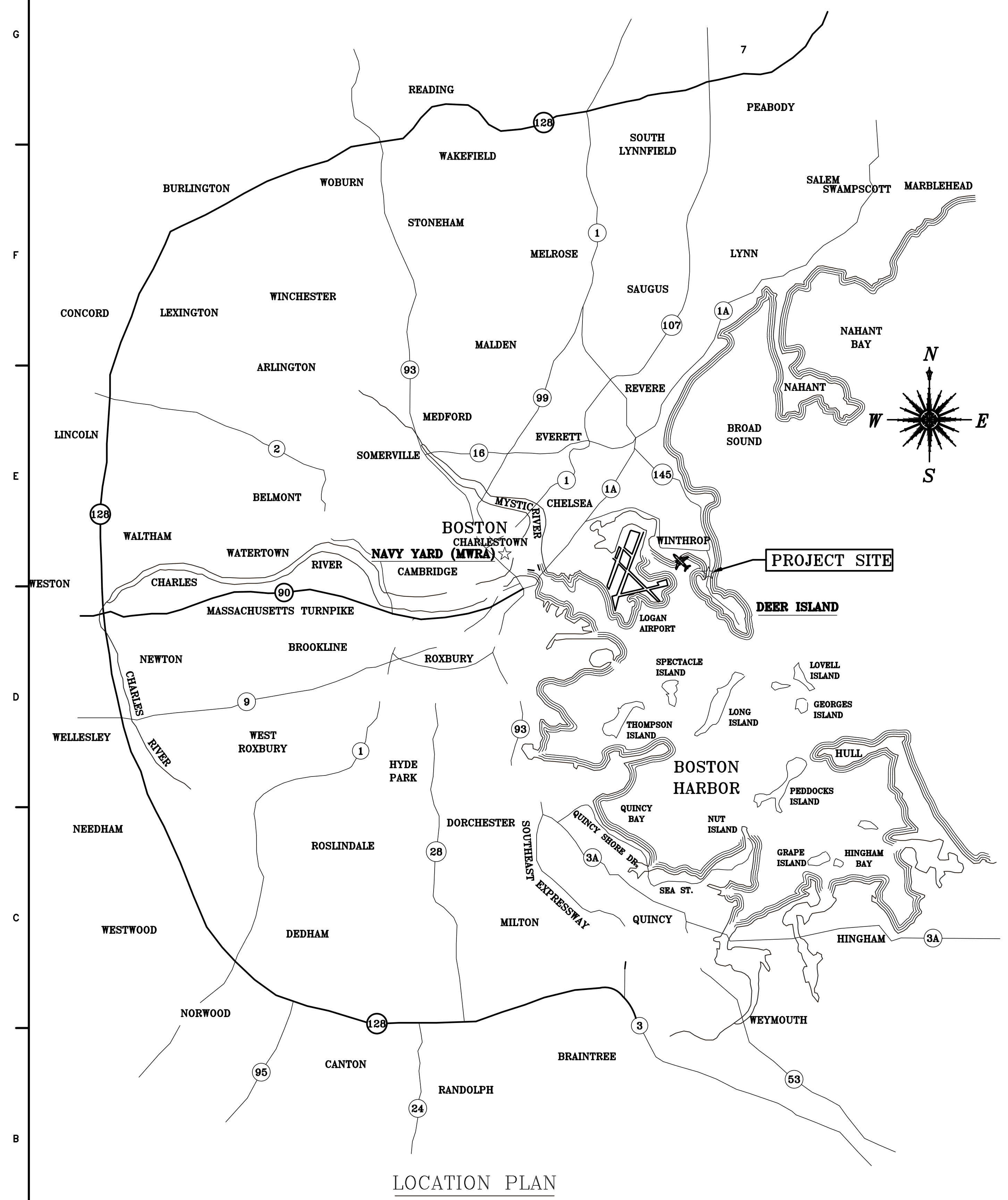
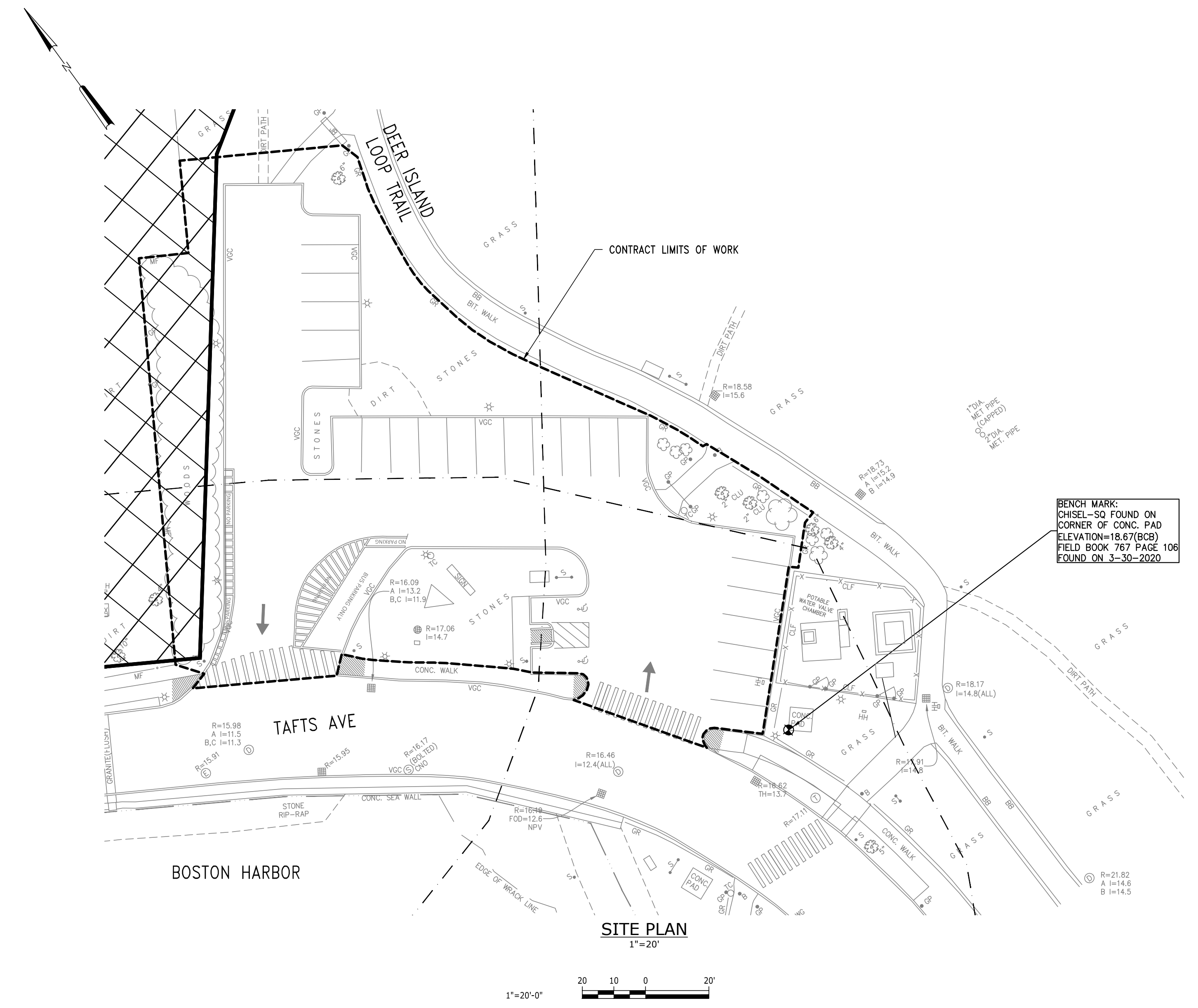

LOCATION PLAN

SCALE IN MILES
 1" = 1 MILE



Hazen
 HAZEN AND SAWYER
 24 FEDERAL STREET, 5TH FLOOR
 BOSTON, MASSACHUSETTS 02110

SCALE: AS SHOWN	DESIGNED BY: KTR	DATE	MADE BY	CHECKED BY	DESCRIPTION
DRAWN BY: KTR	CHECKED BY: AA	DATE	MADE BY	CHECKED BY	DESCRIPTION
APPROVED BY: AA		DATE	MADE BY	CHECKED BY	DESCRIPTION

MASSACHUSETTS WATER RESOURCES AUTHORITY
 DEER ISLAND TREATMENT PLANT
PARKING LOT MODIFICATIONS
 LOCATION PLAN AND
 INDEX OF DRAWINGS

PROJECT NO. _____
 CONTRACT NO. 7645
 CAD FILE NO. 7645_TO4_G-002
 SHEET NO. 7645_TO4_G-002

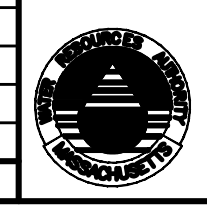

CIVIL ABBREVIATIONS

ADDL	ADDITIONAL	IRR	IRRIGATION PIPE
ADJ	ADJUSTABLE	L	LENGTH/ANGLE
AGGR	AGGREGATE	LP	LIGHT POLE
AL	ALUMINUM	LF	LINEAR FEET
ALLOW	ALLOWANCE/ALLOWABLE		
ALT	ALTERNATE	MAINT	MAINTENANCE
APPROX	APPROXIMATE	MNS	MAG NAIL SET
ARCH	ARCHITECTURAL	MH	MANHOLE
ASPH	ASPHALT	MAX	MAXIMUM
		MECH	MECHANICAL
BY	BALL VALVE	MJ	MECHANICAL JOINT
BFE	BASE FLOOD ELEVATION	MDC	METROPOLITAN DISTRICT COMMISSION
BM	BENCHMARK	MIN	MINIMUM
BIT.	BITUMINOUS	MISC.	MISCELLANEOUS
BLK	BLOCK	MON	MONUMENT
BD	BOARD		
BT	BOLT	N	NORTH
B	BORING	N/A	NOT APPLICABLE
BCB	BOSTON CITY BASE	NIS	NOT TO SCALE
BC	BOTTOM OF CURB	NO.	NUMBER
BOT	BOTTOM		
BW	BOTTOM WALL ELEVATION	O.C.	ON CENTER
BLDG	BUILDING	OD	OUTSIDE DIAMETER
BL	BUILDING LINE	OF	OVERFLOW
BFV	BUTTERFLY VALVE	OHE	OVERHEAD ELECTRIC
BYP	BYPASS		
		PAR	PARALLEL
CCB	CAPE COD BERM	PVMT	PAVEMENT
C.I.	CAST IRON PIPE	PE	POLYETHYLENE/PLAIN END
CB	CATCH BASIN	PVC	POLYVINYL CHLORIDE
CEM	CEMENT	P	PROPERTY LINE
CE	CENTERLINE	PS	PUMP STATION
C/C	CENTER TO CENTER		
CLF	CHAIN LINK FENCE	QTY	QUANTITY
CLR	CLEAR		
COMB	COMBINATION	RW	RAW WATER
CONC.	CONCRETE	REF	REFERENCE
CONST	CONSTRUCTION	RC	REINFORCED CONCRETE
CONT	CONSTRUCTION EASEMENT	RCP	REINFORCED CONCRETE PIPE
CONTR	CONTRACTOR	RET.	RETAINING WALL
CF	CUBIC FEET	REQD	REQUIRED
CFS	CUBIC FEET PER SECOND	REST	RESTRAINED
CY	CUBIC YARD	RJ	RESTRAINED JOINT
		RI	RIGHT
		ROW	RIGHT OF WAY
DET	DETAIL	SAN	SANITARY
DW	DEWATERING	SS	SANITARY SEWER
DIA	DIAMETER	SCH	SCHEDULE
DBH	DIAMETER AT BREAST HEIGHT	SECT	SECTION
DIM	DIMENSION	SERV	SERVICE
D	DRAIN	SEW	SEWER
DMH	DRAIN MANHOLE	SMH	SEWER MANHOLE
DWG	DRAWING	SHT	SHEET
DH	DRILL HOLE	SYL	SINGLE WHITE LINE
DYL	DOUBLE YELLOW LINE	SGC	SLOPED GRANITE CURB
DICL	DUCTILE IRON CEMENT LINED	SPEC	SPECIFICATION
DIP	DUCTILE IRON PIPE	SST	STAINLESS STEEL
		STD	STANDARD
E	EAST/EASEMENT	STA.	STATION
EA	EACH	ST	STREET
EFF	EFFLUENT	SD	STORM DRAINAGE
ELEC	ELECTRIC/ELECTRICAL	SD	STORM/SITE DRAIN
EB	ELECTRIC BARRIER	S	SOUTH/SLOPE
EMH	ELECTRIC MANHOLE	SQ	SQUARE
EL/ELEV.	ELEVATION	SF	SQUARE FEET
EOG	EDGE OF GRAVEL	SI	SQUARE INCH
EOP	EDGE OF PAVEMENT	SBL	SURVEY BASELINE
ENGR	ENGINEER		
ENT	ENTRANCE	TEL	TELEPHONE
EQ	EQUAL	TEMP	TEMPERATURE
EQPT	EQUIPMENT	TOC	TOP CURB
EXC	EXCAVATE		
EXIST.	EXISTING	TC	TOP OF CURB
EXT	EXTERIOR	TS	TRAFFIC SIGNAL MAST ARM/SPAN
		TYP.	TYPICAL
FT	FEET		
FL	FLANGE	UGE	UNDERGROUND ELECTRIC
FIN	FINISH	UST	UNDERGROUND STORAGE TANK
FFE	FINISH FLOOR ELEVATION	UTIL	UTILITY
FP	FIRE PROTECTION		
FTG	FOOTING/FITTING	V	VENT
FM	FORCE MAIN	VERT	VERTICAL
FDN	FOUNDATION	WG	WATER GATE
		WP	WATERPROOF
G	GAS/GAS LINE	WV	WATER VALVE
GV	GATE VALVE	W	WEST/WIDTH
		WCR	WHEEL CHAIR RAMP
HDWL	HEADWALL	W	WITH
H	HEIGHT	W/O	WITHOUT
HP	HIGH POINT		
HORIZ	HORIZONTAL	YD	YARD
HYD	HYDRANT	YI	YARD INLET
		YR	YEAR
IN	INCH		
INF	INFLUENT		
INV	INVERT ELEVATION		

CIVIL LEGEND

PROPOSED	EXISTING	DESCRIPTION
		CATCH BASIN
		DRAIN MANHOLE
		SEWER MANHOLE
		WATER MANHOLE
		GAS GATE
		WATER GATE
		FIRE HYDRANT
		UTILITY POLE
		LIGHT POLE
		HAND HOLE
		ELECTRIC BOX
		BOLLARD
		BUSH/SHRUB
		TREE WITH TRUNK DIAMETER
		CHAIN LINK FENCE
		WROUGHT IRON FENCE
		VERTICAL GRANITE CURB
		UNDERGROUND DRAIN LINE
		UNDERGROUND ELECTRIC LINE
		UNDERGROUND GAS LINE
		UNDERGROUND WATER LINE
		OVERHEAD WIRES
		MONITORING WELL
		BENCHMARK/CONTROL POINT
		MAJOR CONTOUR
		MINOR CONTOUR
		RIM ELEVATION
		TREE LINE
		TRANSFORMER
		PEDESTRIAN SIGNAL
		TRAFFIC POLE
		SIGN
		APPROX. PROPERTY LINE
		SUBGRADE
		INLET PROTECTION
		SILT FENCE
		LIMITS OF DEMOLITION
		TREE PROTECTION FENCE
		LIMITS OF COASTAL BANK
		LIMITS OF COASTAL DUNE
		100-FT WETLAND BUFFER
		FEMA FLOOD LINE
		BFE = 19.46 BCB = 13 NAVD88
		BFE = 18.46 BCB = 12 NAVD88
		MEAN HIGH WATER
		PAVEMENT PAINT (COLOR INDICATED)
		MILLED AND OVERLAID PAVEMENT
		BITUMINOUS CONCRETE SIDEWALK
		LANDSCAPING
		STONE
		PARKING STALL COUNT
		GATE
		SPOT ELEVATION
		CURB SPOT ELEVATION
		CONTRACT LIMITS OF WORK
		CONSTRUCTION ZONE FENCE
		LEACHING CATCH BASIN
		CONCRETE APRON
		CURB CUT

CIVIL NOTES:

- HORIZONTAL INFORMATION BASED ON MASSACHUSETTS STATE PLANE COORDINATE SYSTEM (NAD1983). VERTICAL INFORMATION BASED ON BOSTON CITY BASE COORDINATE SYSTEM (BCB).
- EXISTING GROUND ELEVATIONS AND LOCATIONS OF SURFACE FEATURES SHOWN ON THESE PLANS ARE BASED ON FIELD SURVEY PERFORMED BY NITSCH ENGINEERING ON APRIL 1, 2020.
- ALL UNDERGROUND UTILITIES AS SHOWN WERE COMPILED USING FIELD SURVEY INFORMATION AND AVAILABLE RECORD INFORMATION PROVIDED BY THE AUTHORITY.
- THE ACCURACY AND COMPLETENESS OF UNDERGROUND UTILITIES AS SHOWN ON THE PLANS ARE NOT GUARANTEED. THE CONTRACTOR SHALL BE RESPONSIBLE TO DETERMINE EXACT LOCATION, SIZE, TYPE, ETC. OF ALL UNDERGROUND UTILITIES WHETHER OR NOT THEY ARE SHOWN ON THE PLANS, BEFORE ANY CONSTRUCTION COMMENCES. THE CONTRACTOR SHALL TAKE THE NECESSARY PRECAUTIONS TO PROTECT ALL UTILITIES ENCOUNTERED.
- CONTRACTOR SHALL NOTIFY DIG SAFE 72 HOURS PRIOR TO CONSTRUCTION.
- EXISTING SERVICE CONNECTIONS FOR WATER, GAS, SEWER, ELECTRICITY, TELEPHONE AND CABLE TV ARE NOT SHOWN. CONTRACTOR SHALL VERIFY ALL SERVICES AS CONSTRUCTION PROCEEDS AND MAKE NECESSARY ADJUSTMENTS INCLUDING REPLACEMENT OR RELOCATION OF SERVICES. CONTRACTOR SHALL TAKE NECESSARY PRECAUTIONS TO PROTECT ALL SERVICES DURING CONSTRUCTION ACTIVITY WITHIN THE WORK AREA AT NO ADDITIONAL COST TO THE OWNER.
- THE CONTRACTOR SHALL RESTORE ALL PAVEMENT MARKINGS, PAVEMENT, SIDEWALK, CURBING, UTILITIES, FENCES, WALLS, PLANTINGS, OTHER INFRASTRUCTURE AND APPURTENANCES DISTURBED BY CONSTRUCTION ACTIVITIES TO THEIR ORIGINAL EXISTING CONDITION. AREAS AND UTILITIES OUTSIDE THE CONSTRUCTION DISTURBED BY THE CONTRACTOR SHALL BE RESTORED AT NO ADDITIONAL COST TO THE OWNER.
- WORK HOUR RESTRICTIONS SHALL BE IN ACCORDANCE WITH THE CITY OF BOSTON PUBLIC WORKS DEPARTMENT.
- ALL CATCH BASINS WITHIN AND TRIBUTARY TO THE LIMITS OF WORK SHALL BE PROTECTED FROM SEDIMENTS WITH INLET PROTECTION.
- CONTRACTOR IS RESPONSIBLE FOR THE ACQUISITION OF ALL PERMITS AS DEEMED NECESSARY BY THE CITY OF BOSTON AT NO ADDITIONAL COST TO THE AUTHORITY.
- STAGING AREAS DESIRED BY THE CONTRACTOR SHALL BE THE CONTRACTOR'S RESPONSIBILITY. THE CONTRACTOR SHALL COORDINATE ONSITE STAGING WITH THE AUTHORITY IF DESIRED AND IT SHALL BE PROVIDED AT NO ADDITIONAL COST TO THE AUTHORITY.
- ADDITIONAL BURIED UTILITIES/STRUCTURES MAY BE ENCOUNTERED. THE STATUS OF UTILITIES, WHETHER ACTIVE, ABANDONED, OR REMOVED, IS AN UNKNOWN CONDITION.
- THE ACCURACY OF MEASURED UTILITY INVERTS AND PIPE SIZES IS SUBJECT TO FIELD CONDITIONS, THE ABILITY TO MAKE VISUAL OBSERVATIONS, DIRECT ACCESS TO THE VARIOUS ELEMENTS AND OTHER MATTERS.
- RIGHT-OF-WAY LINE AND ADJUTER PROPERTY LINE INFORMATION SHOWN HEREON ARE APPROXIMATE AND ARE NOT WARRANTED TO BE EXACT.
- CONTRACTOR SHALL VERIFY FIELD CONDITIONS BEFORE COMMENCEMENT OF ANY CONSTRUCTION ACTIVITIES. CONTRACTOR SHALL VERIFY EXISTING ELEVATIONS AND DIMENSIONS WHERE NEW WORK WILL MATCH EXISTING. DISCREPANCIES SHALL BE BROUGHT TO THE ATTENTION OF THE AUTHORITY FOR RESOLUTION PRIOR TO THE COMMENCEMENT OF WORK.
- THE CONTRACTOR SHALL BE RESPONSIBLE FOR CONTACTING AND NOTIFYING THE PROPER UTILITY COMPANY AND UTILITY LOCATING SERVICES PRIOR TO CONSTRUCTION.
- CONTRACTOR SHALL TAKE CARE TO AVOID DAMAGE TO EXISTING PAVEMENT, TREES, VEGETATION, STRUCTURES, AND UTILITIES THAT ARE NOT INDICATED TO BE DEMOLISHED, REMOVED, OR RELOCATED. ANY DAMAGE TO EXISTING PAVEMENT, TREES, VEGETATION, STRUCTURES, AND UTILITIES NOT INDICATED TO BE DEMOLISHED, REMOVED OR RELOCATED SHALL BE REPAIRED AT NO ADDITIONAL COST TO THE AUTHORITY.
- WHERE PROPOSED WORK IS IN THE VICINITY OF UTILITY POLES, SUCH THAT SUPPORT OF THE POLE(S) WILL BE REQUIRED, THE CONTRACTOR SHALL BE RESPONSIBLE FOR NOTIFYING THE UTILITY, PUBLIC OR PRIVATE, OF THE WORK. IT WILL BE THE RESPONSIBILITY OF THE CONTRACTOR TO COORDINATE WITH THE UTILITY FOR SUPPORT OF THE POLE.
- WHERE OVERHEAD POWER LINES ARE PRESENT, CONTRACTOR MUST CONTACT THE UTILITY PRIOR TO CONSTRUCTION ACTIVITIES TO DETERMINE THE MINIMUM REQUIRED EQUIPMENT CLEARANCE (MEC) DISTANCE.
- THE CONTRACTOR SHALL REMOVE AND LEGALLY DISPOSE OF ALL DEBRIS GENERATED DURING THE PROJECT OFF SITE AT A PROPERLY PERMITTED DISPOSAL FACILITY.
- CONTRACTOR SHALL MAKE EVERY EFFORT TO SAVE AND MAINTAIN ALL PROPERTY IRONS, MONUMENTS, OTHER PERMANENT POINTS AND LINES OF REFERENCE AND CONSTRUCTION STAKES. A MASSACHUSETTS REGISTERED LAND SURVEYOR SHALL REPLACE PROPERTY IRONS, MONUMENTS, AND OTHER PERMANENT POINTS OF REFERENCE DESTROYED BY THE CONTRACTOR, AT NO ADDITIONAL COST TO THE AUTHORITY.

REFERENCE MONUMENT NAME/NUMBER	COORDINATES	ELEVATION
NAIL IN UTILITY POLE #125	N2955131 E799952	16.56 BCB
CHISEL-SO FOUND ON CORNER OF CONC. PAD	N2954979 E800197	18.67 BCB



Hazen
HAZEN AND SAWYER
24 FEDERAL STREET, 5TH FLOOR
BOSTON, MASSACHUSETTS 02110

REG. PROF. ENGR. _____ DATE _____
REG. PROF. ENGR. _____ DATE _____

SCALE: AS SHOWN									
DESIGNED BY: KTR									
DRAWN BY: KTR									
CHECKED BY: AA									
APPROVED BY: AA									
NUMBER	DATE	MADE BY	CHECKED BY	REVISIONS					
				DESCRIPTION					

MASSACHUSETTS WATER RESOURCES AUTHORITY
DEER ISLAND TREATMENT PLANT

**PARKING LOT MODIFICATIONS
CIVIL LEGEND, ABBREVIATIONS
AND NOTES**

MAY 2020

PROJECT NO.	
CONTRACT NO.	7645
CAD FILE NO.	7645_TO4_C-001
SHEET NO.	7645_TO4_C-001

- NOTES:
1. INSTALL PERIMETER EROSION CONTROLS AND INLET PROTECTION PRIOR TO COMMENCING DEMOLITION WORK.
 2. TRUCKS OR HEAVY EQUIPMENT SHALL NOT BE ALLOWED WITHIN TREE PROTECTION LIMITS. ONLY HAND LABOR WILL BE ALLOWED. CONSTRUCTION MATERIALS, SOIL DEPOSITS, OR SOLVENTS SHALL NOT BE ALLOWED WITHIN TREE PROTECTION LIMITS.
 3. ALL TREE PROTECTION MEASURES ARE TO BE IN PLACE PRIOR TO CONSTRUCTION ACTIVITIES NEAR TREES. TREE PROTECTION IS TO REMAIN IN PLACE AND MAINTAINED UNTIL CONSTRUCTION IS COMPLETE AND ALL HEAVY EQUIPMENT IS REMOVED FROM THE AREA. DETAIL FOR TREE PROTECTION CAN BE FOUND ON DRAWING NO. C-007.
 4. LOCATION OF EXISTING TREES/SHRUBS TO BE REMOVED IS APPROXIMATE. FINAL LOCATION TO BE DETERMINED IN THE FIELD BY THE AUTHORITY.
 5. FOR ELECTRICAL DEMOLITION WORK, SEE TO DRAWING NO. E-002.
 6. LIMITS OF SAWCUTTING SHALL BE AT THE LIMITS OF DEMOLITION AS INDICATED ON THIS SHEET AND DRAWING NO. E-002, AND AT THE LIMITS OF NEW WORK AS INDICATED ON DRAWING NO. C-003 THROUGH E-003.

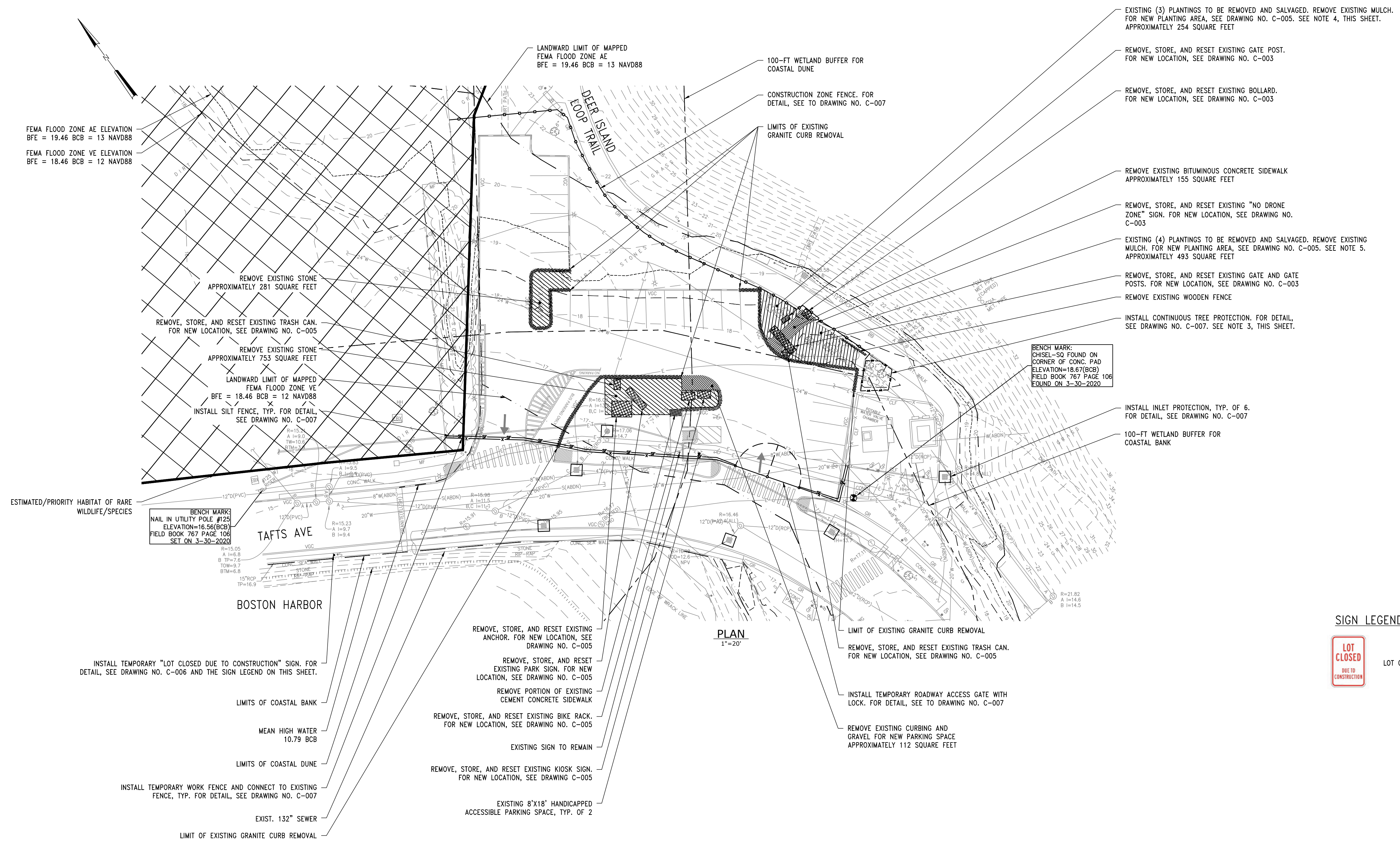

- EXISTING (3) PLANTINGS TO BE REMOVED AND SALVAGED. REMOVE EXISTING MULCH. FOR NEW PLANTING AREA, SEE DRAWING NO. C-005. SEE NOTE 4, THIS SHEET. APPROXIMATELY 254 SQUARE FEET
- REMOVE, STORE, AND RESET EXISTING GATE POST. FOR NEW LOCATION, SEE DRAWING NO. C-003
- REMOVE, STORE, AND RESET EXISTING BOLLARD. FOR NEW LOCATION, SEE DRAWING NO. C-003
- REMOVE EXISTING BITUMINOUS CONCRETE SIDEWALK APPROXIMATELY 155 SQUARE FEET
- REMOVE, STORE, AND RESET EXISTING "NO DRONE ZONE" SIGN. FOR NEW LOCATION, SEE DRAWING NO. C-003
- EXISTING (4) PLANTINGS TO BE REMOVED AND SALVAGED. REMOVE EXISTING MULCH. FOR NEW PLANTING AREA, SEE DRAWING NO. C-005. SEE NOTE 5. APPROXIMATELY 493 SQUARE FEET
- REMOVE, STORE, AND RESET EXISTING GATE AND GATE POSTS. FOR NEW LOCATION, SEE DRAWING NO. C-003
- REMOVE EXISTING WOODEN FENCE
- INSTALL CONTINUOUS TREE PROTECTION. FOR DETAIL, SEE DRAWING NO. C-007. SEE NOTE 3, THIS SHEET.
- INSTALL INLET PROTECTION, TYP. OF 6. FOR DETAIL, SEE DRAWING NO. C-007
- 100-FT WETLAND BUFFER FOR COASTAL BANK

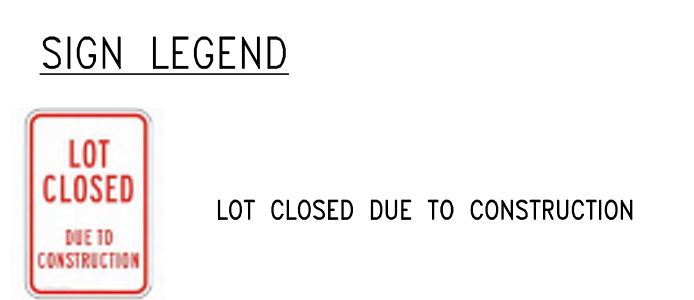

Hazen
 HAZEN AND SAWYER
 24 FEDERAL STREET, 5TH FLOOR
 BOSTON, MASSACHUSETTS 02110

REG. PROF. ENGR. _____ DATE _____
 REG. PROF. ENGR. _____ DATE _____

SCALE: AS SHOWN
ALL DIMENSIONS UNLESS OTHERWISE NOTED OR INDICATED BY REVISION

DESIGNED BY: KTR					
DRAWN BY: KTR					
CHECKED BY: AA					
APPROVED BY: AA					

NUMBER	DATE	MADE BY	CHECKED BY	DESCRIPTION

MASSACHUSETTS WATER RESOURCES AUTHORITY
 DEER ISLAND TREATMENT PLANT

**PARKING LOT MODIFICATIONS
 EXISTING CONDITIONS, DEMOLITION AND
 EROSION AND SEDIMENT CONTROL PLAN**

PROJECT NO. _____
 CONTRACT NO. 7645
 CAD FILE NO. 7645_T04_C-002
 SHEET NO. 7645_T04_C-002

CIVIL MAY 2020

NOTES:

- ONE HANDICAPPED SPACE IS DESIGNATED FOR VAN PARKING AND REQUIRES AN EIGHT FOOT WIDE ACCESS AISLE AS INDICATED. THIS PARKING SPACE SHALL BE IDENTIFIED AS "VAN ACCESSIBLE" WITH SIGNAGE.
- THE CONTRACTOR SHALL FURNISH AND INSTALL PAVEMENT MARKINGS AND SIGNAGE AS INDICATED, COMPLIANT WITH MASS DOT STANDARDS. PAVEMENT MARKINGS SHALL CONFORM TO MASS DOT STANDARD SECTION M7.01.03 FOR WHITE MARKINGS AND M7.01.04 FOR YELLOW MARKINGS AND US DOT CHAPTER 38.18. CONVENTIONAL PARKING SPACES ARE NINE FEET IN WIDTH. HANDICAPPED PARKING SPACES ARE EIGHT FEET IN WIDTH AND SHARE A COMMON ACCESS AISLE.
- FOR NEW PARKING SPACES BEING INSTALLED OVER EXISTING PAVEMENT SURFACES, CONTRACTOR SHALL INSTALL NEW PERMANENT PAVEMENT. FOR DETAIL SEE TO DRAWING NO. C-006.

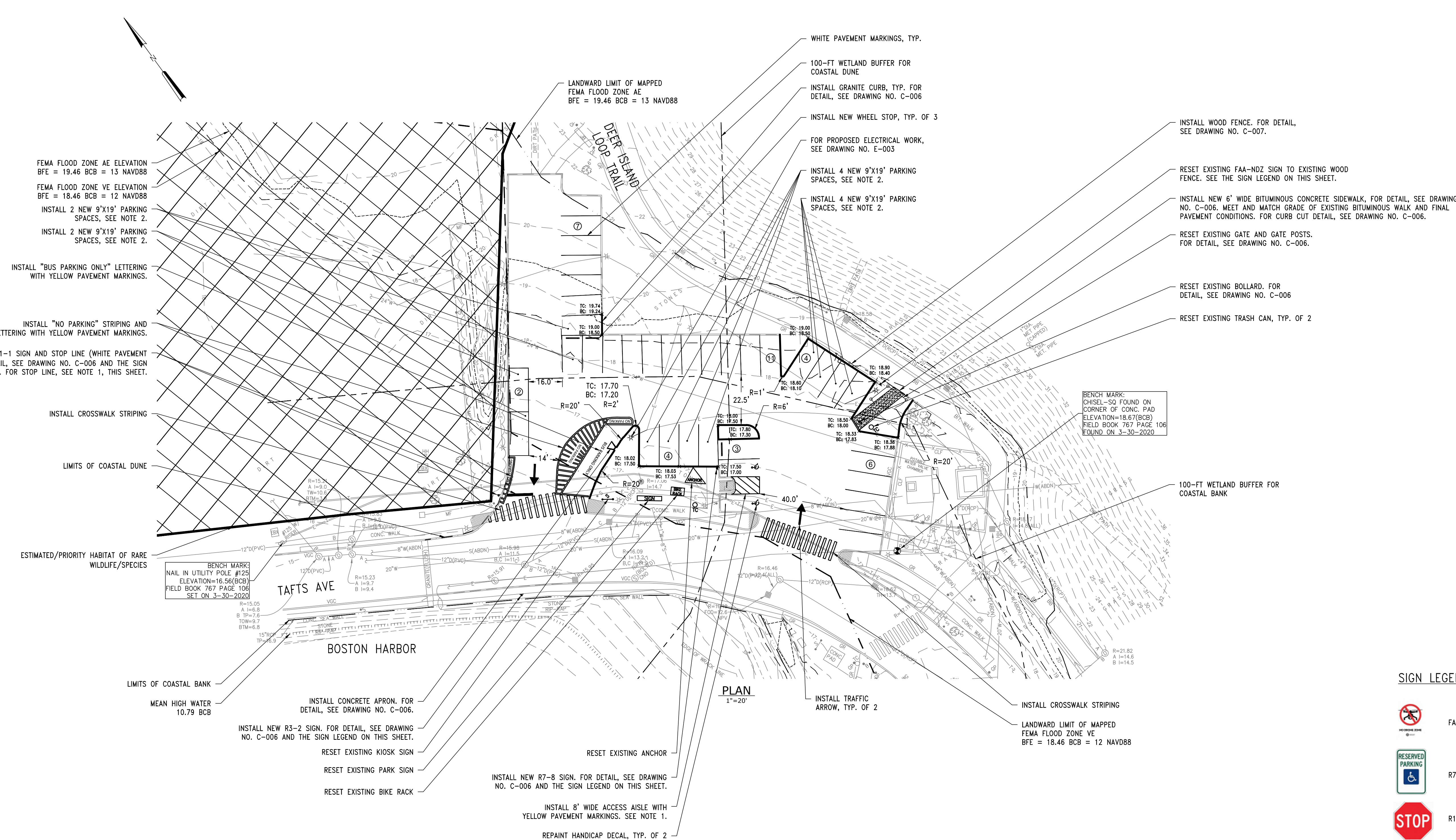

SIGN LEGEND

-  FAA-NDZ
-  R7-8
-  R1-1
-  R3-2



Hazen
HAZEN AND SAWYER
24 FEDERAL STREET, 5TH FLOOR
BOSTON, MASSACHUSETTS 02110

REG. PROF. ENGR.	DATE
REG. PROF. ENGR.	DATE

SCALE: AS SHOWN		DESIGNED BY: KTR		DRAWN BY: KTR		CHECKED BY: AA		APPROVED BY: AA	
NUMBER	DATE	MADE BY	CHECKED BY	REVISIONS		DESCRIPTION			

MASSACHUSETTS WATER RESOURCES AUTHORITY
DEER ISLAND TREATMENT PLANT
**PARKING LOT MODIFICATIONS
PARKING AREA SITE LAYOUT**

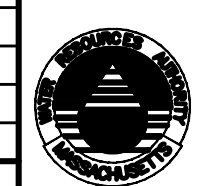

PROJECT NO.	
CONTRACT NO.	7645
CAD FILE NO.	7645_T04_C-003
SHEET NO.	7645_T04_C-003

CIVIL MAY 2020

- NOTES:
- CONTRACTOR SHALL PERFORM GEOTECHNICAL INVESTIGATIONS AT THE LEACHING CATCH BASIN LOCATION CONSISTING OF ONE BORING (15 FT DEPTH) AND A FALLING-HEAD IN-SITU PERMEABILITY TEST (ASTM D5126-90 METHOD) AT 5FT AND 10FT DEPTH INTERVAL. PROVIDE SUBSURFACE INFORMATION RESULTS AND GROUNDWATER TABLE IF ENCOUNTERED TO THE AUTHORITY PRIOR TO THE INSTALLATION OF THE LEACHING CATCH BASIN. UPON REVIEW OF THE RESULTS, IT MAY BE REQUIRED TO MAKE MODIFICATIONS TO THE DEPTH AND LOCATION OF THE LEACHING CATCH BASIN.
 - THE LEACHING CATCH BASIN SHALL HAVE A MINIMUM OF 120 CF STORAGE CAPACITY.

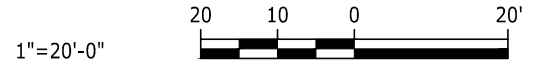
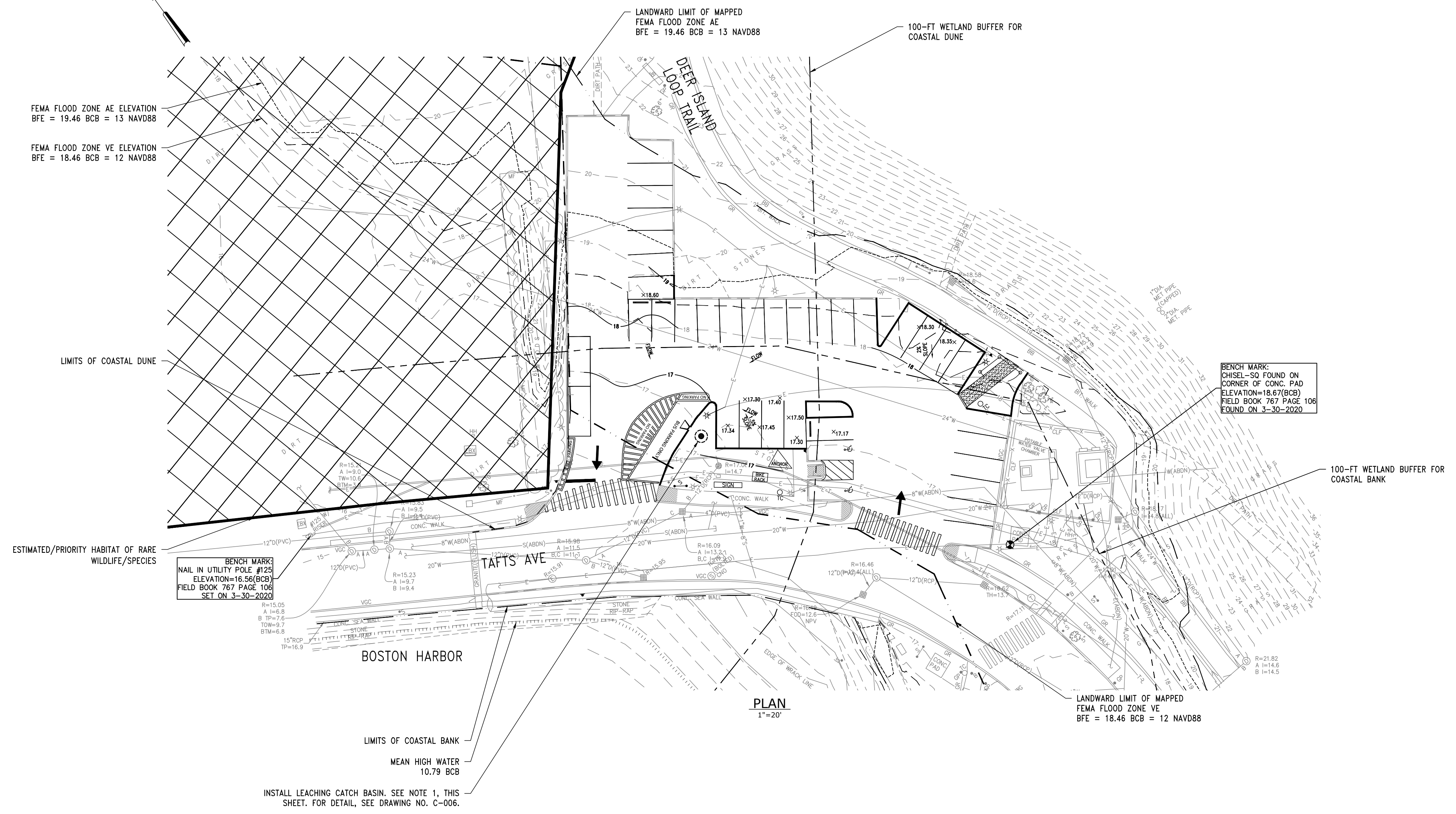

Hazen
HAZEN AND SAWYER
24 FEDERAL STREET, 5TH FLOOR
BOSTON, MASSACHUSETTS 02110

REG. PROF. ENGR. _____ DATE _____
REG. PROF. ENGR. _____ DATE _____

SCALE: AS SHOWN
DESIGNED BY: KTR
DRAWN BY: KTR
CHECKED BY: AA
APPROVED BY: AA

NUMBER	DATE	MADE BY	CHECKED BY	DESCRIPTION

MASSACHUSETTS WATER RESOURCES AUTHORITY
DEER ISLAND TREATMENT PLANT

**PARKING LOT MODIFICATIONS
STORMWATER INFILTRATION SYSTEM
AND GRADING PLAN**

PROJECT NO. _____
CONTRACT NO. 7645
CAD FILE NO. 7645_T04_C-004
SHEET NO. 7645_T04_C-004

CIVIL MAY 2020

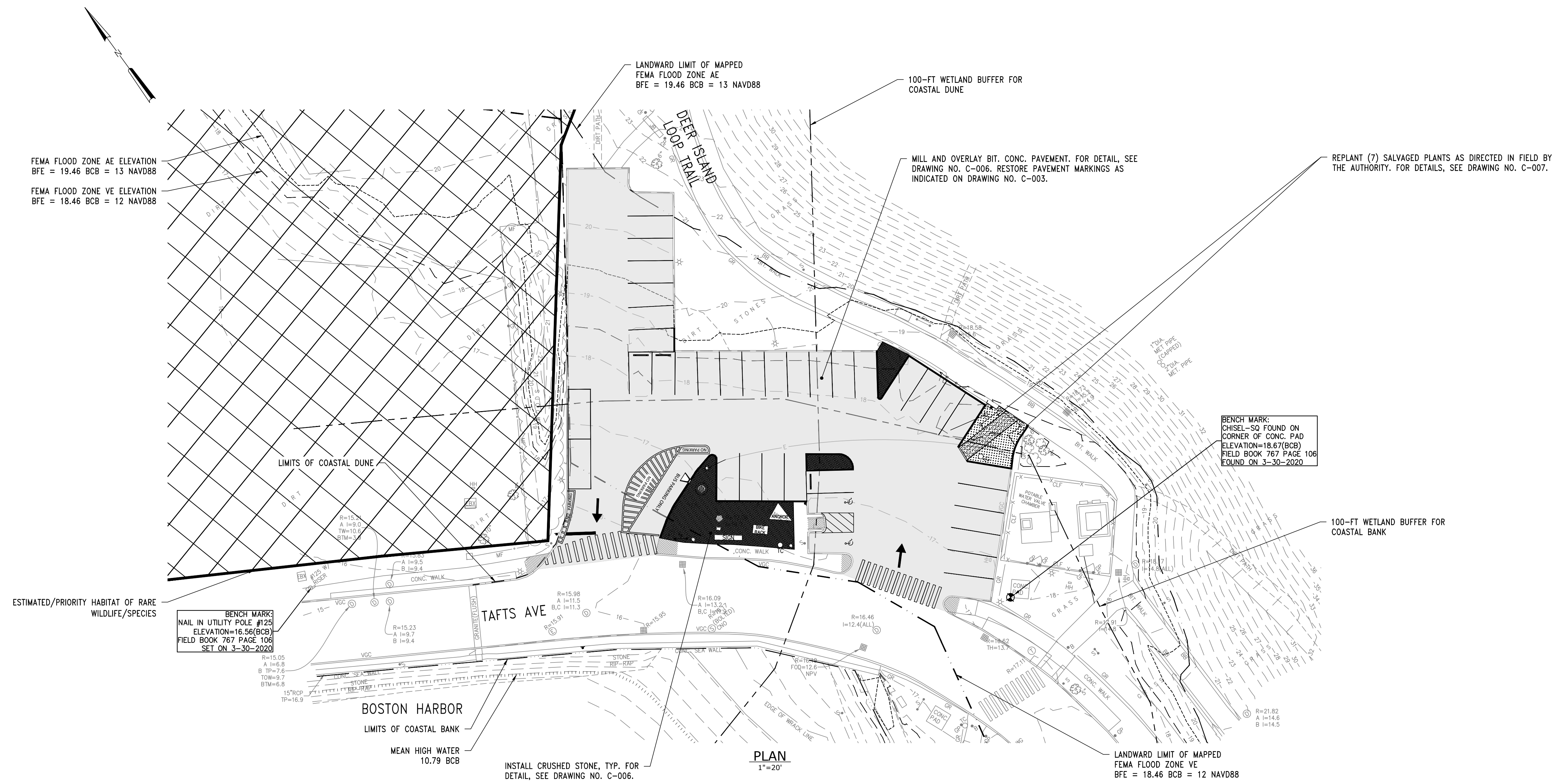

Hazen
HAZEN AND SAWYER
24 FEDERAL STREET, 5TH FLOOR
BOSTON, MASSACHUSETTS 02110

REG. PROF. ENGR. _____ DATE _____
REG. PROF. ENGR. _____ DATE _____

SCALE: AS SHOWN
UNLESS OTHERWISE NOTED OR
CHANGED BY REVISION

DESIGNED BY: KTR
DRAWN BY: KTR
CHECKED BY: AA
APPROVED BY: AA

NUMBER	DATE	MADE BY	CHECKED BY	REVISIONS	DESCRIPTION

MASSACHUSETTS WATER RESOURCES AUTHORITY
DEER ISLAND TREATMENT PLANT
PARKING LOT MODIFICATIONS
FINAL SITE PLAN

CIVIL
MAY 2020

PROJECT NO. _____
CONTRACT NO. 7645
CAD FILE NO. 7645_T04_C-005
SHEET NO. 7645_T04_C-005

EROSION AND SEDIMENT CONTROL NOTES:

1. DUE TO THE NATURE OF THE WORK REQUIRED BY THIS CONTRACT, IT IS ANTICIPATED THE LOCATION AND NATURE OF EROSION AND SEDIMENT CONTROL MEASURES WILL BE ADJUSTED AS CONSTRUCTION PROGRESSES AS REQUIRED TO REFLECT THE CURRENT PHASE OF WORK. THE CONSTRUCTION SCHEDULE ADOPTED BY THE CONTRACTOR WILL IMPACT THE PLACEMENT AND NEED FOR SPECIFIC DEVICES REQUIRED FOR THE CONTROL OF EROSION. THE LOCATION AND EXTENT OF EROSION AND SEDIMENT CONTROL MEASURES SHALL BE REVISED AT EACH PHASE OF CONSTRUCTION FOR THE QUANTITY OR DIRECTION OF SURFACE RUNOFF FROM THE CONSTRUCTION AREAS AS A RESULT OF THAT CONSTRUCTION PHASE.
2. EROSION AND SEDIMENT CONTROLS SHALL BE INSTALLED AS INDICATED ON THE DRAWINGS.
3. CONTRACTOR SHALL OBTAIN PRIOR APPROVAL, IN WRITING, FROM THE AUTHORITY FOR DEVIATIONS FROM THE APPROVED EROSION AND SEDIMENT CONTROL PLAN.
4. NO LAND DISTURBANCE, DEMOLITION OR CONSTRUCTION ACTIVITIES SHALL BEGIN UNTIL ALL PERIMETER EROSION AND SEDIMENT CONTROL MEASURES, INCLUDING, BUT NOT LIMITED TO, SILT FENCING, INLET PROTECTION, TEMPORARY DIVERSIONS, AND TREE PROTECTION HAVE BEEN INSTALLED AS INDICATED ON THE CONTRACT DRAWINGS. IF CLEARING IS REQUIRED FOR INSTALLATION OF A PARTICULAR MEASURE, ALL MEASURES NOT REQUIRING CLEARING SHALL BE INSTALLED FIRST. CLEARING OF THE NECESSARY LAND FOR INSTALLATION OF THE PARTICULAR MEASURE MAY THEN PROCEED.
5. CLEARING SHALL BE LIMITED AS MUCH AS POSSIBLE TO AREAS REQUIRED FOR CURRENT CONSTRUCTION ACTIVITIES. MASS CLEARING AND GRADING SHALL BE AVOIDED.
6. ALL EROSION CONTROL MEASURES SHALL BE INSPECTED WITHIN 24 HOURS FOLLOWING EVERY RAINFALL, BUT IN NO CASE LESS THAN ONCE EVERY SEVEN CALENDAR DAYS, TO ENSURE THE EROSION CONTROL MEASURES ARE IN PROPER WORKING ORDER, AND THAT ANY REQUIRED REPAIRS ARE MADE IN A TIMELY FASHION. THE AUTHORITY MAY INSPECT EROSION CONTROL MEASURES AT ANY TIME AND REQUIRE REPAIRS OR MODIFICATIONS AS REQUIRED TO MAINTAIN THE EROSION CONTROL SYSTEM IN GOOD WORKING ORDER.
7. EROSION AND SEDIMENT CONTROL MEASURES SHALL BE REPAIRED OR REPLACED IMMEDIATELY AS REQUIRED TO MAINTAIN PERFORMANCE OF MEASURE. MEASURES SHALL BE CLEANED WHEN SEDIMENT VOLUME REACHES 1/2 OF TOTAL VOLUME OF MEASURE. REMOVED SEDIMENT SHALL BE DISPOSED OF IN SUCH A MANNER AND LOCATION AS TO INSURE FURTHER SEDIMENT TRANSPORT DOES NOT OCCUR.
8. CONTRACTOR SHALL INITIATE STABILIZATION MEASURES AS SOON AS PRACTICABLE ON STOCKPILES AND IN PORTIONS OF THE SITE WHERE CONSTRUCTION ACTIVITIES HAVE TEMPORARILY OR PERMANENTLY CEASED, BUT IN NO CASE MORE THAN 7 DAYS AFTER THE CONSTRUCTION ACTIVITY IN THAT PORTION OF THE SITE HAS TEMPORARILY OR PERMANENTLY CEASED. THIS REQUIREMENT DOES NOT APPLY IN THE FOLLOWING INSTANCES:
9. SOIL STOCKPILE AND LAYDOWN AREAS SHALL HAVE PERIMETER SEDIMENT CONTROL MEASURES AND TEMPORARY OR PERMANENT STABILIZATION MEASURES INSTALLED AS SOON AS POSSIBLE AND AT COMPLETION OF STOCKPILING AND LAYDOWN ACTIVITIES. STOCKPILE SIDE SLOPES SHALL NOT EXCEED 3H:1V UNLESS APPROVED BY THE AUTHORITY. TOP OF STOCKPILE SHALL BE GRADED WITH A MINIMUM 5% SLOPE TO INSURE PROPER DRAINAGE.
10. ALL DISTURBED AREAS, EXCEPT FOR CONCRETE AND PAVED AREAS, SHALL BE MULCHED AND/OR A STONE LAYER INSTALLED IN ACCORDANCE WITH THE SPECIFICATIONS AND THE SEEDING SCHEDULE, AND RE-SEEDED AS NECESSARY, TO ESTABLISH AND MAINTAIN A VIGOROUS, DENSE VEGETATIVE COVER.
11. ALL POINTS OF CONSTRUCTION INGRESS AND EGRESS SHALL BE PROTECTED TO PREVENT THE DEPOSITION OF MATERIALS ONTO TRAVERSED OFFSITE ROADWAYS. IF MATERIAL IS TRACKED ONTO OFFSITE ROADWAYS, IT SHALL BE REMOVED IMMEDIATELY. DO NOT UTILIZE A WATER HOSE TO CLEAN ROADS UNLESS THE RUNOFF IS DIRECTED TO A PROPERLY DESIGNED AND FUNCTIONING SEDIMENT CONTROL DEVICE. PROPER PRECAUTIONS SHALL BE TAKEN TO ENSURE THAT MATERIALS DEPOSITED ONTO OFFSITE ROADWAYS ARE REMOVED SO THAT THEY DO NOT ENTER YARD INLETS, CATCH BASINS, SEWERS, WETLANDS, SURFACE WATER BODIES, OR ROADSIDE SWALES.
12. EARTHEN-MATERIAL STOCKPILES SHALL BE LOCATED A MINIMUM OF 50' FROM STORM DRAINS AND STREAMS UNLESS NO REASONABLE ALTERNATIVES ARE AVAILABLE.
13. DEDICATED AREAS FOR DEMOLITION, CONSTRUCTION, AND OTHER WASTES SHALL BE LOCATED A MINIMUM OF 50' FROM STORM DRAINS AND STREAMS UNLESS NO REASONABLE ALTERNATIVES ARE AVAILABLE.
14. ALL WORK PERFORMED SHALL BE IN ACCORDANCE WITH THE 'MASSACHUSETTS EROSION AND SEDIMENT CONTROL GUIDELINES FOR URBAN AND SUBURBAN AREAS MANUAL', LATEST EDITION, AND IN ACCORDANCE WITH THE CONTRACT DOCUMENTS.
15. STAGING AREA, STOCKPILES, AND OTHER STORAGE LOCATIONS SHALL BE PROTECTED FROM EROSION. ANY EXCAVATED SPOILS REMOVED FROM THE SITE SHALL BE TRANSPORTED IN A SEALED/WATERTIGHT CONTAINER AND DISPOSED OF AT AN APPROVED FACILITY.
16. PAVED ROADWAYS SHALL BE KEPT CLEAN AT ALL TIMES. DO NOT UTILIZE A FIRE OR GARDEN HOSE TO CLEAN ROADS UNLESS THE RUNOFF IS DIRECTED TO A PROPERLY DESIGNED AND FUNCTIONING SEDIMENT CONTROL DEVICE. WATER PUMPED OUT OF THE EXCAVATED AREAS CONTAINS SEDIMENTS THAT SHALL BE REMOVED PRIOR TO DISCHARGING TO RECEIVING BODIES OF WATER USING REMOVABLE PUMPING STATIONS, SUMP PITS, PORTABLE SEDIMENTATION TANKS AND/OR SILT CONTROL BAGS.
17. THE CONTRACTOR SHALL BE RESPONSIBLE FOR THE DESIGN, INSTALLATION, PERMITTING, AND OPERATION OF A DEWATERING SYSTEM AS REQUIRED FOR THE COMPLETION OF THE WORK. PROCEDURES FOR DEWATERING INCLUDING ASSOCIATED EROSION AND SEDIMENT CONTROL PROPOSED BY THE CONTRACTOR SHALL BE SUBMITTED TO THE AUTHORITY FOR REVIEW PRIOR TO ANY EARTHWORK OPERATIONS. ALL WATER REMOVED BY DEWATERING OPERATIONS SHALL BE DISPOSED OF IN ACCORDANCE WITH MADEP PROCEDURES AND STANDARDS FOR URBAN SOIL EROSION AND SEDIMENT CONTROL.
18. ALL EROSION AND SEDIMENT CONTROL MEASURES SHALL REMAIN IN PLACE UNTIL CONSTRUCTION IS COMPLETE, PERMANENT VEGETATION IS ESTABLISHED ON ALL DISTURBED AREAS, AND LOCAL AUTHORITIES HAVE GIVEN PERMISSION FOR REMOVAL.
19. ALL STORM DRAINAGE INLETS SHALL BE PROTECTED BY ONE OF THE PRACTICES ACCEPTED IN THE STANDARDS, AND PROTECTION SHALL REMAIN UNTIL PERMANENT STABILIZATION HAS BEEN ESTABLISHED. STORM DRAINAGE OUTLET POINTS SHALL BE PROTECTED AS REQUIRED BEFORE THEY BECOME FUNCTIONAL.

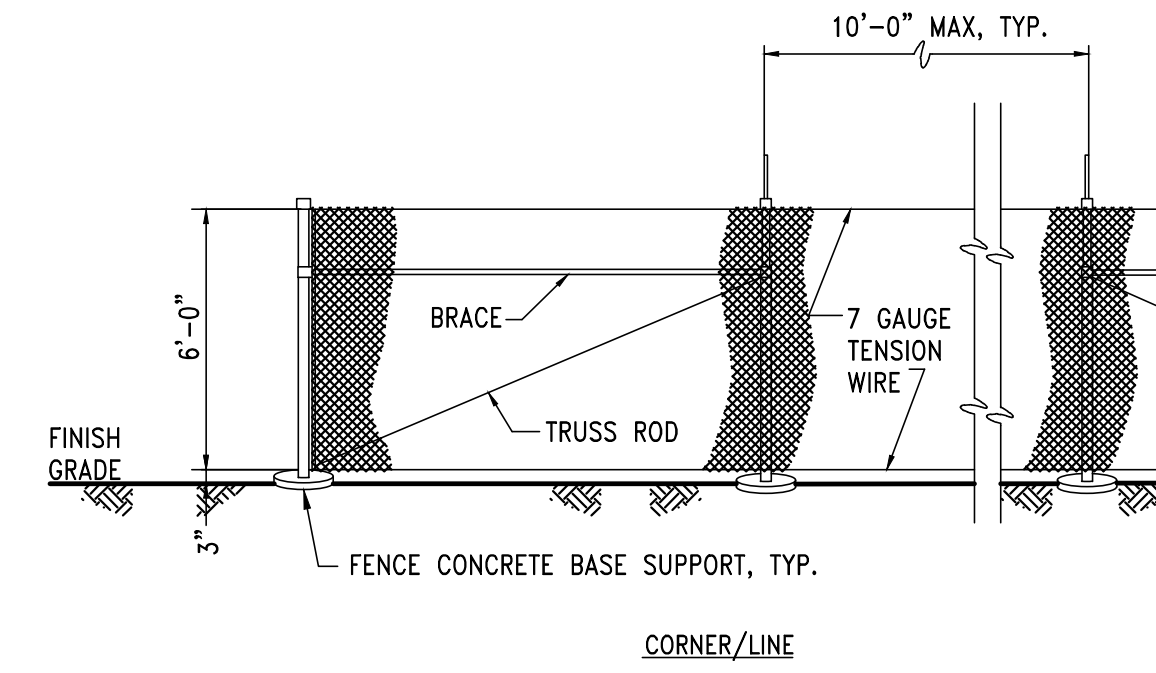

NOTE:
1. CONTRACTOR SHALL BE RESPONSIBLE FOR ENSURING TEMPORARY FENCE BASE SUPPORTS ARE SIZED APPROPRIATELY TO RESIST WIND LOADING.

TEMPORARY CHAIN LINK FENCE

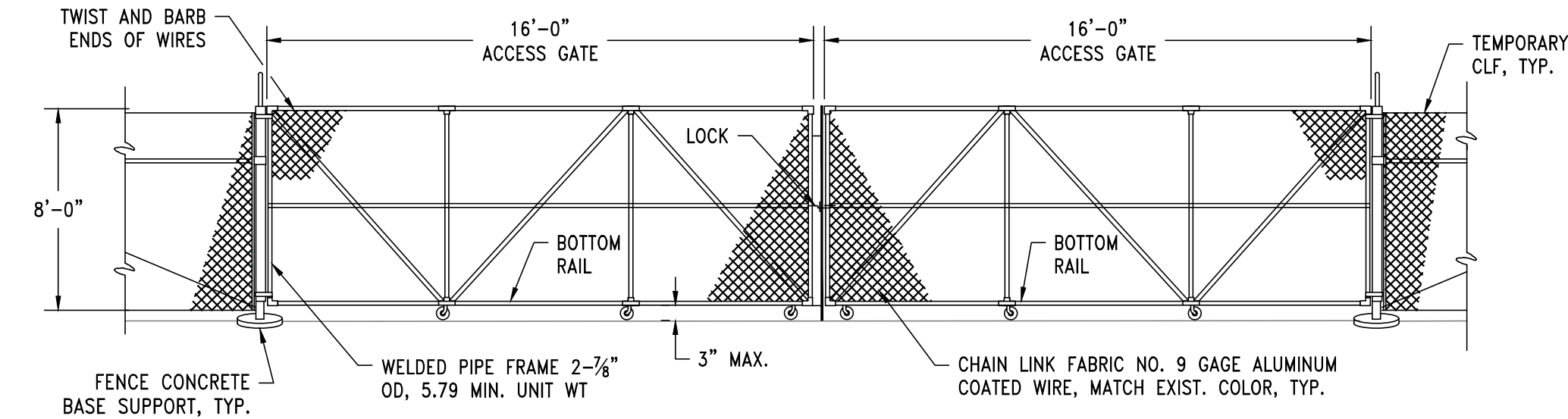

TEMPORARY ROADWAY DOUBLE ACCESS GATE

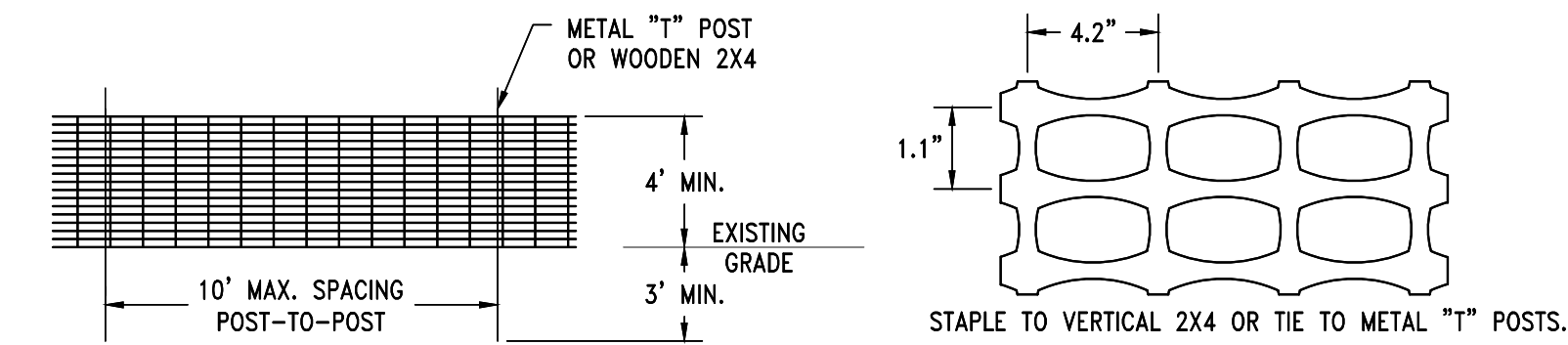

CONSTRUCTION ZONE FENCE

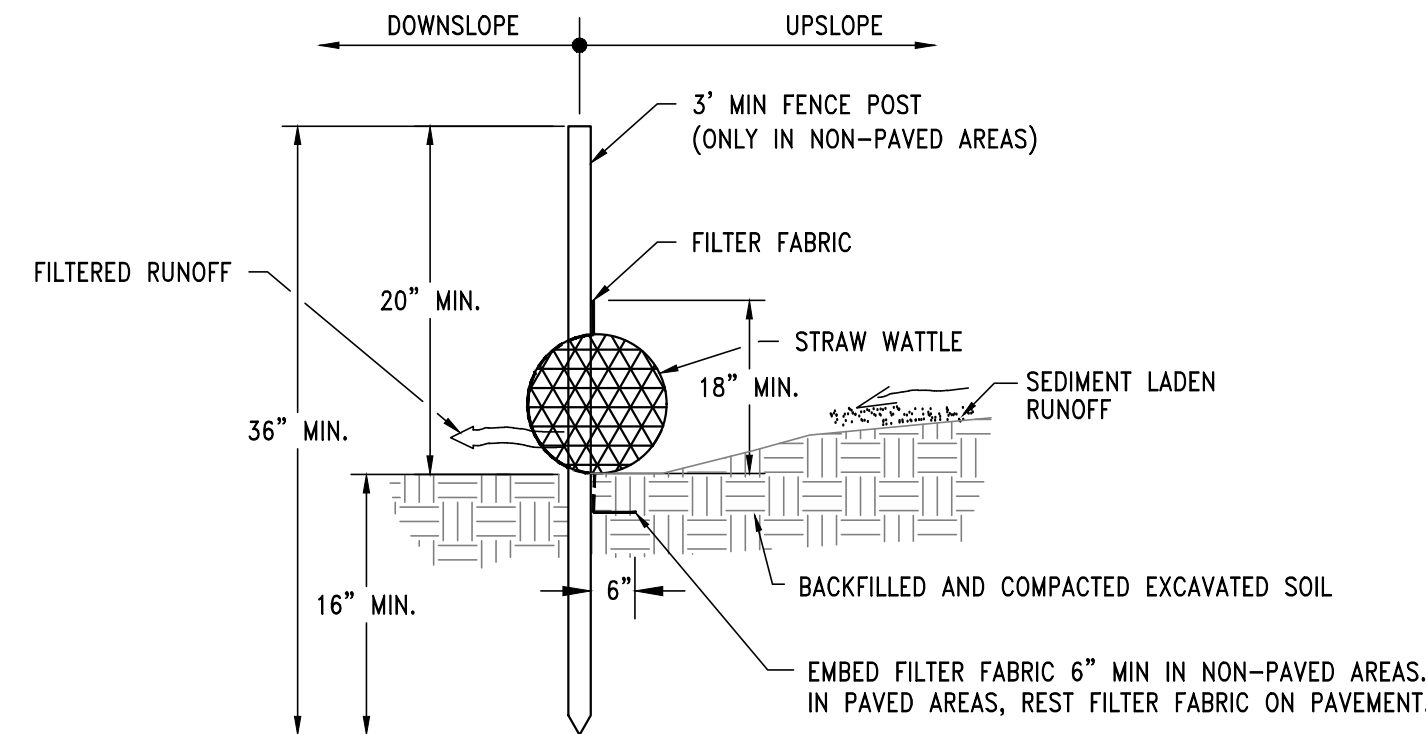
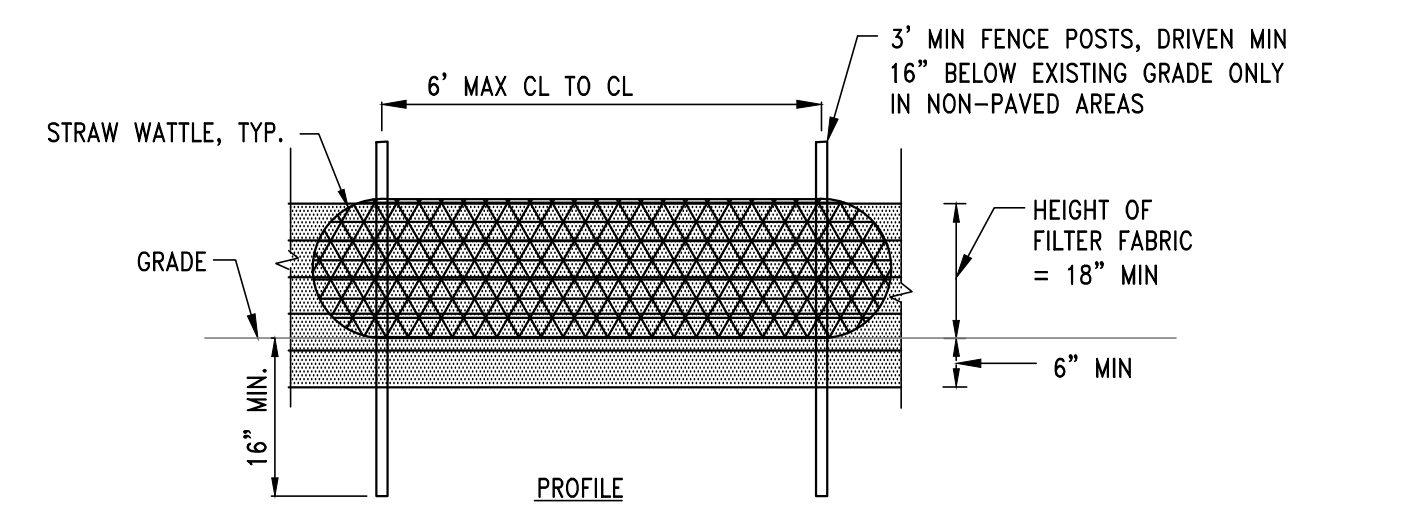
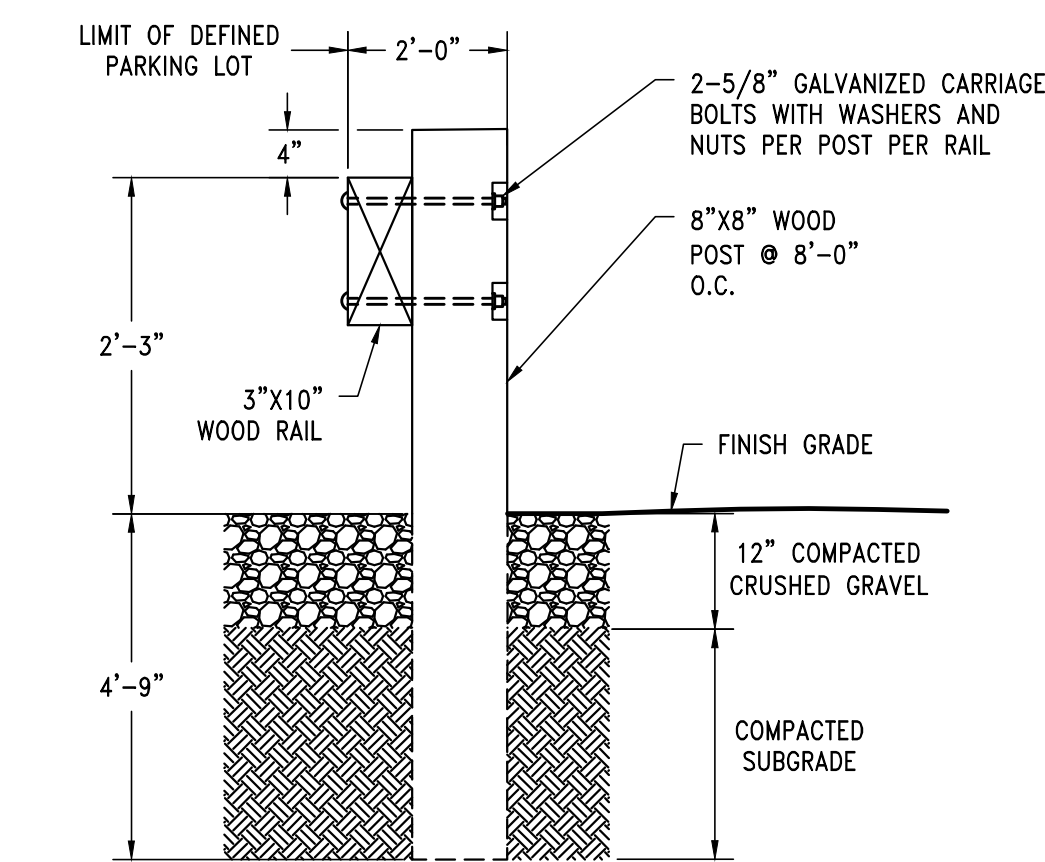
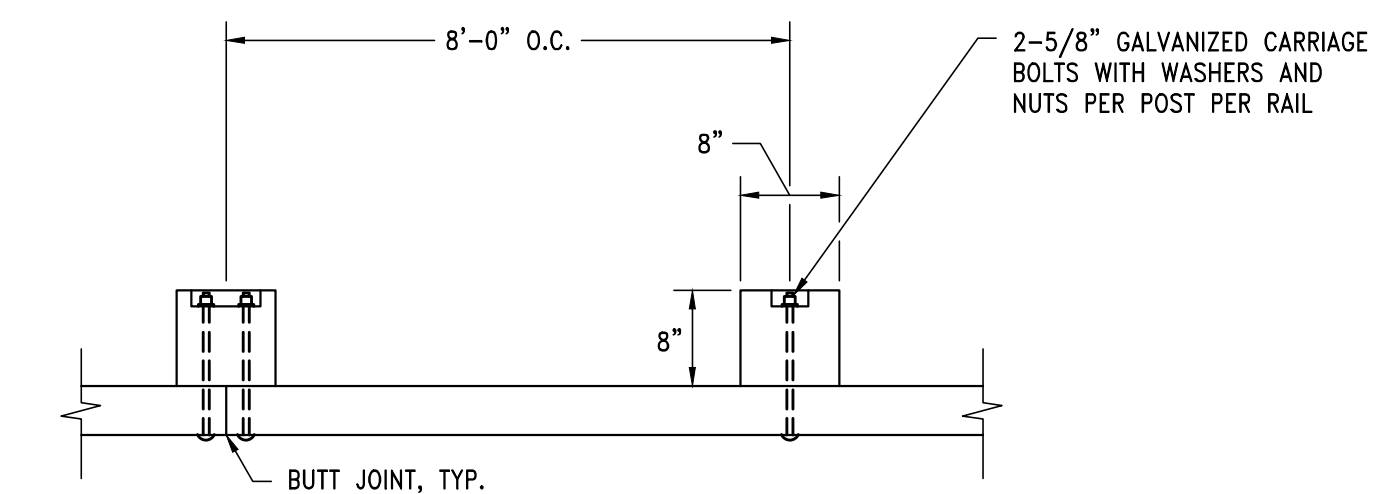

CONSTRUCTION SPECIFICATIONS

1. FILTER FABRIC TO BE FASTENED SECURELY TO TEMPORARY CHAIN LINK FENCE IN PAVED AREAS. TIES SHALL BE SPACED EVERY 12 INCHES AT TOP AND MID SECTION. FILTER FABRIC SHALL BE NO MORE THAN 18-INCHES ABOVE GRADE.
 2. WHEN TWO SECTIONS OF FILTER FABRIC ADJOIN EACH OTHER, THEY SHALL BE OVERLAPPED BY SIX INCHES AND FOLDED.
 3. MAINTENANCE SHALL BE PERFORMED REGULARLY AND MATERIAL REMOVED WHEN BULGES OR HOLES DEVELOP IN THE SILT FENCE, OR AS REQUIRED BY THE ENGINEER.
 4. MAXIMUM ALLOWABLE SLOPE LENGTHS CONTRIBUTING RUNOFF TO A SILT FENCE ARE:
- | SLOPE STEEPNESS | MAXIMUM SLOPE LENGTH (FT) |
|-----------------|---------------------------|
| 2:1 | 25 |
| 3:1 | 50 |
| 4:1 | 75 |
| 5:1 OR FLATTER | 100 |
5. MAXIMUM DRAINAGE AREA FOR OVERLAND FLOW TO A SILT FENCE SHALL NOT EXCEED 1/2 ACRE PER 100 FEET OF FENCE.

SILT FENCE DETAIL

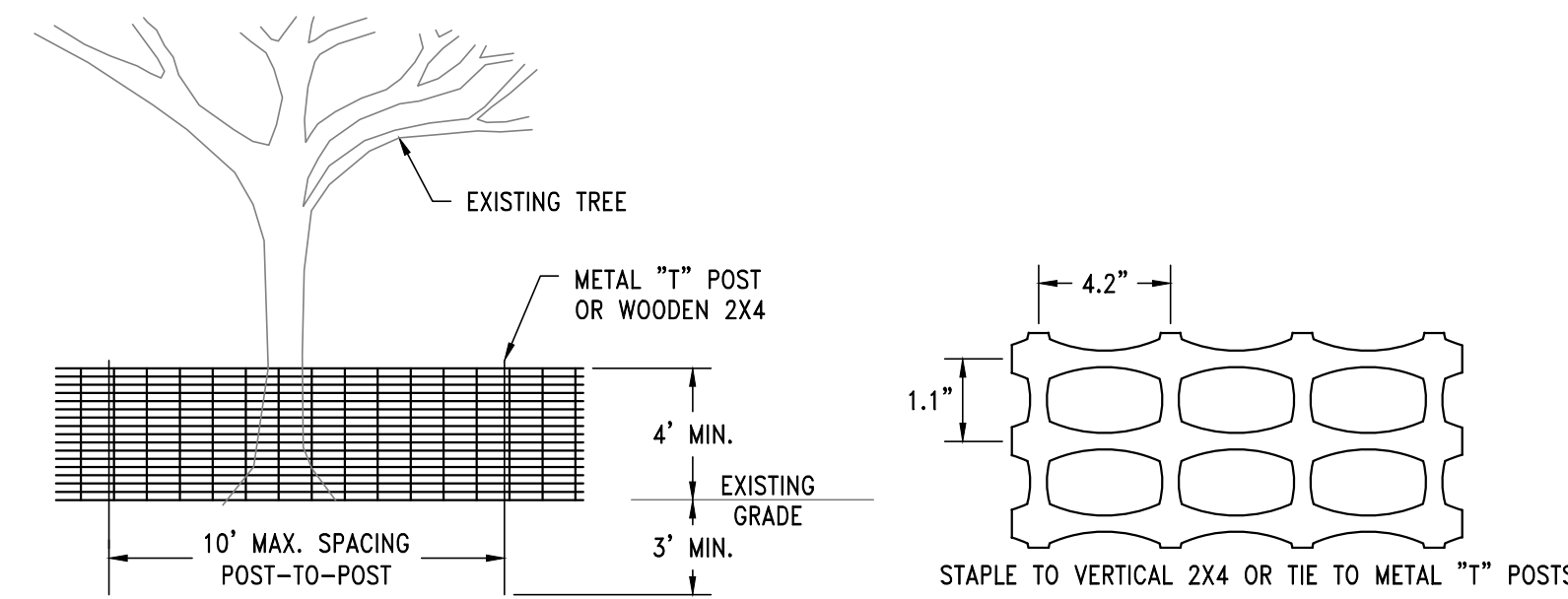

- NOTES:**
1. PLACE CONTINUOUS RUN OF FENCE MATERIAL ON BOTH SIDES OF IMMEDIATE WORK ZONE IN WOODED AREAS AS SHOWN ON THE PLANS. DO NOT ATTACH FENCE MATERIAL TO TREES.
 2. TREE PROTECTION FENCING FABRIC TO BE PLACED AT THE DRIP LINE OF THE TREES THAT ARE TO BE PROTECTED.
 3. ONE SIGN PER 300' OF TREE PROTECTION FENCING SHALL READ: "TREE PROTECTION AREA/DO NOT ENTER AREA/PARA PROTECCION DE LOS ARBOLES/PROHIBIDO ENTRAR".
- MAINTENANCE REQUIREMENTS:**
1. INSPECT WEEKLY, OR INSPECT EVERY 14 DAYS AND AFTER EACH RAINFALL PRODUCING 1/2 INCH OR MORE OF RAIN.
 2. REPAIR OR REPLACE DAMAGED FENCING IMMEDIATELY.
 3. REPLACE ANY DAMAGED SIGNAGE IMMEDIATELY AS NEEDED.
 4. IF ROOTS ARE DAMAGED, CUT OFF DAMAGED AREAS AND PAINT WITH TREE PAINT. SPREAD PEAT MOSS OR MOIST TOPSOIL OVER EXPOSED ROOTS.
 5. REPAIR DAMAGE TO BARK BY TRIMMING AROUND THE DAMAGED AREA, TAPERING CUT TO PROVIDE DRAINAGE. PAINT WITH TREE PAINT.

CONTINUOUS TREE PROTECTION

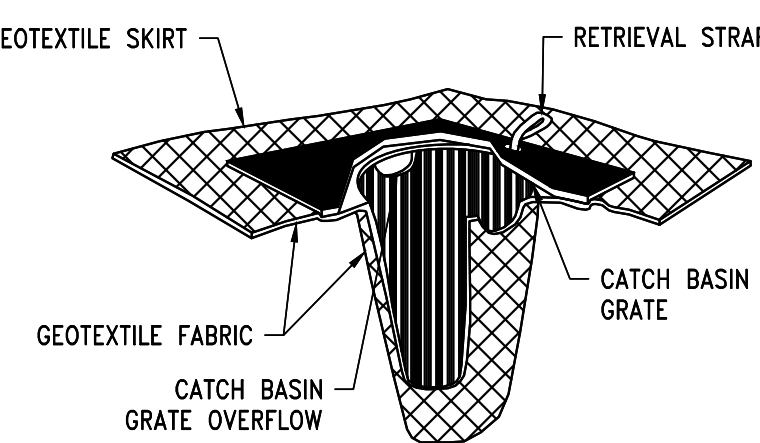

- NOTES:**
1. TO BE INSTALLED IN EXISTING CATCH BASINS WITHIN THE PROJECT LIMITS AS DIRECTED BY THE AUTHORITY.
 2. CONTRACTOR TO VERIFY INLET SIZES PRIOR TO SHOP DRAWING SUBMITTAL.

INLET PROTECTION



Hazen
HAZEN AND SAWYER
24 FEDERAL STREET, 5TH FLOOR
BOSTON, MASSACHUSETTS 02110

REG. PROF. ENGR. _____ DATE _____
RES. PROF. ENGR. _____ DATE _____

NUMBER	DATE	MADE BY	CHECKED BY	DESCRIPTION

MASSACHUSETTS WATER RESOURCES AUTHORITY
DEER ISLAND TREATMENT PLANT
PARKING LOT MODIFICATIONS
STANDARD DETAILS II

CIVIL
MAY 2020

PROJECT NO.	_____
CONTRACT NO.	7645
CAD FILE NO.	7645_TO4_C-007
SHEET NO.	7645_TO4_C-007



ELECTRICAL ABBREVIATIONS

(L/V)CP (LOCAL/VENDOR) CONTROL PANEL
 GND GROUND
 IEEE INSTITUTE OF ELECTRICAL AND ELECTRONICS ENGINEERS
 LTG LIGHTING
 NEMA NATIONAL ELECTRICAL MANUFACTURERS ASSOCIATION
 NFPA NATIONAL FIRE PROTECTION ASSOCIATION
 NTS NOT TO SCALE
 SP. C. SPARE CONDUIT
 TYP TYPICAL

*DESIGNATED ABBREVIATIONS CAN HAVE THE FOLLOWING PREFIXES:
 P POWER

ELECTRICAL LEGEND

LIGHTING:
 POLE-MOUNTED FIXTURE

WIRING:
 CONCRETE ENCASED CONDUIT
 CONDUIT TAGS:
 P DENOTES POWER

GENERAL:
 LIMITS OF DEMOLITION

ELECTRICAL NOTES:

- UNLESS SPECIFICALLY NOTED OTHERWISE, ALL UNDERGROUND CONCRETE ENCASED ELECTRICAL CONDUITS SHALL BE PER STANDARD DETAIL ON THIS SHEET.
- BOND ALL NEW CONCRETE ENCASED GROUND CONDUCTORS TO EXISTING GROUND CONDUCTORS IN ALL MANHOLES, PULL BOXES, CABLE TRAYS, AND SIMILAR LOCATIONS WHERE APPLICABLE.
- A SEPARATE EQUIPMENT GROUNDING CONDUCTOR SHALL BE PROVIDED FOR EACH CIRCUIT (SEPARATE CONDUCTOR IN THE CONDUIT). THE CONDUCTOR SHALL BE TERMINATED AT THE PROPER DEVICE, TERMINAL, OR LUG AT THE POWER SOURCE. GROUND CONDUCTOR SIZE SHALL BE PER THE LATEST EDITION OF THE NEC.
- UNLESS SPECIFICALLY NOTED OTHERWISE, EXISTING PAVEMENT SHALL BE SAW CUT AND REMOVED TO ALLOW FOR THE INSTALLATION OF NEW ELECTRICAL DUCT BANKS AFTER INSTALLATION, REPLACE PAVEMENT WITH NEW TO MATCH ORIGINAL CONDITIONS.

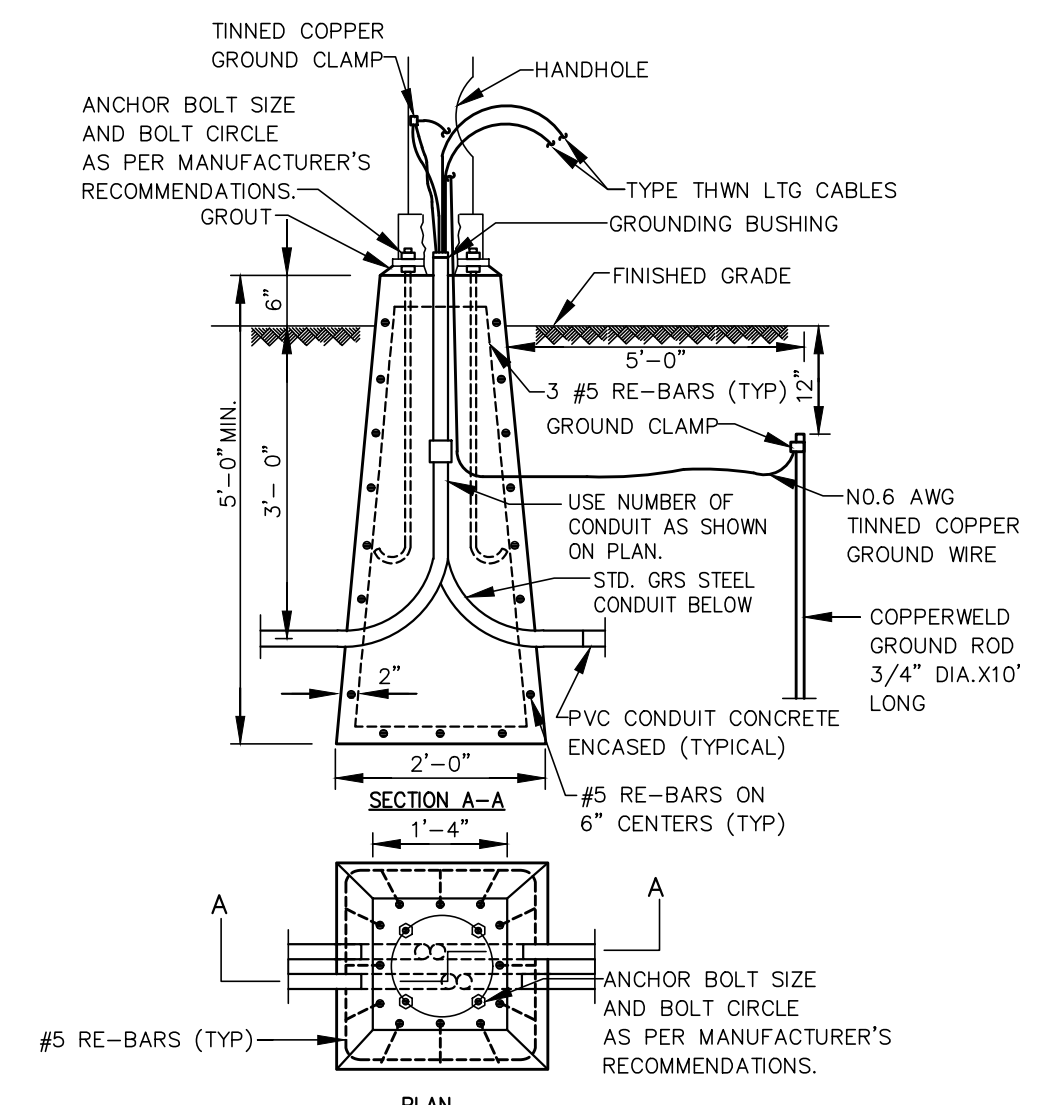

TYPICAL LIGHTING FOUNDATION FOR ROADWAY AND FLOODLIGHTING TO 30'
 N.T.S.

NOTE:
 CIRCUIT GROUND CONDUCTOR AND GROUND ROD, GROUND CONDUCTOR TO BE BONDED TOGETHER AT POLE GROUND CLAMP.



Hazen
 HAZEN AND SAWYER
 24 FEDERAL STREET, 5TH FLOOR
 BOSTON, MASSACHUSETTS 02110

REG. PROF. ENGR. _____ DATE _____
 REG. PROF. ENGR. _____ DATE _____

SCALE: AS SHOWN
UNLESS OTHERWISE NOTED OR CHANGED BY REVISION

DESIGNED BY: DAW					
DRAWN BY: KTR					
CHECKED BY: DAW					
APPROVED BY: DAW					

NUMBER	DATE	MADE BY	CHECKED BY	DESCRIPTION

MASSACHUSETTS WATER RESOURCES AUTHORITY
 DEER ISLAND TREATMENT PLANT

PARKING LOT MODIFICATIONS
 ELECTRICAL LEGEND, ABBREVIATIONS,
 NOTES, AND DETAILS



PROJECT NO.	_____
CONTRACT NO.	7645
CAD FILE NO.	7645_T04_E-001
SHEET NO.	7645_T04_E-001

NOTES:

1. REMOVE EXISTING BRANCH CIRCUIT CONDUCTORS. SAVE UNDERGROUND CONDUITS FOR REUSE.
2. DISCONNECT AND REMOVE EXISTING LIGHT POLE AND SAVE FOR REUSE. REMOVE POLE BASE. EXPOSE EXISTING CONDUIT AND SAVE FOR REUSE.

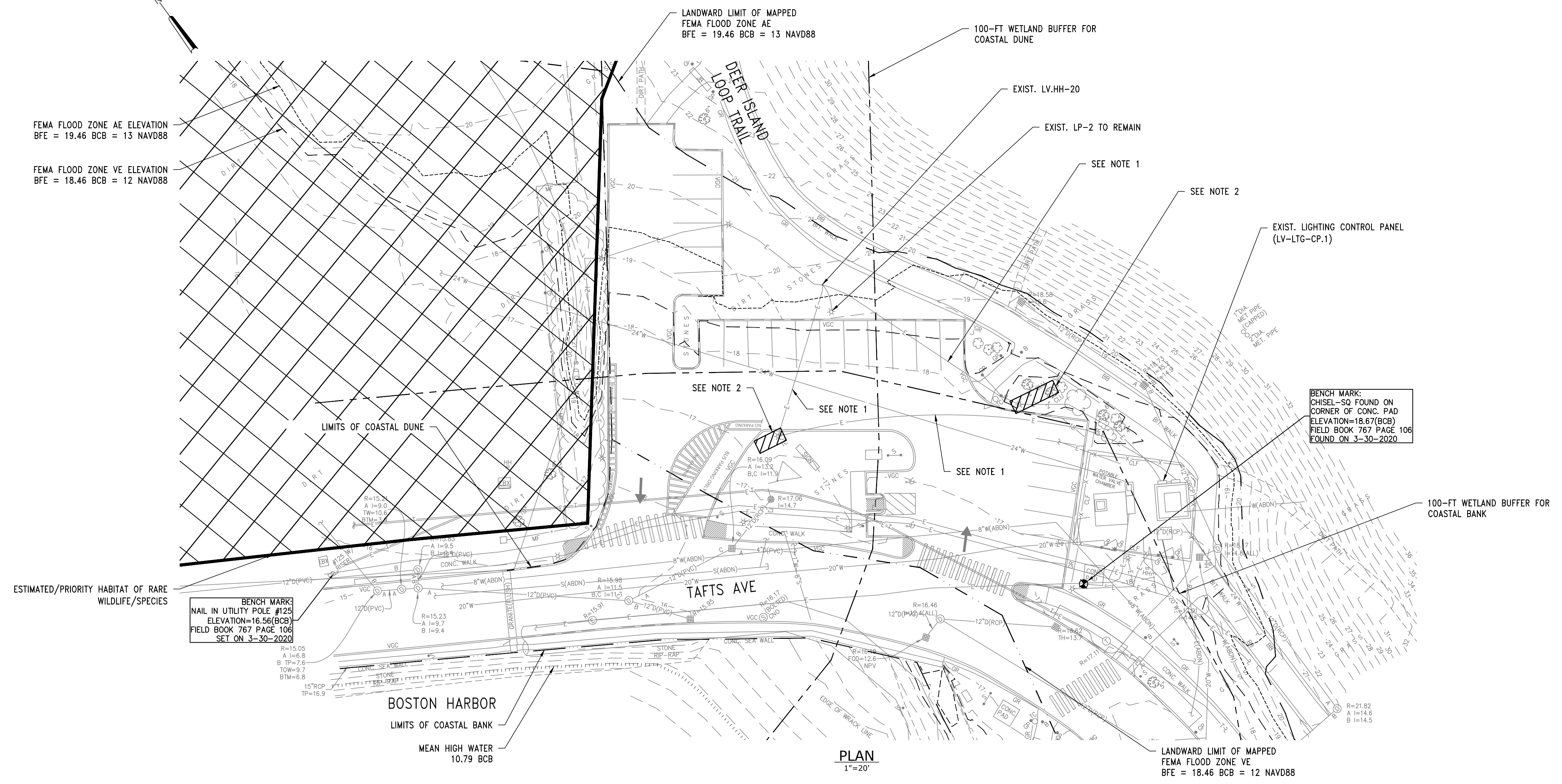

PLAN
1"=20'

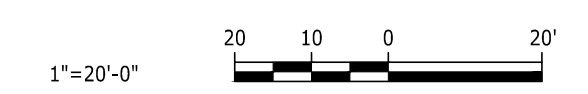

Hazen
HAZEN AND SAWYER
24 FEDERAL STREET, 5TH FLOOR
BOSTON, MASSACHUSETTS 02110

REG. PROF. ENGR. _____ DATE _____
REG. PROF. ENGR. _____ DATE _____

SCALE: AS SHOWN
UNLESS OTHERWISE NOTED OR
CHANGED BY REVISION

DESIGNED BY: DAW
DRAWN BY: KTR
CHECKED BY: DAW
APPROVED BY: DAW

NUMBER	DATE	MADE BY	CHECKED BY	REVISIONS	DESCRIPTION

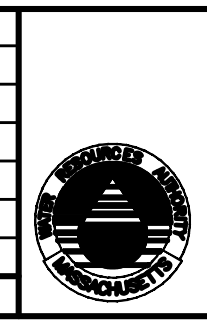

MASSACHUSETTS WATER RESOURCES AUTHORITY
DEER ISLAND TREATMENT PLANT
PARKING LOT MODIFICATIONS
ELECTRICAL DEMOLITION

PROJECT NO. _____
CONTRACT NO. 7645
CAD FILE NO. 7645_T04_E-002
SHEET NO. 7645_T04_E-002

NOTES:

1. EXCAVATE AS REQUIRED TO NEW POLE BASE LOCATION. EXTEND EXISTING CONCRETE ENCASED DUCT BANK WITH 2-1" PVC CONDUITS TO NEW POLE BASE LOCATION. PROVIDE NEW POLE BASE PER DETAIL SHOWN ON SHEET E-01.
2. FURNISH AND INSTALL 4#10, #10 GND BETWEEN LIGHTING CONTROL PANEL LV-LTG-CP-1 AND LP-1.
3. FURNISH AND INSTALL 4#10, #10 GND BETWEEN LP-1 AND LP-2.
4. FURNISH AND INSTALL 4#10, #10 GND BETWEEN LP-2 AND LP-3.

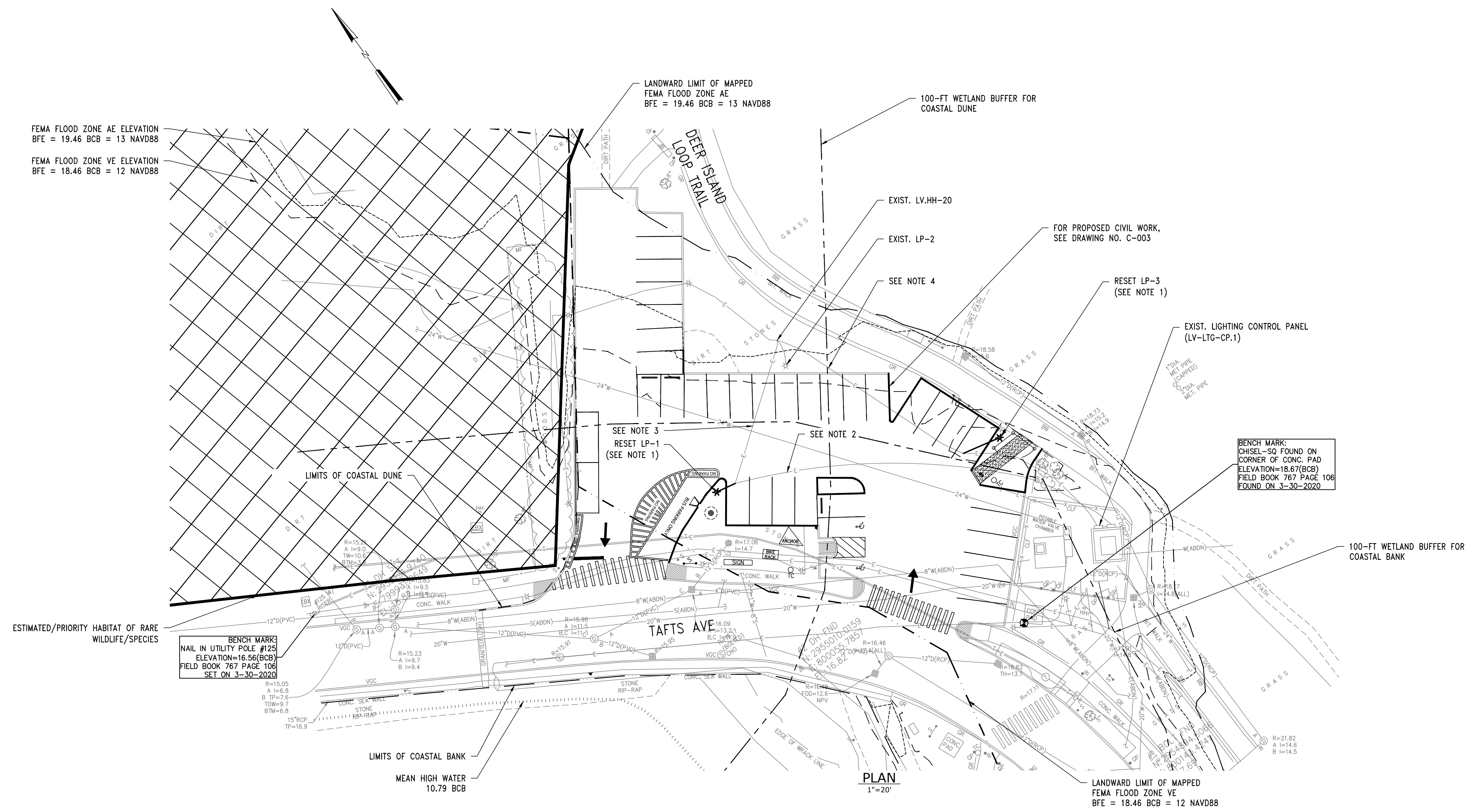

PLAN
1"=20'

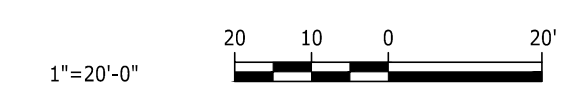

Hazen
HAZEN AND SAWYER
24 FEDERAL STREET, 5TH FLOOR
BOSTON, MASSACHUSETTS 02110

SCALE: AS SHOWN
UNLESS OTHERWISE NOTED OR
CHANGED BY REVISION

DESIGNED BY:	DAW	NUMBER	DATE	MADE BY	CHECKED BY	REVISIONS	DESCRIPTION
DRAWN BY:	KTR						
CHECKED BY:	DAW						
APPROVED BY:	DAW						

MASSACHUSETTS WATER RESOURCES AUTHORITY
DEER ISLAND TREATMENT PLANT
PARKING LOT MODIFICATIONS
ELECTRICAL NEW WORK

PROJECT NO. _____
CONTRACT NO. 7645
CAD FILE NO. 7645_T04_E-003
SHEET NO. 7645_T04_E-003

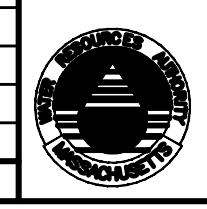

Appendix D

Operation and Maintenance Plan

**Deer Island Treatment Plant Parking Lot Modifications
Stormwater Management System**

**Operation and Maintenance Plan (O&M)
and
Long Term Pollution Prevention Plan (LTPPP)**

June 2020

The following Operation and Maintenance Plan provides the requirements for inspection and maintenance of the Best Management Practice installed at the Deer Island parking lot along with a long term pollution prevention plan to improve the water quality of stormwater runoff at the site.

Proposed Project

The proposed stormwater management improvement consists of a leaching catch basin. The leaching catch basin is located downstream of the parking lot drainage area, and it's sized to exceed the required recharge volume for the new impervious surfaces. The leaching catch basin also provides pretreatment since it is designed to be off-line and located within a stone median. This BMP does not generate any new discharges to receiving waters.

Responsible Party

The Massachusetts Water Resources Authority (MWRA) will be responsible for the maintenance of the leaching catch basin. Questions or concerns regarding maintenance activities may be directed to MWRA at the following address:

MWRA
Charlestown Navy Yard
100 First Ave, Building 39
Boston, MA 02129

Maintenance Measures

Maintenance of the leaching catch basin will be conducted as indicated in the schedule below. If inspection indicates the need for major repairs, the inspector should contact MWRA to initiate procedure to effect repairs.

Table 1 Leaching Catch Basin Maintenance Schedule

Activity	Frequency
Inspect leaching catch basin	Annually or more frequently as indicated by structure performance
Remove debris	As needed based on inspections
Remove sediments	When the basin is 50% filled
Repair/Rehabilitate basin if it fails due to clogging	As needed based on inspections

Practices for Long Term Pollution Prevention

Long term pollution prevention includes the following measures:

Litter Pick-up

MWRA will conduct litter pick-up from the stormwater management practice in conjunction with routine parking lot maintenance activities.

Routine Inspection and Maintenance of Stormwater BMP

MWRA will conduct inspection and maintenance of the stormwater management practice in accordance with the guidelines discussed above.

Snow and Ice Management

Snow and Ice Management shall be conducted consistent with the practices outlined by the City.

Prohibition of Illicit Discharges

The MassDEP Stormwater Management Standards prohibit illicit discharges to the storm water management system. Illicit discharges are discharges that do not entirely consist of stormwater, except for certain specified non-stormwater discharges.

Examples of discharges from the following sources are not considered illicit discharges:
Water from firefighting activities is allowed under this permit and need only be addressed where they are identified as significant sources of pollutants to waters of the United States.

- | | |
|----------------------------|--|
| Firefighting activities | Riparian habitats/wetlands |
| Foundation drains | Potable water sources |
| Water line flushing | Dechlorinated swimming pool water |
| Footing drains | Landscape irrigation systems |
| Residential car washing | Wash water for street and buildings (without detergents) |
| Uncontaminated groundwater | Condensation from air conditioning units |

There are no known or proposed illicit connections associated with this project. If a potential illicit discharge to the parking lot covered by this plan is detected (e.g., evidence of contamination of surface water discharge by non-stormwater sources), MWRA shall be notified for assistance in determining the nature and source of the discharge.

**ATTACHMENT 7
LIST OF ABUTTERS**

**Massachusetts Water Resources Authority
Deer Island Treatment Plant
Parking Lot Modifications
Boston, MA**

**Massachusetts Water Resources Authority
Deer Island Parking Lot Modification
Boston, MA
List of Abutters within 300 feet of the Proposed Project**

Abutting Property Address	Owner Name	Listed Owner Address
1 Tafts Avenue/154 Adams Street, Winthrop MA 02152	Norton Michael Owen	5 Fremont Street, Winthrop, MA 02152
Tafts Avenue, Boston MA 02152	Norton Michael Owen	65 Telegraph Street, South Boston, MA 02127



Hazen and Sawyer
498 Seventh Avenue, 11th Floor
New York, NY 10018 • 212.539.7000

July 2, 2020

Norton Michael Owen
5 Fremont Street
Winthrop, MA 02152

Re: Notice of Intent Abutter Notification

Dear Mr. Owen:

In accordance with the Massachusetts Wetlands Protection Act, Massachusetts General Laws Chapter 131, Section 40, and the Boston Wetlands Ordinance, you are hereby notified as an abutter to a project filed with the Boston Conservation Commission.

The Massachusetts Water Resources Authority (MWRA) has filed a Notice of Intent with the Boston Conservation Commission seeking permission to alter an Area Subject to Protection under the Wetlands Protection Act (General Laws Chapter 131, section 40) and Boston Wetlands Ordinance.

The address of the lot where the activity is proposed is at Tafts Avenue on Deer Island, Boston, MA.

The project involves the reconfiguration of an existing parking lot to add 11 new parking spaces to provide visitor parking for Deer Island Public Access Area. One existing parking space would be removed to allow the relocation of an existing sidewalk providing access from the parking lot to the public walkway. A leaching catch basin would be installed onsite to control stormwater runoff from the parking lot. In addition, the parking lot will be milled and repaved with asphalt.

Copies of the Notice of Intent may be obtained by contacting the Boston Conservation Commission at CC@boston.gov.

Copies of the Notice of Intent may be obtained from Hazen and Sawyer at jbuckley@hazenandsawyer.com between the hours of 9 AM to 5 PM, Monday through Friday.

In accordance with the Commonwealth of Massachusetts Executive Order Suspending Certain Provisions of the Open Meeting Law, the public hearing will take place virtually at <https://zoom.us/j/6864582044>. If you are unable to access the internet, you can call 1-929-205-6099, enter Meeting ID 686 458 2044 # and use # as your participant ID.

Information regarding the date and time of the public hearing may be obtained from the Boston Conservation Commission by emailing CC@boston.gov or calling (617) 635-3850 between the hours of 9 AM to 5 PM, Monday through Friday.

Notice of the public hearing, including its date, time, and place, will be published at least five (5) days in advance in the Boston Herald.

Job no

Notice of the public hearing, including its date, time, and place, will be posted on www.boston.gov/public-notices and in Boston City Hall not less than forty-eight (48) hours in advance.

If you would like to provide comments, you may attend the public hearing or send written comments to CC@boston.gov or Boston City Hall, Environment Department, Room 709, 1 City Hall Square, Boston, MA 02201.

You also may contact the Boston Conservation Commission or the Department of Environmental Protection Northeast Regional Office for more information about this application or the Wetlands Protection Act. To contact DEP, call: the Northeast Region: (978) 694-3200.

Very truly yours,

A handwritten signature in blue ink, appearing to be 'JB', with a stylized flourish extending to the right.

Joseph Buckley, PWS
Associate

cc: MWRA: R. Adams
Hazen: A. Angles, B. Levin



Hazen and Sawyer
498 Seventh Avenue, 11th Floor
New York, NY 10018 • 212.539.7000

July 2, 2020

Norton Michael Owen
65 Telegraph St.
South Boston, MA 02127

Re: Notice of Intent Abutter Notification

Dear Mr. Owen:

In accordance with the Massachusetts Wetlands Protection Act, Massachusetts General Laws Chapter 131, Section 40, and the Boston Wetlands Ordinance, you are hereby notified as an abutter to a project filed with the Boston Conservation Commission.

The Massachusetts Water Resources Authority (MWRA) has filed a Notice of Intent with the Boston Conservation Commission seeking permission to alter an Area Subject to Protection under the Wetlands Protection Act (General Laws Chapter 131, section 40) and Boston Wetlands Ordinance.

The address of the lot where the activity is proposed is at Tafts Avenue on Deer Island, Boston, MA.

The project involves the reconfiguration of an existing parking lot to add 11 new parking spaces to provide visitor parking for Deer Island Public Access Area. One existing parking space would be removed to allow the relocation of an existing sidewalk providing access from the parking lot to the public walkway. A leaching catch basin would be installed onsite to control stormwater runoff from the parking lot. In addition, the parking lot will be milled and repaved with asphalt.

Copies of the Notice of Intent may be obtained by contacting the Boston Conservation Commission at CC@boston.gov.

Copies of the Notice of Intent may be obtained from Hazen and Sawyer at jbuckley@hazenandsawyer.com between the hours of 9 AM to 5 PM, Monday through Friday.

In accordance with the Commonwealth of Massachusetts Executive Order Suspending Certain Provisions of the Open Meeting Law, the public hearing will take place virtually at <https://zoom.us/j/6864582044>. If you are unable to access the internet, you can call 1-929-205-6099, enter Meeting ID 686 458 2044 # and use # as your participant ID.

Information regarding the date and time of the public hearing may be obtained from the Boston Conservation Commission by emailing CC@boston.gov or calling (617) 635-3850 between the hours of 9 AM to 5 PM, Monday through Friday.

Notice of the public hearing, including its date, time, and place, will be published at least five (5) days in advance in the Boston Herald.

Job no

Notice of the public hearing, including its date, time, and place, will be posted on www.boston.gov/public-notices and in Boston City Hall not less than forty-eight (48) hours in advance.

If you would like to provide comments, you may attend the public hearing or send written comments to CC@boston.gov or Boston City Hall, Environment Department, Room 709, 1 City Hall Square, Boston, MA 02201.

You also may contact the Boston Conservation Commission or the Department of Environmental Protection Northeast Regional Office for more information about this application or the Wetlands Protection Act. To contact DEP, call: the Northeast Region: (978) 694-3200.

Very truly yours,



Joseph Buckley, PWS
Associate

cc: MWRA: R. Adams
Hazen: A. Angles, B. Levin

7018 1130 0000 3876 5945

U.S. Postal Service™
CERTIFIED MAIL® RECEIPT
Domestic Mail Only

For delivery information, visit our website at www.usps.com®.

WINTHROP, MA 02152

Certified Mail Fee	\$3.55
\$	\$2.85
Extra Services & Fees (check box, add fee as appropriate)	\$0.00
<input type="checkbox"/> Return Receipt (hardcopy)	\$0.00
<input type="checkbox"/> Return Receipt (electronic)	\$0.00
<input type="checkbox"/> Certified Mail Restricted Delivery	\$0.00
<input type="checkbox"/> Adult Signature Required	\$0.00
<input type="checkbox"/> Adult Signature Restricted Delivery	\$0.00
Postage	\$0.55
\$	
Total Postage and Fees	\$6.95
\$	

OFFICIAL USE

07/02/2020

Sent To Norton Michael Owen
 Street and Apt. No., or PO Box No. 5 Fremont St.
 City, State, ZIP+4® Winthrop MA 02152

PS Form 3800, April 2015 PSN 7530-02-000-9047 See Reverse for Instructions

7018 1130 0000 3876 5952

U.S. Postal Service™
CERTIFIED MAIL® RECEIPT
Domestic Mail Only

For delivery information, visit our website at www.usps.com®.

SOUTH BOSTON, MA 02127

Certified Mail Fee	\$3.55
\$	\$2.85
Extra Services & Fees (check box, add fee as appropriate)	\$0.00
<input type="checkbox"/> Return Receipt (hardcopy)	\$0.00
<input type="checkbox"/> Return Receipt (electronic)	\$0.00
<input type="checkbox"/> Certified Mail Restricted Delivery	\$0.00
<input type="checkbox"/> Adult Signature Required	\$0.00
<input type="checkbox"/> Adult Signature Restricted Delivery	\$0.00
Postage	\$0.55
\$	
Total Postage and Fees	\$6.95
\$	

OFFICIAL USE

07/02/2020

Sent To Norton Michael Owen
 Street and Apt. No., or PO Box No. 65 Telegraph St.
 City, State, ZIP+4® South Boston, MA 02127

PS Form 3800, April 2015 PSN 7530-02-000-9047 See Reverse for Instructions