

# 25 CLAREMONT

BOSTON, MA 02118

**SEDC**

1 / 22 / 2020

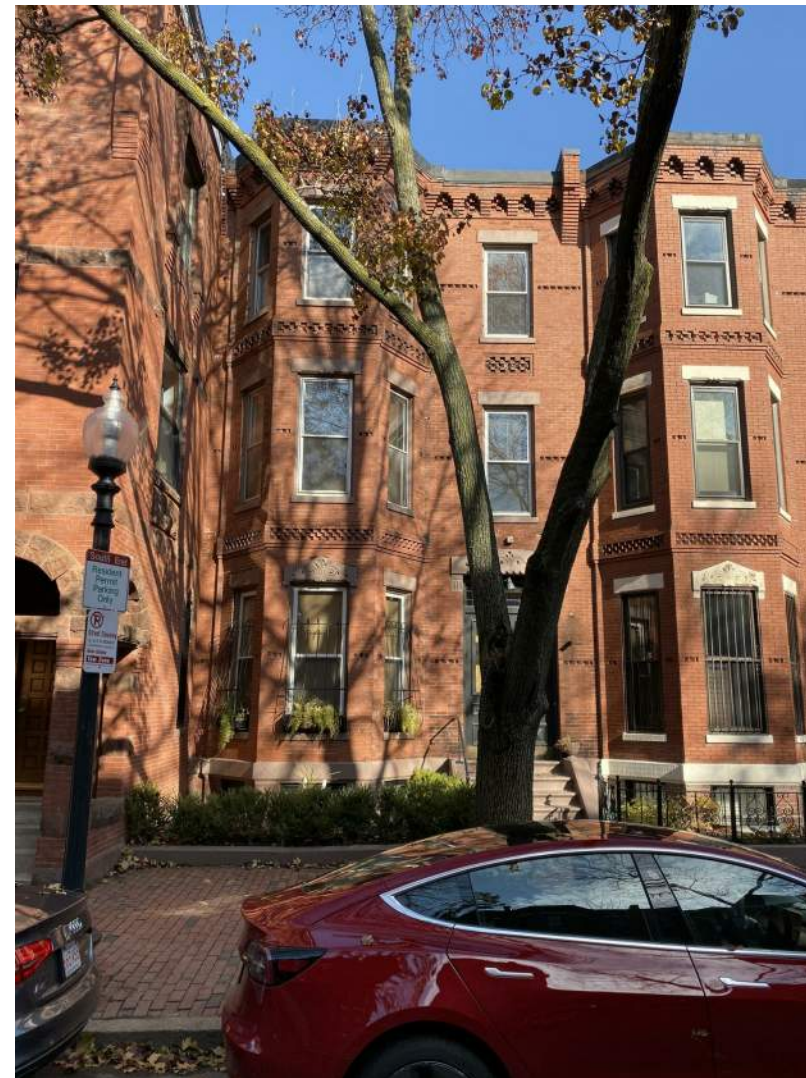

EMBARC



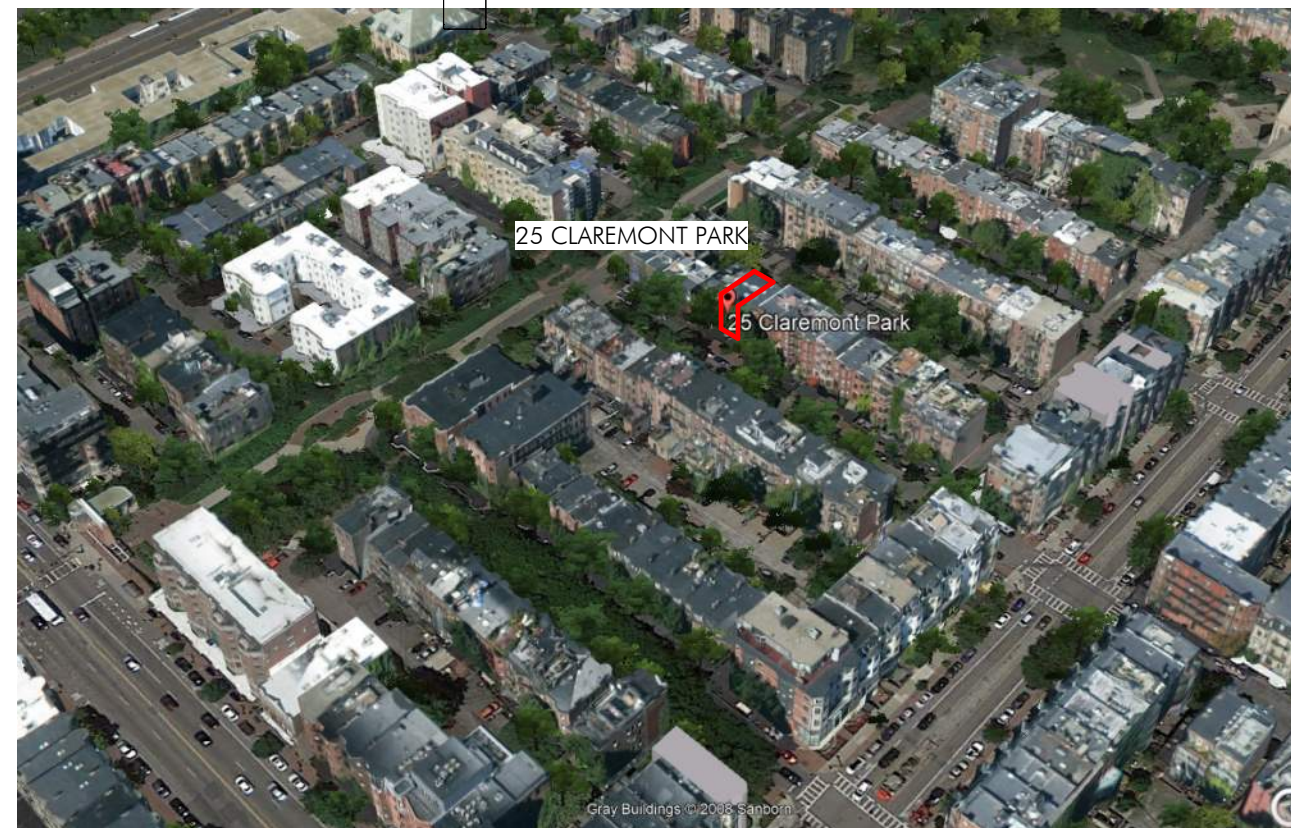
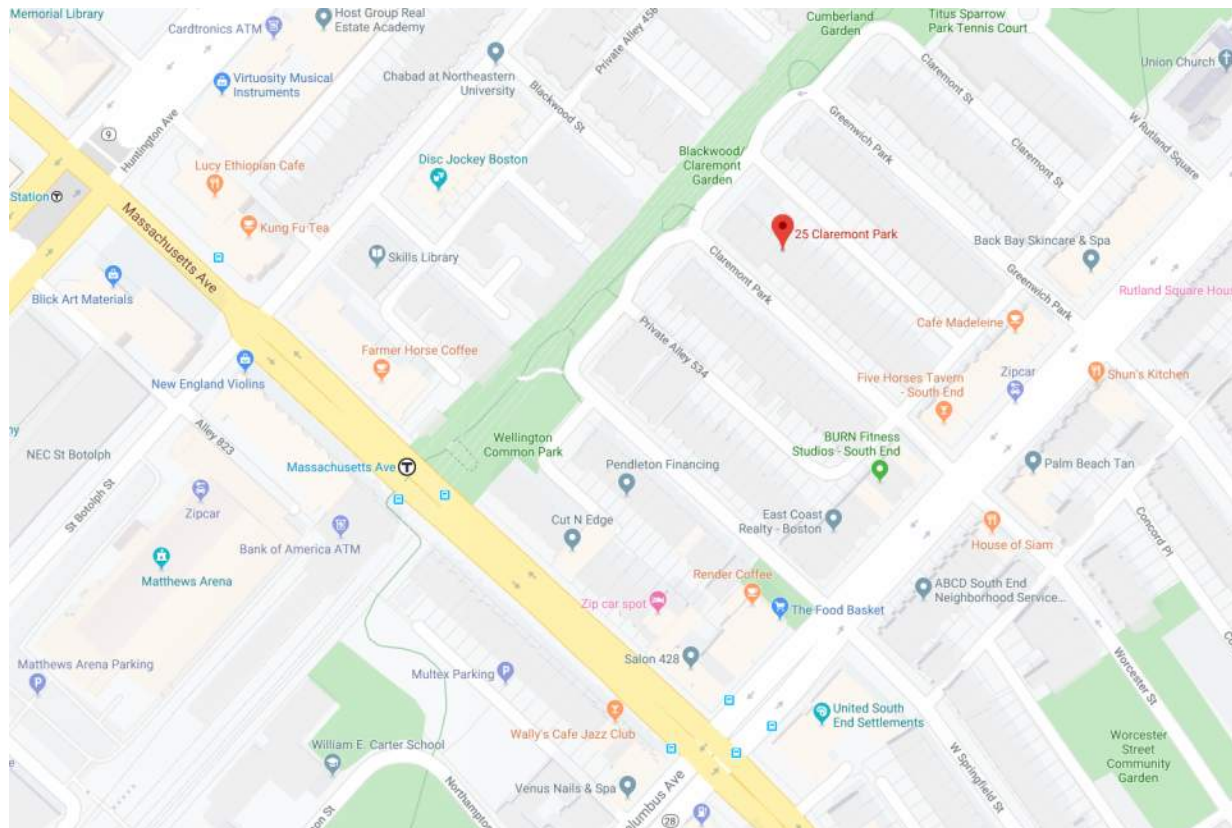
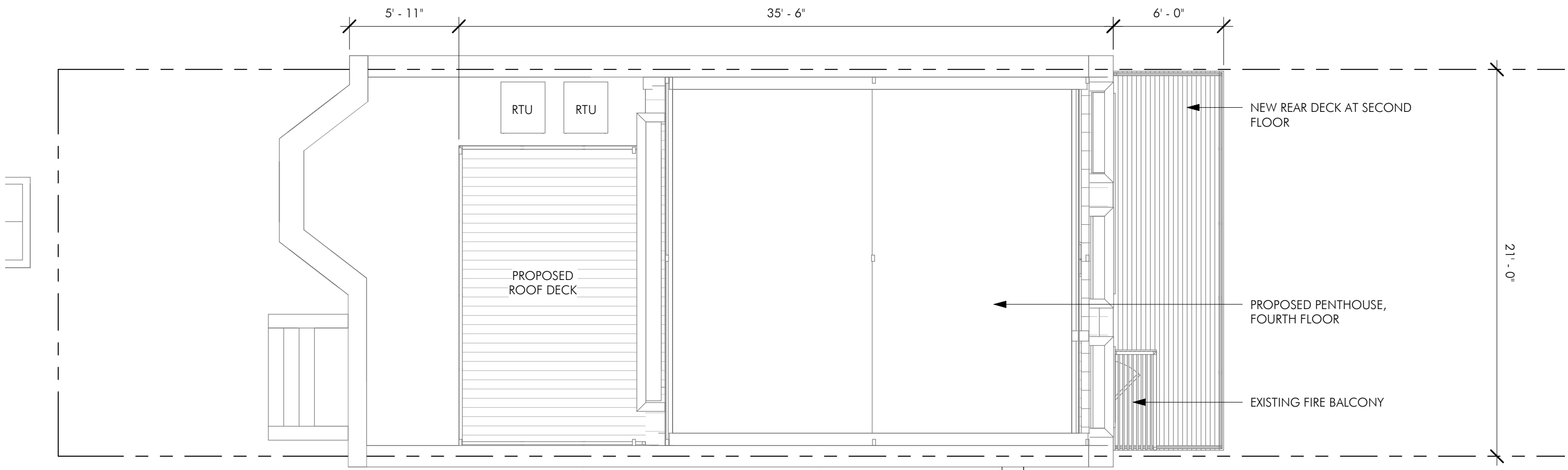



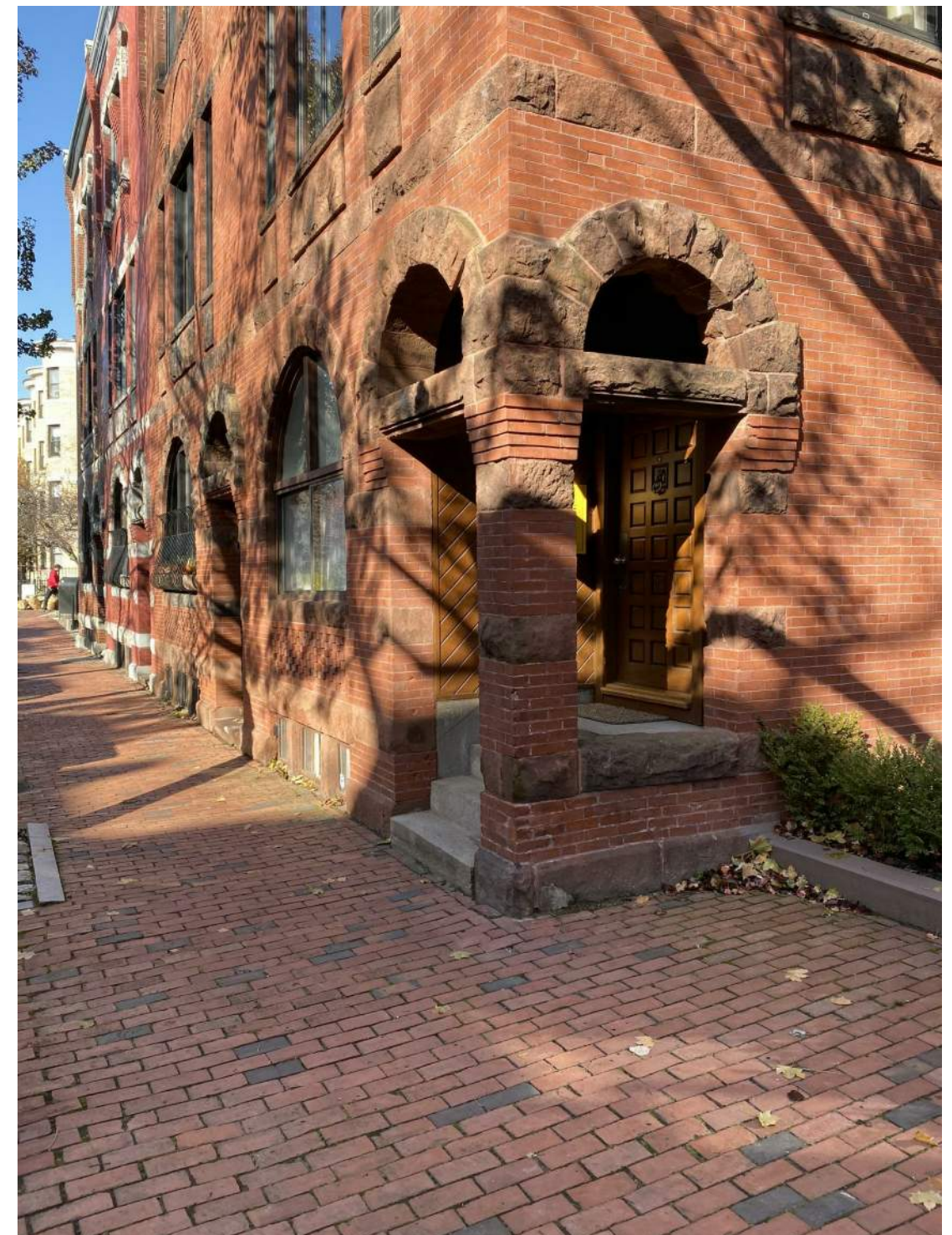







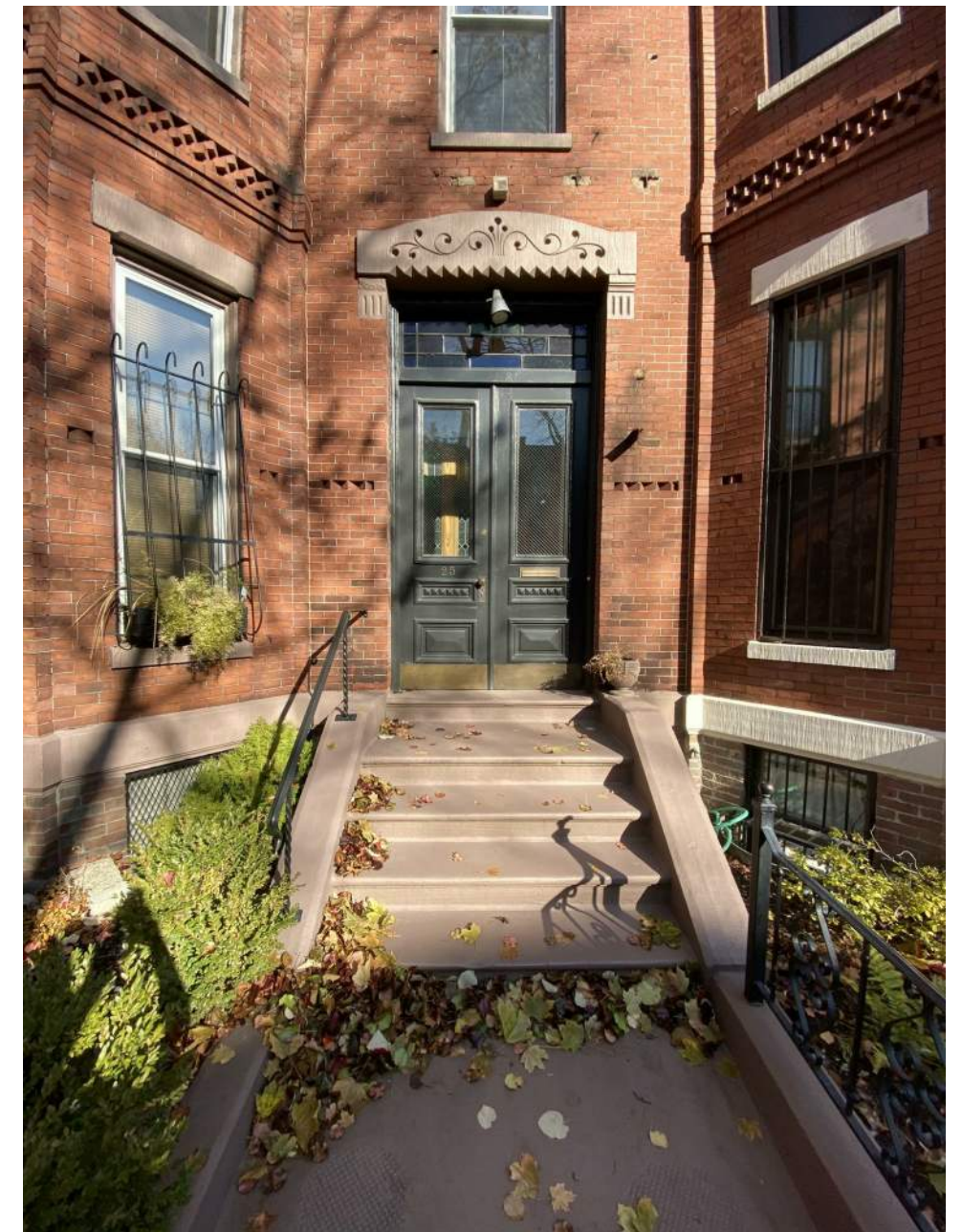
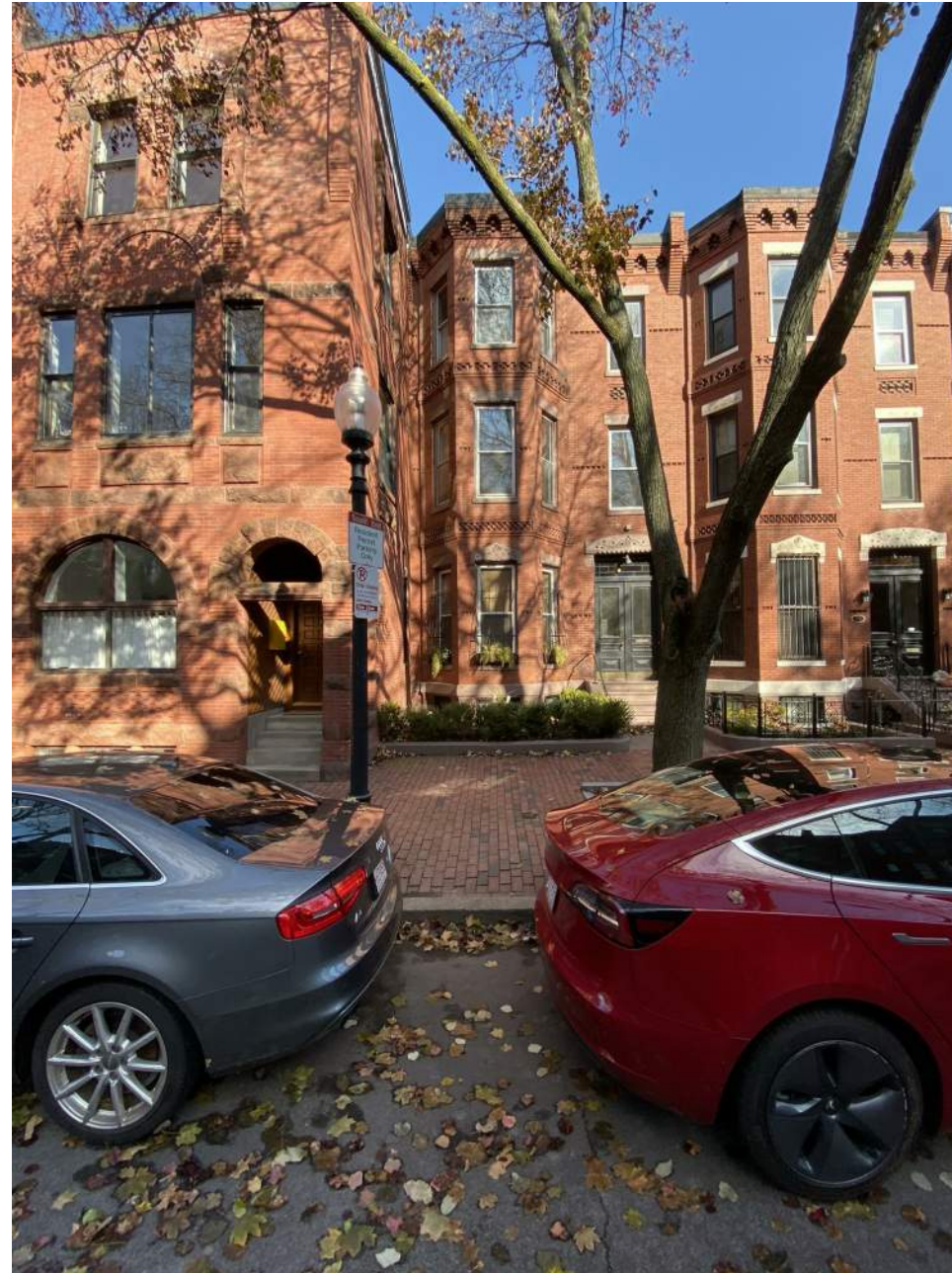
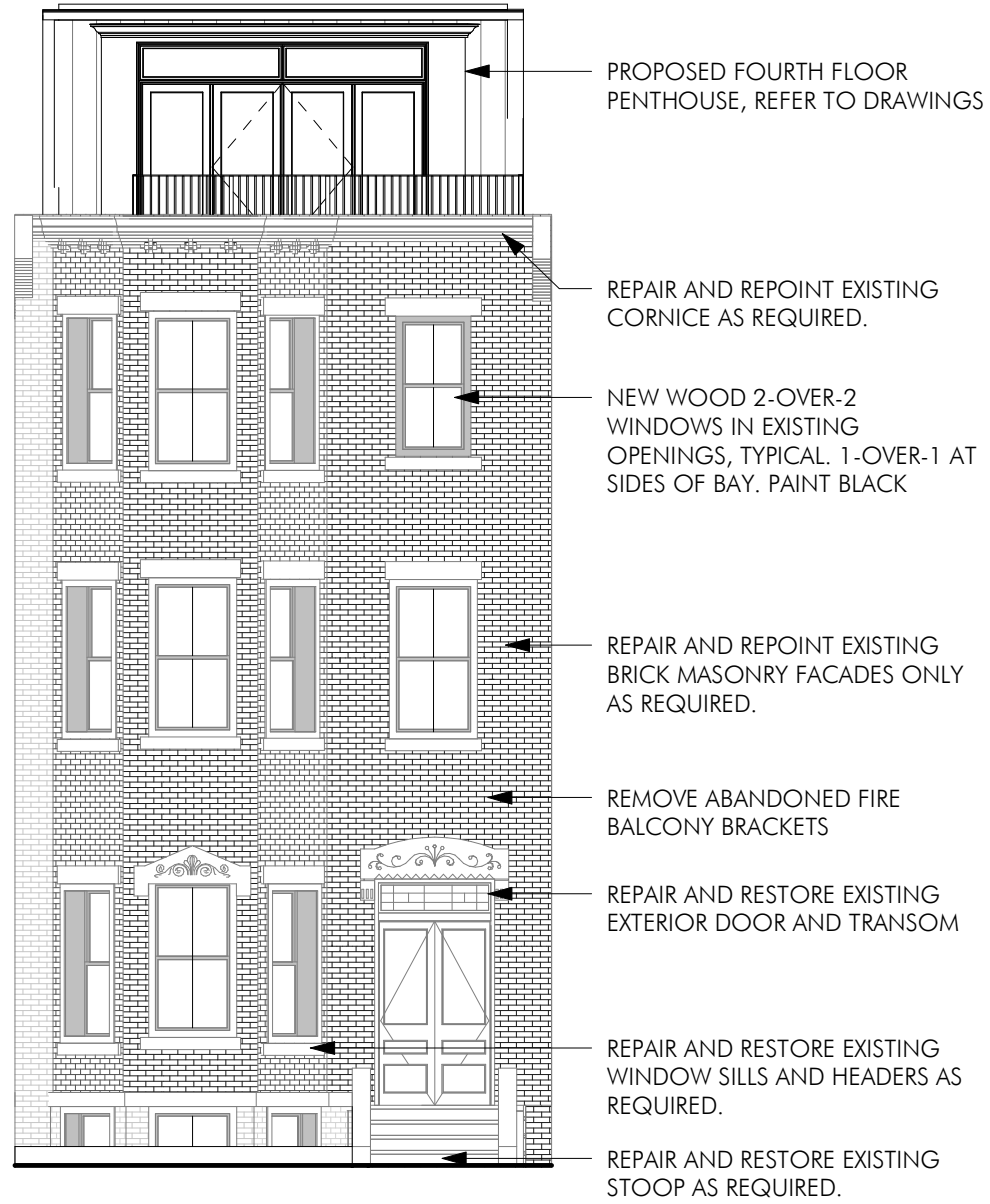

1 LANDMARKS- FRONT ELEVATION  
1/8" = 1'-0"







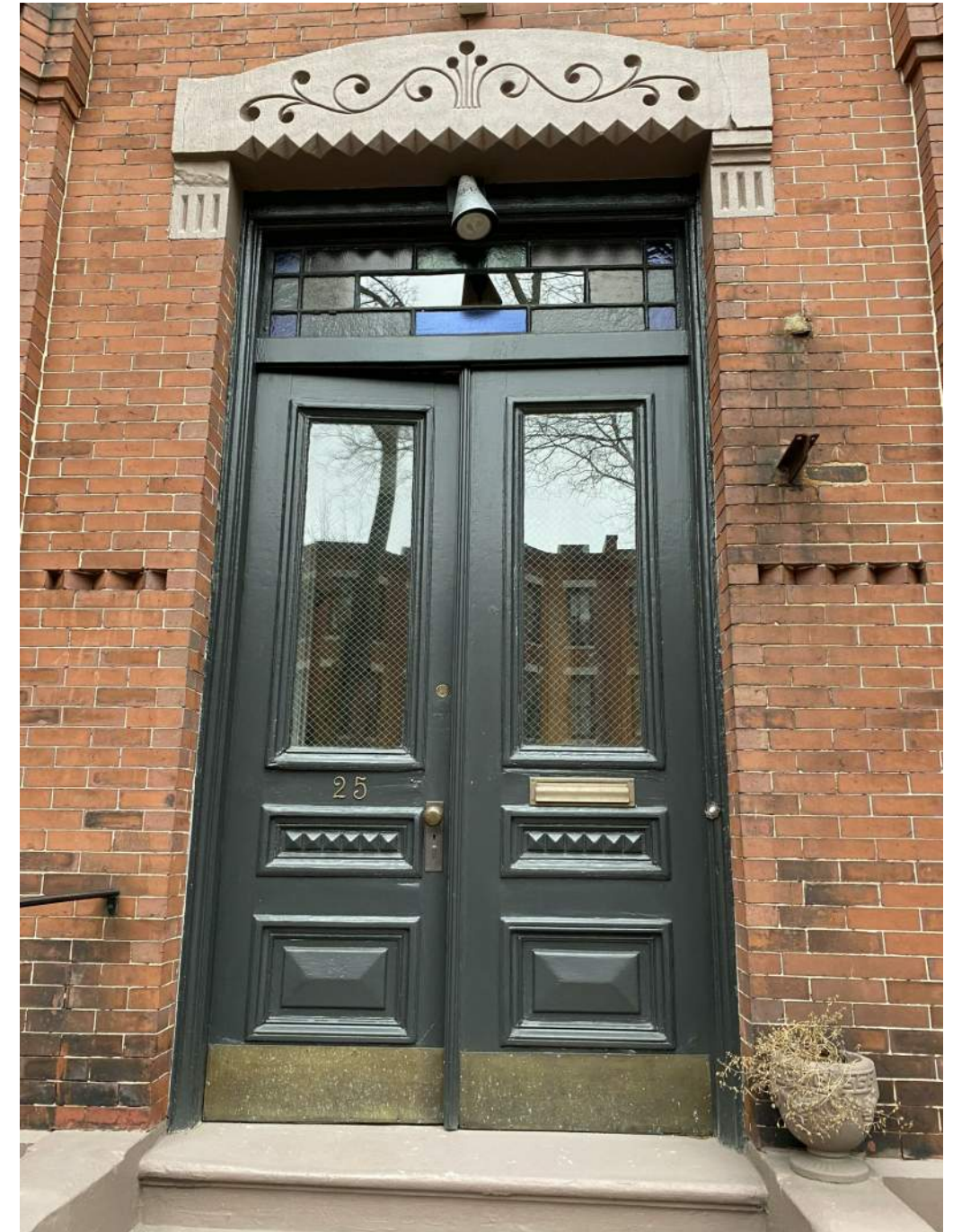



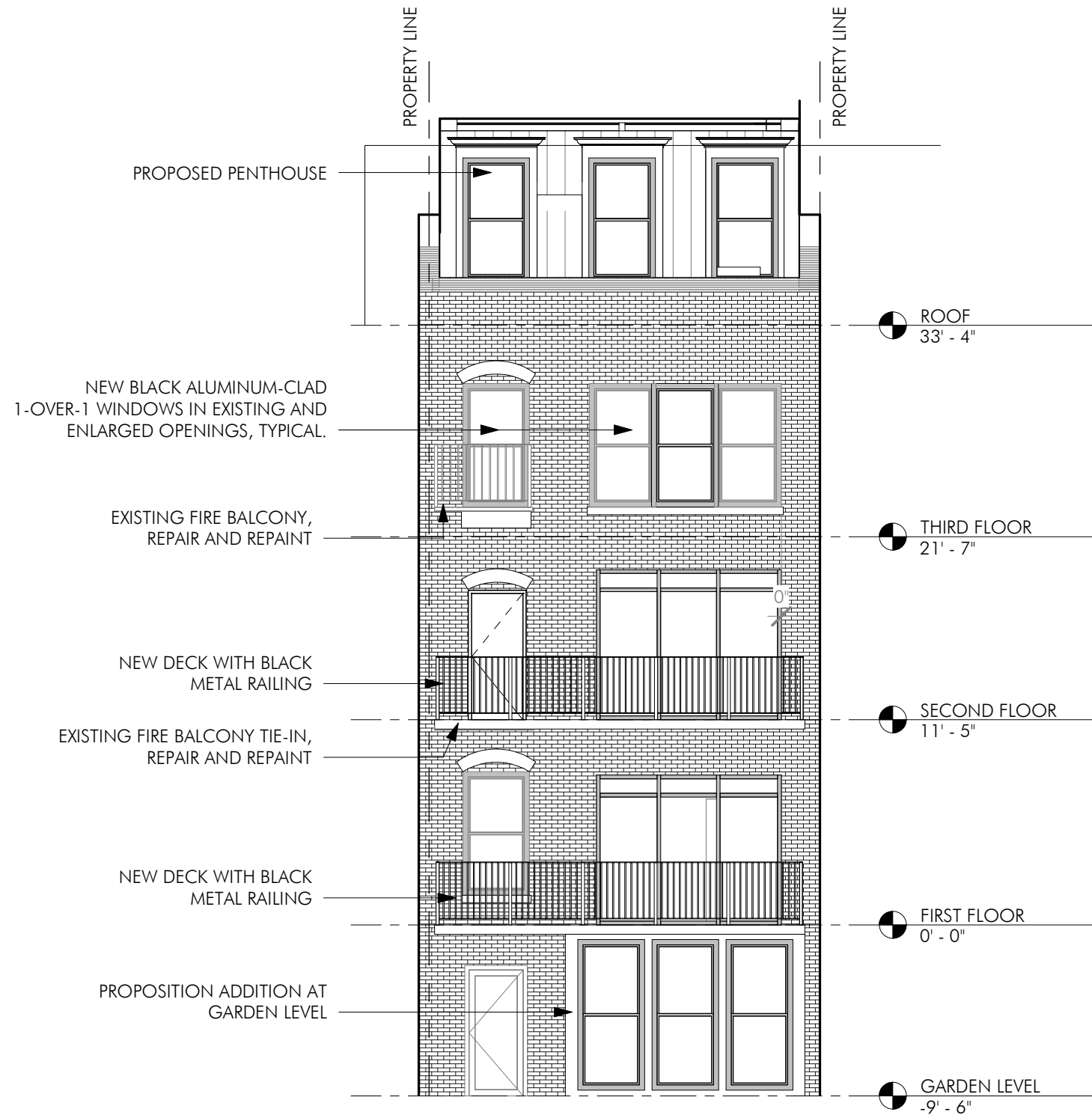

1 LANDMARKS - REAR ELEVATION  
1/8" = 1'-0"





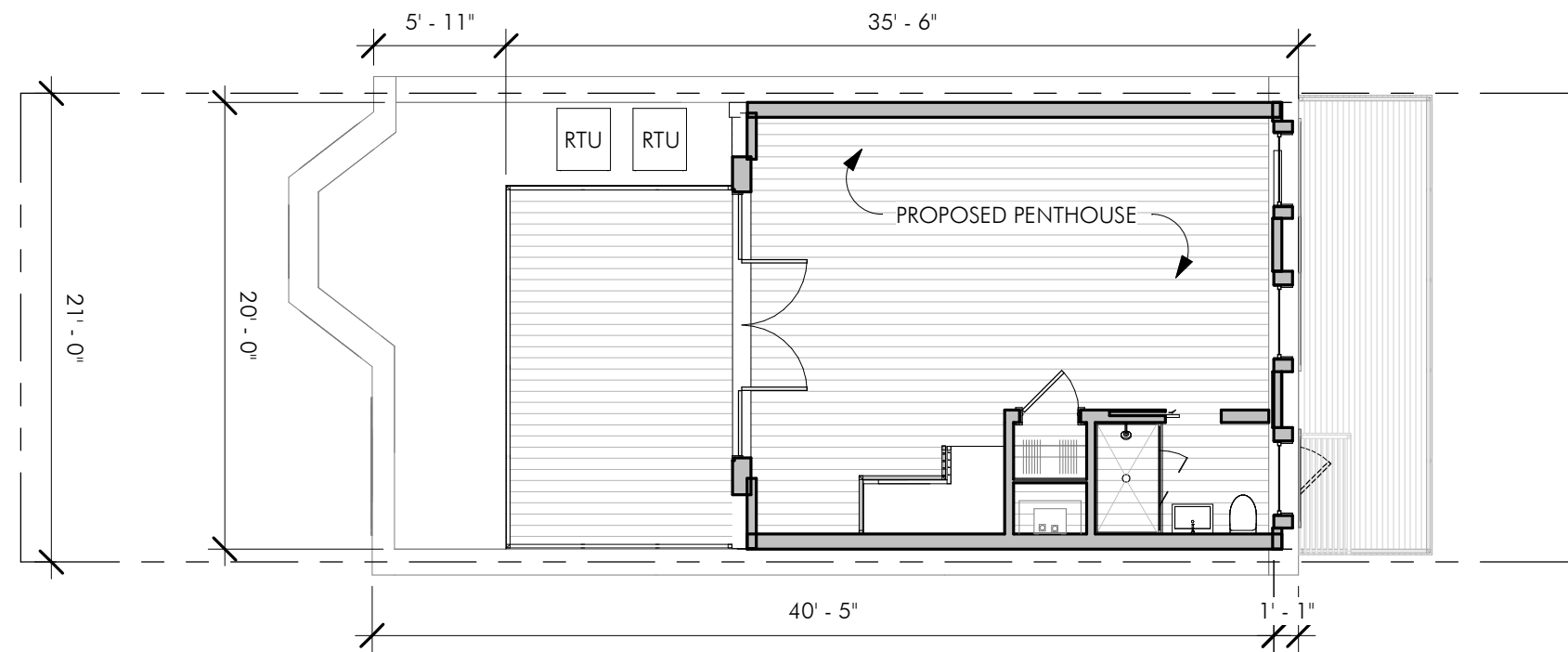
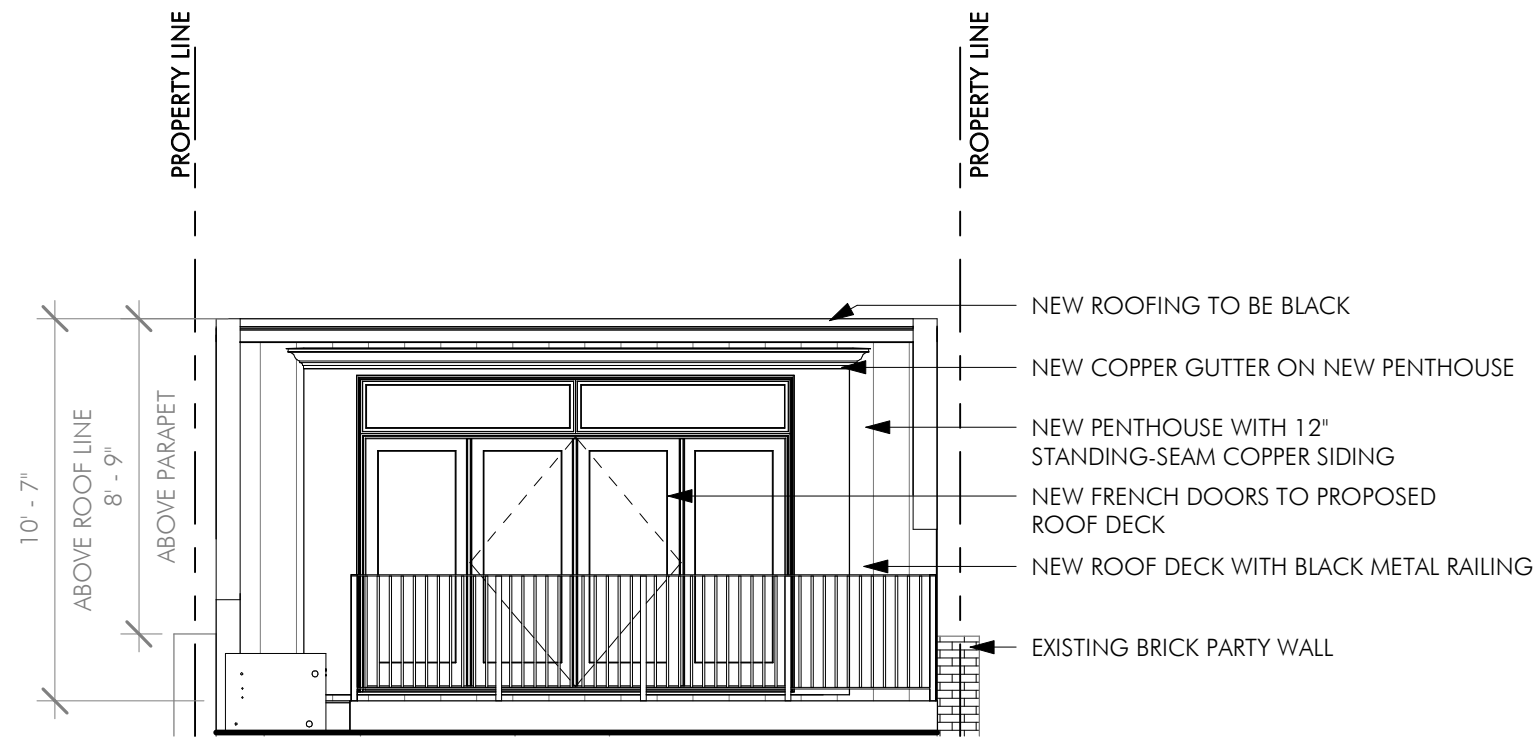



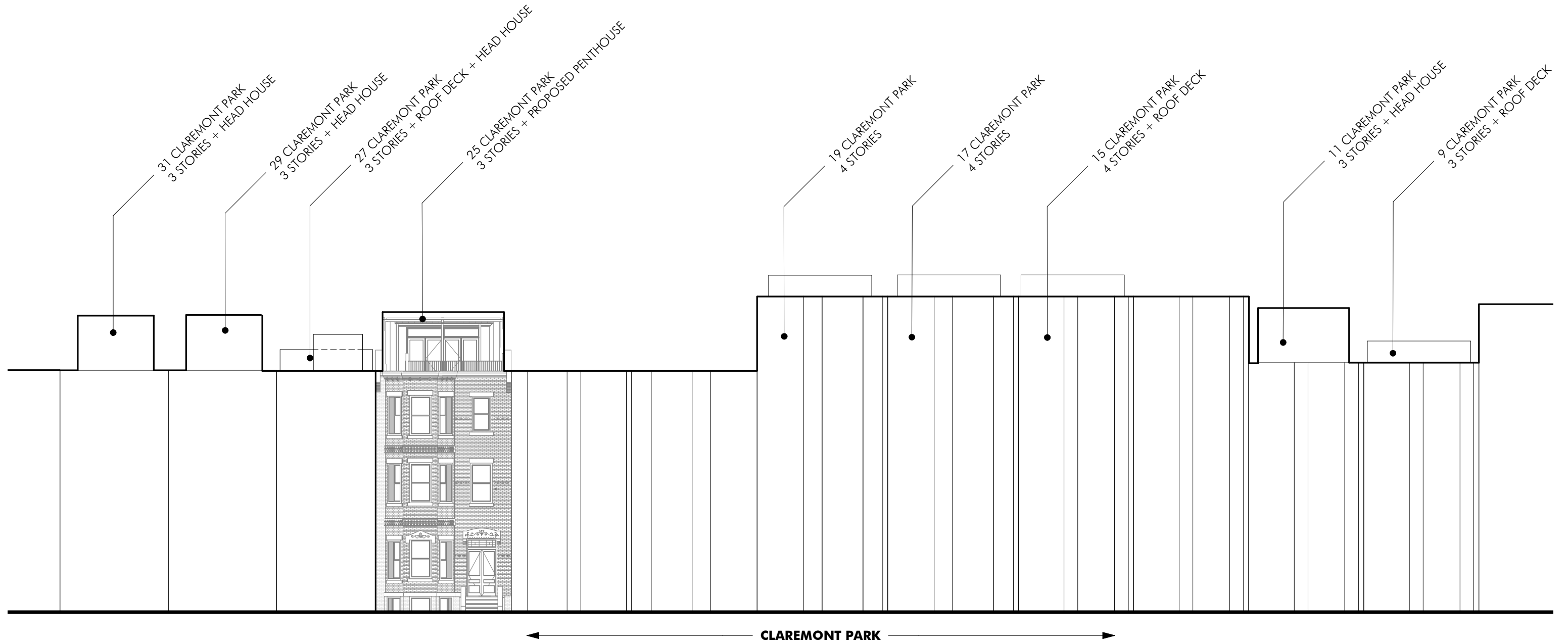



PROPERTY LINE

PROPERTY LINE

PROPERTY LINE

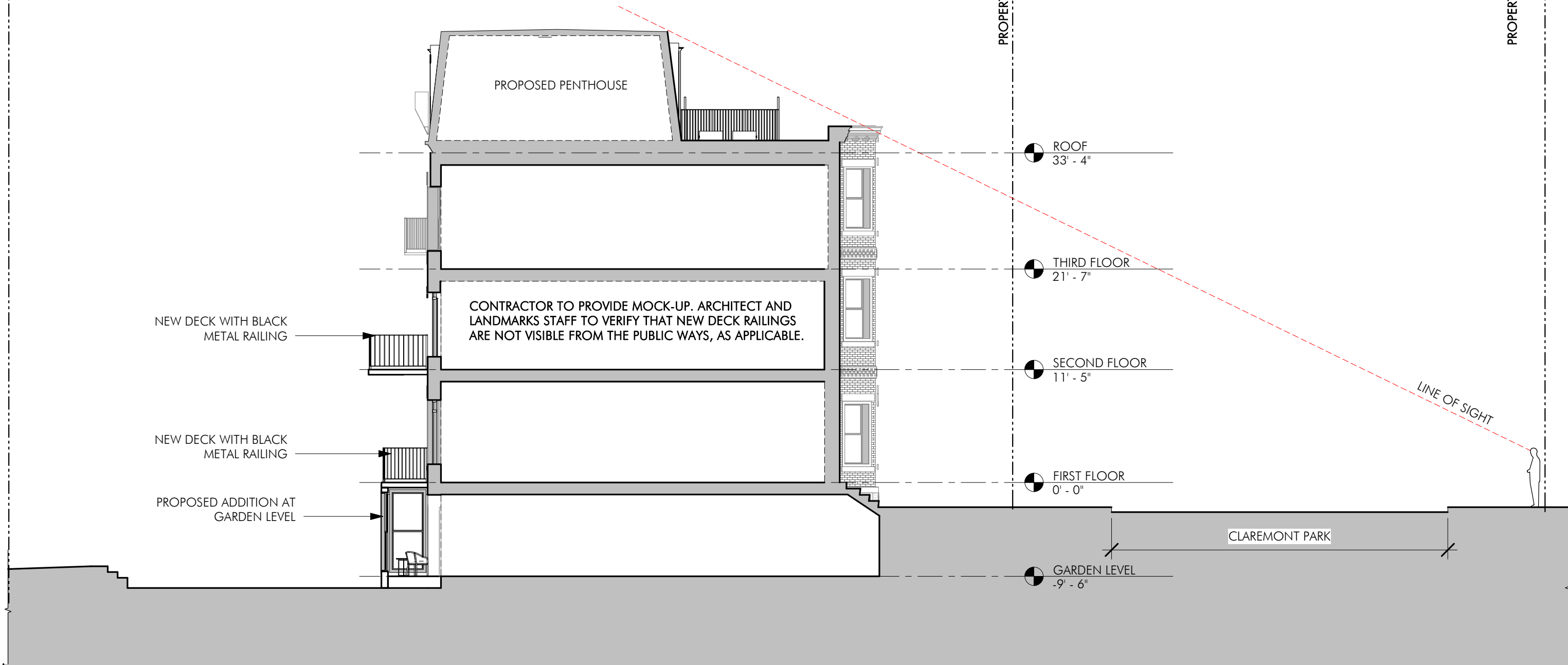



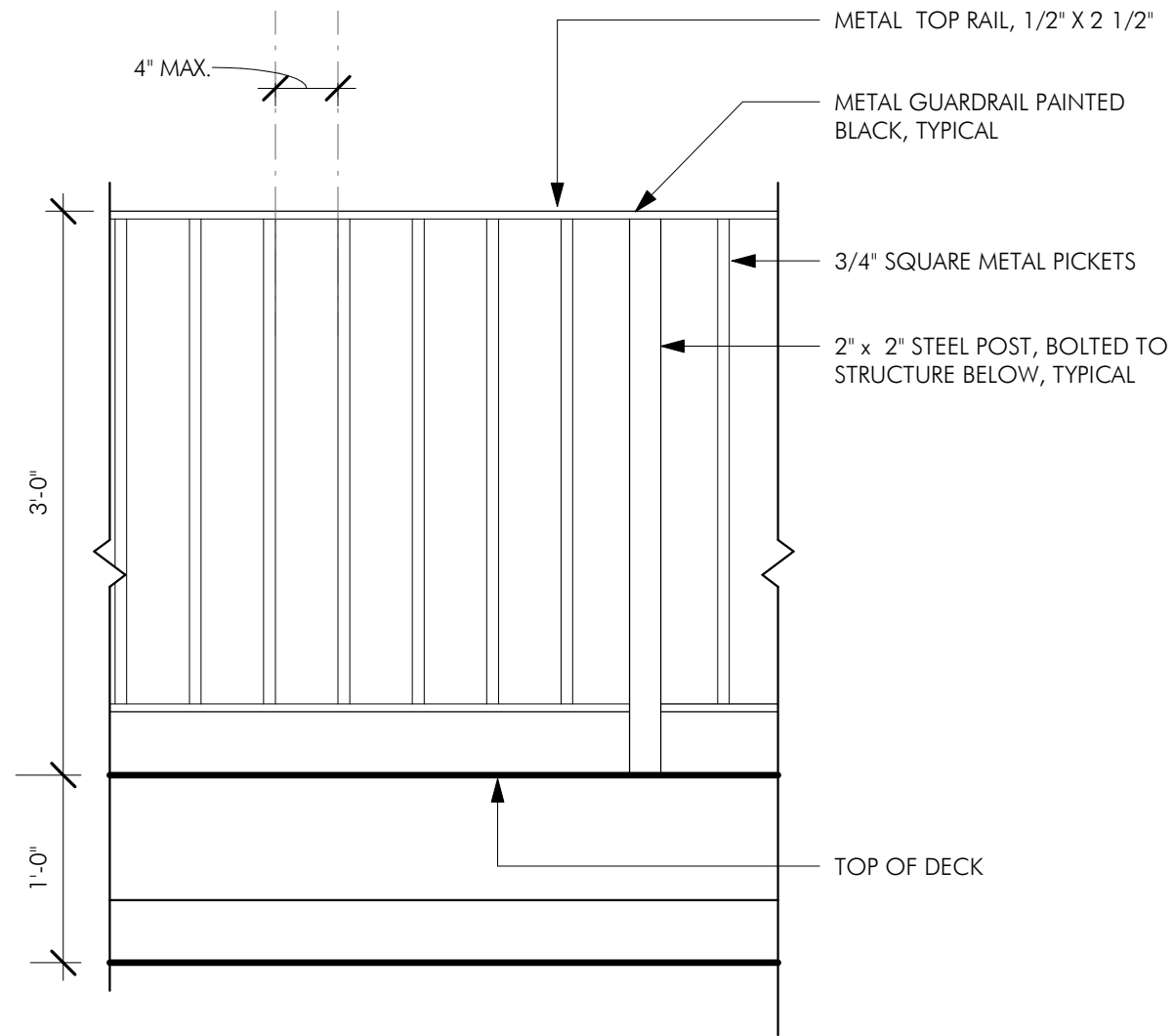

**2** PROPOSED ROOF DECK RAILING ELEVATION  
1" = 1'-0"

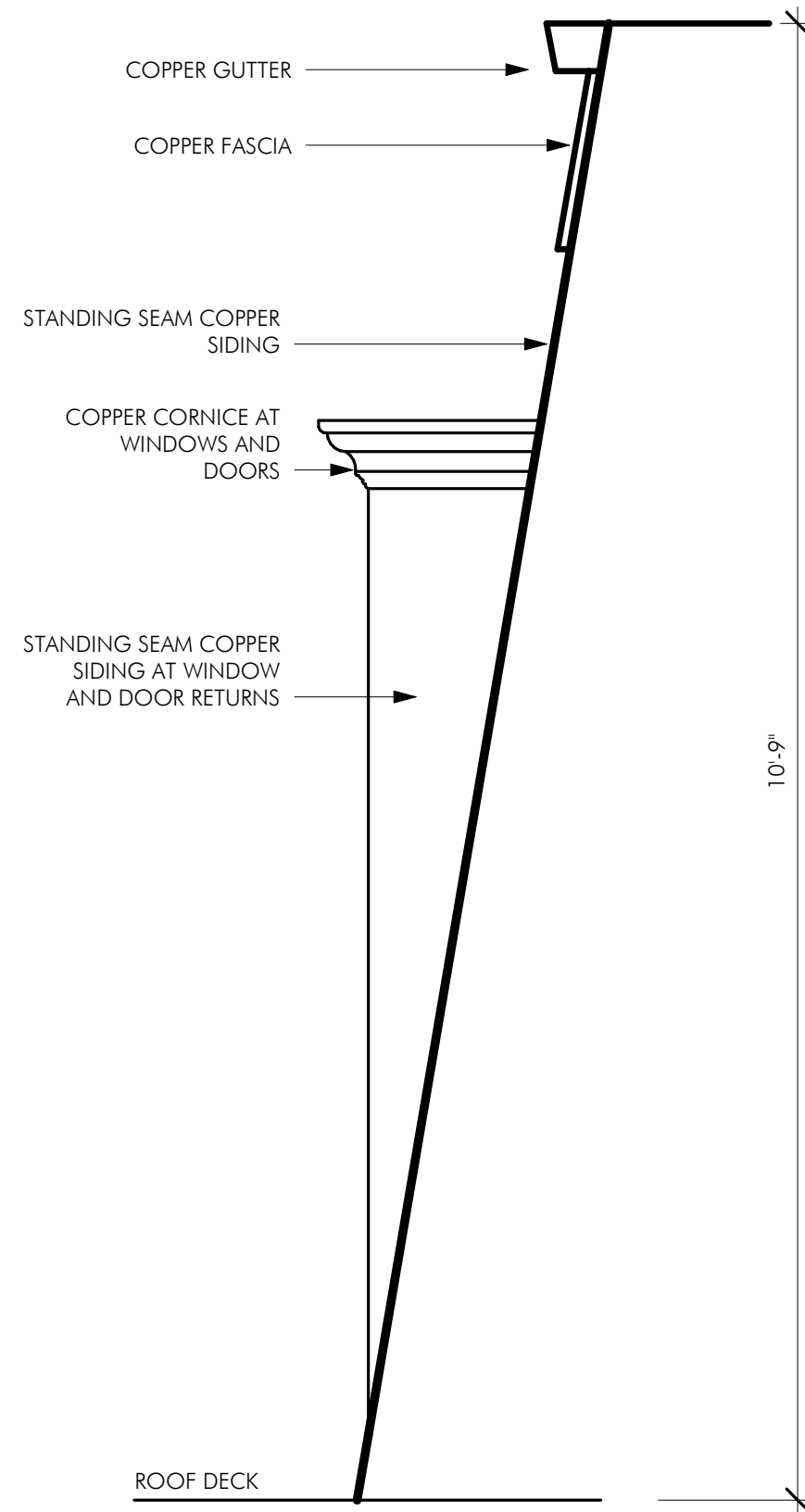

**1** PENTHOUSE PROFILE  
1" = 1'-0"



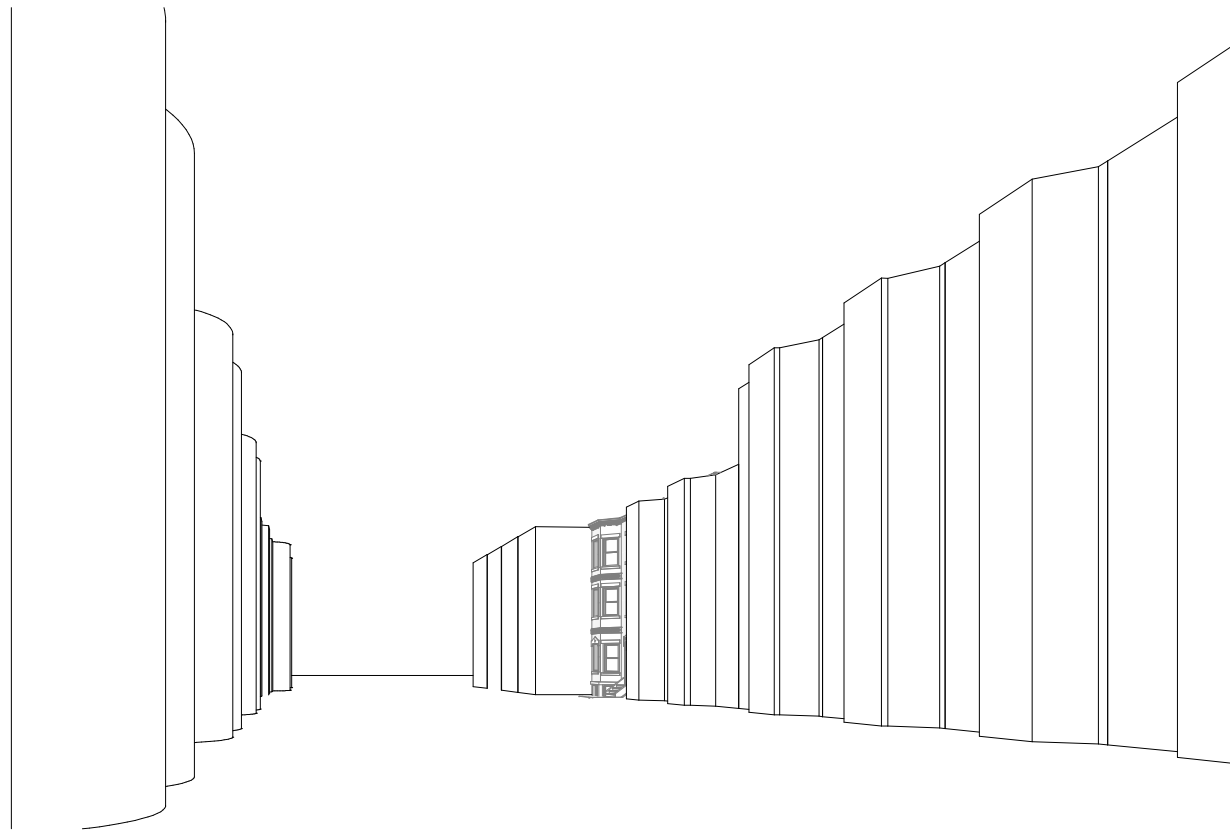

**A** PENTHOUSE PERSPECTIVE A



**B** PENTHOUSE PERSPECTIVE B

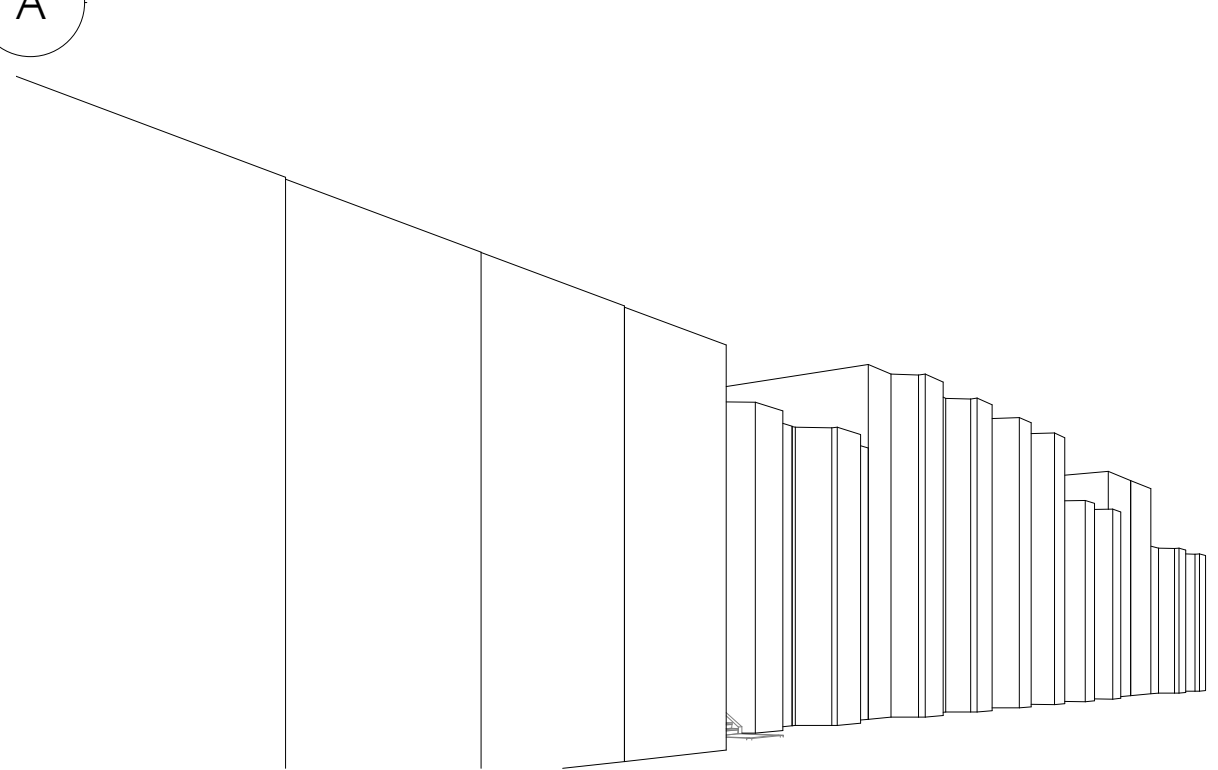

**C** PENTHOUSE PERSPECTIVE C

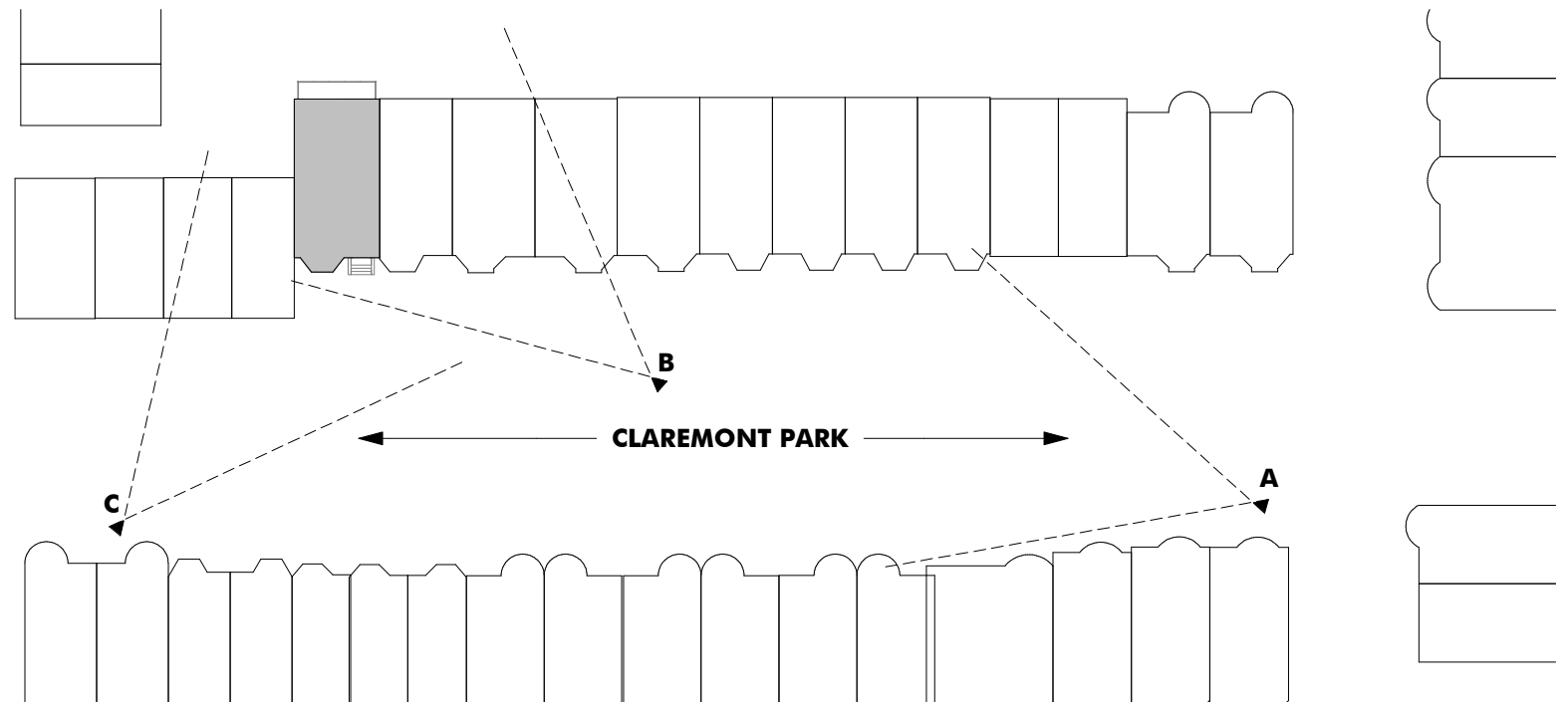









1A



1C



2A



2C



1B



1C

TYPICAL OF 1A, 1B, 1C



2B

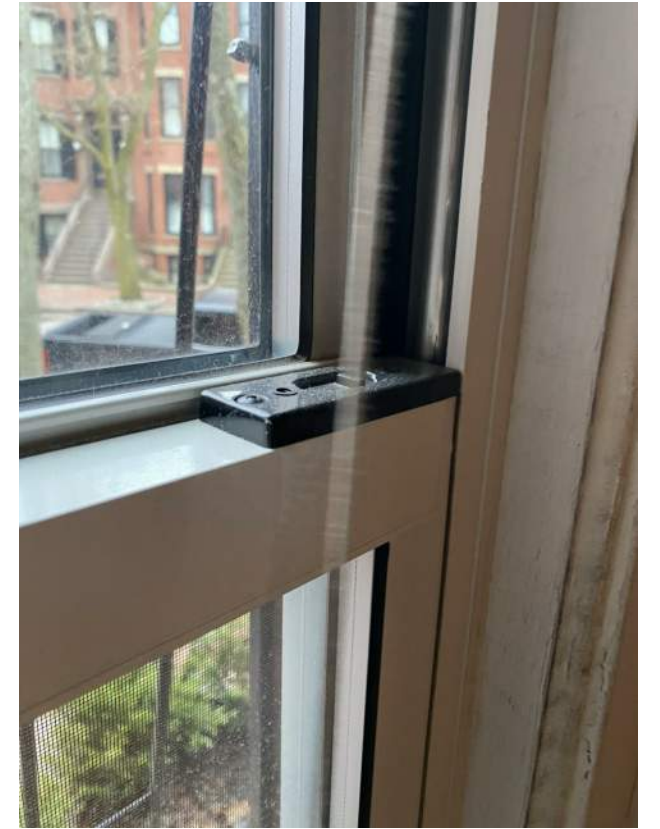

2A

TYPICAL OF 2B, 2C





3A



3C



4A



4C



3B



3D



4B



4D

TYPICAL OF 3A, 3B, 3C

TYPICAL OF 4A, 4B, 4C



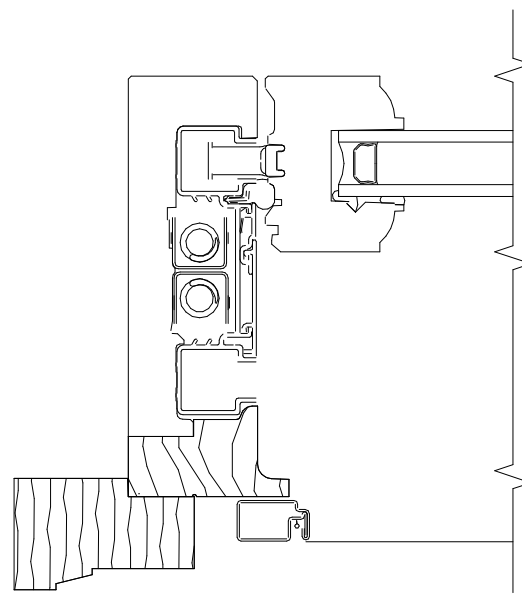
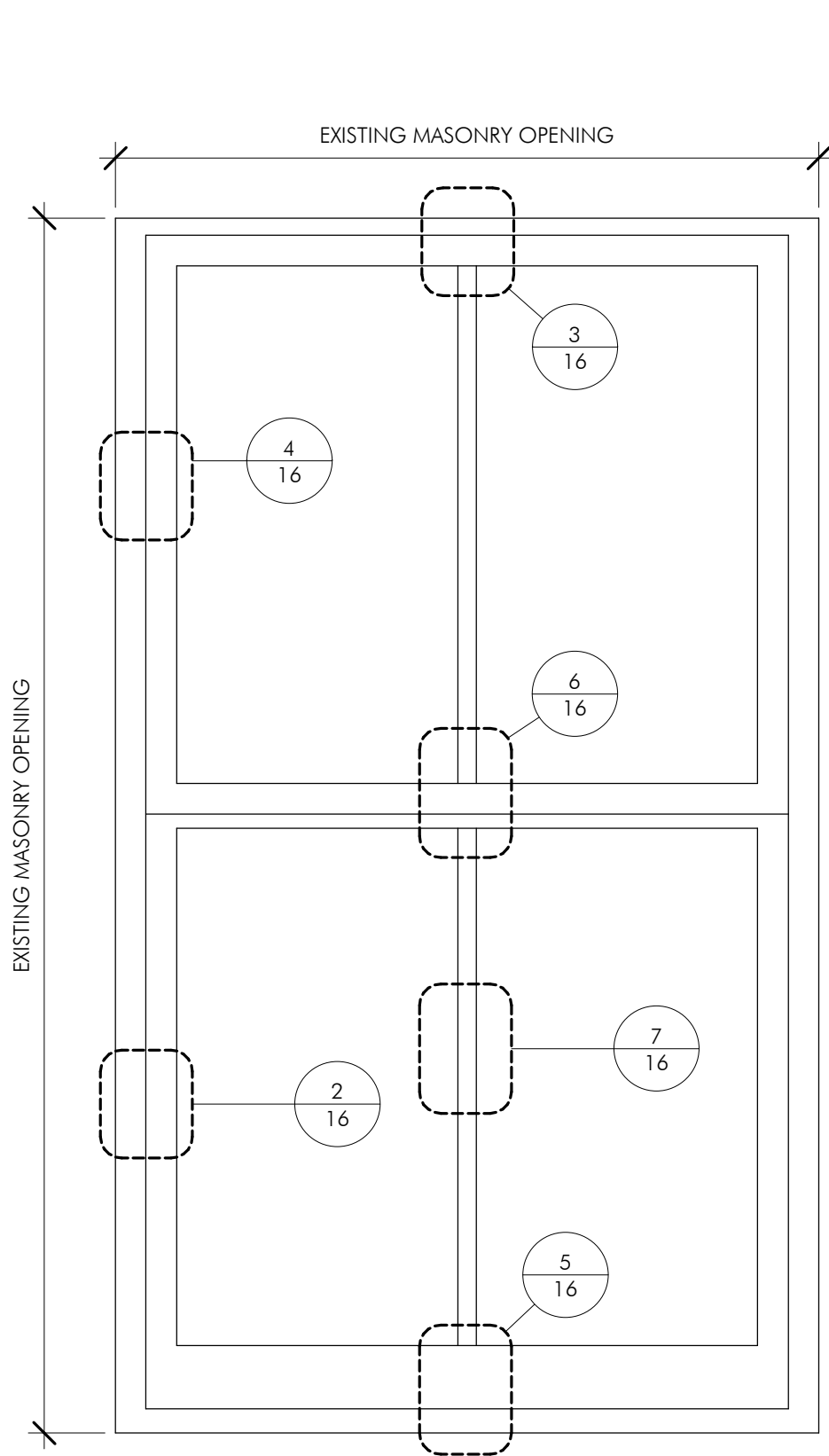

2 LOWER JAMBS  
6" = 1'-0"

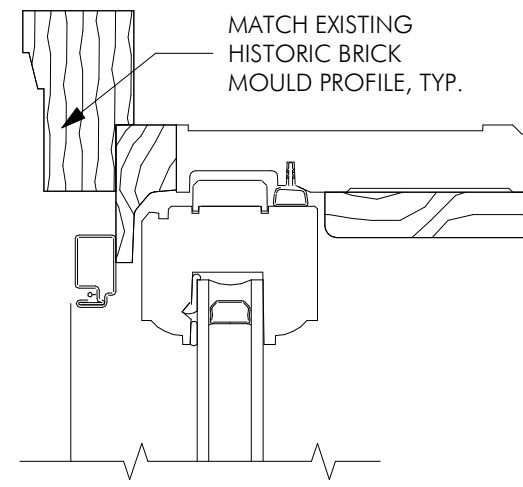

3 VENT HEAD  
6" = 1'-0"

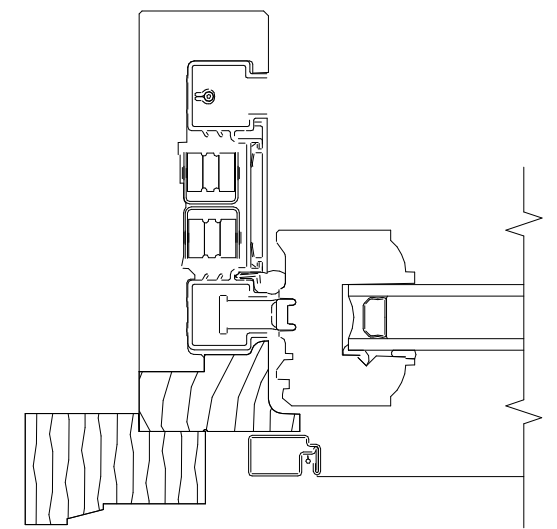

4 UPPER JAMBS  
6" = 1'-0"

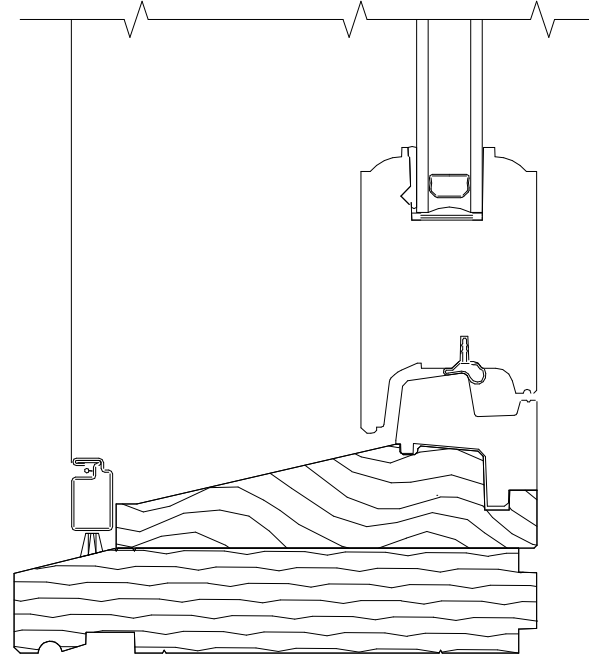

5 VENT SILL  
6" = 1'-0"

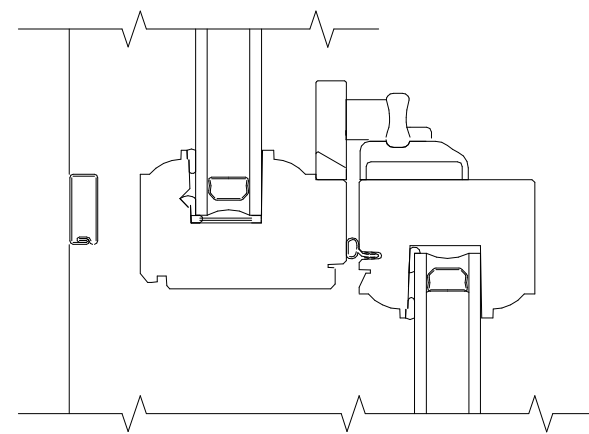

6 CHECK RAIL  
6" = 1'-0"

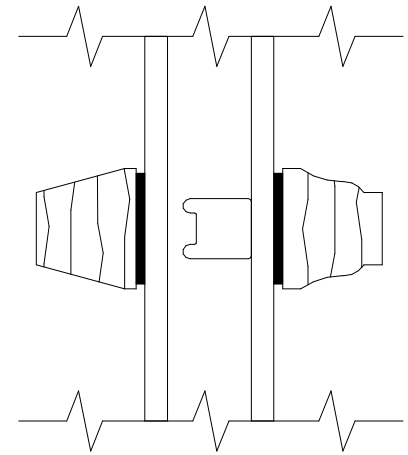

7 GLAZE GRILLES  
12" = 1'-0"