

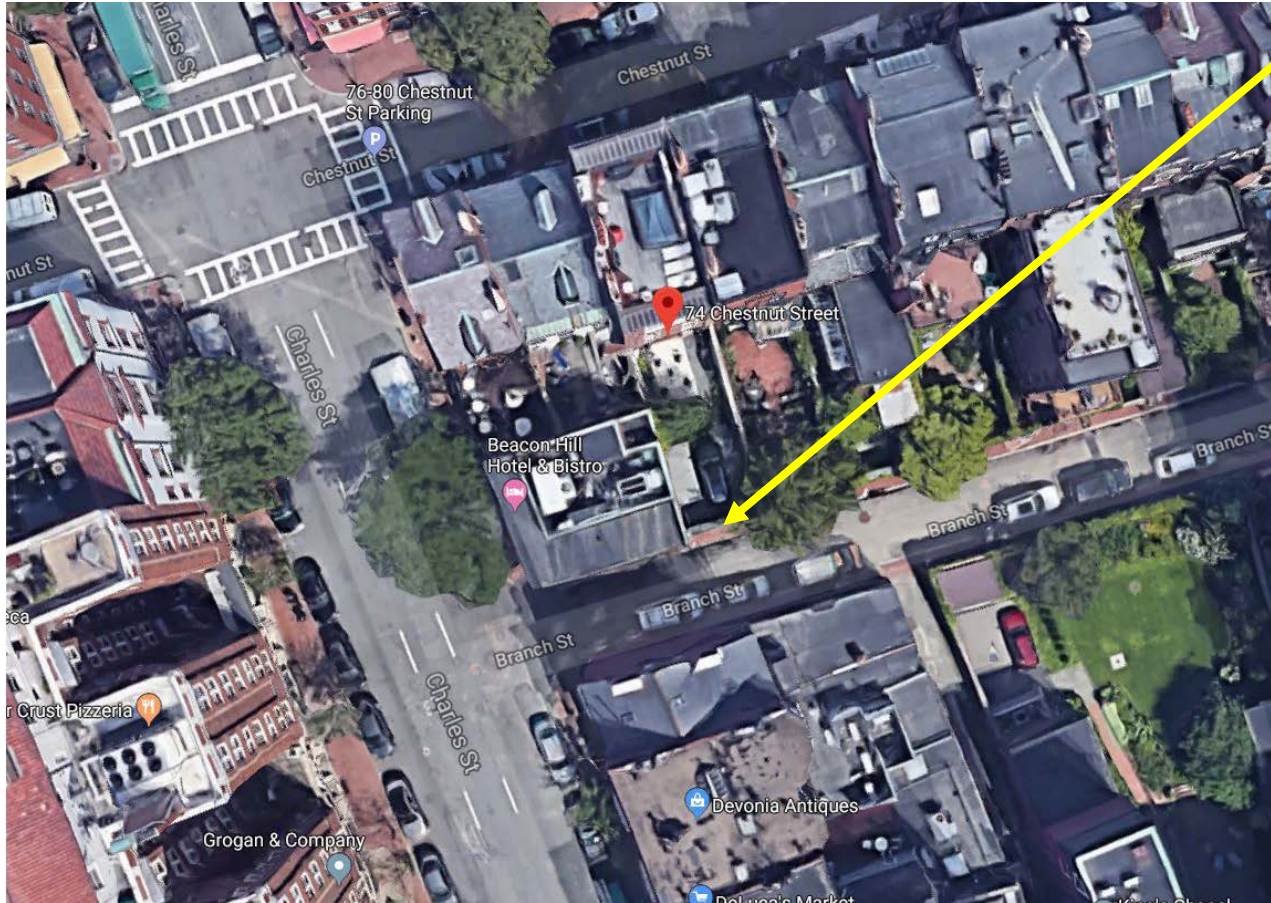

Garage Door Replacement

74 Chestnut St, Boston, MA 02108

Location – Bird's Eye View



- 74 Branch St
- Back of resident's home address of 74 Chestnut St
- Garage door located by intersection of Charles St and Branch St

Location – Charles St View



- 74 Branch St
- Back of resident's home address of 74 Chestnut St
- Garage door located by intersection of Charles St and Branch St

Existing Conditions



(Image taken March 2019)

- **Material**
 - Constructed of cedar
- **Design**
 - Size: 16'0" x 6'8"
 - Style: Custom raised panels / 9 panels wide x 4 panels high
 - Color: Painted semi-gloss black
- **Motor**
 - Side-mounted motor
 - Garage does not have a roof, therefore side-mount is required

RANCH HOUSE DOORS

SH | Redefining the Entrance™

#76834
16-0 X 6-8

INTERIOR EDGES - PLEASE CIRCLE ONE:



SQUARE



EASED



COPED



STEP

CA OFFICE - PH: (951) 278-2884 / FAX: (951) 278-2686
WA OFFICE - PH: (360) 318-1319 / FAX: (360) 318-1320

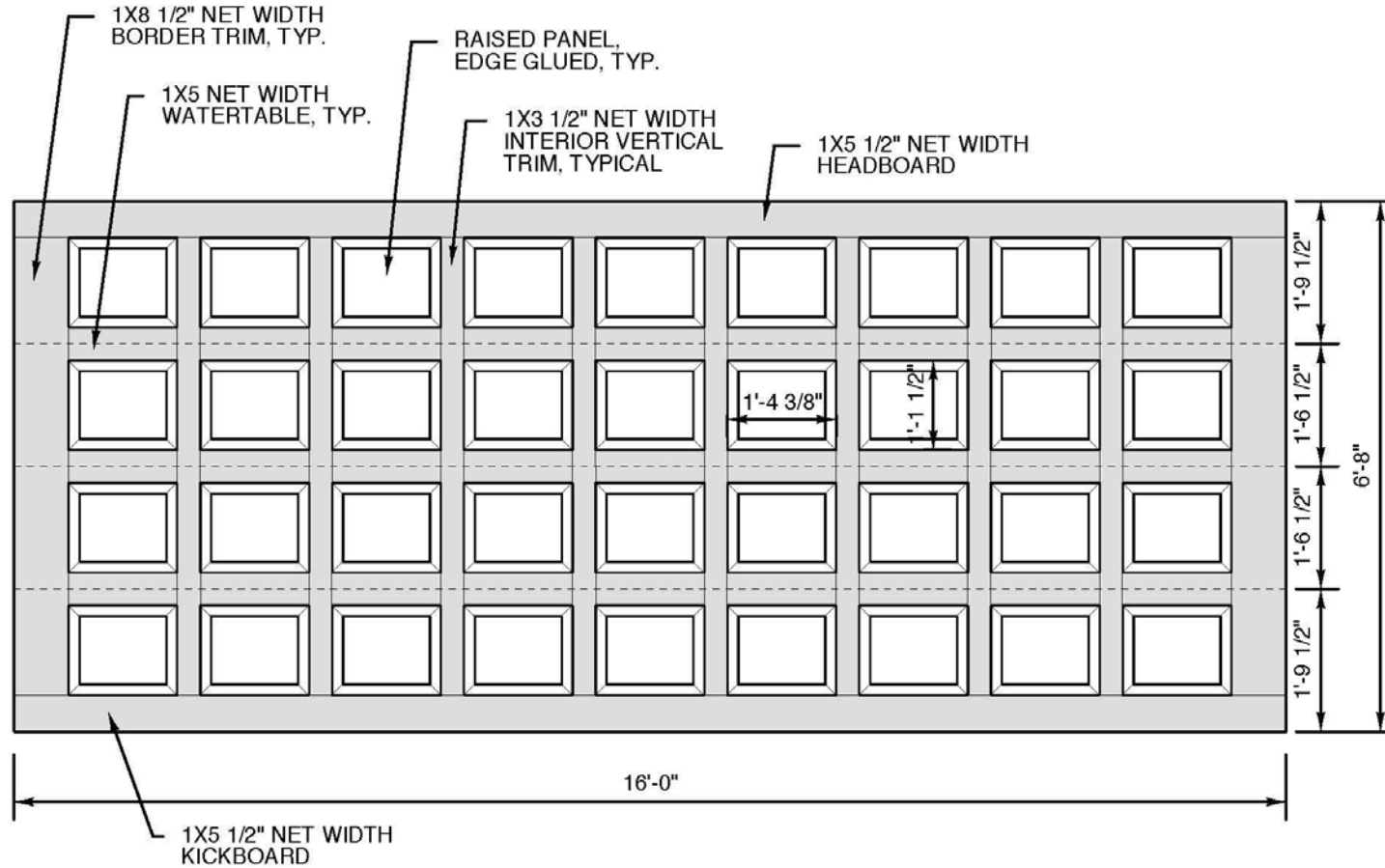

© ALL MATERIAL IS COPYRIGHTED AND CANNOT BE TRANSFERRED TO A THIRD PARTY

DATE: 102915



Reasons For Replacement



(Image taken Feb. 2019)

- **Motor**
 - Because the door is oversized, the existing side-mounted motor has failed and needs replacement.
 - Garage has no roof, therefore installation of overhead motor would be visible from street view. This is non-conforming to the BHAC.

- **Material**
 - Wood naturally retains & loses water. This requires 2x/year adjustments to the springs.
 - If spring adjustments are missed, the spring has potential to break.
 - This happened in Feb. 2019, and spring required replacement.
 - Strain on the spring also contributed to the above mentioned motor failure.

Reasons For Replacement



(Image taken Feb. 2019)

■ Safety

- The existing motor has failed due to weight limitations, and wood door is unable to be opened. This eliminates the rear egress and is a safety concern.
- In the current condition, the cables have the potential to snap. This has happened on one occasion, which had major potential to injure the operator.

■ Longevity

- Current wooden door & side-mounted motor require routine maintenance & upkeep. This has proven challenging and has significant cost implications.
- Paint is peeling and requires regular touch ups. Each gallon of paint adds more weight, further exhausting the spring & motor.



Proposed Design

EXTERIOR VIEW

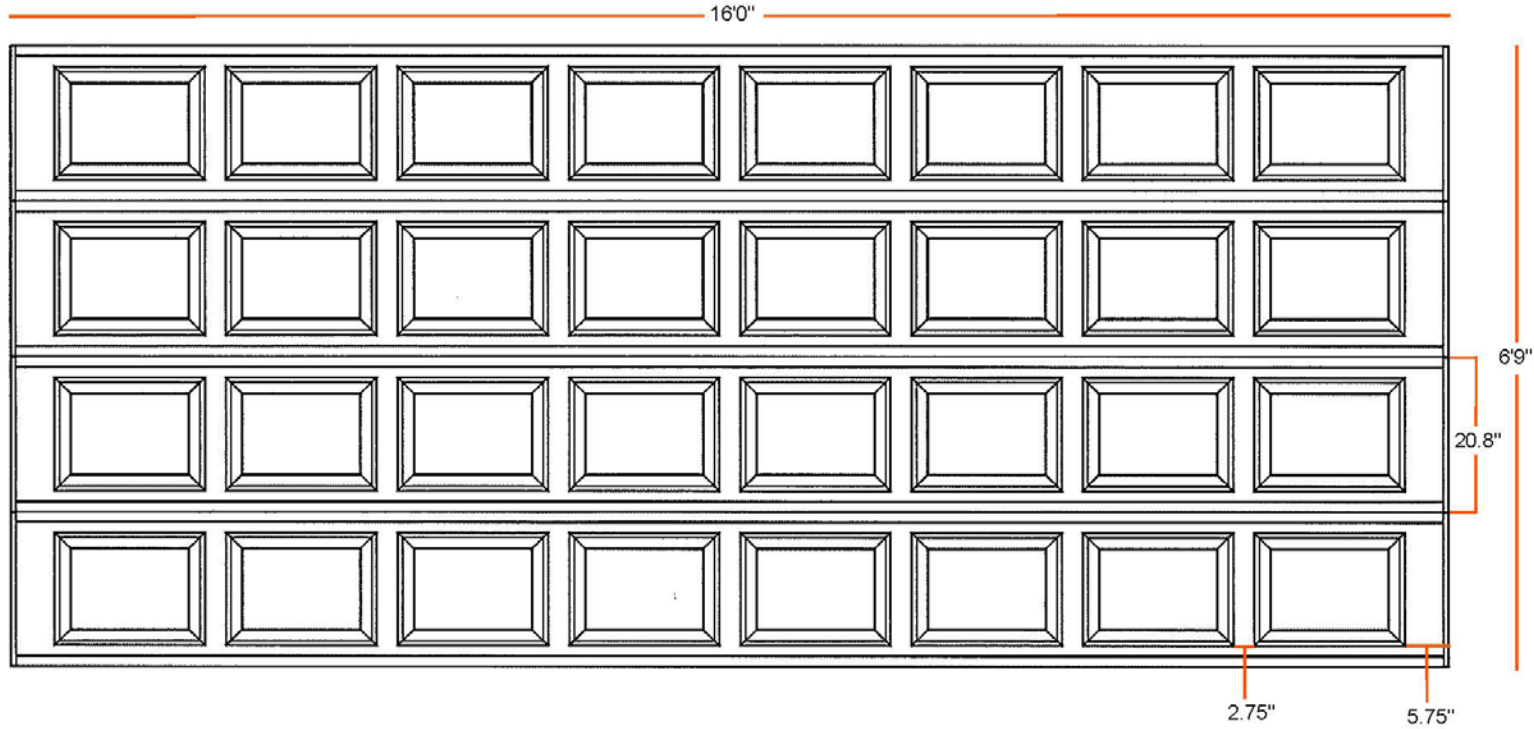

16'0" X 7'0" 8300/8500 CRP DESIGN
4 SECTION/8 PANEL
SOLID TOP SECTION
(4) 20.8" SECTIONS

Close-up of Individual Panels

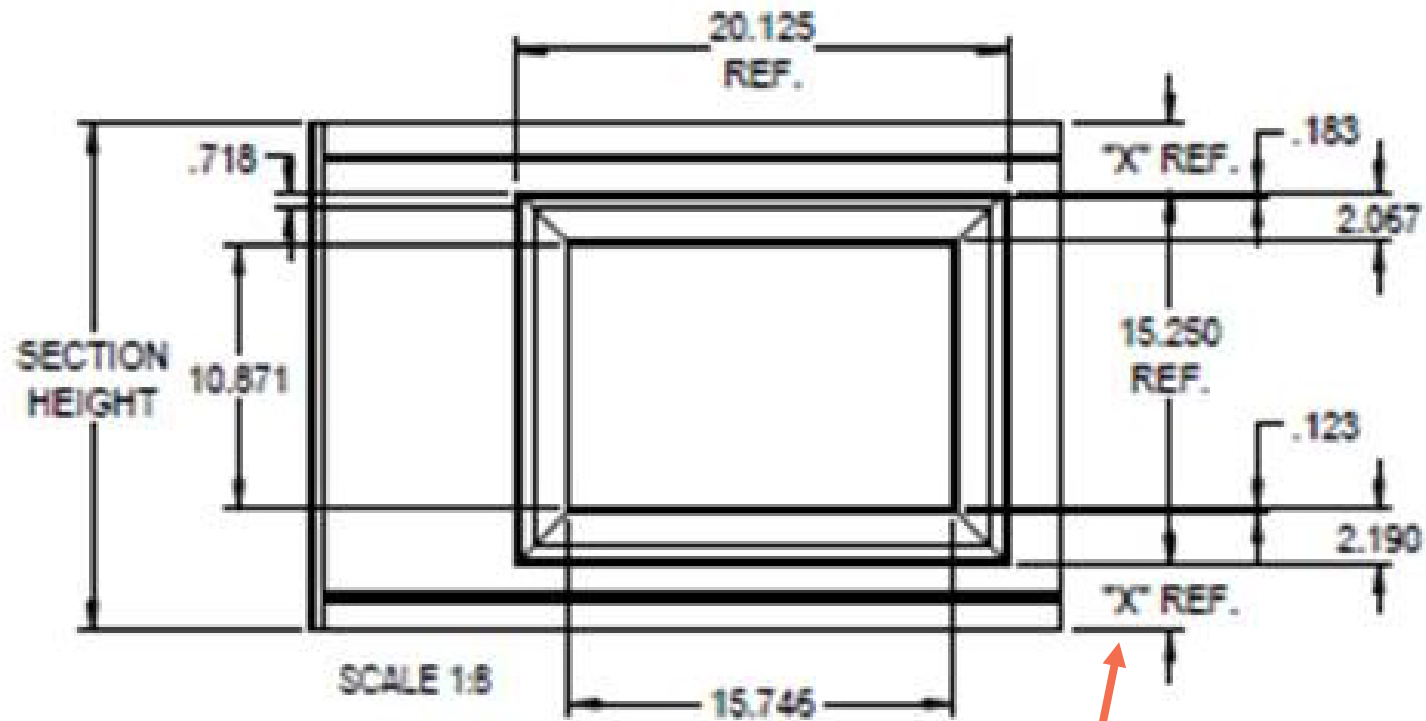

(Reveal size)

SECTION HEIGHT	DIM "X"
24	4.375
20.8	2.775
18	1.375

8300/8500 Model Comparison

	MODEL 8300	MODEL 8500
Door construction	3-layer construction steel/insulation/steel	3-layer construction, steel/insulation/steel 2" thick steel panels
Polyurethane insulation*	Yes	Yes
Insulation R-value**	R-12.12	R-16.22 Highest of all models
Tongue-and-groove section joints to seal out weather	Yes	Yes
Warranty	Limited Lifetime	Limited Lifetime

*Polyurethane insulation provides superior insulation value and thermal efficiency compared to polystyrene.

**Wayne Dalton uses a calculated door section R-value for our insulated doors.

1 Choose Your Style

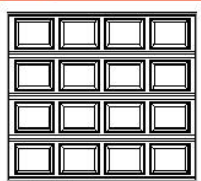

Colonial

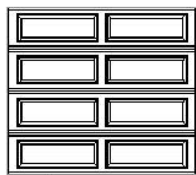

Ranch

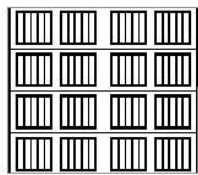

Sonoma

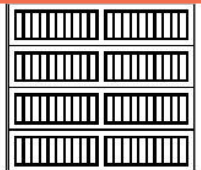

Sonoma Ranch
(Model 8300 only)

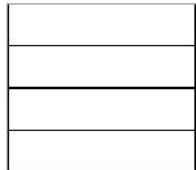

Contemporary

2 Choose Your Color

Paint Finishes



White

Almond

Taupe

Brown

Black

Optional Wood Grain Finishes

Available on Models 8300 and 8500 Sonoma and Model 8300 Sonoma Ranch only



Golden Oak

Walnut

Mission Oak



Available with the TruChoice® Color System, Wayne Dalton's custom painting process that offers more than 6,000 colors. See dealer for details.

Actual colors may vary from brochure due to fluctuations in the printing process. Always request a color sample from your dealer for accurate color matching.



• Key Similarities

- New door to have colonial style profile to conform to existing.
- New door to be painted semi-gloss black to conform with neighborhood & match existing.
 - Exact new paint color is *RAL 9500 Jet Black*
- New door size to match existing 16'0" x 6'9"

• Differences

- New door constructed of steel, rather than wood.
 - Note: Both existing and new door are painted black, and material is not obvious from street view.
- New door colonial panels are slightly rectangular, rather than square.
- New door has (32) total interior panels, rather than (36).

Reasons for Steel

- **Durability**
 - Steel is stronger than wood, and therefore able to withstand the extreme Boston conditions.
 - Black paint will be factory-finished, and unlikely to peel over time.
- **Weight**
 - Steel does not gain or lose weight, the current wooden door does.
 - Because weight will not change, the spring will not need to be adjusted 2x/year, if at all.
 - The motor will not be strained due to fluctuating weight, and unlikely to fail.
- **Maintenance**
 - Current wooden door requires regular attention throughout the year. This has resulted in several emergency service calls due to the spring, cables, or motor breaking.
 - Steel is a reliable product, and will not fluctuate in weight, preventing the above mentioned failures from occurring.

Images of Precedent *(Branch Street)*



QUESTIONS