

599 Tremont St. Apt 2
Owner: Kimberly Vermeer

Presenter: Tagore Hernandez,
Group Design Build

South End Landmarks Commission Meeting December 4,
2018

Application Review:

1. Replace Windows
2. Install Ventilation Grille

599 Tremont Street Apt #2 Condo Unit #7 Boston MA 02118
November 6, 2018



View of existing conditions, 599 Tremont Street. Affected area shown in color.

- 1 - Replace existing window in kind. Wood double hung with center mullions.
- 2- Proposed round ventilation port, painted to match existing entry panel, see detail.

1. Replace Front Windows

- Existing Windows are replacements installed in the mid-1990s—double-hung, 2-over-2.
- Windows were not installed well originally and are now failing:
 - They are not weathertight—significant air leakage
 - Due to window failure moisture builds up between the double panes of the glazing
 - They allow significant dust, dirt and noise to intrude into the unit

Proposed Replacement Windows

- Wood
- Two-over-Two with divided lights
- Curved sash to match radius of the bow
- Double-paned

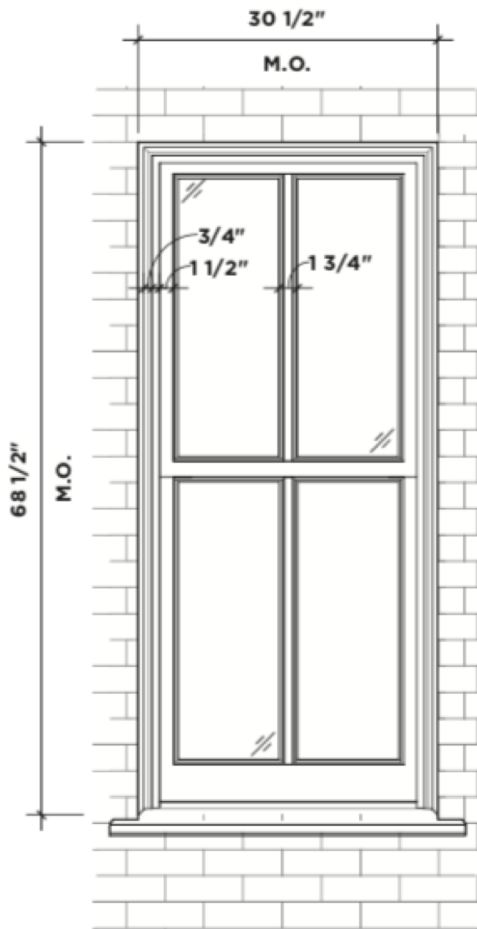

Proposed All Wood Window

PROPOSED ELEVATION
3/4"=1'-0"

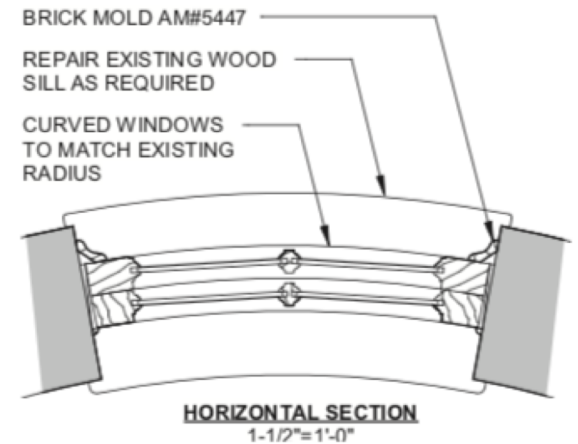
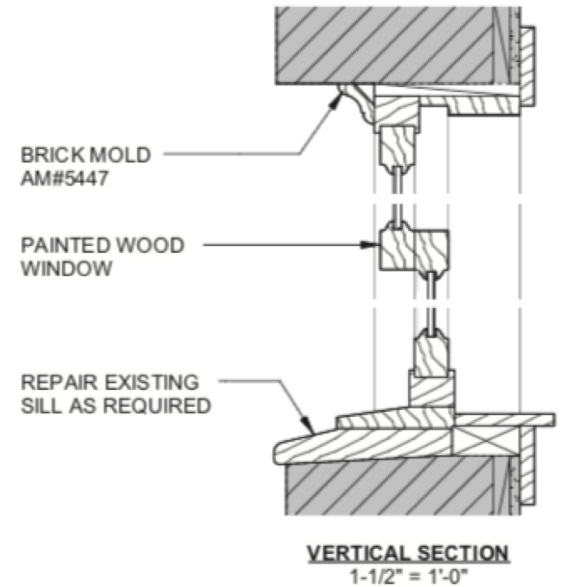

2. Proposed Ventilation Grille

- Intention: Install a Heat Recovery Ventilation (HRV) system to provide controlled fresh air to the unit
- Proposed 2-part system requires a portal at the front and back of the unit



599 Tremont Street Apt #2 Condo Unit #7 Boston MA 02118
November 6, 2018



View of proposed ventilation port at Entry.



Detail of proposed round ventilation port.

- 1 - Replace existing window in kind. Wood double hung with center mullions.
- 2- Proposed round ventilation port, painted to match existing entry panel, see detail.