



Massachusetts Port Authority
One Harborside Drive, Suite 200S
East Boston, MA 02128-2090
Telephone (617) 568-5950
www.massport.com

April 4, 2018

Amelia Croteau
Executive Secretary
Boston Conservation Commission
Boston City Hall - Room 709
Boston, MA 02201

Re: Notice of Intent for Taxi Pool Relocation
Logan Airport
East Boston

Dear Ms. Croteau:

Enclosed please find eight (8) copies of the Notice of Intent (NOI) and project plans associated with the proposed relocation of the Taxi Pool facility at Logan Airport. The taxi pool staging operations, which are currently located adjacent to East Boston Memorial Park, are being shifted back to a surface parking lot adjacent to the Logan Office Center as part of a program to improve traffic flow at the airport. The proposed work is located within the 100-foot Buffer Zone associated with the Coastal Bank.

The NOI was submitted electronically to the Department of Environmental Protection (DEP) via eDEP, and two (2) copies of the NOI and project plans will be sent to the DEP's Northeast Regional Office. A check in the amount of \$1,500 is being processed by Massport's Accounting Department and will be forwarded to you prior to the hearing.

Please feel free to contact me at (617) 568-3552 should you have any questions or need additional information.

Sincerely,
MASSACHUSETTS PORT AUTHORITY

A handwritten signature in blue ink that reads "James Stolecki".

James W. Stolecki, P.E.
Senior Environmental Project Manager

Enclosure

cc: Dan Dragani – Massport



Massachusetts Department of Environmental Protection

Bureau of Resource Protection - Wetlands

WPA Form 3 - Notice of Intent

Massachusetts Wetlands Protection Act M.G.L. c. 131, §40

Provided by MassDEP:

MassDEP File #:

eDEP Transaction #:1001752

City/Town:BOSTON

A.General Information

1. Project Location:

a. Street Address	HARBORSIDE DRIVE - LOGAN AIRPORT		
b. City/Town	BOSTON	c. Zip Code	02128
d. Latitude	42.36056N	e. Longitude	71.02639W
f. Map/Plat #	NA	g.Parcel/Lot #	NA

2. Applicant:

Individual Organization

a. First Name	JAMES	b.Last Name	STOLECKI
c. Organization	MASSACHUSETTS PORT AUTHORITY		
d. Mailing Address	ONE HARBORSIDE DRIVE		
e. City/Town	EAST BOSTON	f. State	MA
g. Zip Code	02128	j. Email	jstolecki@massport.com
h. Phone Number	617-568-3552	i. Fax	

3.Property Owner:

more than one owner

a. First Name	JAMES	b. Last Name	STOLECKI
c. Organization	MASSACHUSETTS PORT AUTHORITY		
d. Mailing Address	ONE HARBORSIDE DRIVE		
e. City/Town	EAST BOSTON	f.State	MA
g. Zip Code	02128	j.Email	jstolecki@massport.com
h. Phone Number	617-568-3552	i. Fax	

4.Representative:

a. First Name		b. Last Name	
c. Organization			
d. Mailing Address			
e. City/Town		f. State	
g. Zip Code		j.Email	
h.Phone Number		i.Fax	

5.Total WPA Fee Paid (Automatically inserted from NOI Wetland Fee Transmittal Form):

a.Total Fee Paid	500.00	b.State Fee Paid	237.50	c.City/Town Fee Paid	262.50
------------------	--------	------------------	--------	----------------------	--------

6.General Project Description:

7a.Project Type:

- | | |
|---|--|
| 1. <input type="checkbox"/> Single Family Home | 2. <input type="checkbox"/> Residential Subdivision |
| 3. <input type="checkbox"/> Limited Project Driveway Crossing | 4. <input type="checkbox"/> Commercial/Industrial |
| 5. <input type="checkbox"/> Dock/Pier | 6. <input type="checkbox"/> Utilities |
| 7. <input type="checkbox"/> Coastal Engineering Structure | 8. <input type="checkbox"/> Agriculture (eg., cranberries, forestry) |
| 9. <input checked="" type="checkbox"/> Transportation | 10. <input type="checkbox"/> Other |

7b.Is any portion of the proposed activity eligible to be treated as a limited project subject to 310 CMR 10.24 (coastal) or 310 CMR 10.53 (inland)?



Massachusetts Department of Environmental Protection

Bureau of Resource Protection - Wetlands

WPA Form 3 - Notice of Intent

Massachusetts Wetlands Protection Act M.G.L. c. 131, §40

Provided by MassDEP:

MassDEP File #:

eDEP Transaction #:1001752

City/Town:BOSTON

- 1. Yes No If yes, describe which limited project applies to this project:
- 2. Limited Project

8. Property recorded at the Registry of Deeds for:

a. County:	b. Certificate:	c. Book:	d. Page:
SUFFOLK		29055	333

B. Buffer Zone & Resource Area Impacts (temporary & permanent)

1. Buffer Zone & Resource Area Impacts (temporary & permanent):

This is a Buffer Zone only project - Check if the project is located only in the Buffer Zone of a Bordering Vegetated Wetland, Inland Bank, or Coastal Resource Area.

2. Inland Resource Areas: (See 310 CMR 10.54 - 10.58, if not applicable, go to Section B.3. Coastal Resource Areas)

Resource Area	Size of Proposed Alteration	Proposed Replacement (if any)
---------------	-----------------------------	-------------------------------

a. <input type="checkbox"/> Bank	1. linear feet	2. linear feet
b. <input type="checkbox"/> Bordering Vegetated Wetland	1. square feet	2. square feet
c. <input type="checkbox"/> Land under Waterbodies and Waterways	1. Square feet	2. square feet
	3. cubic yards dredged	
d. <input type="checkbox"/> Bordering Land Subject to Flooding	1. square feet	2. square feet
	3. cubic feet of flood storage lost	4. cubic feet replaced
e. <input type="checkbox"/> Isolated Land Subject to Flooding	1. square feet	
	2. cubic feet of flood storage lost	3. cubic feet replaced

f. Riverfront Area

- 1. Name of Waterway (if any)
- 2. Width of Riverfront Area (check one)
 - 25 ft. - Designated Densely Developed Areas only
 - 100 ft. - New agricultural projects only
 - 200 ft. - All other projects

3. Total area of Riverfront Area on the site of the proposed project _____ square feet

4. Proposed Alteration of the Riverfront Area:

- a. total square feet b. square feet within 100 ft. c. square feet between 100 ft. and 200 ft.

5. Has an alternatives analysis been done and is it attached to this NOI? Yes No



Massachusetts Department of Environmental Protection

Bureau of Resource Protection - Wetlands

WPA Form 3 - Notice of Intent

Massachusetts Wetlands Protection Act M.G.L. c. 131, §40

Provided by MassDEP:

MassDEP File #:

eDEP Transaction #:1001752

City/Town:BOSTON

6. Was the lot where the activity is proposed created prior to August 1, 1996?

Yes No

3. Coastal Resource Areas: (See 310 CMR 10.25 - 10.35)

Resource Area	Size of Proposed Alteration	Proposed Replacement (if any)
a. <input type="checkbox"/> Designated Port Areas	Indicate size under	Land under the ocean below,
b. <input type="checkbox"/> Land Under the Ocean	1. square feet	
	2. cubic yards dredged	
c. <input type="checkbox"/> Barrier Beaches	Indicate size under Coastal Beaches and/or Coastal Dunes, below	
d. <input type="checkbox"/> Coastal Beaches	1. square feet	2. cubic yards beach nourishment
e. <input type="checkbox"/> Coastal Dunes	1. square feet	2. cubic yards dune nourishment
f. <input type="checkbox"/> Coastal Banks	1. linear feet	
g. <input type="checkbox"/> Rocky Intertidal Shores	1. square feet	
h. <input type="checkbox"/> Salt Marshes	1. square feet	2. sq ft restoration, rehab, crea.
i. <input type="checkbox"/> Land Under Salt Ponds	1. square feet	
	2. cubic yards dredged	
j. <input type="checkbox"/> Land Containing Shellfish	1. square feet	
k. <input type="checkbox"/> Fish Runs	Indicate size under Coastal Banks, Inland Bank, Land Under the Ocean, and/or inland Land Under Waterbodies and Waterways, above	
	1. cubic yards dredged	
l. <input type="checkbox"/> Land Subject to Coastal Storm Flowage	1. square feet	

4. Restoration/Enhancement

Restoration/Replacement

If the project is for the purpose of restoring or enhancing a wetland resource area in addition to the square footage that has been entered in Section B.2.b or B.3.h above, please entered the additional amount here.

a. square feet of BVW

b. square feet of Salt Marsh

5. Projects Involves Stream Crossings

Project Involves Streams Crossings

If the project involves Stream Crossings, please enter the number of new stream crossings/number of replacement stream crossings.



Massachusetts Department of Environmental Protection

Bureau of Resource Protection - Wetlands

WPA Form 3 - Notice of Intent

Massachusetts Wetlands Protection Act M.G.L. c. 131, §40

Provided by MassDEP:

MassDEP File #:

eDEP Transaction #:1001752

City/Town:BOSTON

a. number of new stream crossings

b. number of replacement stream crossings

C. Other Applicable Standards and Requirements

Streamlined Massachusetts Endangered Species Act/Wetlands Protection Act Review

1. Is any portion of the proposed project located in **Estimated Habitat of Rare Wildlife** as indicated on the most recent Estimated Habitat Map of State-Listed Rare Wetland Wildlife published by the Natural Heritage of Endangered Species program (NHESP)?

a. Yes No

If yes, include proof of mailing or hand delivery of NOI to:

Natural Heritage and Endangered Species Program
Division of Fisheries and Wildlife
1 Rabbit Hill Road
Westborough, MA 01581

b. Date of map:AUGUST 2017

If yes, the project is also subject to Massachusetts Endangered Species Act (MESA) review (321 CMR 10.18)...

c. Submit Supplemental Information for Endangered Species Review * (Check boxes as they apply)

1. Percentage/acreage of property to be altered:

(a) within Wetland Resource Area

percentage/acreage

(b) outside Resource Area

percentage/acreage

2. Assessor's Map or right-of-way plan of site

3. Project plans for entire project site, including wetland resource areas and areas outside of wetland jurisdiction, showing existing and proposed conditions, existing and proposed tree/vegetation clearing line, and clearly demarcated limits of work **

a. Project description (including description of impacts outside of wetland resource area & buffer zone)

b. Photographs representative of the site

c. MESA filing fee (fee information available at: <http://www.mass.gov/eea/agencies/dfg/dfw/natural-heritage/regulatory-review/mass-endangered-species-act-mesa/mesa-fee-schedule.html>)

Make check payable to "Natural Heritage & Endangered Species Fund" and **mail to NHESP** at above address

Projects altering 10 or more acres of land, also submit:

d. Vegetation cover type map of site

e. Project plans showing Priority & Estimated Habitat boundaries

d. OR Check One of the following

1. Project is exempt from MESA review. Attach applicant letter indicating which MESA exemption applies. (See 321 CMR 10.14, <http://www.mass.gov/eea/agencies/dfg/dfw/laws-regulations/cmr/321-cmr-1000-massachusetts-endangered-species-act.html#10.14>; the NOI must still be sent to NHESP if the project is within estimated habitat pursuant to 310 CMR 10.37 and 10.59.)

2. Separate MESA review ongoing.

a. NHESP Tracking Number

b. Date submitted to NHESP



Massachusetts Department of Environmental Protection

Bureau of Resource Protection - Wetlands

WPA Form 3 - Notice of Intent

Massachusetts Wetlands Protection Act M.G.L. c. 131, §40

Provided by MassDEP:

MassDEP File #:

eDEP Transaction #:1001752

City/Town:BOSTON

3. Separate MESA review completed.

Include copy of NHESP "no Take" determination or valid Conservation & Management Permit with approved plan.

* Some projects **not** in Estimated Habitat may be located in Priority Habitat, and require NHESP review...

2. For coastal projects only, is any portion of the proposed project located below the mean high waterline or in a fish run?

a. Not applicable - project is in inland resource area only

b. Yes No

If yes, include proof of mailing or hand delivery of NOI to either:

South Shore - Cohasset to Rhode Island,
and the Cape & Islands:

North Shore - Hull to
New Hampshire:

Division of Marine Fisheries -
Southeast Marine Fisheries Station
Attn: Environmental Reviewer
1213 Purchase street - 3rd floor
New Bedford, MA 02740-6694

Division of Marine
Fisheries -
North Shore Office
Attn: Environmental
Reviewer
30 Emerson Avenue
Gloucester, MA 01930

If yes, it may require a Chapter 91 license. For coastal towns in the Northeast Region, please contact MassDEP's Boston Office. For coastal towns in the Southeast Region, please contact MassDEP's Southeast Regional office.

3. Is any portion of the proposed project within an Area of Critical Environmental Concern (ACEC)?

a. Yes No

If yes, provide name of ACEC (see instructions to WPA Form 3 or DEP Website for ACEC locations). **Note:** electronic filers click on Website.

b. ACEC Name

4. Is any portion of the proposed project within an area designated as an Outstanding Resource Water (ORW) as designated in the Massachusetts Surface Water Quality Standards, 314 CMR 4.00?

a. Yes No

5. Is any portion of the site subject to a Wetlands Restriction Order under the Inland Wetlands Restriction Act (M.G.L.c. 131, § 40A) or the Coastal Wetlands Restriction Act (M.G.L.c. 130, § 105)?

a. Yes No

6. Is this project subject to provisions of the MassDEP Stormwater Management Standards?

a. Yes, Attach a copy of the Stormwater Report as required by the Stormwater Management Standards per 310 CMR 10.05(6)(k)-(q) and check if:

1. Applying for Low Impact Development (LID) site design credits (as described in Stormwater Management Handbook Vol.2, Chapter 3)

2. A portion of the site constitutes redevelopment

3. Proprietary BMPs are included in the Stormwater Management System

b. No, Explain why the project is exempt:

1. Single Family Home



Massachusetts Department of Environmental Protection

Bureau of Resource Protection - Wetlands

WPA Form 3 - Notice of Intent

Massachusetts Wetlands Protection Act M.G.L. c. 131, §40

Provided by MassDEP:

MassDEP File #:

eDEP Transaction #:1001752

City/Town:BOSTON

- 2. Emergency Road Repair
- 3. Small Residential Subdivision (less than or equal to 4 single-family houses or less than or equal to 4 units in multi-family housing project) with no discharge to Critical Areas.

D. Additional Information

Applicants must include the following with this Notice of Intent (NOI). See instructions for details.

Online Users: Attach the document transaction number (provided on your receipt page) for any of the following information you submit to the Department by regular mail delivery.

- 1. USGS or other map of the area (along with a narrative description, if necessary) containing sufficient information for the Conservation Commission and the Department to locate the site. (Electronic filers may omit this item.)
- 2. Plans identifying the location of proposed activities (including activities proposed to serve as a Bordering Vegetated Wetland [BVW] replication area or other mitigating measure) relative to the boundaries of each affected resource area.
- 3. Identify the method for BVW and other resource area boundary delineations (MassDEP BVW Field Data Form(s). Determination of Applicability, Order of Resource Area Delineation, etc.), and attach documentation of the methodology.
- 4. List the titles and dates for all plans and other materials submitted with this NOI.

a. Plan Title:	b. Plan Prepared By:	c. Plan Signed/Stamped By:	c. Revised Final Date:	e. Scale:
EXISTING CONDITIONS	KATIE MOULTON		April 4, 2018	
SEDIMENTATION AND EROSION CONTROL	KATIE MOULTON		April 4, 2018	
DETAILS	KATIE MOULTON		April 4, 2018	
UTILITY PLAN	KATIE MOULTON		April 4, 2018	

- 5. If there is more than one property owner, please attach a list of these property owners not listed on this form.
- 6. Attach proof of mailing for Natural Heritage and Endangered Species Program, if needed.
- 7. Attach proof of mailing for Massachusetts Division of Marine Fisheries, if needed.
- 8. Attach NOI Wetland Fee Transmittal Form.
- 9. Attach Stormwater Report, if needed.



Massachusetts Department of Environmental Protection

Bureau of Resource Protection - Wetlands

WPA Form 3 - Notice of Intent

Massachusetts Wetlands Protection Act M.G.L. c. 131, §40

Provided by MassDEP:

MassDEP File #:

eDEP Transaction #:1001752

City/Town:BOSTON

E. Fees

1. Fee Exempt: No filing fee shall be assessed for projects of any city, town, county, or district of the Commonwealth, federally recognized Indian tribe housing authority, municipal housing authority, or the Massachusetts Bay Transportation Authority.

Applicants must submit the following information (in addition to pages 1 and 2 of the NOI Wetland Fee Transmittal Form) to confirm fee payment:

2. Municipal Check Number	3. Check date
4. State Check Number	5. Check date
6. Payer name on check: First Name	7. Payer name on check: Last Name

F. Signatures and Submittal Requirements

I hereby certify under the penalties of perjury that the foregoing Notice of Intent and accompanying plans, documents, and supporting data are true and complete to the best of my knowledge. I understand that the Conservation Commission will place notification of this Notice in a local newspaper at the expense of the applicant in accordance with the wetlands regulations, 310 CMR 10.05(5)(a).

I further certify under penalties of perjury that all abutters were notified of this application, pursuant to the requirements of M.G.L. c. 131, § 40. Notice must be made by Certificate of Mailing or in writing by hand delivery or certified mail (return receipt requested) to all abutters within 100 feet of the property line of the project location.

James Stolecki	4/4/2018
1. Signature of Applicant	2. Date
Massport	4/4/2018
3. Signature of Property Owner(if different)	4. Date
5. Signature of Representative (if any)	6. Date

For Conservation Commission:

Two copies of the completed Notice of Intent (Form 3), including supporting plans and documents, two copies of the NOI Wetland Fee Transmittal Form, and the city/town fee payment, to the Conservation Commission by certified mail or hand delivery.

For MassDEP:

One copy of the completed Notice of Intent (Form 3), including supporting plans and documents, one copy of the NOI Wetland Fee Transmittal Form, and a copy of the state fee payment to the MassDEP Regional Office (see Instructions) by certified mail or hand delivery.

Other:

If the applicant has checked the "yes" box in Section C, Items 1-3, above, refer to that section and the Instructions for additional submittal requirements.

The original and copies must be sent simultaneously. Failure by the applicant to send copies in a timely manner may result in dismissal of the Notice of Intent.



Massachusetts Department of Environmental Protection
 Bureau of Resource Protection - Wetlands
WPA Form 3 - Notice of Wetland Fee Transmittal
Form

Massachusetts Wetlands Protection Act M.G.L. c. 131, §40

Provided by MassDEP:
 MassDEP File #:
 eDEP Transaction #:1001752
 City/Town:BOSTON

A. Applicant Information

1. Applicant:

a. First Name JAMES b.Last Name STOLECKI
 c. Organization MASSACHUSETTS PORT AUTHORITY
 d. Mailing Address ONE HARBORSIDE DRIVE
 e. City/Town EAST BOSTON f. State MA g. Zip Code 02128
 h. Phone Number 6175683552 i. Fax j. Email jstolecki@massport.com

2. Property Owner:(if different)

a. First Name JAMES b. Last Name STOLECKI
 c. Organization MASSACHUSETTS PORT AUTHORITY
 d. Mailing Address ONE HARBORSIDE DRIVE
 e. City/Town EAST BOSTON f.State MA g. Zip Code 02128
 h. Phone Number 6175683552 i. Fax j.Email jstolecki@massport.com

3. Project Location:

a. Street Address HARBORSIDE DRIVE - LOGAN AIRPORT b. City/Town BOSTON

Are you exempted from Fee?

Note: Fee will be exempted if you are one of the following:

- City/Town/County/District
- Municipal Housing Authority
- Indian Tribe Housing Authority
- MBTA

State agencies are only exempt if the fee is less than \$100

B. Fees

Activity Type	Activity Number	Activity Fee	RF Multiplier	Sub Total
A.) CONSTRUCTION OF SINGLE FAMILY HOUSE;	1	500.00		500.00

City/Town share of filling fee	State share of filing fee	Total Project Fee
\$262.50	\$237.50	\$500.00

PROJECT DESCRIPTION

The proposed project consists of making modifications to a surface parking lot to accommodate the relocation of the existing Taxi Pool facility at Logan Airport. The surface parking lot is located adjacent to the Logan Office Center as shown on the attached Location Plan. The current Taxi Pool is adjacent to the East Boston Memorial Park. The relocation of the taxi staging operations is part of a program to improve traffic flow at Logan Airport.

The existing surface parking lot was previously used for taxi staging operations during construction of the Consolidated Rental Car facility. At that time, Massport constructed a building for the taxi drivers as well as installing infrastructure and site utilities including improvements to the stormwater drainage system. That work was reviewed by the Conservation Commission which issued an Order of Conditions in March 2010 under DEP File number 006-1223.

As shown on attached drawing ____, site work to be conducted within the 100-foot Buffer Zone will consist of the following:

- Trenching for electrical conduit installation to power vehicle charging stations
- Electrical transformer and load center pads (concrete)
- Installation of posts for the charging stations
- Additional plantings along the Harborwalk

In addition to the above project components, work to be conducted outside of the Buffer Zone include constructing a prayer building and smoking shelter. There will be a raised median as shown on Drawing ____ that will have a crushed stone surface and an underdrain connected to the existing storm drain. There is no other drainage work proposed.

The tables provided on the plans indicate there will be an increase in pervious area of approximately 4100 square feet due to the removal of existing pavement and concrete and installation of the pervious median described above. Stormwater runoff from the paved surfaces will flow to the two existing “Stormceptor” stormwater treatment units that are designed to removed Total Suspended Solids and petroleum.

Stormwater from the area containing the proposed project site discharges to Massport’s West Outfall which is covered under Logan Airport’s National Pollution Discharge Elimination System (NPDES) permit. Massport operates and maintains pollution control equipment at the outfall consisting of a bar screen and oil skimmer unit.

STORMWATER REPORT

Each of the standard contained in the Massachusetts Stormwater Management Standards is addressed below and summarized in the attached Checklist.

PROJECT DESCRIPTION

Taxi Pool Relocation

Notice of Intent

Standard 1: No New Untreated Discharges

As stated above, there will be no new impervious area created by the project and, therefore, no new discharges will be introduced into the stormwater system.

Standard 2: Peak Rate Attenuation

Because stormwater runoff from the drainage area discharges to Boston Harbor, there is no requirement to attenuate the peak rate of runoff. However, there will be a decrease in the runoff rate due to the reduction in impervious area.

Standard 3: Recharge

There will be an increase in the recharge rate under the post-development condition due to an increase in pervious area including the raised crushed stone median.

Standard 4: Water Quality

The proposed Taxi Pool Relocation site is currently a parking lot, and the area is covered under NPDES Permit No. 0000787 that EPA issued for Logan Airport in 2007. The permit required that Massport develop and implement a Stormwater Pollution Prevention Plan (SWPPP) to address all activities at the airport including parking areas.

The Best Management Practices identified in the SWPPP and adhered to by Massport include the following:

- Pavement Sweeping – The paved areas, including streets and parking areas are swept on a continuous basis using vacuum and brush-type sweepers.
- Maintenance of Drainage Structures – Catch basins and stormwater treatment units (e.g. Stormceptors) are inspected on an annual basis and cleaned as necessary. In areas of high sediment loading, filter inserts are installed in catch basins.
- Pollution Control Equipment at Outfalls – The equipment is inspected and maintained on a weekly basis, at a minimum.

This site was previously modified from an overflow parking lot to the taxi pool holding area in 2010 and the drainage system upgraded at that time included two stormceptor systems that will remain. The TSS removal at that time was calculated at 78%, which was attributed to the two stormwater treatment units, and complied with the “maximum extent practicable” requirement for redevelopment projects. As the site is going back to the taxi pool holding area and no new drainage is anticipated for this project, the TSS removal rate will remain at 78%.

Standard 5: Land Uses with Higher Potential Pollutant Loads (LUHPPLs)

As stated under Standard 4, Massport has implemented a Stormwater Pollution Prevention Plan (SWPPP) in accordance with its NPDES stormwater permit. In addition to the Best Management Practices (BMPs) listed under Standard 4, the following BMPs are in place:

- Pollution Prevention Team – The SWPPP identifies Massport employees who are responsible for implementing and documenting the BMPs.
- SWPPP Inspections – All areas of the airport are inspected on a monthly basis to identify potential pollution sources.

PROJECT DESCRIPTION

Taxi Pool Relocation

Notice of Intent

- Spill Prevention and Response – Massport has a full-time Emergency Response Contractor at the airport.

Standard 6: Critical Areas

This standard is not applicable because stormwater from the site does not discharge to a critical area as defined by the Stormwater Management Standards.

Standard 7: Redevelopment Subject to Standards only to the maximum extent practicable

This standard does apply to the Taxi Pool Relocation project as it is considered a redevelopment project. Accordingly, Standard 4 has been met to the maximum extent practicable (Standards 2 and 6 are not applicable for the reasons previously stated).

Standard 8: Construction Period Pollution Prevention and Erosion and Sedimentation Control

The contract specifications for the Taxi Pool Relocation project will require the contractor to install and maintain erosion and sedimentation controls around the limits of work. These controls are shown on plan NOI2 which is attached to the Notice of Intent.

Standard 9: Operation and Maintenance Plan

The information required under Standard 9 is contained in the SWPPP that has been developed and implemented for Logan Airport. The SWPPP identifies responsible individuals and provides a schedule for routine inspection and maintenance of stormwater structural controls. These controls include catch basins and stormwater treatment units which are inspected and cleaned of accumulated sediment on a routine basis.

Standard 10: Prohibition of Illicit Discharges

There are currently no sanitary sewer lines within the parking lot area. During the renovation to the existing Taxi Pool building and during the construction of the proposed new building, measures will be taken to ensure proper connection of utilities and prevention of illicit discharges to the stormwater drainage system.

Taxi Pool Relocation

Write a description for your map.

Legend

↓ PROJECT LOCATION

↓ PROJECT LOCATION



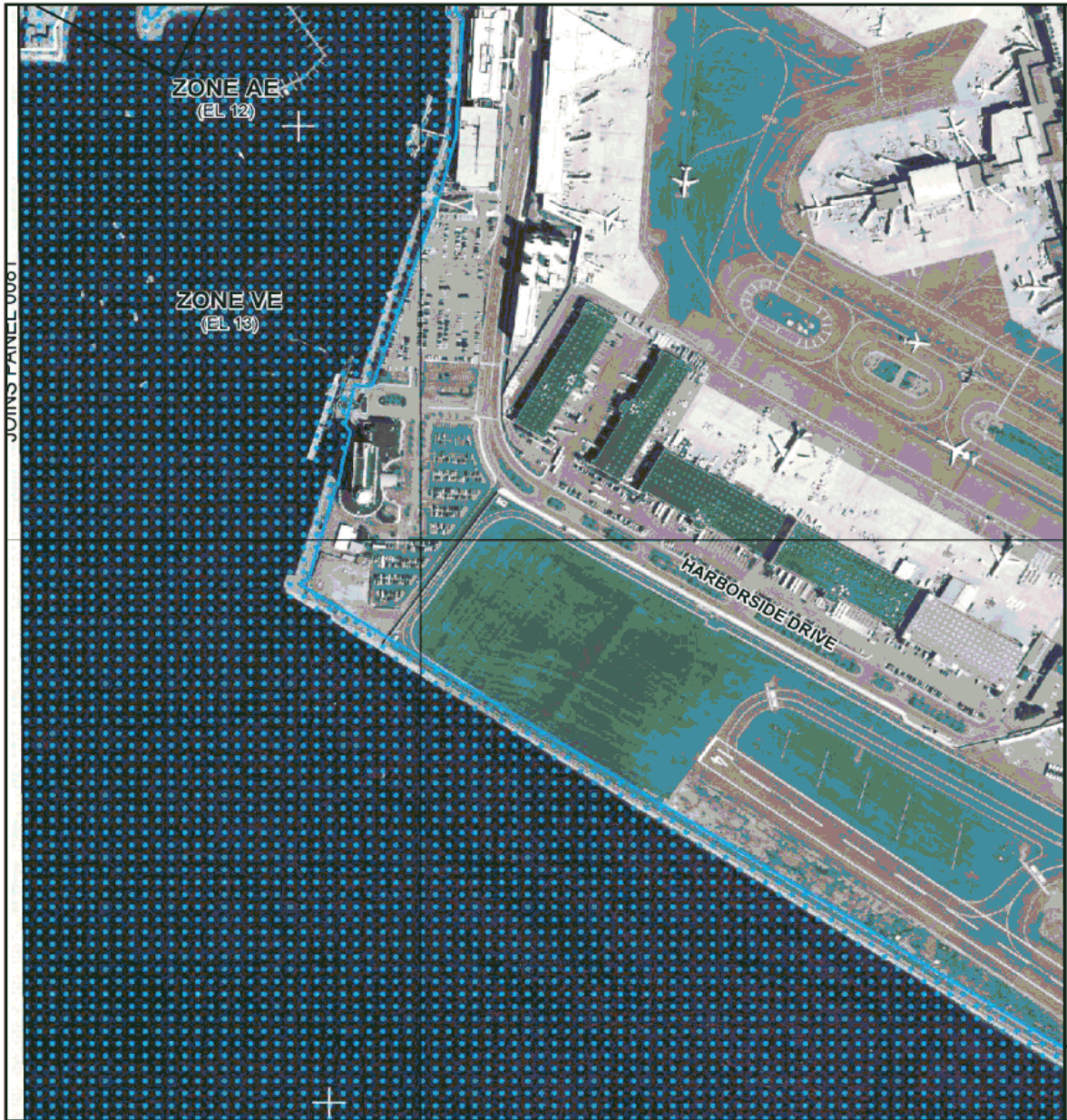

MAP SCALE 1" = 500'



NFP

NATIONAL FLOOD INSURANCE PROGRAM

PANEL 0082J

FIRM

FLOOD INSURANCE RATE MAP
SUFFOLK COUNTY,
MASSACHUSETTS
(ALL JURISDICTIONS)

PANEL 82 OF 176

(SEE MAP INDEX FOR FIRM PANEL LAYOUT)

CONTAINS:

COMMUNITY	NUMBER	PANEL	SUFFIX
BOSTON, CITY OF	250286	0082	J
WINTHROP, TOWN OF	250289	0082	J

Notice to User: The **Map Number** shown below should be used when placing map orders; the **Community Number** shown above should be used on insurance applications for the subject community.



MAP NUMBER
25025C0082J

MAP REVISED
MARCH 16, 2016

Federal Emergency Management Agency

This is an official copy of a portion of the above referenced flood map. It was extracted using F-MIT On-Line. This map does not reflect changes or amendments which may have been made subsequent to the date on the title block. For the latest product information about National Flood Insurance Program flood maps check the FEMA Flood Map Store at www.msc.fema.gov



Checklist for Stormwater Report

A. Introduction

Important: When filling out forms on the computer, use only the tab key to move your cursor - do not use the return key.



A Stormwater Report must be submitted with the Notice of Intent permit application to document compliance with the Stormwater Management Standards. The following checklist is NOT a substitute for the Stormwater Report (which should provide more substantive and detailed information) but is offered here as a tool to help the applicant organize their Stormwater Management documentation for their Report and for the reviewer to assess this information in a consistent format. As noted in the Checklist, the Stormwater Report must contain the engineering computations and supporting information set forth in Volume 3 of the [Massachusetts Stormwater Handbook](#). The Stormwater Report must be prepared and certified by a Registered Professional Engineer (RPE) licensed in the Commonwealth.

The Stormwater Report must include:

- The Stormwater Checklist completed and stamped by a Registered Professional Engineer (see page 2) that certifies that the Stormwater Report contains all required submittals.¹ This Checklist is to be used as the cover for the completed Stormwater Report.
- Applicant/Project Name
- Project Address
- Name of Firm and Registered Professional Engineer that prepared the Report
- Long-Term Pollution Prevention Plan required by Standards 4-6
- Construction Period Pollution Prevention and Erosion and Sedimentation Control Plan required by Standard 8²
- Operation and Maintenance Plan required by Standard 9

In addition to all plans and supporting information, the Stormwater Report must include a brief narrative describing stormwater management practices, including environmentally sensitive site design and LID techniques, along with a diagram depicting runoff through the proposed BMP treatment train. Plans are required to show existing and proposed conditions, identify all wetland resource areas, NRCS soil types, critical areas, Land Uses with Higher Potential Pollutant Loads (LUHPPL), and any areas on the site where infiltration rate is greater than 2.4 inches per hour. The Plans shall identify the drainage areas for both existing and proposed conditions at a scale that enables verification of supporting calculations.

As noted in the Checklist, the Stormwater Management Report shall document compliance with each of the Stormwater Management Standards as provided in the Massachusetts Stormwater Handbook. The soils evaluation and calculations shall be done using the methodologies set forth in Volume 3 of the Massachusetts Stormwater Handbook.

To ensure that the Stormwater Report is complete, applicants are required to fill in the Stormwater Report Checklist by checking the box to indicate that the specified information has been included in the Stormwater Report. If any of the information specified in the checklist has not been submitted, the applicant must provide an explanation. The completed Stormwater Report Checklist and Certification must be submitted with the Stormwater Report.

¹ The Stormwater Report may also include the Illicit Discharge Compliance Statement required by Standard 10. If not included in the Stormwater Report, the Illicit Discharge Compliance Statement must be submitted prior to the discharge of stormwater runoff to the post-construction best management practices.

² For some complex projects, it may not be possible to include the Construction Period Erosion and Sedimentation Control Plan in the Stormwater Report. In that event, the issuing authority has the discretion to issue an Order of Conditions that approves the project and includes a condition requiring the proponent to submit the Construction Period Erosion and Sedimentation Control Plan before commencing any land disturbance activity on the site.



Checklist for Stormwater Report

B. Stormwater Checklist and Certification

The following checklist is intended to serve as a guide for applicants as to the elements that ordinarily need to be addressed in a complete Stormwater Report. The checklist is also intended to provide conservation commissions and other reviewing authorities with a summary of the components necessary for a comprehensive Stormwater Report that addresses the ten Stormwater Standards.

Note: Because stormwater requirements vary from project to project, it is possible that a complete Stormwater Report may not include information on some of the subjects specified in the Checklist. If it is determined that a specific item does not apply to the project under review, please note that the item is not applicable (N.A.) and provide the reasons for that determination.

A complete checklist must include the Certification set forth below signed by the Registered Professional Engineer who prepared the Stormwater Report.

Registered Professional Engineer's Certification

I have reviewed the Stormwater Report, including the soil evaluation, computations, Long-term Pollution Prevention Plan, the Construction Period Erosion and Sedimentation Control Plan (if included), the Long-term Post-Construction Operation and Maintenance Plan, the Illicit Discharge Compliance Statement (if included) and the plans showing the stormwater management system, and have determined that they have been prepared in accordance with the requirements of the Stormwater Management Standards as further elaborated by the Massachusetts Stormwater Handbook. I have also determined that the information presented in the Stormwater Checklist is accurate and that the information presented in the Stormwater Report accurately reflects conditions at the site as of the date of this permit application.

Registered Professional Engineer Block and Signature

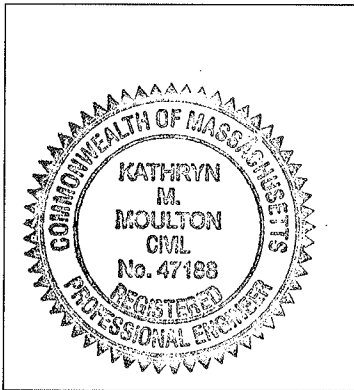

Signature and Date

Kathryn M. Moulton
April 4, 2018

Checklist

Project Type: Is the application for new development, redevelopment, or a mix of new and redevelopment?

- New development
- Redevelopment
- Mix of New Development and Redevelopment



Checklist for Stormwater Report

Checklist (continued)

LID Measures: Stormwater Standards require LID measures to be considered. Document what environmentally sensitive design and LID Techniques were considered during the planning and design of the project:

- No disturbance to any Wetland Resource Areas
- Site Design Practices (e.g. clustered development, reduced frontage setbacks)
- Reduced Impervious Area (Redevelopment Only)
- Minimizing disturbance to existing trees and shrubs
- LID Site Design Credit Requested:
 - Credit 1
 - Credit 2
 - Credit 3
- Use of "country drainage" versus curb and gutter conveyance and pipe
- Bioretention Cells (includes Rain Gardens)
- Constructed Stormwater Wetlands (includes Gravel Wetlands designs)
- Treebox Filter
- Water Quality Swale
- Grass Channel
- Green Roof
- Other (describe): _____

Standard 1: No New Untreated Discharges

- No new untreated discharges
- Outlets have been designed so there is no erosion or scour to wetlands and waters of the Commonwealth
- Supporting calculations specified in Volume 3 of the Massachusetts Stormwater Handbook included.



Checklist for Stormwater Report

Checklist (continued)

Standard 2: Peak Rate Attenuation

- Standard 2 waiver requested because the project is located in land subject to coastal storm flowage and stormwater discharge is to a wetland subject to coastal flooding.
- Evaluation provided to determine whether off-site flooding increases during the 100-year 24-hour storm.
- Calculations provided to show that post-development peak discharge rates do not exceed pre-development rates for the 2-year and 10-year 24-hour storms. If evaluation shows that off-site flooding increases during the 100-year 24-hour storm, calculations are also provided to show that post-development peak discharge rates do not exceed pre-development rates for the 100-year 24-hour storm.

Standard 3: Recharge

- Soil Analysis provided.
- Required Recharge Volume calculation provided.
- Required Recharge volume reduced through use of the LID site Design Credits.
- Sizing the infiltration, BMPs is based on the following method: Check the method used.
 - Static
 - Simple Dynamic
 - Dynamic Field¹
- Runoff from all impervious areas at the site discharging to the infiltration BMP.
- Runoff from all impervious areas at the site is *not* discharging to the infiltration BMP and calculations are provided showing that the drainage area contributing runoff to the infiltration BMPs is sufficient to generate the required recharge volume.
- Recharge BMPs have been sized to infiltrate the Required Recharge Volume.
- Recharge BMPs have been sized to infiltrate the Required Recharge Volume *only* to the maximum extent practicable for the following reason:
 - Site is comprised solely of C and D soils and/or bedrock at the land surface
 - M.G.L. c. 21E sites pursuant to 310 CMR 40.0000
 - Solid Waste Landfill pursuant to 310 CMR 19.000
 - Project is otherwise subject to Stormwater Management Standards only to the maximum extent practicable.
- Calculations showing that the infiltration BMPs will drain in 72 hours are provided.
- Property includes a M.G.L. c. 21E site or a solid waste landfill and a mounding analysis is included.

¹ 80% TSS removal is required prior to discharge to infiltration BMP if Dynamic Field method is used.



Checklist for Stormwater Report

Checklist (continued)

Standard 3: Recharge (continued)

- The infiltration BMP is used to attenuate peak flows during storms greater than or equal to the 10-year 24-hour storm and separation to seasonal high groundwater is less than 4 feet and a mounding analysis is provided.
- Documentation is provided showing that infiltration BMPs do not adversely impact nearby wetland resource areas.

Standard 4: Water Quality

The Long-Term Pollution Prevention Plan typically includes the following:

- Good housekeeping practices;
 - Provisions for storing materials and waste products inside or under cover;
 - Vehicle washing controls;
 - Requirements for routine inspections and maintenance of stormwater BMPs;
 - Spill prevention and response plans;
 - Provisions for maintenance of lawns, gardens, and other landscaped areas;
 - Requirements for storage and use of fertilizers, herbicides, and pesticides;
 - Pet waste management provisions;
 - Provisions for operation and management of septic systems;
 - Provisions for solid waste management;
 - Snow disposal and plowing plans relative to Wetland Resource Areas;
 - Winter Road Salt and/or Sand Use and Storage restrictions;
 - Street sweeping schedules;
 - Provisions for prevention of illicit discharges to the stormwater management system;
 - Documentation that Stormwater BMPs are designed to provide for shutdown and containment in the event of a spill or discharges to or near critical areas or from LUHPPL;
 - Training for staff or personnel involved with implementing Long-Term Pollution Prevention Plan;
 - List of Emergency contacts for implementing Long-Term Pollution Prevention Plan.
- A Long-Term Pollution Prevention Plan is attached to Stormwater Report and is included as an attachment to the Wetlands Notice of Intent.
 - Treatment BMPs subject to the 44% TSS removal pretreatment requirement and the one inch rule for calculating the water quality volume are included, and discharge:
 - is within the Zone II or Interim Wellhead Protection Area
 - is near or to other critical areas
 - is within soils with a rapid infiltration rate (greater than 2.4 inches per hour)
 - involves runoff from land uses with higher potential pollutant loads.
 - The Required Water Quality Volume is reduced through use of the LID site Design Credits.
 - Calculations documenting that the treatment train meets the 80% TSS removal requirement and, if applicable, the 44% TSS removal pretreatment requirement, are provided.

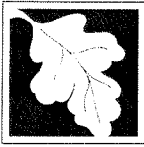

Checklist for Stormwater Report

Checklist (continued)

Standard 4: Water Quality (continued)

- The BMP is sized (and calculations provided) based on:
 - The ½" or 1" Water Quality Volume or
 - The equivalent flow rate associated with the Water Quality Volume and documentation is provided showing that the BMP treats the required water quality volume.
- The applicant proposes to use proprietary BMPs, and documentation supporting use of proprietary BMP and proposed TSS removal rate is provided. This documentation may be in the form of the proprietary BMP checklist found in Volume 2, Chapter 4 of the Massachusetts Stormwater Handbook and submitting copies of the TARP Report, STEP Report, and/or other third party studies verifying performance of the proprietary BMPs.
- A TMDL exists that indicates a need to reduce pollutants other than TSS and documentation showing that the BMPs selected are consistent with the TMDL is provided.

Standard 5: Land Uses With Higher Potential Pollutant Loads (LUHPPLs)

- The NPDES Multi-Sector General Permit covers the land use and the Stormwater Pollution Prevention Plan (SWPPP) has been included with the Stormwater Report.
- The NPDES Multi-Sector General Permit covers the land use and the SWPPP will be submitted *prior* to the discharge of stormwater to the post-construction stormwater BMPs.
- The NPDES Multi-Sector General Permit does *not* cover the land use.
- LUHPPLs are located at the site and industry specific source control and pollution prevention measures have been proposed to reduce or eliminate the exposure of LUHPPLs to rain, snow, snow melt and runoff, and been included in the long term Pollution Prevention Plan.
- All exposure has been eliminated.
- All exposure has *not* been eliminated and all BMPs selected are on MassDEP LUHPPL list.
- The LUHPPL has the potential to generate runoff with moderate to higher concentrations of oil and grease (e.g. all parking lots with >1000 vehicle trips per day) and the treatment train includes an oil grit separator, a filtering bioretention area, a sand filter or equivalent.

Standard 6: Critical Areas

- The discharge is near or to a critical area and the treatment train includes only BMPs that MassDEP has approved for stormwater discharges to or near that particular class of critical area.
- Critical areas and BMPs are identified in the Stormwater Report.



Checklist for Stormwater Report

Checklist (continued)

Standard 7: Redevelopments and Other Projects Subject to the Standards only to the maximum extent practicable

- The project is subject to the Stormwater Management Standards only to the maximum Extent Practicable as a:
- Limited Project
 - Small Residential Projects: 5-9 single family houses or 5-9 units in a multi-family development provided there is no discharge that may potentially affect a critical area.
 - Small Residential Projects: 2-4 single family houses or 2-4 units in a multi-family development with a discharge to a critical area
 - Marina and/or boatyard provided the hull painting, service and maintenance areas are protected from exposure to rain, snow, snow melt and runoff
 - Bike Path and/or Foot Path
 - Redevelopment Project
 - Redevelopment portion of mix of new and redevelopment.
- Certain standards are not fully met (Standard No. 1, 8, 9, and 10 must always be fully met) and an explanation of why these standards are not met is contained in the Stormwater Report.
- The project involves redevelopment and a description of all measures that have been taken to improve existing conditions is provided in the Stormwater Report. The redevelopment checklist found in Volume 2 Chapter 3 of the Massachusetts Stormwater Handbook may be used to document that the proposed stormwater management system (a) complies with Standards 2, 3 and the pretreatment and structural BMP requirements of Standards 4-6 to the maximum extent practicable and (b) improves existing conditions.

Standard 8: Construction Period Pollution Prevention and Erosion and Sedimentation Control

A Construction Period Pollution Prevention and Erosion and Sedimentation Control Plan must include the following information:

- Narrative;
 - Construction Period Operation and Maintenance Plan;
 - Names of Persons or Entity Responsible for Plan Compliance;
 - Construction Period Pollution Prevention Measures;
 - Erosion and Sedimentation Control Plan Drawings;
 - Detail drawings and specifications for erosion control BMPs, including sizing calculations;
 - Vegetation Planning;
 - Site Development Plan;
 - Construction Sequencing Plan;
 - Sequencing of Erosion and Sedimentation Controls;
 - Operation and Maintenance of Erosion and Sedimentation Controls;
 - Inspection Schedule;
 - Maintenance Schedule;
 - Inspection and Maintenance Log Form.
- A Construction Period Pollution Prevention and Erosion and Sedimentation Control Plan containing the information set forth above has been included in the Stormwater Report.

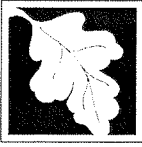

Checklist for Stormwater Report

Checklist (continued)

Standard 8: Construction Period Pollution Prevention and Erosion and Sedimentation Control (continued)

- The project is highly complex and information is included in the Stormwater Report that explains why it is not possible to submit the Construction Period Pollution Prevention and Erosion and Sedimentation Control Plan with the application. A Construction Period Pollution Prevention and Erosion and Sedimentation Control has **not** been included in the Stormwater Report but will be submitted **before** land disturbance begins.
- The project is **not** covered by a NPDES Construction General Permit.
- The project is covered by a NPDES Construction General Permit and a copy of the SWPPP is in the Stormwater Report.
- The project is covered by a NPDES Construction General Permit but no SWPPP been submitted. The SWPPP will be submitted BEFORE land disturbance begins.

Standard 9: Operation and Maintenance Plan

- The Post Construction Operation and Maintenance Plan is included in the Stormwater Report and includes the following information:
 - Name of the stormwater management system owners;
 - Party responsible for operation and maintenance;
 - Schedule for implementation of routine and non-routine maintenance tasks;
 - Plan showing the location of all stormwater BMPs maintenance access areas;
 - Description and delineation of public safety features;
 - Estimated operation and maintenance budget; and
 - Operation and Maintenance Log Form.
- The responsible party is **not** the owner of the parcel where the BMP is located and the Stormwater Report includes the following submissions:
 - A copy of the legal instrument (deed, homeowner's association, utility trust or other legal entity) that establishes the terms of and legal responsibility for the operation and maintenance of the project site stormwater BMPs;
 - A plan and easement deed that allows site access for the legal entity to operate and maintain BMP functions.

Standard 10: Prohibition of Illicit Discharges

- The Long-Term Pollution Prevention Plan includes measures to prevent illicit discharges;
- An Illicit Discharge Compliance Statement is attached;
- NO Illicit Discharge Compliance Statement is attached but will be submitted **prior to** the discharge of any stormwater to post-construction BMPs.

MPA STA 1502
 PK ASPH (SET)
 N: 285559.14
 E: 783950.44
 EL: 112.14

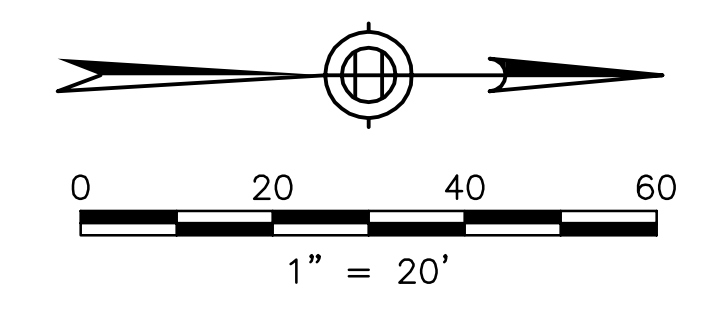

NOTES:

- COORDINATES SHOWN HEREON REFER TO THE NORTH AMERICAN DATUM OF 1983 (NAD83, US SURVEY FEET) MASSACHUSETTS MAINLAND ZONE AND ARE BASED ON THE SURVEY CONTROL NETWORK ESTABLISHED FOR LOGAN AIRPORT BY CHAS. A. SELLS INC. AND PUBLISHED IN DECEMBER 2002.
- ELEVATIONS SHOWN HEREON REFER TO THE NATIONAL GEODETIC VERTICAL DATUM OF 1929 (NGVD29 MEAN SEA LEVEL DATUM).
- UNDERGROUND UTILITIES ARE SHOWN BY MATCHING FIELD LOCATIONS OF EXISTING CASTINGS WITH RECORD PLANS. THE LOCATION OF THESE UTILITIES MAY NOT BE ACCURATE OR COMPLETE. USERS OF THIS PLAN MUST VERIFY UNDERGROUND UTILITY DATA AND TAKE THE NECESSARY STEPS TO ENSURE THE SAFETY OF PERSONNEL AND AVOID INTERRUPTION OF UTILITY SERVICE TO LOGAN AIRPORT.
- IF NECESSARY DURING MOBILIZATION, MASSPORT SURVEY WILL ASSIST THE CONTRACTOR WITH RECOVERY OF PROJECT SURVEY CONTROL POINTS. CALL (617) XXX-XXXX.
- SURVEY CONTROL POINTS DESTROYED OR DISTURBED DURING CONSTRUCTION SHALL BE REPLACED BY THE CONTRACTOR AT NO ADDITIONAL COST. FINAL LOCATIONS OF SURVEY CONTROL SHALL BE APPROVED BY MPA SURVEY.



MASSACHUSETTS PORT AUTHORITY
 EAST BOSTON, MASSACHUSETTS 02128

PROJECT LOCATION:
TAXI POOL & TNC RELOCATION
 LOGAN INTERNATIONAL AIRPORT
 EAST BOSTON, MASSACHUSETTS

MPA CONTRACT NO.: **L1545-C5** LOCATION CODE:
 PROJECT SUBMISSION PHASE: **NOI**

REGISTRATION STAMP:

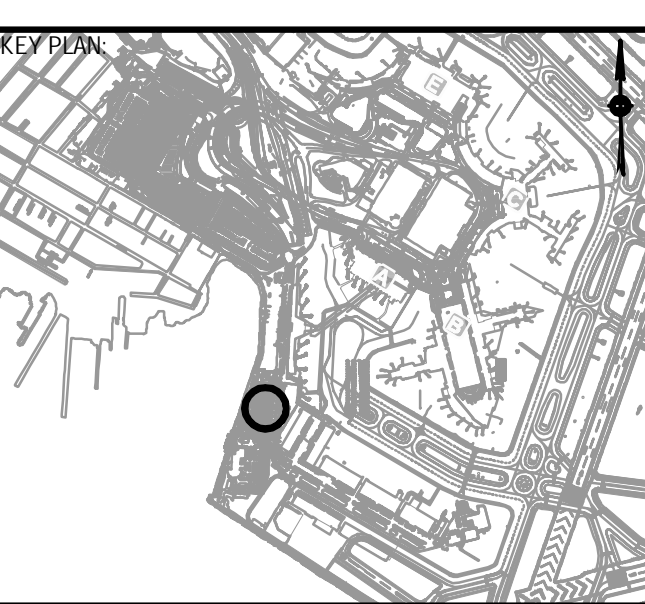

REVISIONS:

REV NO.	DATE	DESCRIPTION	BY

PRIMARY:
WSP
 75 ARLINGTON STREET
 BOSTON, MA 02116
 617.427.7330
 WWW.WSP.COM

PROJECT NUMBER AND TITLE:
L1545-C5
 TAXI POOL

SHEET TITLE:
TAXI HOLDING AREA
 EXISTING CONDITIONS

FOR PERMITTING

DISCIPLINE: **CIVIL**

DRAWN BY:	CHECKED BY:	APPROVED BY:
SDB	KMM	CHB

SCALE: **AS NOTED** DATE: **2018-APR-4**

SHEET NUMBER:
NOI1

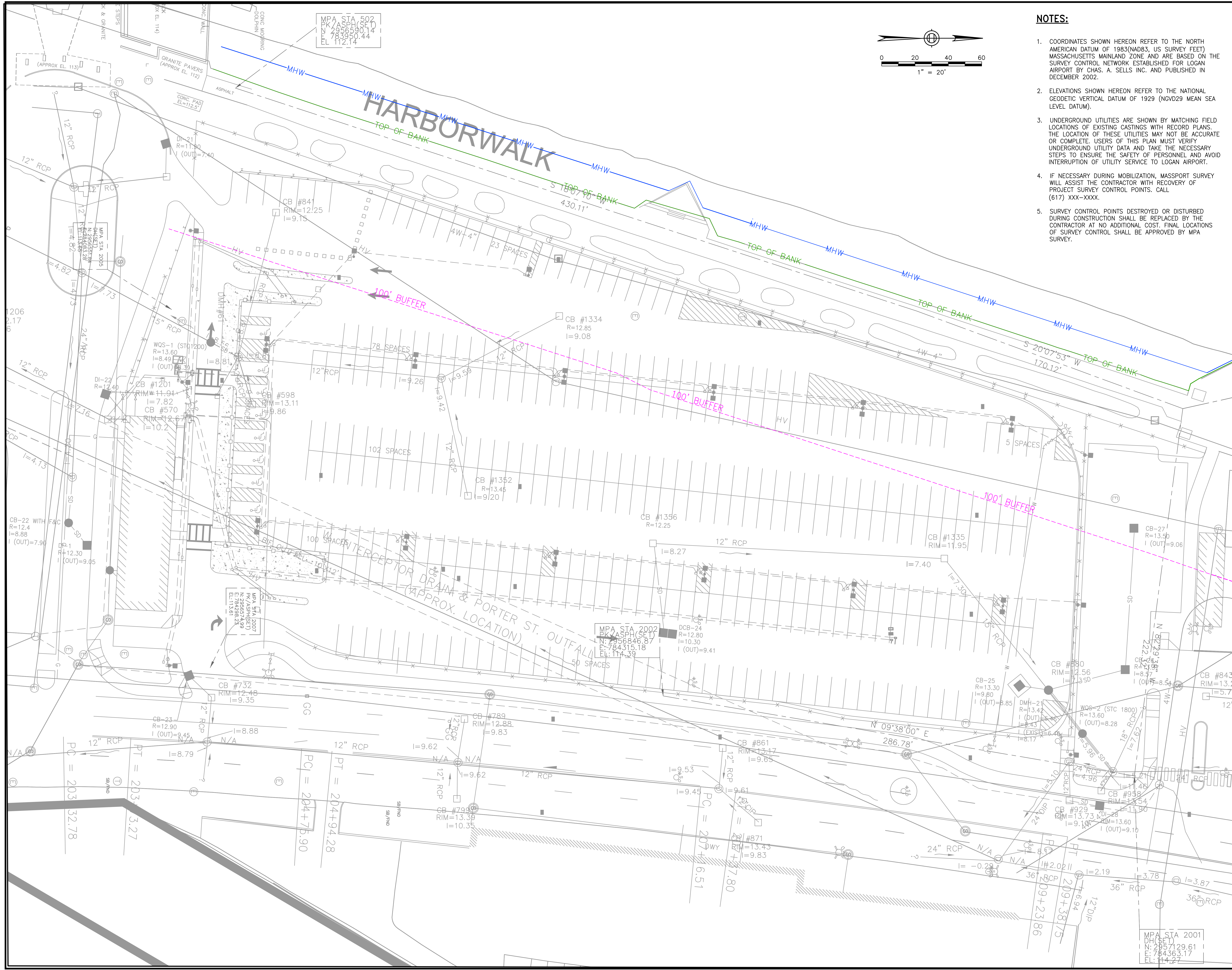

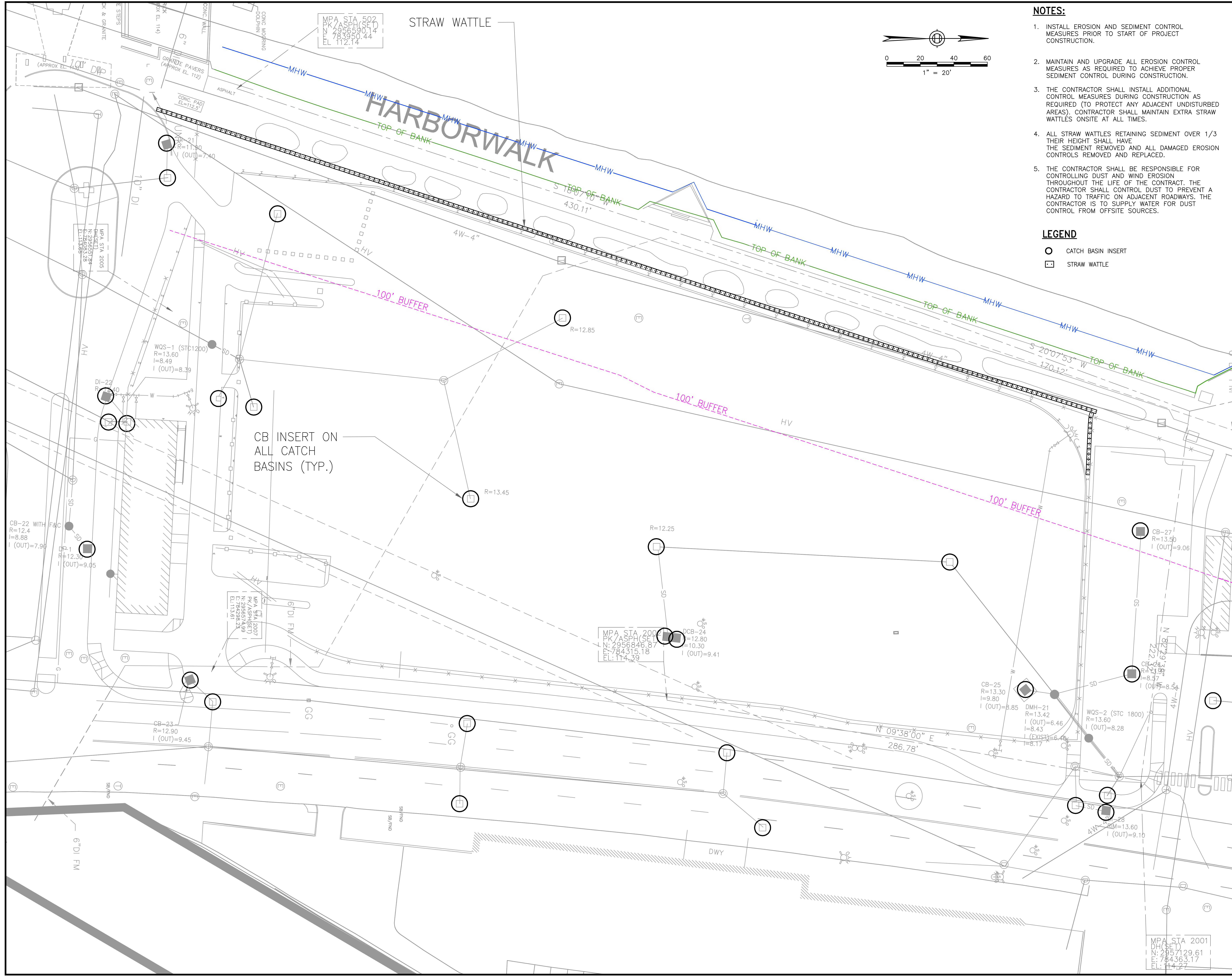

MPA STA 185.02
PK/ASPH (SE)
N: 2839550.14
E: 784315.18
EL: 112.14

MPA STA 2005
PK/ASPH (SE)
N: 29263738
E: 784315.18
EL: 112.14

MPA STA 2007
PK/ASPH (SE)
N: 29263738
E: 784315.18
EL: 113.61

MPA STA 2008
PK/ASPH (SE)
N: 2956846.87
E: 784315.18
EL: 114.39

MPA STA 2001
DH (SE)
N: 2857129.61
E: 784363.17
EL: 114.27

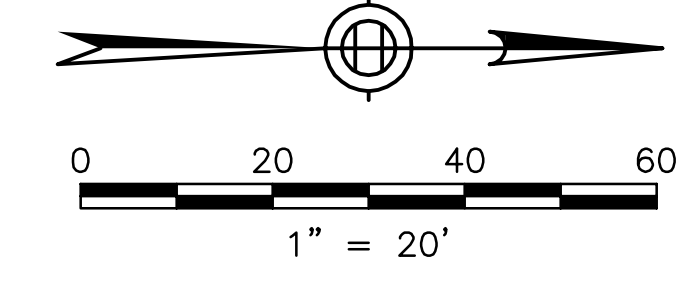

- NOTES:**
1. INSTALL EROSION AND SEDIMENT CONTROL MEASURES PRIOR TO START OF PROJECT CONSTRUCTION.
 2. MAINTAIN AND UPGRADE ALL EROSION CONTROL MEASURES AS REQUIRED TO ACHIEVE PROPER SEDIMENT CONTROL DURING CONSTRUCTION.
 3. THE CONTRACTOR SHALL INSTALL ADDITIONAL CONTROL MEASURES DURING CONSTRUCTION AS REQUIRED (TO PROTECT ANY ADJACENT UNDISTURBED AREAS). CONTRACTOR SHALL MAINTAIN EXTRA STRAW WATTLES ONSITE AT ALL TIMES.
 4. ALL STRAW WATTLES RETAINING SEDIMENT OVER 1/3 THEIR HEIGHT SHALL HAVE THE SEDIMENT REMOVED AND ALL DAMAGED EROSION CONTROLS REMOVED AND REPLACED.
 5. THE CONTRACTOR SHALL BE RESPONSIBLE FOR CONTROLLING DUST AND WIND EROSION THROUGHOUT THE LIFE OF THE CONTRACT. THE CONTRACTOR SHALL CONTROL DUST TO PREVENT A HAZARD TO TRAFFIC ON ADJACENT ROADWAYS. THE CONTRACTOR IS TO SUPPLY WATER FOR DUST CONTROL FROM OFFSITE SOURCES.

- LEGEND**
- CATCH BASIN INSERT
 - ▣ STRAW WATTLE

MASSACHUSETTS PORT AUTHORITY
EAST BOSTON, MASSACHUSETTS 02128

PROJECT LOCATION:
TAXI POOL & TNC RELOCATION
LOGAN INTERNATIONAL AIRPORT
EAST BOSTON, MASSACHUSETTS

MPA CONTRACT NO.: L1545-C5 LOCATION CODE: NO1

PROJECT SUBMISSION PHASE: NO1

REGISTRATION STAMP:
KATHRYN M. MACKAY
CIVIL
NO. 47168
Boston

KEY PLAN:

REV NO	DATE	DESCRIPTION	BY

PRIMARY:

75 ARLINGTON STREET
BOSTON, MA 02116
617.427.7330
WWW.WSP.COM

PROJECT NUMBER AND TITLE:
L1545-C5
TAXI POOL

SHEET TITLE:
TAXI HOLDING AREA
SEDIMENTATION & EROSION
CONTROL PLAN
FOR PERMITTING

DISCIPLINE:
CIVIL

DRAWN BY:	CHECKED BY:	APPROVED BY:
SDB	KMM	CHB

SCALE: AS NOTED DATE: 2018-APR-4

SHEET NUMBER:
NO12

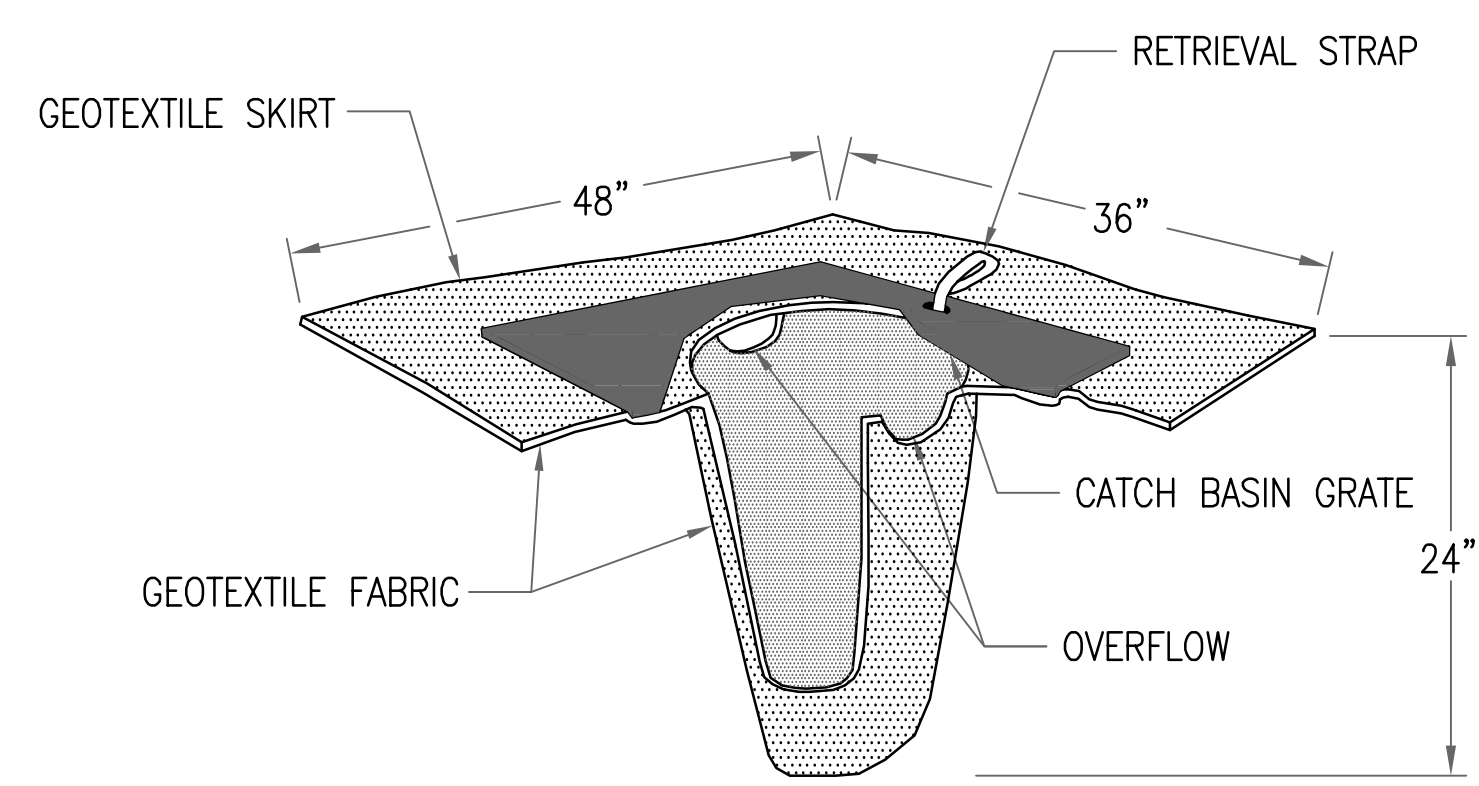

**CATCH BASIN INSERT
FOR SEDIMENT CONTROL**
NOT TO SCALE

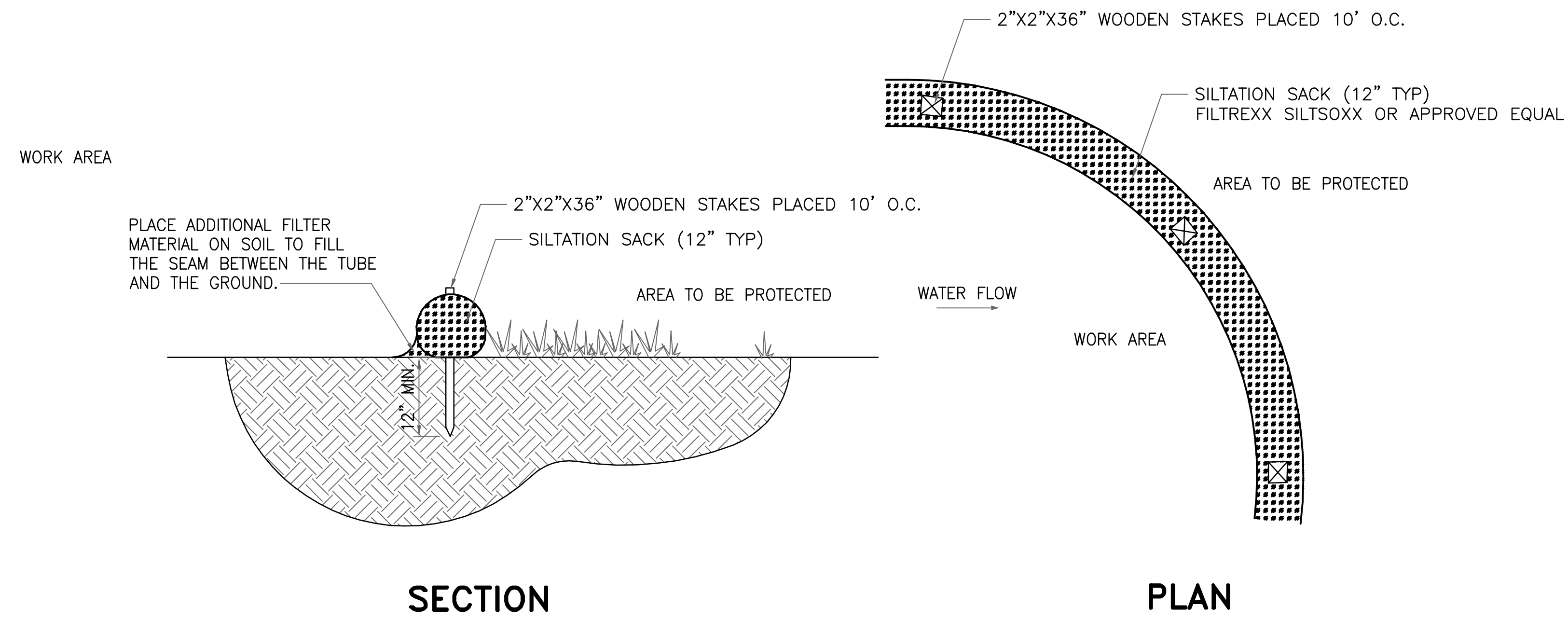

SILTATION SACK FOR SEDIMENT CONTROL
NOT TO SCALE

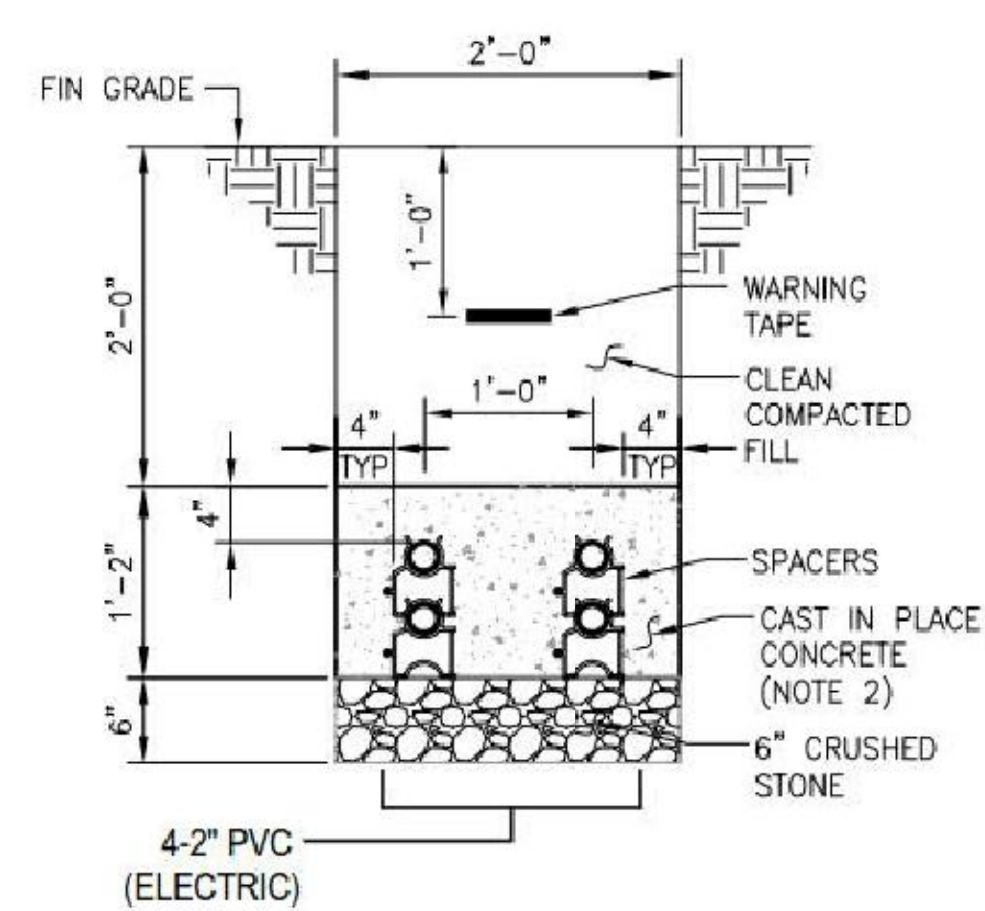

A-A DUCTBANK
TYP-E03 NO SCALE

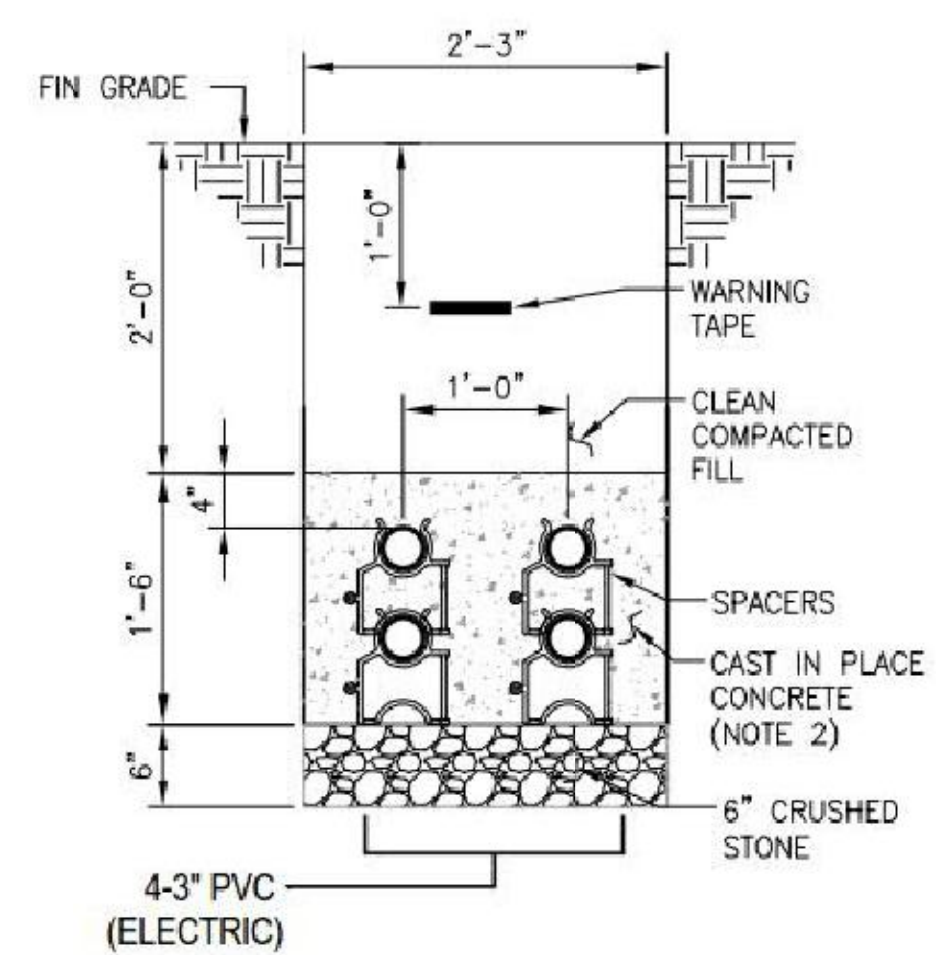

F-F DUCTBANK
TYP-E03 NO SCALE

EV DUCTBANKS
NOT TO SCALE

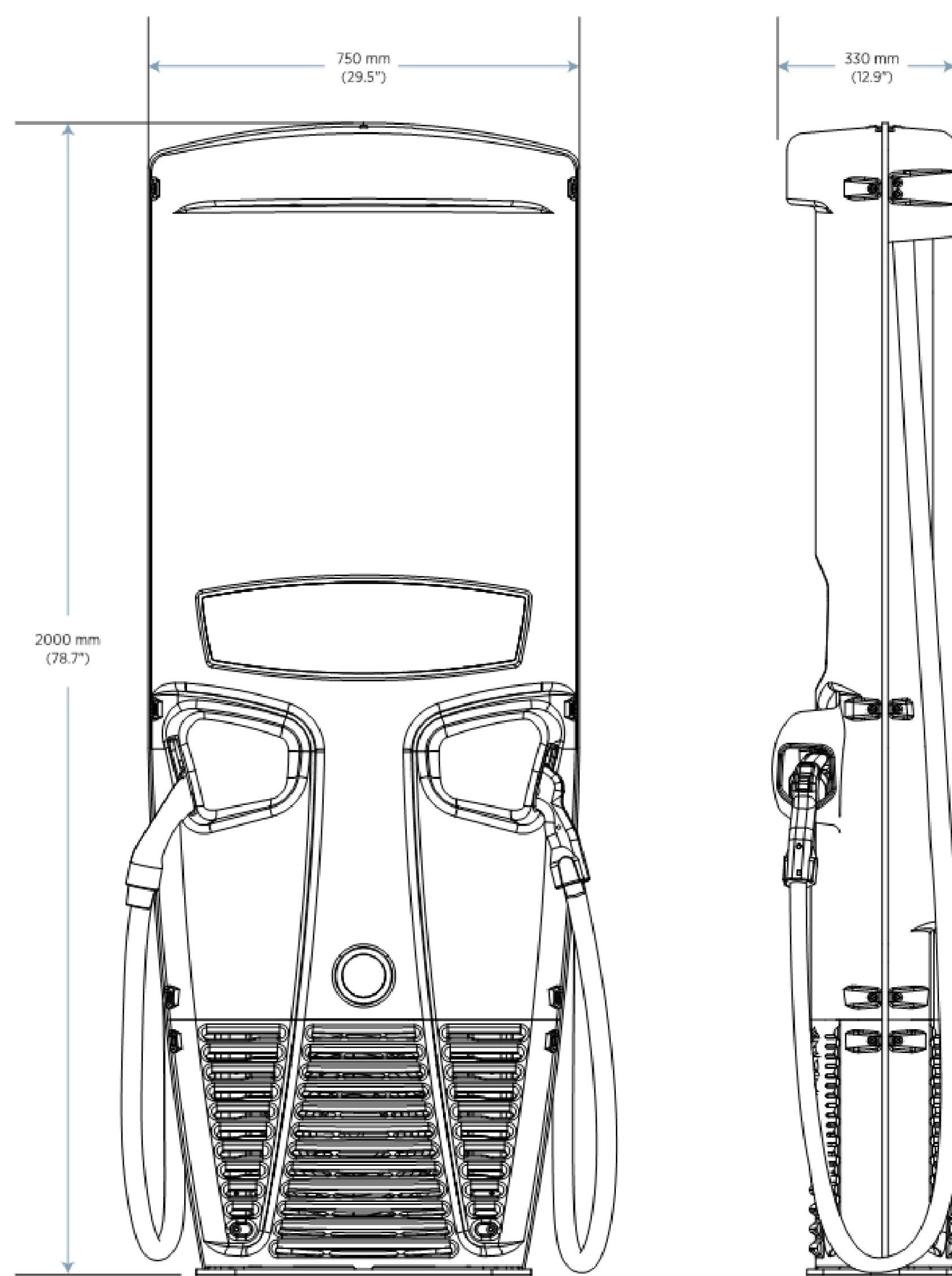

EV CHARGING STATION
NOT TO SCALE



MASSACHUSETTS PORT AUTHORITY
EAST BOSTON, MASSACHUSETTS 02128

PROJECT LOCATION:
TAXI POOL & TNC RELOCATION
LOGAN INTERNATIONAL AIRPORT
EAST BOSTON, MASSACHUSETTS

MPA CONTRACT NO.: L1545-C5 LOCATION CODE:
PROJECT SUBMISSION PHASE: NOI

REGISTRATION STAMP:

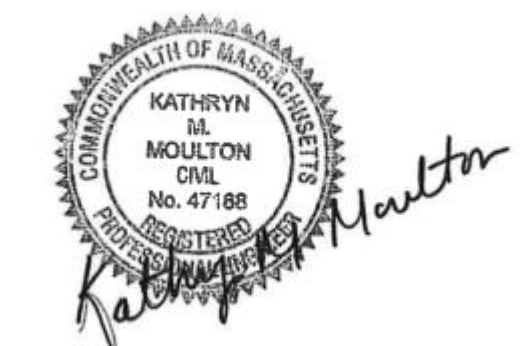

KEY PLAN:

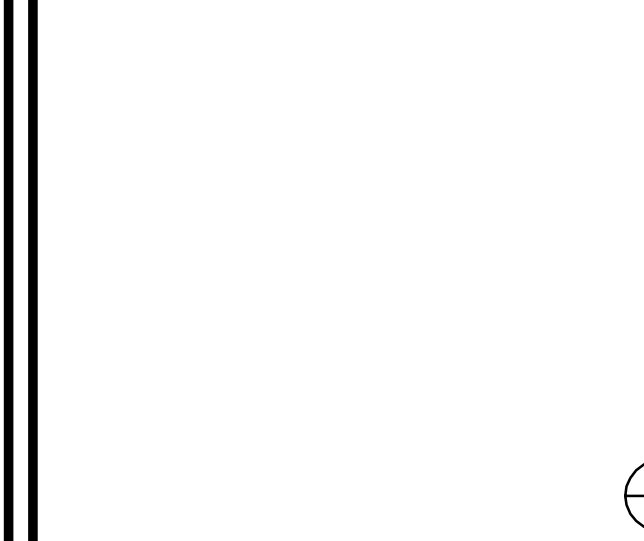

REVISIONS:

REV NO.	DATE	DESCRIPTION	BY

PRIMARY:

wsp
75 ARLINGTON STREET
BOSTON, MA 02116
617.427.7330
WWW.WSP.COM

PROJECT NUMBER AND TITLE:

L1545-C5
TAXI POOL

SHEET TITLE:

TAXI HOLDING AREA
SEDIMENT & EROSION
CONTROL PLAN DETAILS
FOR PERMITTING

DISCIPLINE:

CIVIL

DRAWN BY: CHECKED BY: APPROVED BY:

SDB KMM CHB

SCALE: DATE:

AS NOTED 2018-APR-4

SHEET NUMBER:

NOI3

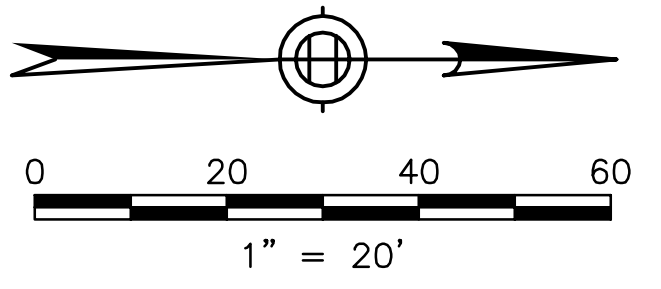
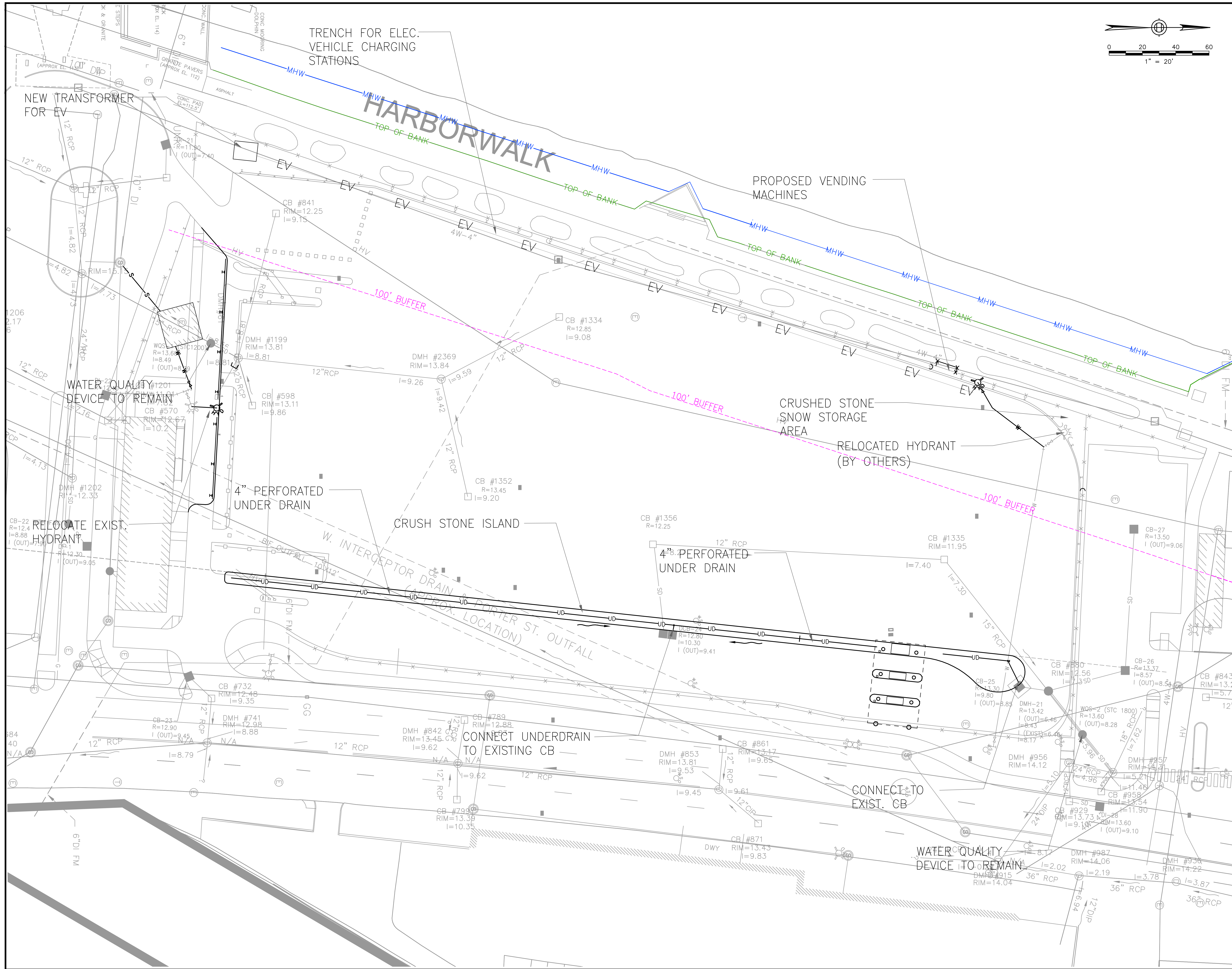

MASSACHUSETTS PORT AUTHORITY
EAST BOSTON, MASSACHUSETTS 02128

PROJECT LOCATION:
TAXI POOL & TNC RELOCATION
LOGAN INTERNATIONAL AIRPORT
EAST BOSTON, MASSACHUSETTS

MPA CONTRACT NO:
L1545-C5

LOCATION CODE:
NOI

PROJECT SUBMISSION PHASE:
NOI

REGISTRATION STAMP:

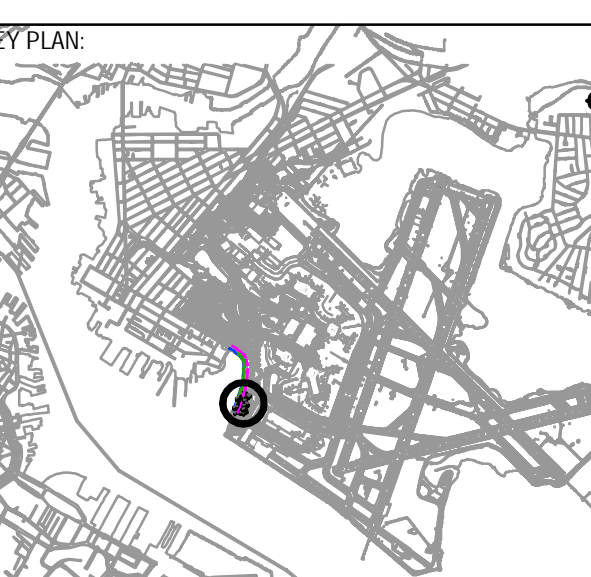

REVISIONS:

REV NO	DATE	DESCRIPTION	BY

PRIMARY:

wsp

75 ARLINGTON STREET
BOSTON, MA 02116
617.427.7330
WWW.WSP.COM

PROJECT NUMBER AND TITLE:

L1545-C5
TAXI POOL

SHEET TITLE:
**TAXI HOLDING AREA
GRADING & UTILITY
PLAN
FOR PERMITTING**

DISCIPLINE: CIVIL

DRAWN BY: SDB	CHECKED BY: KMM	APPROVED BY: CHB
------------------	--------------------	---------------------

SCALE: AS NOTED DATE: 2018-APR-4

SHEET NUMBER:

NOI4